

SECTION **IP**  
INSTRUMENT PANEL

A  
B  
C  
D  
E  
F  
G  
H  
I  
IP  
K  
L  
M  
N  
O  
P

CONTENTS

<b>PRECAUTION</b> .....	2	Removal and Installation .....	15
<b>PRECAUTIONS</b> .....	2	<b>STEERING COLUMN COVERS</b> .....	18
Precaution for Supplemental Restraint System (SRS) "AIR BAG" and "SEAT BELT PRE-TENSIONER" .....	2	Removal and Installation .....	18
Precaution for Work .....	2	<b>CLUSTER LID A</b> .....	19
<b>PREPARATION</b> .....	3	Removal and Installation .....	19
<b>PREPARATION</b> .....	3	<b>INSTRUMENT LOWER PANEL LH</b> .....	20
Special Service Tools .....	3	Removal and Installation .....	20
Commercial Service Tools .....	3	<b>CLUSTER LID C</b> .....	21
<b>CLIP LIST</b> .....	4	Removal and Installation .....	21
Descriptions for Clips .....	4	<b>GLOVE BOX ASSEMBLY AND HOUSING</b> .....	22
<b>SYMPTOM DIAGNOSIS</b> .....	8	Removal and Installation .....	22
<b>SQUEAK AND RATTLE TROUBLE DIAGNOSES</b> .....	8	<b>CENTER CONSOLE ASSEMBLY</b> .....	23
Work Flow .....	8	Exploded View .....	23
Generic Squeak and Rattle Troubleshooting .....	10	Removal and Installation .....	23
Diagnostic Worksheet .....	12	<b>CENTER CONSOLE LOWER</b> .....	25
<b>REMOVAL AND INSTALLATION</b> .....	14	Removal and Installation .....	25
<b>INSTRUMENT PANEL ASSEMBLY</b> .....	14	<b>UNIT DISASSEMBLY AND ASSEMBLY</b> ...	26
Exploded View .....	14	<b>CENTER CONSOLE ASSEMBLY</b> .....	26
		Exploded View .....	26
		Disassembly and Assembly .....	26

# PRECAUTIONS

< PRECAUTION >

## PRECAUTION

### PRECAUTIONS

#### Precaution for Supplemental Restraint System (SRS) "AIR BAG" and "SEAT BELT PRE-TENSIONER"

INFOID:000000009266842

The Supplemental Restraint System such as "AIR BAG" and "SEAT BELT PRE-TENSIONER", used along with a front seat belt, helps to reduce the risk or severity of injury to the driver and front passenger for certain types of collision. This system includes seat belt switch inputs and dual stage front air bag modules. The SRS system uses the seat belt switches to determine the front air bag deployment, and may only deploy one front air bag, depending on the severity of a collision and whether the front occupants are belted or unbelted. Information necessary to service the system safely is included in the SR and SB section of this Service Manual.

#### **WARNING:**

- To avoid rendering the SRS inoperative, which could increase the risk of personal injury or death in the event of a collision which would result in air bag inflation, all maintenance must be performed by an authorized NISSAN/INFINITI dealer.
- Improper maintenance, including incorrect removal and installation of the SRS, can lead to personal injury caused by unintentional activation of the system. For removal of Spiral Cable and Air Bag Module, see the SR section.
- Do not use electrical test equipment on any circuit related to the SRS unless instructed to in this Service Manual. SRS wiring harnesses can be identified by yellow and/or orange harnesses or harness connectors.

#### PRECAUTIONS WHEN USING POWER TOOLS (AIR OR ELECTRIC) AND HAMMERS

#### **WARNING:**

- When working near the Airbag Diagnosis Sensor Unit or other Airbag System sensors with the Ignition ON or engine running, DO NOT use air or electric power tools or strike near the sensor(s) with a hammer. Heavy vibration could activate the sensor(s) and deploy the air bag(s), possibly causing serious injury.
- When using air or electric power tools or hammers, always switch the Ignition OFF, disconnect the battery, and wait at least 3 minutes before performing any service.

#### Precaution for Work

INFOID:000000009266843

- When removing or disassembling each component, be careful not to damage or deform it. If a component may be subject to interference, be sure to protect it with a shop cloth.
- When removing (disengaging) components with a screwdriver or similar tool, be sure to wrap the component with a shop cloth or vinyl tape to protect it.
- Protect the removed parts with a shop cloth and prevent them from being dropped.
- Replace a deformed or damaged clip.
- If a part is specified as a non-reusable part, always replace it with a new one.
- Be sure to tighten bolts and nuts securely to the specified torque.
- After installation is complete, be sure to check that each part works properly.
- Follow the steps below to clean components:
  - Water soluble dirt:
    - Dip a soft cloth into lukewarm water, wring the water out of the cloth and wipe the dirty area.
    - Then rub with a soft, dry cloth.
  - Oily dirt:
    - Dip a soft cloth into lukewarm water with mild detergent (concentration: within 2 to 3%) and wipe the dirty area.
    - Then dip a cloth into fresh water, wring the water out of the cloth and wipe the detergent off.
    - Then rub with a soft, dry cloth.
  - Do not use organic solvent such as thinner, benzene, alcohol or gasoline.
  - For genuine leather seats, use a genuine leather seat cleaner.

# PREPARATION

< PREPARATION >

## PREPARATION

### PREPARATION

#### Special Service Tools

INFOID:000000009266844

The actual shapes of Kent-Moore tools may differ from those of special service tools illustrated here.

Tool number (Kent-Moore No.) Tool name	Description
— (J-39570) Chassis Ear	Locating the noise
— (J-43980) NISSAN Squeak and Rattle Kit	Repairing the cause of noise
— (J-46534) Trim Tool Set	Removing trim components

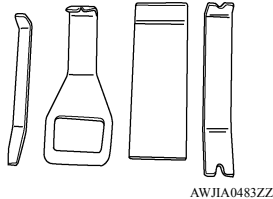
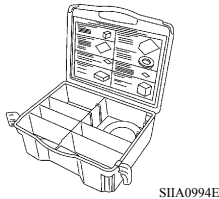
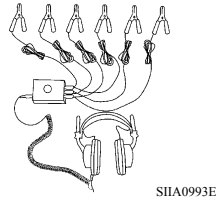

#### Commercial Service Tools

INFOID:000000009266845

(Kent-Moore No.) Tool name	Description
(J-39565) Engine Ear	Locating the noise
( — ) Power tool	Loosening nuts, screws and bolts

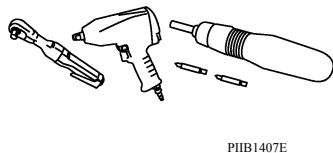
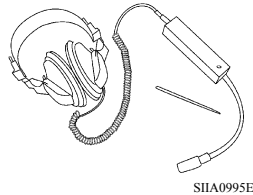

# CLIP LIST







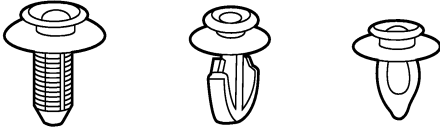

< PREPARATION >

## CLIP LIST

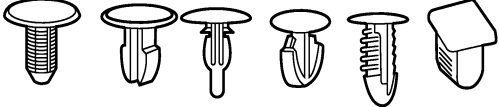
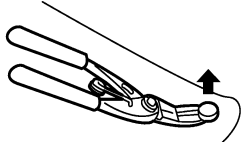
Descriptions for Clips

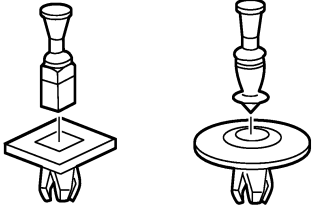
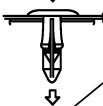
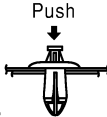
INFOID:000000009266846

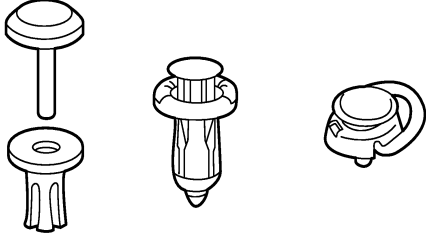
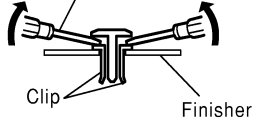

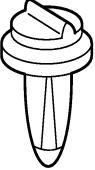
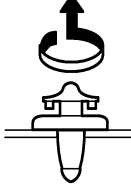





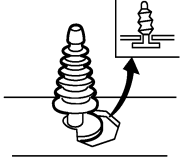
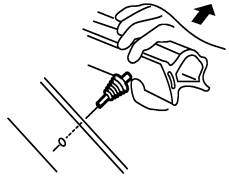

Replace any clips which are damaged during removal or installation.

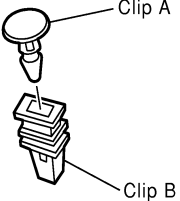
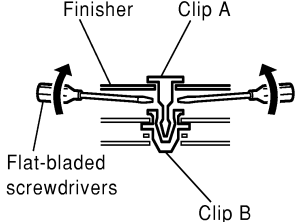
Symbol No.	Shapes	Removal & Installation
<p>C101</p> 		<p><b>Removal:</b> Remove by bending up with flat-bladed screwdrivers or clip remover.</p> 
<p>C103</p> 		 <p><b>Removal:</b> Remove with a clip remover.</p>
<p>C203</p> 		<p><b>Removal:</b> Push center pin to catching position. (Do not remove center pin by hitting it.)</p> <p>Push</p>  <p><b>Installation:</b></p> 
<p>C205</p> 		<p><b>Removal:</b></p> 
<p>C206</p> 		<p><b>Removal:</b></p> 

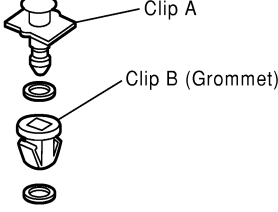
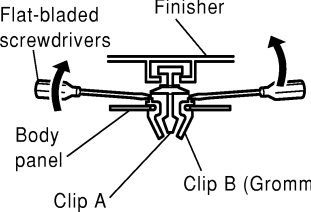
SIIA0315E

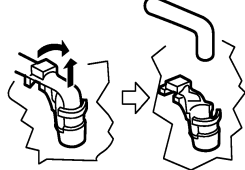
# CLIP LIST

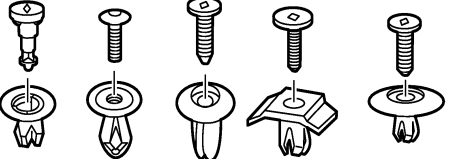
## < PREPARATION >









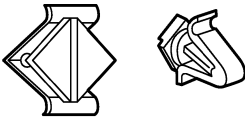

Symbol No.	Shapes	Removal & Installation
<p>CE103</p> 		<p><b>Removal:</b></p> 
<p>CF110</p> 		<p><b>Removal:</b></p> 
<p>CF118</p> 		<p><b>Removal:</b></p> 
<p>CR103</p> 		<p><b>Removal:</b> Holder portion of clip must be spread out to remove rod.</p> 
<p>CS101</p> 		<p><b>Removal:</b></p> <ol style="list-style-type: none"> <li>1. Screw out with a Phillips screwdriver.</li> <li>2. Remove female portion with flat-bladed screwdriver.</li> </ol> 

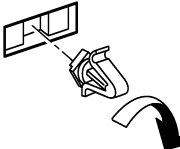
S1IA0316E

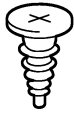
A  
B  
C  
D  
E  
F  
G  
H  
I  
IP  
K  
L  
M  
N  
O  
P

# CLIP LIST

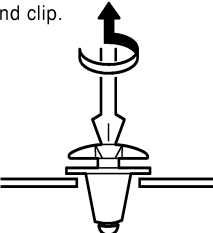

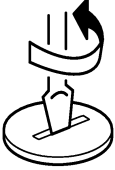
## < PREPARATION >

Symbol No.	Shapes	Removal & Installation	
CG101 		<b>Removal:</b>  Rotate 45° to remove	<b>Installation:</b> 
CS102 			
CS113 		<b>Removal:</b> Disconnect upper connection of clip with a flat-bladed screwdriver, then remove clip while inserting a flat-bladed screwdriver between body panel and clip. 	
C111 			

SIA0317E

# CLIP LIST

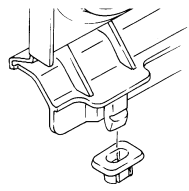
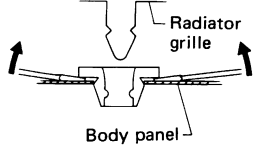
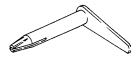
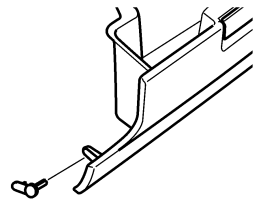
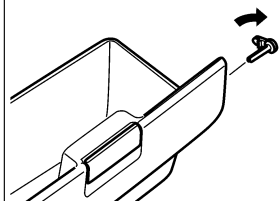
< PREPARATION >

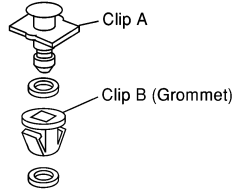
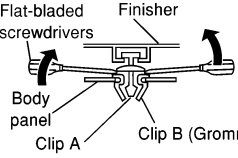
Symbol No.	Shapes	Removal & Installation
<p>CG104</p> 		<p><b>Removal:</b> Remove by bending up with flat-bladed screwdrivers.</p> 
<p>CE114</p> 		
<p>CF118</p> 		<p><b>Removal:</b> Flat-bladed screwdrivers</p> 

ALJIA0564GB

A  
B  
C  
D  
E  
F  
G  
H  
I  
IP  
K  
L  
M  
N  
O  
P

# SQUEAK AND RATTLE TROUBLE DIAGNOSES

< SYMPTOM DIAGNOSIS >

## SYMPTOM DIAGNOSIS

### SQUEAK AND RATTLE TROUBLE DIAGNOSES

#### Work Flow

INFOID:000000009266847

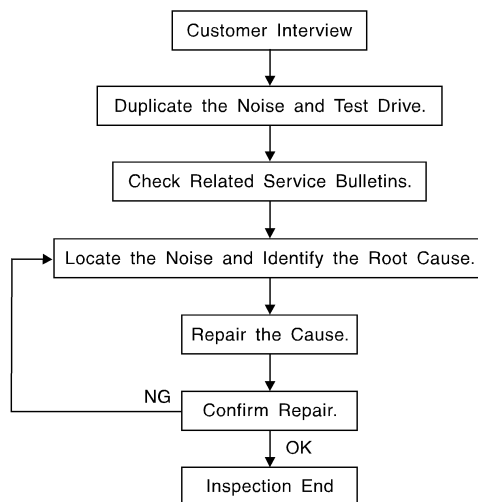

SBT842

#### CUSTOMER INTERVIEW

Interview the customer if possible, to determine the conditions that exist when the noise occurs. Use the Diagnostic Worksheet during the interview to document the facts and conditions when the noise occurs and any customer's comments; refer to [IP-12, "Diagnostic Worksheet"](#). This information is necessary to duplicate the conditions that exist when the noise occurs.

- The customer may not be able to provide a detailed description or the location of the noise. Attempt to obtain all the facts and conditions that exist when the noise occurs (or does not occur).
- If there is more than one noise in the vehicle, be sure to diagnose and repair the noise that the customer is concerned about. This can be accomplished by test driving the vehicle with the customer.
- After identifying the type of noise, isolate the noise in terms of its characteristics. The noise characteristics are provided so the customer, service adviser and technician are all speaking the same language when defining the noise.
- Squeak —(Like tennis shoes on a clean floor)  
Squeak characteristics include the light contact/fast movement/brought on by road conditions/hard surfaces = higher pitch noise/softer surfaces = lower pitch noises/edge to surface = chirping.
- Creak—(Like walking on an old wooden floor)  
Creak characteristics include firm contact/slow movement/twisting with a rotational movement/pitch dependent on materials/often brought on by activity.
- Rattle—(Like shaking a baby rattle)  
Rattle characteristics include the fast repeated contact/vibration or similar movement/loose parts/missing clip or fastener/incorrect clearance.
- Knock —(Like a knock on a door)  
Knock characteristics include hollow sounding/sometimes repeating/often brought on by driver action.
- Tick—(Like a clock second hand)  
Tick characteristics include gentle contacting of light materials/loose components/can be caused by driver action or road conditions.
- Thump—(Heavy, muffled knock noise)  
Thump characteristics include softer knock/dead sound often brought on by activity.
- Buzz—(Like a bumble bee)  
Buzz characteristics include high frequency rattle/firm contact.
- Often the degree of acceptable noise level will vary depending upon the person. A noise that you may judge as acceptable may be very irritating to the customer.
- Weather conditions, especially humidity and temperature, may have a great effect on noise level.

#### DUPLICATE THE NOISE AND TEST DRIVE



# SQUEAK AND RATTLE TROUBLE DIAGNOSES

## < SYMPTOM DIAGNOSIS >

If possible, drive the vehicle with the customer until the noise is duplicated. Note any additional information on the Diagnostic Worksheet regarding the conditions or location of the noise. This information can be used to duplicate the same conditions when you confirm the repair.

If the noise can be duplicated easily during the test drive, to help identify the source of the noise, try to duplicate the noise with the vehicle stopped by doing one or all of the following:

- 1) Close a door.
  - 2) Tap or push/pull around the area where the noise appears to be coming from.
  - 3) Rev the engine.
  - 4) Use a floor jack to recreate vehicle "twist".
  - 5) At idle, apply engine load (electrical load, half-clutch on M/T model, drive position on CVT and A/T models).
  - 6) Raise the vehicle on a hoist and hit a tire with a rubber hammer.
- Drive the vehicle and attempt to duplicate the conditions the customer states exist when the noise occurs.
  - If it is difficult to duplicate the noise, drive the vehicle slowly on an undulating or rough road to stress the vehicle body.

## CHECK RELATED SERVICE BULLETINS

After verifying the customer concern or symptom, check ASIST for Technical Service Bulletins (TSBs) related to that concern or symptom.

If a TSB relates to the symptom, follow the procedure to repair the noise.

## LOCATE THE NOISE AND IDENTIFY THE ROOT CAUSE

1. Narrow down the noise to a general area. To help pinpoint the source of the noise, use a listening tool (Chassis Ear: J-39570, Engine Ear: J-39565 and mechanic's stethoscope).
2. Narrow down the noise to a more specific area and identify the cause of the noise by:
  - removing the components in the area that you suspect the noise is coming from.  
Do not use too much force when removing clips and fasteners, otherwise clips and fasteners can be broken or lost during the repair, resulting in the creation of new noise.
  - tapping or pushing/pulling the component that you suspect is causing the noise.  
Do not tap or push/pull the component with excessive force, otherwise the noise will be eliminated only temporarily.
  - feeling for a vibration with your hand by touching the component(s) that you suspect is (are) causing the noise.
  - placing a piece of paper between components that you suspect are causing the noise.
  - looking for loose components and contact marks.Refer to [IP-10, "Generic Squeak and Rattle Troubleshooting"](#).

## REPAIR THE CAUSE

- If the cause is a loose component, tighten the component securely.
- If the cause is insufficient clearance between components:
  - separate components by repositioning or loosening and retightening the component, if possible.
  - insulate components with a suitable insulator such as urethane pads, foam blocks, felt cloth tape or urethane tape. A NISSAN Squeak and Rattle Kit (J-43980) is available through your authorized NISSAN Parts Department.

### **CAUTION:**

**Do not use excessive force as many components are constructed of plastic and may be damaged.**

**Always check with the Parts Department for the latest parts information.**

**The following materials are contained in the NISSAN Squeak and Rattle Kit (J-43980). Each item can be ordered separately as needed.**

### **URETHANE PADS [1.5 mm (0.059 in) thick]**

**Insulates connectors, harness, etc.**

**76268-9E005: 100×135 mm (3.94×5.31 in)/76884-71L01: 60×85 mm (2.36×3.35 in)/76884-71L02: 15×25 mm (0.59×0.98 in)**

### **INSULATOR (Foam blocks)**

**Insulates components from contact. Can be used to fill space behind a panel.**

**73982-9E000: 45 mm (1.77 in) thick, 50×50 mm (1.97×1.97 in)/73982-50Y00: 10 mm (0.39 in) thick, 50×50 mm (1.97×1.97 in)**

### **INSULATOR (Light foam block)**

**80845-71L00: 30 mm (1.18 in) thick, 30×50 mm (1.18×1.97 in)**

### **FELT CLOTH TAPE**

**Used to insulate where movement does not occur. Ideal for instrument panel applications.**

**68370-4B000: 15×25 mm (0.59×0.98 in) pad/68239-13E00: 5 mm (0.20 in) wide tape roll. The following materials not found in the kit can also be used to repair squeaks and rattles.**

# SQUEAK AND RATTLE TROUBLE DIAGNOSES

## < SYMPTOM DIAGNOSIS >

---

### UHMW (TEFLON) TAPE

Insulates where slight movement is present. Ideal for instrument panel applications.

### SILICONE GREASE

Used instead of UHMW tape that will be visible or not fit.

Note: Will only last a few months.

### SILICONE SPRAY

Use when grease cannot be applied.

### DUCT TAPE

Use to eliminate movement.

### CONFIRM THE REPAIR

Confirm that the cause of a noise is repaired by test driving the vehicle. Operate the vehicle under the same conditions as when the noise originally occurred. Refer to the notes on the Diagnostic Worksheet.

## Generic Squeak and Rattle Troubleshooting

INFOID:000000009266848

Refer to Table of Contents for specific component removal and installation information.

### INSTRUMENT PANEL

Most incidents are caused by contact and movement between:

1. Cluster lid A and the instrument panel
2. Acrylic lens and combination meter housing
3. Instrument panel to front pillar finisher
4. Instrument panel to windshield
5. Instrument panel pins
6. Wiring harnesses behind the combination meter
7. A/C defroster duct and duct joint

These incidents can usually be located by tapping or moving the components to duplicate the noise or by pressing on the components while driving to stop the noise. Most of these incidents can be repaired by applying felt cloth tape or silicone spray (in hard to reach areas). Urethane pads can be used to insulate wiring harness.

### CAUTION:

**Do not use silicone spray to isolate a squeak or rattle. If you saturate the area with silicone, you will not be able to recheck the repair.**

### CENTER CONSOLE

Components to pay attention to include:

1. Shift selector assembly cover to finisher
2. A/C control unit and cluster lid C
3. Wiring harnesses behind audio and A/C control unit

The instrument panel repair and isolation procedures also apply to the center console.

### DOORS

Pay attention to the:

1. Finisher and inner panel making a slapping noise
2. Inside handle escutcheon to door finisher
3. Wiring harnesses tapping
4. Door striker out of alignment causing a popping noise on starts and stops

Tapping or moving the components or pressing on them while driving to duplicate the conditions can isolate many of these incidents. You can usually insulate the areas with felt cloth tape or insulator foam blocks from the NISSAN Squeak and Rattle Kit (J-43980) to repair the noise.

### TRUNK

Trunk noises are often caused by a loose jack or loose items put into the trunk by the owner.

In addition look for:

1. Trunk lid bumpers out of adjustment
2. Trunk lid striker out of adjustment
3. The trunk lid torsion bars knocking together

# SQUEAK AND RATTLE TROUBLE DIAGNOSES

## < SYMPTOM DIAGNOSIS >

---

### 4. A loose license plate or bracket

Most of these incidents can be repaired by adjusting, securing or insulating the item(s) or component(s) causing the noise.

A

### SUNROOF/HEADLINING

Noises in the sunroof/headlining area can often be traced to one of the following:

B

1. Sunroof lid, rail, linkage or seals making a rattle or light knocking noise
2. Sun visor shaft shaking in the holder
3. Front or rear windshield touching headlining and squeaking

C

Again, pressing on the components to stop the noise while duplicating the conditions can isolate most of these incidents. Repairs usually consist of insulating with felt cloth tape.

D

### OVERHEAD CONSOLE (FRONT AND REAR)

Overhead console noises are often caused by the console panel clips not being engaged correctly. Most of these incidents are repaired by pushing up on the console at the clip locations until the clips engage.

E

In addition look for:

1. Loose harness or harness connectors.
2. Front console map/reading lamp lens loose.
3. Loose screws at console attachment points.

F

### SEATS

When isolating seat noise it's important to note the position the seat is in and the load placed on the seat when the noise is present. These conditions should be duplicated when verifying and isolating the cause of the noise.

G

Cause of seat noise include:

H

1. Headrest rods and holder
2. A squeak between the seat pad cushion and frame
3. The rear seatback lock and bracket

I

These noises can be isolated by moving or pressing on the suspected components while duplicating the conditions under which the noise occurs. Most of these incidents can be repaired by repositioning the component or applying urethane tape to the contact area.

IP

### UNDERHOOD

Some interior noise may be caused by components under the hood or on the engine wall. The noise is then transmitted into the passenger compartment.

K

Causes of transmitted underhood noise include:

1. Any component installed to the engine wall
2. Components that pass through the engine wall
3. Engine wall mounts and connectors
4. Loose radiator installation pins
5. Hood bumpers out of adjustment
6. Hood striker out of adjustment

L

M

These noises can be difficult to isolate since they cannot be reached from the interior of the vehicle. The best method is to secure, move or insulate one component at a time and test drive the vehicle. Also, engine rpm or load can be changed to isolate the noise. Repairs can usually be made by moving, adjusting, securing, or insulating the component causing the noise.

N

O

P

# SQUEAK AND RATTLE TROUBLE DIAGNOSES

< SYMPTOM DIAGNOSIS >

## Diagnostic Worksheet

INFOID:000000009266849

Dear Customer:

We are concerned about your satisfaction with your vehicle. Repairing a squeak or rattle sometimes can be very difficult. To help us fix your vehicle right the first time, please take a moment to note the area of the vehicle where the squeak or rattle occurs and under what conditions. You may be asked to take a test drive with a service advisor or technician to ensure we confirm the noise you are hearing.

### SQUEAK & RATTLE DIAGNOSTIC WORKSHEET

#### I. WHERE DOES THE NOISE COME FROM? (circle the area of the vehicle)

The illustrations are for reference only, and may not reflect the actual configuration of your vehicle.

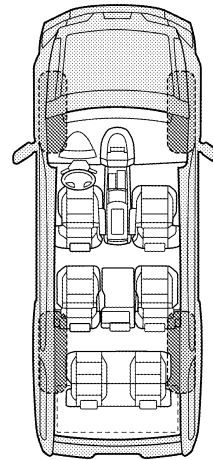
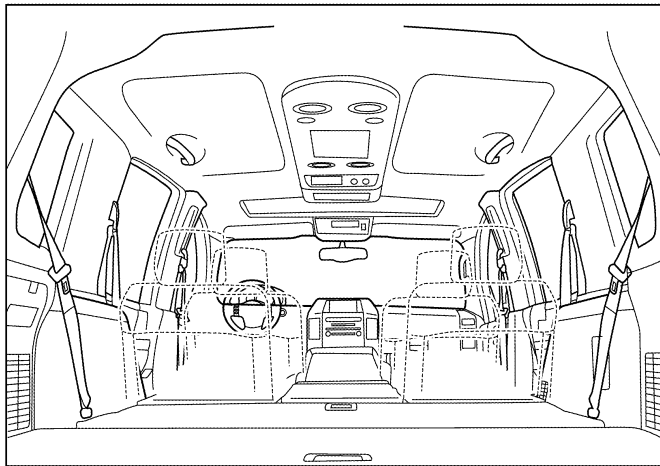
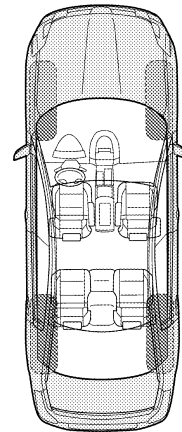
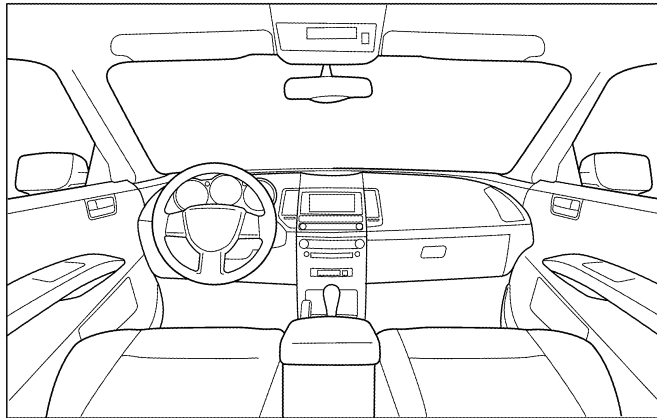

Continue to page 2 of the worksheet and briefly describe the location of the noise or rattle. In addition, please indicate the conditions which are present when the noise occurs.

# SQUEAK AND RATTLE TROUBLE DIAGNOSES

< SYMPTOM DIAGNOSIS >

## SQUEAK & RATTLE DIAGNOSTIC WORKSHEET - page 2

Briefly describe the location where the noise occurs:

\_\_\_\_\_  
\_\_\_\_\_

### II. WHEN DOES IT OCCUR? (please check the boxes that apply)

- |   |  |
|---|--|
| <input type="checkbox"/> Anytime                      | <input type="checkbox"/> After sitting out in the rain |
| <input type="checkbox"/> 1st time in the morning      | <input type="checkbox"/> When it is raining or wet     |
| <input type="checkbox"/> Only when it is cold outside | <input type="checkbox"/> Dry or dusty conditions       |
| <input type="checkbox"/> Only when it is hot outside  | <input type="checkbox"/> Other:                        |

### III. WHEN DRIVING:

- Through driveways
- Over rough roads
- Over speed bumps
- Only about \_\_\_\_ mph
- On acceleration
- Coming to a stop
- On turns: left, right or either (circle)
- With passengers or cargo
- Other: \_\_\_\_\_
- After driving \_\_\_\_ miles or \_\_\_\_ minutes

### IV. WHAT TYPE OF NOISE

- Squeak (like tennis shoes on a clean floor)
- Creak (like walking on an old wooden floor)
- Rattle (like shaking a baby rattle)
- Knock (like a knock at the door)
- Tick (like a clock second hand)
- Thump (heavy muffled knock noise)
- Buzz (like a bumble bee)

### TO BE COMPLETED BY DEALERSHIP PERSONNEL

Test Drive Notes:

\_\_\_\_\_  
\_\_\_\_\_  
\_\_\_\_\_

	YES	NO	Initials of person performing
Vehicle test driven with customer	<input type="checkbox"/>	<input type="checkbox"/>	_____
- Noise verified on test drive	<input type="checkbox"/>	<input type="checkbox"/>	_____
- Noise source located and repaired	<input type="checkbox"/>	<input type="checkbox"/>	_____
- Follow up test drive performed to confirm repair	<input type="checkbox"/>	<input type="checkbox"/>	_____

VIN: \_\_\_\_\_ Customer Name \_\_\_\_\_

W.O.# \_\_\_\_\_ Date: \_\_\_\_\_

This form must be attached to Work Order

LAIA0071E

A  
B  
C  
D  
E  
F  
G  
H  
I  
IP  
K  
L  
M  
N  
O  
P

# INSTRUMENT PANEL ASSEMBLY

< REMOVAL AND INSTALLATION >

## REMOVAL AND INSTALLATION

### INSTRUMENT PANEL ASSEMBLY

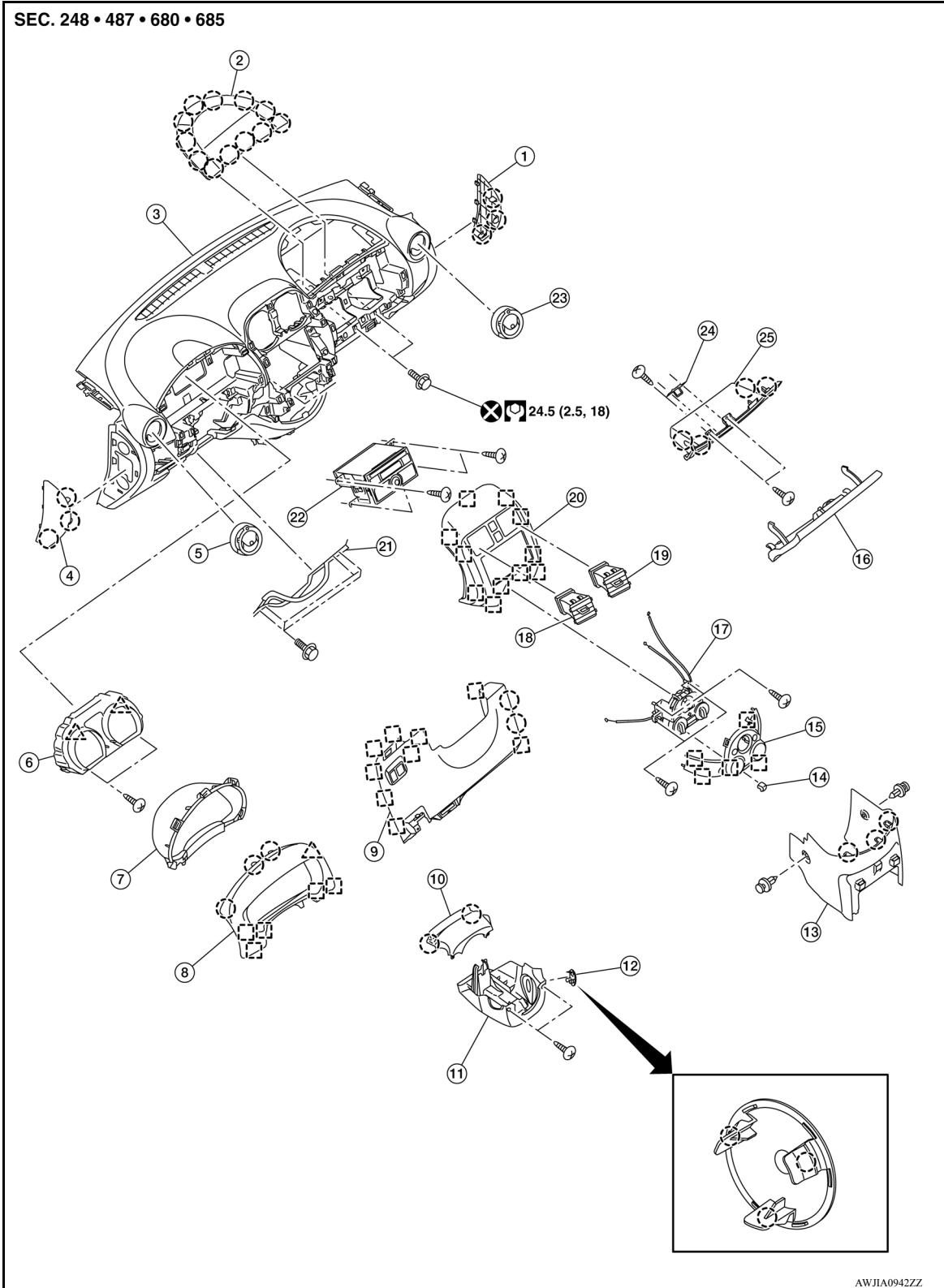

Exploded View

INFOID:000000009266850



# INSTRUMENT PANEL ASSEMBLY

## < REMOVAL AND INSTALLATION >

- |  |  |  |   |
|--|--|--|---|
| 1. Instrument side finisher (RH)   | 2. Passenger air bag module  | 3. Instrument panel assembly   | A |
| 4. Instrument side finisher (LH)   | 5. Ventilator grilles (LH)   | 6. Combination meter   |   |
| 7. Combination meter finisher  | 8. Cluster lid A   | 9. Instrument lower panel LH   | B |
| 10. Steering column upper cover  | 11. Steering column lower cover  | 12. Steering lock escutcheon   |   |
| 13. Center console lower   | 14. Control knob   | 15. A/C control finisher   | C |
| 16. Glove box lid  | 17. A/C control  | 18. Ventilator grilles center (LH)   |   |
| 19. Ventilator grilles center (RH)   | 20. Cluster lid C  | 21. Lower knee protector (LH)  | D |
| 22. Audio unit or AV control unit (if equipped)  | 23. Ventilator grilles (RH)  | 24. Glove box striker  |   |
| 25. Glove box  |  Metal clip |  Clip | E |
|  Pawl |  |  |   |

## Removal and Installation

INFOID:000000009266851

### CAUTION:

- Disconnect both the negative and positive battery terminals, then wait at least three minutes.
- Do not tamper with or force air bag lid open, as this may adversely affect air bag performance.
- To prevent damage to the parts, when removing, always use a suitable tool that is made of plastic.
- Be careful not to scratch instrument panel pad or other parts.

### REMOVAL

1. Disconnect the negative and positive battery terminals, then wait at least three minutes. Refer to [PG-63, "Removal and Installation"](#).
2. Remove front pillar finishers (LH/RH). Refer to [INT-19, "FRONT PILLAR FINISHER : Removal and Installation"](#).
3. Remove dash side finishers (LH/RH). Refer to [INT-21, "DASH SIDE FINISHER : Removal and Installation"](#).
4. Partially remove front body side welts (LH/RH). Refer to [INT-22, "BODY SIDE WELT : Removal and Installation"](#).
5. Release the pawls using a suitable tool and then remove instrument side finisher (LH) by pulling rearward.

 Pawl

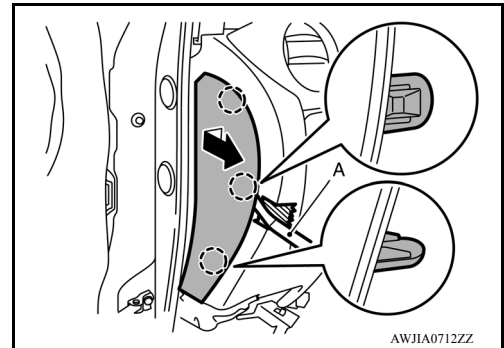

6. Release the pawls using a suitable tool and then remove instrument side finisher (RH) by pulling rearward.

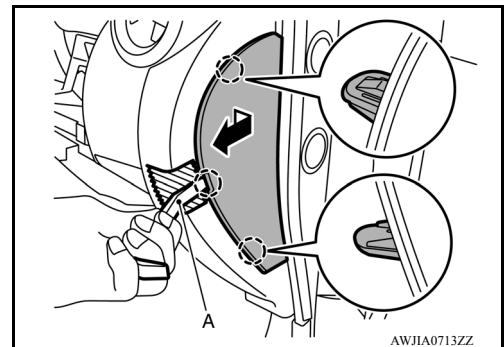

 Pawl



7. Remove center console lower. Refer to [IP-25, "Removal and Installation"](#).
8. Remove steering wheel. Refer to [ST-8, "Removal and Installation"](#).
9. Remove steering column covers. Refer to [IP-18, "Removal and Installation"](#).

# INSTRUMENT PANEL ASSEMBLY

## < REMOVAL AND INSTALLATION >

10. Remove combination switch. Refer to [EXL-107, "Removal and Installation"](#).
11. Remove combination meter. Refer to [MWI-104, "Removal and Installation"](#) (TYPE A) or [MWI-53, "Removal and Installation"](#) (TYPE B).
12. Remove cluster lid C. Refer to [IP-21, "Removal and Installation"](#).
13. Remove audio unit (if equipped), refer to [AV-28, "Removal and Installation"](#) (BASE AUDIO) or [AV-77, "Removal and Installation"](#) (MID AUDIO) or remove AV control unit, refer to [AV-222, "Removal and Installation"](#) (NAVIGATION).
14. Remove A/C control finisher.
  - a. Remove intake door lever knob (1).
  - b. Pull left side of A/C control finisher (2) rearward to release left side metal clips.  
 Metal clip
  - c. Pull right side of A/C control finisher (2) rearward to release right side metal clips and remove A/C control finisher.  
 Metal clip

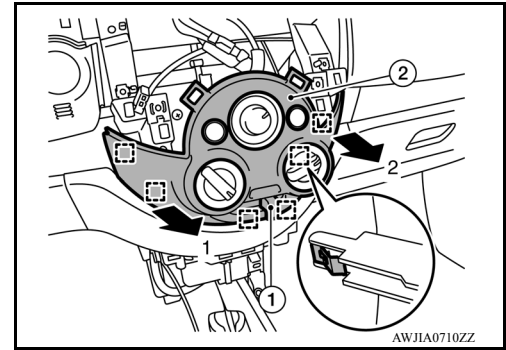

15. Remove A/C control. Refer to [HAC-48, "Removal and Installation"](#).
16. Remove glove box assembly. Refer to [IP-22, "Removal and Installation"](#).
17. Remove passenger air bag module. Refer to [SR-17, "Removal and Installation"](#).
18. Remove instrument panel assembly.
  - a. Remove instrument panel assembly screws (A).

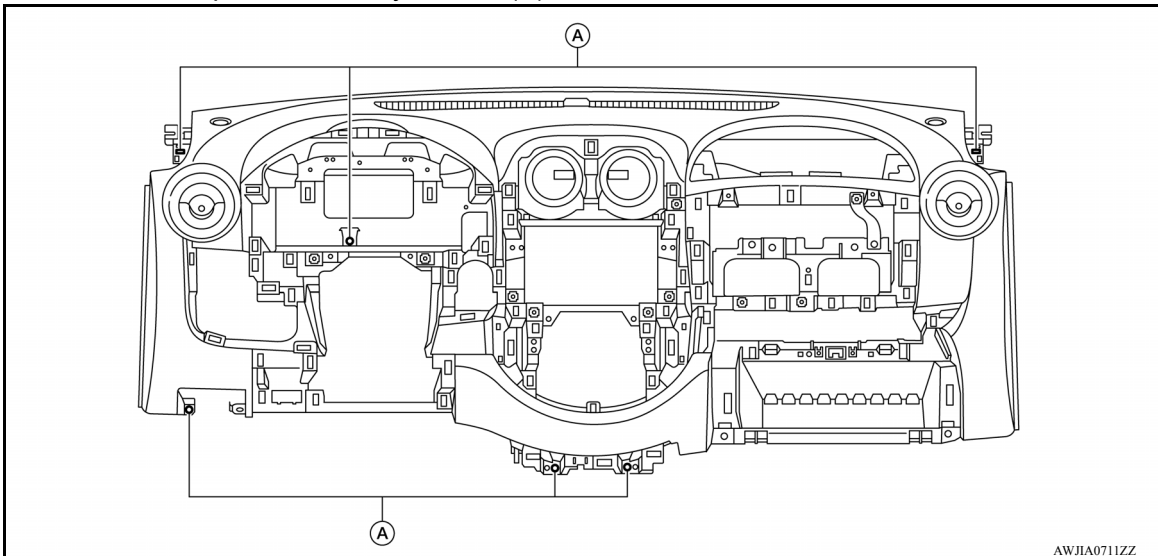

- b. Disengage the harness (A, B) from the instrument panel assembly at the base of each front pillar.

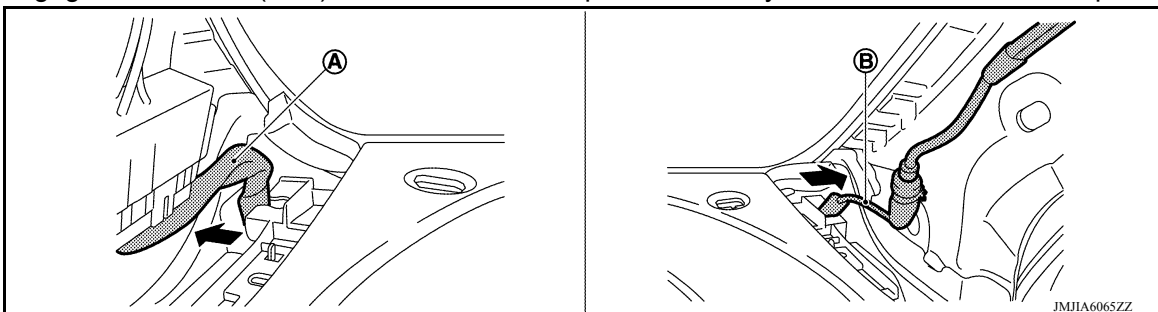

- c. Remove instrument panel assembly through passenger door opening.

### CAUTION:

- Cover shift selector assembly with a shop cloth to prevent damage to instrument panel assembly.



# INSTRUMENT PANEL ASSEMBLY

## < REMOVAL AND INSTALLATION >

- **When removing instrument panel assembly, two people are required to prevent it from dropping.**
19. Removal of the following components is only necessary if replacing the instrument panel assembly.
- Side ventilator grilles (LH/RH): Refer to [VTL-5, "SIDE VENTILATOR GRILLE : Removal and Installation"](#).
  - Center ventilator duct LH/RH: Refer to [VTL-6, "CENTER VENTILATOR DUCT : Removal and Installation"](#).

### INSTALLATION

Installation is in the reverse order of removal.

#### **CAUTION:**

- **Do not reuse the steering wheel nut after removal, replace with a new nut.**
- **Do not reuse the passenger air bag bolts after removal, replace with new bolts.**

A  
B  
C  
D  
E  
F  
G  
H  
I  
IP  
K  
L  
M  
N  
O  
P

# STEERING COLUMN COVERS

< REMOVAL AND INSTALLATION >

## STEERING COLUMN COVERS

### Removal and Installation

INFOID:000000009266852

#### REMOVAL

1. Remove instrument lower panel LH. Refer to [IP-20, "Removal and Installation"](#).
2. Remove lower knee protector (LH) bolts and lower knee protector (LH). Refer to [IP-14, "Exploded View"](#).
3. Remove steering column covers.
  - a. Remove steering column cover screws (A).
  - b. Tilt the steering column to the lowest position.
  - c. Pull steering column upper cover (1) upward to disengage steering column upper cover pawls.  
○: Pawl
  - d. Remove steering column upper cover.
  - e. Pull steering column lower cover (2) downward to remove.

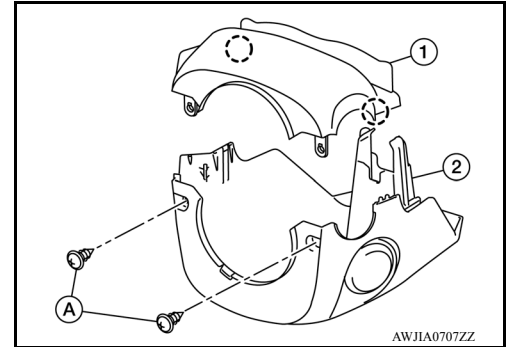

#### INSTALLATION

Installation is in the reverse order of removal.

# CLUSTER LID A

< REMOVAL AND INSTALLATION >

## CLUSTER LID A

### Removal and Installation

INFOID:00000009266853

#### REMOVAL

1. Remove steering column covers. Refer to [IP-18, "Removal and Installation"](#).
2. Remove cluster lid C. Refer to [IP-21, "Removal and Installation"](#).
3. Remove cluster lid A.

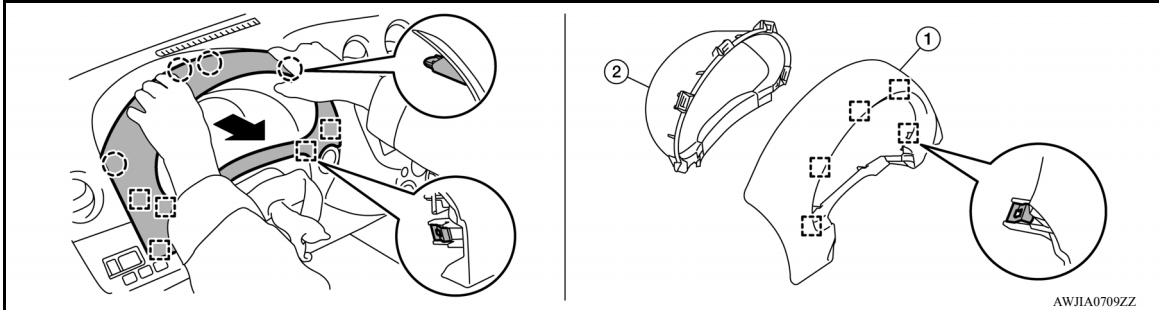

- ○: Pawl
- □: Metal clip

- a. Remove combination meter finisher and cluster lid A as an assembly by pulling rearward to release pawls and metal clips.
- b. Separate cluster lid A (2) from combination meter finisher (1) by releasing the metal clips (If necessary).

#### INSTALLATION

Installation is in the reverse order of removal.

A  
B  
C  
D  
E  
F  
G  
H  
I  
K  
L  
M  
N  
O  
P

IP

# INSTRUMENT LOWER PANEL LH

< REMOVAL AND INSTALLATION >

## INSTRUMENT LOWER PANEL LH

### Removal and Installation

INFOID:000000009266854

#### REMOVAL

1. Remove data link connector from instrument lower panel LH.
2. Remove hood and fuel filler handle assembly bolts (A) and position hood and fuel filler handle assembly aside.

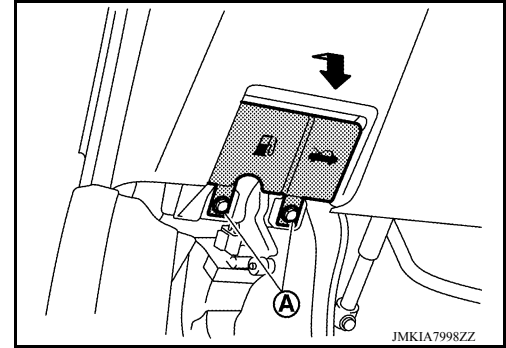

3. Remove instrument lower panel LH. Refer to [IP-14, "Exploded View"](#).
  - a. Release instrument lower panel LH by using a suitable tool to release the pawls and metal clips and pulling rearward.  
**CAUTION:**  
**Disengage pawls and metal clips slowly so that they are not damaged.**
  - b. Disconnect harness connectors from instrument lower panel LH and remove.

#### INSTALLATION

Installation is in the reverse order of removal.

# CLUSTER LID C

< REMOVAL AND INSTALLATION >

## CLUSTER LID C

### Removal and Installation

INFOID:00000009266855

#### REMOVAL

1. Release the metal clips using a suitable tool (A), beginning in the lower left corner of cluster lid C and working in a counter-clockwise direction.  
☐: Metal clip
2. Reposition cluster lid C to access harness connectors.
3. Disconnect harness connectors from cluster lid C and remove.

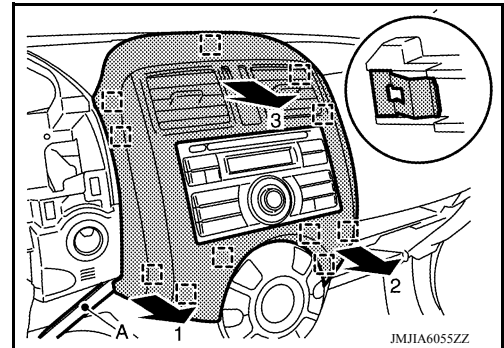

#### INSTALLATION

Installation is in the reverse order of removal.

A  
B  
C  
D  
E  
F  
G  
H  
I  
IP  
K  
L  
M  
N  
O  
P

# GLOVE BOX ASSEMBLY AND HOUSING

< REMOVAL AND INSTALLATION >

## GLOVE BOX ASSEMBLY AND HOUSING

### Removal and Installation

INFOID:000000009266856

#### REMOVAL

1. Remove glove box lid.
  - a. Open glove box lid.
  - b. Pull glove box lid rearward and glove box lid hinges down and rearward to disengage, then remove the glove box lid.

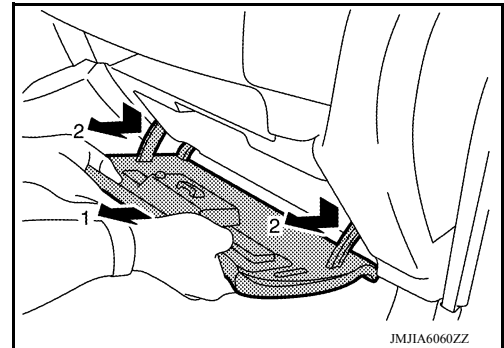

- c. Disconnect glove box damper (if equipped).
  2. Remove glove box assembly.
    - a. Remove glove box assembly screws (A).
    - b. Pull glove box assembly rearward to disengage pawls and remove glove box assembly.
- : Pawl

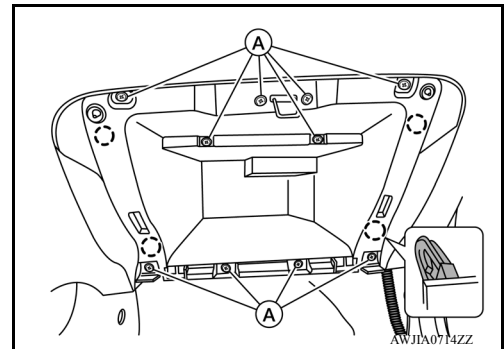

#### INSTALLATION

Installation is in the reverse order of removal.

# CENTER CONSOLE ASSEMBLY

< REMOVAL AND INSTALLATION >

## CENTER CONSOLE ASSEMBLY

Exploded View

INFOID:000000009266857

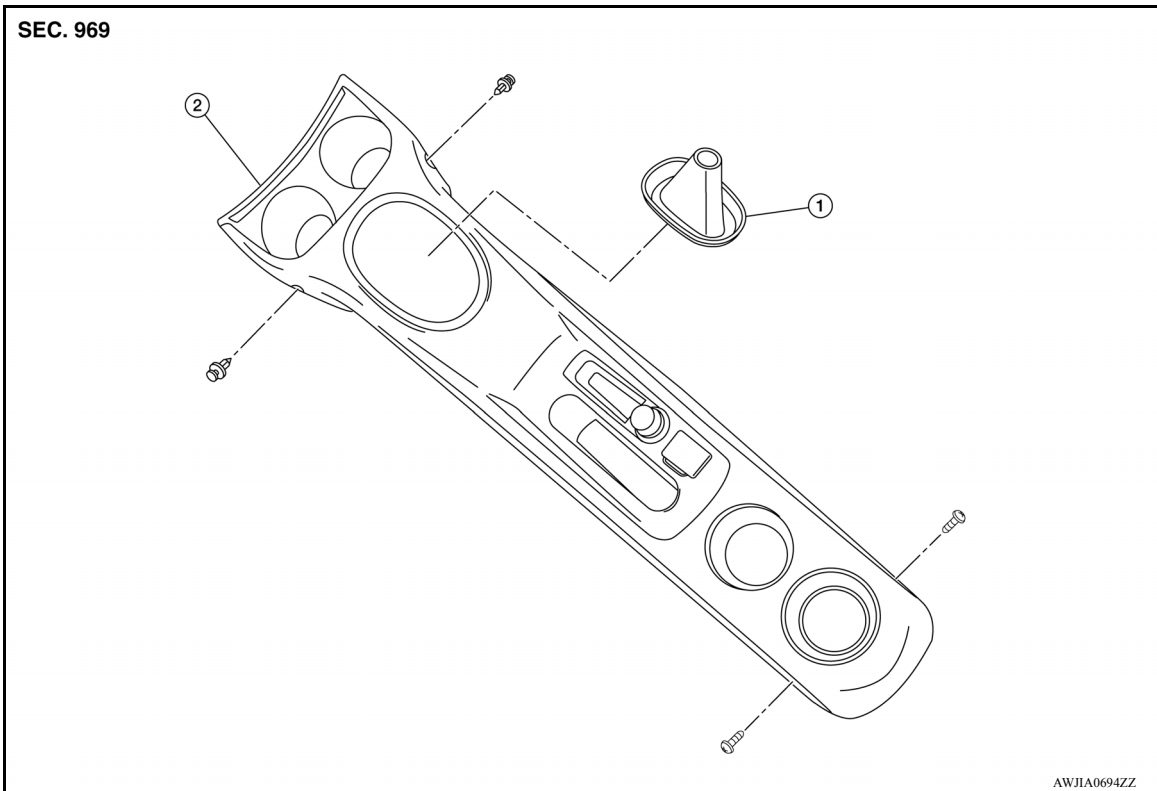

1. M/T console boot (M/T models)
2. Center console assembly

## Removal and Installation

INFOID:000000009266858

### REMOVAL

1. Move shift selector to "N" position (CVT models or A/T models).
2. Remove shift selector handle and console boot (M/T models).
3. Raise parking brake lever.
4. Remove center console assembly clips (A).

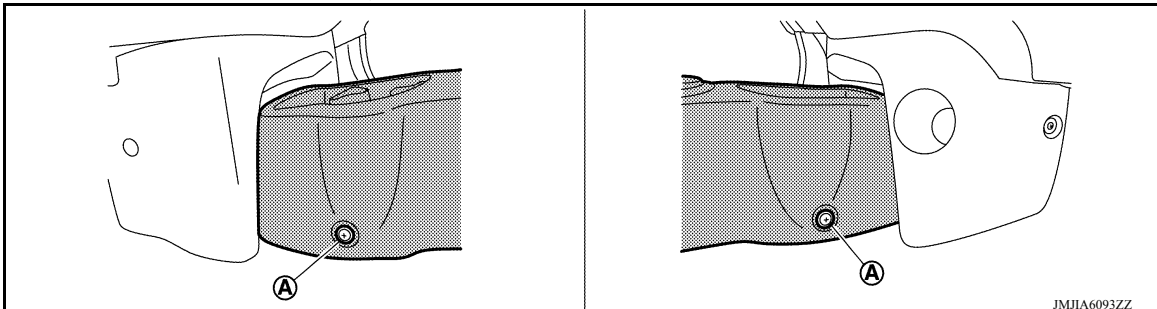

5. Remove the center console assembly rear screws.
6. Slide front seat (RH) all the way rearward and place in fully reclined position.
7. Slide front seat (LH) all the way forward and tilt seatback to the full forward position.

## CENTER CONSOLE ASSEMBLY

### < REMOVAL AND INSTALLATION >

8. Raise rear right corner of center console assembly, rotating slightly, making sure to lift assembly upward over the parking brake handle.
9. Disconnect harness connector from power socket and harness connector from USB/auxiliary jack (if equipped).
10. Remove center console assembly.

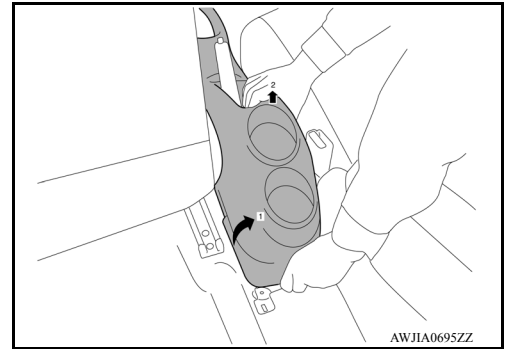

### INSTALLATION

Installation is in the reverse order of removal.



# CENTER CONSOLE LOWER

< REMOVAL AND INSTALLATION >

## CENTER CONSOLE LOWER

### Removal and Installation

INFOID:00000009266859

#### REMOVAL

1. Remove center console assembly. Refer to [IP-23. "Removal and Installation"](#).
2. Remove center console lower.
  - a. Place front seats in a full rearward position.
  - b. Remove center console lower clips (A).

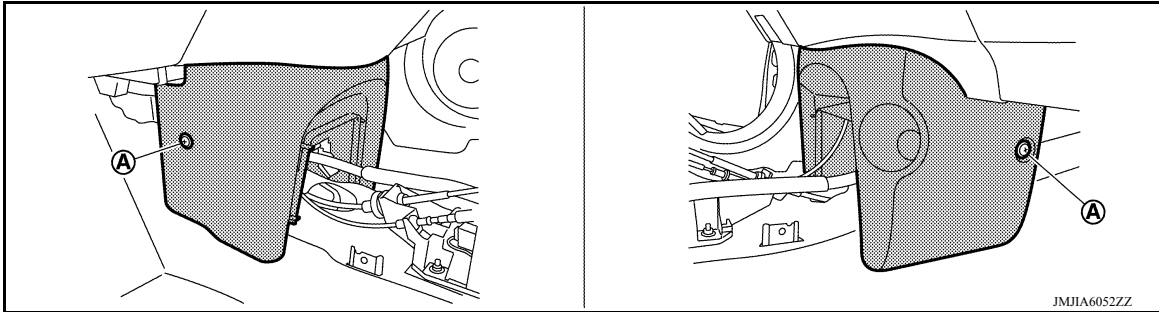

- 
- 
- c. Disengage center console lower pawls and remove center console lower.

○: Pawl

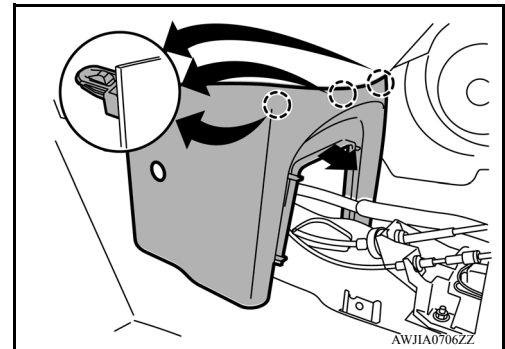

#### INSTALLATION

Installation is in the reverse order of removal.

# CENTER CONSOLE ASSEMBLY

< UNIT DISASSEMBLY AND ASSEMBLY >

## UNIT DISASSEMBLY AND ASSEMBLY

### CENTER CONSOLE ASSEMBLY

Exploded View

INFOID:000000009266860

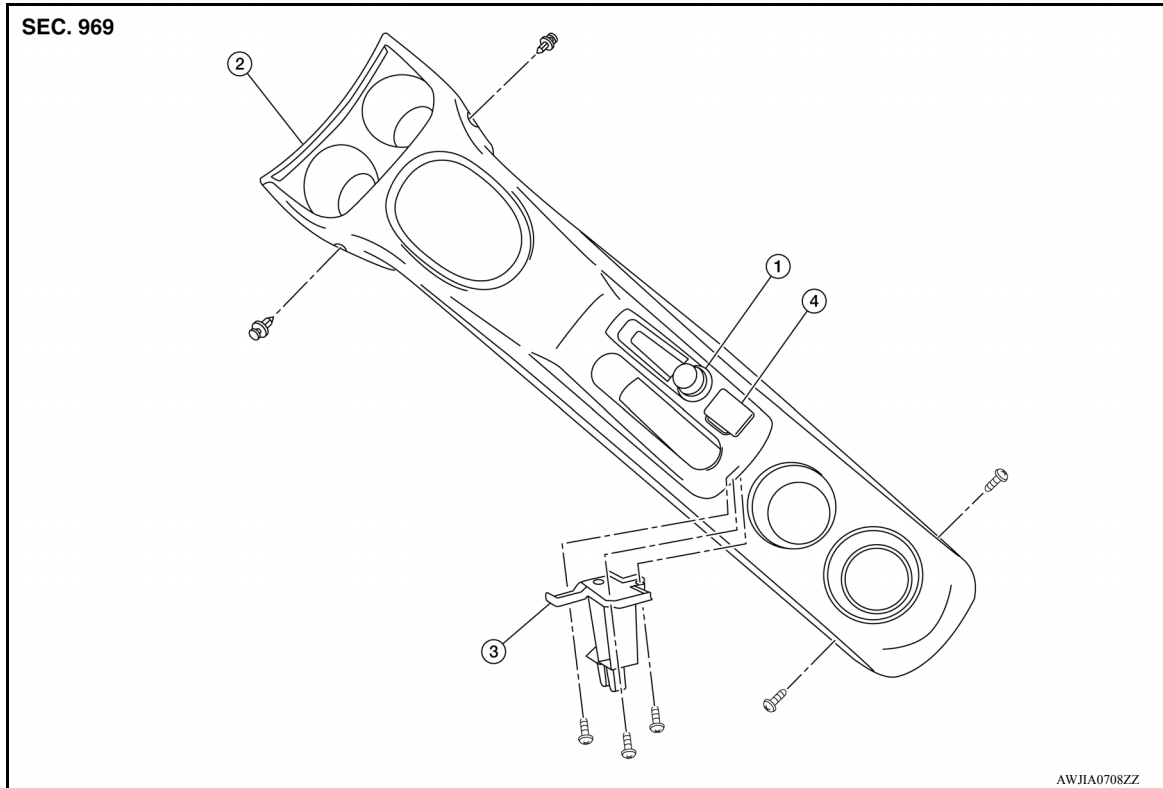

1. Power socket
2. Center console assembly
3. Center console support
4. USB port and auxiliary jack

### Disassembly and Assembly

INFOID:000000009266861

#### DISASSEMBLY

1. Remove the center console assembly. Refer to [IP-23, "Removal and Installation"](#).
2. Remove center console support screws and center console support.
3. Remove power socket. Refer to [PWO-6, "Removal and Installation"](#).
4. Remove USB connector and auxiliary jack (if equipped). Refer to [AV-140, "Removal and Installation"](#) (DISPLAY AUDIO) or [AV-223, "Removal and Installation"](#) (NAVIGATION).

#### ASSEMBLY

Assembly is in the reverse order of disassembly.