

A  
B  
C

# SECTION RAX

## REAR AXLE

RAX

### CONTENTS

|  |   |  |    |   |
|--|---|--|----|---|
| <b>PRECAUTION</b> .....  | 2 | <b>PERIODIC MAINTENANCE</b> .....                  | 5  | F |
| <b>PRECAUTIONS</b> .....   | 2 | <b>REAR WHEEL HUB</b> .....                        | 5  |   |
| Precaution for Supplemental Restraint System (SRS) "AIR BAG" and "SEAT BELT PRE-TENSIONER" ..... | 2 | Inspection .....                                   | 5  | G |
| Precautions for Wheel Hub .....  | 2 | <b>REMOVAL AND INSTALLATION</b> .....              | 6  |   |
| <b>PREPARATION</b> .....   | 3 | <b>REAR WHEEL HUB</b> .....                        | 6  | H |
| <b>PREPARATION</b> .....   | 3 | Exploded View .....                                | 6  |   |
| Special Service Tools .....  | 3 | Removal and Installation .....                     | 6  |   |
| Commercial Service Tool .....  | 3 | Disassembly and Assembly .....                     | 7  | I |
| <b>SYMPTOM DIAGNOSIS</b> .....   | 4 | Inspection .....                                   | 9  |   |
| <b>NOISE, VIBRATION AND HARSHNESS (NVH) TROUBLESHOOTING</b> .....                                | 4 | <b>SERVICE DATA AND SPECIFICATIONS (SDS)</b> ..... | 10 | J |
| NVH Troubleshooting Chart .....  | 4 | <b>SERVICE DATA AND SPECIFICATIONS (SDS)</b> ..... | 10 | K |
|  |   | Wheel Bearing .....                                | 10 |   |
|  |   | Wheel Hub .....                                    | 10 | L |

# PRECAUTIONS

< PRECAUTION >

## PRECAUTION

### PRECAUTIONS

#### Precaution for Supplemental Restraint System (SRS) "AIR BAG" and "SEAT BELT PRE-TENSIONER"

INFOID:000000012431904

The Supplemental Restraint System such as "AIR BAG" and "SEAT BELT PRE-TENSIONER", used along with a front seat belt, helps to reduce the risk or severity of injury to the driver and front passenger for certain types of collision. Information necessary to service the system safely is included in the SR and SB section of this Service Manual.

**WARNING:**

- To avoid rendering the SRS inoperative, which could increase the risk of personal injury or death in the event of a collision which would result in air bag inflation, all maintenance must be performed by an authorized NISSAN/INFINITI dealer.
- Improper maintenance, including incorrect removal and installation of the SRS, can lead to personal injury caused by unintentional activation of the system. For removal of Spiral Cable and Air Bag Module, see the SR section.
- Do not use electrical test equipment on any circuit related to the SRS unless instructed to in this Service Manual. SRS wiring harnesses can be identified by yellow and/or orange harnesses or harness connectors.

#### PRECAUTIONS WHEN USING POWER TOOLS (AIR OR ELECTRIC) AND HAMMERS

**WARNING:**

- When working near the Airbag Diagnosis Sensor Unit or other Airbag System sensors with the Ignition ON or engine running, DO NOT use air or electric power tools or strike near the sensor(s) with a hammer. Heavy vibration could activate the sensor(s) and deploy the air bag(s), possibly causing serious injury.
- When using air or electric power tools or hammers, always switch the Ignition OFF, disconnect the battery and wait at least three minutes before performing any service.

#### Precautions for Wheel Hub

INFOID:000000012431905

Observe the following precautions when assembling wheel hub.

- Perform work in a location that is free from dust, dirt and debris.
- Use paper shop towels while performing repairs. Fabric shop cloths must not be used because of the danger of lint adhering to parts.
- Do not drop any of the components such as the brake drum, wheel bearing, spindle, or wheel hub lock nut. If any of these parts have been dropped, they must be replaced.
- Always check that the tools used to press-fit the wheel bearing to the brake drum have no wear and deformation. Damaged tools will not guarantee that pressure can be applied vertically and damage parts.

# PREPARATION

< PREPARATION >

## PREPARATION

### PREPARATION

#### Special Service Tools

INFOID:000000012431906

The actual shape of the tools may differ from those illustrated here.

| Tool number<br>(TechMate No.)<br>Tool name | Description   |
|--|---|
| ST30720000<br>( — )<br>Drift               | Installing hub cap<br><b>a: 77 mm (3.03 in) dia.</b><br><b>b: 55 mm (2.17 in) dia.</b>  |
| KV40104730<br>( — )<br>Drift               | Installing wheel bearing<br><b>a: 53.7 mm (2.114 in) dia.</b><br><b>b: 47 mm (1.85 in) dia.</b><br><b>c: 15 mm (0.59 in).</b> |
| ST33710000<br>( — )<br>Drift               | Removing wheel bearing<br><b>a: 30 mm (1.18 in) dia.</b><br><b>b: 23 mm (0.91 in) dia.</b>                                    |
| ST30032000<br>( — )<br>Drift               | Installing sensor rotor<br><b>a: 38 mm (1.50 in) dia.</b><br><b>b: 80 mm (3.15 in) dia.</b>                                   |

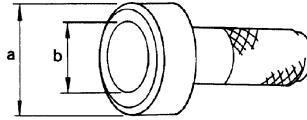

ZZA0701D

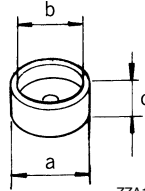

ZZA1133D

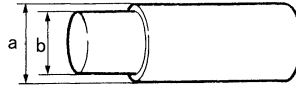

ZZA1234D

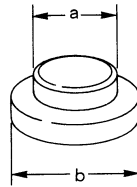

ZZA0881D

#### Commercial Service Tool

INFOID:000000012431907

| Tool name  | Description                      |
|------------|----------------------------------|
| Power tool | Loosening nuts, screws and bolts |



PIB1407E

# NOISE, VIBRATION AND HARSHNESS (NVH) TROUBLESHOOTING

< SYMPTOM DIAGNOSIS >

## SYMPTOM DIAGNOSIS

### NOISE, VIBRATION AND HARSHNESS (NVH) TROUBLESHOOTING

#### NVH Troubleshooting Chart

INFOID:000000012431908

Use chart below to find the cause of the symptom. If necessary, repair or replace these parts.

| Reference page                     |                               | <a href="#">RSU-5</a>            | —                  | <a href="#">RAX-5</a> | <a href="#">RSU-4</a> | <a href="#">WT-43</a> | <a href="#">WT-45</a> | <a href="#">BR-7</a> |
|------------------------------------|-------------------------------|----------------------------------|--------------------|-----------------------|-----------------------|-----------------------|-----------------------|----------------------|
| Possible cause and SUSPECTED PARTS |                               | Improper installation, looseness | Parts interference | Wheel bearing damage  | REAR SUSPENSION       | TIRE                  | ROAD WHEEL            | BRAKE                |
| Symptom                            | Noise                         | x                                | x                  | x                     | x                     | x                     | x                     | x                    |
|                                    | Shake                         | x                                | x                  | x                     | x                     | x                     | x                     | x                    |
|                                    | Vibration                     | x                                | x                  | x                     | x                     | x                     |                       |                      |
|                                    | Shimmy                        | x                                | x                  |                       | x                     | x                     | x                     | x                    |
|                                    | Shudder                       | x                                |                    |                       | x                     | x                     | x                     | x                    |
|                                    | Poor quality ride or handling | x                                | x                  |                       | x                     | x                     | x                     |                      |

x: Applicable

# REAR WHEEL HUB

< PERIODIC MAINTENANCE >

## PERIODIC MAINTENANCE

### REAR WHEEL HUB

#### Inspection

INFOID:0000000012431909

- Check the axle and suspension parts for excessive play, wear, or damage.
- Shake each rear wheel to check for excessive play as shown.

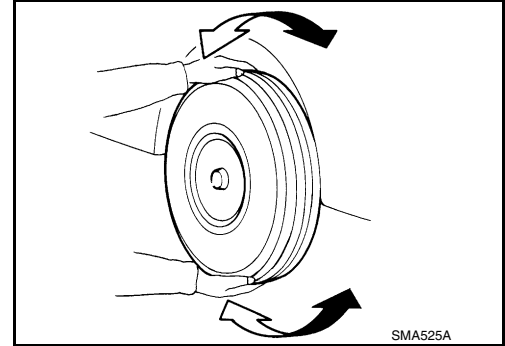

#### REAR WHEEL BEARING INSPECTION

- Move wheel in the axial direction by hand. Make sure the axial end play is within specification.

**Axial end play** : Refer to [RAX-10, "Wheel Bearing"](#).

- Check that the wheel bearing operates smoothly.
- Replace the wheel bearing if the axial end play exceeds specification, or if the wheel bearing does not turn smoothly. Refer to [RAX-6, "Removal and Installation"](#).

**CAUTION:**

The wheel bearing does not require maintenance. If any of the following symptoms are noted, replace the wheel bearing.

- Growling noise is emitted from the wheel bearing during operation.
- Wheel bearing drags or turns roughly.

# REAR WHEEL HUB

< REMOVAL AND INSTALLATION >

## REMOVAL AND INSTALLATION

### REAR WHEEL HUB

Exploded View

INFOID:000000012431910

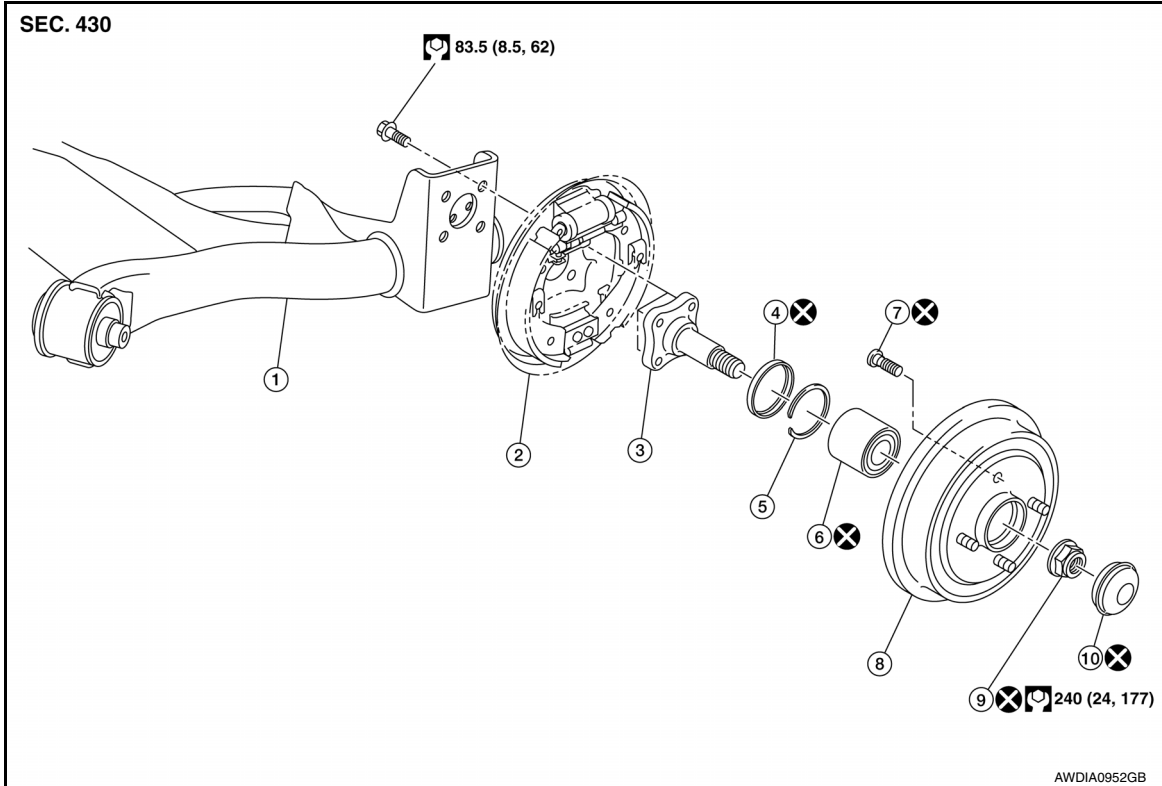

- |                         |                          |                       |
|-------------------------|--------------------------|-----------------------|
| 1. Rear suspension beam | 2. Rear brake components | 3. Spindle            |
| 4. Sensor rotor         | 5. Snap ring             | 6. Wheel bearing      |
| 7. Wheel stud           | 8. Brake drum            | 9. Wheel hub lock nut |
| 10. Hub cap             |                          |                       |

### Removal and Installation

INFOID:000000012431911

#### REMOVAL

1. Remove the wheel and tire using power tool. Refer to [WT-48. "Removal and Installation"](#).
2. Separate rear wheel sensor from back plate. Refer to [BRC-141. "REAR WHEEL SENSOR : Exploded View"](#).  
**CAUTION:**  
**When removing rear wheel hub, first separate rear wheel sensor from back plate. Failure to do so may result in damage to rear wheel sensor wires, making rear wheel sensor inoperative.**
3. Remove hub cap from brake drum using a suitable tool.
4. Remove wheel hub lock nut and brake drum.  
**CAUTION:**
  - Do not depress brake pedal while rear drum is removed.
  - Do not apply force to the brake drum to avoid damage to the wheel bearing. If the wheel bearing inner race is separated due to force, replace the wheel bearing with a new one.
5. Remove spindle bolts. Separate back plate and spindle from rear suspension beam.  
**CAUTION:**  
**Do not remove rear brake components. Support the rear brake components using wire.**
6. If required, remove the wheel studs from brake drum using a suitable press.  
**CAUTION:**

# REAR WHEEL HUB

## < REMOVAL AND INSTALLATION >

- Do not hammer the wheel stud and avoid impact to the brake drum.
- Press the wheel stud straight out to avoid damage.

7. Perform inspection after removal. Refer to [RAX-9, "Inspection"](#).

### INSTALLATION

Installation is in the reverse order of removal.

- Position the stud (1) to the brake drum. Place a washer (A) on the opposite end of the stud and by use of a nut (B), tighten to press the stud into the brake drum.

**Wheel stud press-fit load** : Refer to [RAX-10, "Wheel Hub"](#).

#### CAUTION:

- Check that no clearance exists between brake drum, and the wheel stud after installation.
- Do not reuse wheel stud.

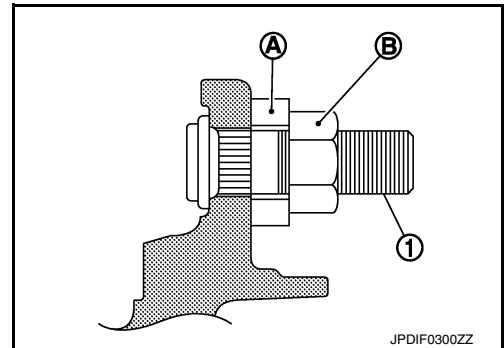

- Insert brake drum in a straight line onto the spindle.

#### CAUTION:

- If the brake drum becomes stuck and must be pulled out, do not use tools. Replace the wheel bearing with a new one if the brake drum cannot be pulled out without use of tools.
  - If the brake drum becomes stuck and the wheel bearing inner race is damaged, replace the wheel bearing with a new one.
  - Do not damage the wheel bearing seal. If damaged, replace wheel bearing with new one.
- Using the Tool, install hub cap on brake drum as shown.

**Tool number** : ST30720000 ( — )

#### CAUTION:

- Do not reuse hub cap.
- Do not reuse wheel hub lock nut.
- Tighten the wheel hub lock nut to the specified torque. Refer to [RAX-6, "Exploded View"](#).

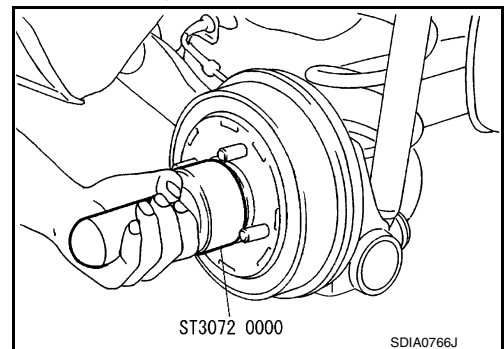

- Perform inspection after installation. Refer to [RAX-9, "Inspection"](#).

## Disassembly and Assembly

INFOID:000000012431912

### DISASSEMBLY

1. Remove sensor rotor, using a suitable tool (A).

#### CAUTION:

Do not damage the brake drum.

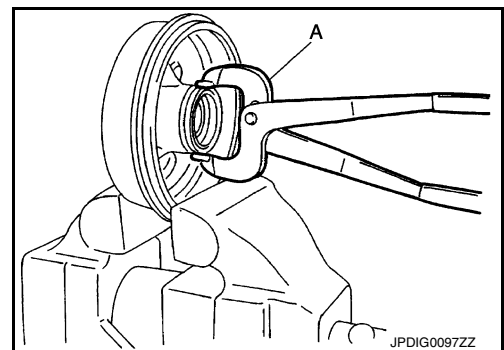

A  
B  
C  
RAX  
E  
F  
G  
H  
I  
J  
K  
L  
M  
N  
O  
P

# REAR WHEEL HUB

## < REMOVAL AND INSTALLATION >

2. Remove snap ring (1).

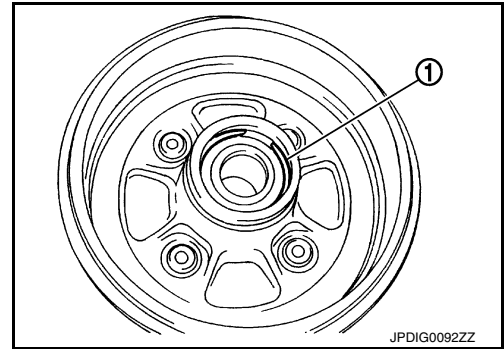

3. Remove wheel bearing, using the Tool.

**Tool number** : ST33710000 ( — )

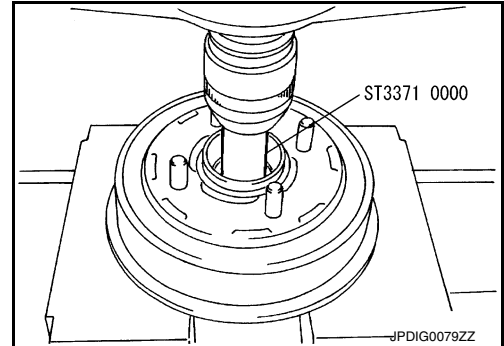

4. Perform inspection after disassembly. Refer to [RAX-9. "Inspection"](#).

## ASSEMBLY

1. Install wheel bearing (1) to brake drum (2), using the Tool (A).

**Tool number (A)** : KV40104730 ( — )

### CAUTION:

- Do not reuse wheel bearing.
- Do not apply lubricating oil to the press-fit surface of the wheel hub bearing.
- Install wheel bearing with the seal rubber part (B) faced to the brake drum side.
- Set brake drum and wheel bearing horizontally and insert them vertically.
- The press-fit load must be applied to the wheel bearing outer race and the brake drum.
- Do not apply press-fit load to the wheel bearing inner race, the seal (B) on the rubber surface side, and the seal (C) on the metallic surface side. If a press-fit load is applied, the wheel bearing must be replaced with a new one.

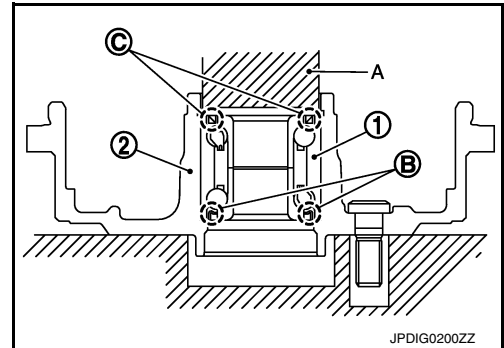

**Wheel bearing press-fit load** : Refer to [RAX-10. "Wheel Bearing"](#).

2. Install snap ring to brake drum.

### CAUTION:

- Do not damage the wheel bearing seal.
- The snap ring must be installed evenly into the groove.



# REAR WHEEL HUB

## < REMOVAL AND INSTALLATION >

3. Install sensor rotor, using the Tool (A).

**Tool number (A) : ST30032000 ( — )**

**CAUTION:**

**Do not reuse sensor rotor.**

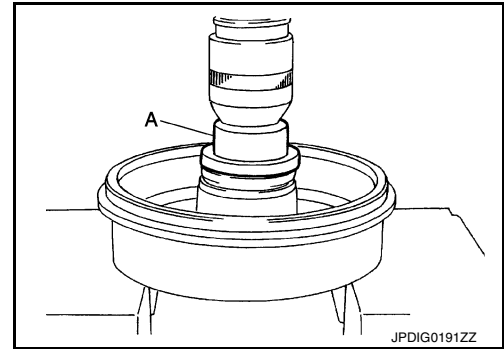

INFOID:000000012431913

## Inspection

### INSPECTION AFTER REMOVAL

Check the brake drum and spindle for wear, cracks, and damage. Replace if necessary.

### INSPECTION AFTER DISASSEMBLY

- Check brake drum for wear, cracks, or any other damage. Replace if necessary.
- Check snap ring for wear or cracks. Replace if necessary.

### INSPECTION AFTER INSTALLATION

1. Check wheel bearing rotating torque per the following instructions.

**NOTE:**

The adequacy of turning torque can be judged from a measurement value by a suitable tool.

- a. Check the contact surface of the brake drum and spindle for foreign matter. If there is any foreign matter, clean the contact surface.
- b. Check that the wheel hub lock nut is tightened to the specified torque.
- c. Turn the brake drum 10 times or more both clockwise and counterclockwise for proper fit.
- d. Set a suitable tool to the wheel nut and measure turning torque at turning speeds of 8 to 12 rpm.

**Wheel bearing rotating torque : Refer to [RAX-10, "Wheel Bearing"](#).**

2. Adjust parking brake operation (stroke). Refer to [PB-4, "Inspection and Adjustment"](#).

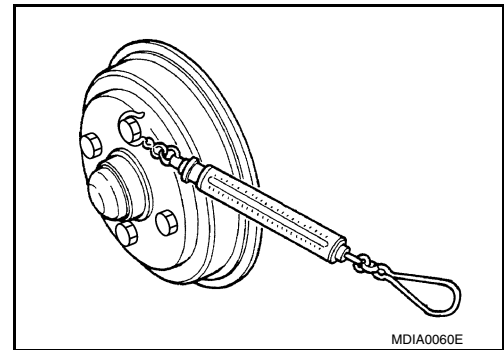

## SERVICE DATA AND SPECIFICATIONS (SDS)

< SERVICE DATA AND SPECIFICATIONS (SDS)

## SERVICE DATA AND SPECIFICATIONS (SDS)

### SERVICE DATA AND SPECIFICATIONS (SDS)

#### Wheel Bearing

INFOID:0000000012431914

| Item                         | Standard   |
|------------------------------|--|
| Axial end play               | 0.0 mm (0.00 in) or less   |
| Rotating torque              | 1.71 N·m (0.17 kg-m, 15 in-lb) or less                           |
| Spring balance measurement   | 34.2 N (3.49 kg, 7.69 lb) or less                                |
| Wheel bearing press-fit load | 44.1 - 53.9 kN (4,498.2 - 5,497.8 kg-f, 9,913.7 - 12,116.7 lb-f) |

#### Wheel Hub

INFOID:0000000012431915

| Item                      | Standard  |
|---------------------------|---|
| Wheel stud press-fit load | 26.5 - 32.3 kN (2,703.0 - 3,294.6 kg-f, 5,957.2 - 7,261.0 lb-f) |