

A
B
AT
D
E
F
G
H
I
J
K
L
M
N
O
P

SECTION **AT**

AUTOMATIC TRANSAXLE

CONTENTS

<p>SERVICE INFORMATION 5</p> <p>INDEX FOR DTC 5</p> <p style="padding-left: 20px;">Alphabetical Index5</p> <p style="padding-left: 20px;">DTC No. Index5</p> <p>PRECAUTIONS 7</p> <p style="padding-left: 20px;">Precaution for Supplemental Restraint System (SRS) "AIR BAG" and "SEAT BELT PRE-TENSIONER"7</p> <p style="padding-left: 20px;">Precaution Necessary for Steering Wheel Rotation After Battery Disconnect7</p> <p style="padding-left: 20px;">Precaution for On Board Diagnosis (OBD) System of A/T and Engine8</p> <p style="padding-left: 20px;">Precaution8</p> <p style="padding-left: 20px;">Service Notice or Precaution9</p> <p>PREPARATION11</p> <p style="padding-left: 20px;">Special Service Tool 11</p> <p style="padding-left: 20px;">Commercial Service Tool 14</p> <p>A/T FLUID17</p> <p style="padding-left: 20px;">Checking A/T Fluid 17</p> <p style="padding-left: 20px;">Changing A/T Fluid 17</p> <p style="padding-left: 20px;">A/T Fluid Cooler Cleaning 18</p> <p>A/T CONTROL SYSTEM21</p> <p style="padding-left: 20px;">Cross-Sectional View21</p> <p style="padding-left: 20px;">Shift Mechanism22</p> <p style="padding-left: 20px;">TCM Function30</p> <p style="padding-left: 20px;">CAN Communication31</p> <p style="padding-left: 20px;">Input/Output Signal of TCM31</p> <p style="padding-left: 20px;">Line Pressure Control32</p> <p style="padding-left: 20px;">Shift Control33</p> <p style="padding-left: 20px;">Lock-up Control34</p> <p style="padding-left: 20px;">Engine Brake Control (Overrun Clutch Control)35</p> <p style="padding-left: 20px;">Control Valve37</p> <p style="padding-left: 20px;">Centrifugal Cancel Mechanism37</p> <p>ON BOARD DIAGNOSTIC (OBD) SYSTEM39</p> <p style="padding-left: 20px;">Introduction39</p> <p style="padding-left: 20px;">OBD-II Function for A/T System39</p>	<p style="padding-left: 20px;">One or Two Trip Detection Logic of OBD-II39</p> <p style="padding-left: 20px;">OBD-II Diagnostic Trouble Code (DTC)39</p> <p style="padding-left: 20px;">Malfunction Indicator Lamp (MIL)41</p> <p>TROUBLE DIAGNOSIS42</p> <p style="padding-left: 20px;">DTC Inspection Priority Chart42</p> <p style="padding-left: 20px;">Fail-Safe42</p> <p style="padding-left: 20px;">How to Perform Trouble Diagnosis for Quick and Accurate Repair43</p> <p style="padding-left: 20px;">A/T Electrical Parts Location49</p> <p style="padding-left: 20px;">Circuit Diagram50</p> <p style="padding-left: 20px;">Inspections Before Trouble Diagnosis51</p> <p style="padding-left: 20px;">Road Test55</p> <p style="padding-left: 20px;">Check Before Engine Is Started56</p> <p style="padding-left: 20px;">Check at Idle56</p> <p style="padding-left: 20px;">Cruise Test - Part 158</p> <p style="padding-left: 20px;">Cruise Test - Part 261</p> <p style="padding-left: 20px;">Cruise Test - Part 362</p> <p style="padding-left: 20px;">Vehicle Speed at Which Gear Shifting Occurs64</p> <p style="padding-left: 20px;">Vehicle Speed at Which Lock-up Occurs/Releases64</p> <p style="padding-left: 20px;">Symptom Chart65</p> <p style="padding-left: 20px;">TCM Terminal and Reference Value75</p> <p style="padding-left: 20px;">CONSULT-III Function (TRANSMISSION)77</p> <p style="padding-left: 20px;">Diagnosis Procedure without CONSULT-III82</p> <p>U1000 CAN COMM CIRCUIT87</p> <p style="padding-left: 20px;">Description87</p> <p style="padding-left: 20px;">On Board Diagnosis Logic87</p> <p style="padding-left: 20px;">Possible Cause87</p> <p style="padding-left: 20px;">DTC Confirmation Procedure87</p> <p style="padding-left: 20px;">Wiring Diagram - AT - CAN88</p> <p style="padding-left: 20px;">Diagnosis Procedure89</p> <p>P0705 TRANSMISSION RANGE SWITCH A ...90</p> <p style="padding-left: 20px;">Description90</p> <p style="padding-left: 20px;">CONSULT-III Reference Value in Data Monitor Mode90</p> <p style="padding-left: 20px;">On Board Diagnosis Logic90</p> <p style="padding-left: 20px;">Possible Cause90</p> <p style="padding-left: 20px;">DTC Confirmation Procedure90</p>
--	---

Wiring Diagram - AT - TR/SW	91	CONSULT-III Reference Value in Data Monitor	
Diagnosis Procedure	92	Mode	118
Component Inspection	94	On Board Diagnosis Logic	118
P0710 TRANSMISSION FLUID TEMPERATURE SENSOR A	95	Possible Cause	118
Description	95	DTC Confirmation Procedure	118
CONSULT-III Reference Value in Data Monitor		Diagnosis Procedure	119
Mode	95	P0740 TORQUE CONVERTER	123
On Board Diagnosis Logic	95	Description	123
Possible Cause	95	CONSULT-III Reference Value in Data Monitor	
DTC Confirmation Procedure	95	Mode	123
Wiring Diagram - AT - FTS	96	On Board Diagnosis Logic	123
Diagnosis Procedure	96	Possible Cause	123
Component Inspection	99	DTC Confirmation Procedure	123
P0720 OUTPUT SPEED SENSOR	100	Wiring Diagram - AT - TCV	124
Description	100	Diagnosis Procedure	125
CONSULT-III Reference Value in Data Monitor		Component Inspection	126
Mode	100	P0744 TORQUE CONVERTER	128
On Board Diagnosis Logic	100	Description	128
Possible Cause	100	CONSULT-III Reference Value in Data Monitor	
DTC Confirmation Procedure	100	Mode	128
Wiring Diagram - AT - VSSA/T	101	On Board Diagnosis Logic	128
Diagnosis Procedure	102	Possible Cause	128
P0725 ENGINE SPEED	105	DTC Confirmation Procedure	128
Description	105	Diagnosis Procedure	129
CONSULT-III Reference Value in Data Monitor		P0745 PRESSURE CONTROL SOLENOID A	133
Mode	105	Description	133
On Board Diagnosis Logic	105	CONSULT-III Reference Value in Data Monitor	
Possible Cause	105	Mode	133
DTC Confirmation Procedure	105	On Board Diagnosis Logic	133
Wiring Diagram - AT - ENGSS	106	Possible Cause	133
Diagnosis Procedure	107	DTC Confirmation Procedure	133
P0731 1GR INCORRECT RATIO	109	Wiring Diagram - AT - LPSV	134
Description	109	Diagnosis Procedure	135
On Board Diagnosis Logic	109	Component Inspection	137
Possible Cause	109	P0750 SHIFT SOLENOID A	138
DTC Confirmation Procedure	109	Description	138
Diagnosis Procedure	110	CONSULT-III Reference Value in Data Monitor	
P0732 2GR INCORRECT RATIO	112	Mode	138
Description	112	On Board Diagnosis Logic	138
On Board Diagnosis Logic	112	Possible Cause	138
Possible Cause	112	DTC Confirmation Procedure	138
DTC Confirmation Procedure	112	Wiring Diagram - AT - SSV/A	139
Diagnosis Procedure	113	Diagnosis Procedure	140
P0733 3GR INCORRECT RATIO	115	Component Inspection	141
Description	115	P0755 SHIFT SOLENOID B	143
On Board Diagnosis Logic	115	Description	143
Possible Cause	115	CONSULT-III Reference Value in Data Monitor	
DTC Confirmation Procedure	115	Mode	143
Diagnosis Procedure	116	On Board Diagnosis Logic	143
P0734 4GR INCORRECT RATIO	118	Possible Cause	143
Description	118	DTC Confirmation Procedure	143
		Wiring Diagram - AT - SSV/B	144
		Diagnosis Procedure	145
		Component Inspection	146

P1760 OVERRUN CLUTCH SOLENOID	148	TCM Terminal and Reference Value	171	
Description	148	Diagnosis Procedure	171	A
CONSULT-III Reference Value in Data Monitor		Component Inspection	175	
Mode	148	SHIFT POSITION INDICATOR CIRCUIT	176	B
On Board Diagnosis Logic	148	Description	176	
Possible Cause	148	CONSULT-III Reference Value in Data Monitor		
DTC Confirmation Procedure	148	Mode	176	
Wiring Diagram - AT - OVRCSV	149	Diagnosis Procedure	176	AT
Diagnosis Procedure	150	TROUBLE DIAGNOSIS FOR SYMPTOMS	177	
Component Inspection	151	Wiring Diagram - AT - NONDTC	177	D
VEHICLE SPEED SIGNAL	153	OD OFF Indicator Lamp Does Not Come On	180	
Description	153	Engine Cannot Be Started in "P" and "N" Position.	182	E
CONSULT-III Reference Value in Data Monitor		In "P" Position, Vehicle Moves Forward or Back-		
Mode	153	ward When Pushed	183	
On Board Diagnosis Logic	153	In "N" Position, Vehicle Moves	183	F
Possible Cause	153	Large Shock "N" → "R" Position	184	
DTC Confirmation Procedure	153	Vehicle Does Not Creep Backward in "R" Position.	185	
Wiring Diagram - AT - VSSMTR	154	Vehicle Does Not Creep Forward in "D", "2" or "1"		
Diagnosis Procedure	155	Position	186	G
BATT/FLUID TEMP SEN	156	Vehicle Cannot Be Started from D1	187	
Description	156	A/T Does Not Shift: D1→ D2or Does Not Kick-		
CONSULT-III Reference Value in Data Monitor		down: D4→ D2	189	H
Mode	156	A/T Does Not Shift: D2→ D3	190	
On Board Diagnosis Logic	156	A/T Does Not Shift: D3→ D4	192	
Possible Cause	156	A/T Does Not Perform Lock-up	193	I
DTC Confirmation Procedure	156	A/T Does Not Hold Lock-up Condition	194	
Wiring Diagram - AT - BA/FTS	157	Lock-up Is Not Released	195	J
Diagnosis Procedure	158	Engine Speed Does Not Return to Idle (Light		
Component Inspection	160	Braking D4→ D3)	196	K
INPUT SPEED SENSOR A	162	A/T Does Not Shift: D4→ D3, When OD OFF	197	
Description	162	A/T Does Not Shift: D3→ 22, When Selector Lever		
CONSULT-III Reference Value in Data Monitor		"D" → "2" Position	198	L
Mode	162	A/T Does Not Shift: 22→ 11, When Selector Lever		
On Board Diagnosis Logic	162	"2" → "1" Position	199	M
Possible Cause	162	Vehicle Does Not Decelerate by Engine Brake	201	
DTC Confirmation Procedure	162	TCM Self-Diagnosis Does Not Activate	204	N
Wiring Diagram - AT - PT/SEN	163	A/T SHIFT LOCK SYSTEM	206	
Diagnosis Procedure	164	Description	206	O
CONTROL UNIT (RAM), CONTROL UNIT		Shift Lock System Parts Location	207	
(ROM)	167	Wiring Diagram - AT - SHIFT	208	P
Description	167	Diagnosis Procedure	208	
On Board Diagnosis Logic	167	TRANSMISSION CONTROL MODULE	212	
Possible Cause	167	Removal and Installation	212	
DTC Confirmation Procedure	167	SHIFT CONTROL SYSTEM	213	
Diagnosis Procedure	167	A/T Shift Selector Removal and Installation	213	
MAIN POWER SUPPLY AND GROUND CIR-		A/T Shift Selector Disassembly and Assembly	216	
CUIT	168	Shift Selector Handle Removal and Installation ...	216	
Wiring Diagram - AT - MAIN	168	Adjustment of A/T Position	217	
Diagnosis Procedure	169	Checking of A/T Position	217	
TR SW, OD SW AND CLOSED THROTTLE,		KEY INTERLOCK CABLE	219	
WIDE OPEN THROTTLE POSITION SIGNAL		Removal and Installation	219	
CIRCUIT	171	ON-VEHICLE SERVICE	222	
CONSULT-III Reference Value in Data Monitor		Control Valve Assembly and Accumulators	222	
Mode	171			

Transmission Range Switch	225	Adjustment (1) (For HR16DE Engine Models)	345
Output Speed Sensor	227	Adjustment (1) (For MR18DE Engine Models)	349
Input Speed Sensor	228	Assembly (2)	355
Differential Side Oil Seal	229	Adjustment (2)	360
AIR BREATHER HOSE	232	Assembly (3)	363
Removal and Installation	232	SERVICE DATA AND SPECIFICATIONS	
TRANSAXLE ASSEMBLY	233	(SDS)	373
Removal and Installation	233	General Specification	373
OVERHAUL	237	Vehicle Speed at Which Gear Shifting Occurs	373
Component	237	Vehicle Speed at When Lock-up Occurs/Releases	. 373
Oil Channel	250	Stall Speed	374
Location of Adjusting Shims, Needle Bearings and		Line Pressure	374
Thrust Washers	253	Adjusting shims, Needle Bearings, Thrust Wash-	
Location of Snap Rings	255	ers and Snap Rings	374
DISASSEMBLY	257	Control Valves	375
Disassembly	257	Accumulator	376
REPAIR FOR COMPONENT PARTS	275	Clutches and Brakes	376
Manual Shaft	275	Final Drive	378
Oil Pump	278	Planetary Carrier	378
Control Valve Assembly	281	Oil Pump	378
Control Valve Upper Body	290	Input Shaft	378
Control Valve Lower Body	294	Reduction Pinion Gear	378
Reverse Clutch	297	Band Servo	378
High Clutch	302	Output Shaft	379
Forward and Overrun Clutches	307	Bearing Retainer	379
Low & Reverse Brake	314	Total End Play	379
Rear Internal Gear and Forward Clutch Hub	318	Reverse Clutch End Play	379
Output Shaft, Output Gear, Idler Gear, Reduction		Removal and Installation	379
Pinion Gear and Bearing Retainer	322	Shift Solenoid Valves	379
Band Servo Piston Assembly	331	Solenoid Valves	380
Final Drive	337	A/T Fluid Temperature Sensor	380
ASSEMBLY	344	Output Speed Sensor	380
Assembly (1)	344	Dropping Resistor	380
		Input Speed Sensor	380

INDEX FOR DTC

< SERVICE INFORMATION >

SERVICE INFORMATION

INDEX FOR DTC

Alphabetical Index

INFOID:000000005928061

NOTE:

If DTC “CAN COMM CIRCUIT” is displayed with other DTCs, first perform the trouble diagnosis for DTC “CAN COMM CIRCUIT”. Refer to [AT-87](#).

Items (CONSULT-III screen terms)	DTC*1	Reference page
	CONSULT-III or GST	
BATT/FLUID TEMP SEN	—	AT-156
CAN COMM CIRCUIT	U1000	AT-87
CONTROL UNIT (RAM)	—	AT-167
CONTROL UNIT (ROM)	—	AT-167
ENGINE SPEED	P0725	AT-105
FLUID TEMP SENSOR A	P0710	AT-95
INPUT SPEED SENSOR A	—	AT-162
OUTPUT SPEED SENSOR*3	P0720	AT-100
OVER CLUTCH SOLENOID	P1760	AT-148
PC SOLENOID A	P0745	AT-133
SHIFT SOLENOID A*2	P0750	AT-138
SHIFT SOLENOID B*2	P0755	AT-143
TORQUE CONVERTER	P0740	AT-123
TORQUE CONVERTER	P0744	AT-128
T/M RANGE SENSOR A	P0705	AT-90
VHCL SPEED SEN-MTR	—	AT-153
1GR INCORRECT RATIO	P0731	AT-109
2GR INCORRECT RATIO	P0732	AT-112
3GR INCORRECT RATIO	P0733	AT-115
4GR INCORRECT RATIO	P0734	AT-118

*1: These numbers is prescribed by SAE J2012.

*2: When the fail-safe operation occurs, the MIL illuminates.

*3: The MIL illuminates when both the “Output speed sensor signal” and the “Vehicle speed signal” meet the fail-safe condition at the same time.

DTC No. Index

INFOID:000000005928062

NOTE:

If DTC “CAN COMM CIRCUIT” is displayed with other DTCs, first perform the trouble diagnosis for DTC “CAN COMM CIRCUIT”. Refer to [AT-87](#).

DTC*1	Items (CONSULT-III screen terms)	Reference page
CONSULT-III or GST		
P0705	T/M RANGE SENSOR A	AT-90
P0710	FLUID TEMP SENSOR A	AT-95
P0720	OUTPUT SPEED SENSOR*3	AT-100
P0725	ENGINE SPEED	AT-105
P0731	1GR INCORRECT RATIO	AT-109

INDEX FOR DTC

< SERVICE INFORMATION >

DTC*1 CONSULT-III or GST	Items (CONSULT-III screen terms)	Reference page
P0732	2GR INCORRECT RATIO	AT-112
P0733	3GR INCORRECT RATIO	AT-115
P0734	4GR INCORRECT RATIO	AT-118
P0740	TORQUE CONVERTER	AT-123
P0744	TORQUE CONVERTER	AT-128
P0745	PC SOLENOID A	AT-133
P0750	SHIFT SOLENOID A*2	AT-138
P0755	SHIFT SOLENOID B*2	AT-143
P1760	OVER CLUTCH SOLENOID	AT-148
U1000	CAN COMM CIRCUIT	AT-87
—	BATT/FLUID TEMP SEN	AT-156
—	CONTROL UNIT (RAM)	AT-167
—	CONTROL UNIT (ROM)	AT-167
—	INPUT SPEED SENSOR A	AT-162
—	VHCL SPEED SEN-MTR	AT-153

*1: These numbers is prescribed by SAE J2012.

*2: When the fail-safe operation occurs, the MIL illuminates.

*3: The MIL illuminates when both the “utput speed sensor signal” and the “Vehicle speed signal” meet the fail-safe condition at the same time.

PRECAUTIONS

< SERVICE INFORMATION >

PRECAUTIONS

Precaution for Supplemental Restraint System (SRS) "AIR BAG" and "SEAT BELT PRE-TENSIONER"

INFOID:000000006413332

The Supplemental Restraint System such as "AIR BAG" and "SEAT BELT PRE-TENSIONER", used along with a front seat belt, helps to reduce the risk or severity of injury to the driver and front passenger for certain types of collision. This system includes seat belt switch inputs and dual stage front air bag modules. The SRS system uses the seat belt switches to determine the front air bag deployment, and may only deploy one front air bag, depending on the severity of a collision and whether the front occupants are belted or unbelted. Information necessary to service the system safely is included in the SRS and SB section of this Service Manual.

WARNING:

- To avoid rendering the SRS inoperative, which could increase the risk of personal injury or death in the event of a collision which would result in air bag inflation, all maintenance must be performed by an authorized NISSAN/INFINITI dealer.
- Improper maintenance, including incorrect removal and installation of the SRS can lead to personal injury caused by unintentional activation of the system. For removal of Spiral Cable and Air Bag Module, see the SRS section.
- Do not use electrical test equipment on any circuit related to the SRS unless instructed to in this Service Manual. SRS wiring harnesses can be identified by yellow and/or orange harnesses or harness connectors.

PRECAUTIONS WHEN USING POWER TOOLS (AIR OR ELECTRIC) AND HAMMERS

WARNING:

- When working near the Airbag Diagnosis Sensor Unit or other Airbag System sensors with the Ignition ON or engine running, DO NOT use air or electric power tools or strike near the sensor(s) with a hammer. Heavy vibration could activate the sensor(s) and deploy the air bag(s), possibly causing serious injury.
- When using air or electric power tools or hammers, always switch the Ignition OFF, disconnect the battery, and wait at least 3 minutes before performing any service.

Precaution Necessary for Steering Wheel Rotation After Battery Disconnect

INFOID:000000005928064

NOTE:

- This Procedure is applied only to models with Intelligent Key system and NVIS/IVIS (NISSAN/INFINITI VEHICLE IMMOBILIZER SYSTEM - NATS).
- Remove and install all control units after disconnecting both battery cables with the ignition knob in the "LOCK" position.
- Always use CONSULT-III to perform self-diagnosis as a part of each function inspection after finishing work. If DTC is detected, perform trouble diagnosis according to self-diagnostic results.

For models equipped with the Intelligent Key system and NVIS/IVIS, an electrically controlled steering lock mechanism is adopted on the key cylinder.

For this reason, if the battery is disconnected or if the battery is discharged, the steering wheel will lock and steering wheel rotation will become impossible.

If steering wheel rotation is required when battery power is interrupted, follow the procedure below before starting the repair operation.

OPERATION PROCEDURE

1. Connect both battery cables.

NOTE:

Supply power using jumper cables if battery is discharged.

2. Use the Intelligent Key or mechanical key to turn the ignition switch to the "ACC" position. At this time, the steering lock will be released.
3. Disconnect both battery cables. The steering lock will remain released and the steering wheel can be rotated.
4. Perform the necessary repair operation.
5. When the repair work is completed, return the ignition switch to the "LOCK" position before connecting the battery cables. (At this time, the steering lock mechanism will engage.)

A
B
AT
D
E
F
G
H
I
J
K
L
M
N
O
P

PRECAUTIONS

< SERVICE INFORMATION >

6. Perform a self-diagnosis check of all control units using CONSULT-III.

Precaution for On Board Diagnosis (OBD) System of A/T and Engine

INFOID:000000005928065

The ECM has an on board diagnostic system. It will light up the malfunction indicator lamp (MIL) to warn the driver of a malfunction causing emission deterioration.

CAUTION:

- Be sure to turn the ignition switch OFF and disconnect battery negative cable from battery negative terminal before any repair or inspection work. The open/short circuit of related switches, sensors, solenoid valves, etc. will cause the MIL to light up.
- Be sure to connect and lock the connectors securely after work. A loose (unlocked) connector will cause the MIL to light up due to an open circuit. (Be sure the connectors are free from water, grease, dirt, bent terminals, etc.)
- Be sure to route and secure the harnesses properly after work. Interference of the harness with a bracket, etc. may cause the MIL to light up due to a short circuit.
- Be sure to erase the unnecessary malfunction information (repairs completed) from the TCM and ECM before returning the vehicle to the customer.

Precaution

INFOID:000000005928066

- Before connecting or disconnecting the TCM harness connector, turn ignition switch OFF and disconnect the battery cable from the negative terminal. Failure to do so may damage the TCM. Because battery voltage is applied to TCM even if ignition switch is turned off.

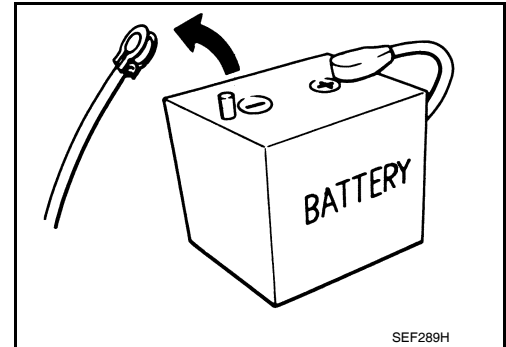

- When connecting or disconnecting pin connectors into or from TCM, take care not to damage pin terminals (bend or break). Make sure that there are not any bends or breaks on TCM pin terminal, when connecting pin connectors.

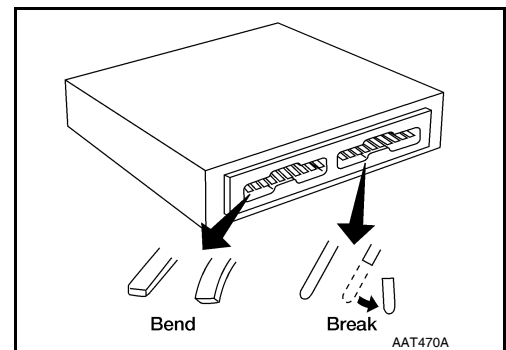

- Before replacing TCM, perform TCM input/output signal inspection and make sure whether TCM functions properly or not. (See page [AT-75, "TCM Terminal and Reference Value"](#).)
- After performing each TROUBLE DIAGNOSIS, perform "DTC (Diagnostic Trouble Code) Confirmation Procedure". The DTC should not be displayed in the "DTC Confirmation Procedure" if the repair is completed.
- Before proceeding with disassembly, thoroughly clean the outside of the transaxle. It is important to prevent the internal parts from becoming contaminated by dirt or other foreign matter.
- Disassembly should be done in a clean work area.
- Use lint-free cloth or towels for wiping parts clean. Common shop rags can leave fibers that could interfere with the operation of the A/T.
- Place disassembled parts in order for easier and proper assembly.
- All parts should be carefully cleaned with a general purpose, non-flammable solvent before inspection or reassembly.

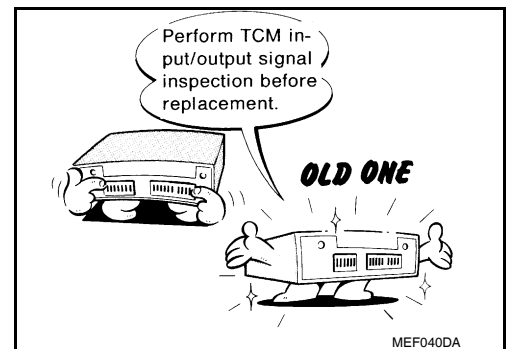

PRECAUTIONS

< SERVICE INFORMATION >

- Gaskets, seals and O-rings should be replaced any time the A/T is disassembled.
- It is very important to perform functional tests whenever they are indicated.
- The valve body contains precision parts and requires extreme care when parts are removed and serviced. Place disassembled valve body parts in order for easier and proper assembly. Care will also prevent springs and small parts from becoming scattered or lost.
- Properly installed valves, sleeves, plugs, etc. will slide along bores in valve body under their own weight.
- Before assembly, apply a coat of recommended ATF to all parts. Apply petroleum jelly to protect O-rings and seals, or hold bearings and washers in place during assembly. Do not use grease.
- Extreme care should be taken to avoid damage to O-rings, seals and gaskets when assembling.
- Clean or replace ATF cooler if excessive foreign material is found in oil pan or clogging strainer. Refer to [AT-18, "A/T Fluid Cooler Cleaning"](#).
- After overhaul, refill the A/T with new ATF.
- When the A/T drain plug is removed, only some of the fluid is drained. Old A/T fluid will remain in torque converter and ATF cooling system.
Always follow the procedures under "Changing A/T Fluid" in the AT section when changing A/T fluid. Refer to [AT-17, "Changing A/T Fluid"](#), [AT-17, "Checking A/T Fluid"](#).

Service Notice or Precaution

INFOID:000000005928067

ATF COOLER SERVICE

If A/T fluid contains frictional material (clutches, bands, etc.), or if an A/T is repaired, overhauled, or replaced, inspect and clean the A/T oil cooler mounted in the radiator or replace the radiator. Flush cooler lines using cleaning solvent and compressed air after repair. Check Service Bulletins for latest A/T oil cooler cleaning procedure. For radiator replacement, refer to [CO-16, "Removal and Installation"](#) (HR16DE engine models), [CO-40, "Removal and Installation"](#) (MR18DE engine models).

TORQUE CONVERTER SERVICE

The torque converter should be replaced under any of the following conditions:

- External leaks in the hub weld area.
- Converter hub is scored or damaged.
- Converter pilot is broken, damaged or fits poorly into crankshaft.
- Steel particles are found after flushing the cooler and cooler lines.
- Pump is damaged or steel particles are found in the converter.
- Vehicle has TCC shudder and/or no TCC apply. Replace only after all hydraulic and electrical diagnoses have been made. (Converter clutch material may be glazed.)
- Converter is contaminated with engine coolant containing antifreeze.
- Internal malfunction of stator roller clutch.
- Heavy clutch debris due to overheating (blue converter).
- Steel particles or clutch lining material found in fluid filter or on magnet when no internal parts in unit are worn or damaged — indicates that lining material came from converter.

The torque converter should not be replaced if:

- The fluid has an odor, is discolored, and there is no evidence of metal or clutch facing particles.
- The threads in one or more of the converter bolt holes are damaged.
- A/T malfunction did not display evidence of damaged or worn internal parts, steel particles or clutch plate lining material in unit and inside the fluid filter.
- Vehicle has been exposed to high mileage (only). The exception may be where the torque converter clutch dampener plate lining has seen excess wear by vehicles operated in heavy and/or constant traffic, such as taxi, delivery or police use.

OBD-II SELF-DIAGNOSIS

- A/T self-diagnosis is performed by the TCM in combination with the ECM. The results can be read through the blinking pattern of the OD OFF indicator lamp or the malfunction indicator lamp (MIL). Refer to the table on [AT-82, "Diagnosis Procedure without CONSULT-III"](#) for the indicator used to display each self-diagnostic result.
- The self-diagnostic results indicated by the MIL are automatically stored in both the ECM and TCM memories.
Always perform the procedure "HOW TO ERASE DTC" on [AT-39, "OBD-II Diagnostic Trouble Code \(DTC\)"](#) to complete the repair and avoid unnecessary blinking of the MIL.
- The following self-diagnostic items can be detected using ECM self-diagnostic results mode* only when the OD OFF indicator lamp does not indicate any malfunctions.
 - Transmission range switch
 - A/T 1GR, 2GR, 3GR, or 4GR function

PRECAUTIONS

< SERVICE INFORMATION >

*: For details of OBD-II, refer to [AT-39](#).

- **Certain systems and components, especially those related to OBD, may use a new style slide-locking type harness connector.**

For description and how to disconnect, refer to [PG-65](#).

PREPARATION

< SERVICE INFORMATION >

PREPARATION

Special Service Tool

INFOID:000000005928068

The actual shapes of Kent-Moore tools may differ from those of special service tools illustrated here.

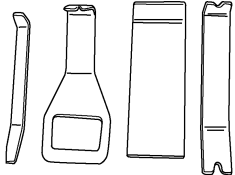
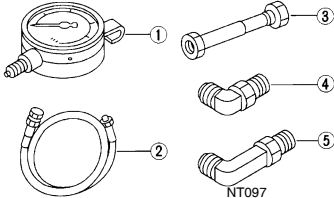
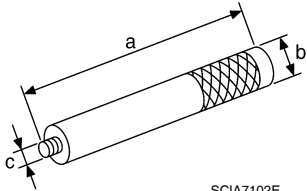
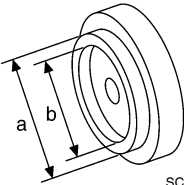
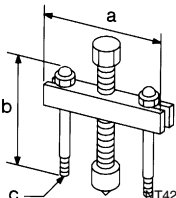
Tool number (Kent-Moore No.) Tool name	Description
<p>— (J-46534) Trim tool set</p>  <p style="text-align: center;">AWJJA0483ZZ</p>	<p>For removing trim</p>
<p>ST2505S001 (J-34301) Oil pressure gauge set</p> <ol style="list-style-type: none"> 1. ST25051001 (J-34301) Oil pressure gauge 2. ST25052000 (J-34301) Hose 3. ST25053000 (J-25695-3) Joint pipe 4. ST25054000 (J-25695-4) Adapter 5. ST25055000 (J-25695-5) Adapter  <p style="text-align: center;">NT097</p>	<p>Measuring line pressure</p>
<p>ST35325000 (—) Drift</p>  <p style="text-align: center;">SCIA7102E</p>	<p>Installing LH differential side oil seal (Use with KV31103000) a: 215 mm (8.46 in) b: 25 mm (0.98 in) dia. c: M12 X 1.5P</p>
<p>KV31103000 (J-38982) Drift</p>  <p style="text-align: center;">SCIA7103E</p>	<p>Installing LH differential side oil seal (Use with ST35325000) a: 59 mm (2.32 in) dia. b: 49 mm (1.93 in) dia.</p>
<p>ST27180001 (J-25726-A) Puller</p>  <p style="text-align: center;">NT424</p>	<ul style="list-style-type: none"> • Removing idler gear • Removing output gear (HR16DE engine models) <p>a: 100 mm (3.94 in) b: 110 mm (4.33 in) c: M8 X 1.25P</p>

A

B

AT

D

E

F

G

H

I

J

K

L

M

N

O

P

PREPARATION

< SERVICE INFORMATION >

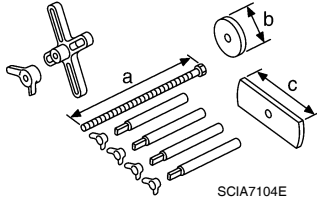
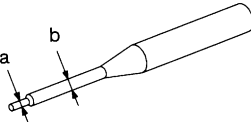
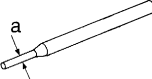
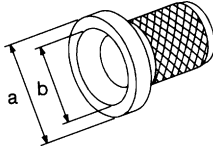
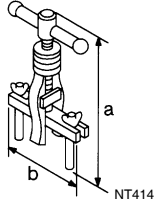
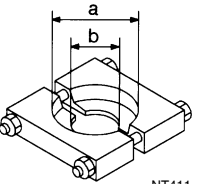
Tool number (Kent-Moore No.) Tool name	Description
KV31103200 (J-39186) Clutch spring compressor  SCIA7104E	<ul style="list-style-type: none"> Removing and installing clutch spring retainer assembly Removing and installing cancel cover a: 179 mm (7.05 in) b: 76 mm (2.99 in) dia. c: 174 mm (6.85 in)
ST23540000 (J-25689-A) Pin punch  NT442	<ul style="list-style-type: none"> Removing and installing retaining pin of manual plate Installing retaining pin of manual shaft Installing retaining pin of parking rod plate a: 2.3 mm (0.091 in) dia. b: 4 mm (0.16 in) dia.
KV32101000 (J-25689-A) Pin punch  NT410	Removing and installing lock pin of pinion mate shaft a: 4 mm (0.16 in) dia.
ST33400001 (J-26082) Drift  NT086	<ul style="list-style-type: none"> Installing oil pump housing oil seal Installing output gear bearing outer race (HR16DE engine models) a: 60 mm (2.36 in) dia. b: 47 mm (1.85 in) dia.
KV381054S0 (J-34286) Puller  NT414	<ul style="list-style-type: none"> Removing radial needle bearing Removing idler gear bearing outer race (HR16DE engine models) Remove output gear bearing outer race (HR16DE engine models) Removal radial needle bearing (MR18DE engine models) Removing differential side bearing outer races (MR18DE engine models) a: 250 mm (9.84 in) b: 160 mm (6.30 in)
ST30031000 (J-22912-01) Puller  NT411	Removing reduction pinion gear bearing inner race a: 90 mm (3.54 in) dia. b: 50 mm (1.97 in) dia.

PREPARATION

< SERVICE INFORMATION >

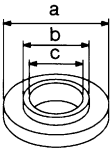
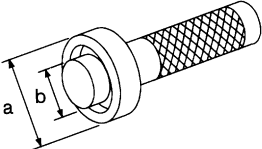
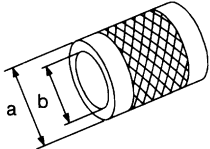
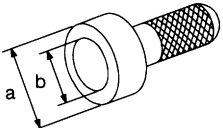
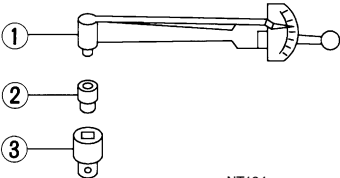
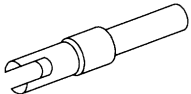
Tool number (Kent-Moore No.) Tool name	Description	
ST35272000 (J-26092) Drift <div style="text-align: center;">  <p>NT107</p> </div>	<ul style="list-style-type: none"> Installing reduction pinion gear bearing inner race Installing idler gear bearing inner race Installing output gear bearing inner race (HR16DE engine models) <p>a: 72 mm (2.83 in) dia. b: 40 mm (1.57 in) dia. c: 35.5 mm (1.398 in) dia.</p>	A B AT
ST37830000 (—) Drift <div style="text-align: center;">  <p>NT084</p> </div>	Installing idler gear bearing outer race a: 61.9 mm (2.437 in) dia. b: 39 mm (1.54 in) dia.	D E F
ST33200000 (J-26082) Drift <div style="text-align: center;">  <p>NT091</p> </div>	Installing differential side bearings (HR16DE engine models) a: 60 mm (2.36 in) dia. b: 44.5 mm (1.752 in) dia.	G H
ST35271000 (J-26091) Drift <div style="text-align: center;">  <p>NT115</p> </div>	<ul style="list-style-type: none"> Installing idler gear Installing output gear (HR16DE engine models) <p>a: 72 mm (2.83 in) dia. b: 63 mm (2.48 in) dia.</p>	I J K
ST3127S000 (J-25765-A) Preload gauge 1. GG9103000 (J-25765-A) Torque wrench 2. HT62940000 (—) Socket adapter 3. HT62900000 (—) Socket adapter <div style="text-align: center;">  <p>NT124</p> </div>	<ul style="list-style-type: none"> Measuring turning torque of reduction pinion gear Measuring turning torque of output shaft (HR16DE engine models) Measuring turning torque of final drive assembly (MR18DE engine models) 	L M N
KV38105710 (J-39026) Preload adapter <div style="text-align: center;">  <p>NT087</p> </div>	<ul style="list-style-type: none"> Selecting differential side bearing adjusting shim (MR18DE engine models) Measuring turning torque of final drive assembly (MR18DE engine models) 	O P

PREPARATION

< SERVICE INFORMATION >

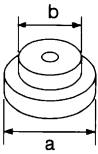
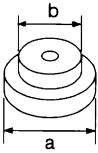
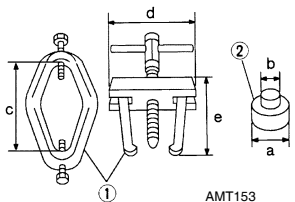
Tool number (Kent-Moore No.) Tool name	Description
ST35321000 (—) Drift <div style="text-align: center;">  <p>NT073</p> </div>	Installing output shaft bearing (MR18DE engine models) a: 49 mm (1.93 in) dia. b: 41 mm (1.61 in) dia.
ST30633000 (—) Drift <div style="text-align: center;">  <p>NT073</p> </div>	Installing differential side bearing outer races (MR18DE engine models) a: 67 mm (2.48 in) dia. b: 49 mm (1.93 in) dia.
ST3306S001 (J-22888-D) Differential side bearing puller set 1. ST33051001 Puller 2. ST33061000 Adapter <div style="text-align: center;">  <p>AMT153</p> </div>	Removing differential side bearing inner race (MR18DE engine models) a: 38 mm (1.50 in) dia. b: 28.5 mm (1.122 in) dia. c: 130 mm (5.12 in) d: 135 mm (5.31 in) e: 100 mm (3.94 in)

Commercial Service Tool

INFOID:000000005928069

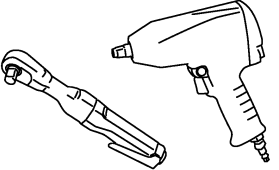
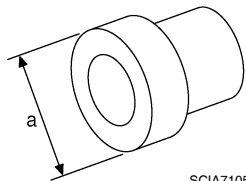
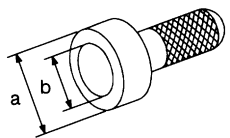
Tool name	Description
Power tool <div style="text-align: center;">  <p>PBIC0190E</p> </div>	Loosening bolts and nuts
Drift <div style="text-align: center;">  <p>SCIA7105E</p> </div>	Installing manual shaft oil seal a: 22 mm (0.87 in) dia.
Drift <div style="text-align: center;">  <p>NT115</p> </div>	Installing RH differential side oil seal a: 54 mm (2.13 in) dia. b: 47 mm (1.85 in) dia.

PREPARATION

< SERVICE INFORMATION >

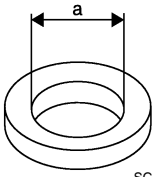
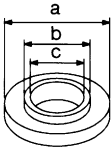
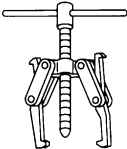
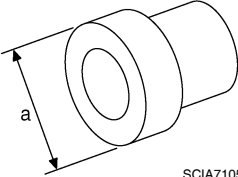
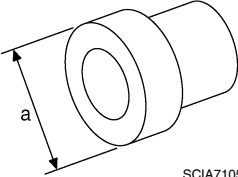
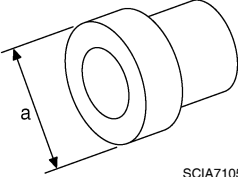
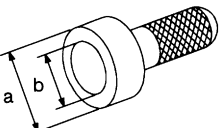
Tool name	Description
Drift  SCIA8471E	Removing output shaft inner race (HR16DE engine models) a: 35 mm (1.38 in) dia.
Drift  NT107	Installing output shaft bearing inner race (HR16DE engine models) a: 70 mm (2.76 in) dia. b: 47 mm (1.85 in) dia. c: 31 mm (1.22 in) dia.
Puller  NT077	<ul style="list-style-type: none"> • Removing idler gear bearing inner race • Removing and installing band servo piston snap ring • Removing output gear bearing inner race (HR16DE engine models) • Removing differential side bearings (HR16DE engine models)
Drift  SCIA7105E	Removing output gear bearing inner race (HR16DE engine models) a: 33 mm (1.30 in) dia.
Drift  SCIA7105E	Removing idler gear bearing inner race a: 34 mm (1.34 in) dia.
Drift  SCIA7105E	Removing differential side bearings (HR16DE engine models) a: 38 mm (1.50 in) dia.
Drift  NT115	Installing differential side bearings (MR18DE engine models) a: 45 mm (1.77 in) dia. b: 41 mm (1.61 in) dia.

A

B

AT

D

E

F

G

H

I

J

K

L

M

N

O

P

PREPARATION

< SERVICE INFORMATION >

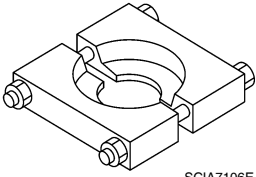
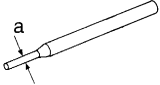
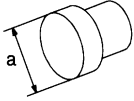
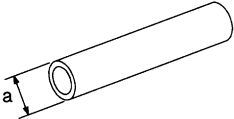
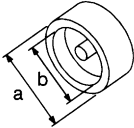
Tool name	Description
<p>Puller</p>  <p style="text-align: right;">SCIA7106E</p>	<p>Removing differential side bearing (HR16DE engine models)</p>
<p>Pin punch</p>  <p style="text-align: right;">NT410</p>	<p>Aligning groove of manual shaft and hole of transaxle case a: 2 mm (0.08 in) dia.</p>
<p>Drift</p>  <p style="text-align: right;">NT109</p>	<p>Removing idler gear bearing inner race (MR18DE engine models) a: 34mm (1.34 in) dia.</p>
<p>Drift</p>  <p style="text-align: right;">NT083</p>	<p>Installing radial needle bearing on bearing retainer (MR18DE engine models) a: 36 mm (1.42 in) dia.</p>
<p>Drift</p>  <p style="text-align: right;">NT108</p>	<p>Installing output shaft bearing outer race (HR16DE engine models) a: 49 mm (1.93 in) dia. b: 42 mm (1.65 in) dia.</p>

A/T FLUID

< SERVICE INFORMATION >

A/T FLUID

Checking A/T Fluid

INFOID:000000005928070

1. Warm up engine.
2. Check for A/T fluid leakage.
3. Before driving, A/T fluid level can be checked at A/T fluid temperatures of 30° to 50°C (86° to 122°F) using the "COLD" range on A/T fluid level gauge.
 - A : Front side
 - B : Reverse side
 - C : Add
 - D : OK

- a. Park vehicle on level surface and set parking brake.
- b. Start engine and move selector lever through each gear position. Leave selector lever in "P" position.
- c. Check A/T fluid level with engine idling.

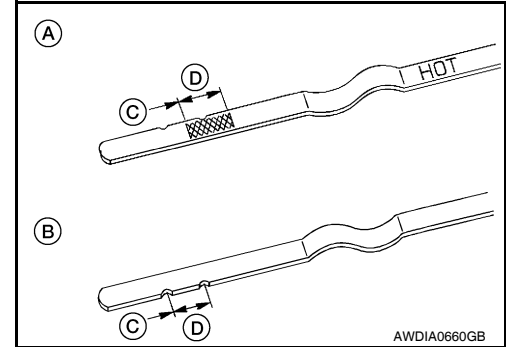

- d. Remove A/T fluid level gauge and wipe clean with lint-free cloth.
CAUTION:
When wiping the A/T fluid level gauge, always use lint-free cloth.

- e. Re-insert A/T fluid level gauge into A/T fluid charging pipe as far as it will go.

CAUTION:
Firmly fix the A/T fluid level gauge to the A/T fluid charging pipe using the stopper attached.

- f. Remove A/T fluid level gauge and note reading. If reading is at low side of range, add A/T fluid to the A/T fluid charging pipe.

CAUTION:
Do not overfill.

4. Drive vehicle for approximately 5 minutes.
5. Re-check A/T fluid level at A/T fluid temperatures of 50° to 80°C (122° to 176°F) using "HOT" range on A/T fluid level gauge.

CAUTION:

- **When wiping the A/T fluid level gauge, always use lint-free cloth.**
- **Firmly fix the A/T fluid level gauge to the A/T fluid charging pipe using the stopper attached.**

6. Check A/T fluid condition and make any necessary repairs. Refer to [AT-51, "Inspections Before Trouble Diagnosis"](#). If the A/T fluid contains frictional material (clutches, bands, etc.), or if the A/T is repaired, overhauled, or replaced, inspect and clean the A/T fluid cooler mounted in the radiator. Refer to [AT-18, "A/T Fluid Cooler Cleaning"](#).

7. Install the removed A/T fluid level gauge into the A/T fluid charging pipe.

CAUTION:
Firmly fix the A/T fluid level gauge to the A/T fluid charging pipe using the stopper attached.

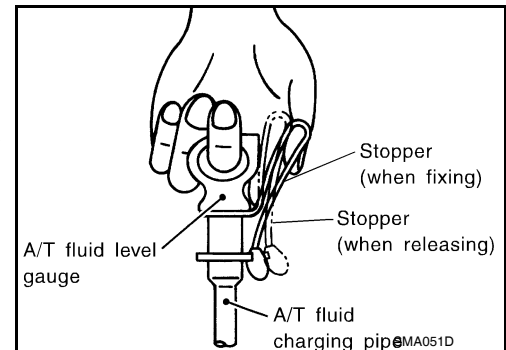

Changing A/T Fluid

INFOID:000000005928071

1. Warm up A/T fluid.
2. Stop engine.
3. Drain A/T fluid by removing the drain plug. Reinstall the drain plug to the specified torque.

CAUTION:
Do not reuse drain plug gasket.

Drain plug: Refer to [AT-237, "Component"](#).

4. Refill the transaxle with new specified A/T fluid through the A/T fluid charging pipe. Always refill the transaxle with the same volume of A/T fluid that was drained out.

A/T FLUID

< SERVICE INFORMATION >

Fluid grade and capacity: Refer to [MA-14](#).

5. Run engine at idle speed for 5 minutes.
6. Check A/T fluid level and condition. Refer to [AT-17, "Checking A/T Fluid"](#).

A/T Fluid Cooler Cleaning

INFOID:000000005928072

Whenever the A/T is repaired, overhauled, or replaced, the A/T fluid cooler mounted in the radiator must be inspected and cleaned.

Metal debris and friction material, if present, can become trapped in the A/T fluid cooler. This debris can contaminate the newly serviced A/T or, in severe cases, can block or restrict the flow of A/T fluid. In either case, malfunction of the newly serviced A/T may result.

Debris, if present, may build up as A/T fluid enters the cooler inlet. It will be necessary to back flush the cooler through the cooler outlet in order to flush out any built up debris.

A/T FLUID COOLER CLEANING PROCEDURE

1. Identify the A/T inlet and outlet fluid cooler hoses.
2. Position an oil pan under the A/T inlet and outlet fluid cooler hoses.
3. Disconnect the A/T fluid cooler inlet and outlet rubber hoses from the steel cooler tubes or bypass valve.

NOTE:

Replace the cooler hoses if rubber material from the hose remains on the tube fitting.

4. Allow any A/T fluid that remains in the cooler hoses to drain into the oil pan.

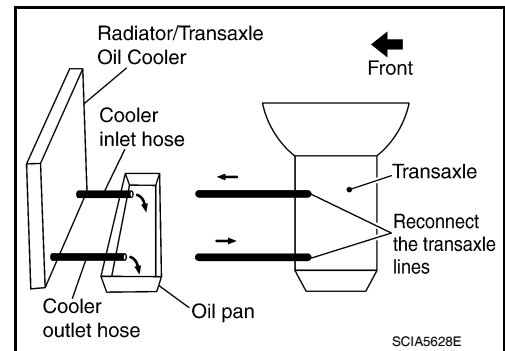

5. Insert the extension adapter hose of a can of Transmission Cooler Cleaner (Nissan P/N 999MP-AM006) into the cooler outlet hose.

CAUTION:

- **Wear safety glasses and rubber gloves when spraying the Transmission Cooler Cleaner.**
- **Spray Transmission Cooler Cleaner only with adequate ventilation.**
- **Avoid contact with eyes and skin.**
- **Do not breathe vapors or spray mist.**

6. Hold the hose and can as high as possible and spray Transmission Cooler Cleaner in a continuous stream into the cooler outlet hose until A/T fluid flows out of the cooler inlet hose for 5 seconds.

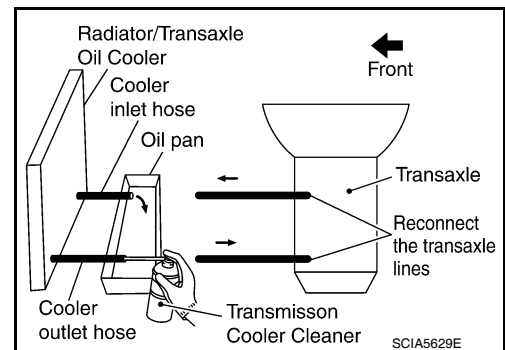

7. Insert the tip of an air gun into the end of the cooler outlet hose.
8. Wrap a shop rag around the air gun tip and end of cooler outlet hose.

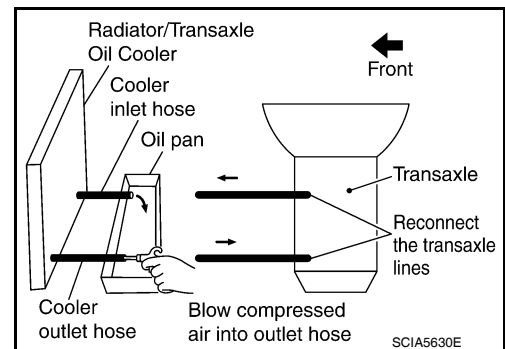

9. Blow compressed air regulated to 5 - 9 kg/cm² (490 - 883 kPa, 71 - 128 psi) through the cooler outlet hose for 10 seconds to force out any remaining A/T fluid.
10. Repeat steps 5 through 9 three additional times.
11. Position an oil pan under the banjo bolts that connect the A/T fluid cooler steel lines to the A/T.
12. Remove the banjo bolts.

A/T FLUID

< SERVICE INFORMATION >

13. Flush each steel line from the cooler side back toward the A/T by spraying Transmission Cooler Cleaner in a continuous stream for 5 seconds.
14. Blow compressed air regulated to 5 - 9 kg/cm² (490 - 883 kPa, 71 - 128 psi) through each steel line from the cooler side back toward the A/T for 10 seconds to force out any remaining A/T fluid.
15. Ensure all debris is removed from the steel cooler lines.
16. Ensure all debris is removed from the banjo bolts and fittings.
17. Perform "A/T FLUID COOLER DIAGNOSIS PROCEDURE".

A/T FLUID COOLER DIAGNOSIS PROCEDURE

NOTE:

Insufficient cleaning of the cooler inlet hose exterior may lead to inaccurate debris identification.

1. Position an oil pan under the A/T inlet and outlet cooler hoses.
2. Clean the exterior and tip of the cooler inlet hose.
3. Insert the extension adapter hose of a can of Transmission Cooler Cleaner (Nissan P/N 999MP-AM006) into the cooler outlet hose.

CAUTION:

- Wear safety glasses and rubber gloves when spraying the Transmission Cooler Cleaner.
- Spray Transmission Cooler Cleaner only with adequate ventilation.
- Avoid contact with eyes and skin.
- Do not breathe vapors or spray mist.

4. Hold the hose and can as high as possible and spray Transmission Cooler Cleaner in a continuous stream into the cooler outlet hose until A/T fluid flows out of the cooler inlet hose for 5 seconds.
5. Tie a common white, basket-type coffee filter to the end of the cooler inlet hose.

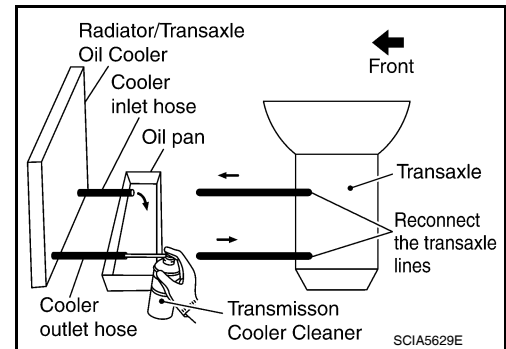

6. Insert the tip of an air gun into the end of the cooler outlet hose.
7. Wrap a shop rag around the air gun tip and end of cooler outlet hose.
8. Blow compressed air regulated to 5 - 9 kg/cm² (490 - 883 kPa, 71 - 128 psi) through the cooler outlet hose to force any remaining A/T fluid into the coffee filter.
9. Remove the coffee filter from the end of the cooler inlet hose.
10. Perform "A/T FLUID COOLER INSPECTION PROCEDURE".

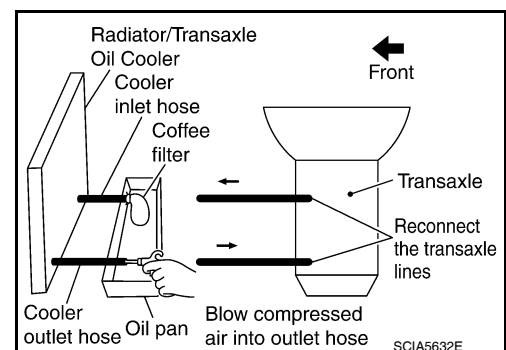
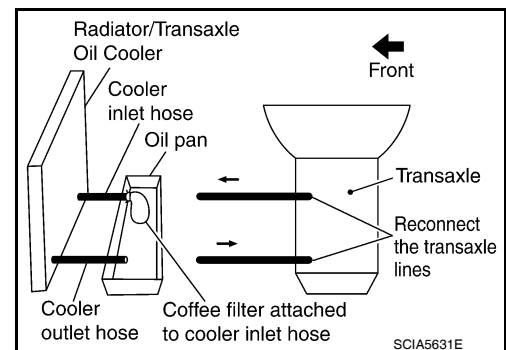

A/T FLUID COOLER INSPECTION PROCEDURE

A/T FLUID

< SERVICE INFORMATION >

1. Inspect the coffee filter for debris.
 - a. If small metal debris less than 1mm (0.040 in) in size or metal powder is found in the coffee filter, this is normal. If normal debris is found, the A/T fluid cooler/radiator can be re-used and the procedure is ended.
 - b. If one or more pieces of debris are found that are over 1mm (0.040 in) in size and/or peeled clutch facing material is found in the coffee filter, the A/T fluid cooler is not serviceable. The A/T fluid cooler/radiator must be replaced and the inspection procedure is ended. Refer to [CO-40, "Component"](#).

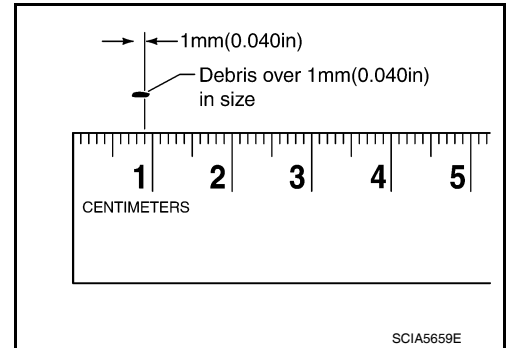
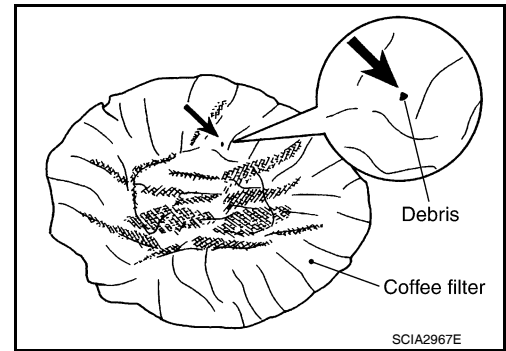

A/T FLUID COOLER FINAL INSPECTION

After performing all procedures, ensure that all remaining oil is cleaned from all components.

A/T CONTROL SYSTEM

< SERVICE INFORMATION >

A/T CONTROL SYSTEM

Cross-Sectional View

INFOID:000000005928073

HR16DE engine models

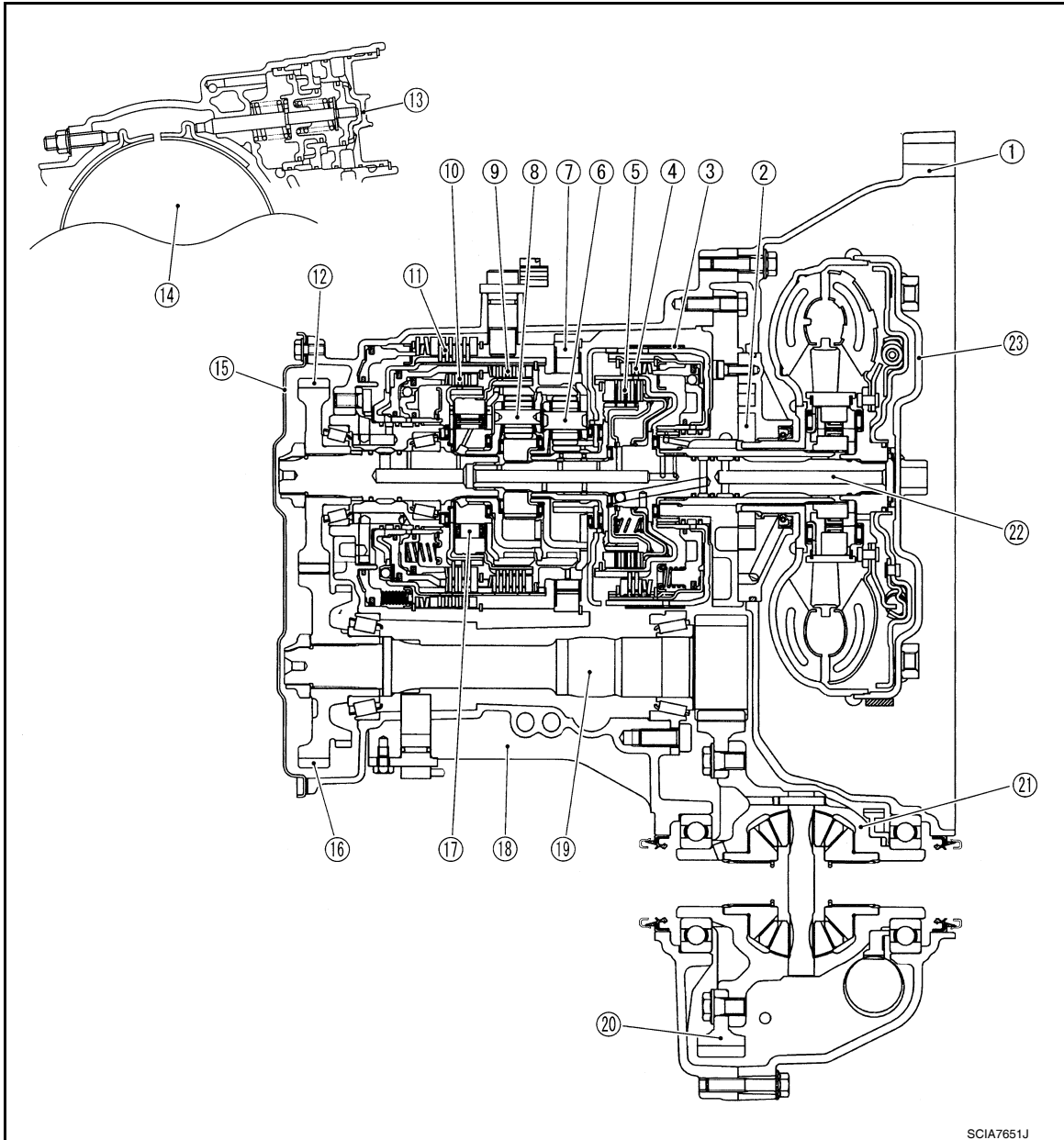

SCIA7651J

- | | | |
|---------------------------|----------------------------|-------------------------|
| 1. Converter housing | 2. Oil pump | 3. Brake band |
| 4. Reverse clutch | 5. High clutch | 6. Front planetary gear |
| 7. Low one-way clutch | 8. Rear planetary gear | 9. Forward clutch |
| 10. Overrun clutch | 11. Low & reverse brake | 12. Output gear |
| 13. Band servo piston | 14. Reverse clutch drum | 15. Side cover |
| 16. Idler gear | 17. Forward one-way clutch | 18. Transaxle case |
| 19. Reduction pinion gear | 20. Final gear | 21. Differential case |
| 22. Input shaft | 23. Torque converter | |

A
B
AT
D
E
F
G
H
I
J
K
L
M
N
O
P

A/T CONTROL SYSTEM

< SERVICE INFORMATION >

MR18DE engine models

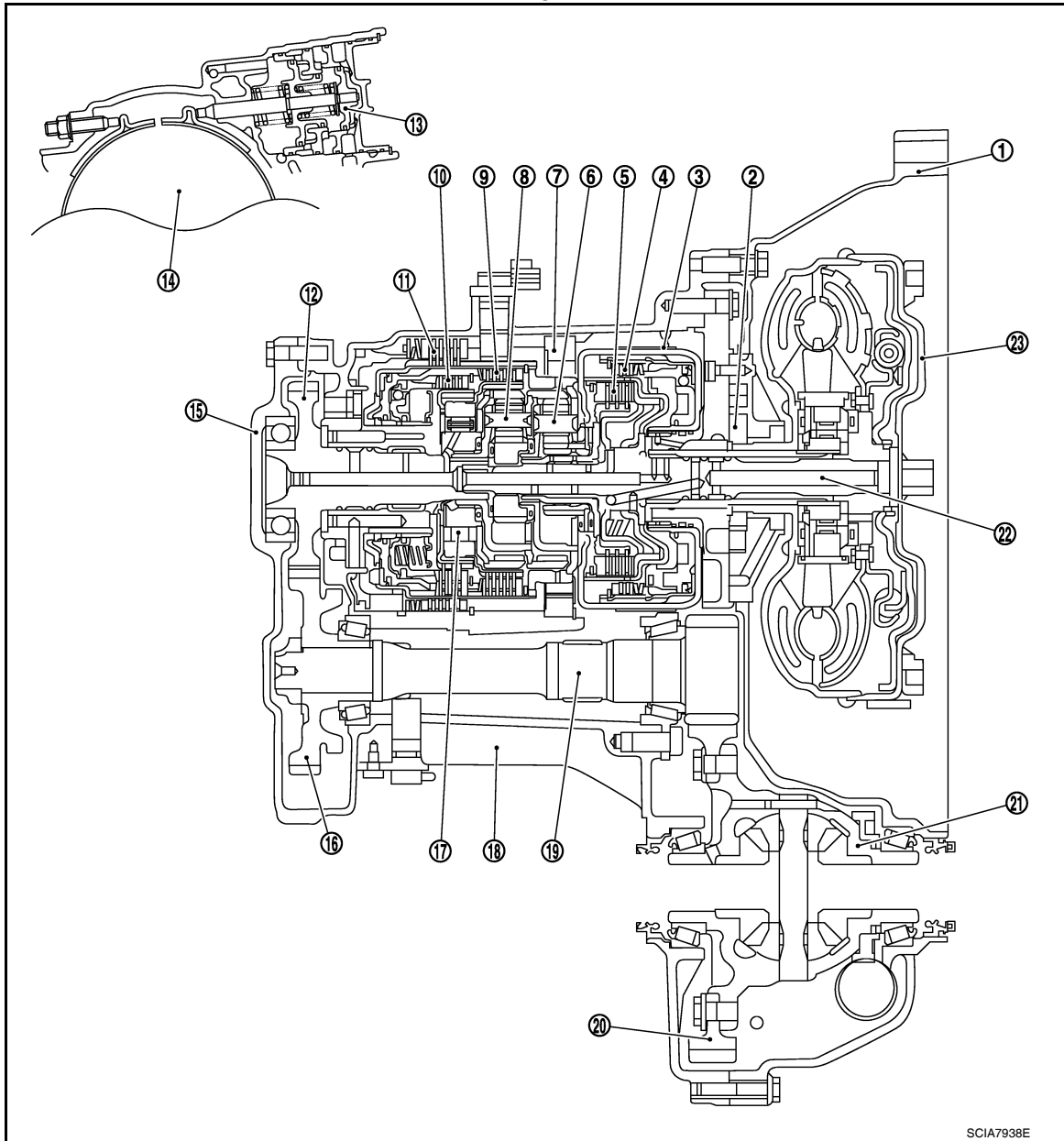

- | | | |
|---------------------------|----------------------------|-------------------------|
| 1. Converter housing | 2. Oil pump | 3. Brake band |
| 4. Reverse clutch | 5. High clutch | 6. Front planetary gear |
| 7. Low one-way clutch | 8. Rear planetary gear | 9. Forward clutch |
| 10. Overrun clutch | 11. Low & reverse brake | 12. Output gear |
| 13. Band servo piston | 14. Reverse clutch drum | 15. Side cover |
| 16. Idler gear | 17. Forward one-way clutch | 18. Transaxle case |
| 19. Reduction pinion gear | 20. Final gear | 21. Differential case |
| 22. Input shaft | 23. Torque converter | |

Shift Mechanism

INFOID:000000005928074

CONSTRUCTION

A/T CONTROL SYSTEM

< SERVICE INFORMATION >

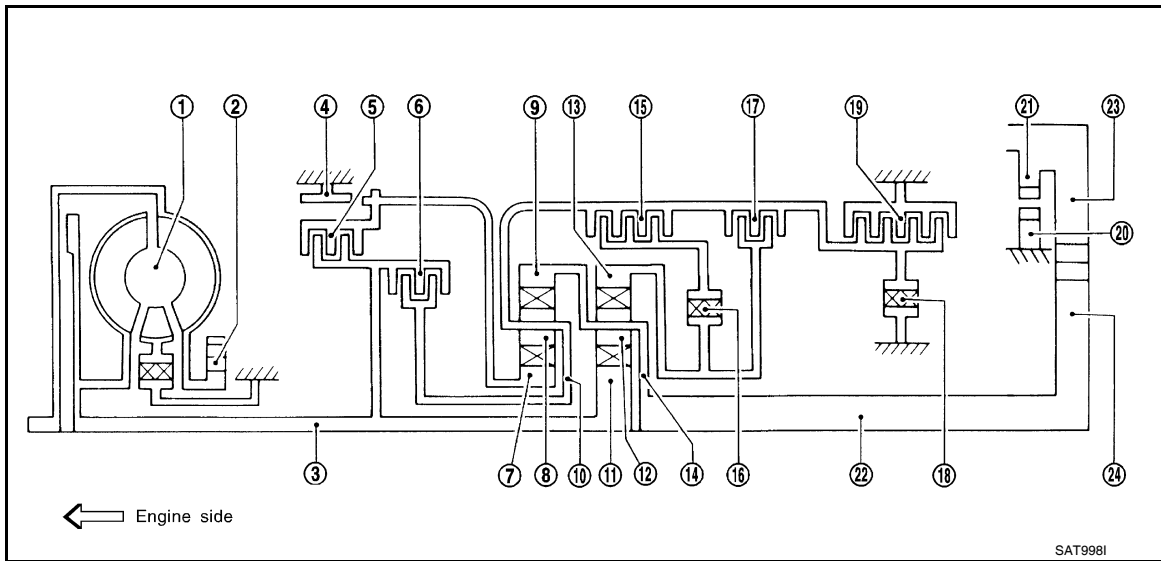

- | | | |
|-----------------------------|----------------------------|------------------------|
| 1. Torque converter | 2. Oil pump | 3. Input shaft |
| 4. Brake band | 5. Reverse clutch | 6. High clutch |
| 7. Front sun gear | 8. Front pinion gear | 9. Front internal gear |
| 10. Front planetary carrier | 11. Rear sun gear | 12. Rear pinion gear |
| 13. Rear internal gear | 14. Rear planetary carrier | 15. Forward clutch |
| 16. Forward one-way clutch | 17. Overrun clutch | 18. Low one-way clutch |
| 19. Low & reverse brake | 20. Parking pawl | 21. Parking gear |
| 22. Output shaft | 23. Idle gear | 24. Output gear |

FUNCTION OF CLUTCH AND BRAKE

Clutch and brake components	Abbr.	Function
5 Reverse clutch	R/C	To transmit input power to front sun gear 7.
6 High clutch	H/C	To transmit input power to front planetary carrier 10.
15 Forward clutch	F/C	To connect front planetary carrier 10 with forward one-way clutch 16.
17 Overrun clutch	O/C	To connect front planetary carrier 10 with rear internal gear 13.
4 Brake band	B/B	To lock front sun gear 7.
16 Forward one-way clutch	F/O.C	When forward clutch 15 is engaged, to stop rear internal gear 13 from rotating in opposite direction against engine revolution.
18 Low one-way clutch	L/O.C	To stop front planetary carrier 10 from rotating in opposite direction against engine revolution.
19 Low & reverse brake	L & R/B	To lock front planetary carrier 10.

CLUTCH AND BAND CHART

Shift position	R/C 5	H/C 6	F/C 15	O/C 17	Band servo			F/O.C 16	L/O.C 18	L&R/B 19	Lock-up	Remarks
					2nd apply	3rd re-release	4th apply					
P												PARK POSITION
R	○									○		REVERSE POSITION
N												NEUTRAL POSITION
D*4	1st		○	*1D				B	B			

A/T CONTROL SYSTEM

< SERVICE INFORMATION >

Shift position	R/C 5	H/C 6	F/C 15	O/C 17	Band servo			F/O.C 16	L/O.C 18	L&R/B 19	Lock-up	Remarks
					2nd apply	3rd re-lease	4th ap- ply					
2nd			○	*1A	○			B				Automatic shift
3rd		○	○	*1A	*2C	C		B			*1○	1 ⇄ 2 ⇄ 3 ⇄ 4
4th		○	C		*3C	C	○				○	
2	1st		○	○				B	B			Automatic shift
	2nd		○	○	○			B				1 ⇄ 2 ⇄ 3
	3rd		○	○	○	*2C	C	B				
1	1st		○	○				B	B	○		Locks (held stationary) in 1st speed
	2nd		○	○	○			B				1 ⇄ 2 ⇄ 3
	3rd		○	○	○	*2C	C	B				

- *1: Operates when OD OFF. (OD OFF indicator lamp is on.)
- *2: Oil pressure is applied to both 2nd “apply” side and 3rd “release” side of band servo piston. However, brake band does not contract because oil pressure area on the “release” side is greater than that on the “apply” side.
- *3: Oil pressure is applied to 4th “apply” side on condition *2 above, and brake band contracts.
- *4: A/T will not shift to 4th when OD OFF. (OD OFF indicator lamp is on.)
- : Operates.
- A: Operates when throttle opening is less than specification**, activating engine brake.
- B: Operates during “progressive” acceleration.
- C: Operates but does not affect power transmission.
- D: Operates when throttle opening is less than specification**, but does not affect engine brake.
- **: Overrun clutch remains in engaged condition when throttle opening is less than 1/16.

POWER TRANSMISSION

“N” and “P” Positions

- “N” position
Power from the input shaft is not transmitted to the output shaft because the clutches do not operate.
- “P” position
Similar to the “N” position, the clutches do not operate. The parking pawl engages with the parking gear to mechanically hold the output shaft so that the power train is locked.

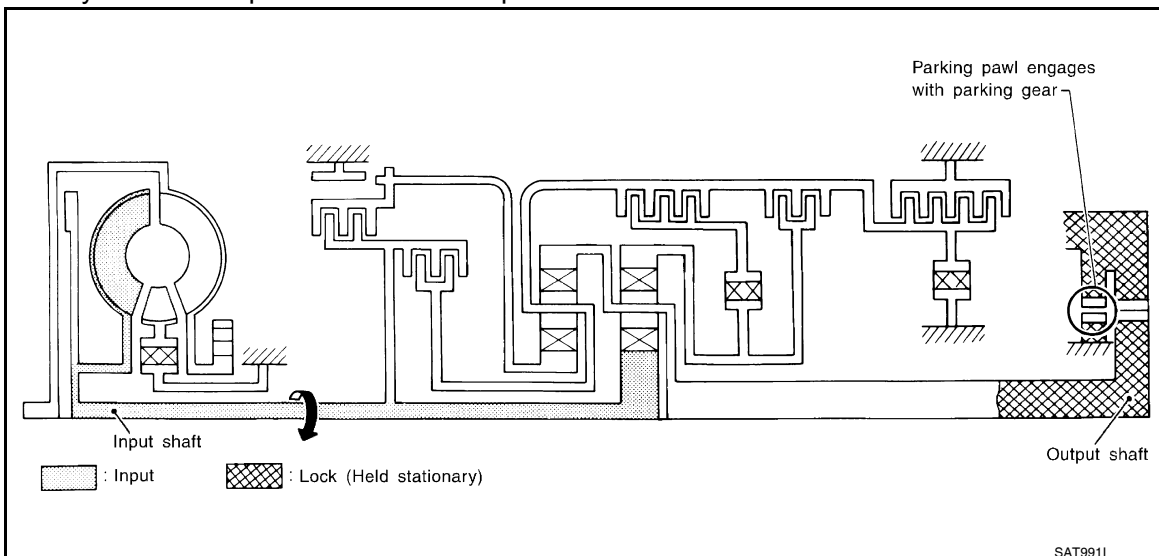

“1” Position

A/T CONTROL SYSTEM

< SERVICE INFORMATION >

<ul style="list-style-type: none"> • Forward clutch • Forward one-way clutch • Overrun clutch • Low & reverse brake 	<p>As overrun clutch engages, rear internal gear is locked by the operation of low and reverse brake. This is different from that of D1 and 21.</p>
<p>Engine brake</p>	<p>Overrun clutch always engages, therefore engine brake can be obtained when decelerating.</p>

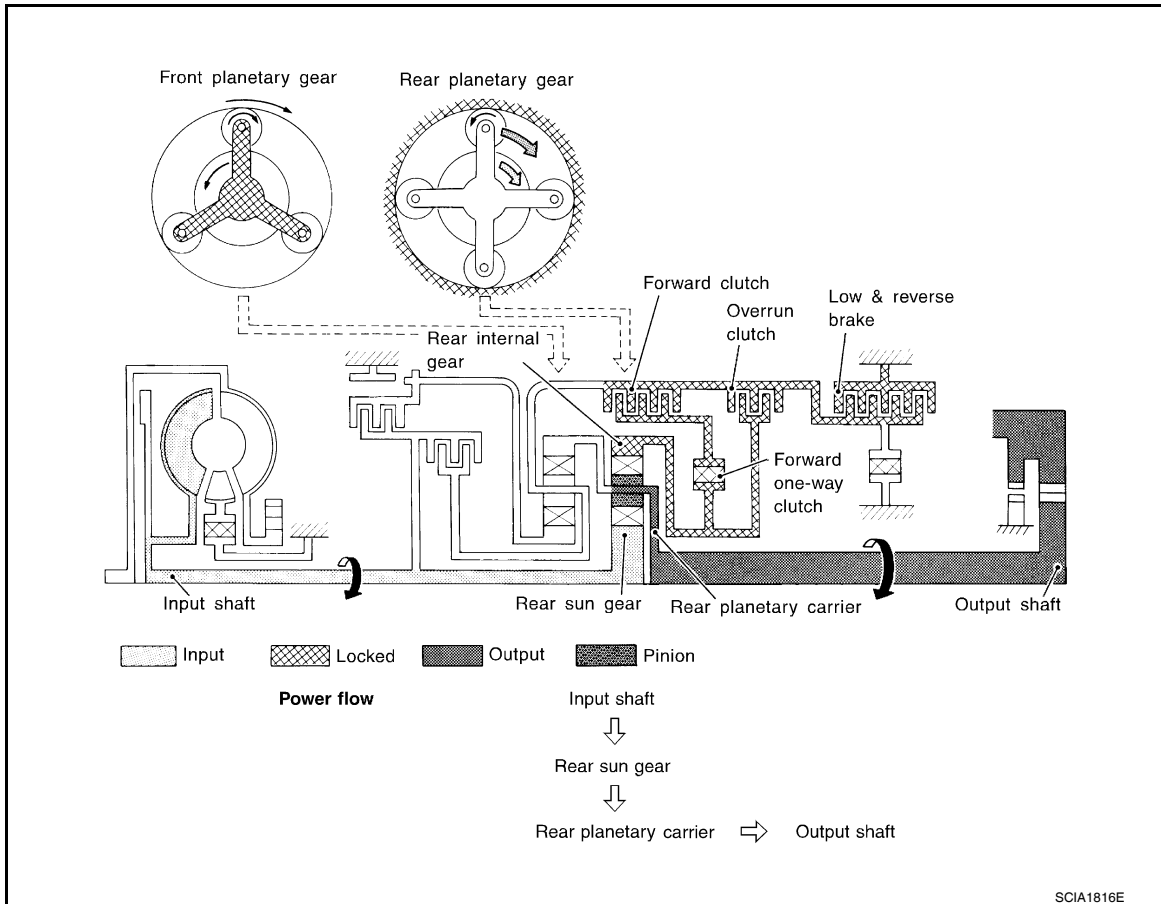

“D1” and “21” Positions

<ul style="list-style-type: none"> • Forward one-way clutch • Forward clutch • Low one-way clutch 	<p>Rear internal gear is locked to rotate counterclockwise because of the functioning of these three clutches.</p>
<p>Overrun clutch engagement conditions (Engine brake)</p>	<p>D1: OD OFF (OD OFF indicator lamp is on) and throttle opening is less than specification* 21: Always engaged At D1 and 21 positions, engine brake is not activated due to free turning of low one-way clutch.</p>

*: Overrun clutch remains in engaged condition when throttle opening is less than 1/16.

A/T CONTROL SYSTEM

< SERVICE INFORMATION >

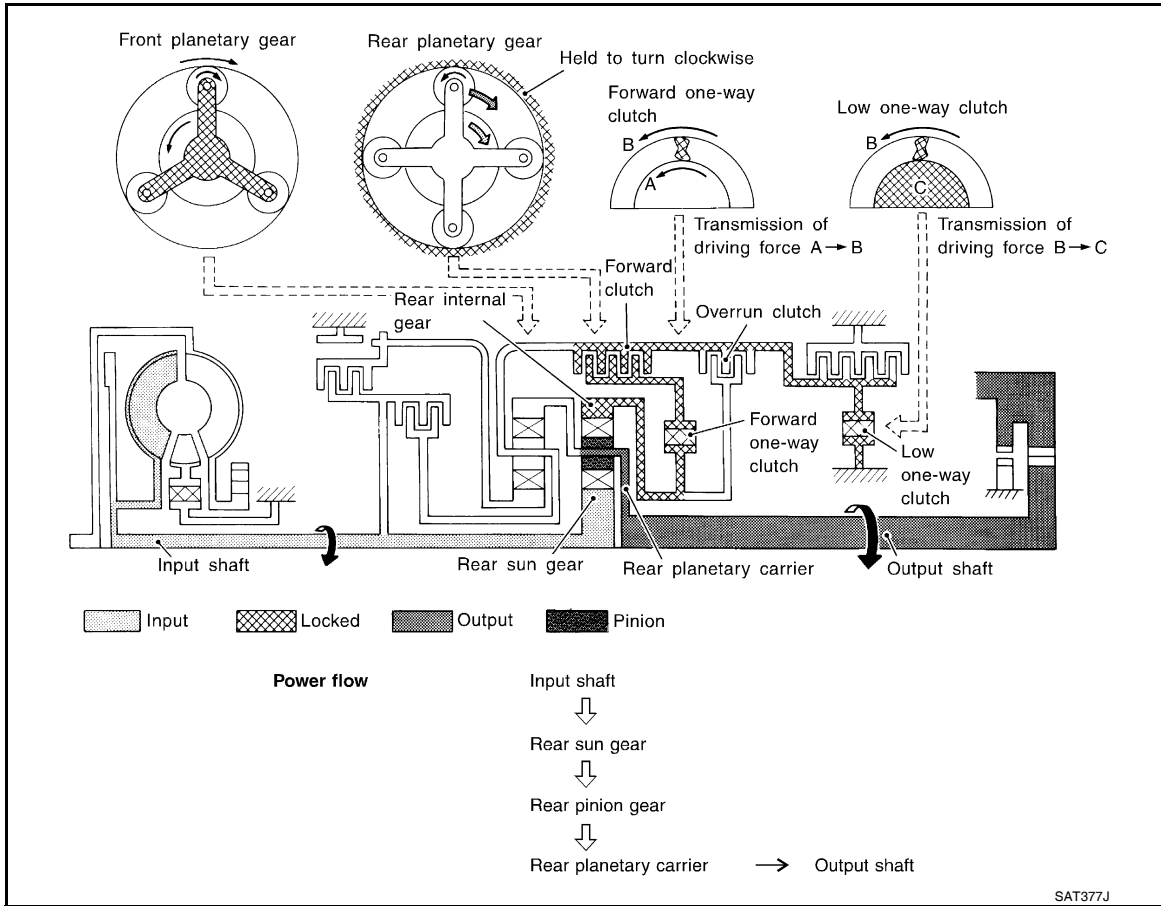

“D2”, “22” and “12” Positions

<ul style="list-style-type: none"> • Forward clutch • Forward one-way clutch • Brake band 	Rear sun gear drives rear planetary carrier and combined front internal gear. Front internal gear now rotates around front sun gear accompanying front planetary carrier. As front planetary carrier transfers the power to rear internal gear through forward clutch and forward one-way clutch, this rotation of rear internal gear increases the speed of rear planetary carrier compared with that of the 1st speed.
Overrun clutch engagement conditions	D2: OD OFF (OD OFF indicator lamp is on) and throttle opening is less than specification* 22 and 12: Always engaged

*: Overrun clutch remains in engaged condition when throttle opening is less than 1/16.

A/T CONTROL SYSTEM

< SERVICE INFORMATION >

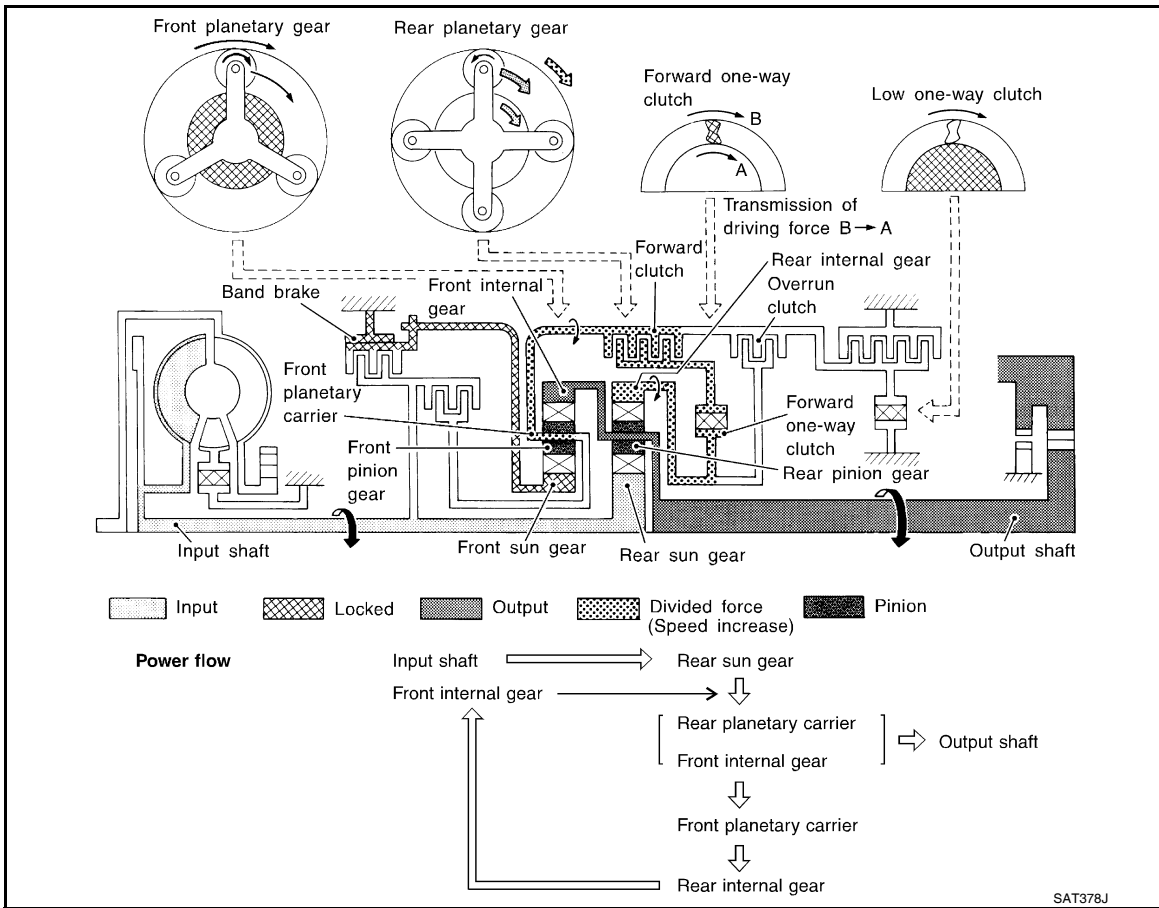

"D3", "23" and "13" Positions

<ul style="list-style-type: none"> • High clutch • Forward clutch • Forward one-way clutch 	<p>Input power is transmitted to front planetary carrier through high clutch. And front planetary carrier is connected to rear internal gear by operation of forward clutch and forward one-way clutch.</p> <p>This rear internal gear rotation and another input (the rear sun gear) accompany rear planetary carrier to turn at the same speed.</p>
<p>Overrun clutch engagement conditions</p>	<p>D3: OD OFF (OD OFF indicator lamp is on) and throttle opening is less than specification*</p> <p>23 and 13: Always engaged</p>

*: Overrun clutch remains in engaged condition when throttle opening is less than 1/16.

A/T CONTROL SYSTEM

< SERVICE INFORMATION >

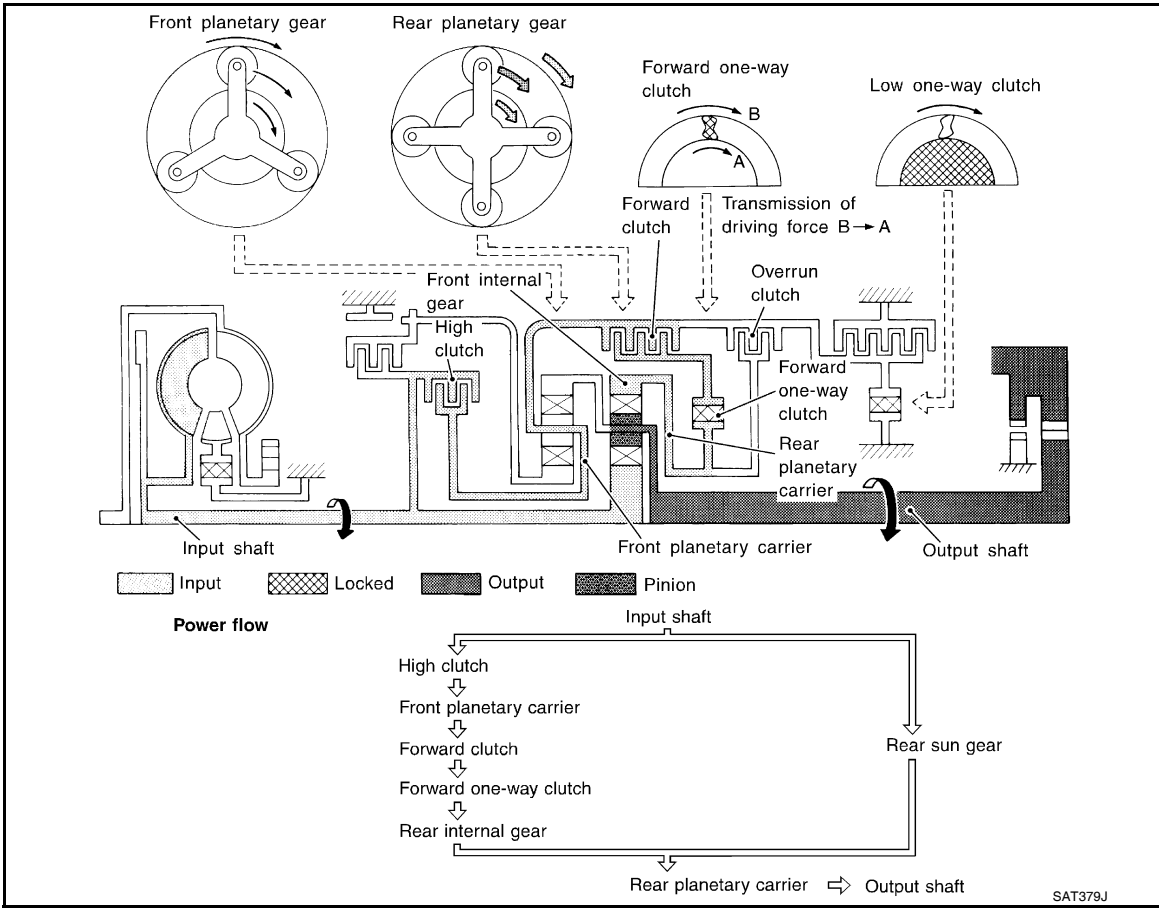

"D4" (OD) Position

<ul style="list-style-type: none"> • High clutch • Brake band • Forward clutch (Does not affect power transmission) 	<p>Input power is transmitted to front carrier through high clutch. This front carrier turns around the sun gear which is fixed by brake band and makes front internal gear (output) turn faster.</p>
<p>Engine brake</p>	<p>At D4 position, there is no one-way clutch in the power transaxle line and engine brake can be obtained when decelerating.</p>

A/T CONTROL SYSTEM

< SERVICE INFORMATION >

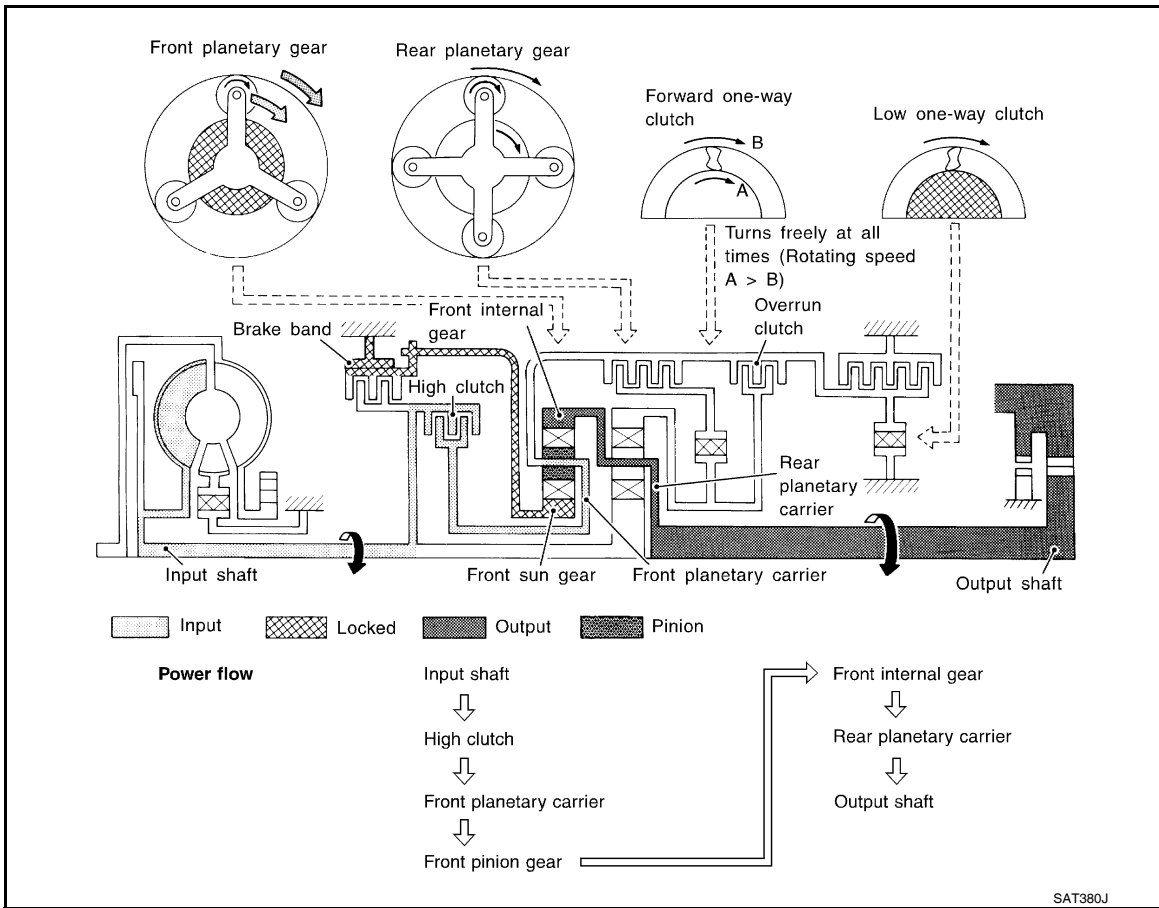

“R” Position

<ul style="list-style-type: none"> • Reverse clutch • Low & reverse brake 	<p>Front planetary carrier is stationary because of the operation of low and reverse brake. Input power is transmitted to front sun gear through reverse clutch, which drives front internal gear in the opposite direction.</p>
<p>Engine brake</p>	<p>As there is no one-way clutch in the power transaxle line, engine brake can be obtained when decelerating.</p>

A/T CONTROL SYSTEM

< SERVICE INFORMATION >

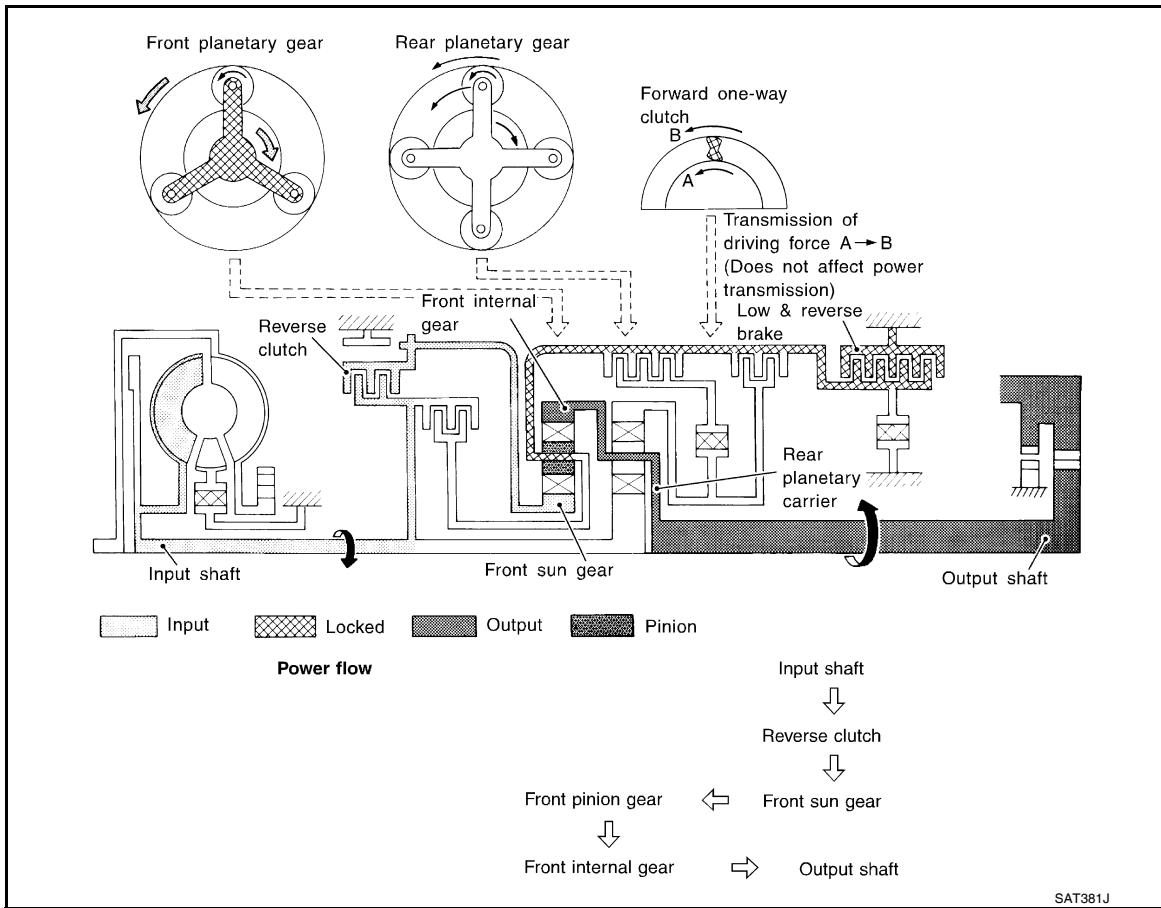

TCM Function

INFOID:000000005928075

The function of the TCM is to:

- Receive input signals sent from various switches and sensors.
- Determine required line pressure, shifting point, lock-up operation, and engine brake operation.
- Send required output signals to the respective solenoids.

CONTROL SYSTEM OUTLINE

The automatic transaxle senses vehicle operating conditions through various sensors or signals. It always controls the optimum shift position and reduces shifting and lock-up shocks.

SWITCHES & SENSORS		TCM		ACTUATORS
Transmission range switch Accelerator pedal position signal Closed throttle position signal Wide open throttle position signal Engine speed signal A/T fluid temperature sensor Output speed sensor Input speed sensor Vehicle speed signal Overdrive control switch signal Stop lamp switch signal	⇒	Shift control Line pressure control Lock-up control Overrun clutch control Fail-safe control Self-diagnosis CONSULT-III communication line control	⇒	Shift solenoid valve A Shift solenoid valve B Overrun clutch solenoid valve Torque converter clutch solenoid valve Line pressure solenoid valve OD OFF indicator lamp

A/T CONTROL SYSTEM

< SERVICE INFORMATION >

CONTROL SYSTEM DIAGRAM

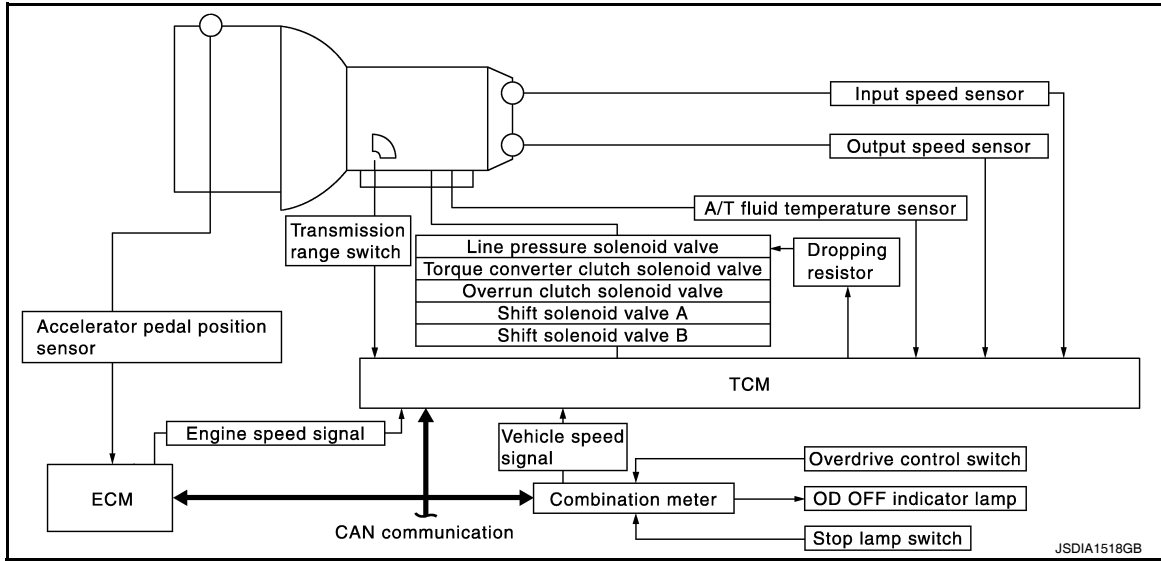

CAN Communication

INFOID:000000005928076

SYSTEM DESCRIPTION

CAN (Controller Area Network) is a serial communication line for real time application. It is an on-vehicle multiplex communication line with high data communication speed and excellent error detection ability. Many electronic control units are equipped onto a vehicle, and each control unit shares information and links with other control units during operation (not independent). In CAN communication, control units are connected with 2 communication lines (CAN H line, CAN L line) allowing a high rate of information transmission with less wiring. Each control unit transmits/receives data but selectively reads required data only. For details, refer to [LAN-7, "System Description"](#).

Input/Output Signal of TCM

INFOID:000000005928077

Control item		Line pressure control	Vehicle speed control	Shift control	Lock-up control	Engine brake control	Fail-safe function	Self-diagnostics function
Input	Accelerator pedal position signal ^(*5)	X	X	X	X	X	(*3) X	X
	Output speed sensor	X	X	X	X	X	(*3) X	X
	Vehicle speed signal	(*1) X	(*1) X	(*1) X	(*1) X			X
	Closed throttle position signal ^(*5)	(*2) X	(*2) X		X	X		(*4) X
	Wide open throttle position signal ^(*5)	(*2) X	(*2) X					(*4) X
	Input speed sensor	X	X		X		X	X
	Engine speed signal		X		X		X	X
	Transmission range switch	X	X	X	X	X	(*3) X	(*4) X
	Stop lamp switch signal ^(*5)		X		X			(*4) X
	A/T fluid temperature sensors ^(*5)	X	X	X	X		X	X
	Overdrive control switch signal ^(*5)		X	X	X	X		(*4) X
	TCM power supply voltage signal	X			X		X	X

A/T CONTROL SYSTEM

< SERVICE INFORMATION >

Control item		Line pressure control	Vehicle speed control	Shift control	Lock-up control	Engine brake control	Fail-safe function	Self-diagnos- tics function
Out- put	Shift solenoid valve A/B		X				(*3) X	X
	Line pressure solenoid	X					(*3) X	X
	Torque converter clutch solenoid valve				X		(*3) X	X
	Overrun clutch solenoid valve		X			X	(*3) X	X
	OD OFF indicator lamp ^(*6)		X					X

*1: Output speed sensor

*2: Spare for accelerator pedal position signal

*3: If these input and output signals are different, the TCM triggers the fail-safe function.

*4: Used as a condition for starting self-diagnostics; if self-diagnosis are not started, it is judged that there is some kind of error.

*5: Input by CAN communications.

*6: Output by CAN communications.

Line Pressure Control

INFOID:000000005928078

- TCM has various line pressure control characteristics to match the driving conditions.
- An ON-OFF duty signal is sent to the line pressure solenoid valve based on TCM characteristics.
- Hydraulic pressure on the clutch and brake is electronically controlled through the line pressure solenoid valve to accommodate engine torque. This results in smooth shift operation.

NORMAL CONTROL

The characteristic of the line pressure to the throttle opening is set for suitable clutch operation.

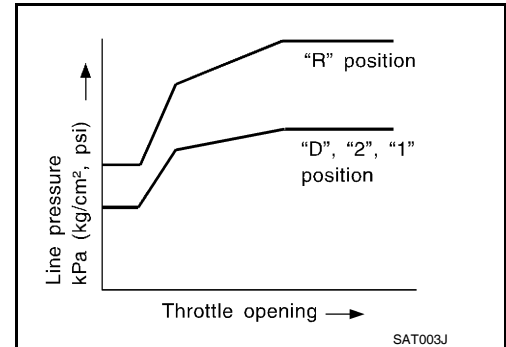

BACK-UP CONTROL (ENGINE BRAKE)

If the selector lever is shifted to "2" position while driving in D4 or D3, great driving force is applied to the clutch inside the transaxle. Clutch operating pressure (line pressure) must be increased to deal with this driving force.

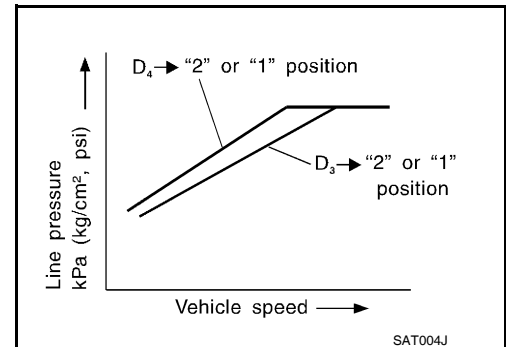

DURING SHIFT CHANGE

A/T CONTROL SYSTEM

< SERVICE INFORMATION >

The line pressure is temporarily reduced corresponding to a change in engine torque when shifting gears (that is, when the shift solenoid valve is switched for clutch operation) to reduce shifting shock.

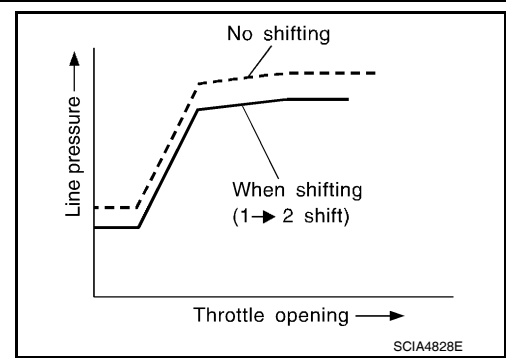

AT LOW FLUID TEMPERATURE

- A/T fluid viscosity and frictional characteristics of the clutch facing change with A/T fluid temperature. Clutch engaging or band-contacting pressure is compensated for, according to A/T fluid temperature, to stabilize shifting quality.
- The line pressure is reduced below 60°C (140°F) to prevent shifting shock due to high viscosity of A/T fluid when temperature is low.

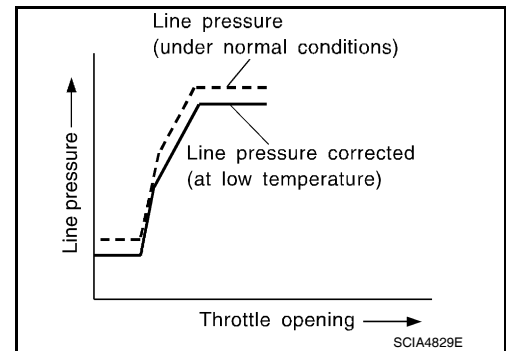

- Line pressure is increased to a maximum irrespective of the throttle opening when A/T fluid temperature drops to -10°C (14°F). This pressure rise is adopted to prevent a delay in clutch and brake operation due to extreme drop of A/T fluid viscosity at low temperature.

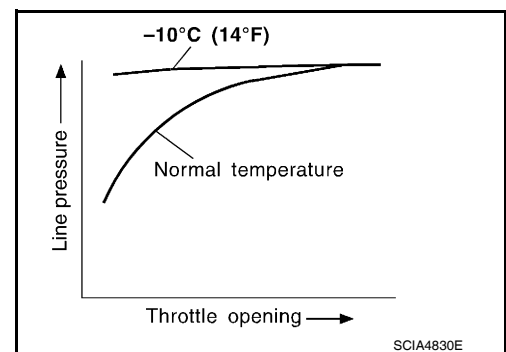

Shift Control

INFOID:000000005928079

The shift is regulated entirely by electronic control to accommodate vehicle speed and varying engine operations. This is accomplished by electrical signals transmitted by the output speed sensor and the ECM (accelerator pedal position sensor). This results in improved acceleration performance and fuel economy.

CONTROL OF SHIFT SOLENOID VALVES A AND B

The TCM activates shift solenoid valves A and B according to signals from the accelerator pedal position sensor and output speed sensor to select the optimum gear position on the basis of the shift schedule memorized in the TCM.

The shift solenoid valve performs simple ON-OFF operation. When set to "ON", the drain circuit closes and pilot pressure is applied to the shift valve.

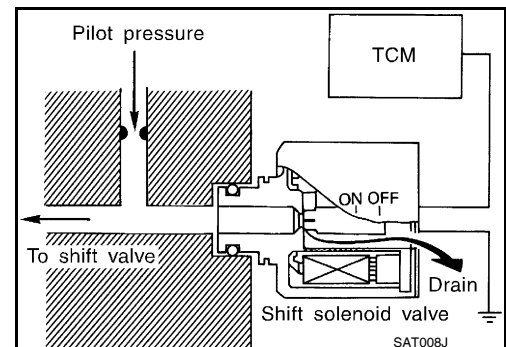

RELATION BETWEEN SHIFT SOLENOID VALVES A AND B AND GEAR POSITIONS

A/T CONTROL SYSTEM

< SERVICE INFORMATION >

Gear position	1	2	3	4
Shift solenoid valve A	ON (Closed)	OFF (Open)	OFF (Open)	ON (Closed)
Shift solenoid valve B	ON (Closed)	ON (Closed)	OFF (Open)	OFF (Open)

CONTROL OF SHIFT VALVES A AND B

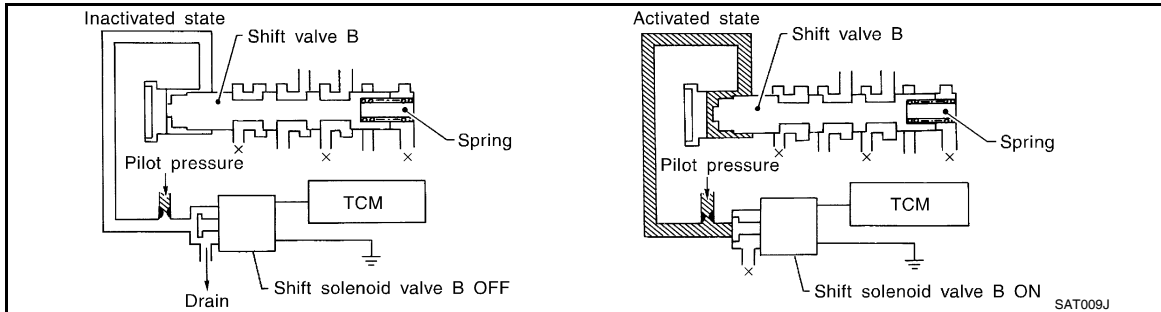

Pilot pressure generated by the operation of shift solenoid valves A and B is applied to the end face of shift valves A and B.

The figure above shows the operation of shift valve B. When the shift solenoid valve is "ON", pilot pressure applied to the end face of the shift valve overcomes spring force, moving the valve upward.

Lock-up Control

INFOID:000000005928080

The torque converter clutch piston in the torque converter is locked to eliminate torque converter slip and to increase power transmission efficiency. The solenoid valve is controlled by an ON-OFF duty signal sent from the TCM. The signal is converted to an oil pressure signal which controls the torque converter clutch piston.

CONDITIONS FOR LOCK-UP OPERATION

When vehicle is driven in 3GR and 4GR positions, vehicle speed and throttle opening are detected. If the detected values fall within the lock-up zone memorized in the TCM, lock-up is performed.

OD	ON	OFF
Selector lever	"D" position	
Gear position	D4	D3
Vehicle speed signal	More than set value	
Accelerator pedal position signal	Less than set opening	
Closed throttle position signal	OFF	
A/T fluid temperature sensor	More than 40°C (104°F)	

TORQUE CONVERTER CLUTCH SOLENOID VALVE CONTROL

A/T CONTROL SYSTEM

< SERVICE INFORMATION >

Lock-up Control System Diagram

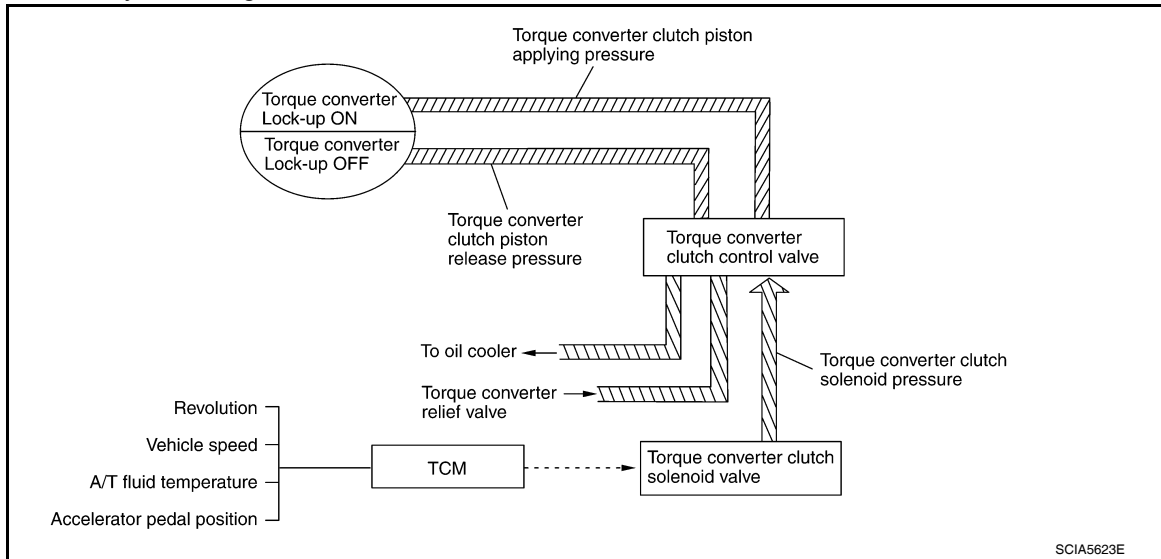

Lock-up Released

In the lock-up released state, the torque converter clutch control valve is set into the unlocked state by draining the torque converter clutch piston applying pressure and the torque converter clutch piston release pressure is generated.

In this way, the torque converter clutch piston is not coupled.

Lock-up Applied

In the lock-up applied state, the torque converter clutch control valve is set into the locked state by generating the torque converter clutch piston applying pressure and the torque converter clutch piston release pressure is drained.

In this way, the torque converter clutch piston is pressed and coupled.

SMOOTH LOCK-UP CONTROL

When shifting from the lock-up released state to the lock-up applied state, the current output to the torque converter clutch solenoid is controlled with the TCM. In this way, when shifting to the lock-up applied state, the torque converter clutch is temporarily set to the half-clutched state to reduce the shock.

Half-clutched State

The current output from the TCM to the torque converter clutch solenoid is varied to steadily increase the torque converter clutch solenoid pressure.

In this way, the lock-up applying pressure gradually rises and while the torque converter clutch piston is put into half-clutched status, the torque converter clutch piston applying pressure is increased and the coupling is completed smoothly.

Engine Brake Control (Overrun Clutch Control)

INFOID:000000005928081

Forward one-way clutch is used to reduce shifting shocks in downshifting operations. This clutch transmits engine torque to the wheels. However, drive force from the wheels is not transmitted to the engine because the one-way clutch rotates idle. This means the engine brake is not effective.

The overrun clutch operates when the engine brake is needed.

A/T CONTROL SYSTEM

< SERVICE INFORMATION >

OVERRUN CLUTCH OPERATING CONDITIONS

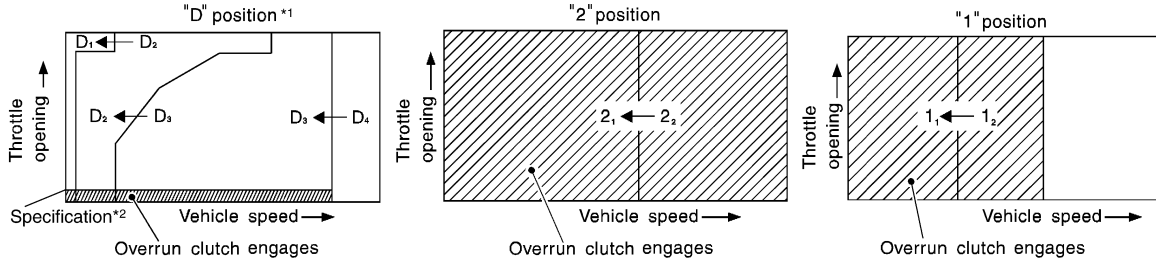

Selector lever position	Gear position	Throttle opening
"D" position *1	D ₁ , D ₂ , D ₃ gear position	Less than specification *2
"2" position	2 ₁ , 2 ₂ gear position	At any position
"1" position	1 ₁ , 1 ₂ gear position	

*1 : When OD OFF (OD OFF indicator lamp is on.)

*2 : Overrun clutch remains in engaged condition when throttle opening is less than 1/16.

SCIA7186E

OVERRUN CLUTCH SOLENOID VALVE CONTROL

The overrun clutch solenoid valve is operated by an ON-OFF signal transmitted by the TCM to provide overrun clutch control (engine brake control).

When this solenoid valve is "ON", the pilot pressure drain port closes. When it is "OFF", the drain port opens.

During the solenoid valve "ON" pilot pressure is applied to the end face of the overrun clutch control valve.

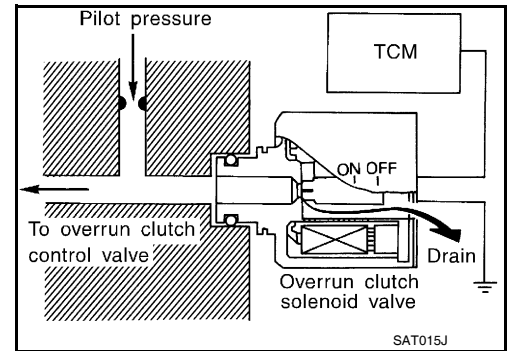

SAT015J

OVERRUN CLUTCH CONTROL VALVE OPERATION

When the solenoid valve is "ON", pilot pressure is applied to the overrun clutch control valve. This pushes up the overrun clutch control valve. The line pressure is then shut off so that the clutch does not engage. Only in "1" position, however, 1 range pressure is applied to overrun clutch control valve, resulting in valve moving downward and clutch engaged.

When the solenoid valve is "OFF", pilot pressure is not generated. At this point, the overrun clutch control valve moves downward by spring force. As a result, overrun clutch operation pressure is provided by the overrun clutch reducing valve. At overrun clutch reducing valve in "D" position, the hydraulic pressure is reduced to a level that balances the spring force. This is sent to overrun clutch control valve and becomes the operating pressure of overrun clutch which is engaged at all times. In "2" position and "1" position, overrun clutch reducing valve is pushed down by 2 range pressure. Line pressure is directly sent to overrun clutch control valve and becomes the operating pressure of overrun clutch which is engaged at all times.

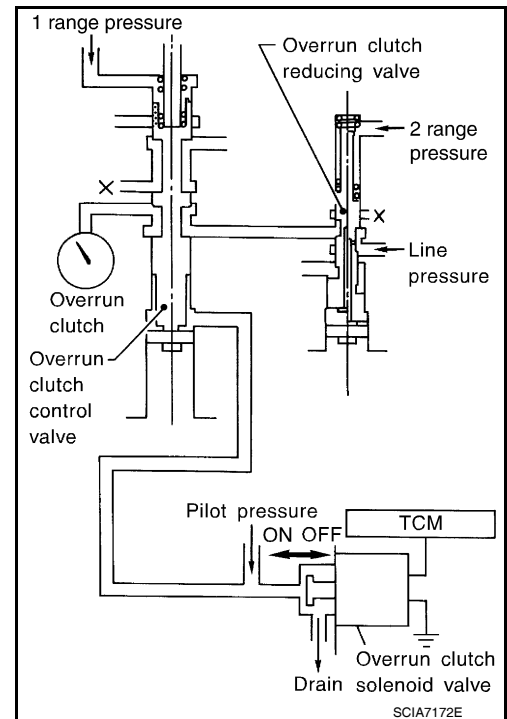

SCIA7172E

A/T CONTROL SYSTEM

< SERVICE INFORMATION >

Control Valve

INFOID:000000005928082

FUNCTION OF CONTROL VALVES

Valve name	Function
Pressure regulator valve, plug and sleeve plug	Regulates oil discharged from the oil pump to provide optimum line pressure for all driving conditions.
Pressure modifier valve and sleeve	Used as a signal supplementary valve to the pressure regulator valve. Regulates pressure-modifier pressure (signal pressure) which controls optimum line pressure for all driving conditions.
Pilot valve	Regulates line pressure to maintain a constant pilot pressure level which controls lock-up mechanism, overrun clutch, shift timing.
Accumulator control valve	Regulates accumulator back-pressure to pressure suited to driving conditions.
Manual valve	Directs line pressure to oil circuits corresponding to select positions. Hydraulic pressure drains when the shift lever is in Neutral.
Shift valve A	Simultaneously switches three oil circuits using output pressure of shift solenoid valve A to meet driving conditions (vehicle speed, throttle opening, etc.). Provides automatic downshifting and upshifting (1GR → 2GR → 3GR → 4GR/4GR → 3GR → 2GR → 1GR) in combination with shift valve B.
Shift valve B	Simultaneously switches two oil circuits using output pressure of shift solenoid valve B in relation to driving conditions (vehicle speed, throttle opening, etc.). Provides automatic downshifting and upshifting (1GR → 2GR → 3GR → 4GR/4GR → 3GR → 2GR → 1GR) in combination with shift valve A.
Overrun clutch control valve	Switches hydraulic circuits to prevent engagement of the overrun clutch simultaneously with application of the brake band in D4. (Interlocking occurs if the overrun clutch engages during D4.)
1st reducing valve	Reduces low & reverse brake pressure to dampen engine-brake shock when downshifting from the 1st position 12 to 11.
Overrun clutch reducing valve	Reduces oil pressure directed to the overrun clutch and prevents engine-brake shock. In the 1st and 2nd positions, line pressure acts on the overrun clutch reducing valve to increase the pressure-regulating point, with resultant engine brake capability.
Torque converter relief valve	Prevents an excessive rise in torque converter pressure.
Torque converter clutch control valve, plug and sleeve	Activates or inactivates the lock-up function. Also provides smooth lock-up through transient application and release of the lock-up system.
1-2 accumulator valve and piston	Lessens the shock find when the 2GR band servo contracts, and provides smooth shifting.
3-2 timing valve	Switches the pace that oil pressure is released depending on vehicle speed; maximizes the high clutch release timing, and allows for soft downshifting.
Shuttle valve	Determines if the overrun clutch solenoid valve should control the 3-2 timing valve or the overrun clutch control valve and switches between the two.
Cooler check valve	At low speeds and with a small load when a little heat is generated, saves the volume of cooler flow, and stores the oil pressure for lock-up.

Centrifugal Cancel Mechanism

INFOID:000000005928083

FUNCTION

The centrifugal cancel mechanism is a mechanism to cancel the centrifugal hydraulic pressure instead of the conventional check balls. It cancels the centrifugal hydraulic pressure which is generated as high clutch drum rotates, and it allows for preventing high clutch from dragging and for providing stable high clutch piston pressing force in all revolution speeds.

STRUCTURE/OPERATION

A/T CONTROL SYSTEM

< SERVICE INFORMATION >

A centrifugal cancel housing is provided to cancel the clutch housing pressure. The centrifugal cancel housing is always filled with ATF from the dedicated fluid passage of oil pump.

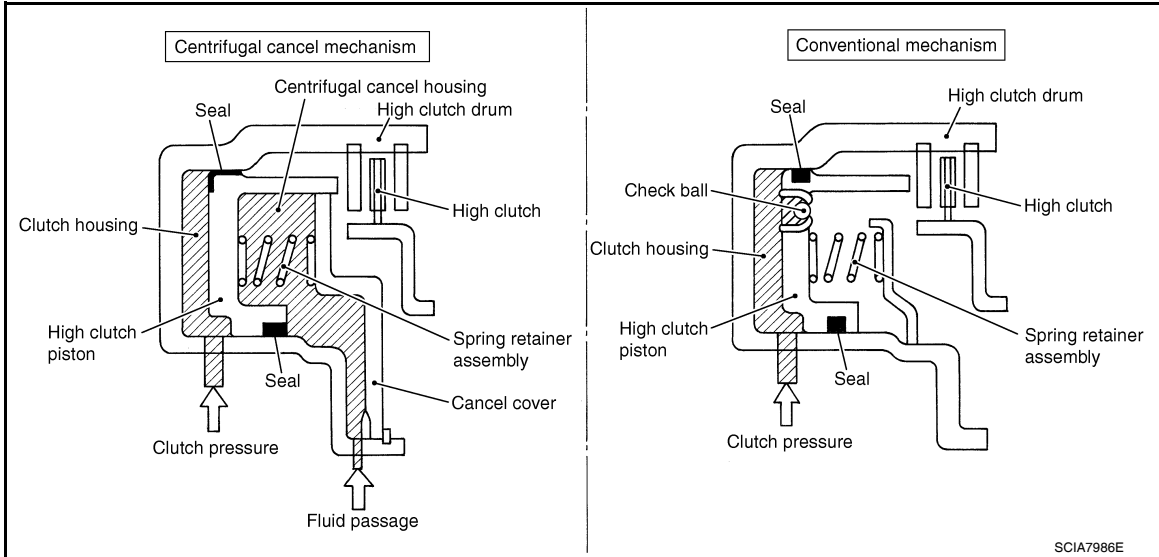

When Clutch Pressure Is Not Applied

As high clutch drum rotates, a centrifugal force applies to the remaining ATF in clutch housing to push high clutch piston. However, on the other hand, the centrifugal force also applies to ATF filled in centrifugal cancel housing, resulting in a force that pushes high clutch piston back. Consequently the high clutch piston does not move because both forces cancel each other, and thus high clutch is prevented from dragging.

When Clutch Pressure Is Applied

Clutch pressure that applies to clutch housing overcomes the fluid pressure and spring force of the opposing centrifugal housing to push high clutch piston, and high clutch is engaged. At this time, the centrifugal force caused by the revolution speed of high clutch drum has no impact any more since the centrifugal force that applies to the clutch pressure of clutch housing is canceled by the centrifugal force that applies to centrifugal cancel housing. As a result, high clutch piston pressing force is always stable in all revolution speeds, and thus smooth shifting characteristics are achieved.

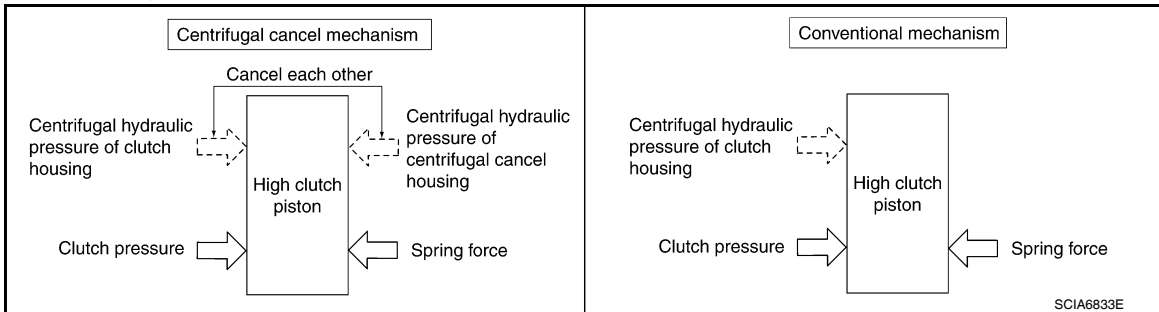

ON BOARD DIAGNOSTIC (OBD) SYSTEM

< SERVICE INFORMATION >

ON BOARD DIAGNOSTIC (OBD) SYSTEM

Introduction

INFOID:000000005928084

A/T system has two self-diagnostic systems.

The first is emission-related on board diagnostic system (OBD-II) performed by the TCM in combination with the ECM. The malfunction is indicated by the MIL (malfunction indicator lamp) and is stored as a DTC in the ECM memory but not the TCM memory.

The second is the TCM original self-diagnosis indicated by the OD OFF indicator lamp. The malfunction is stored in the TCM memory. The detected items are overlapped with OBD-II self-diagnostic items. For detail, refer to [AT-77. "CONSULT-III Function \(TRANSMISSION\)"](#).

OBD-II Function for A/T System

INFOID:000000005928085

The ECM provides emission-related on board diagnostic (OBD-II) functions for the A/T system. One function is to receive a signal from the TCM used with OBD-related parts of the A/T system. The signal is sent to the ECM when a malfunction occurs in the corresponding OBD-related part. The other function is to indicate a diagnostic result by means of the MIL (malfunction indicator lamp) on the instrument panel. Sensors, switches and solenoid valves are used as sensing elements.

The MIL automatically illuminates in One or Two Trip Detection Logic when a malfunction is sensed in relation to A/T system parts.

One or Two Trip Detection Logic of OBD-II

INFOID:000000005928086

ONE TRIP DETECTION LOGIC

If a malfunction is sensed during the first test drive, the MIL will illuminate and the malfunction will be stored in the ECM memory as a DTC. The TCM is not provided with such a memory function.

TWO TRIP DETECTION LOGIC

When a malfunction is sensed during the first test drive, it is stored in the ECM memory as a 1st trip DTC (diagnostic trouble code) or 1st trip freeze frame data. At this point, the MIL will not illuminate. — 1st trip

If the same malfunction as that experienced during the first test drive is sensed during the second test drive, the MIL will illuminate. — 2nd trip

The "trip" in the "One or Two Trip Detection Logic" means a driving mode in which self-diagnosis is performed during vehicle operation.

OBD-II Diagnostic Trouble Code (DTC)

INFOID:000000005928087

HOW TO READ DTC AND 1ST TRIP DTC

DTC and 1st trip DTC can be read by the following methods.

( with **CONSULT-III** or ( **GST**) CONSULT-III or GST (Generic Scan Tool) Examples: P0705, P0720 etc.

These DTC are prescribed by SAE J2012.

(CONSULT-III also displays the malfunctioning component or system.)

- **1st trip DTC No. is the same as DTC No.**
- **Output of the diagnostic trouble code indicates that the indicated circuit has a malfunction. However, in case of the Mode II and GST, they do not indicate whether the malfunction is still occurring or occurred in the past and returned to normal.**
CONSULT-III can identify them as shown below, therefore, CONSULT-III (if available) is recommended.

DTC or 1st trip DTC of a malfunction is displayed in SELF-DIAGNOSTIC RESULTS mode for "ENGINE" with CONSULT-III. Time data indicates how many times the vehicle was driven after the last detection of a DTC.

If the DTC is being detected currently, the time data will be "0".

If a 1st trip DTC is stored in the ECM, the time data will be "1t".

Freeze Frame Data and 1st Trip Freeze Frame Data

The ECM has a memory function, which stores the driving condition such as fuel system status, calculated load value, engine coolant temperature, short term fuel trim, long term fuel trim, engine speed and vehicle speed at the moment the ECM detects a malfunction.

ON BOARD DIAGNOSTIC (OBD) SYSTEM

< SERVICE INFORMATION >

Data which are stored in the ECM memory, along with the 1st trip DTC, are called 1st trip freeze frame data, and the data, stored together with the DTC data, are called freeze frame data and displayed on CONSULT-III or GST. The 1st trip freeze frame data can only be displayed on the CONSULT-III screen, not on the GST. For detail, refer to [EC-106. "CONSULT-III Function" \(HR16DE\)](#), [EC-612. "CONSULT-III Function \(ENGINE\)" \(MR18DE\)](#).

Only one set of freeze frame data (either 1st trip freeze frame data or freeze frame data) can be stored in the ECM. 1st trip freeze frame data is stored in the ECM memory along with the 1st trip DTC. There is no priority for 1st trip freeze frame data and it is updated each time a different 1st trip DTC is detected. However, once freeze frame data (2nd trip detection/MIL on) is stored in the ECM memory, 1st trip freeze frame data is no longer stored. Remember, only one set of freeze frame data can be stored in the ECM. The ECM has the following priorities to update the data.

Priority	Items	
1	Freeze frame data	Misfire — DTC: P0300 - P0306 Fuel Injection System Function — DTC: P0171, P0172, P0174, P0175
2		Except the above items (Includes A/T related items)
3	1st trip freeze frame data	

Both 1st trip freeze frame data and freeze frame data (along with the DTC) are cleared when the ECM memory is erased.

HOW TO ERASE DTC

The diagnostic trouble code can be erased by CONSULT-III, GST or ECM DIAGNOSTIC TEST MODE as described following.

- **If the battery cable is disconnected, the diagnostic trouble code will be cleared within 24 hours.**
- **When you erase the DTC, using CONSULT-III or GST is easier and quicker than switching the mode selector on the ECM.**

The following emission-related diagnostic information is cleared from the ECM memory when erasing DTC related to OBD-II. For details, refer to [EC-95. "Diagnosis Description" \(HR16DE\)](#), [EC-542. "Emission-related Diagnostic Information" \(MR18DE\)](#).

- **Diagnostic trouble codes (DTC)**
- **1st trip diagnostic trouble codes (1st trip DTC)**
- **Freeze frame data**
- **1st trip freeze frame data**
- **System readiness test (SRT) codes**
- **Test values**

HOW TO ERASE DTC (WITH CONSULT-III)

- **If a DTC is displayed for both ECM and TCM, it is necessary to be erased for both ECM and TCM.**
1. If the ignition switch stays ON after repair work, be sure to turn ignition switch OFF once. Wait at least 10 seconds and then turn it ON (engine stopped) again.
 2. Turn CONSULT-III "ON" and touch "TRANSMISSION".
 3. Touch "SELF-DIAG RESULTS".
 4. Touch "ERASE". (The DTC in the TCM will be erased.) Then touch "BACK" twice.
 5. Touch "ENGINE".
 6. Touch "SELF-DIAG RESULTS".
 7. Touch "ERASE". (The DTC in the ECM will be erased.)

HOW TO ERASE DTC (WITH GST)

1. If the ignition switch stays ON after repair work, be sure to turn ignition switch OFF once. Wait at least 10 seconds and then turn it ON (engine stopped) again.
2. Perform "TCM SELF-DIAGNOSTIC PROCEDURE (No Tools)". Refer to [AT-82. "Diagnosis Procedure without CONSULT-III"](#). (The engine warm-up step can be skipped when performing the diagnosis only to erase the DTC.)
3. Select Mode 4 with Generic Scan Tool (GST). For details, refer to [EC-103. "On Board Diagnosis Function" \(HR16DE\)](#), [EC-618. "Generic Scan Tool \(GST\) Function" \(MR18DE\)](#).

HOW TO ERASE DTC (NO TOOLS)

ON BOARD DIAGNOSTIC (OBD) SYSTEM

< SERVICE INFORMATION >

The OD OFF indicator lamp is located on the combination meter.

1. If the ignition switch stays ON after repair work, be sure to turn ignition switch OFF once. Wait at least 10 seconds and then turn it ON (engine stopped) again.
2. Perform "TCM SELF-DIAGNOSTIC PROCEDURE (No Tools)". Refer to [AT-82, "Diagnosis Procedure without CONSULT-III"](#). (The engine warm-up step can be skipped when performing the diagnosis only to erase the DTC.)
3. Perform "OBD-II SELF-DIAGNOSTIC PROCEDURE (No tools)". Refer to [EC-95, "Diagnosis Description" \(HR16DE\)](#), [EC-542, "Emission-related Diagnostic Information" \(MR18DE\)](#).

Malfunction Indicator Lamp (MIL)

INFOID:000000005928088

DESCRIPTION

The MIL is located on the instrument panel.

1. The MIL will light up when the ignition switch is turned ON without the engine running. This is a bulb check.
 - If the MIL does not light up, refer to [DI-21, "Schematic"](#), [EC-450, "Wiring Diagram" \(HR16DE\)](#), [EC-1033, "Wiring Diagram" \(MR18DE\)](#).
2. When the engine is started, the MIL should go off.
 - If the MIL remains on, the on board diagnostic system has detected an engine system malfunction.

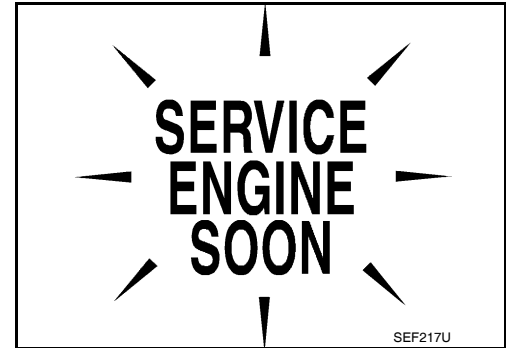

TROUBLE DIAGNOSIS

< SERVICE INFORMATION >

TROUBLE DIAGNOSIS

DTC Inspection Priority Chart

INFOID:000000005928089

If some DTCs are displayed at the same time, perform inspections one by one based on the following priority chart.

NOTE:

If DTC “CAN COMM CIRCUIT” is displayed with other DTCs, first perform the trouble diagnosis for DTC “CAN COMM CIRCUIT”. Refer to [AT-87](#).

Priority	Detected items
1	CAN communication line
2	Except above

Fail-Safe

INFOID:000000005928090

The TCM has an electronic Fail-safe mode. This allows the vehicle to be driven even if a major electrical input/output device circuit is damaged.

Under Fail-Safe, the vehicle always runs in 3GR, even with a shift lever position of “1”, “2” or “D”. The customer may complain of sluggish or poor acceleration.

Always follow the [“AT-43. How to Perform Trouble Diagnosis for Quick and Accurate Repair”](#).

The SELF-DIAGNOSIS results will be as follows:

- The first SELF-DIAGNOSIS will indicate damage to the vehicle speed signal or the output speed sensor.
- During the next SELF-DIAGNOSIS, performed after checking the sensor, no damages will be indicated.

FAIL-SAFE FUNCTION

The following fail-safe functions allow vehicles to be driven even when sensor, switch or solenoid malfunction occurs.

Output Speed Sensor

Vehicle speed signal is input from combination meter.

Accelerator Pedal Position Signal and Throttle Position Signal

TCM controls the throttle opening angle to a predetermined fixed position to enable driving if a malfunctioning signal is input to TCM.

Transmission Range Switch

When the multiple transmission range switch signals are input to TCM, the priority of selector lever position becomes “D”, “N”, “R”, “2” and “1” in order by internal TCM determination.

The use of 4GR is inhibited until normal operation resumes. Because the hydraulic circuit of the control valve is switched by manual valve according to the selector lever position, however, actual operating condition of vehicle becomes as follows.

Actual lever position	Transmission range switch input signal	Running status
“P”	“P” position and other position signals	P
“R”	“R” position and other position signals	R
“N”	“N” position and other position signals	N
“D”	“D” position and other position signals	D1 ↔D2 ↔D3 ↔D4
“2”	“2” position and other position signals (Except “1” position)	21 ↔22 ↔23
	“2” position and “1” position signals	21 ↔22
“1”	“1” position and other position signals (Except “2” position)	11 ↔12 ↔13
	“1” position and “2” position signals	11 ↔12

Shift Solenoid Valve A and B

If non-standard solenoid signal is sent to TCM, use of certain gears is limited. Refer to chart shown below.

TROUBLE DIAGNOSIS

< SERVICE INFORMATION >

Shift position	Normal			Malfunction in solenoid valve A			Malfunction in solenoid valve B			Malfunction in solenoid valves A and B		
	A	B	Gear	A	B	Gear	A	B	Gear	A	B	Gear
"D" position	●	●	1st	—	●→×	3rd	●→×	—	3rd	—	—	3rd
	×	●	2nd	—	●→×		×	—		—	—	
	×	×	3rd	—	×		×	—		—	—	
	●	×	4th	—	×		●→×	—		—	—	
"2" position	●	●	1st	—	●→×	3rd	●→×	—	3rd	—	—	3rd
	×	●	2nd	—	●→×		×	—		—	—	
	×	×	3rd	—	×		×	—		—	—	
"1" position	●	●	1st	—	●→×	3rd	●→×	—	3rd	—	—	3rd
	×	●	2nd	—	●→×		×	—		—	—	
	×	×	3rd	—	×		×	—		—	—	

- : Solenoid ON
- ×: Solenoid OFF
- : Non-standard condition

Line Pressure Solenoid Valve

If non-standard solenoid signal is sent to TCM, line pressure solenoid valve is turned OFF to achieve maximum oil pressure.

Torque Converter Clutch Solenoid Valve

If non-standard solenoid signal is sent to TCM, torque converter clutch solenoid valve is turned OFF to release lock-up.

Overrun Clutch Solenoid Valve

If non-standard solenoid signal is sent to TCM, overrun clutch solenoid valve is turned OFF to engage overrun clutch. This will result in more effective engine brake during deceleration.

How to Perform Trouble Diagnosis for Quick and Accurate Repair

INFOID:000000005928091

INTRODUCTION

The TCM receives a signal from the vehicle speed sensor, accelerator pedal position sensor or transmission range switch and provides shift control or lock-up control via A/T solenoid valves.

The TCM also communicates with the ECM by means of a signal sent from sensing elements used with the OBD-related parts of the A/T system for malfunction-diagnostic purposes. The TCM is capable of diagnosing malfunctioning parts while the ECM can store malfunctions in its memory.

Input and output signals must always be correct and stable in the operation of the A/T system. The A/T system must be in good operating condition and be free of valve seizure, solenoid valve malfunction, etc.

It is much more difficult to diagnose a malfunction that occurs intermittently rather than continuously. Most intermittent malfunctions are caused by poor electric connections or improper wiring. In this case, careful checking of suspected circuits may help prevent the replacement of good parts.

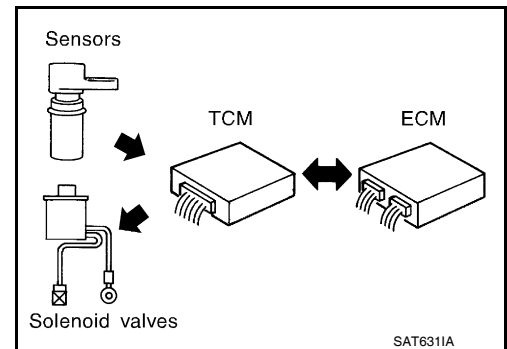

TROUBLE DIAGNOSIS

< SERVICE INFORMATION >

A visual check only, may not find the cause of the malfunctions. A road test with CONSULT-III or a circuit tester connected should be performed. Follow the "WORK FLOW" .

Before undertaking actual checks, take a few minutes to talk with a customer who approaches with a driveability complaint. The customer can supply good information about such malfunctions, especially intermittent ones. Find out what symptoms are present and under what conditions they occur. A "DIAGNOSTIC WORKSHEET" like the example ("DIAGNOSTIC WORKSHEET") should be used. Start your diagnosis by looking for "conventional" malfunctions first. This will help troubleshoot driveability malfunctions on an electronically controlled engine vehicle.

Also check related Service bulletins for information.

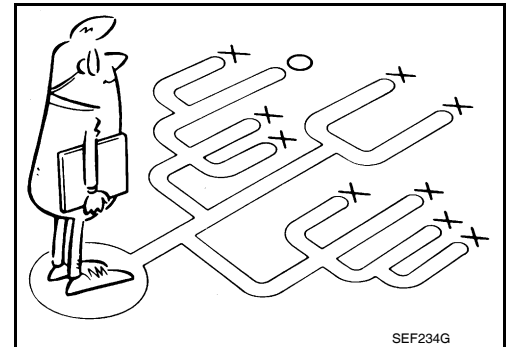
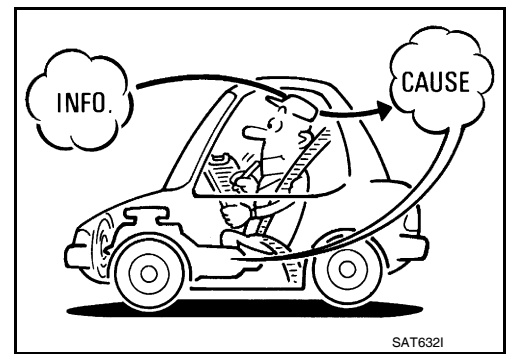

WORK FLOW

A good understanding of the malfunction conditions can make troubleshooting faster and more accurate. In general, each customer feels differently about a malfunction. It is important to fully understand the symptoms or conditions for a customer complaint.

Make good use of the two sheets provided, "Information from customer" and "Diagnostic Worksheet Chart" , to perform the best troubleshooting possible.

Work Flow Chart

TROUBLE DIAGNOSIS

< SERVICE INFORMATION >

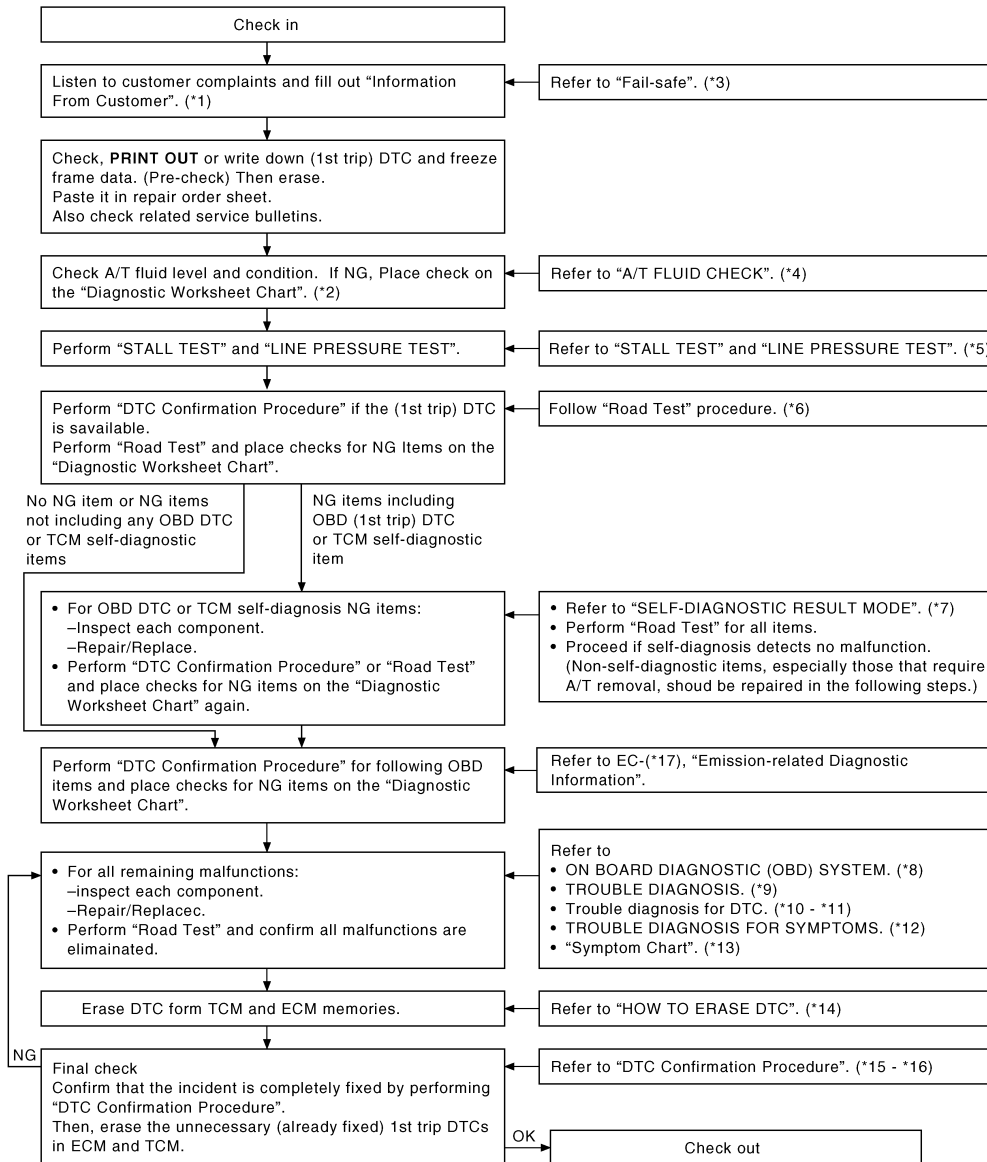

SCIA7146E

- | | | |
|--------------------------------|---|----------------------------|
| *1 "Information from customer" | *2 "Diagnostic Worksheet Chart" | *3 AT-42 |
| *4 AT-51 | *5 AT-51, AT-51 | *6 AT-55 |
| *7 AT-77 | *8 AT-39 | *9 AT-42 |
| *10 AT-100 | *11 AT-167 | *12 AT-177 |
| *13 AT-65 | *14 AT-39 | *15 AT-87 |
| *16 AT-167 | *17 EC-95 (HR16DE), EC-542 (MR18DE) | |

DIAGNOSTIC WORKSHEET

Information from Customer

KEY POINTS

- **WHAT**..... Vehicle & A/T model
- **WHEN**..... Date, Frequencies
- **WHERE**..... Road conditions
- **HOW**..... Operating conditions, Symptoms

TROUBLE DIAGNOSIS

< SERVICE INFORMATION >

Customer name MR./MS	Model & Year	VIN
Trans. model	Engine	Mileage
Incident Date	Manuf. Date	In Service Date
Frequency	<input type="checkbox"/> Continuous <input type="checkbox"/> Intermittent (times a day)	
Symptoms	<input type="checkbox"/> Vehicle does not move. (<input type="checkbox"/> Any position <input type="checkbox"/> Particular position)	
	<input type="checkbox"/> No up-shift (<input type="checkbox"/> 1st → 2nd <input type="checkbox"/> 2nd → 3rd <input type="checkbox"/> 3rd → 4th)	
	<input type="checkbox"/> No down-shift (<input type="checkbox"/> 4th → 3rd <input type="checkbox"/> 3rd → 2nd <input type="checkbox"/> 2nd → 1st)	
	<input type="checkbox"/> Lock-up malfunction	
	<input type="checkbox"/> Shift point too high or too low.	
	<input type="checkbox"/> Shift shock or slip (<input type="checkbox"/> N → D <input type="checkbox"/> Lock-up <input type="checkbox"/> Any drive position)	
	<input type="checkbox"/> Noise or vibration	
	<input type="checkbox"/> No kick down	
	<input type="checkbox"/> No pattern select	
	<input type="checkbox"/> Others ()	
Malfunction indicator lamp (MIL)	<input type="checkbox"/> Continuously lit	<input type="checkbox"/> Not lit

Diagnostic Worksheet Chart

1.	<input type="checkbox"/> Read the Fail-safe and listen to customer complaints.	AT-42 , "Information from customer"		
2.	<input type="checkbox"/> Check A/T fluid	AT-17		
	<input type="checkbox"/> Leakage (Follow specified procedure) <input type="checkbox"/> Fluid condition <input type="checkbox"/> Fluid level			
3.	<input type="checkbox"/> Perform "STALL TEST" and "LINE PRESSURE TEST".	AT-51		
	<input type="checkbox"/> "STALL TEST"— Mark possible damaged components/others.			
	<table style="width: 100%; border: none;"> <tr> <td style="width: 50%; border: none;"> <input type="checkbox"/> Torque converter one-way clutch <input type="checkbox"/> Reverse clutch <input type="checkbox"/> Forward clutch <input type="checkbox"/> Overrun clutch <input type="checkbox"/> Forward one-way clutch </td> <td style="width: 50%; border: none;"> <input type="checkbox"/> Low & reverse brake <input type="checkbox"/> Low one-way clutch <input type="checkbox"/> Engine <input type="checkbox"/> Line pressure is low <input type="checkbox"/> Clutches and brakes except high clutch and brake band are OK </td> </tr> </table>	<input type="checkbox"/> Torque converter one-way clutch <input type="checkbox"/> Reverse clutch <input type="checkbox"/> Forward clutch <input type="checkbox"/> Overrun clutch <input type="checkbox"/> Forward one-way clutch	<input type="checkbox"/> Low & reverse brake <input type="checkbox"/> Low one-way clutch <input type="checkbox"/> Engine <input type="checkbox"/> Line pressure is low <input type="checkbox"/> Clutches and brakes except high clutch and brake band are OK	
<input type="checkbox"/> Torque converter one-way clutch <input type="checkbox"/> Reverse clutch <input type="checkbox"/> Forward clutch <input type="checkbox"/> Overrun clutch <input type="checkbox"/> Forward one-way clutch	<input type="checkbox"/> Low & reverse brake <input type="checkbox"/> Low one-way clutch <input type="checkbox"/> Engine <input type="checkbox"/> Line pressure is low <input type="checkbox"/> Clutches and brakes except high clutch and brake band are OK			
	<input type="checkbox"/> "LINE PRESSURE TEST"— Suspected parts:			

TROUBLE DIAGNOSIS

< SERVICE INFORMATION >

4.	<input type="checkbox"/> Perform "Road Test".		AT-55	
4-1.	"Check Before Engine is Started"		AT-56	A
	<input type="checkbox"/> AT-180 . "OD OFF Indicator Lamp Does Not Come On"			B
	<input type="checkbox"/> Perform self-diagnosis. Enter checks for detected items. AT-77 , AT-82 .			AT
	<input type="checkbox"/> CAN COMM CIRCUIT AT-87 .			D
	<input type="checkbox"/> TRANSMISSION RANGE SWITCH A AT-90 .			E
	<input type="checkbox"/> TRANSMISSION FLUID TEMPERATURE SENSOR A AT-95 .			F
	<input type="checkbox"/> OUTPUT SPEED SENSOR AT-100 .			G
	<input type="checkbox"/> ENGINE SPEED AT-105 .			H
	<input type="checkbox"/> 1GR INCORRECT RATIO AT-109			I
	<input type="checkbox"/> 2GR INCORRECT RATIO AT-112 .			J
	<input type="checkbox"/> 3GR INCORRECT RATIO AT-115 .			K
	<input type="checkbox"/> 4GR INCORRECT RATIO AT-118 .			L
	<input type="checkbox"/> TORQUE CONVERTER AT-123 .			M
	<input type="checkbox"/> TORQUE CONVERTER AT-128 .			N
	<input type="checkbox"/> PRESSURE CONTROL SOLENOID A AT-133 .			O
	<input type="checkbox"/> SHIFT SOLENOID A AT-138 .			P
	<input type="checkbox"/> SHIFT SOLENOID B AT-143 .			
	<input type="checkbox"/> OVERRUN CLUTCH SOLENOID AT-148 .			
	<input type="checkbox"/> VEHICLE SPEED SIGNAL AT-153 .			
	<input type="checkbox"/> BATT/FLUID TEMP SEN AT-156 .			
	<input type="checkbox"/> INPUT SPEED SENSOR A AT-162 .			
	<input type="checkbox"/> CONTROL UNIT (RAM), CONTROL UNIT (ROM) AT-167 .			
	<input type="checkbox"/> MAIN POWER SUPPLY AND GROUND CIRCUIT AT-168 .			
4-2.	"Check at Idle"		AT-56	H
	<input type="checkbox"/> AT-182 . "Engine Cannot Be Started in "P" and "N" Position" .			I
	<input type="checkbox"/> AT-183 . "In "P" Position, Vehicle Moves Forward or Backward When Pushed" .			J
	<input type="checkbox"/> AT-183 . "In "N" Position, Vehicle Moves" .			K
	<input type="checkbox"/> AT-184 . "Large Shock "N" → "R" Position" .			L
	<input type="checkbox"/> AT-185 . "Vehicle Does Not Creep Backward in "R" Position" .			M
	<input type="checkbox"/> AT-186 . "Vehicle Does Not Creep Forward in "D". "2" or "1" Position" .			N

TROUBLE DIAGNOSIS

< SERVICE INFORMATION >

4.	4-3.	"Cruise Test"	AT-58
		<p>Part 1</p> <ul style="list-style-type: none"> <input type="checkbox"/> AT-187, "Vehicle Cannot Be Started from D1" . <input type="checkbox"/> AT-189, "A/T Does Not Shift: D1→ D2or Does Not Kickdown: D4→ D2" . <input type="checkbox"/> AT-190, "A/T Does Not Shift: D2→ D3" . <input type="checkbox"/> AT-192, "A/T Does Not Shift: D3→ D4" . <input type="checkbox"/> AT-193, "A/T Does Not Perform Lock-up" . <input type="checkbox"/> AT-194, "A/T Does Not Hold Lock-up Condition" . <input type="checkbox"/> AT-195, "Lock-up Is Not Released" . <input type="checkbox"/> AT-196, "Engine Speed Does Not Return to Idle (Light Braking D4→ D3)" . 	
		<p>Part 2</p> <ul style="list-style-type: none"> <input type="checkbox"/> AT-187, "Vehicle Cannot Be Started from D1" . <input type="checkbox"/> AT-189, "A/T Does Not Shift: D1→ D2or Does Not Kickdown: D4→ D2" . <input type="checkbox"/> AT-190, "A/T Does Not Shift: D2→ D3" . <input type="checkbox"/> AT-192, "A/T Does Not Shift: D3→ D4" . 	AT-61
		<p>Part 3</p> <ul style="list-style-type: none"> <input type="checkbox"/> AT-197, "A/T Does Not Shift: D4→ D3. When OD OFF" . <input type="checkbox"/> AT-198, "A/T Does Not Shift: D3→ 22. When Selector Lever "D" → "2" Position" . <input type="checkbox"/> AT-199, "A/T Does Not Shift: 22→ 11. When Selector Lever "2" → "1" Position" . <input type="checkbox"/> AT-201, "Vehicle Does Not Decelerate by Engine Brake" . <input type="checkbox"/> Perform self-diagnosis. Enter checks for detected items. AT-77 , AT-82 . 	AT-62
		<ul style="list-style-type: none"> <input type="checkbox"/> CAN COMM CIRCUIT AT-87 . <input type="checkbox"/> TRANSMISSION RANGE SWITCH A AT-90 . <input type="checkbox"/> TRANSMISSION FLUID TEMPERATURE SENSOR A AT-95 . <input type="checkbox"/> OUTPUT SPEED SENSOR AT-100 . <input type="checkbox"/> ENGINE SPEED AT-105 . <input type="checkbox"/> 1GR INCORRECT RATIO AT-109 <input type="checkbox"/> 2GR INCORRECT RATIO AT-112 . <input type="checkbox"/> 3GR INCORRECT RATIO AT-115 . <input type="checkbox"/> 4GR INCORRECT RATIO AT-118 . <input type="checkbox"/> TORQUE CONVERTER AT-123 . <input type="checkbox"/> TORQUE CONVERTER AT-128 . <input type="checkbox"/> PRESSURE CONTROL SOLENOID A AT-133 . <input type="checkbox"/> SHIFT SOLENOID A AT-138 . <input type="checkbox"/> SHIFT SOLENOID B AT-143 . <input type="checkbox"/> OVERRUN CLUTCH SOLENOID AT-148 . <input type="checkbox"/> VEHICLE SPEED SIGNAL AT-153 . <input type="checkbox"/> BATT/FLUID TEMP SEN AT-156 . <input type="checkbox"/> INPUT SPEED SENSOR A AT-162 . <input type="checkbox"/> CONTROL UNIT (RAM), CONTROL UNIT (ROM) AT-167 . <input type="checkbox"/> MAIN POWER SUPPLY AND GROUND CIRCUIT AT-168 . 	
5.		<input type="checkbox"/> For self-diagnosis NG items, inspect each component. Repair or replace the damaged parts.	AT-77 , AT-82
6.		<input type="checkbox"/> Perform "Road Test".	AT-55
7.		<input type="checkbox"/> Perform the Diagnostic Procedures for all remaining items marked NG. Repair or replace the damaged parts. Refer to the Symptom Chart when you perform the procedures. (The chart also shows some other possible symptoms and the component inspection orders.)	AT-65
8.		<input type="checkbox"/> Erase DTC from TCM and ECM memories.	AT-39 , AT-82

TROUBLE DIAGNOSIS

< SERVICE INFORMATION >

A/T Electrical Parts Location

INFOID:000000005928092

A
B
AT
D
E
F
G
H
I
J
K
L
M
N
O
P

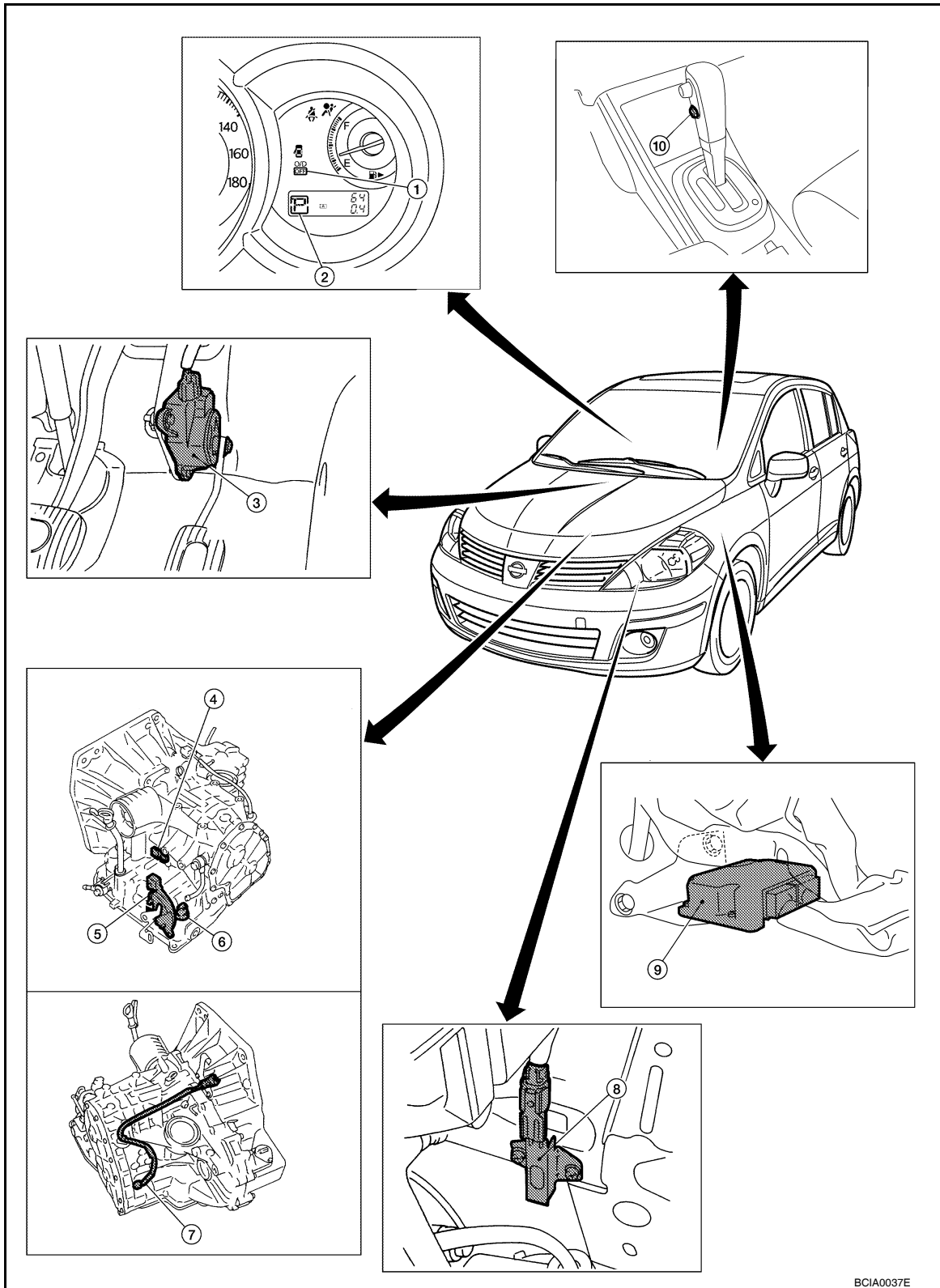

- | | | |
|--------------------------|------------------------------|---|
| 1. OD OFF indicator lamp | 2. Shift position indicator | 3. Accelerator pedal position (APP) sensor |
| 4. Input speed sensor | 5. Transmission range switch | 6. Terminal body (Terminal cord assembly connector) |

TROUBLE DIAGNOSIS

< SERVICE INFORMATION >

- 7. Output speed sensor
- 8. Dropping resistor
- 9. TCM
- 10. Overdrive control switch

Circuit Diagram

INFOID:000000005928093

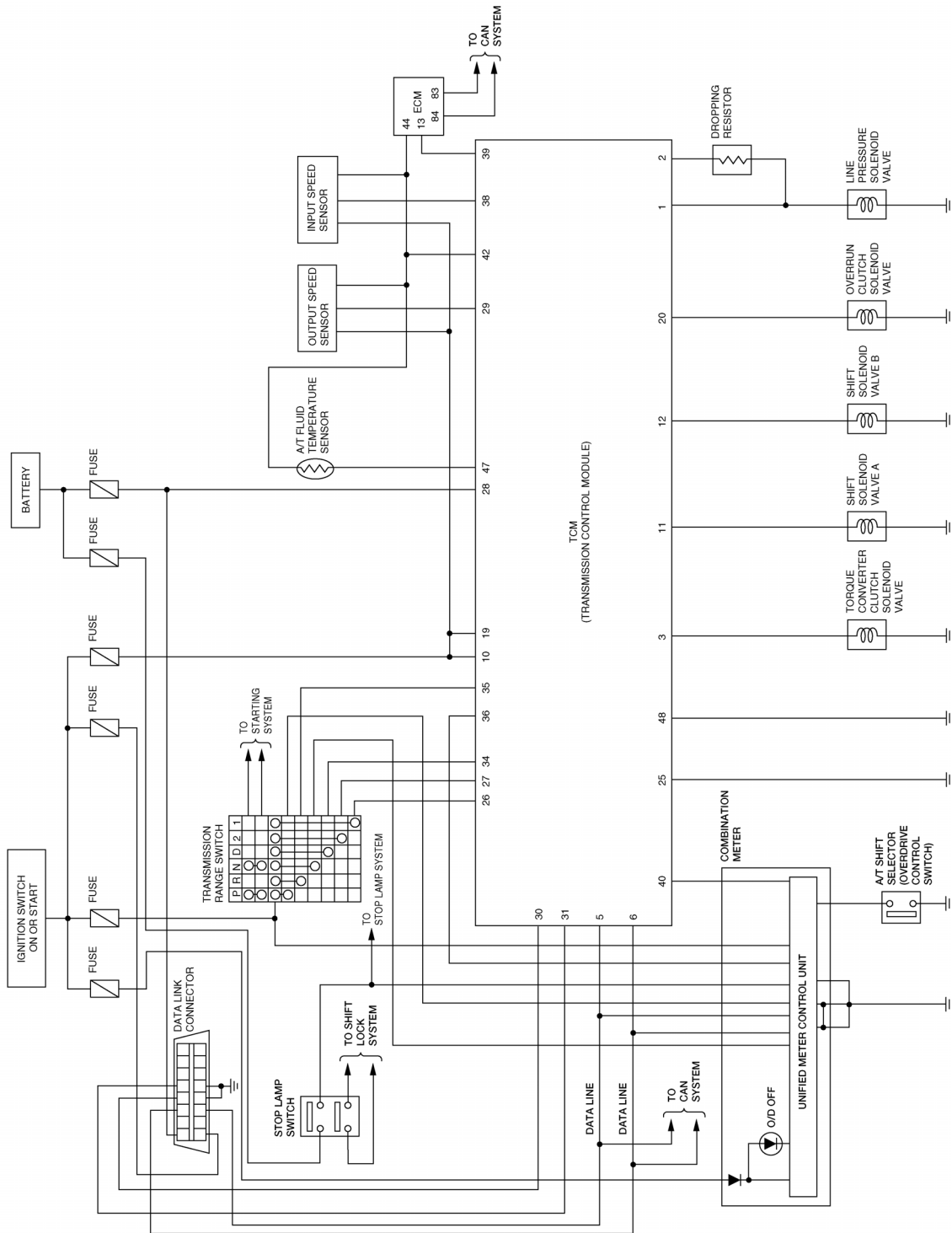

ABDWA0413GB

TROUBLE DIAGNOSIS

< SERVICE INFORMATION >

Inspections Before Trouble Diagnosis

INFOID:000000005928094

A/T FLUID CHECK

Fluid Leakage and Fluid Level Check

Check fluid leakage and check the fluid level. Refer to [AT-17. "Checking A/T Fluid"](#).

Fluid Condition Check

Check the A/T fluid condition.

Fluid status	Conceivable Cause	Required Operation
Varnished (viscous varnish state)	Clutch, brake scorched	Replace the ATF and check the A/T main unit and the vehicle for malfunctions (wire harnesses, cooler pipes, etc.)
Milky white or cloudy	Water in the ATF	Replace the ATF and check for places where water is getting in.
Large amount of metal powder mixed in	Unusual wear of sliding parts within A/T	Replace the ATF and check for improper operation of the A/T.

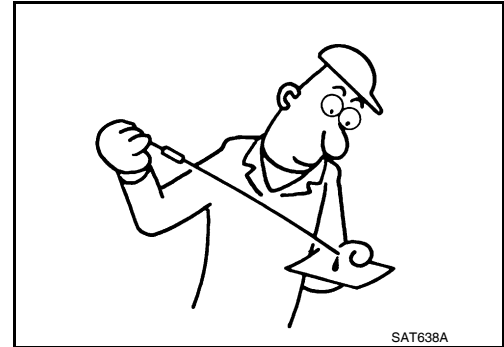

STALL TEST

Stall Test Procedure

1. Check ATF and engine oil levels. If necessary, add ATF and engine oil.
2. Drive vehicle for approximately 10 minutes or until ATF and engine oil reach operating temperature.

ATF operating temperature: 50 - 80°C (122 - 176°F)

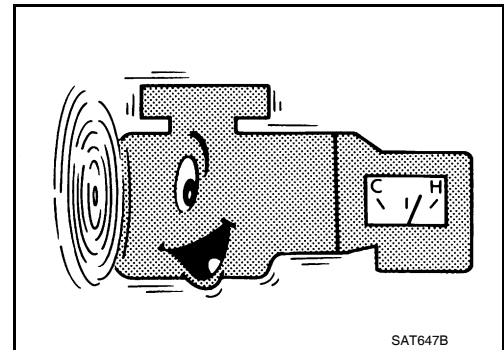

3. Set parking brake and block wheels.
4. Install a tachometer where it can be seen by driver during test.
 - **It is good practice to mark the point of specified engine rpm on indicator.**

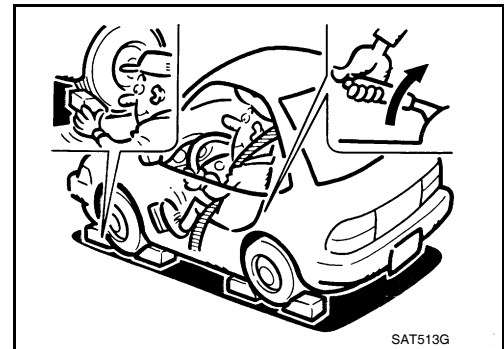

5. Start engine, apply foot brake, and place selector lever in "D" position.

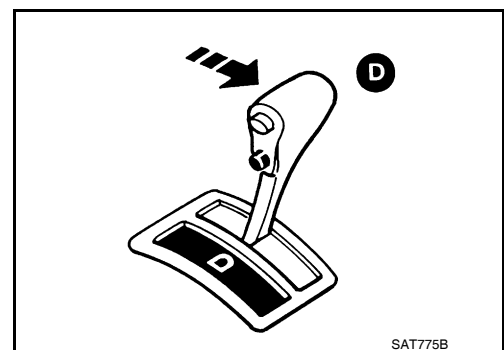

A
B
AT
D
E
F
G
H
I
J
K
L
M
N
O
P

TROUBLE DIAGNOSIS

< SERVICE INFORMATION >

- Accelerate to wide open throttle gradually while applying foot brake.
- Quickly note the engine stall revolution and immediately release throttle.

CAUTION:

Do not hold down the accelerator pedal for more than 5 seconds during this test.

Stall revolution: [AT-374, "Stall Speed"](#)

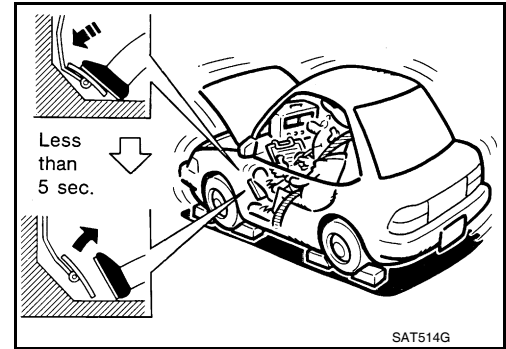

- Move selector lever to "N" position.
 - Cool off ATF.
- CAUTION:**
Run the engine at idle for at least 1 minute.
- Repeat steps 6 through 9 with selector lever in "2", "1" and "R" positions.

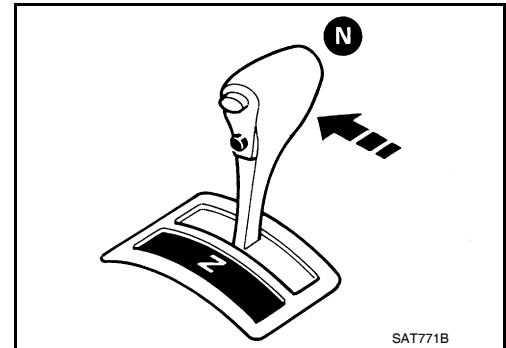

Judgement of Stall Test

The test result and possible damaged components relating to each result are shown in the illustrations on next page.

In order to pinpoint the possible damaged components, refer to [AT-43, "How to Perform Trouble Diagnosis for Quick and Accurate Repair"](#).

NOTE:

Stall revolution is too high in "D", "2", or "1" position:

- Slippage occurs in 1GR but not in 2GR and 3GR. Low one-way clutch slippage
- Slippage occurs in the following gears:
 - 1GR through 3GR in "D" position and engine brake functions with OD OFF. (OD OFF indicator lamp is on.)
 - 1GR and 2GR in "2" position and engine brake functions with accelerator pedal released (fully closed throttle)..... Forward clutch or forward one-way clutch slippage

Stall revolution is too high in "R" position:

- Engine brake does not function in "1" position. Low & reverse brake slippage
- Engine brake functions in "1" position. Reverse clutch slippage

Stall revolution within specifications:

- Vehicle does not achieve speed of more than 80 km/h (50 MPH). One-way clutch seizure in torque converter housing

CAUTION:

Be careful because automatic fluid temperature increases abnormally:

- Slippage occurs in 3GR and 4GR in "D" position. High clutch slippage
- Slippage occurs in 2GR and 4GR in "D" position. Brake band slippage
- Engine brake does not function in 2GR and 3GR in "D" position, 2GR in "2" position, and 1GR in "1" position with OD OFF. (OD OFF indicator lamp is on.) Overrun clutch slippage

Stall revolution less than specifications:

- Poor acceleration during starts. One-way clutch seizure in torque converter

TROUBLE DIAGNOSIS

< SERVICE INFORMATION >

Selector lever position	Judgement		
D	H	O	L
2	H	O	L
1	H	O	L
R	O	H	L

O : Stall revolution is normal.
 H : Stall revolution is higher than specified.
 L : Stall revolution is lower than specified.

Damaged components

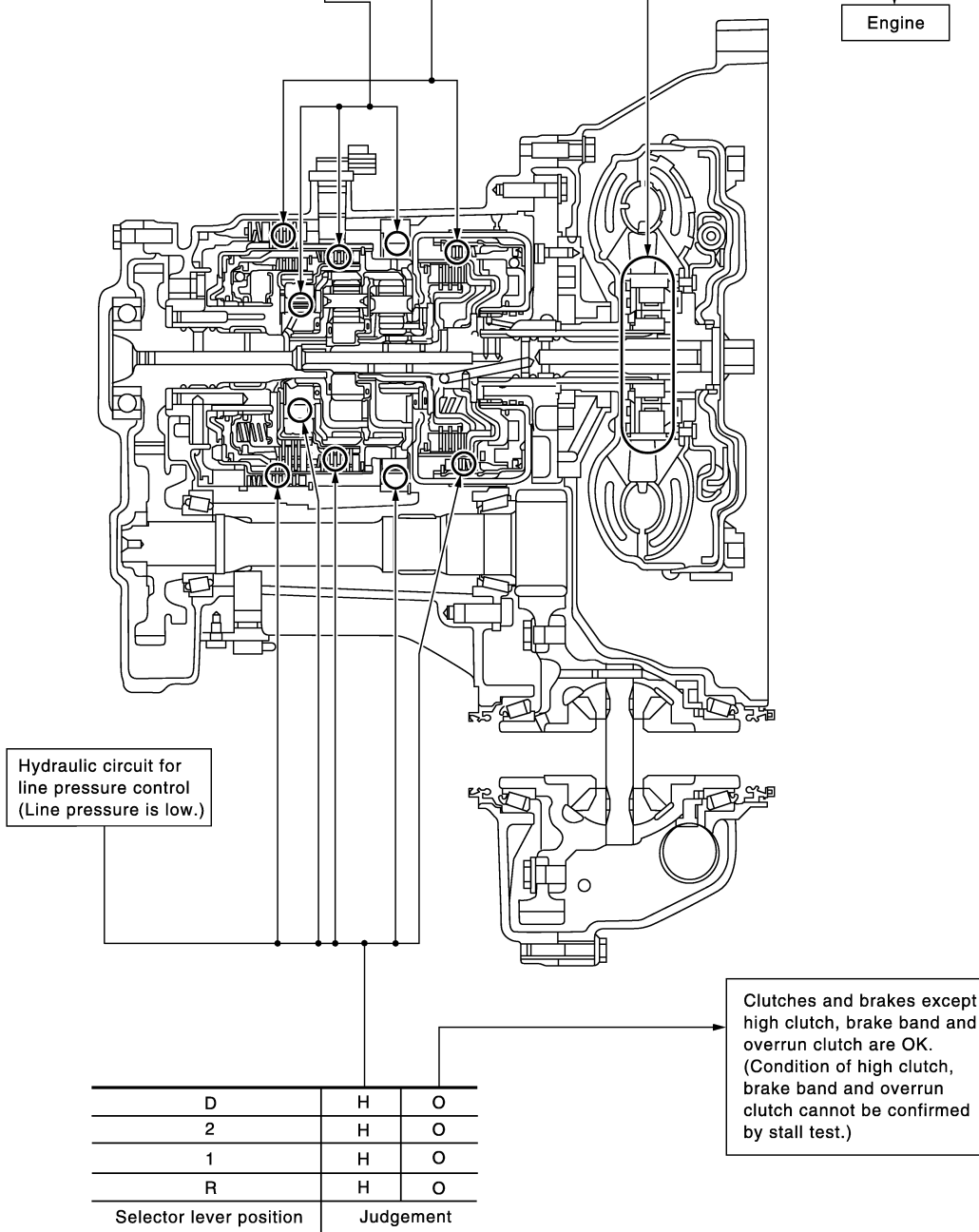

LINE PRESSURE TEST

Line Pressure Test Ports

SCIA7987E

A
B
AT
D
E
F
G
H
I
J
K
L
M
N
O
P

TROUBLE DIAGNOSIS

< SERVICE INFORMATION >

Location of line pressure test ports are shown in the figure.

- **Always replace pressure plugs as they are self-sealing bolts.**

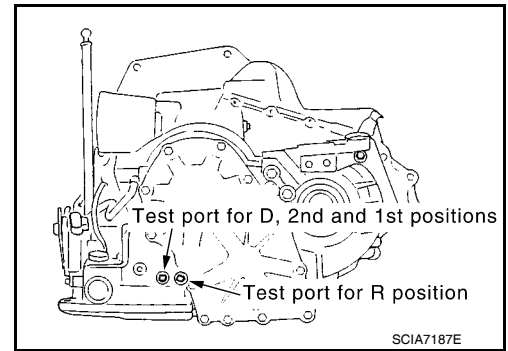

Line Pressure Test Procedure

1. Check ATF and engine oil levels. If necessary, add ATF or engine oil.
2. Drive vehicle for approx. 10 minutes or until engine oil and ATF reach operating temperature.

ATF operating temperature: 50 - 80°C (122 -176°F)

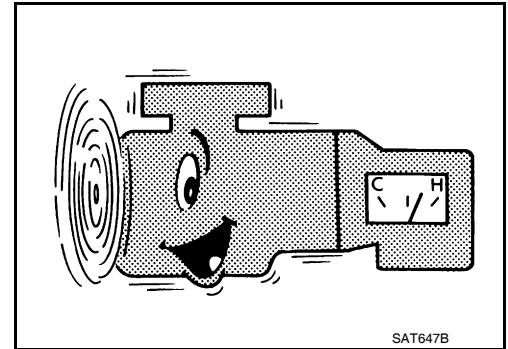

3. Install oil pressure gauge to corresponding line pressure test port.

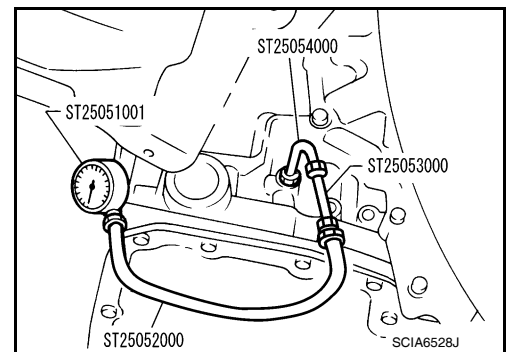

4. Set parking brake and block wheels.

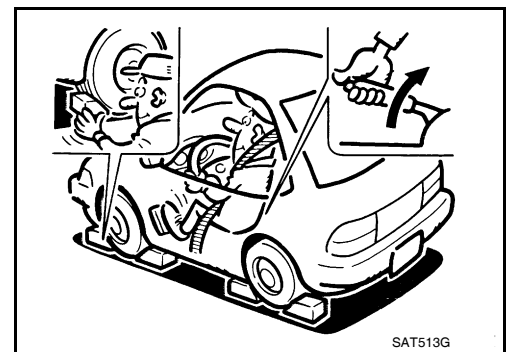

5. Start engine and measure line pressure at idle and stall speed.
CAUTION:
 - **Keep the brake pedal pressed all the way down during measurement.**
 - **When measuring the line pressure at the stall speed, refer to "STALL TEST".**

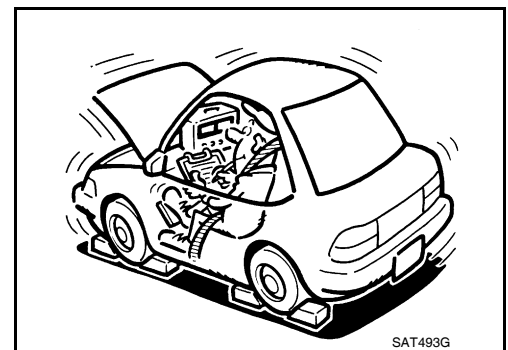

TROUBLE DIAGNOSIS

< SERVICE INFORMATION >

Line Pressure

Engine speed	Line pressure [kPa (kg/cm ² , psi)]	
	D, 2nd and 1st positions	R position
Idle speed	AT-374. "Line Pressure"	
Stall speed		

Judgement of Line Pressure Test

Judgement	Suspected parts
At idle	Line pressure is low in all positions. <ul style="list-style-type: none"> Oil pump wear Control piston damage Pressure regulator valve or plug sticking Spring for pressure regulator valve damaged Fluid pressure leakage between oil strainer and pressure regulator valve Clogged strainer
	Line pressure is low in particular position. <ul style="list-style-type: none"> Fluid pressure leakage between manual valve and particular clutch For example, line pressure is: <ul style="list-style-type: none"> Low in "R" and "1" positions, but Normal in "D", and "2" positions. Therefore, fluid leakage exists at or around low and reverse brake circuit. Refer to AT-22. "Shift Mechanism".
	Line pressure is high. <ul style="list-style-type: none"> Accelerator pedal position signal malfunction A/T fluid temperature sensor damaged Line pressure solenoid valve sticking Short circuit of line pressure solenoid valve circuit Pressure modifier valve sticking Pressure regulator valve or plug sticking Open in dropping resistor circuit
At stall speed	Line pressure is low. <ul style="list-style-type: none"> Accelerator pedal position signal malfunction Line pressure solenoid valve sticking Short circuit of line pressure solenoid valve circuit Pressure regulator valve or plug sticking Pressure modifier valve sticking Pilot valve sticking

Road Test

INFOID:000000005928095

DESCRIPTION

- The purpose of the test is to determine overall performance of A/T and analyze causes of malfunctions.
- The road test consists of the following three parts:
 - Check before engine is started. Refer to [AT-56](#) .
 - Check at idle. Refer to [AT-56](#) .
 - Cruise test
 - Inspection all the item from Part 1 to Part 3. Refer to [AT-58](#) , [AT-61](#) and [AT-62](#) .

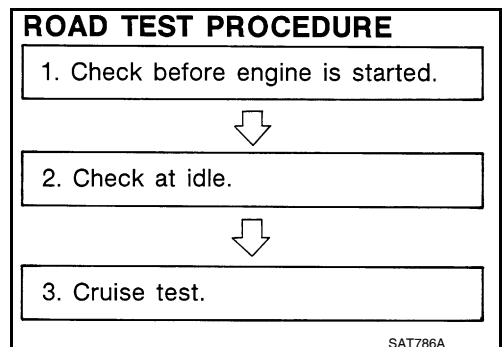

TROUBLE DIAGNOSIS

< SERVICE INFORMATION >

- Before road test, familiarize yourself with all test procedures and items to check.
- Test all inspection items until the symptom is uncovered. Include NG items in "Diagnostic Worksheet Chart"(Refer to [AT-43](#)). Perform a diagnosis of the NG items after the completion of all the road tests.



Check Before Engine Is Started

INFOID:000000005928096

1.CHECK OD OFF INDICATOR LAMP

1. Park vehicle on flat surface.
2. Move selector lever to "P" position.
3. Turn ignition switch OFF. Wait at least 5 seconds.

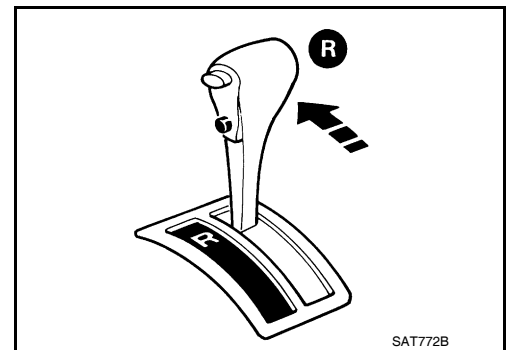

4. Turn ignition switch ON. (Do not start engine.)

Does OD OFF indicator lamp come on for about 2 seconds?

- YES >> 1. Turn ignition switch OFF.
2. Perform self-diagnosis and note NG items.
Refer to [AT-77, "CONSULT-III Function \(TRANSMISSION\)"](#), [AT-82, "Diagnosis Procedure without CONSULT-III"](#).
- NO >> Stop "Road Test". Go to [AT-180, "OD OFF Indicator Lamp Does Not Come On"](#).

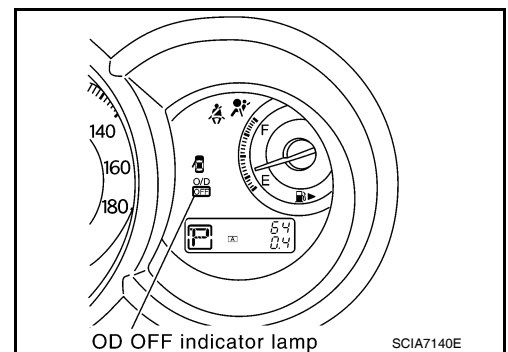

Check at Idle

INFOID:000000005928097

1.CHECK ENGINE START

1. Park vehicle on flat surface.
2. Turn ignition switch ON. (Do not start engine.)
3. Move selector lever to "P" or "N" position.
4. Turn ignition switch to "START" position.

Is engine started?

- YES >> GO TO 2.
- NO >> • Stop "Road Test". Mark the box on the "Diagnostic Worksheet Chart".
• Go to [AT-182, "Engine Cannot Be Started in "P" and "N" Position"](#).

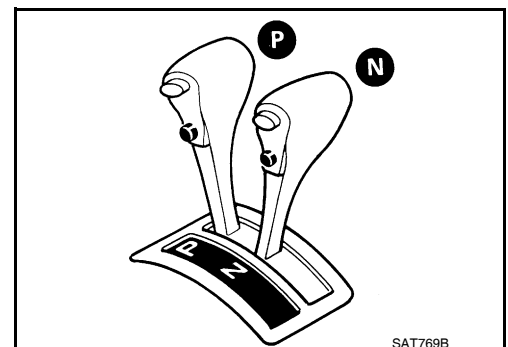

2.CHECK ENGINE START

1. Turn ignition switch ON. (Do not start engine.)

TROUBLE DIAGNOSIS

< SERVICE INFORMATION >

2. Move selector lever to "R", "D", "2" or "1" position.
3. Turn ignition switch to "START" position.

Is engine started?

- YES >> • Stop "Road Test". Mark the box on the "Diagnostic Worksheet Chart".
- Go to [AT-182. "Engine Cannot Be Started in "P" and "N" Position"](#) .
 - Continue "Road Test".
- NO >> GO TO 3.

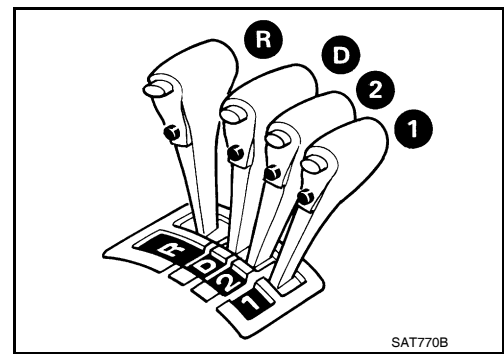

3.CHECK VEHICLE MOVE

1. Move selector lever to "P" position.
2. Turn ignition switch OFF.
3. Release parking brake.

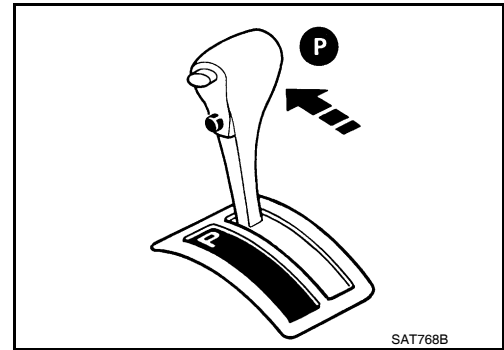

4. Push vehicle forward or backward.

Does vehicle move when it is pushed forward or backward?

- YES >> • Mark the box on the "Diagnostic Worksheet Chart".
- Go to [AT-183. "In "P" Position, Vehicle Moves Forward or Backward When Pushed"](#) .
 - Continue "Road Test".
- NO >> GO TO 4.



4.CHECK VEHICLE MOVE

1. Apply parking brake.
2. Start engine.
3. Move selector lever to "N" position.
4. Release parking brake.

Does vehicle move forward or backward?

- YES >> • Mark the box on the "Diagnostic Worksheet Chart".
- Go to [AT-183. "In "N" Position, Vehicle Moves"](#) .
 - Continue "Road Test".
- NO >> GO TO 5.

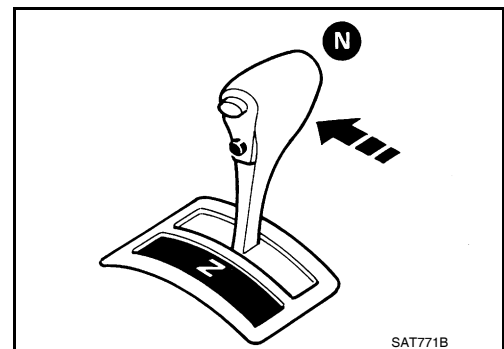

5.CHECK SHIFT SHOCK

A
B
AT
D
E
F
G
H
I
J
K
L
M
N
O
P

TROUBLE DIAGNOSIS

< SERVICE INFORMATION >

1. Apply foot brake.

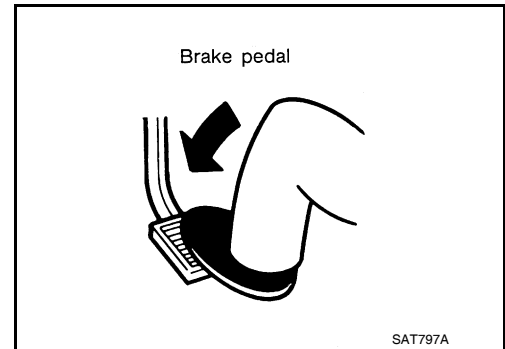

2. Move selector lever to "R" position.

Is there large shock when changing from "N" to "R" position?

- YES >> • Mark the box on the "Diagnostic Worksheet Chart".
• Go to [AT-184. "Large Shock "N" → "R" Position"](#) .
• Continue "Road Test".
- NO >> GO TO 6.

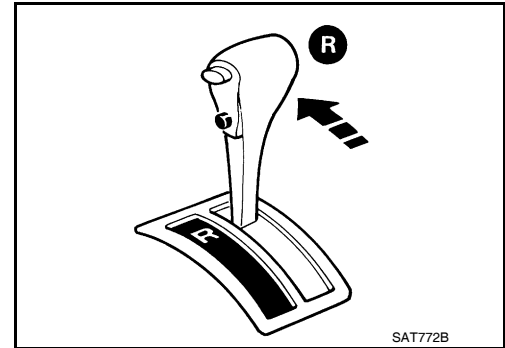

6.CHECK VEHICLE MOVE

Release foot brake for several seconds.

Does vehicle creep backward when foot brake is released?

- YES >> GO TO 7.
- NO >> • Mark the box on the "Diagnostic Worksheet Chart".
• Go to [AT-185. "Vehicle Does Not Creep Backward in "R" Position"](#) .
• Continue "Road Test".

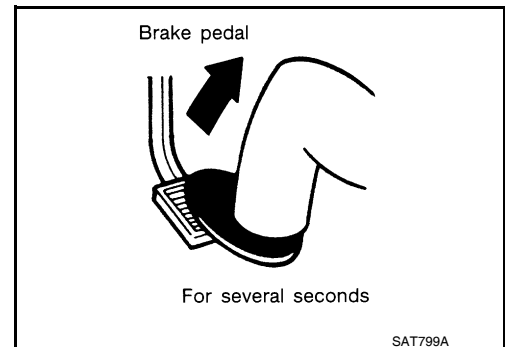

7.CHECK VEHICLE MOVE

Move selector lever to "D", "2" and "1" positions and check if vehicle creeps forward.

Does vehicle creep forward in all three positions?

- YES >> Go to [AT-58. "Cruise Test - Part 1"](#) .
- NO >> • Mark the box on the "Diagnostic Worksheet Chart".
• Go to [AT-186. "Vehicle Does Not Creep Forward in "D", "2" or "1" Position"](#) .
• Continue "Road Test".

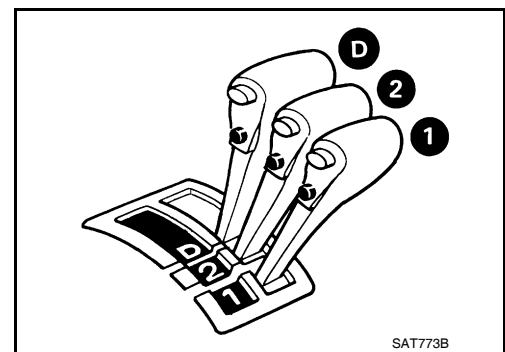

Cruise Test - Part 1

1.CHECK STARTING GEAR (D₁) POSITION

1. Drive vehicle for approximately 10 minutes to warm engine oil and ATF up to operating temperature.

ATF operating temperature: 50 - 80°C (122 - 176°F)

2. Park vehicle on flat surface.

TROUBLE DIAGNOSIS

< SERVICE INFORMATION >

3. Push overdrive control switch. (OD OFF indicator lamp is off.)
4. Move selector lever to "P" position.
5. Start engine.

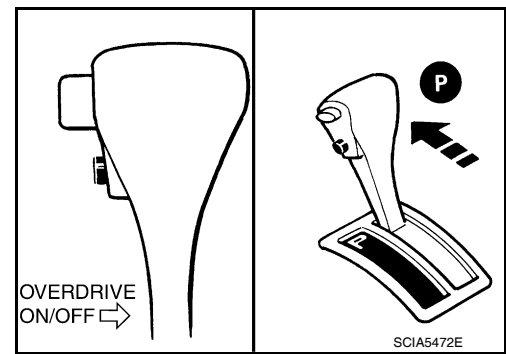

6. Move selector lever to "D" position.

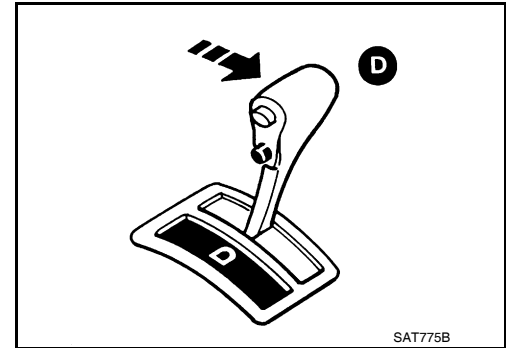

7. Accelerate vehicle by constantly depressing accelerator pedal half-way.

Ⓛ Read gear position. Refer to [AT-77, "CONSULT-III Function \(TRANSMISSION\)"](#).

Does vehicle start from D1 ?

YES >> GO TO 2.

- NO >> • Mark the box on the "Diagnostic Worksheet Chart".
 • Go to [AT-187, "Vehicle Cannot Be Started from D1"](#).
 • Continue "Road Test".

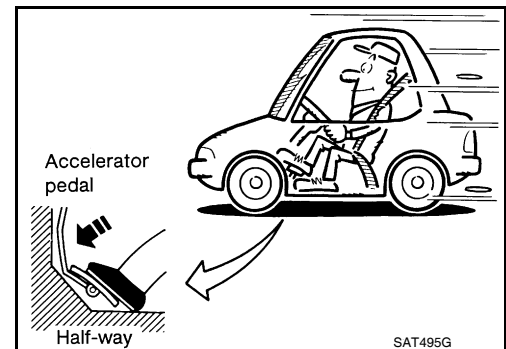

2.CHECK SHIFT-UP (D1 TO D2)

Check shift-up (D1 to D2).

Specified speed when shifting from D1 to D2. Refer to [AT-64, "Vehicle Speed at Which Gear Shifting Occurs"](#).

Ⓛ Read gear position, throttle opening and vehicle speed. Refer to [AT-77, "CONSULT-III Function \(TRANSMISSION\)"](#).

Does A/T shift from D1 to D2 at the specified speed?

YES >> GO TO 3.

- NO >> • Mark the box on the "Diagnostic Worksheet Chart".
 • Go to [AT-189, "A/T Does Not Shift: D1→ D2or Does Not Kickdown: D4→ D2"](#).
 • Continue "Road Test".

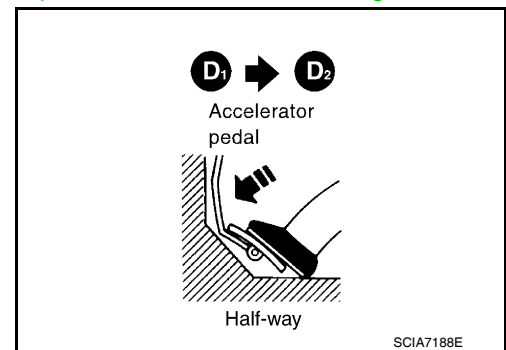

3.CHECK SHIFT-UP (D2 TO D3)

Check shift-up (D2 to D3).

Specified speed when shifting from D2 to D3. Refer to [AT-64, "Vehicle Speed at Which Gear Shifting Occurs"](#).

TROUBLE DIAGNOSIS

< SERVICE INFORMATION >

④ Read gear position, throttle opening and vehicle speed. Refer to [AT-77, "CONSULT-III Function \(TRANSMISSION\)"](#).

Does A/T shift from D2 to D3 at the specified speed?

- YES >> GO TO 4.
NO >> • Mark the box on the "Diagnostic Worksheet Chart".
• Go to [AT-190, "A/T Does Not Shift: D2→D3"](#).
• Continue "Road Test".

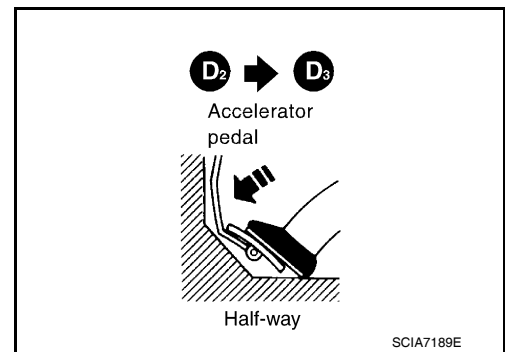

4.CHECK SHIFT-UP (D3 TO D4)

Check shift-up (D3 to D4).

Specified speed when shifting from D3 to D4. Refer to [AT-64, "Vehicle Speed at Which Gear Shifting Occurs"](#).

④ Read gear position, throttle opening and vehicle speed. Refer to [AT-77, "CONSULT-III Function \(TRANSMISSION\)"](#).

Does A/T shift from D3 to D4 at the specified speed?

- YES >> GO TO 5.
NO >> • Mark the box on the "Diagnostic Worksheet Chart".
• Go to [AT-192, "A/T Does Not Shift: D3→D4"](#).
• Continue "Road Test".

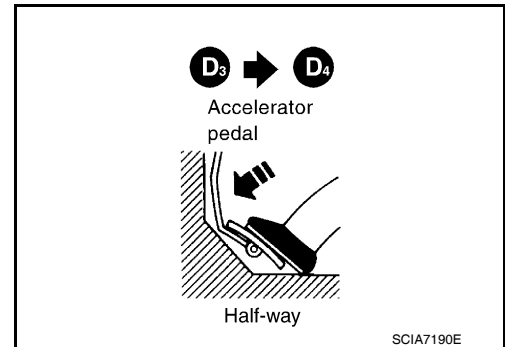

5.CHECK LOCK-UP (D4 TO D4 L/U)

Check lock-up (D4 to D4 L/U).

Specified speed when lock-up occurs. Refer to [AT-64, "Vehicle Speed at Which Lock-up Occurs/Releases"](#).

④ Read vehicle speed, throttle opening when lock-up duty becomes 94%. Refer to [AT-77, "CONSULT-III Function \(TRANSMISSION\)"](#).

Does A/T perform lock-up at the specified speed?

- YES >> GO TO 6.
NO >> • Mark the box on the "Diagnostic Worksheet Chart".
• Go to [AT-193, "A/T Does Not Perform Lock-up"](#).
• Continue "Road Test".

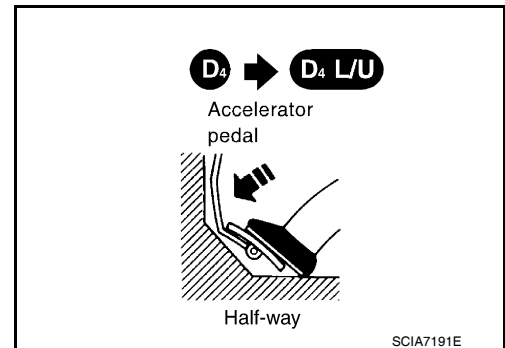

6.CHECK LOCK-UP HOLD

Check lock-up hold.

④ When lock-up duty becomes 94%. Refer to [AT-77, "CONSULT-III Function \(TRANSMISSION\)"](#).

Does A/T hold lock-up condition for more than 30 seconds?

- YES >> GO TO 7.
NO >> • Mark the box on the "Diagnostic Worksheet Chart".
• Go to [AT-194, "A/T Does Not Hold Lock-up Condition"](#).
• Continue "Road Test".

7.CHECK SHIFT-DOWN (D4 L/U TO D4)

Release accelerator pedal.

④ When lock-up duty becomes 4%. Refer to [AT-77, "CONSULT-III Function \(TRANSMISSION\)"](#).

Is lock-up released when accelerator pedal is released?

- YES >> GO TO 8.
NO >> • Mark the box on the "Diagnostic Worksheet Chart".
• Go to [AT-195, "Lock-up Is Not Released"](#).

TROUBLE DIAGNOSIS

< SERVICE INFORMATION >

- Continue "Road Test".

8. CHECK SHIFT-DOWN (D4 TO D3)

Decelerate vehicle by applying foot brake lightly.

④ **Read gear position and engine speed. Refer to AT-77, "CONSULT-III Function (TRANSMISSION)".**

Does engine speed return to idle smoothly when A/T is shifted from D4 to D3?

- YES >> 1. Stop vehicle.
2. Go to [AT-61, "Cruise Test - Part 2"](#).
- NO >> • Mark the box on the "Diagnostic Worksheet Chart".
• Go to [AT-196, "Engine Speed Does Not Return to Idle \(Light Braking D4→D3\)"](#).
• Continue "Road Test".

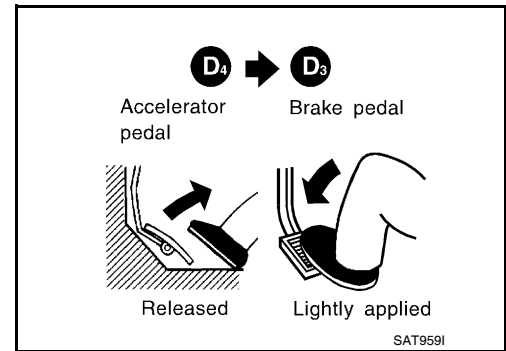

INFOID:000000005928099

Cruise Test - Part 2

1. CHECK STARTING GEAR (D1) POSITION

1. Push overdrive control switch. (OD OFF indicator lamp is off.)
2. Move selector lever to "D" position.
3. Accelerate vehicle by half throttle again.

④ **Read gear position. Refer to AT-77, "CONSULT-III Function (TRANSMISSION)".**

Does vehicle start from D1?

- YES >> GO TO 2.
- NO >> • Mark the box on the "Diagnostic Worksheet Chart".
• Go to [AT-187, "Vehicle Cannot Be Started from D1"](#).
• Continue "Road Test".

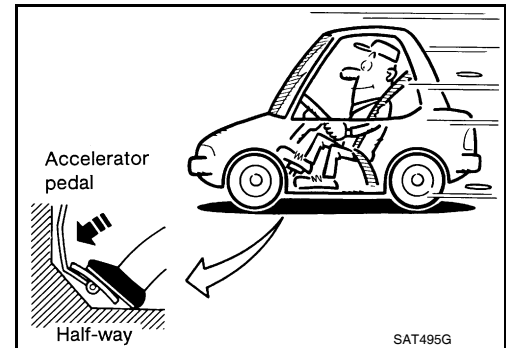

2. CHECK SHIFT-UP AND SHIFT-DOWN (D3 TO D4 TO D2)

1. Accelerate vehicle to 80 km/h (50 MPH) as shown in the figure.
2. Release accelerator pedal and then quickly depress it fully.

④ **Read gear position and throttle opening. Refer to AT-77, "CONSULT-III Function (TRANSMISSION)".**

Does A/T shift from D4 to D2 as soon as accelerator pedal is depressed fully?

- YES >> GO TO 3.
- NO >> • Mark the box on the "Diagnostic Worksheet Chart".
• Go to [AT-189, "A/T Does Not Shift: D1→D2or Does Not Kickdown: D4→D2"](#).
• Continue "Road Test".

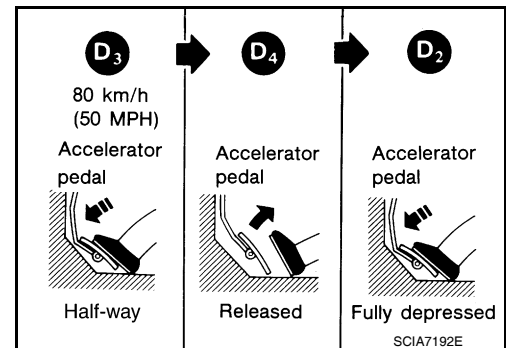

3. CHECK SHIFT-UP (D2 TO D3)

Check shift-up (D2 to D3)

Specified speed when shifting from D2 to D3. Refer to [AT-64, "Vehicle Speed at Which Gear Shifting Occurs"](#).

TROUBLE DIAGNOSIS

< SERVICE INFORMATION >

④ Read gear position, throttle opening and vehicle speed.
Refer to [AT-77, "CONSULT-III Function \(TRANSMISSION\)"](#).

Does A/T shift from D2 to D3 at the specified speed?

- YES >> GO TO 4.
NO >> • Mark the box on the "Diagnostic Worksheet Chart".
• Go to [AT-190, "A/T Does Not Shift: D2→D3"](#).
• Continue "Road Test".

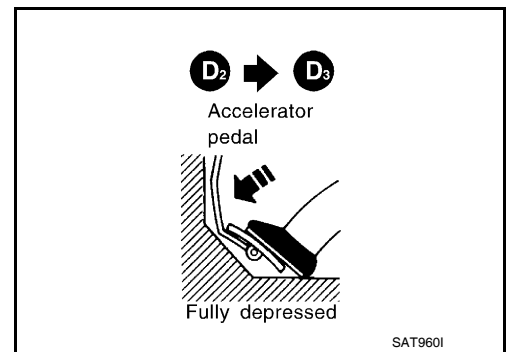

4. CHECK SHIFT-UP (D3 TO D4) AND ENGINE BRAKE

Release accelerator pedal after shifting from D2 to D3.

④ Read gear position, throttle opening and vehicle speed.
Refer to [AT-77, "CONSULT-III Function \(TRANSMISSION\)"](#).

Does A/T shift from D3 to D4 and does vehicle decelerate by engine brake?

- YES >> 1. Stop vehicle.
2. Go to [AT-62, "Cruise Test - Part 3"](#).
NO >> • Mark the box on the "Diagnostic Worksheet Chart".
• Go to [AT-192, "A/T Does Not Shift: D3→D4"](#).
• Continue "Road Test".

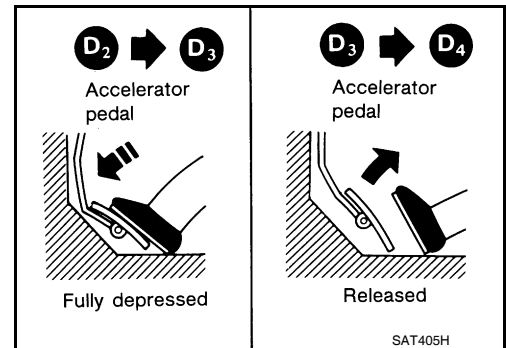

Cruise Test - Part 3

1. CHECK SHIFT-DOWN (D4 TO D3)

1. Push overdrive control switch. (OD OFF indicator lamp is off.)
2. Move selector lever to "D" position.
3. Accelerate vehicle using half throttle to D4.

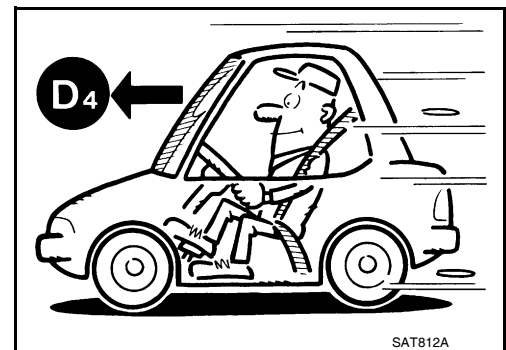

4. Release accelerator pedal.

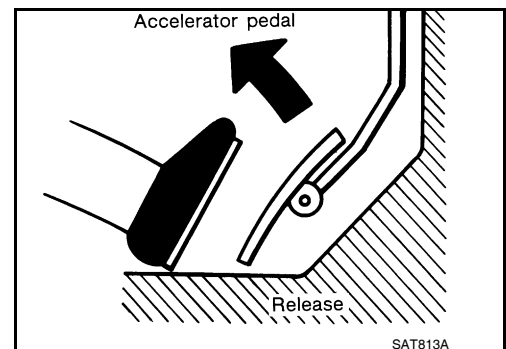

TROUBLE DIAGNOSIS

< SERVICE INFORMATION >

5. Push overdrive control switch. (OD OFF indicator lamp is on.)

④ Read gear position and vehicle speed. Refer to [AT-77, "CONSULT-III Function \(TRANSMISSION\)"](#).

Does A/T shift from D4 to D3 (OD OFF)?

YES >> GO TO 2.

- NO >>
- Mark the box on the "Diagnostic Worksheet Chart".
 - Go to [AT-197, "A/T Does Not Shift: D4→D3, When OD OFF"](#).
 - Continue "Road Test".

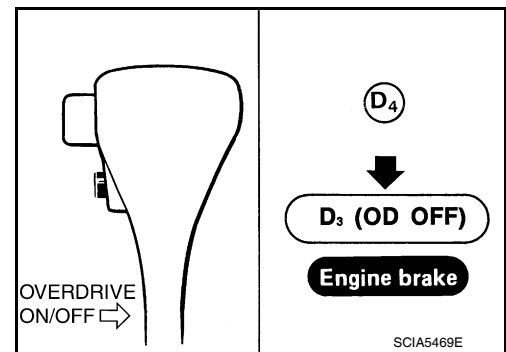

2.CHECK ENGINE BRAKE

Check engine brake.

Does vehicle decelerate by engine brake?

YES >> GO TO 3.

- NO >>
- Mark the box on the "Diagnostic Worksheet Chart".
 - Go to [AT-201, "Vehicle Does Not Decelerate by Engine Brake"](#).
 - Continue "Road Test".

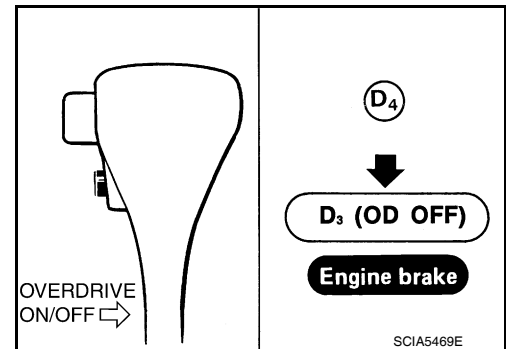

3.CHECK SHIFT-DOWN (D3 TO 2)

Move selector lever from "D" to "2" position while driving in D3 (OD OFF).

④ Read gear position. Refer to [AT-77, "CONSULT-III Function \(TRANSMISSION\)"](#).

Does A/T shift from D3 (OD OFF) to 2?

YES >> GO TO 4.

- NO >>
- Mark the box on the "Diagnostic Worksheet Chart".
 - Go to [AT-198, "A/T Does Not Shift: D3→2, When Selector Lever "D" → "2" Position"](#).
 - Continue "Road Test".

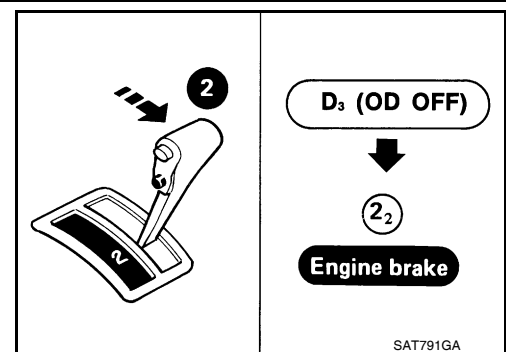

4.CHECK ENGINE BRAKE

Check engine brake.

Does vehicle decelerate by engine brake?

YES >> GO TO 5.

- NO >>
- Mark the box on the "Diagnostic Worksheet Chart".
 - Go to [AT-201, "Vehicle Does Not Decelerate by Engine Brake"](#).
 - Continue "Road Test".

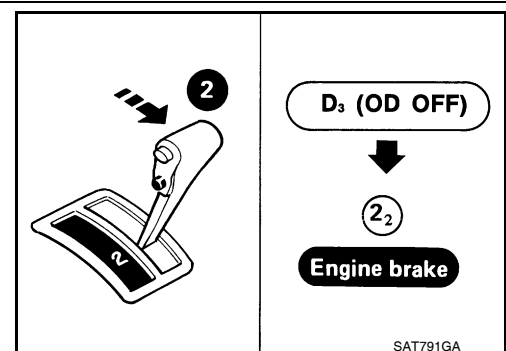

5.CHECK SHIFT-DOWN (2 TO 1)

TROUBLE DIAGNOSIS

< SERVICE INFORMATION >

Move selector lever from "2" to "1" position while driving in 22 .

Ⓟ **Read gear position. Refer to AT-77, "CONSULT-III Function (TRANSMISSION)" .**

Does A/T shift from 22 to 11 position?

YES >> GO TO 6.

- NO >> • Mark the box on the "Diagnostic Worksheet Chart".
- Go to [AT-199, "A/T Does Not Shift: 22→ 11, When Selector Lever "2" → "1" Position"](#) .
 - Continue "Road Test".

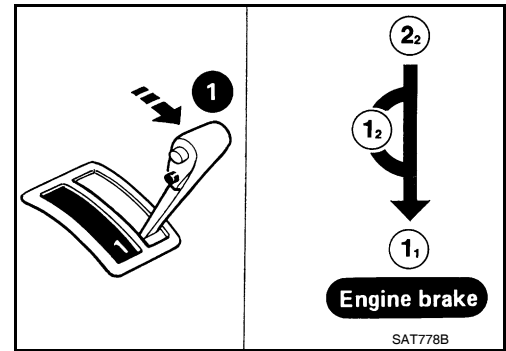

6. CHECK ENGINE BRAKE

Check engine brake.

Does vehicle decelerate by engine brake?

- YES >> 1. Stop vehicle.
2. Perform self-diagnosis. Refer to [AT-77, "CONSULT-III Function \(TRANSMISSION\)"](#) , [AT-82, "Diagnosis Procedure without CONSULT-III"](#) .
- NO >> • Mark the box on the "Diagnostic Worksheet Chart".
- Go to [AT-201, "Vehicle Does Not Decelerate by Engine Brake"](#) .
 - Stop "Road Test".

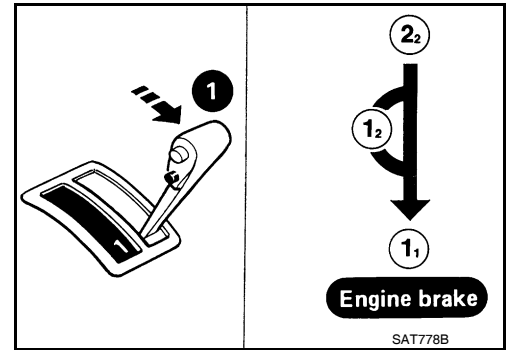

Vehicle Speed at Which Gear Shifting Occurs

INFOID:000000005928101

MR16DE engine models

Throttle position	Vehicle speed km/h (MPH)					
	D1→ D2	D2→ D3	D3→ D4	D4→ D3	D3→ D2	D2→ D1
Full throttle	49 - 57 (31 - 35)	93 - 101 (58 - 62)	148 - 156 (92 - 96)	144 - 152 (90 - 94)	82 - 90 (51 - 55)	39 - 47 (25 - 29)
Half throttle	35 - 43 (22 - 26)	59 - 67 (37 - 41)	117 - 125 (73 - 77)	59 - 67 (37 - 41)	34 - 42 (22 - 26)	15 - 23 (10 - 14)

MR18DE engine models

Throttle position	Vehicle speed km/h (MPH)					
	D1→ D2	D2→ D3	D3→ D4	D4→ D3	D3→ D2	D2→ D1
Full throttle	51 - 59 (32 - 37)	97 - 105 (60 - 65)	154 - 162 (96 - 101)	150 - 158 (93 - 98)	87 - 95 (54 - 59)	40 - 48 (25 - 30)
Half throttle	34 - 42 (21 - 26)	62 - 70 (39 - 43)	124 - 132 (77 - 82)	69 - 77 (43 - 48)	36 - 44 (22 - 27)	19 - 27 (12 - 17)

- At half throttle, the accelerator opening is 4/8 of the full opening.

Vehicle Speed at Which Lock-up Occurs/Releases

INFOID:000000005928102

MR16DE engine models

Throttle position	Selector lever position	Vehicle speed km/h (MPH)	
		Lock-up ON	Lock-up OFF
2.0/8	"D" position	73 - 81 (46 - 50)	49 - 57 (31 - 35)
	"D" position (OD OFF)	86 - 94 (53 - 58)	82 - 90 (51 - 55)

MR18DE engine models

Throttle position	Selector lever position	Vehicle speed km/h (MPH)	
		Lock-up ON	Lock-up OFF
2.0/8	"D" position	86 - 94 (53 - 58)	59 - 67 (37 - 42)
	"D" position (OD OFF)	86 - 94 (53 - 58)	83 - 91 (52 - 57)

TROUBLE DIAGNOSIS

< SERVICE INFORMATION >

Symptom Chart

INFOID:000000005928103

Numbers are arranged in order of inspection.
Perform inspections starting with number one and work up.

Items	Symptom	Condition	Diagnostic item	Reference page
No Lock-up Engage- ment/TCC Inoperative	Torque converter is not locked up.	ON vehicle	1. Accelerator pedal position sensor	EC-415 (HR16DE), EC-982 (MR18DE)
			2. Output speed sensor and vehicle speed signal	AT-100 , AT-153
			3. Engine speed signal	AT-105
			4. A/T fluid temperature sensor	AT-95
			5. Line pressure test	AT-51
			6. Torque converter clutch solenoid valve	AT-123
			7. Control valve assembly	AT-222
	OFF vehicle	8. Torque converter	AT-257	
	Torque converter clutch piston slip.	ON vehicle	1. A/T fluid level	AT-17
			2. Accelerator pedal position sensor	EC-415 (HR16DE), EC-982 (MR18DE)
			3. Line pressure test	AT-51
			4. Torque converter clutch solenoid valve	AT-123
			5. Line pressure solenoid valve	AT-133
6. Control valve assembly			AT-222	
OFF vehicle	7. Torque converter	AT-257		
Lock-up point is ex- tremely high or low.	ON vehicle	1. Accelerator pedal position sensor	EC-415 (HR16DE), EC-982 (MR18DE)	
		2. Output speed sensor and vehicle speed signal	AT-100 , AT-153	
		3. Torque converter clutch solenoid valve	AT-123	
		4. Control valve assembly	AT-222	

A
B
AT
D
E
F
G
H
I
J
K
L
M
N
O
P

TROUBLE DIAGNOSIS

< SERVICE INFORMATION >

Items	Symptom	Condition	Diagnostic item	Reference page
Shift Shock	Sharp shock in shifting from "N" to "D" position.	ON vehicle	1. Engine idling speed	EC-24 (HR16DE), EC-578 (MR18DE)
			2. Accelerator pedal position sensor	EC-415 (HR16DE), EC-982 (MR18DE)
			3. Line pressure test	AT-51
			4. A/T fluid temperature sensor	AT-95
			5. Engine speed signal	AT-105
			6. Line pressure solenoid valve	AT-133
			7. Control valve assembly	AT-222
			8. Accumulator N-D	AT-222
		OFF vehicle	9. Forward clutch	AT-307
	Shift Shock	Too sharp a shock in changing from D1 to D2 .	ON vehicle	1. Accelerator pedal position sensor
2. Line pressure test				AT-51
3. Accumulator servo release				AT-222
4. Control valve assembly				AT-222
5. A/T fluid temperature sensor				AT-95
		OFF vehicle	6. Brake band	AT-331
Shift Shock	Too sharp a shock in changing from D2 to D3 .	ON vehicle	1. Accelerator pedal position sensor	EC-415 (HR16DE), EC-982 (MR18DE)
			2. Line pressure test	AT-51
			3. Control valve assembly	AT-222
		OFF vehicle	4. High clutch	AT-302
			5. Brake band	AT-331
	Too sharp a shock in changing from D3 to D4 .	ON vehicle	1. Accelerator pedal position sensor	EC-415 (HR16DE), EC-982 (MR18DE)
			2. Line pressure test	AT-51
			3. Control valve assembly	AT-222
		OFF vehicle	4. Brake band	AT-331
			5. Overrun clutch	AT-307
			6. Forward one-way clutch	AT-318
	Gear change shock during deceleration by releasing accelerator pedal.	ON vehicle	1. Accelerator pedal position sensor	EC-415 (HR16DE), EC-982 (MR18DE)
			2. Line pressure test	AT-51
3. Overrun clutch solenoid valve			AT-148	
4. Control valve assembly			AT-222	
Large shock in changing from 12 to 11 in "1" position.	ON vehicle	1. Control valve assembly	AT-222	
	OFF vehicle	2. Low & reverse brake	AT-314	

TROUBLE DIAGNOSIS

< SERVICE INFORMATION >

Items	Symptom	Condition	Diagnostic item	Reference page
Improper Shift Timing	Too high a gear change point from D1 to D2 , from D2 to D3 , from D3 to D4 .	ON vehicle	1. Accelerator pedal position sensor	EC-415 (HR16DE), EC-982 (MR18DE)
			2. Output speed sensor and vehicle speed signal	AT-100 , AT-153
			3. Shift solenoid valve A	AT-138
			4. Shift solenoid valve B	AT-143
	Gear change directly from D1 to D3 occurs.	ON vehicle	1. A/T fluid level	AT-17
		2. Accumulator servo release	AT-222	
	OFF vehicle	3. Brake band	AT-331	
		Too high a change point from D4 to D3 , from D3 to D2 , from D2 to D1 .	ON vehicle	1. Accelerator pedal position sensor
	2. Output speed sensor and vehicle speed signal			AT-100 , AT-153
	Kickdown does not operate when depressing accelerator pedal in D4 within kickdown vehicle speed.	ON vehicle	1. Accelerator pedal position sensor	EC-415 (HR16DE), EC-982 (MR18DE)
			2. Output speed sensor and vehicle speed signal	AT-100 , AT-153
			3. Shift solenoid valve A	AT-138
			4. Shift solenoid valve B	AT-143
	Kickdown operates or engine overruns when depressing accelerator pedal in D4 beyond kickdown vehicle speed limit.	ON vehicle	1. Output speed sensor and vehicle speed signal	AT-100 , AT-153
2. Accelerator pedal position sensor			EC-415 (HR16DE), EC-982 (MR18DE)	
3. Shift solenoid valve A			AT-138	
4. Shift solenoid valve B			AT-143	
Gear change from 22 to 23 in "2" position.	ON vehicle	1. Transmission range switch adjustment	AT-225	
		2. Control cable adjustment	AT-217	
Gear change from 11 to 12 in "1" position.	ON vehicle	1. Transmission range switch adjustment	AT-225	
		2. Control cable adjustment	AT-217	

A
B
AT
D
E
F
G
H
I
J
K
L
M
N
O
P

TROUBLE DIAGNOSIS

< SERVICE INFORMATION >

Items	Symptom	Condition	Diagnostic item	Reference page
No Down Shift	Failure to change gear from D4 to D3 .	ON vehicle	1. A/T fluid level	AT-17
			2. Accelerator pedal position sensor	EC-415 (HR16DE), EC-982 (MR18DE)
			3. Overrun clutch solenoid valve	AT-148
			4. Shift solenoid valve A	AT-138
			5. Line pressure solenoid valve	AT-133
			6. Control valve assembly	AT-222
		OFF vehicle	7. Brake band	AT-331
			8. Overrun clutch	AT-307
	Failure to change gear from D3 to D2 or from D4 to D2 .	ON vehicle	1. A/T fluid level	AT-17
			2. Accelerator pedal position sensor	EC-415 (HR16DE), EC-982 (MR18DE)
			3. Shift solenoid valve A	AT-138
			4. Shift solenoid valve B	AT-143
			5. Control valve assembly	AT-222
		OFF vehicle	6. High clutch	AT-302
			7. Brake band	AT-331
	Failure to change gear from D2 to D1 or from D3 to D1 .	ON vehicle	1. A/T fluid level	AT-17
			2. Accelerator pedal position sensor	EC-415 (HR16DE), EC-982 (MR18DE)
			3. Shift solenoid valve A	AT-138
			4. Shift solenoid valve B	AT-143
			5. Control valve assembly	AT-222
		OFF vehicle	6. Low one-way clutch	AT-257
			7. High clutch	AT-302
			8. Brake band	AT-331
	Failure to change from D3 to 22 when shifting selector lever into "2" position. AT-198	ON vehicle	1. Accelerator pedal position sensor	EC-415 (HR16DE), EC-982 (MR18DE)
			2. Shift solenoid valve B	AT-143
			3. Control valve assembly	AT-222
			4. Control cable adjustment	AT-217
		OFF vehicle	5. Brake band	AT-331
Does not change from 12 to 11 in 1st position.	ON vehicle	1. Transmission range switch adjustment	AT-225	
		2. Output speed sensor and vehicle speed signal	AT-100 , AT-153	
		3. Shift solenoid valve A	AT-138	
		4. Control valve assembly	AT-222	
		5. Overrun clutch solenoid valve	AT-148	
	OFF vehicle	6. Overrun clutch	AT-307	
		7. Low & reverse brake	AT-314	

TROUBLE DIAGNOSIS

< SERVICE INFORMATION >

Items	Symptom	Condition	Diagnostic item	Reference page
No Up Shift	Failure to change gear from D1 to D2 .	ON vehicle	1. Control cable adjustment	AT-217
			2. Shift solenoid valve A	AT-138
			3. Control valve assembly	AT-222
			4. Output speed sensor and vehicle speed signal	AT-100, AT-153
			5. Accelerator pedal position sensor	EC-415 (HR16DE), EC-982 (MR18DE)
		OFF vehicle	6. Brake band	AT-331
	Failure to change gear from D2 to D3 .	ON vehicle	1. Control cable adjustment	AT-217
			2. Shift solenoid valve B	AT-143
			3. Control valve assembly	AT-222
			4. Output speed sensor and vehicle speed signal	AT-100, AT-153
			5. Accelerator pedal position sensor	EC-415 (HR16DE), EC-982 (MR18DE)
OFF vehicle		6. High clutch	AT-302	
		7. Brake band	AT-331	
Failure to change gear from D3 to D4 .	ON vehicle	1. Transmission range switch adjustment	AT-225	
		2. Overdrive control switch	AT-171	
		3. Control cable adjustment	AT-217	
		4. Shift solenoid valve A	AT-138	
		5. Output speed sensor and vehicle speed signal	AT-100, AT-153	
		6. A/T fluid temperature sensor	AT-95	
	OFF vehicle	7. Brake band	AT-331	
A/T does not shift to D4 when driving with OD ON. (OD OFF indicator lamp is off.)	ON vehicle	1. Accelerator pedal position sensor	EC-415 (HR16DE), EC-982 (MR18DE)	
		2. Transmission range switch adjustment	AT-225	
		3. Overdrive control switch	AT-171	
		4. Output speed sensor and vehicle speed signal	AT-100, AT-153	
		5. Shift solenoid valve A	AT-138	
		6. Overrun clutch solenoid valve	AT-148	
		7. Control valve assembly	AT-222	
		8. A/T fluid temperature sensor	AT-95	
		9. Line pressure solenoid valve	AT-133	
	OFF vehicle	10. Brake band	AT-331	
		11. Overrun clutch	AT-307	

A
B
AT
D
E
F
G
H
I
J
K
L
M
N
O
P

TROUBLE DIAGNOSIS

< SERVICE INFORMATION >

Items	Symptom	Condition	Diagnostic item	Reference page
Slips/Will Not Engage	Vehicle will not run in "R" position (but runs in "D", "2" and "1" positions). Clutch slips. Very poor acceleration.	ON vehicle	1. Control cable adjustment	AT-217
			2. Stall test	AT-51
			3. Line pressure test	AT-51
			4. Line pressure solenoid valve	AT-133
			5. Control valve assembly	AT-222
		OFF vehicle	6. Reverse clutch	AT-297
			7. High clutch	AT-302
			8. Forward clutch	AT-307
			9. Overrun clutch	AT-307
			10. Low & reverse brake	AT-314
	Vehicle will not run in "D" and "2" positions (but runs in "1" and "R" positions).	ON vehicle	1. Control cable adjustment	AT-217
		OFF vehicle	2. Low one-way clutch	AT-257
	Vehicle will not run in "D", "1", "2" positions (but runs in R position). Clutch slips. Very poor acceleration.	ON vehicle	1. A/T fluid level	AT-17
			2. Stall test	AT-51
			3. Line pressure test	AT-51
			4. Line pressure solenoid valve	AT-133
			5. Control valve assembly	AT-222
			6. Accumulator N-D	AT-222
		OFF vehicle	7. Reverse clutch	AT-297
			8. High clutch	AT-302
9. Forward clutch			AT-307	
10. Forward one-way clutch			AT-318	
11. Low one-way clutch			AT-257	
Clutches or brakes slip somewhat in starting.	ON vehicle	1. A/T fluid level	AT-17	
		2. Control cable adjustment	AT-217	
		3. Accelerator pedal position sensor	EC-415 (HR16DE), EC-982 (MR18DE)	
		4. Line pressure test	AT-51	
		5. Line pressure solenoid valve	AT-133	
		6. Control valve assembly	AT-222	
		7. Accumulator N-D	AT-222	
	OFF vehicle	8. Forward clutch	AT-307	
		9. Reverse clutch	AT-297	
		10. Low & reverse brake	AT-314	
		11. Oil pump	AT-278	
		12. Torque converter	AT-257	

TROUBLE DIAGNOSIS

< SERVICE INFORMATION >

Items	Symptom	Condition	Diagnostic item	Reference page	
Slips/Will Not Engage	No creep at all. AT-185 , AT-186	ON vehicle	1. A/T fluid level	AT-17	A
			2. Line pressure test	AT-51	
			3. Control valve assembly	AT-222	B
		OFF vehicle	4. Forward clutch	AT-307	
			5. Oil pump	AT-278	
			6. Torque converter	AT-257	AT
	Almost no shock or clutches slipping in change from D1 to D2 .	ON vehicle	1. A/T fluid level	AT-17	
			2. Accelerator pedal position sensor	EC-415 (HR16DE), EC-982 (MR18DE)	D
			3. Line pressure test	AT-51	
			4. Accumulator servo release	AT-222	E
			5. Control valve assembly	AT-222	
		OFF vehicle	6. Brake band	AT-331	F
	Almost no shock or slipping in changing from D2 to D3 .	ON vehicle	1. A/T fluid level	AT-17	
			2. Accelerator pedal position sensor	EC-415 (HR16DE), EC-982 (MR18DE)	G
			3. Line pressure test	AT-51	
			4. Control valve assembly	AT-222	H
		OFF vehicle	5. High clutch	AT-302	
			6. Forward clutch	AT-307	I
	Almost no shock or slipping in changing from D3 to D4 .	ON vehicle	1. A/T fluid level	AT-17	
			2. Accelerator pedal position sensor	EC-415 (HR16DE), EC-982 (MR18DE)	J
			3. Line pressure test	AT-51	
			4. Control valve assembly	AT-222	K
		OFF vehicle	5. Brake band	AT-331	
	Races extremely fast or slips in changing from D4 to D3 when depressing accelerator pedal.	ON vehicle	1. A/T fluid level	AT-17	L
2. Accelerator pedal position sensor			EC-415 (HR16DE), EC-982 (MR18DE)		
3. Line pressure test			AT-51	M	
4. Line pressure solenoid valve			AT-133		
5. Shift solenoid valve A			AT-138	N	
6. Control valve assembly			AT-222		
OFF vehicle		7. Brake band	AT-331	O	
		8. Forward clutch	AT-307	P	

TROUBLE DIAGNOSIS

< SERVICE INFORMATION >

Items	Symptom	Condition	Diagnostic item	Reference page	
Slips/Will Not Engage	Races extremely fast or slips in changing from D4 to D2 when depressing accelerator pedal.	ON vehicle	1. A/T fluid level	AT-17	
			2. Accelerator pedal position sensor	EC-415 (HR16DE), EC-982 (MR18DE)	
			3. Line pressure test	AT-51	
			4. Line pressure solenoid valve	AT-133	
			5. Shift solenoid valve A	AT-138	
			6. Shift solenoid valve B	AT-143	
			7. Control valve assembly	AT-222	
		OFF vehicle	8. Brake band	AT-331	
			9. Forward clutch	AT-307	
		Races extremely fast or slips in changing from D3 to D2 when depressing accelerator pedal.	ON vehicle	1. A/T fluid level	AT-17
				2. Accelerator pedal position sensor	EC-415 (HR16DE), EC-982 (MR18DE)
				3. Line pressure test	AT-51
				4. Line pressure solenoid valve	AT-133
	5. Shift solenoid valve B			AT-143	
	6. Control valve assembly			AT-222	
	OFF vehicle		7. Brake band	AT-331	
			8. High clutch	AT-302	
	Races extremely fast or slips in changing from D4 or D3 to D 1 when depressing accelerator pedal.	ON vehicle	1. A/T fluid level	AT-17	
			2. Accelerator pedal position sensor	EC-415 (HR16DE), EC-982 (MR18DE)	
			3. Line pressure test	AT-51	
			4. Line pressure solenoid valve	AT-133	
			5. Shift solenoid valve A	AT-138	
			6. Shift solenoid valve B	AT-143	
			7. Control valve assembly	AT-222	
		OFF vehicle	8. Forward clutch	AT-307	
			9. Forward one-way clutch	AT-318	
			10. Low one-way clutch	AT-257	
	Vehicle will not run in any position.	ON vehicle	1. A/T fluid level	AT-17	
			2. Control cable adjustment	AT-217	
3. Line pressure test			AT-51		
4. Line pressure solenoid valve			AT-133		
OFF vehicle		5. Oil pump	AT-278		
		6. High clutch	AT-302		
		7. Brake band	AT-331		
		8. Low & reverse brake	AT-314		
		9. Torque converter	AT-257		
		10. Parking components	AT-237		

TROUBLE DIAGNOSIS

< SERVICE INFORMATION >

Items	Symptom	Condition	Diagnostic item	Reference page	
Others	Engine cannot be started in "P" and "N" positions. AT-182	ON vehicle	1. Ignition switch and starter	PG-4, SC-9	A
			2. Control cable adjustment	AT-217	
			3. Transmission range switch adjustment	AT-225	B
	Engine starts in positions other than "P" and "N".	ON vehicle	1. Control cable adjustment	AT-217	
			2. Transmission range switch adjustment	AT-225	AT
	Transaxle noise in "P" and "N" positions.	ON vehicle	1. A/T fluid level	AT-17	
			2. Line pressure test	AT-51	
			3. Accelerator pedal position sensor	EC-415 (HR16DE), EC-982 (MR18DE)	D
			4. Output speed sensor and vehicle speed signal	AT-100, AT-153	E
		OFF vehicle	5. Oil pump	AT-278	
			6. Torque converter	AT-257	
	Vehicle moves when changing into "P" position or parking gear does not disengage when shifted out of "P" position.	ON vehicle	1. Control cable adjustment	AT-217	F
		OFF vehicle	2. Parking components	AT-237	G
	Vehicle runs in "N" position. AT-183	ON vehicle	1. Control cable adjustment	AT-217	
		OFF vehicle	2. Forward clutch	AT-307	H
			3. Reverse clutch	AT-297	
			4. Overrun clutch	AT-307	I
	Vehicle braked when shifting into "R" position.	ON vehicle	1. A/T fluid level	AT-17	
			2. Control cable adjustment	AT-217	J
			3. Line pressure test	AT-51	
4. Line pressure solenoid valve			AT-133		
5. Control valve assembly			AT-222	K	
OFF vehicle		6. High clutch	AT-302		
		7. Brake band	AT-331		
		8. Forward clutch	AT-307	L	
		9. Overrun clutch	AT-307		
Excessive creep.	ON vehicle	1. Engine idling speed	EC-24 (HR16DE), EC-578 (MR18DE)	M	
Engine stops when shifting lever into "R", "D", "2" and "1" positions.	ON vehicle	1. Engine idling speed	EC-24 (HR16DE), EC-578 (MR18DE)	N	
		2. A/T fluid level	AT-17		
		3. Torque converter clutch solenoid valve	AT-123		
		4. Control valve assembly	AT-222	O	
	OFF vehicle	5. Torque converter	AT-257	P	

TROUBLE DIAGNOSIS

< SERVICE INFORMATION >

Items	Symptom	Condition	Diagnostic item	Reference page
Others	Vehicle braked by gear change from D1 to D2 .	ON vehicle	1. A/T fluid level	AT-17
		OFF vehicle	2. Reverse clutch	AT-297
			3. Low & reverse brake	AT-314
			4. High clutch	AT-302
			5. Low one-way clutch	AT-257
	Vehicle braked by gear change from D2 to D3 .	ON vehicle	1. A/T fluid level	AT-17
		OFF vehicle	2. Brake band	AT-331
	Vehicle braked by gear change from D3 to D4 .	ON vehicle	1. A/T fluid level	AT-17
		OFF vehicle	2. Overrun clutch	AT-307
			3. Forward one-way clutch	AT-318
			4. Reverse clutch	AT-297
	Maximum speed not attained. Poor acceleration.	ON vehicle	1. A/T fluid level	AT-17
			2. Transmission range switch adjustment	AT-225
			3. Overdrive control switch	AT-171
			4. Accelerator pedal position sensor	EC-415 (HR16DE), EC-982 (MR18DE)
			5. Output speed sensor and vehicle speed signal	AT-100, AT-153
			6. Shift solenoid valve A	AT-138
			7. Shift solenoid valve B	AT-143
			8. Control valve assembly	AT-222
		OFF vehicle	9. Reverse clutch	AT-297
			10. High clutch	AT-302
			11. Brake band	AT-331
			12. Low & reverse brake	AT-314
13. Oil pump			AT-278	
14. Torque converter			AT-257	
Transaxle noise in "D", "2", "1" and "R" positions.	ON vehicle	1. A/T fluid level	AT-17	
	OFF vehicle	2. Torque converter	AT-257	
Engine brake does not operate in "1" position.	ON vehicle	1. Transmission range switch adjustment	AT-225	
		2. Control cable adjustment	AT-217	
		3. Output speed sensor and vehicle speed signal	AT-100, AT-153	
		4. Control valve assembly	AT-222	
		5. Overrun clutch solenoid valve	AT-148	
	OFF vehicle	6. Overrun clutch	AT-307	
		7. Low & reverse brake	AT-314	

TROUBLE DIAGNOSIS

< SERVICE INFORMATION >

Items	Symptom	Condition	Diagnostic item	Reference page
Others	Transaxle overheats.	ON vehicle	1. A/T fluid level	AT-17
			2. Engine idling speed	EC-24 (HR16DE), EC-578 (MR18DE)
			3. Accelerator pedal position sensor	EC-415 (HR16DE), EC-982 (MR18DE)
			4. Line pressure test	AT-51
			5. Line pressure solenoid valve	AT-133
			6. Control valve assembly	AT-222
		OFF vehicle	7. Oil pump	AT-278
			8. Reverse clutch	AT-297
			9. High clutch	AT-302
			10. Brake band	AT-331
			11. Forward clutch	AT-307
			12. Overrun clutch	AT-307
			13. Low & reverse brake	AT-314
			14. Torque converter	AT-257
	ATF shoots out during operation. White smoke emitted from exhaust pipe during operation.	ON vehicle	1. A/T fluid level	AT-17
		OFF vehicle	2. Reverse clutch	AT-297
			3. High clutch	AT-302
			4. Brake band	AT-331
			5. Forward clutch	AT-307
			6. Overrun clutch	AT-307
			7. Low & reverse brake	AT-314
	Unusual smell at A/T fluid charging pipe.	ON vehicle	1. A/T fluid level	AT-17
		OFF vehicle	2. Torque converter	AT-257
			3. Oil pump	AT-278
			4. Reverse clutch	AT-297
			5. High clutch	AT-302
			6. Brake band	AT-331
7. Forward clutch			AT-307	
8. Overrun clutch			AT-307	
9. Low & reverse brake			AT-314	

TCM Terminal and Reference Value

INFOID:000000005928104

TCM HARNESS CONNECTOR TERMINAL LAYOUT

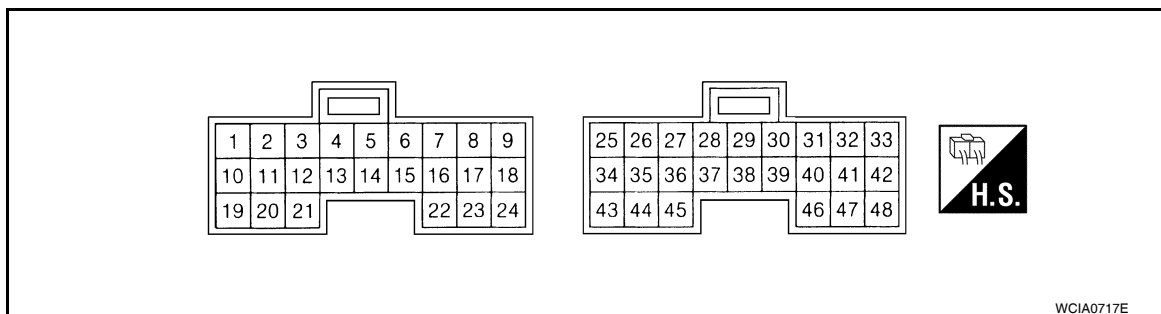









Terminals and Reference Values for TCM

TROUBLE DIAGNOSIS

< SERVICE INFORMATION >

TCM terminal data are reference values, measured between each terminal and ground.

Terminal	Wire color	Item	Condition		Judgement standard (Approx.)
1	W	Line pressure solenoid valve		When releasing accelerator pedal after warming up engine.	1.5 - 3.0 V
				When depressing accelerator pedal fully after warming up engine.	0 V
2	P	Line pressure solenoid valve (with dropping resistor)		When releasing accelerator pedal after warming up engine.	4 - 14 V
				When depressing accelerator pedal fully after warming up engine.	0 V
3	GR	Torque converter clutch solenoid valve		When A/T performs lock-up.	8 - 15 V
				When A/T does not perform lock-up.	0 V
5	L	CAN H	—		—
6	P	CAN L	—		—
10	R	Power supply	When turning ignition switch to "ON".		Battery voltage
			When turning ignition switch to "OFF".		0 V
11	O	Shift solenoid valve A		When shift solenoid valve A operates. (When driving in "D1" or "D4".)	Battery voltage
				When shift solenoid valve A does not operate. (When driving in "D2" or "D3".)	0 V
12	G	Shift solenoid valve B		When shift solenoid valve B operates. (When driving in "D1" or "D2".)	Battery voltage
				When shift solenoid valve B does not operate. (When driving in "D3" or "D4".)	0 V
19	R	Power supply	When turning ignition switch to "ON".		Battery voltage
			When turning ignition switch to "OFF".		0 V
20	V	Overrun clutch solenoid valve		When overrun clutch solenoid valve operates. (When overrun clutch disengaged. Refer to AT-22 .)	Battery voltage
				When overrun clutch solenoid valve does not operate. (When overrun clutch engaged. Refer to AT-22 .)	0 V
25	B	Ground	Always		0 V
26	Y	Transmission range switch "1" position		When setting selector lever to "1" position.	Battery voltage
				When setting selector lever to other positions.	0 V
27	G	Transmission range switch "2" position	and 	When setting selector lever to "2" position.	Battery voltage
				When setting selector lever to other positions.	0 V
28	GR	Power supply (memory back-up)	Always		Battery voltage
29	V	Output speed sensor		When driving at 20 km/h (12 MPH)	150 Hz
30*1	BR	CONSULT- III (RX)	—		—
31*1	Y	CONSULT- III (TX)	—		—

TROUBLE DIAGNOSIS

< SERVICE INFORMATION >

Terminal	Wire color	Item	Condition	Judgement standard (Approx.)
34	LG	Transmission range switch "D" position	When setting selector lever to "D" position.	Battery voltage
			When setting selector lever to other positions.	0 V
35	SB	Transmission range switch "R" position	When setting selector lever to "R" position.	Battery voltage
			When setting selector lever to other positions.	0 V
36	R	Transmission range switch "N" or "P" position	When setting selector lever to "N" or "P" position.	Battery voltage
			When setting selector lever to other positions.	0 V
38	G	Input speed sensor	When driving at 20 km/h (12 MPH)	360 Hz
39 ^{*2}	L	Engine speed signal	Refer to EC-464 (HR16DE), EC-605 (MR18DE).	
40	O	Vehicle speed signal	When driving vehicle at 2 to 3 km/h (1 to 2 MPH) for 1 m (3 ft) or more.	Voltage varies between less than 0 V and more than 4.5 V
42	B	Sensor ground	Always	0 V
47	BR	A/T fluid temperature sensor	When A/T fluid temperature is 20°C (68°F).	1.5 V
			When A/T fluid temperature is 80°C (176°F).	0.5 V
48	B	Ground	Always	0 V

*1: These terminals are connected to the data link connector.

*2: These terminals are connected to the ECM.

CONSULT-III Function (TRANSMISSION)

INFOID:0000000005928105

CONSULT-III can display each diagnostic item using the diagnostic test models shown following.

FUNCTION

Diagnostic test mode	Function
Work Support	This mode enables a technician to adjust some devices faster and more accurately.
Self Diagnostic Results	Retrieve DTC from ECU and display diagnostic items.
Data Monitor	Monitor the input/output signal of the control unit in real time.
CAN Diagnosis Support Monitor	It monitors the status of CAN communication.
Function Test	This mode can show results of self-diagnosis of ECU with either "OK" or "NG". For engine, more practical tests regarding sensors/switches and/or actuators are available.
DTC & SRT confirmation	The status of system monitoring tests and the self-diagnosis status/result can be confirmed.
ECU Identification	Display the ECU identification number (part number etc.) of the selected system.

CONSULT-III REFERENCE VALUE

NOTICE:

- The CONSULT-III electrically displays shift timing and lock-up timing (that is, operation timing of each solenoid).

TROUBLE DIAGNOSIS

< SERVICE INFORMATION >

Check for time difference between actual shift timing and the CONSULT-III display. If the difference is noticeable, mechanical parts (except solenoids, sensors, etc.) may be malfunctioning. Check mechanical parts using applicable diagnostic procedures.

2. Shift schedule (which implies gear position) displayed on CONSULT-III and that indicated in Service Manual may differ slightly. This occurs because of the following reasons:
 - Actual shift schedule has more or less tolerance or allowance,
 - Shift schedule indicated in Service Manual refers to the point where shifts start, and
 - Gear position displayed on CONSULT-III indicates the point where shifts are completed.
3. Shift solenoid valve "A" or "B" is displayed on CONSULT-III at the start of shifting. Gear position is displayed upon completion of shifting (which is computed by TCM).

Item name	Condition	Display value (Approx.)
VHCL/S SE-A/T	During driving	Approximately matches the speedometer reading.
VHCL/S SE-MTR		
THROTTLE POSI	Released accelerator pedal.	0.0/8
	Fully depressed accelerator pedal.	8.0/8
FLUID TEMP SE	When A/T fluid temperature is 20°C (68°F).	1.5 V
	When A/T fluid temperature is 80°C (176°F).	0.5 V
BATTERY VOLT	When turning ignition switch to "ON".	Battery voltage
ENGINE SPEED	Engine running	Approximately matches the tachometer reading.
INPUT SPEED	During driving (lock-up ON)	Approximately matches the engine speed.
OVERDRIVE SW	When overdrive control switch is depressed.	ON
	When overdrive control switch is released.	OFF
PN POSI SW	When setting selector lever to "N" or "P" position.	ON
	When setting selector lever to other positions.	OFF
R POSITION SW	When setting selector lever to "R" position.	ON
	When setting selector lever to other positions.	OFF
D POSITION SW	When setting selector lever to "D" position.	ON
	When setting selector lever to other positions.	OFF
2 POSITION SW	When setting selector lever to "2" position.	ON
	When setting selector lever to other positions.	OFF
1 POSITION SW	When setting selector lever to "1" position.	ON
	When setting selector lever to other positions.	OFF
CLOSED THL/SW	Released accelerator pedal.	ON
	Depressed accelerator pedal.	OFF
W/O THRL/P-SW	Fully depressed accelerator pedal.	ON
	Released accelerator pedal.	OFF
SHIFT S/V A	When shift solenoid valve A operates. (When driving in "D1" or "D4".)	ON
	When shift solenoid valve A does not operate. (When driving in "D2" or "D3".)	OFF
SHIFT S/V B	When shift solenoid valve B operates. (When driving in "D1" or "D2".)	ON
	When shift solenoid valve B does not operate. (When driving in "D3" or "D4".)	OFF

TROUBLE DIAGNOSIS

< SERVICE INFORMATION >

Item name	Condition	Display value (Approx.)
OVERRUN/C S/V	When overrun clutch solenoid valve operates. (When overrun clutch disengaged. Refer to AT-22 .)	ON
	When overrun clutch solenoid valve does not operate. (When overrun clutch engaged. Refer to AT-22 .)	OFF
BRAKE SW	Depressed brake pedal.	ON
	Released brake pedal.	OFF
GEAR	During driving	1, 2, 3, 4
SLCT LVR POSI	When setting selector lever to "N" or "P" positions.	N · P
	When setting selector lever to "R" position.	R
	When setting selector lever to "D" position.	D
	When setting selector lever to "2" position.	2
	When setting selector lever to "1" position.	1
VEHICLE SPEED	During driving	Approximately matches the speedometer reading.
LINE PRES DTY	Line pressure low ↔ Line pressure high	0 % ↔ 94 %
TCC S/V DUTY	Lock-up OFF ↔ Lock-up ON	4 % ↔ 94 %

SELF-DIAGNOSTIC RESULT MODE

Display Items List

Items (CONSULT-III screen terms)	Malfunction is detected when...	OBD-II (DTC)	Reference page
		MIL indicator lamp*1, "ENGINE" with CONSULT-III or GST	
CAN COMM CIRCUIT	• When TCM is not transmitting or receiving CAN communication signal for 2 seconds or more.	U1000	AT-87
T/M RANGE SENSOR A	• TCM does not receive the correct voltage signal (based on the gear position) from the switch.	P0705	AT-90
FLUID TEMP SENSOR A	• TCM receives an excessively low or high voltage from the sensor.	P0710	AT-95
OUTPUT SPEED SENSOR	• TCM does not receive the proper voltage signal from the sensor.	P0720	AT-100
ENGINE SPEED	• TCM does not receive the proper voltage signal from the ECM.	P0725	AT-105
1GR INCORRECT RATIO	• A/T cannot be shifted to the 1GR position even if electrical circuit is good.	P0731*2	AT-109
2GR INCORRECT RATIO	• A/T cannot be shifted to the 2GR position even if electrical circuit is good.	P0732*2	AT-112
3GR INCORRECT RATIO	• A/T cannot be shifted to the 3GR position even if electrical circuit is good.	P0733*2	AT-115
4GR INCORRECT RATIO	• A/T cannot be shifted to the 4GR position even if electrical circuit is good.	P0734*2	AT-118
TORQUE CONVERTER	• TCM detects an improper voltage drop when it tries to operate the solenoid valve.	P0740	AT-123
TORQUE CONVERTER	• A/T cannot perform lock-up even if electrical circuit is good.	P0744*2	AT-128
PC SOLENOID A	• TCM detects an improper voltage drop when it tries to operate the solenoid valve.	P0745	AT-133

TROUBLE DIAGNOSIS

< SERVICE INFORMATION >

Items (CONSULT-III screen terms)	Malfunction is detected when...	OBD-II (DTC)	Reference page
		MIL indicator lamp*1, "ENGINE" with CONSULT-III or GST	
SHIFT SOLENOID A	• TCM detects an improper voltage drop when it tries to operate the solenoid valve.	P0750	AT-138
SHIFT SOLENOID B	• TCM detects an improper voltage drop when it tries to operate the solenoid valve.	P0755	AT-143
OVER CLUTCH SOLENOID	• TCM detects an improper voltage drop when it tries to operate the solenoid valve.	P1760	AT-148
VHCL SPEED SENSOR	• TCM does not receive the proper voltage signal from the sensor.	—	AT-153
BATT/FLUID TEMP SEN	• TCM receives an excessively low or high voltage from the sensor.	—	AT-156
INPUT SPEED SENSOR A	• TCM does not receive proper voltage signal from sensor.	—	AT-162
CONTROL UNIT (RAM)	• TCM memory (RAM) is malfunctioning.	—	AT-167
CONTROL UNIT (ROM)	• TCM memory (ROM) is malfunctioning.	—	AT-167
No failure (NO SELF DIAGNOSTIC FAILURE INDICATED FURTHER TESTING MAY BE REQUIRED)	• No failure has been detected.	—	—

*1: Refer to [AT-41, "Malfunction Indicator Lamp \(MIL\)"](#).

*2: These malfunctions cannot be displayed MIL if another malfunction is assigned to MIL.

DATA MONITOR MODE

Display Items List

X: Standard, —: Not applicable, ▼: Option

Monitored item (Unit)	Monitor Item Selection			Remarks
	TCM INPUT SIGNALS	MAIN SIGNALS	SELECTION FROM MENU	
VHCL/S SE-A/T (km/h)	X	—	▼	Output speed sensor
VHCL/S SE-MTR (km/h)	X	—	▼	Vehicle speed display may not be accurate under approx. 10 km/h (6 mph). It may not indicate 0 km/h (0 mph) when vehicle is stationary.
THRTL POS SEN (V)	X	—	▼	
FLUID TEMP SE (V)	X	—	▼	
BATTERY VOLT (V)	X	—	▼	
ENGINE SPEED (rpm)	X	X	▼	
INPUT SPEED (rpm)	X	—	▼	
OVERDRIVE SW (ON/OFF)	X	—	▼	
PN POSI SW (ON/OFF)	X	—	▼	
R POSITION SW (ON/OFF)	X	—	▼	
D POSITION SW (ON/OFF)	X	—	▼	

TROUBLE DIAGNOSIS

< SERVICE INFORMATION >

Monitored item (Unit)	Monitor Item Selection			Remarks	
	TCM INPUT SIGNALS	MAIN SIGNALS	SELECTION FROM MENU		
2 POSITION SW (ON/OFF)	X	—	▼		A
1 POSITION SW (ON/OFF)	X	—	▼		B
ASCD-CRUISE (ON/OFF)	X	—	▼	Signal input with CAN communication.	AT
ASCD-OD CUT (ON/OFF)	X	—	▼		
KICKDOWN SW (ON/OFF)	X	—	▼	Not mounted but displayed.	D
POWERSHIFT SW (ON/OFF)	X	—	▼		
CLOSED THL/SW (ON/OFF)	X	—	▼	Signal input with CAN communication.	E
W/O THRL/P-SW (ON/OFF)	X	—	▼		
*SHIFT S/V A (ON/OFF)	—	—	▼	Displays status of check signal (reinput signal) for TCM control signal output. Remains unchanged when solenoid valves are open or shorted.	F
*SHIFT S/V B (ON/OFF)	—	—	▼		
*OVERRUN/C S/V (ON/OFF)	—	—	▼		
HOLD SW (ON/OFF)	X	—	▼	Not mounted but displayed.	G
BRAKE SW (ON/OFF)	X	—	▼	Stop lamp switch (Signal input with CAN communication)	H
GEAR	—	X	▼	Gear position recognized by the TCM updated after gear-shifting	I
SLCT LVR POSI	—	X	▼	Selector lever position is recognized by the TCM. For fail-safe operation, the specific value used for control is displayed.	J
VEHICLE SPEED (km/h)	—	X	▼	Vehicle speed recognized by the TCM.	K
THROTTLE POSI (0.0/8)	—	X	▼	Degree of opening for accelerator recognized by the TCM For fail-safe operation, the specific value used for control is displayed.	L
LINE PRES DTY (%)	—	X	▼		M
TCC S/V DUTY (%)	—	X	▼		N
SHIFT S/V A (ON/OFF)	—	X	▼		O
SHIFT S/V B (ON/OFF)	—	X	▼		P
OVERRUN/C S/V (ON/OFF)	—	X	▼		
SELF-D DP LMP (ON/OFF)	—	X	▼		
TC SLIP RATIO (0.000)	—	—	▼		
TC SLIP SPEED (rpm)	—	—	▼	Difference between engine speed and torque converter input shaft speed	

CAN DIAGNOSTIC SUPPORT MONITOR MODE

Refer to [LAN-14, "CAN Diagnostic Support Monitor"](#).

DTC & SRT CONFIRMATION

Display Items List

TROUBLE DIAGNOSIS

< SERVICE INFORMATION >

DTC work support item	Description	Check item
1ST GR FNCTN P0731	Following items for "1GR incorrect ratio (P0731)" can be confirmed. <ul style="list-style-type: none"> Self-diagnosis status (whether the diagnosis is being performed or not) Self-diagnostic results (OK or NG) 	<ul style="list-style-type: none"> Shift solenoid valve A Shift solenoid valve B Each clutch Hydraulic control circuit
2ND GR FNCTN P0732	Following items for "2GR incorrect ratio (P0732)" can be confirmed. <ul style="list-style-type: none"> Self-diagnosis status (whether the diagnosis is being performed or not) Self-diagnostic results (OK or NG) 	<ul style="list-style-type: none"> Shift solenoid valve B Each clutch Hydraulic control circuit
3RD GR FNCTN P0733	Following items for "3GR incorrect ratio (P0733)" can be confirmed. <ul style="list-style-type: none"> Self-diagnosis status (whether the diagnosis is being performed or not) Self-diagnostic results (OK or NG) 	<ul style="list-style-type: none"> Shift solenoid valve A Each clutch Hydraulic control circuit
4TH GR FNCTN P0734	Following items for "4GR incorrect ratio (P0734)" can be confirmed. <ul style="list-style-type: none"> Self-diagnosis status (whether the diagnosis is being performed or not) Self-diagnostic results (OK or NG) 	<ul style="list-style-type: none"> Shift solenoid valve A Shift solenoid valve B Overrun clutch solenoid valve Line pressure solenoid valve Each clutch Hydraulic control circuit
TCC S/V FNCTN P0744	Following items for "Torque converter (P0744)" can be confirmed. <ul style="list-style-type: none"> Self-diagnosis status (whether the diagnosis is being performed or not) Self-diagnostic results (OK or NG) 	<ul style="list-style-type: none"> Torque converter clutch solenoid valve Each clutch Hydraulic control circuit

Diagnosis Procedure without CONSULT-III

INFOID:000000005928106

⊗ TCM SELF-DIAGNOSTIC PROCEDURE

Description

If a malfunction occurs in electrical system, turning ignition switch ON will illuminate OD OFF indicator lamp for 2 seconds. To detect a malfunction, entering a self-diagnosis start signal retrieves information on malfunctions from memory and indicates malfunction by blinking OD OFF indicator lamp.

Diagnostic Procedure

1. CHECK OD OFF INDICATOR LAMP

1. Park vehicle on flat surface.
2. Move selector lever to "P" position.
3. Turn ignition switch OFF. Wait at least 5 seconds.

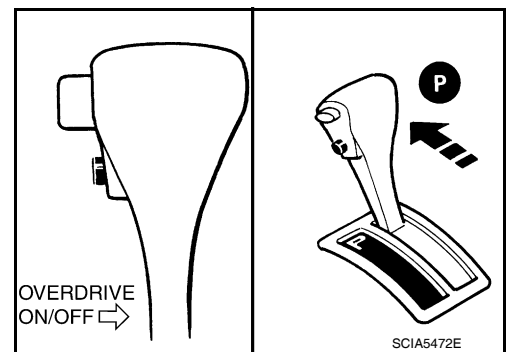

TROUBLE DIAGNOSIS

< SERVICE INFORMATION >

4. Turn ignition switch ON. (Do not start engine.)

Does OD OFF indicator lamp come on about 2 seconds?

YES >> GO TO 2.

NO >> Stop procedure. Perform [AT-180. "OD OFF Indicator Lamp Does Not Come On"](#) before proceeding.

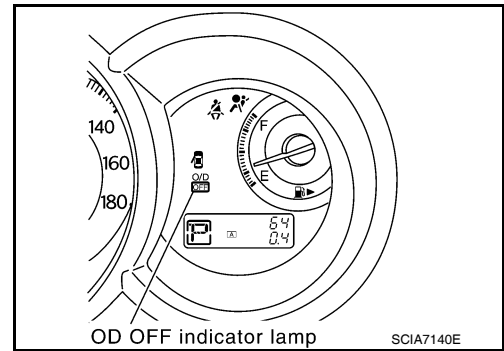

2. JUDGEMENT PROCEDURE STEP 1

1. Turn ignition switch OFF.
2. Keep pressing shift lock release button.
3. Move selector lever from "P" to "D" position.
4. Turn ignition switch ON. (Do not start engine.)
5. Keep pressing overdrive control switch while OD OFF indicator lamp is lighting up for 2 seconds. (OD OFF indicator lamp is on.)
6. Keep pressing overdrive control switch and shift selector lever to the "2" position. (OD OFF indicator lamp is on.)
7. Stop pressing overdrive control switch. (OD OFF indicator lamp is on.)
8. Shift selector lever to the "1" position. (OD OFF indicator lamp is on.)
9. Keep pressing overdrive control switch. (OD OFF indicator lamp is off.)
10. Depress accelerator pedal fully while pressing overdrive control switch.

>> GO TO 3.

3. CHECK SELF-DIAGNOSIS CODE

Check OD OFF indicator lamp. Refer to "Judgement of Self-diagnosis Code".

>> **DIAGNOSIS END**

Judgement of Self-diagnosis Code

TROUBLE DIAGNOSIS

< SERVICE INFORMATION >

OD OFF indicator lamp

All judgement flickers are the same.

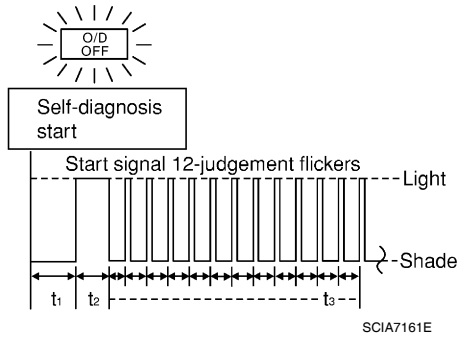

All circuits that can be confirmed by self-diagnosis are OK.

1st judgement flicker is longer than others.

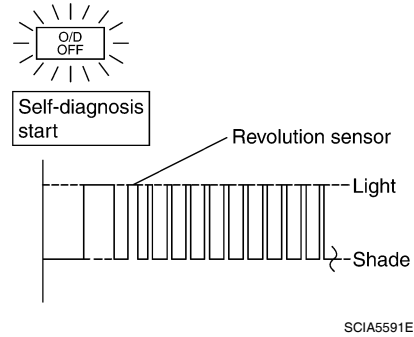

Output speed sensor circuit is short-circuited or disconnected.
⇒ Go to **AT-100**.

2nd judgement flicker is longer than others.

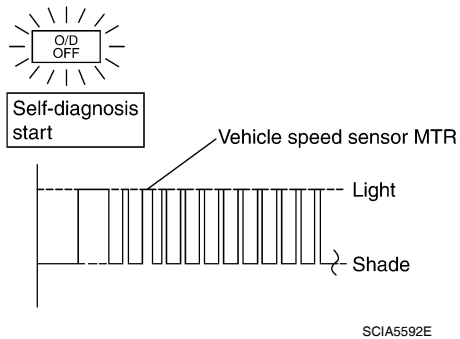

Vehicle speed signal circuit is short-circuited or disconnected.
⇒ Go to **AT-153**.

4th judgement flicker is longer than others.

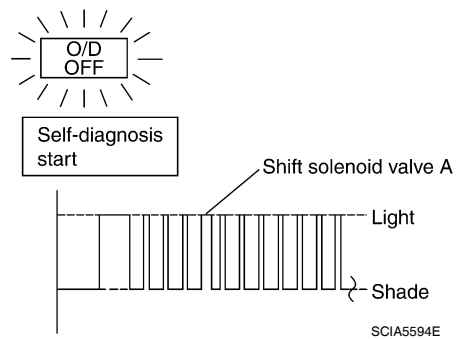

Shift solenoid valve A circuit is short-circuited or disconnected.
⇒ Go to **AT-138**.

5th judgement flicker is longer than others.

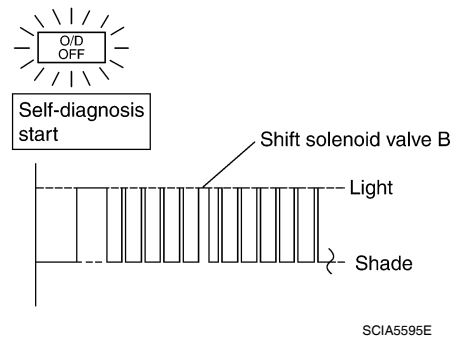

Shift solenoid valve B circuit is short-circuited or disconnected.
⇒ Go to **AT-143**.

6th judgement flicker is longer than others.

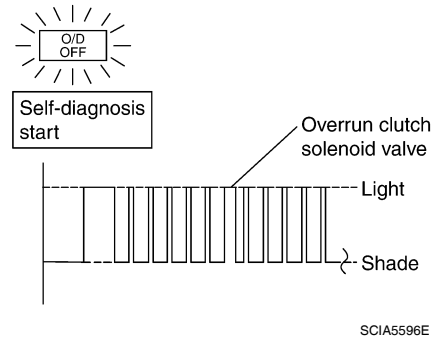

Overrun clutch solenoid valve circuit is short-circuited or disconnected.
⇒ Go to **AT-148**.

TROUBLE DIAGNOSIS

< SERVICE INFORMATION >

OD OFF indicator lamp

7th judgement flicker is longer than others.

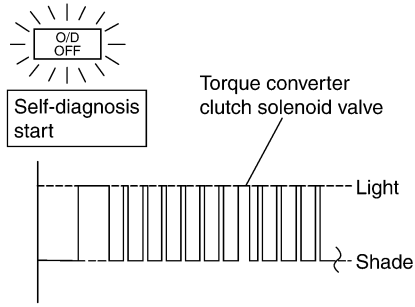

SCIA5597E

Torque converter clutch solenoid valve circuit is short-circuited or disconnected.

⇒ Go to [AT-123](#).

8th judgement flicker is longer than others.

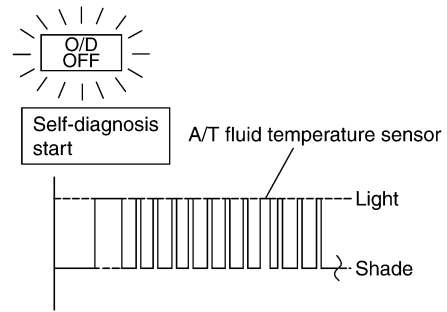

SCIA5598E

A/T fluid temperature sensor is disconnected or TCM power supply circuit is damaged.

⇒ Go to [AT-156](#).

9th judgement flicker is longer than others.

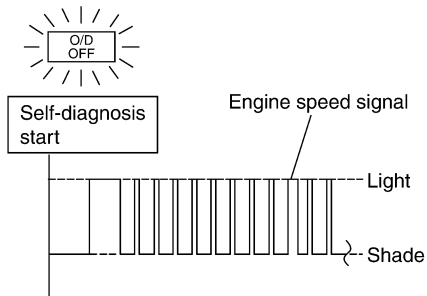

SCIA5599E

Engine speed signal circuit is short-circuited or disconnected.

⇒ Go to [AT-105](#).

10th judgement flicker is longer than others.

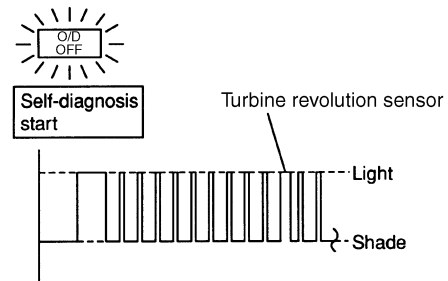

SCIA7082E

Input speed sensor circuit is short-circuited or disconnected.

⇒ Go to [AT-162](#).

A
B
AT
D
E
F
G
H
I
J
K
L
M
N
O
P

TROUBLE DIAGNOSIS

< SERVICE INFORMATION >

OD OFF indicator lamp

11th judgement flicker is longer than others.

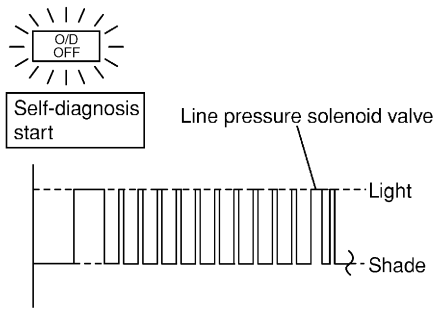

SCIA7083E

Line pressure solenoid valve circuit is short-circuited or disconnected.

⇒ Go to **AT-133**.

12th judgement flicker is longer than others.

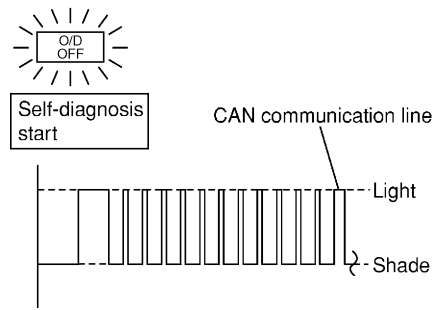

SCIA7085E

CAN communication line is damaged.

⇒ Go to **AT-87**.

Lamp turns off.

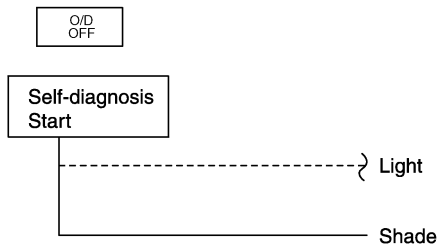

SCIA4674E

Transmission range switch, overdrive control switch, closed throttle position signal or wide open throttle position signal circuit is disconnected or TCM is damaged.

(Because overdrive control switch signal, closed throttle position signal and wide open throttle position signal are input via CAN communication line malfunction may continue after self-diagnosis.)

⇒ Go to **AT-204, "TCM Self-Diagnosis Does Not Activate"**.

t1 = 2.5 seconds t2 = 2.0 seconds t3 = 1.0 second

How to Erase Self-diagnostic Results

1. If the ignition switch stays ON after repair work, be sure to turn ignition switch OFF once. Wait for at least 5 seconds and then turn it ON again.
2. Perform "Diagnostic Procedure Without CONSULT-III".
3. Turn ignition switch OFF. (The self-diagnostic results will be erased.)

U1000 CAN COMM CIRCUIT

< SERVICE INFORMATION >

U1000 CAN COMM CIRCUIT

Description

INFOID:000000005928107

CAN (Controller Area Network) is a serial communication line for real time application. It is an on-vehicle multiplex communication line with high data communication speed and excellent malfunction detection ability. Many electronic control units are equipped onto a vehicle, and each control unit shares information and links with other control units during operation (not independent). In CAN communication, control units are connected with 2 communication lines (CAN H line, CAN L line) allowing a high rate of information transmission with less wiring. Each control unit transmits/receives data but selectively reads required data only.

On Board Diagnosis Logic

INFOID:000000005928108

- This is an OBD-II self-diagnostic item.
- Diagnostic trouble code "U1000 CAN COMM CIRCUIT" with CONSULT-III or 12th judgement flicker without CONSULT-III is detected when TCM cannot communicate to other control units.

Possible Cause

INFOID:000000005928109

Harness or connector
(CAN communication line is open or shorted.)

DTC Confirmation Procedure

INFOID:000000005928110

CAUTION:

If performing this "DTC Confirmation Procedure" again, always turn ignition switch OFF and wait at least 10 seconds before continuing.

After the repair, perform the following procedure to confirm the malfunction is eliminated.

WITH CONSULT-III

1. Turn ignition switch ON.
2. Select "DATA MONITOR" mode for "TRANSMISSION" with CONSULT-III.
3. Touch "START".
4. Wait at least 6 seconds or start engine and wait for at least 6 seconds.
5. If DTC is detected, go to [AT-89. "Diagnosis Procedure"](#).

WITH GST

Follow the procedure "WITH CONSULT-III".

WITHOUT CONSULT-III

1. Turn ignition switch ON.
2. Wait at least 6 seconds or start engine and wait at least 6 seconds.
3. Perform self-diagnosis. Refer to [AT-82. "Diagnosis Procedure without CONSULT-III"](#).
4. If DTC is detected, go to [AT-89. "Diagnosis Procedure"](#).



U1000 CAN COMM CIRCUIT

< SERVICE INFORMATION >

Wiring Diagram - AT - CAN

INFOID:000000005928111

AT-CAN-01

-  : DETECTABLE LINE FOR DTC
-  : NON-DETECTABLE LINE FOR DTC
-  : DATA LINE

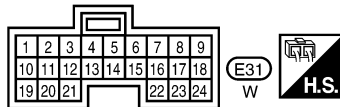
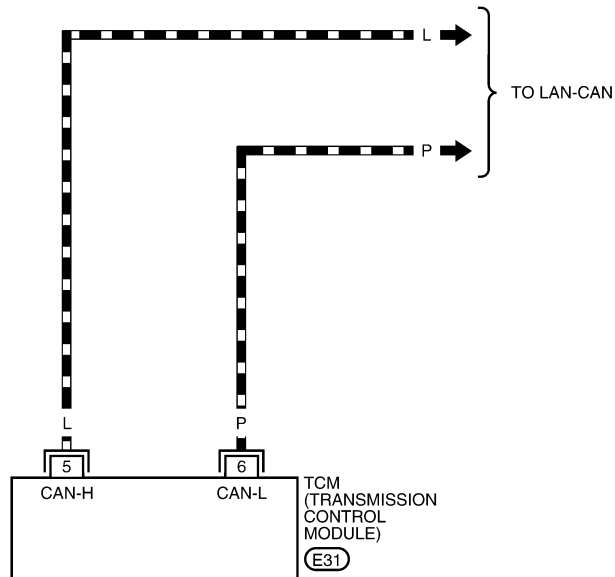

BCWA0648E

TCM TERMINALS AND REFERENCE VALUES
Refer to [AT-75. "TCM Terminal and Reference Value"](#).

U1000 CAN COMM CIRCUIT

< SERVICE INFORMATION >

Diagnosis Procedure

INFOID:000000005928112

1. CHECK CAN COMMUNICATION CIRCUIT

With CONSULT-III

1. Turn ignition switch ON and start engine.
2. Select "SELF-DIAG RESULTS" mode for "TRANSMISSION" with CONSULT-III.

Is any malfunction of the "U1000 CAN COMM CIRCUIT" indicated?

- YES >> Print out CONSULT-III screen, Go to LAN section. Refer to [LAN-26. "CAN System Specification Chart"](#).
- NO >> **INSPECTION END**

A
B
AT
D
E
F
G
H
I
J
K
L
M
N
O
P

P0705 TRANSMISSION RANGE SWITCH A

< SERVICE INFORMATION >

P0705 TRANSMISSION RANGE SWITCH A

Description

INFOID:000000005928113

- The transmission range switch detects the selector lever position and sends a signal to the TCM.

CONSULT-III Reference Value in Data Monitor Mode

INFOID:000000005928114

Item name	Condition	Display value
PN POSI SW	When setting selector lever to "N" or "P" position.	ON
	When setting selector lever to other positions.	OFF
R POSITION SW	When setting selector lever to "R" position.	ON
	When setting selector lever to other positions.	OFF
D POSITION SW	When setting selector lever to "D" position.	ON
	When setting selector lever to other positions.	OFF
2 POSITION SW	When setting selector lever to "2" position.	ON
	When setting selector lever to other positions.	OFF
1 POSITION SW	When setting selector lever to "1" position.	ON
	When setting selector lever to other positions.	OFF

On Board Diagnosis Logic

INFOID:000000005928115

- This is an OBD-II self-diagnostic item.
- Diagnostic trouble code "P0705 T/M RANGE SWITCH A" with CONSULT-III is detected when TCM does not receive the correct voltage signal from the switch based on the gear position.

Possible Cause

INFOID:000000005928116

- Harness or connectors
[The transmission range switch circuit is open or shorted.]
- Transmission range switch

DTC Confirmation Procedure

INFOID:000000005928117

CAUTION:

- **Always drive vehicle at a safe speed.**
- **If performing this "DTC Confirmation Procedure" again, always turn ignition switch OFF and wait at least 10 seconds before continuing.**

After the repair, perform the following procedure to confirm the malfunction is eliminated.

WITH CONSULT-III

1. Turn ignition switch ON. (Do not start engine.)
2. Select "DATA MONITOR" mode for "TRANSMISSION" with CONSULT-III.
3. Touch "START".
4. Start engine and maintain the following conditions for at least 5 consecutive seconds.
VEHICLE SPEED: 10 km/h (6 MPH) or more
THROTTLE POSI: More than 1.0/8
SLCT LVR POSI: "D" position
5. If the check result is NG, go to [AT-92, "Diagnosis Procedure"](#).

WITH GST

Follow the procedure "WITH CONSULT-III".

P0705 TRANSMISSION RANGE SWITCH A

< SERVICE INFORMATION >

Wiring Diagram - AT - TR/SW

INFOID:000000005928118

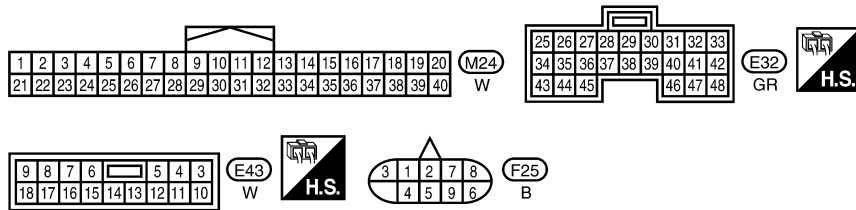
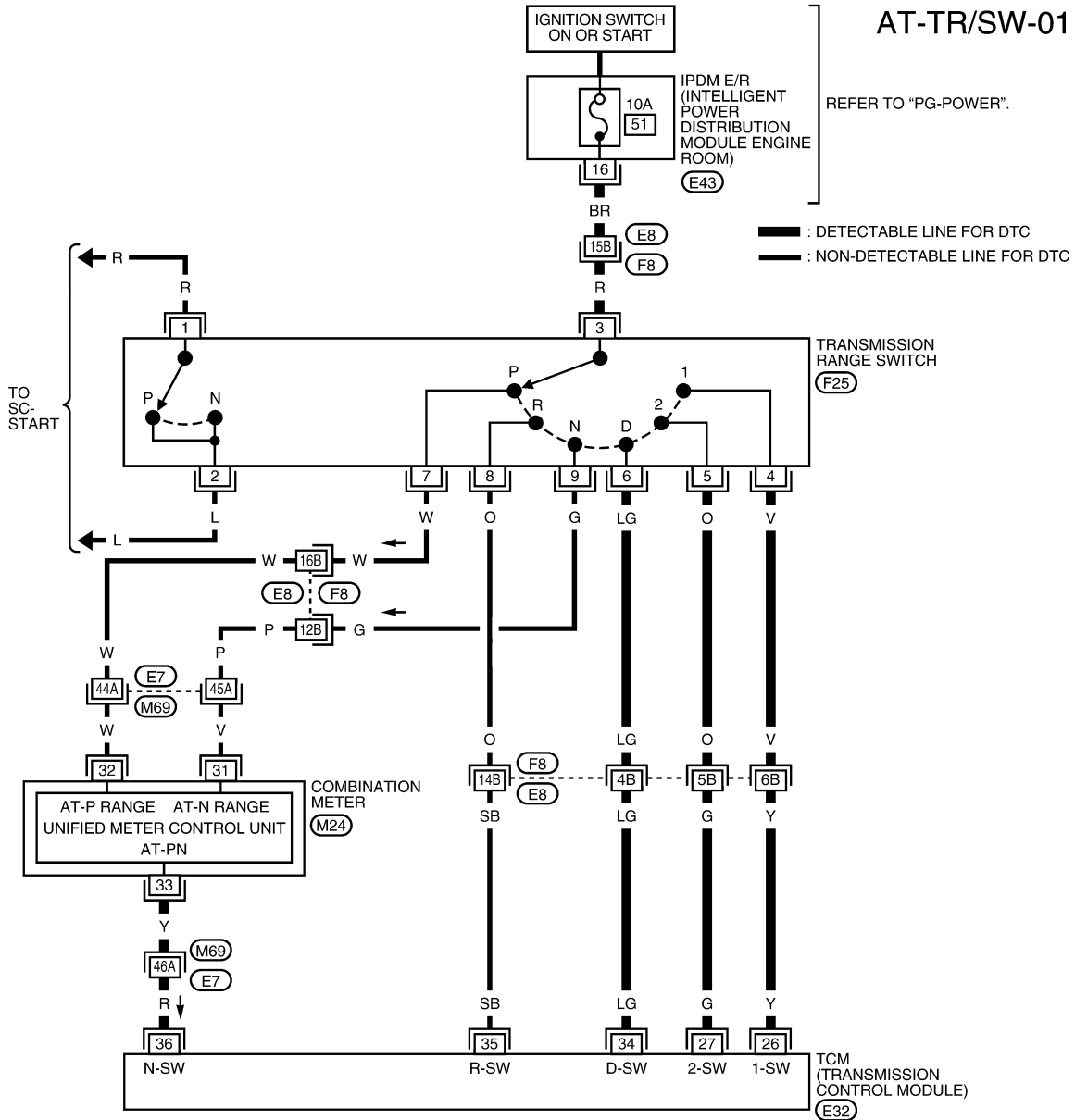

REFER TO THE FOLLOWING.
 (M69), (F8) - SUPER
 MULTIPLE JUNCTION (SMJ)

ABDWA0211GB

TCM TERMINALS AND REFERENCE VALUES

Refer to [AT-75, "TCM Terminal and Reference Value"](#).

P0705 TRANSMISSION RANGE SWITCH A

< SERVICE INFORMATION >

Diagnosis Procedure

INFOID:000000005928119

1. CHECK INPUT SIGNAL

With CONSULT-III

1. Turn ignition switch ON. (Do not start engine.)
2. Select "TCM INPUT SIGNALS" in "DATA MONITOR" mode for "TRANSMISSION" with CONSULT-III.
3. Read out "P·N", "R", "D", "2" and "1" position switches moving selector lever to each position.

Item name	Condition	Display value
PN POSI SW	When setting selector lever to "N" or "P" position.	ON
	When setting selector lever to other positions.	OFF
R POSITION SW	When setting selector lever to "R" position.	ON
	When setting selector lever to other positions.	OFF
D POSITION SW	When setting selector lever to "D" positions.	ON
	When setting selector lever to other positions.	OFF
2 POSITION SW	When setting selector lever to "2" position.	ON
	When setting selector lever to other positions.	OFF
1 POSITION SW	When setting selector lever to "1" position.	ON
	When setting selector lever to other positions.	OFF

OK or NG

- OK >> GO TO 6.
 NG >> GO TO 3.

2. CHECK INPUT SIGNAL

Without CONSULT-III

1. Turn ignition switch ON. (Do not start engine.)
2. Check voltage between TCM connector terminals and ground while moving selector lever through each position.

Selector lever position	Terminal				
	36	35	34	27	26
P, N	B	0	0	0	0
R	0	B	0	0	0
D	0	0	B	0	0
2	0	0	0	B	0
1	0	0	0	0	B

B: Battery voltage
0: 0V

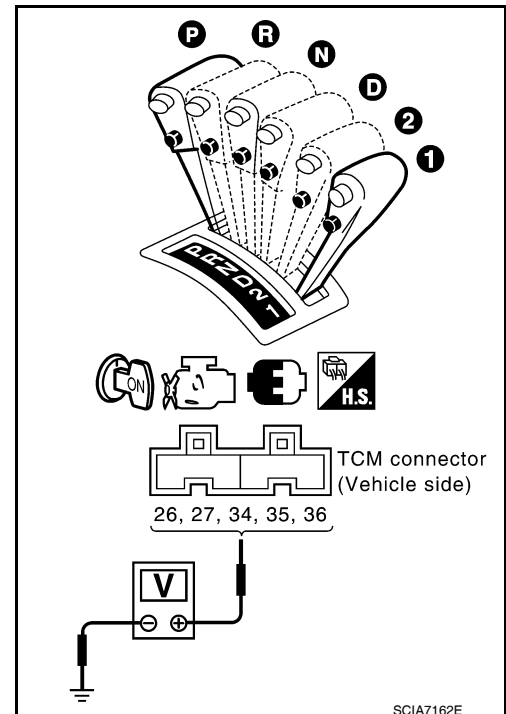

OK or NG

- OK >> GO TO 6.

P0705 TRANSMISSION RANGE SWITCH A

< SERVICE INFORMATION >

NG >> GO TO 3.

3. CHECK TRANSMISSION RANGE SWITCH

1. Turn ignition switch OFF.
2. Disconnect transmission range switch harness connector.
3. Check continuity between transmission range switch harness connector terminals.

Selector lever position	Connector	Terminal	Continuity
P	F25	1 - 2, 3 - 7	Yes
R		3 - 8	*Continuity should not exist in positions other than the specified positions.
N		1 - 2, 3 - 9	
D		3 - 6	
2		3 - 5	
1		3 - 4	

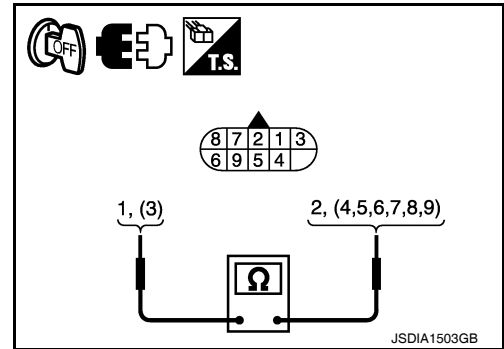

OK or NG

OK >> GO TO 5.

NG >> GO TO 4.

4. CHECK CONTROL CABLE ADJUSTMENT

Check transmission range switch again with control cable disconnected from manual shaft of A/T assembly. Refer to test group 3.

OK or NG

OK >> Adjust control cable. Refer to [AT-217. "Adjustment of A/T Position"](#) .

- NG >> Check transmission range switch (Refer to test group 1) again after adjusting transmission range switch (Refer to [AT-225](#)).
- If OK, **INSPECTION END**
 - If NG, repair or replace transmission range switch. Refer to [AT-225. "Transmission Range Switch"](#) .

5. DETECT MALFUNCTIONING ITEM

Check the following items:

- Harness for short or open between ignition switch and transmission range switch.
- Harness for short or open between transmission range switch and TCM.
- Harness for short or open between combination meter and transmission range switch.
- Harness for short or open between combination meter and TCM.
- 10A fuse (No.51, located in the IPDM E/R)
- Combination meter. Refer to [DI-4](#) .
- Ignition switch. Refer to [PG-4](#) .

OK or NG

OK >> GO TO 6.

NG >> Repair or replace damaged parts.

6. CHECK DTC

Perform [AT-90. "DTC Confirmation Procedure"](#) .

OK or NG

OK >> **INSPECTION END**

NG >> GO TO 7.

7. CHECK TCM

1. Check TCM input/output signal. Refer to [AT-75. "TCM Terminal and Reference Value"](#) .
2. If NG, recheck TCM pin terminals for damage or loose connection with harness connector.

OK or NG

OK >> **INSPECTION END**

NG >> Repair or replace damaged parts.

P0705 TRANSMISSION RANGE SWITCH A

< SERVICE INFORMATION >

Component Inspection

INFOID:000000005928120

TRANSMISSION RANGE SWITCH

1. Check continuity between transmission range switch harness connector terminals.

Selector lever position	Connector	Terminal	Continuity
"P"	F25	1 - 2, 3 - 7	Yes *Continuity should not exist in positions other than the specified positions.
"R"		3 - 8	
"N"		1 - 2, 3 - 9	
"D"		3 - 6	
"2"		3 - 5	
"1"		3 - 4	

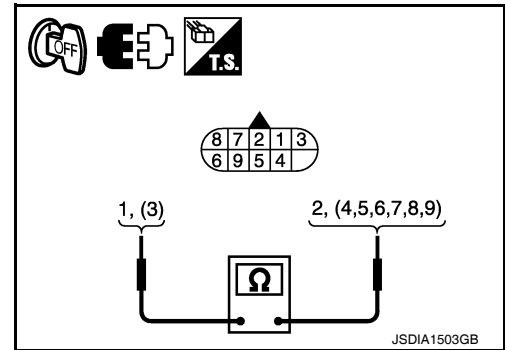

2. If NG, check again with control cable (2) disconnected from manual shaft of A/T assembly. Refer to step 1.
(1): Lock nut
(3): Manual shaft
3. If OK on step 2, adjust control cable (2). Refer to [AT-217. "Adjustment of A/T Position"](#) .
4. If NG on step 2, remove transmission range switch from A/T and check continuity of transmission range switch terminals. Refer to step 1.
5. If OK on step 4, adjust transmission range switch. Refer to [AT-225. "Transmission Range Switch"](#) .
6. If NG on step 4, replace transmission range switch. Refer to [AT-225. "Transmission Range Switch"](#) .

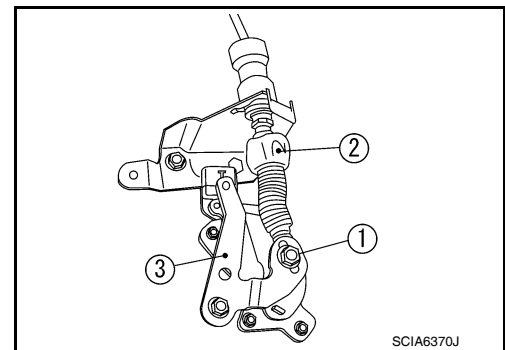

P0710 TRANSMISSION FLUID TEMPERATURE SENSOR A

< SERVICE INFORMATION >

P0710 TRANSMISSION FLUID TEMPERATURE SENSOR A

Description

INFOID:000000005928121

The A/T fluid temperature sensor detects the A/T fluid temperature and sends a signal to the TCM.

CONSULT-III Reference Value in Data Monitor Mode

INFOID:000000005928122

Remarks: Specification data are reference values.

Item name	Condition	Display value (Approx.)
FLUID TEMP SE	When A/T fluid temperature is 20°C (68°F).	1.5 V
	When A/T fluid temperature is 80°C (176°F).	0.5 V

On Board Diagnosis Logic

INFOID:000000005928123

- This is an OBD-II self-diagnostic item.
- Diagnostic trouble code “P0710 FLUID TEMP SENSOR A” with CONSULT-III is detected when TCM receives an excessively low or high voltage from the sensor.

Possible Cause

INFOID:000000005928124

- Harness or connector
(The sensor circuit is open or shorted.)
- A/T fluid temperature sensor

DTC Confirmation Procedure

INFOID:000000005928125

CAUTION:

- **Always drive vehicle at a safe speed.**
- **If performing this “DTC Confirmation Procedure” again, always turn ignition switch OFF and wait at least 10 seconds before continuing.**

After the repair, perform the following procedure to confirm the malfunction is eliminated.

WITH CONSULT-III

1. Turn ignition switch ON and select “DATA MONITOR” mode for “TRANSMISSION” with CONSULT-III.
2. Touch “START”.
3. Start engine and maintain the following conditions for at least 10 minutes (Total). (It is not necessary to maintain continuously.)
ENGINE SPEED: 450 rpm or more
VEHICLE SPEED: 10 km/h (6 MPH) or more
THROTTLE POS: More than 1.0/8
SLCT LVR POS: “D” position
4. If the check result is NG, go to [AT-96, "Diagnosis Procedure"](#).

WITH GST

Follow the procedure “With CONSULT-III”.

P0710 TRANSMISSION FLUID TEMPERATURE SENSOR A

< SERVICE INFORMATION >

Wiring Diagram - AT - FTS

INFOID:000000005928126

AT-FTS-01

— : DETECTABLE LINE FOR DTC
 - - - : NON-DETECTABLE LINE FOR DTC

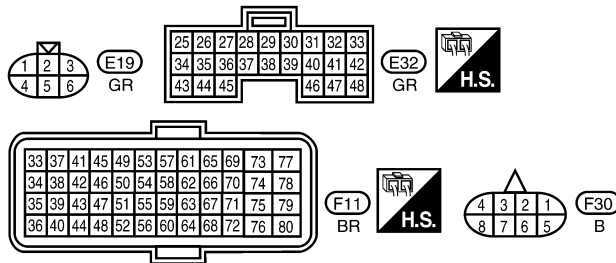
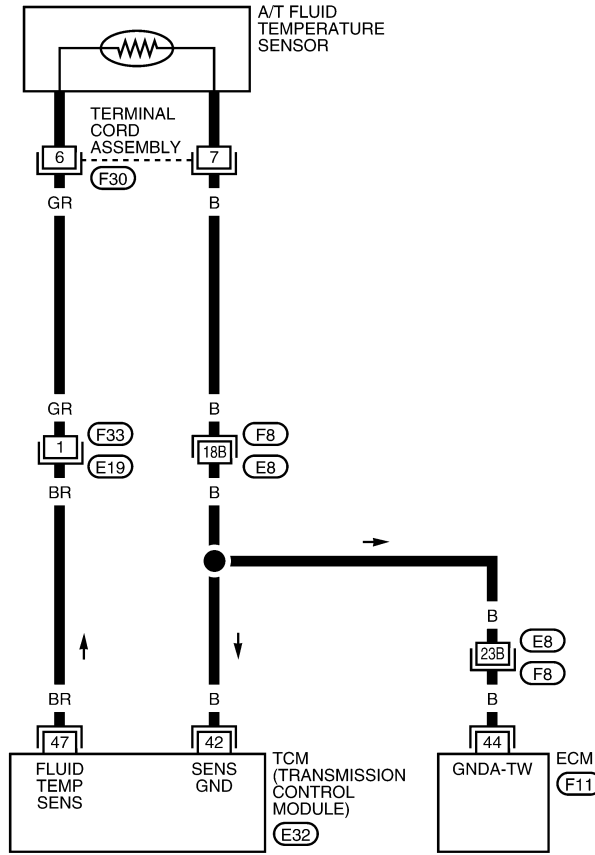

REFER TO THE FOLLOWING.
 (F8) - SUPER MULTIPLE JUNCTION (SMJ)

ABDWA0212GB

TCM TERMINALS AND REFERENCE VALUES

Refer to [AT-75. "TCM Terminal and Reference Value"](#).

Diagnosis Procedure

INFOID:000000005928127

1. CHECK INPUT SIGNAL

P0710 TRANSMISSION FLUID TEMPERATURE SENSOR A

< SERVICE INFORMATION >

④ With CONSULT-III

1. Start engine.
2. Select "TCM INPUT SIGNALS" in "DATA MONITOR" mode for "TRANSMISSION" with CONSULT-III.
3. Read out the value of "FLUID TEMP SE".

Item name	Condition	Display value (Approx.)
FLUID TEMP SE	When A/T fluid temperature is 20°C (68°F).	1.5 V
	When A/T fluid temperature is 80°C (176°F).	0.5 V

⊗ Without CONSULT-III

1. Start engine.
2. Check voltage TCM connector terminals while warming up A/T.

Item	Connector	Terminal	Condition	Judgment standard (Approx.)
A/T fluid temperature sensor	E32	47 - 42	When A/T fluid temperature is 20°C (68°F).	1.5 V
			When A/T fluid temperature is 80°C (176°F).	0.5 V

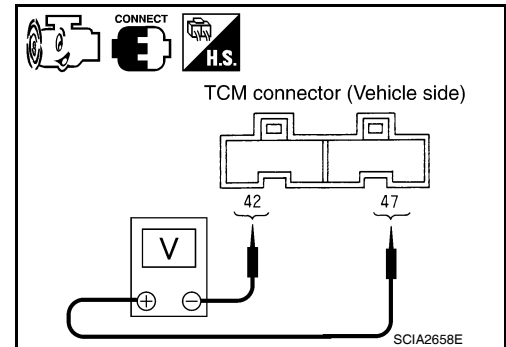

OK or NG

- OK >> GO TO 7.
- NG >> GO TO 2.

2. DETECT MALFUNCTIONING ITEMS

Check the following.

- Harness for short or open between TCM, ECM and terminal cord assembly
- Ground circuit for ECM, Refer to [EC-123](#) (HR16DE), [EC-633](#) (MR18DE).

OK or NG

- OK >> GO TO 3.
- NG >> Repair or replace damaged parts.

3. CHECK FLUID TEMPERATURE SENSOR CIRCUIT

1. Turn ignition switch OFF.
2. Disconnect the TCM connector.
3. Check resistance between TCM connector terminals.

Item	Connector	Terminal	Temperature [°C (°F)]	Resistance (Approx.)
A/T fluid temperature sensor	E32	47 - 42	20 (68)	2.5 kΩ
			80 (176)	0.3 kΩ

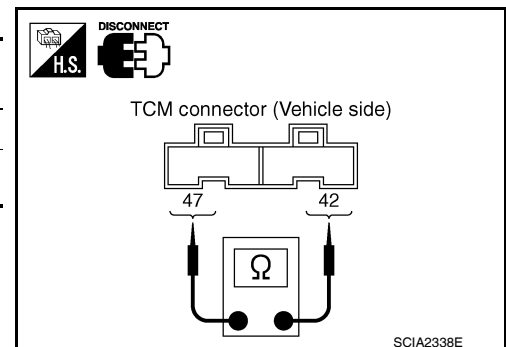

OK or NG

- OK >> GO TO 7.
- NG >> GO TO 4.

4. CHECK HARNESS BETWEEN TCM AND TERMINAL CORD ASSEMBLY HARNESS CONNECTOR

1. Turn ignition switch OFF.
2. Disconnect terminal cord assembly harness connector and TCM connector.

P0710 TRANSMISSION FLUID TEMPERATURE SENSOR A

< SERVICE INFORMATION >

3. Check continuity between terminal cord assembly harness connector terminal and TCM connector terminal.

Item	Connector	Terminal	Continuity
TCM	E32	42	Yes
Terminal cord assembly harness connector	F30	7	
TCM	E32	47	Yes
Terminal cord assembly harness connector	F30	6	

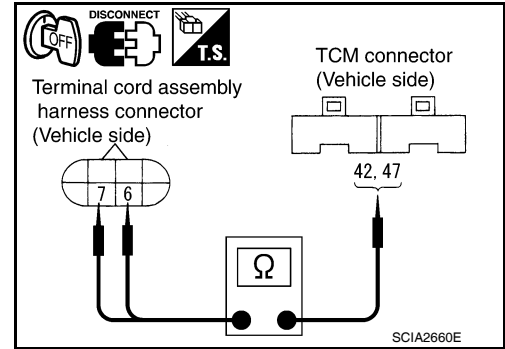

4. If OK, check harness for short to ground and short to power.
5. If OK, check continuity between ground and transaxle assembly.
6. Reinstall any part removed.

OK or NG

OK >> GO TO 5.

NG >> Repair open circuit or short to ground or short to power in harness or connectors.

5. CHECK A/T FLUID TEMPERATURE SENSOR WITH TERMINAL CORD ASSEMBLY

1. Turn ignition switch OFF.
2. Disconnect terminal cord assembly harness connector in engine room.
3. Check resistance between terminal cord assembly harness connector terminals.

Item	Connector	Terminal	Temperature [°C (°F)]	Resistance (Approx.)
A/T fluid temperature sensor	F30	6 - 7	20 (68)	2.5 kΩ
			80 (176)	0.3 kΩ

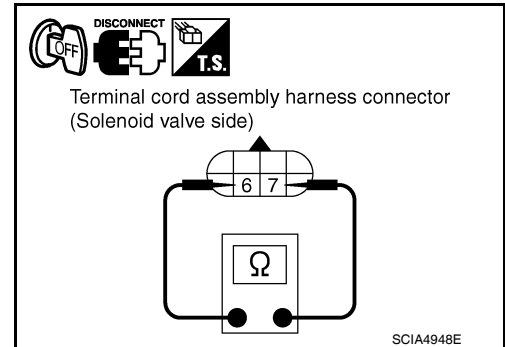

4. Reinstall any part removed.

OK or NG

OK >> GO TO 6.

NG >> Repair or replace damaged parts.

6. DETECT MALFUNCTIONING ITEM

1. Remove oil pan. Refer to [AT-222, "Control Valve Assembly and Accumulators"](#).
2. Check the following.
 - A/T fluid temperature sensor
 - Check resistance between terminal cord assembly harness connector terminals while changing temperature as shown.

Item	Connector	Terminal	Temperature [°C (°F)]	Resistance (Approx.)
A/T fluid temperature sensor	F30	6 - 7	20 (68)	2.5 kΩ
			80 (176)	0.3 kΩ

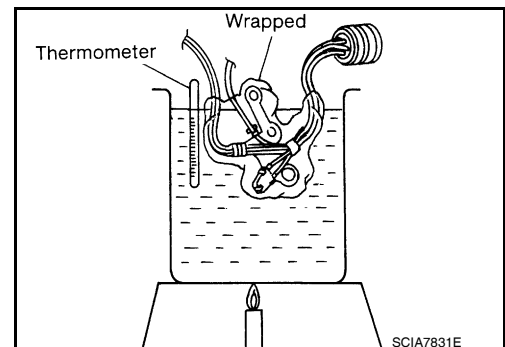

- Harness of terminal cord assembly for short or open

OK or NG

OK >> GO TO 7.

NG >> Repair or replace damaged parts.

7. CHECK DTC

Perform [AT-95, "DTC Confirmation Procedure"](#).

OK or NG

P0710 TRANSMISSION FLUID TEMPERATURE SENSOR A

< SERVICE INFORMATION >

- OK >> **INSPECTION END**
- NG >> GO TO 8.

8. CHECK TCM

1. Check TCM input/output signal. Refer to [AT-75, "TCM Terminal and Reference Value"](#).
2. If NG, recheck TCM pin terminals for damage or loose connection with harness connector.

OK or NG

- OK >> **INSPECTION END**
- NG >> Repair or replace damaged parts.

Component Inspection

INFOID:000000005928128

A/T FLUID TEMPERATURE SENSOR

- Remove oil pan. Refer to [AT-222, "Control Valve Assembly and Accumulators"](#).
- Check resistance between terminal cord assembly harness connector terminals while changing temperature as shown.

Item	Connector	Terminal	Temperature [°C (°F)]	Resistance (Approx.)
A/T fluid temperature sensor	F30	6 - 7	AT-380, "A/T Fluid Temperature Sensor"	

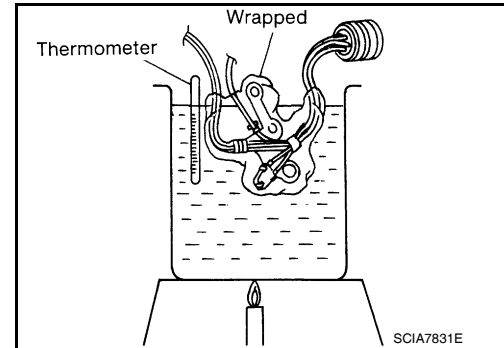

A
B
AT
D
E
F
G
H
I
J
K
L
M
N
O
P

P0720 OUTPUT SPEED SENSOR

< SERVICE INFORMATION >

P0720 OUTPUT SPEED SENSOR

Description

INFOID:000000005928129

The output speed sensor detects the revolution of the idler gear parking pawl lock gear and emits a pulse signal. The pulse signal is sent to the TCM which converts it into vehicle speed.

CONSULT-III Reference Value in Data Monitor Mode

INFOID:000000005928130

Remarks: Specification data are reference values.

Item name	Condition	Display value
VHCL/S SE-A/T	During driving	Approximately matches the speedometer reading.

On Board Diagnosis Logic

INFOID:000000005928131

- This is an OBD-II self-diagnostic item.
- Diagnostic trouble code "P0720 OUTPUT SPEED SENSOR" with CONSULT-III or 1st judgement flicker without CONSULT-III is detected when TCM does not receive the proper voltage signal from the sensor.

Possible Cause

INFOID:000000005928132

- Harness or connector
(The sensor circuit is open or shorted.)
- Output speed sensor

DTC Confirmation Procedure

INFOID:000000005928133

CAUTION:

- **Always drive vehicle at a safe speed.**
- **Be careful not to rev engine into the red zone on the tachometer.**
- **If performing this "DTC Confirmation Procedure" again, always turn ignition switch OFF and wait at least 10 seconds before continuing.**

After the repair, perform the following procedure to confirm the malfunction is eliminated.

④ WITH CONSULT-III

1. Turn ignition switch ON and select "DATA MONITOR" mode for "TRANSMISSION" with CONSULT-III.
2. Touch "START".
3. Drive vehicle and check for an increase of "VHCL/S SE-MTR" value.
If the check result is NG, go to [AT-102. "Diagnosis Procedure"](#).
If the check result is OK, go to following step.
4. Select "DATA MONITOR" mode for "TRANSMISSION" with CONSULT-III.
5. Touch "START".
6. Start engine and maintain the following conditions for at least 5 consecutive seconds.
VEHICLE SPEED: 30 km/h (19 MPH) or more
THROTTLE POSI: More than 1.0/8
SLCT LVR POSI: "D" position
Driving location: Driving the vehicle uphill (increased engine load) will help maintain the driving conditions required for this test.
If the check result is NG, go to [AT-102. "Diagnosis Procedure"](#).
If the check result is OK, go to following step.
7. Maintain the following conditions for at least 5 consecutive seconds.
ENGINE SPEED: 3,500 rpm or more
THROTTLE POSI: More than 1.0/8
SLCT LVR POSI: "D" position
Driving location: Driving the vehicle uphill (increased engine load) will help maintain the driving conditions required for this test.

④ WITH GST

Follow the procedure "WITH CONSULT-III".

⊗ WITHOUT CONSULT-III

1. Start engine.

P0720 OUTPUT SPEED SENSOR

< SERVICE INFORMATION >

2. Drive vehicle under the following conditions for more than 5 seconds.
Selector lever position: "D" position
Vehicle speed: 30 km/h (19 MPH) or more
Throttle position: greater than 1.0/8 of the full throttle position
3. Perform self-diagnosis. Refer to [AT-82. "Diagnosis Procedure without CONSULT-III"](#).
4. If the check result is NG, go to [AT-102. "Diagnosis Procedure"](#).

Wiring Diagram - AT - VSSA/T

INFOID:000000005928134

AT

AT-VSSA/T-01

: DETECTABLE LINE FOR DTC
 : NON-DETECTABLE LINE FOR DTC

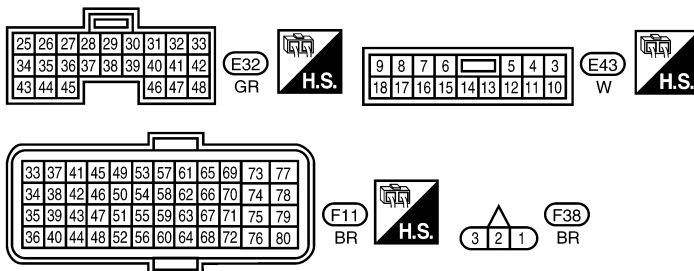
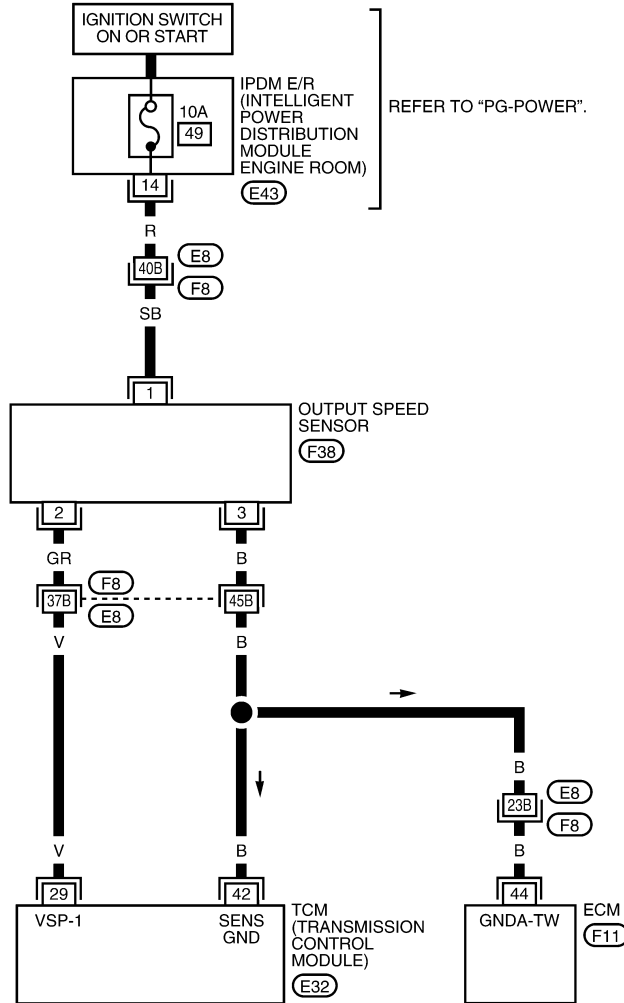

REFER TO THE FOLLOWING.
 (F8) - SUPER MULTIPLE JUNCTION (SMJ)

P0720 OUTPUT SPEED SENSOR

< SERVICE INFORMATION >

TCM TERMINALS AND REFERENCE VALUES

Refer to [AT-75, "TCM Terminal and Reference Value"](#).

Diagnosis Procedure

INFOID:000000005928135

1. CHECK INPUT SIGNAL

With CONSULT-III

1. Start engine.
2. Select "TCM INPUT SIGNALS" in "DATA MONITOR" mode for "TRANSMISSION" with CONSULT-III.
3. Read out the value of "VHCL/S SE-A/T" while driving.
Check the value changes according to driving speed.

OK or NG

- OK >> GO TO 8.
NG >> GO TO 2.

2. CHECK OUTPUT SPEED SENSOR

With CONSULT-III

1. Start engine.
2. Check power supply to output speed sensor by voltage between TCM connector terminals. Refer to [AT-168, "Wiring Diagram - AT - MAIN"](#) and [AT-101, "Wiring Diagram - AT - VSSA/T"](#).

Item	Connector	Terminal	Judgement standard (Approx.)
TCM	E31, E32	10 - 42	Battery voltage
		19 - 42	

3. If OK, check the pulse when vehicle cruises.

Item	Condition
Output speed sensor	When driving at 20 km/h (12 MPH), use the CONSULT-III pulse frequency measuring function.*1 CAUTION: Connect the diagnosis data link cable to the data link connector. *1: A circuit tester cannot be used to test this item.

Item	Connector	Terminal	Condition	Judgement standard (Approx.)
TCM	E32	29	When driving at 20 km/h (12 MPH)	150 Hz

OK or NG

- OK >> GO TO 8.
NG >> GO TO 3.

3. CHECK POWER AND SENSOR GROUND

1. Turn ignition switch OFF.
2. Disconnect the output speed sensor harness connector.
3. Turn ignition switch ON. (Do not start engine.)

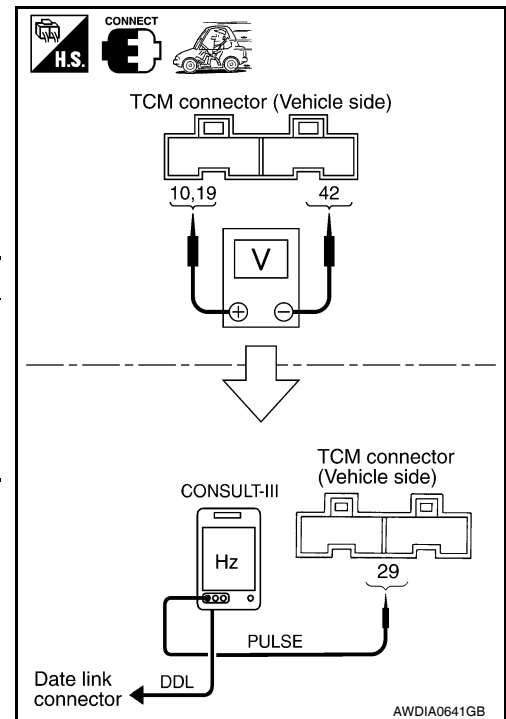

P0720 OUTPUT SPEED SENSOR

< SERVICE INFORMATION >

4. Check voltage between output speed sensor harness connector terminals.

Item	Connector	Terminal	Judgement standard (Approx.)
Output speed sensor	F38	1 - 3	Battery voltage

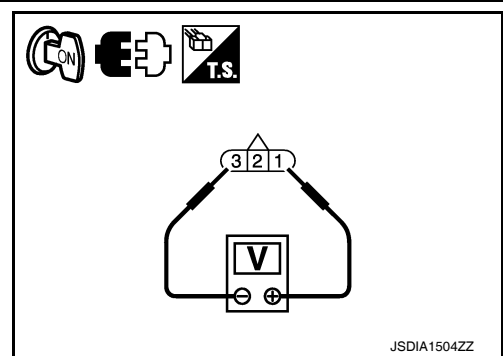

5. Check voltage between output speed sensor harness connector terminal and ground.

Item	Connector	Terminal	Judgement standard (Approx.)
Output speed sensor	F38	1 - ground	Battery voltage

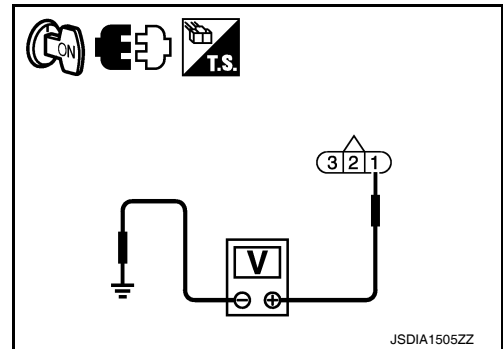

6. If OK, check harness for short to ground and short to power.
7. Reinstall any part removed.

OK or NG

OK >> GO TO 4.

NG - 1 >> Battery voltage is not supplied between terminals 1 and 3, terminals 1 and ground: GO TO 6.

NG - 2 >> Battery voltage is not supplied between terminals 1 and 3 only: GO TO 7.

4. CHECK HARNESS BETWEEN TCM AND OUTPUT SPEED SENSOR

1. Turn ignition switch OFF.
2. Disconnect the TCM connector and output speed sensor harness connector.
3. Check continuity between TCM connector (A) terminal and output speed sensor harness connector (B) terminal.

Item	Connector	Terminal	Continuity
TCM	E32	29	Yes
Output speed sensor	F38	2	

4. If OK, check harness for short to ground and short to power.
5. Reinstall any part removed.

OK or NG

OK >> GO TO 5.

NG >> Repair open circuit or short to ground or short to power in harness or connectors.

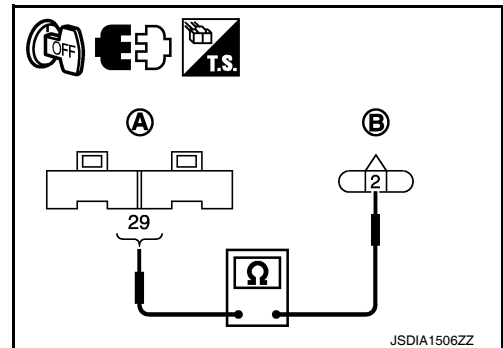

5. CHECK TCM

1. Check TCM input/output signal. Refer to [AT-75. "TCM Terminal and Reference Value"](#).
2. If NG, re-check TCM pin terminals for damage or loose connection with harness connector.

OK or NG

OK >> GO TO 8.

NG >> Repair or replace damaged parts.

6. CHECK HARNESS BETWEEN TCM AND OUTPUT SPEED SENSOR (POWER)

1. Turn ignition switch OFF.
2. Disconnect the TCM connector and output speed sensor harness connector.

P0720 OUTPUT SPEED SENSOR

< SERVICE INFORMATION >

3. Check continuity between TCM connector (A) terminals and output speed sensor harness connector (B) terminal. Refer to [AT-50. "Circuit Diagram"](#) and [AT-168. "Wiring Diagram - AT - MAIN"](#)

Item	Connector	Terminal	Continuity
TCM	E31	10	Yes
Output speed sensor	F38	1	
TCM	E31	19	Yes
Output speed sensor	F38	1	

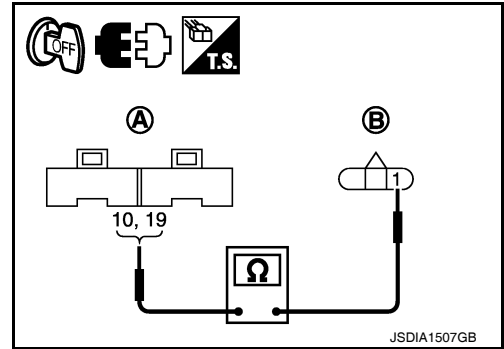

4. If OK, check harness for short to ground and short to power.
5. Reinstall any part removed.

OK or NG

- OK >> 10A fuse (No.49, located in the IPDM E/R) or ignition switch are malfunctioning.
 NG >> Repair open circuit or short to ground or short to power in harness or connectors.

7. CHECK HARNESS BETWEEN TCM AND OUTPUT SPEED SENSOR (SENSOR GROUND)

1. Turn ignition switch OFF.
2. Disconnect the TCM connector and output speed sensor harness connector.
3. Check continuity between TCM connector (A) terminal and output speed sensor harness connector (B) terminal.

Item	Connector	Terminal	Continuity
TCM	E32	42	Yes
Output speed sensor	F38	3	

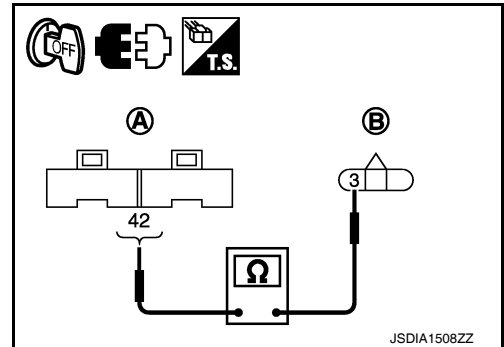

4. If OK, check harness for short to ground and short to power.
5. Reinstall any part removed.

OK or NG

- OK >> GO TO 5.
 NG >> Repair open circuit or short to ground or short to power in harness or connectors.

8. CHECK DTC

Perform [AT-100. "DTC Confirmation Procedure"](#) .

OK or NG

- OK >> **INSPECTION END**
 NG >> GO TO 5.

P0725 ENGINE SPEED

< SERVICE INFORMATION >

P0725 ENGINE SPEED

Description

INFOID:000000005928136

The engine speed signal is sent from the ECM to the TCM.

CONSULT-III Reference Value in Data Monitor Mode

INFOID:000000005928137

Remarks: Specification data are reference values.

Item name	Condition	Display value
ENGINE SPEED	Engine running	Approximately matches the tachometer reading.

On Board Diagnosis Logic

INFOID:000000005928138

- This is an OBD-II self-diagnostic item.
- Diagnostic trouble code “P0725 ENGINE SPEED” with CONSULT-III or 9th judgement flicker without CONSULT-III is detected when TCM does not receive the proper voltage signal from ECM.

Possible Cause

INFOID:000000005928139

Harness or connector
(Circuit is open or shorted.)

DTC Confirmation Procedure

INFOID:000000005928140

CAUTION:

- **Always drive vehicle at a safe speed.**
- **If performing this “DTC Confirmation Procedure” again, always turn ignition switch OFF and wait at least 10 seconds before continuing.**

After the repair, perform the following procedure to confirm the malfunction is eliminated.

WITH CONSULT-III

1. Turn ignition switch ON and select “DATA MONITOR” mode for “TRANSMISSION” with CONSULT-III.
2. Touch “START”.
3. Start engine and maintain the following conditions for at least 10 consecutive seconds.
VEHICLE SPEED: 10 km/h (6 MPH) or more
THROTTLE POSI: More than 1.0/8
SLCT LVR POSI: “D” position
4. If the check result is NG, go to [AT-107. "Diagnosis Procedure"](#) .

WITH GST

Follow the procedure “WITH CONSULT-III”.

WITHOUT CONSULT-III

1. Start engine.
2. Drive vehicle under the following conditions for more than 10 seconds.
Selector lever position: “D” position
Vehicle speed: Higher than 10 km/h (6 MPH)
Throttle position: Greater than 1.0/8 of the full throttle position
3. Perform self-diagnosis. Refer to [AT-82. "Diagnosis Procedure without CONSULT-III"](#) .
4. If the check result is NG, go to [AT-107. "Diagnosis Procedure"](#) .

P0725 ENGINE SPEED

< SERVICE INFORMATION >

Wiring Diagram - AT - ENGSS

INFOID:000000005928141

AT-ENGSS-01

: DETECTABLE LINE FOR DTC
 : NON-DETECTABLE LINE FOR DTC

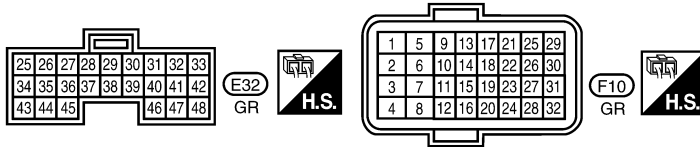
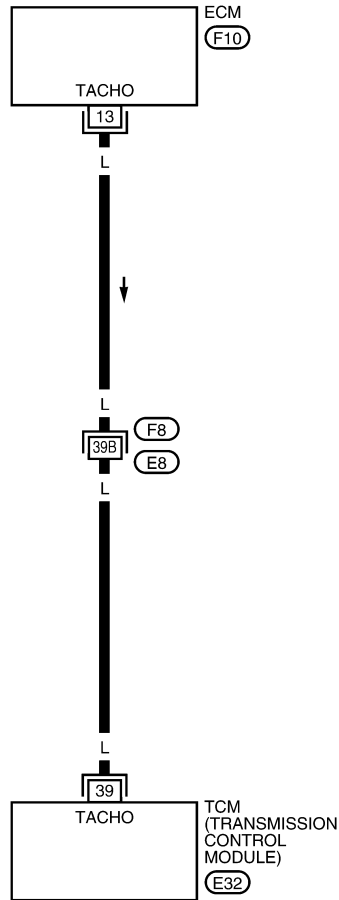

REFER TO THE FOLLOWING.

(F8) - SUPER MULTIPLE JUNCTION (SMJ)

BCWA0652E

TCM TERMINALS AND REFERENCE VALUES

Refer to [AT-75. "TCM Terminal and Reference Value"](#).

P0725 ENGINE SPEED

< SERVICE INFORMATION >

Diagnosis Procedure

INFOID:000000005928142

1. CHECK DTC WITH ECM

Check DTC with CONSULT-III "ENGINE".

Turn ignition switch ON and select "SELF-DIAGNOSTIC RESULTS" mode for "ENGINE" with CONSULT-III. Refer to [EC-106. "CONSULT-III Function"](#) (HR16DE), [EC-612. "CONSULT-III Function \(ENGINE\)"](#) (MR18DE).

OK or NG

OK >> GO TO 2.

NG >> Check ignition signal circuit for engine control. Refer to [EC-442. "Description"](#) (HR16DE), [EC-1019. "Component Description"](#) (MR18DE).

2. CHECK INPUT SIGNAL



With CONSULT-III

1. Start engine.
2. Select "TCM INPUT SIGNALS" in "DATA MONITOR" mode for "TRANSMISSION" with CONSULT-III.
3. Read out the value of "ENGINE SPEED". Check engine speed changes according to throttle position.

Item name	Condition	Display value
ENGINE SPEED	Engine running	Approximately matches the tachometer reading.

Without CONSULT-III

1. Start engine.
2. Check voltage between TCM harness connector terminal and ground.

item	Connector	Terminal	Condition	Judgement standard (Approx.)
Engine speed signal	E32	39 - Ground	 and 	Refer to EC-464 (HR16DE), EC-605 (MR18DE).

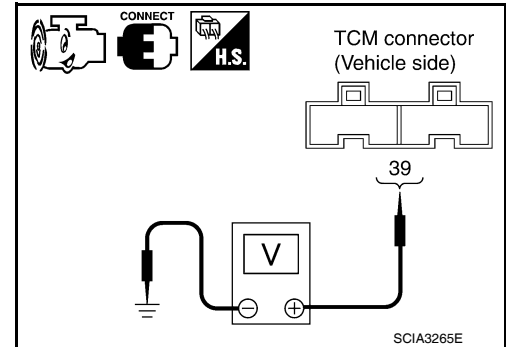

OK or NG

OK >> GO TO 4.

NG >> GO TO 3.

3. CHECK HARNESS BETWEEN TCM AND ECM

1. Turn ignition switch OFF.
2. Disconnect ECM connector and TCM connector.
3. Check continuity between ECM connector and TCM connector.

Item	Connector	Terminal	Continuity
TCM	E32	39	Yes
ECM	F10	13	

4. If OK, check harness for short to ground and short to power.
5. If OK, check continuity between body ground and transaxle assembly.
6. Reinstall any part removed.

OK or NG

OK >> GO TO 4.

NG >> Repair open circuit or short to ground or short to power in harness or connectors.

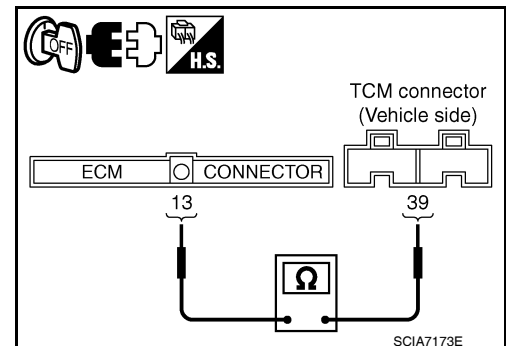

P0725 ENGINE SPEED

< SERVICE INFORMATION >

4.CHECK DTC

Perform [AT-105. "DTC Confirmation Procedure"](#).

OK or NG

OK >> **INSPECTION END**

NG >> GO TO 5.

5.CHECK TCM

1. Check TCM input/output signal. Refer to [AT-75. "TCM Terminal and Reference Value"](#).

2. If NG, recheck TCM pin terminals for damage or loose connection with harness connector.

OK or NG

OK >> **INSPECTION END**

NG >> Repair or replace damaged parts.

P0731 1GR INCORRECT RATIO

< SERVICE INFORMATION >

P0731 1GR INCORRECT RATIO

Description

INFOID:000000005928143

- This malfunction will not be detected while the OD OFF indicator lamp is indicating another self-diagnosis malfunction.
- This malfunction is detected when the A/T does not shift into first gear position as instructed by the TCM. This is not caused by electrical malfunction (circuits open or shorted) but by mechanical malfunction such as control valve sticking, improper solenoid valve operation, etc.

Gear position	1	2	3	4
Shift solenoid valve A	ON (Closed)	OFF (Open)	OFF (Open)	ON (Closed)
Shift solenoid valve B	ON (Closed)	ON (Closed)	OFF (Open)	OFF (Open)

On Board Diagnosis Logic

INFOID:000000005928144

- This is an OBD-II self-diagnostic item.
- Diagnostic trouble code “P0731 1GR INCORRECT RATIO” with CONSULT-III is detected when A/T cannot be shifted to the 1GR position even if electrical circuit is good.
- This diagnosis monitors actual gear position by checking the torque converter slip ratio calculated by TCM as follows:
Torque converter slip ratio = $A \times C/B$
A: Output shaft revolution signal from output speed sensor
B: Engine speed signal from ECM
C: Gear ratio determined as gear position which TCM supposes
If the actual gear position is higher than the position (1st) supposed by TCM, the slip ratio will be more than normal. In case the ratio exceeds the specified value, TCM judges this diagnosis malfunction.
This malfunction will be caused when either shift solenoid valve A is stuck open or shift solenoid valve B is stuck open.
- Gear positions supposed by TCM are as follows:
In case of gear position with no malfunctions: 1, 2, 3 and 4 positions
In case of gear position with shift solenoid valve A stuck open: 2*, 2, 3 and 3 positions
In case of gear position with shift solenoid valve B stuck open: 4*, 3, 3 and 4 positions to each gear position above
*: “P0731 1GR INCORRECT RATIO” is detected.

Possible Cause

INFOID:000000005928145

- Shift solenoid valve A
- Shift solenoid valve B
- Each clutch
- Hydraulic control circuit

DTC Confirmation Procedure

INFOID:000000005928146

CAUTION:

- **Always drive vehicle at a safe speed.**
- **If performing this “DTC Confirmation Procedure” again, always turn ignition switch OFF and wait at least 10 seconds before continuing.**

After the repair, perform the following procedure to confirm the malfunction is eliminated.

Ⓟ WITH CONSULT-III

1. Start engine and select “DATA MONITOR” mode for “TRANSMISSION” with CONSULT-III.
2. Touch “START”.
3. Make sure that output voltage of A/T fluid temperature sensor is within the range below.
FLUID TEMP SE: 0.4 - 1.5 V
If out of range, drive the vehicle to decrease the voltage (warm up the fluid) or stop engine to increase the voltage (cool down the fluid).
4. Select “1ST GR FNCTN P0731” of “DTC & SRT CONFIRMATION” mode for “TRANSMISSION” with CONSULT-III and touch “START”.

P0731 1GR INCORRECT RATIO

< SERVICE INFORMATION >

5. Accelerate vehicle to 20 to 25 km/h (12 to 16 MPH) under the following conditions and release the accelerator pedal completely.
THROTTLE POSI: Less than 1.0/8 (at all times during step 4)
SLCT LVR POSI: "D" position
 - **Make sure that "GEAR" shows "2" after releasing pedal.**
6. Depress accelerator pedal to WOT (more than 7.0/8 of "THROTTLE POSI") quickly from a speed of 20 to 25 km/h (12 to 16 MPH) until "TESTING" changes to "STOP VEHICLE" or "COMPLETED". (It will take approximately 3 seconds.)
 If the check result NG appears on CONSULT-III screen, go to [AT-110, "Diagnosis Procedure"](#).
 If "STOP VEHICLE" appears on CONSULT-III screen, go to the following step.
 - **Make sure that "GEAR" shows "1" when depressing accelerator pedal to WOT.**
 - **If "TESTING" does not appear on CONSULT-III for a long time, select "SELF-DIAG RESULTS" for "TRANSMISSION". In case a DTC other than "P0731 1GR INCORRECT RATIO" is shown, refer to [AT-77, "CONSULT-III Function \(TRANSMISSION\)"](#).**
7. Stop vehicle.
8. Follow the instruction displayed. (Check for normal shifting referring to the table below.)

Vehicle condition	Gear on actual transmission shift pattern when screen is changed to 1 → 2 → 3 → 4
No malfunction exists.	1 → 2 → 3 → 4
Malfunction for "1GR INCORRECT RATIO" exists.	2 → 2 → 3 → 3
	4 → 3 → 3 → 4

9. Make sure that "OK" is displayed. (If "NG" is displayed, refer to "Diagnostic Procedure".)
 Refer to [AT-110, "Diagnosis Procedure"](#).
 Refer to [AT-64, "Vehicle Speed at Which Gear Shifting Occurs"](#).

Ⓢ WITH GST

Follow the procedure "WITH CONSULT-III".

Diagnosis Procedure

INFOID:000000005928147

1. CHECK VALVE RESISTANCE

1. Remove control valve assembly. Refer to [AT-222, "Control Valve Assembly and Accumulators"](#).
 - Shift solenoid valve A
 - Shift solenoid valve B
2. Check resistance between terminal cord assembly harness connector terminals and ground. Refer to [AT-139, "Wiring Diagram - AT - SSV/A"](#) and [AT-144, "Wiring Diagram - AT - SSV/B"](#).

Solenoid valve	Connector	Terminal	Resistance (Approx.)
Shift solenoid valve A	F30	2 - Ground	20 - 30 Ω
Shift solenoid valve B		1 - Ground	5 - 20 Ω

OK or NG

- OK >> GO TO 2.
 NG >> Repair or replace damaged parts.

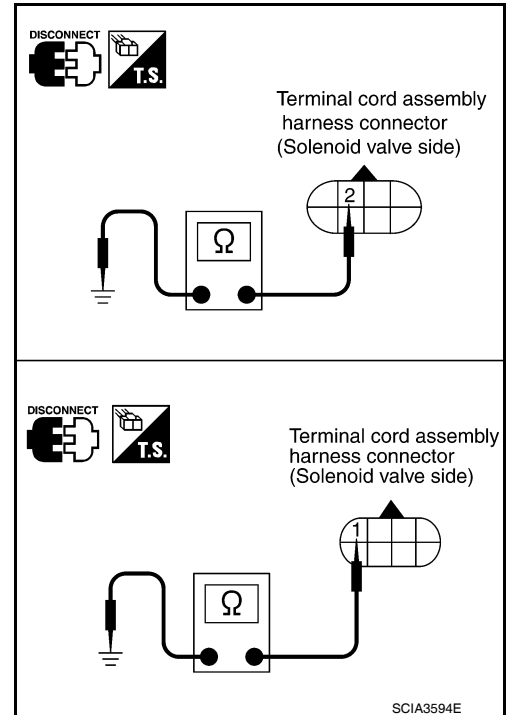

2. CHECK VALVE OPERATION

P0731 1GR INCORRECT RATIO

< SERVICE INFORMATION >

1. Remove control valve assembly. Refer to [AT-222. "Control Valve Assembly and Accumulators"](#).
 - Shift solenoid valve A
 - Shift solenoid valve B
2. Check solenoid valve by listening for its operating sound while applying battery voltage to the terminals and ground. Refer to [AT-139. "Wiring Diagram - AT - SSV/A"](#) and [AT-144. "Wiring Diagram - AT - SSV/B"](#).

OK or NG

- OK >> GO TO 3.
NG >> Repair or replace shift solenoid valve assembly.

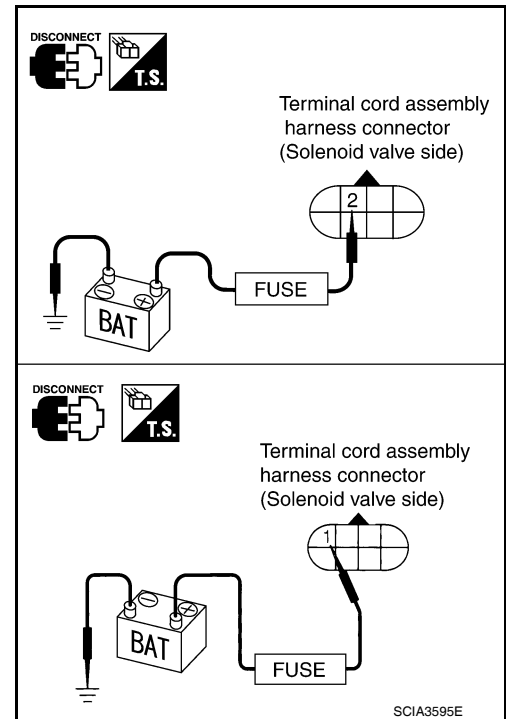

3. CHECK CONTROL VALVE

1. Disassemble control valve assembly. Refer to [AT-281. "Control Valve Assembly"](#).
2. Check to ensure that:
 - Valve, sleeve and plug slide along valve bore under their own weight.
 - Valve, sleeve and plug are free from burrs, dents and scratches.
 - Control valve springs are free from damage, deformation and fatigue.
 - Hydraulic line is free from obstacles.

OK or NG

- OK >> GO TO 4.
NG >> Repair control valve assembly.

4. CHECK DTC

Perform [AT-109. "DTC Confirmation Procedure"](#).

OK or NG

- OK >> **INSPECTION END**
NG >> Check control valve again. If NG, repair or replace control valve assembly.

P0732 2GR INCORRECT RATIO

< SERVICE INFORMATION >

P0732 2GR INCORRECT RATIO

Description

INFOID:000000005928148

- This malfunction will not be detected while the OD OFF indicator lamp is indicating another self-diagnosis malfunction.
- This malfunction is detected when the A/T does not shift into second gear position as instructed by the TCM. This is not caused by electrical malfunction (circuits open or shorted) but by mechanical malfunction such as control valve sticking, improper solenoid valve operation, etc.

Gear position	1	2	3	4
Shift solenoid valve A	ON (Closed)	OFF (Open)	OFF (Open)	ON (Closed)
Shift solenoid valve B	ON (Closed)	ON (Closed)	OFF (Open)	OFF (Open)

On Board Diagnosis Logic

INFOID:000000005928149

- This is an OBD-II self-diagnostic item.
- Diagnostic trouble code “P0732 2GR INCORRECT RATIO” with CONSULT-III is detected when A/T cannot be shifted to the 2GR position even if electrical circuit is good.
- This diagnosis monitors actual gear position by checking the torque converter slip ratio calculated by TCM as follows:
Torque converter slip ratio = A x C/B
A: Output shaft revolution signal from output speed sensor
B: Engine speed signal from ECM
C: Gear ratio determined as gear position which TCM supposes
If the actual gear position is higher than the position (2nd) supposed by TCM, the slip ratio will be more than normal. In case the ratio exceeds the specified value, TCM judges this diagnosis malfunction.
This malfunction will be caused when shift solenoid valve B is stuck open.
- Gear positions supposed by TCM are as follows:
In case of gear position with no malfunctions: 1, 2, 3 and 4 positions
In case of gear position with shift solenoid valve B stuck open: 4, 3*, 3 and 4 positions to each gear position above
*: “P0732 2GR INCORRECT RATIO” is detected.

Possible Cause

INFOID:000000005928150

- Shift solenoid valve B
- Each clutch
- Hydraulic control circuit

DTC Confirmation Procedure

INFOID:000000005928151

CAUTION:

- **Always drive vehicle at a safe speed.**
- **If performing this “DTC Confirmation Procedure” again, always turn ignition switch OFF and wait at least 10 seconds before continuing.**

After the repair, perform the following procedure to confirm the malfunction is eliminated.

Ⓟ WITH CONSULT-III

1. Start engine and select “DATA MONITOR” mode for “TRANSMISSION” with CONSULT-III.
2. Touch “START”.
3. Make sure that output voltage of A/T fluid temperature sensor is within the range below.
FLUID TEMP SE: 0.4 - 1.5 V
If out of range, drive the vehicle to decrease the voltage (warm up the fluid) or stop engine to increase the voltage (cool down the fluid).
4. Select “2ND GR FNCTN P0732” of “DTC & SRT CONFIRMATION” mode for “TRANSMISSION” with CONSULT-III and touch “START”.
5. Accelerate vehicle to 45 to 50 km/h (28 to 31 MPH) under the following conditions and release the accelerator pedal completely.
THROTTLE POSI: Less than 1.0/8
SLCT LVR POSI: “D” position

P0732 2GR INCORRECT RATIO

< SERVICE INFORMATION >

- **Make sure that "GEAR" shows "3" or "4" after releasing pedal.**
- 6. Depress accelerator pedal to WOT (more than 7.0/8 of "THROTTLE POSI") quickly from a speed of 45 to 50 km/h (28 to 31 MPH) until "TESTING" changes to "STOP VEHICLE" or "COMPLETE". (It will take approximately 3 seconds.)
If the check result NG appears on CONSULT-III screen, go to [AT-113, "Diagnosis Procedure"](#).
If "STOP VEHICLE" appears on CONSULT-III screen, go to following step.
- **Make sure that "GEAR" shows "2" when depressing accelerator pedal to WOT.**
- **If "TESTING" does not appear on CONSULT-III for a long time, select "SELF-DIAG RESULTS" for "TRANSMISSION". In case a DTC other than "P0732 2GR INCORRECT RATIO" is shown, refer to [AT-77, "CONSULT-III Function \(TRANSMISSION\)"](#).**
- 7. Stop vehicle.
- 8. Follow the instruction displayed. (Check for normal shifting referring to the table below.)

Vehicle condition	Gear on actual transmission shift pattern when screen is changed to 1 → 2 → 3 → 4
No malfunction exists	1 → 2 → 3 → 4
Malfunction for "2GR INCORRECT RATIO" exists.	4 → 3 → 3 → 4

- 9. Make sure that "OK" is displayed. (If "NG" is displayed, refer to "Diagnostic Procedure".)
Refer to [AT-113, "Diagnosis Procedure"](#).
Refer to [AT-64, "Vehicle Speed at Which Gear Shifting Occurs"](#).

WITH GST

Follow the procedure "WITH CONSULT-III".

Diagnosis Procedure

INFOID:000000005928152

1. CHECK VALVE RESISTANCE

- 1. Remove control valve assembly. Refer to [AT-222, "Control Valve Assembly and Accumulators"](#).
- Shift solenoid valve B
- 2. Check resistance between terminal cord assembly harness connector terminal and ground. Refer to [AT-144, "Wiring Diagram - AT - SSV/B"](#).

Solenoid valve	Connector	Terminal	Resistance (Approx.)
Shift solenoid valve B	F30	1 - Ground	5 - 20 Ω

OK or NG

- OK >> GO TO 2.
- NG >> Repair or replace shift solenoid valve assembly.

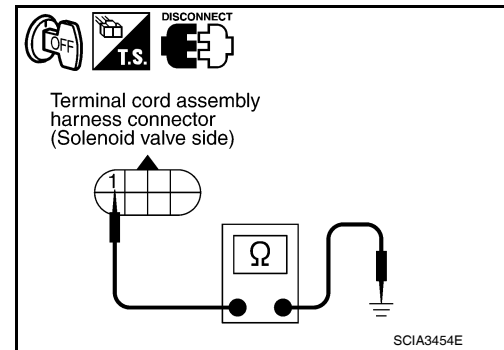

2. CHECK VALVE OPERATION

- 1. Remove control valve assembly. Refer to [AT-222, "Control Valve Assembly and Accumulators"](#).
- Shift solenoid valve B
- 2. Check solenoid valve by listening for its operating sound while applying battery voltage to the terminal and ground. Refer to [AT-144, "Wiring Diagram - AT - SSV/B"](#).

OK or NG

- OK >> GO TO 3.
- NG >> Repair or replace shift solenoid valve assembly.

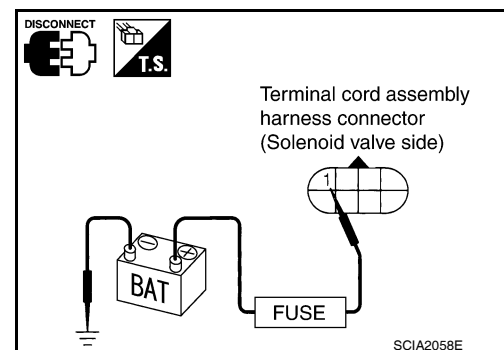

3. CHECK CONTROL VALVE

- 1. Disassemble control valve assembly. Refer to [AT-281, "Control Valve Assembly"](#).
- 2. Check to ensure that:

P0732 2GR INCORRECT RATIO

< SERVICE INFORMATION >

- Valve, sleeve and plug slide along valve bore under their own weight.
- Valve, sleeve and plug are free from burrs, dents and scratches.
- Control valve springs are free from damage, deformation and fatigue.
- Hydraulic line is free from obstacles.

OK or NG

- OK >> GO TO 4.
- NG >> Repair control valve assembly.

4. CHECK DTC

Perform [AT-112, "DTC Confirmation Procedure"](#).

OK or NG

- OK >> **INSPECTION END**
- NG >> Check control valve again. If NG, repair or replace control valve assembly.

P0733 3GR INCORRECT RATIO

< SERVICE INFORMATION >

P0733 3GR INCORRECT RATIO

Description

INFOID:000000005928153

- This malfunction will not be detected while the OD OFF indicator lamp is indicating another self-diagnosis malfunction.
- This malfunction is detected when the A/T does not shift into third gear position as instructed by the TCM. This is not caused by electrical malfunction (circuits open or shorted) but by mechanical malfunction such as control valve sticking, improper solenoid valve operation, malfunctioning servo piston or brake band, etc.

Gear position	1	2	3	4
Shift solenoid valve A	ON (Closed)	OFF (Open)	OFF (Open)	ON (Closed)
Shift solenoid valve B	ON (Closed)	ON (Closed)	OFF (Open)	OFF (Open)

On Board Diagnosis Logic

INFOID:000000005928154

- This is an OBD-II self-diagnostic item.
- Diagnostic trouble code “P0733 3GR INCORRECT RATIO” with CONSULT-III is detected when A/T cannot be shifted to the 3GR position even if electrical circuit is good.
- This diagnosis monitors actual gear position by checking the torque converter slip ratio calculated by TCM as follows:
Torque converter slip ratio = A x C/B
A: Output shaft revolution signal from output speed sensor
B: Engine speed signal from ECM
C: Gear ratio determined as gear position which TCM supposes
If the actual gear position is higher than the position (3rd) supposed by TCM, the slip ratio will be more than normal. In case the ratio exceeds the specified value, TCM judges this diagnosis malfunction.
This malfunction will be caused when shift solenoid valve A is stuck closed.
- Gear positions supposed by TCM are as follows.
In case of gear position with no malfunctions: 1, 2, 3 and 4 positions
In case of gear position with shift solenoid valve A stuck closed: 1, 1, 4* and 4 positions to each gear position above
*: “P0733 3GR INCORRECT RATIO” is detected.

Possible Cause

INFOID:000000005928155

- Shift solenoid valve A
- Each clutch
- Hydraulic control circuit

DTC Confirmation Procedure

INFOID:000000005928156

CAUTION:

- **Always drive vehicle at a safe speed.**
- **If performing this “DTC Confirmation Procedure” again, always turn ignition switch OFF and wait at least 10 seconds before continuing.**

After the repair, perform the following procedure to confirm the malfunction is eliminated.

Ⓟ WITH CONSULT-III

1. Start engine and select “DATA MONITOR” mode for “TRANSMISSION” with CONSULT-III.
2. Touch “START”.
3. Make sure that output voltage of A/T fluid temperature sensor is within the range below.
FLUID TEMP SE: 0.4 - 1.5 V
If out of range, drive the vehicle to decrease the voltage (warm up the fluid) or stop engine to increase the voltage (cool down the fluid).
4. Select “3RD GR FNCTN P0733” of “DTC & SRT CONFIRMATION” mode for “TRANSMISSION” with CONSULT-III and touch “START”.
5. Accelerate vehicle to 60 to 75 km/h (37 to 47 MPH) under the following conditions and release the accelerator pedal completely.
THROTTLE POSI: Less than 1.0/8 (at all times during step 4)
SLCT LVR POSI: “D” position

P0733 3GR INCORRECT RATIO

< SERVICE INFORMATION >

- **Make sure that "GEAR" shows "4" after releasing pedal.**
- 6. Depress accelerator pedal steadily with 3.5/8 - 4.5/8 of "THROTTLE POSI" from a speed of 60 to 75 km/h (37 to 47 MPH) until "TESTING" changes to "STOP VEHICLE" or "COMPLETED". (It will take approximately 3 seconds.)
If the check result NG appears on CONSULT-III screen, go to [AT-116, "Diagnosis Procedure"](#).
If "STOP VEHICLE" appears on CONSULT-III screen, go to following step.
- **Make sure that "GEAR" shows "3" when depressing accelerator pedal with 3.5/8 - 4.5/8 of "THROTTLE POSI".**
- **If "TESTING" does not appear on CONSULT-III for a long time, select "SELF-DIAG RESULTS" for "TRANSMISSION". In case a DTC other than "P0733 3GR INCORRECT RATIO" is shown, refer to [AT-77, "CONSULT-III Function \(TRANSMISSION\)"](#).**
- 7. Stop vehicle.
- 8. Follow the instruction displayed. (Check for normal shifting referring to the table below.)

Vehicle condition	Gear on actual transmission shift pattern when screen is changed to 1 → 2 → 3 → 4
No malfunction exists.	1 → 2 → 3 → 4
Malfunction for "3GR INCORRECT RATIO" exists.	1 → 1 → 4 → 4

- 9. Make sure that "OK" is displayed. (If "NG" is displayed, refer to "Diagnostic Procedure".)
Refer to [AT-116, "Diagnosis Procedure"](#).
Refer to [AT-64, "Vehicle Speed at Which Gear Shifting Occurs"](#).

WITH GST

Follow the procedure "WITH CONSULT-III".

Diagnosis Procedure

INFOID:000000005928157

1. CHECK VALVE RESISTANCE

- 1. Remove control valve assembly. Refer to [AT-222, "Control Valve Assembly and Accumulators"](#).
 - Shift solenoid valve A
 - Shift solenoid valve B
- 2. Check resistance between terminal cord assembly harness connector terminals and ground. Refer to [AT-139, "Wiring Diagram - AT - SSV/A"](#) and [AT-144, "Wiring Diagram - AT - SSV/B"](#).

Solenoid valve	Connector	Terminal	Resistance (Approx.)
Shift solenoid valve A	F30	2 - Ground	20 - 30 Ω
Shift solenoid valve B		1 - Ground	5 - 20 Ω

OK or NG

- OK >> GO TO 2.
- NG >> Repair or replace shift solenoid valve assembly.

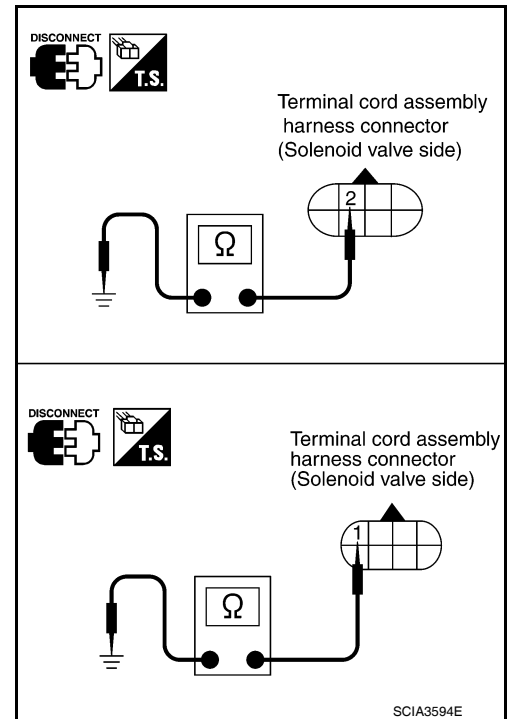

2. CHECK VALVE OPERATION

- 1. Remove control valve assembly. Refer to [AT-222, "Control Valve Assembly and Accumulators"](#).
 - Shift solenoid valve A
 - Shift solenoid valve B

P0733 3GR INCORRECT RATIO

< SERVICE INFORMATION >

2. Check solenoid valve by listening for its operating sound while applying battery voltage to the terminals and ground. Refer to [AT-139. "Wiring Diagram - AT - SSV/A"](#) and [AT-144. "Wiring Diagram - AT - SSV/B"](#).

OK or NG

- OK >> GO TO 3.
NG >> Repair or replace shift solenoid valve assembly.

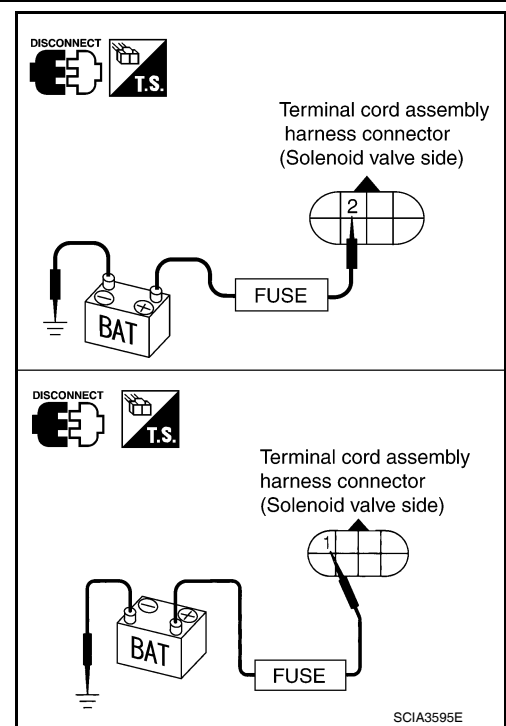

3. CHECK CONTROL VALVE

1. Disassemble control valve assembly. Refer to [AT-281. "Control Valve Assembly"](#).
2. Check to ensure that:
 - Valve, sleeve and plug slide along valve bore under their own weight.
 - Valve, sleeve and plug are free from burrs, dents and scratches.
 - Control valve springs are free from damage, deformation and fatigue.
 - Hydraulic line is free from obstacles.

OK or NG

- OK >> GO TO 4.
NG >> Repair control valve assembly.

4. CHECK DTC

Perform [AT-115. "DTC Confirmation Procedure"](#).

OK or NG

- OK >> **INSPECTION END**
NG >> Check control valve again. If NG, repair or replace control valve assembly.

P0734 4GR INCORRECT RATIO

< SERVICE INFORMATION >

P0734 4GR INCORRECT RATIO

Description

INFOID:000000005928158

- This malfunction will not be detected while the OD OFF indicator lamp is indicating another self-diagnosis malfunction.
- This malfunction is detected when the A/T does not shift into fourth gear position or the torque converter clutch does not lock up as instructed by the TCM. This is not caused by electrical malfunction (circuits open or shorted) but by mechanical malfunction such as control valve sticking, improper solenoid valve operation, malfunctioning oil pump or torque converter clutch, etc.

Gear position	1	2	3	4
Shift solenoid valve A	ON (Closed)	OFF (Open)	OFF (Open)	ON (Closed)
Shift solenoid valve B	ON (Closed)	ON (Closed)	OFF (Open)	OFF (Open)

CONSULT-III Reference Value in Data Monitor Mode

INFOID:000000005928159

Remarks: Specification data are reference values.

Item name	Condition	Display value (Approx.)
LINE PRES DTY	Small throttle opening (Low line pressure) ⇔ Large throttle opening (High line pressure)	0% ⇔ 94%

On Board Diagnosis Logic

INFOID:000000005928160

- This is an OBD-II self-diagnostic item.
- Diagnostic trouble code "P0734 4GR INCORRECT RATIO" with CONSULT-III is detected when A/T cannot be shifted to the 4GR position even if electrical circuit is good.
- This diagnosis monitors actual gear position by checking the torque converter slip ratio calculated by TCM as follows:
Torque converter slip ratio = $A \times C/B$
A: Output shaft revolution signal from output speed sensor
B: Engine speed signal from ECM
C: Gear ratio determined as gear position which TCM supposes
If the actual gear position is much lower than the position (4th) supposed by TCM, the slip ratio will be much less than normal. In case the ratio does not reach the specified value, TCM judges this diagnosis malfunction.
This malfunction will be caused when shift solenoid valve A is stuck open or shift solenoid valve B is stuck closed.
- Gear positions supposed by TCM are as follows.
In case of gear position with no malfunctions: 1, 2, 3 and 4 positions
In case of gear position with shift solenoid valve A stuck open: 2, 2, 3 and 3* positions
In case of gear position with shift solenoid valve B stuck closed: 1, 2, 2 and 1* positions to each gear position above
*: "P0734 4GR INCORRECT RATIO" is detected.

Possible Cause

INFOID:000000005928161

- Shift solenoid valve A
- Shift solenoid valve B
- Line pressure solenoid valve
- Each clutch
- Hydraulic control circuit

DTC Confirmation Procedure

INFOID:000000005928162

CAUTION:

- **Always drive vehicle at a safe speed.**
- **If performing this "DTC Confirmation Procedure" again, always turn ignition switch OFF and wait at least 10 seconds before continuing.**

After the repair, perform the following procedure to confirm the malfunction is eliminated.

P0734 4GR INCORRECT RATIO

< SERVICE INFORMATION >

Ⓜ WITH CONSULT-III

1. Start engine and select "DATA MONITOR" mode for "TRANSMISSION" with CONSULT-III.
2. Touch "START".
3. Make sure that output voltage of A/T fluid temperature sensor is within the range below.
FLUID TEMP SE: 0.4 - 1.5 V
If out of range, drive the vehicle to decrease the voltage (warm up the fluid) or stop engine to increase the voltage (cool down the fluid).
4. Select "4TH GR FNCTN P0734" of "DTC & SRT CONFIRMATION" mode for "TRANSMISSION" with CONSULT-III and touch "START".
5. Accelerate vehicle to 55 to 65 km/h (34 to 40 MPH) under the following conditions and release the accelerator pedal completely.
THROTTLE POSI: Less than 5.5/8 (at all times during step 4)
SLCT LVR POSI: "D" position
- **Make sure that "GEAR" shows "3" after releasing pedal.**
6. Depress accelerator pedal steadily with 1.0/8 - 2.0/8 of "THROTTLE POSI" from a speed of 55 to 65 km/h (34 to 40 MPH) until "TESTING" has turned to "STOP VEHICLE" or "COMPLETED". (It will take approximately 3 seconds.)
If the check result NG appears on CONSULT-III screen, go to [AT-119. "Diagnosis Procedure"](#).
If "STOP VEHICLE" appears on CONSULT-III screen, go to following step.
- **Make sure that "GEAR" shows "4" when depressing accelerator pedal with 1.0/8 - 2.0/8 of "THROTTLE POSI".**
- **If "TESTING" does not appear on CONSULT-III for a long time, select "SELF-DIAG RESULTS" for "TRANSMISSION". In case a DTC other than "P0734 4GR INCORRECT RATIO" is shown, refer to [AT-77. "CONSULT-III Function \(TRANSMISSION\)"](#).**
7. Stop vehicle.
8. Follow the instruction displayed. (Check for normal shifting referring to the table below.)

Vehicle condition	Gear on actual transmission shift pattern when screen is changed to 1 → 2 → 3 → 4
No malfunction exists	1 → 2 → 3 → 4
Malfunction for "4GR INCORRECT RATIO" exists.	2 → 2 → 3 → 3
	1 → 2 → 2 → 1

9. Make sure that "OK" is displayed. (If "NG" is displayed, refer to "Diagnostic Procedure".)
Refer to [AT-119. "Diagnosis Procedure"](#).
Refer to [AT-64. "Vehicle Speed at Which Gear Shifting Occurs"](#).

Ⓜ WITH GST

Follow the procedure "WITH CONSULT-III".

Diagnosis Procedure

INFOID:000000005928163

1. CHECK SHIFT-UP (D3 TO D4)

During [AT-58. "Cruise Test - Part 1"](#).

Does A/T shift from D3 to D4 at the specified speed?

- YES >> GO TO 11.
NO >> GO TO 2.

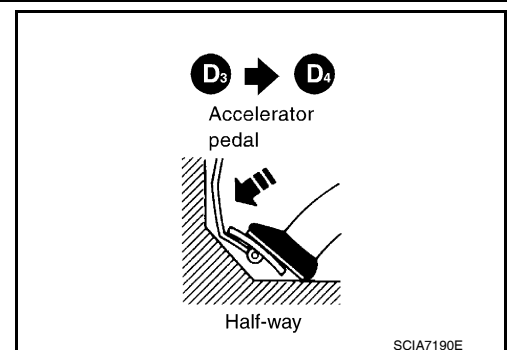

2. CHECK LINE PRESSURE

Perform line pressure test. Refer to [AT-51. "Inspections Before Trouble Diagnosis"](#).

OK or NG

- OK >> GO TO 3.
NG >> GO TO 7.

P0734 4GR INCORRECT RATIO

< SERVICE INFORMATION >

3. CHECK VALVE RESISTANCE

- Remove control valve assembly. Refer to [AT-222, "Control Valve Assembly and Accumulators"](#).
 - Shift solenoid valve A
 - Shift solenoid valve B
- Check resistance between terminal cord assembly harness connector terminals and ground. Refer to [AT-139, "Wiring Diagram - AT - SSV/A"](#) and [AT-144, "Wiring Diagram - AT - SSV/B"](#).

Solenoid valve	Connector	Terminal	Resistance (Approx.)
Shift solenoid valve A	F30	2 - Ground	20 - 30 Ω
Shift solenoid valve B		1 - Ground	5 - 20 Ω

OK or NG

- OK >> GO TO 4.
 NG >> Replace solenoid valve assembly.

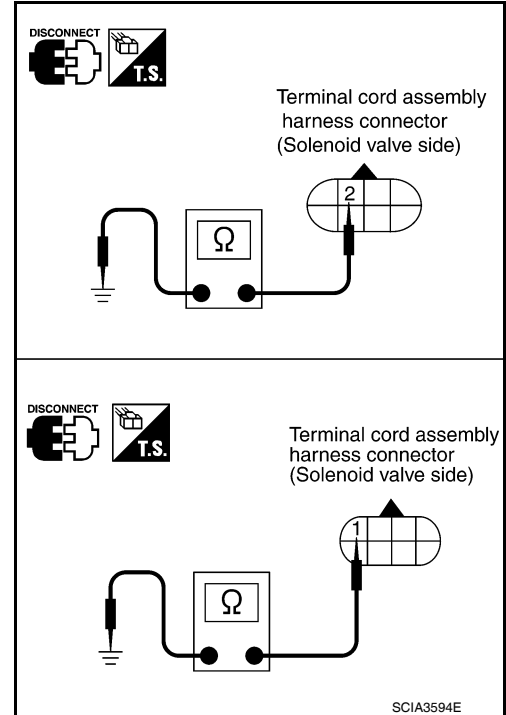

4. CHECK VALVE OPERATION

- Remove control valve assembly. Refer to [AT-222, "Control Valve Assembly and Accumulators"](#).
 - Shift solenoid valve A
 - Shift solenoid valve B
- Check solenoid valve by listening for its operating sound while applying battery voltage to the terminals and ground. Refer to [AT-139, "Wiring Diagram - AT - SSV/A"](#) and [AT-144, "Wiring Diagram - AT - SSV/B"](#).

OK or NG

- OK >> GO TO 5.
 NG >> Replace solenoid valve assembly.

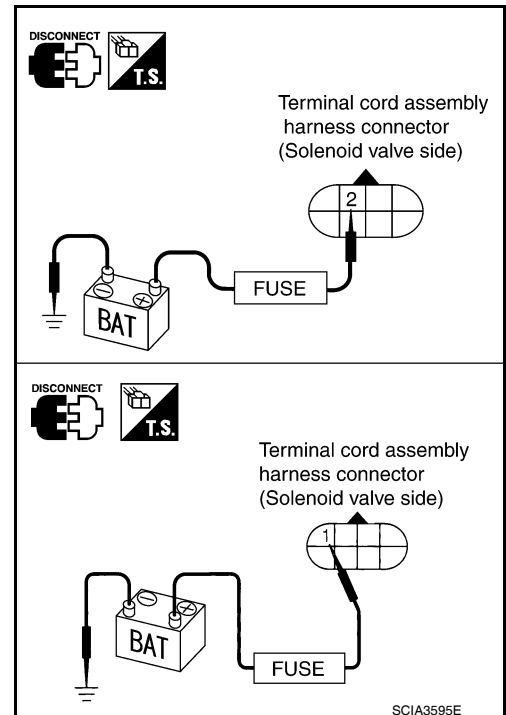

5. CHECK CONTROL VALVE

- Disassemble control valve assembly. Refer to [AT-281, "Control Valve Assembly"](#).
- Check to ensure that:

P0734 4GR INCORRECT RATIO

< SERVICE INFORMATION >

- Valve, sleeve and plug slide along valve bore under their own weight.
- Valve, sleeve and plug are free from burrs, dents and scratches.
- Control valve springs are free from damage, deformation and fatigue.
- Hydraulic line is free from obstacles.

OK or NG

- OK >> GO TO 6.
- NG >> Repair control valve.

6. CHECK SHIFT-UP (D3 TO D4)

During [AT-58, "Cruise Test - Part 1"](#).

Does A/T shift from D3 to D4 at the specified speed?

- YES >> GO TO 11.
- NO >> Check control valve again. Repair or replace control valve assembly.

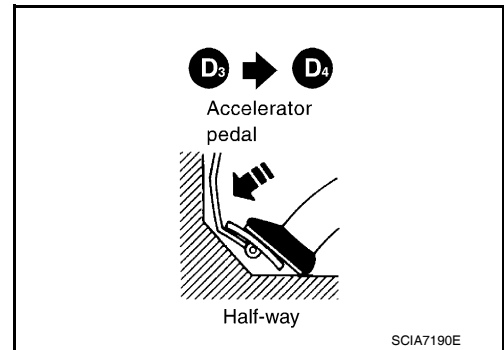

7. CHECK VALVE RESISTANCE

1. Remove control valve assembly. Refer to [AT-222, "Control Valve Assembly and Accumulators"](#).
- Line pressure solenoid valves
2. Check resistance between terminal cord assembly harness connector terminal and ground. Refer to [AT-134, "Wiring Diagram - AT - LPSV"](#).

Solenoid valve	Connector	Terminal	Resistance (Approx.)
Line pressure solenoid valve	F30	4 - Ground	2.5 - 5 Ω

OK or NG

- OK >> GO TO 8.
- NG >> Replace solenoid valve assembly.

8. CHECK VALVE OPERATION

1. Remove control valve assembly. Refer to [AT-222, "Control Valve Assembly and Accumulators"](#).
- Line pressure solenoid valves
2. Check solenoid valve by listening for its operating sound while applying battery voltage to the terminal and ground. Refer to [AT-134, "Wiring Diagram - AT - LPSV"](#).

OK or NG

- OK >> GO TO 9.
- NG >> Replace solenoid valve assembly.

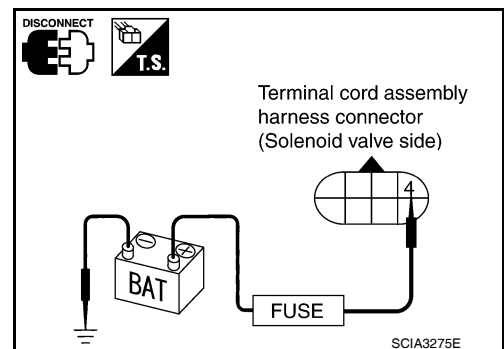
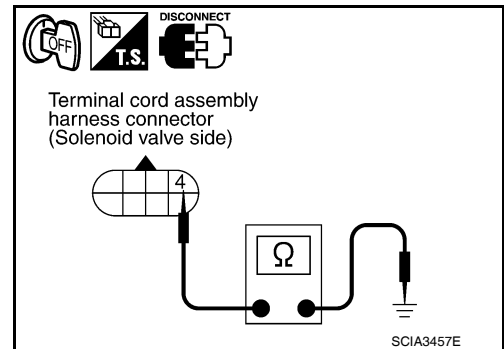

9. CHECK CONTROL VALVE

1. Disassemble control valve assembly. Refer to [AT-281, "Control Valve Assembly"](#).
2. Check line pressure circuit valves for sticking.
 - Pilot valve
 - Shift solenoid valve A
 - Shift solenoid valve B

OK or NG

- OK >> GO TO 10.

P0734 4GR INCORRECT RATIO

< SERVICE INFORMATION >

NG >> Repair control valve.

10. CHECK SHIFT-UP (D3 TO D4)

During [AT-58. "Cruise Test - Part 1"](#).

Does A/T shift from D3 to D4 at the specified speed?

YES >> GO TO 11.

NO >> Check control valve again. Repair or replace control valve assembly.

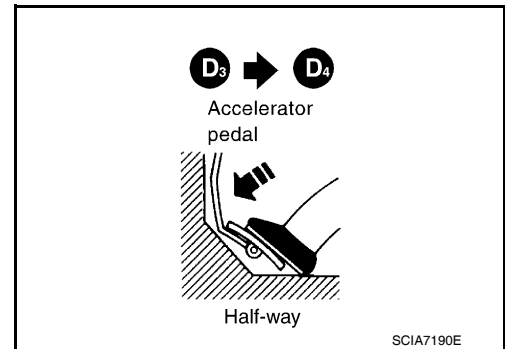

11. CHECK DTC

Perform [AT-118. "DTC Confirmation Procedure"](#).

OK or NG

OK >> **INSPECTION END**

NG >> Perform [AT-58. "Cruise Test - Part 1"](#) again and return to the start point of this test group.

P0740 TORQUE CONVERTER

< SERVICE INFORMATION >

P0740 TORQUE CONVERTER

Description

INFOID:000000005928164

- The torque converter clutch solenoid valve is activated, with the gear in D4 and D3, by the TCM in response to signals sent from the output speed sensor and the ECM (throttle opening). Lock-up piston operation will then be controlled.
- Lock-up operation, however, is prohibited when A/T fluid temperature is too low.
- When the accelerator pedal is depressed (less than 2/8) on lock-up condition, the engine speed should not change abruptly. If there is an abrupt change in engine speed, there is no lock-up.

CONSULT-III Reference Value in Data Monitor Mode

INFOID:000000005928165

Remarks: Specification data are reference values.

Item name	Condition	Display value (Approx)
TCC S/V DUTY	Lock-up OFF ↔ Lock-up ON	4% ↔ 94%

On Board Diagnosis Logic

INFOID:000000005928166

- This is an OBD-II self-diagnostic item.
- Diagnostic trouble code "P0740 T/C CLUTCH SOL" with CONSULT-III or 7th judgement flicker without CONSULT-III is detected when TCM detects an improper voltage drop while it tries to operate solenoid valve.

Possible Cause

INFOID:000000005928167

- Torque converter clutch solenoid valve
- Harness or connector
(The solenoid circuit is open or shorted.)

DTC Confirmation Procedure

INFOID:000000005928168

CAUTION:

- **Always drive vehicle at a safe speed.**
- **If performing this "DTC Confirmation Procedure" again, always turn ignition switch OFF and wait at least 10 seconds before continuing.**

After the repair, perform the following procedure to confirm the malfunction is eliminated.

① WITH CONSULT-III

1. Turn ignition switch ON. (Do not start engine.)
2. Select "DATA MONITOR" mode for "TRANSMISSION" with CONSULT-III and wait at least 1 second.
3. Touch "START".
4. Start engine and maintain the following conditions for at least 5 consecutive seconds.
VEHICLE SPEED: 80 km/h (50 MPH) or more
THROTTLE POSI: 0.5/8 - 1.0/8
SLCT LVR POSI: "D" position
Driving location: Driving the vehicle uphill (increased engine load) will help maintain the driving conditions required for this test.
5. If the check result is NG, go to [AT-125, "Diagnosis Procedure"](#).

② WITH GST

Follow the procedure "WITH CONSULT-III".

③ WITHOUT CONSULT-III

1. Start engine.
2. Drive vehicle in D1→ D2→ D3→ D4→ D4 lock-up position.
3. Perform self-diagnosis. Refer to [AT-82, "Diagnosis Procedure without CONSULT-III"](#).
4. If the check result is NG, go to [AT-125, "Diagnosis Procedure"](#).

P0740 TORQUE CONVERTER

< SERVICE INFORMATION >

Wiring Diagram - AT - TCV

INFOID:000000005928169

AT-TCV-01

— : DETECTABLE LINE FOR DTC
 - - - : NON-DETECTABLE LINE FOR DTC

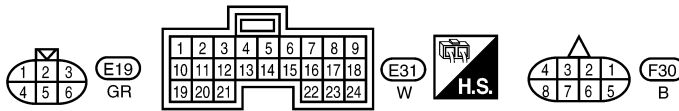
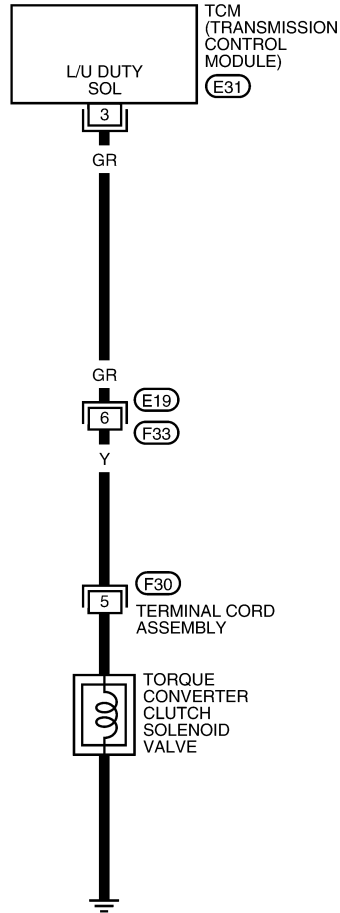

BCWA0653E

TCM TERMINALS AND REFERENCE VALUES

Refer to [AT-75. "TCM Terminal and Reference Value"](#).

P0740 TORQUE CONVERTER

< SERVICE INFORMATION >

Diagnosis Procedure

INFOID:000000005928170

1. CHECK INPUT SIGNAL

With CONSULT-III

1. Start engine.
2. Select "MAIN SIGNALS" in "DATA MONITOR" mode for "TRANSMISSION" with CONSULT-III.
3. Read out the value of "TCC S/V DUTY" while driving. Check the value changes according to driving speed.

Monitor item	Condition	Display value (Approx)
TCC S/V DUTY	Lock-up OFF ⇔ Lock-up ON	4 % ⇔ 94 %

Without CONSULT-III

1. Start engine.
2. Check voltage between TCM connector terminal and ground.

Name	Connector	Terminal	Condition	Judgement standard (Approx.)
Torque converter clutch solenoid valve	E31	3 - Ground	When A/T performs lock-up.	8 - 15 V
			When A/T does not perform lock-up.	0 V

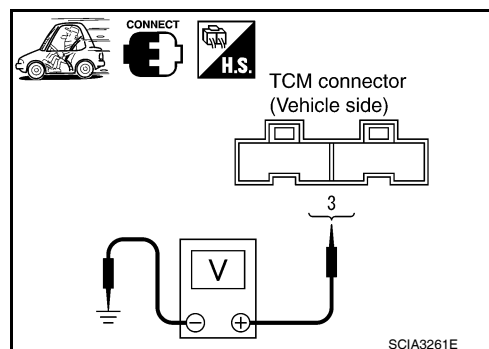

OK or NG

- OK >> GO TO 5.
 NG >> GO TO 2.

2. CHECK TORQUE CONVERTER CLUTCH SOLENOID VALVE CIRCUIT

1. Turn ignition switch OFF.
2. Disconnect TCM connector.
3. Check resistance between TCM connector terminal and ground.

Solenoid Valve	Connector	Terminal	Resistance (Approx.)
Torque converter clutch solenoid valve	E31	3 - Ground	5 - 20 Ω

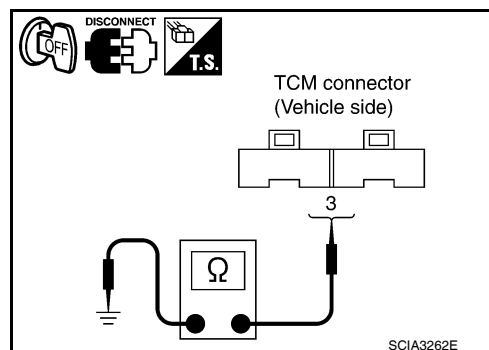

OK or NG

- OK >> GO TO 5.
 NG >> GO TO 3.

3. CHECK HARNESS BETWEEN TCM AND TERMINAL CORD ASSEMBLY HARNESS CONNECTOR

1. Turn ignition switch OFF.
2. Disconnect terminal cord assembly harness connector and TCM connector.

P0740 TORQUE CONVERTER

< SERVICE INFORMATION >

3. Check continuity between terminal cord assembly harness connector terminal and TCM connector terminal.

Item	Connector	Terminal	Continuity
TCM	E31	3	Yes
Terminal cord assembly harness connector	F30	5	

4. If OK, check harness for short to ground and short to power.
5. If OK, check continuity between ground and transaxle assembly.
6. Reinstall any part removed.

OK or NG

OK >> GO TO 4.

NG >> Repair open circuit or short to ground or short to power in harness or connectors.

4. CHECK VALVE RESISTANCE

1. Turn ignition switch OFF.
2. Disconnect terminal cord assembly connector in engine room.
3. Check resistance between terminal cord assembly harness connector terminal and ground.

Solenoid valve	Connector	Terminal	Resistance (Approx.)
Torque converter clutch solenoid valve	F30	5 - Ground	5 - 20 Ω

OK or NG

OK >> GO TO 5.

NG >> Repair or replace damaged parts.

5. CHECK DTC

Perform [AT-123, "DTC Confirmation Procedure"](#) .

OK or NG

OK >> **INSPECTION END**

NG >> GO TO 6.

6. CHECK TCM

1. Check TCM input/output signal. Refer to [AT-75, "TCM Terminal and Reference Value"](#) .
2. If NG, recheck TCM pin terminals for damage or loose connection with harness connector.

OK or NG

OK >> **INSPECTION END**

NG >> Repair or replace damaged parts.

Component Inspection

INFOID:000000005928171

TORQUE CONVERTER CLUTCH SOLENOID VALVE

- For removal, refer to [AT-222, "Control Valve Assembly and Accumulators"](#) .

Resistance Check

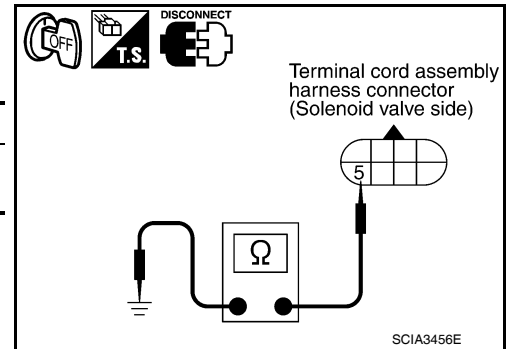
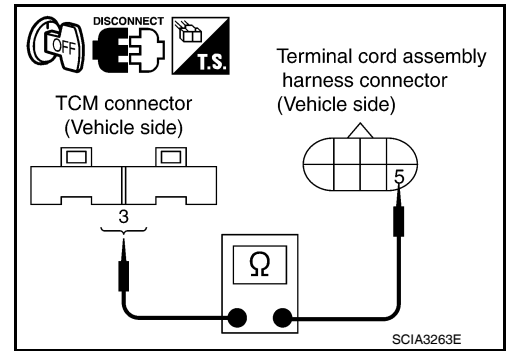

P0740 TORQUE CONVERTER

< SERVICE INFORMATION >

- Check resistance between terminal and ground.

Solenoid valve	Connector	Terminal	Resistance (Approx.)
Torque converter clutch solenoid valve	F30	5 - Ground	5 - 20 Ω

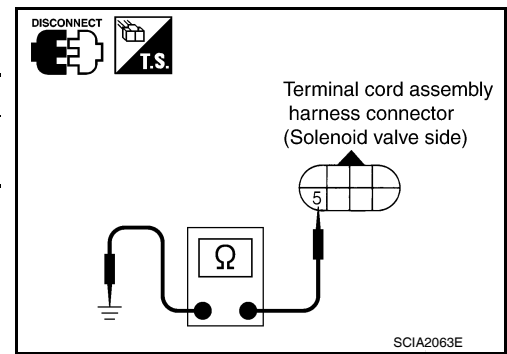

Operation Check

- Check solenoid valve by listening for its operating sound while applying battery voltage to the terminal and ground.

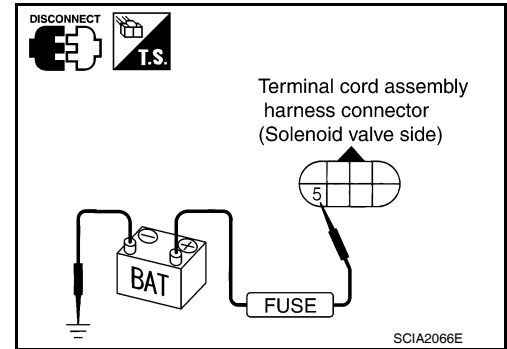

A
B
AT
D
E
F
G
H
I
J
K
L
M
N
O
P

P0744 TORQUE CONVERTER

< SERVICE INFORMATION >

P0744 TORQUE CONVERTER

Description

INFOID:000000005928172

- This malfunction will not be detected while the OD OFF indicator lamp is indicating another self-diagnosis malfunction.
- This malfunction is detected when the A/T does not shift into fourth gear position or the torque converter clutch does not lock-up as instructed by the TCM. This is not caused by electrical malfunction (circuits open or shorted) but by mechanical malfunction such as control valve sticking, improper solenoid valve operation, malfunctioning oil pump or torque converter clutch, etc.

CONSULT-III Reference Value in Data Monitor Mode

INFOID:000000005928173

Remarks: Specification data are reference values.

Item name	Condition	Display value (Approx)
TCC S/V DUTY	Lock-up OFF ↔ Lock-up ON	4% ↔ 94%

On Board Diagnosis Logic

INFOID:000000005928174

- This is an OBD-II self-diagnostic item.
- Diagnostic trouble code “P0744 T/C CLUTCH FNCTN” with CONSULT-III is detected when A/T cannot perform lock-up even if electrical circuit is good.
- This diagnosis monitors actual gear position by checking the torque converter slip ratio calculated by TCM as follows:
Torque converter slip ratio = $A \times C/B$
A: Output shaft revolution signal from output speed sensor
B: Engine speed signal from ECM
C: Gear ratio determined as gear position which TCM supposes
If the actual gear position is much lower than the position (4th) supposed by TCM, the slip ratio will be much less than normal. In case the ratio does not reach the specified value, TCM judges this diagnosis malfunction.
This malfunction will be caused when shift solenoid valve B is stuck closed.
- Gear positions supposed by TCM are as follows.
In case of gear position with no malfunctions: 1, 2, 3 and 4 positions
In case of gear position with shift solenoid valve B stuck closed: 1, 2, 2 and 1* positions to each gear position above
*: “P0744 T/C CLUTCH FNCTN” is detected.

Possible Cause

INFOID:000000005928175

- Line pressure solenoid valve
- Torque converter clutch solenoid valve
- Each clutch
- Hydraulic control circuit

DTC Confirmation Procedure

INFOID:000000005928176

CAUTION:

- **Always drive vehicle at a safe speed.**
- **If performing this “DTC Confirmation Procedure” again, always turn ignition switch OFF and wait at least 10 seconds before continuing.**

After the repair, perform the following procedure to confirm the malfunction is eliminated.

④ WITH CONSULT-III

1. Start engine and select “DATA MONITOR” mode for “TRANSMISSION” with CONSULT-III.
2. Touch “START”.
3. Make sure that output voltage of A/T fluid temperature sensor is within the range below.
FLUID TEMP SE: 0.4 - 1.5 V
If out of range, drive vehicle to decrease voltage (warm up the fluid) or stop engine to increase voltage (cool down the fluid).
4. Select “TCC S/V FNCTN P0744” of “DTC & SRT CONFIRMATION” mode for “TRANSMISSION” with CONSULT-III and touch “START”.

P0744 TORQUE CONVERTER

< SERVICE INFORMATION >

5. Accelerate vehicle to more than 80 km/h (50 MPH) and maintain the following conditions continuously until "TESTING" has turned to "COMPLETE". (It will take approximately 30 seconds after "TESTING" shows.)

THROTTLE POSI: 1.0/8 - 2.0/8 (at all times during step 4)

SLCT LVR POSI: "D" position

TCC S/V DUTY: More than 94%

VEHICLE SPEED: Constant speed of more than 80 km/h (50 MPH)

- Make sure that "GEAR" shows "4".
 - For shift schedule, refer to [AT-64, "Vehicle Speed at Which Gear Shifting Occurs"](#).
 - If "TESTING" does not appear on CONSULT-III for a long time, select "SELF-DIAG RESULTS". In case a DTC other than "P0744 T/C CLUTCH FNCTN" is shown, refer to [AT-77, "CONSULT-III Function \(TRANSMISSION\)"](#).
6. Make sure that "OK" is displayed. (If "NG" is displayed, refer to "DIAGNOSTIC PROCEDURE".)
Refer to [AT-129, "Diagnosis Procedure"](#).
Refer to [AT-64, "Vehicle Speed at Which Lock-up Occurs/Releases"](#).

WITH GST

Follow the procedure "WITH CONSULT-III".

Diagnosis Procedure

INFOID:000000005928177

1. CHECK SHIFT-UP (D3 TO D4)

During [AT-58, "Cruise Test - Part 1"](#).

Does A/T shift from D3 to D4 at the specified speed?

- YES >> GO TO 11.
NO >> GO TO 2.

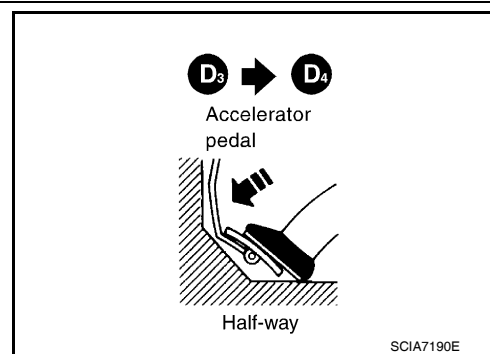

2. CHECK LINE PRESSURE

Perform line pressure test. Refer to [AT-51, "Inspections Before Trouble Diagnosis"](#).

OK or NG

- OK >> GO TO 3.
NG >> GO TO 6.

3. CHECK CONTROL VALVE

1. Disassemble control valve assembly. Refer to [AT-281, "Control Valve Assembly"](#).
2. Check to ensure that:
 - Valve, sleeve and plug slide along valve bore under their own weight.
 - Valve, sleeve and plug are free from burrs, dents and scratches.
 - Control valve springs are free from damage, deformation and fatigue.
 - Hydraulic line is free from obstacles.

OK or NG

- OK >> GO TO 4.
NG >> Repair control valve.

4. CHECK SHIFT-UP (D3 TO D4)

P0744 TORQUE CONVERTER

< SERVICE INFORMATION >

During [AT-58, "Cruise Test - Part 1"](#).

Does A/T shift from D3 to D4 at the specified speed?

YES >> GO TO 5.

NO >> Check control valve again. Repair or replace control valve assembly.

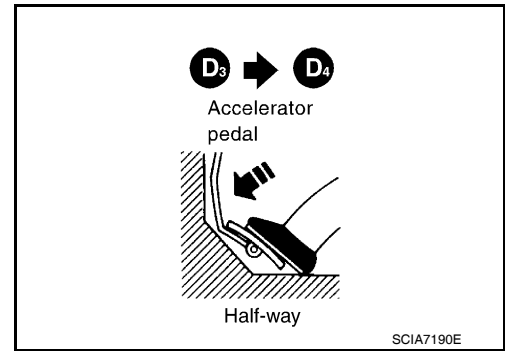

5. CHECK DTC

Perform [AT-128, "DTC Confirmation Procedure"](#).

OK or NG

OK >> **INSPECTION END**

NG >> GO TO 11. Check for proper lock-up.

6. CHECK VALVE RESISTANCE

- Remove control valve assembly. Refer to [AT-222, "Control Valve Assembly and Accumulators"](#).
 - Line pressure solenoid valve
- Check resistance between terminal cord assembly harness connector terminal and ground. Refer to [AT-134, "Wiring Diagram - AT - LPSV"](#).

Solenoid valve	Connector	Terminal	Resistance (Approx.)
Line pressure solenoid valve	F30	4 - Ground	2.5 - 5 Ω

OK or NG

OK >> GO TO 7.

NG >> Replace solenoid valve assembly.

7. CHECK VALVE OPERATION

- Remove control valve assembly. Refer to [AT-222, "Control Valve Assembly and Accumulators"](#).
 - Line pressure solenoid valve
- Check solenoid valve by listening for its operating sound while applying battery voltage to the terminal and ground. Refer to [AT-134, "Wiring Diagram - AT - LPSV"](#).

OK or NG

OK >> GO TO 8.

NG >> Replace solenoid valve assembly.

8. CHECK CONTROL VALVE

- Disassemble control valve assembly. Refer to [AT-281, "Control Valve Assembly"](#).
- Check line pressure circuit valves for sticking.
 - Pressure regulator valve
 - Pilot valve
 - Pressure modifier valve

OK or NG

OK >> GO TO 9.

NG >> Repair control valve.

9. CHECK SHIFT-UP (D3 TO D4)

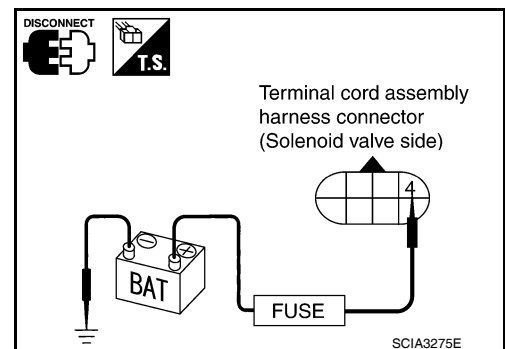
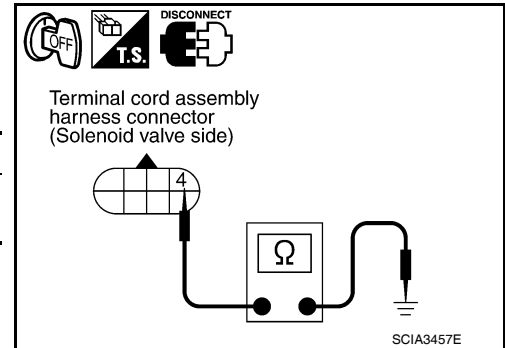

P0744 TORQUE CONVERTER

< SERVICE INFORMATION >

During [AT-58. "Cruise Test - Part 1"](#).

Does A/T shift from D3 to D4 at the specified speed?

- YES >> GO TO 10.
- NO >> Check control valve again. Repair or replace control valve assembly.

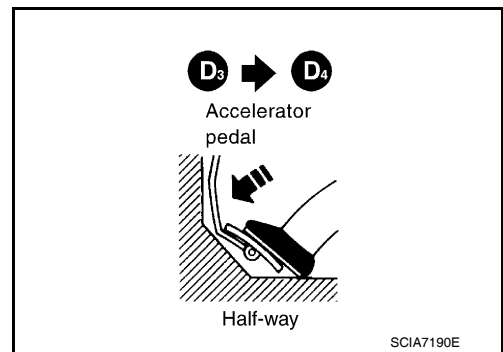

10. CHECK DTC

Perform [AT-128. "DTC Confirmation Procedure"](#).

OK or NG

- OK >> **INSPECTION END**
- NG >> GO TO 11. Check for proper lock-up.

11. CHECK LOCK-UP

During [AT-58. "Cruise Test - Part 1"](#).

A/T perform lock-up at the specified speed?

- YES >> Perform "Cruise test — Part 1" again and return to the start point of this test group.
- NO >> GO TO 12.

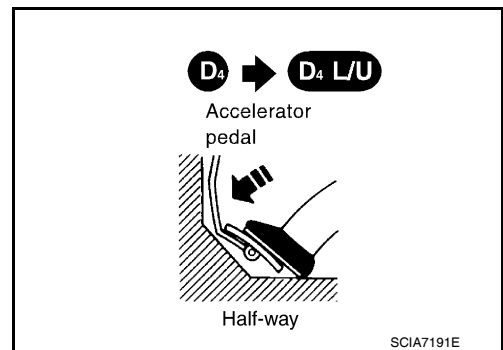

12. CHECK VALVE RESISTANCE

1. Remove control valve assembly. Refer to [AT-222. "Control Valve Assembly and Accumulators"](#).
- Torque converter clutch solenoid valve
2. Check resistance between terminal cord assembly harness connector terminal and ground. Refer to [AT-124. "Wiring Diagram - AT - TCV"](#).

Solenoid valve	Connector	Terminal	Resistance (Approx.)
Torque converter clutch solenoid valve	F30	5 - Ground	5 - 20 Ω

OK or NG

- OK >> GO TO 13.
- NG >> Replace solenoid valve assembly.

13. CHECK VALVE OPERATION

1. Remove control valve assembly. Refer to [AT-222. "Control Valve Assembly and Accumulators"](#).
- Torque converter clutch solenoid valve

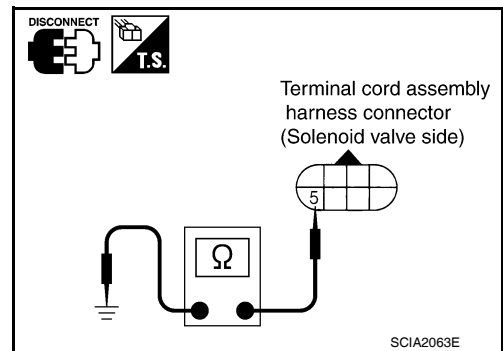

P0744 TORQUE CONVERTER

< SERVICE INFORMATION >

2. Check solenoid valve by listening for its operating sound while applying battery voltage to the terminal and ground. Refer to [AT-124, "Wiring Diagram - AT - TCV"](#).

OK or NG

- OK >> GO TO 14.
NG >> Replace solenoid valve assembly.

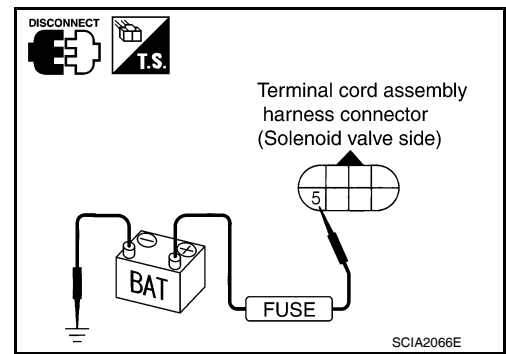

14. CHECK CONTROL VALVE

1. Disassemble control valve assembly. Refer to [AT-281, "Control Valve Assembly"](#).
2. Check control valves for sticking.
 - Torque converter clutch control valve
 - Torque converter clutch relief valve

OK or NG

- OK >> GO TO 15.
NG >> Repair control valve.

15. CHECK LOCK-UP

During [AT-58, "Cruise Test - Part 1"](#).

A/T perform lock-up at the specified speed?

- YES >> GO TO 16.
NO >> Check control valve again. Repair or replace control valve assembly.

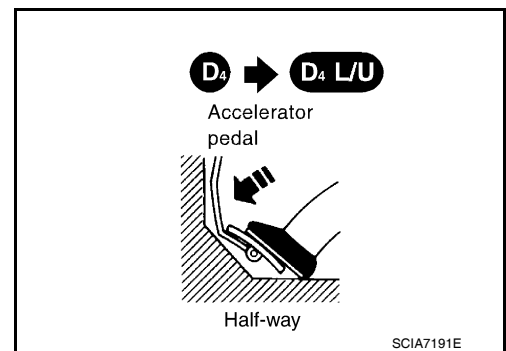

16. CHECK DTC

Perform [AT-128, "DTC Confirmation Procedure"](#).

OK or NG

- OK >> **INSPECTION END**
NG >> Perform "Cruise test — Part 1" again and return to the start point of this test group.

P0745 PRESSURE CONTROL SOLENOID A

< SERVICE INFORMATION >

P0745 PRESSURE CONTROL SOLENOID A

Description

INFOID:000000005928178

The line pressure solenoid valve regulates the oil pump discharge pressure to suit the driving condition in response to signals sent from the TCM.

The line pressure duty cycle value is not constant when the closed throttle position switch is ON. To confirm the line pressure duty cycle at low-pressure, the accelerator (throttle) should be open until the closed throttle position switch is OFF.

CONSULT-III Reference Value in Data Monitor Mode

INFOID:000000005928179

Remarks: Specification data are reference values.

Item name	Condition	Display value (Approx.)
LINE PRES DTY	Small throttle opening (Low line pressure) ↔ Large throttle opening (High line pressure)	0% ↔ 94%

On Board Diagnosis Logic

INFOID:000000005928180

- This is an OBD-II self-diagnostic item.
- Diagnostic trouble code "P0745 PC SOLENOID A" with CONSULT-III or 11th judgement flicker without CONSULT-III is detected when TCM detects an improper voltage drop while it tries to operate the solenoid valve.

Possible Cause

INFOID:000000005928181

- Harness or connector
(The solenoid circuit is open or shorted.)
- Line pressure solenoid valve

DTC Confirmation Procedure

INFOID:000000005928182

CAUTION:

If performing this "DTC Confirmation Procedure" again, always turn ignition switch OFF and wait at least 10 seconds before continuing.

After the repair, perform the following procedure to confirm the malfunction is eliminated.

WITH CONSULT-III

1. Turn ignition switch ON and select "DATA MONITOR" mode for "TRANSMISSION" with CONSULT-III.
2. Touch "START".
3. Depress accelerator pedal completely and wait at least 1 second.
4. If the check result is NG, go to [AT-135. "Diagnosis Procedure"](#).

WITH GST

Follow the procedure "WITH CONSULT-III".

WITHOUT CONSULT-III

1. Start engine.
2. With brake pedal depressed, shift the lever from "P" → "N" → "D" → "N" → "P" positions.
3. Perform self-diagnosis. Refer to [AT-82. "Diagnosis Procedure without CONSULT-III"](#).
4. If the check result is NG, go to [AT-135. "Diagnosis Procedure"](#).

P0745 PRESSURE CONTROL SOLENOID A

< SERVICE INFORMATION >

Wiring Diagram - AT - LPSV

INFOID:000000005928183

AT-LPSV-01

— : DETECTABLE LINE FOR DTC
 - - - : NON-DETECTABLE LINE FOR DTC

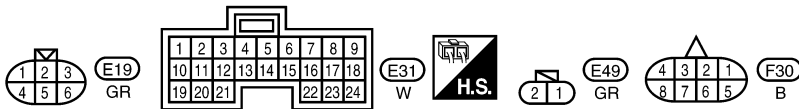
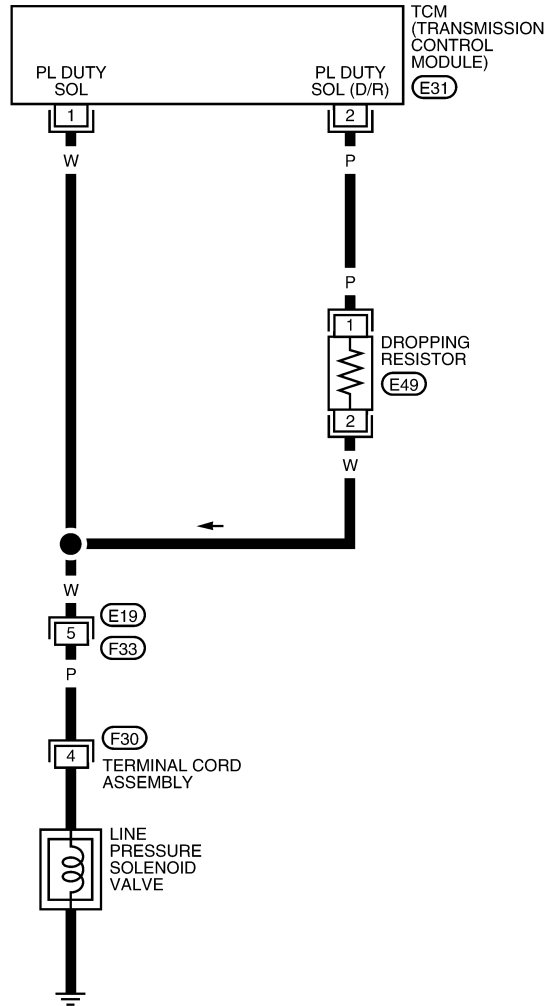

BCWA0654E

TCM TERMINALS AND REFERENCE VALUES
 Refer to [AT-75, "TCM Terminal and Reference Value"](#).

P0745 PRESSURE CONTROL SOLENOID A

< SERVICE INFORMATION >

Diagnosis Procedure

INFOID:000000005928184

1. CHECK INPUT SIGNAL

With CONSULT-III

1. Turn ignition switch ON. (Do not start engine.)
2. Select "MAIN SIGNALS" in "DATA MONITOR" mode for "TRANSMISSION" with CONSULT-III.
3. Read out the value of "LINE PRES DTY" while driving. Check the value changes according to driving speed.

Item name	Condition	Display value
LINE PRES DTY	Small throttle opening (Low line pressure) ↔ Large throttle opening (High line pressure)	0 % ↔ 94 %

Without CONSULT-III

1. Turn ignition switch ON. (Do not start engine.)
2. Check voltage between TCM connector terminals and ground.

Item	Connector	Terminal	Condition	Judgment standard (Approx.)
Line pressure solenoid valve	E31	1 - Ground	When releasing accelerator pedal after warming up engine.	1.5 - 3.0 V
			When depressing accelerator pedal fully after warming up engine.	0 V
Line pressure solenoid valve (with dropping resistor)	E31	2 - Ground	When releasing accelerator pedal after warming up engine.	4 - 14 V
			When depressing accelerator pedal fully after warming up engine.	0 V

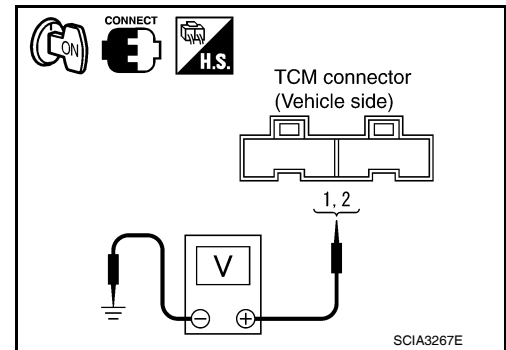

OK or NG

- OK >> GO TO 5.
NG >> GO TO 2.

2. CHECK DROPPING RESISTOR

1. Turn ignition switch OFF.
2. Disconnect dropping resistor harness connector in engine room.
3. Check resistance between terminals.

Item	Connector	Terminal	Resistance (Approx.)
Dropping resistor	E49	1 - 2	12 Ω

OK or NG

- OK >> GO TO 3.
NG >> Repair or replace damaged parts.

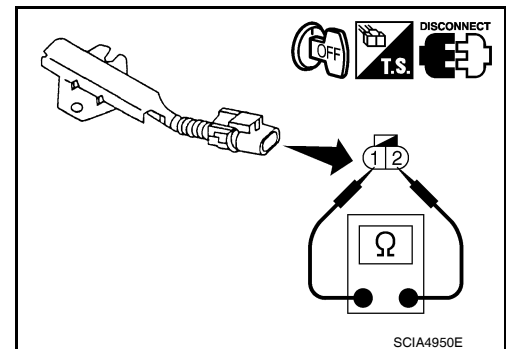

3. CHECK VALVE RESISTANCE

1. Turn ignition switch OFF.
2. Disconnect terminal cord assembly connector in engine room.

P0745 PRESSURE CONTROL SOLENOID A

< SERVICE INFORMATION >

3. Check resistance between terminal cord assembly harness connector terminal and ground.

Solenoid valve	Connector	Terminal	Resistance (Approx.)
Line pressure solenoid valve	F30	4 - Ground	2.5 - 5.0 Ω

OK or NG

- OK >> GO TO 4.
- NG >> Repair or replace damaged parts.

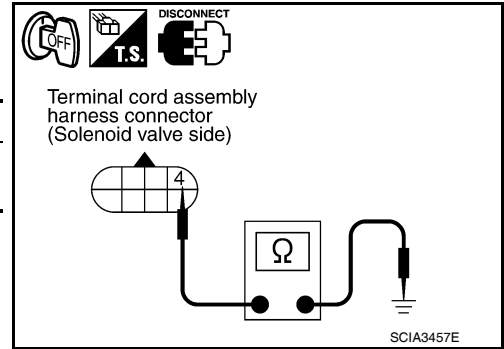

4. CHECK HARNESS BETWEEN TCM AND TERMINAL CORD ASSEMBLY HARNESS CONNECTOR

1. Turn ignition switch OFF.
2. Disconnect terminal cord assembly harness connector and TCM connector.
3. Check continuity between terminal cord assembly harness connector terminal and TCM connector terminal.

Item	Connector	Terminal	Continuity
TCM	E31	1	Yes
Terminal cord assembly harness connector	F30	4	

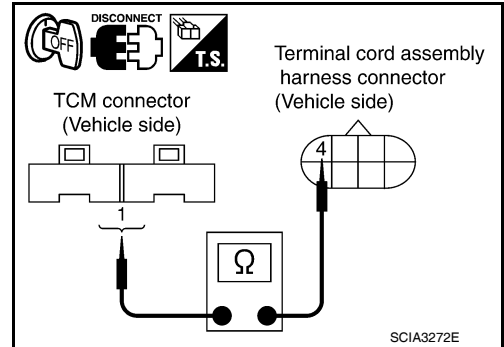

4. Check continuity between terminal cord assembly harness connector terminal and dropping resistor harness connector terminal.

Item	Connector	Terminal	Continuity
Dropping resistor harness connector	E49	2	Yes
Terminal cord assembly harness connector	F30	4	

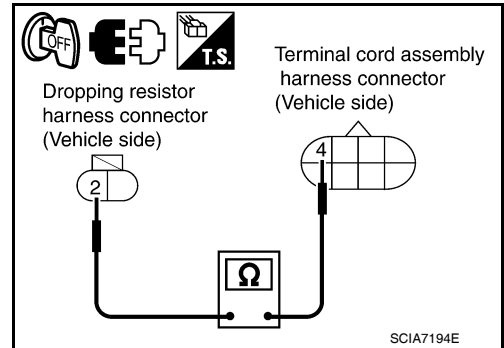

5. Check continuity between dropping resistor harness connector terminal and TCM connector terminal.

Item	Connector	Terminal	Continuity
TCM	E31	2	Yes
Dropping resistor harness connector	E49	1	

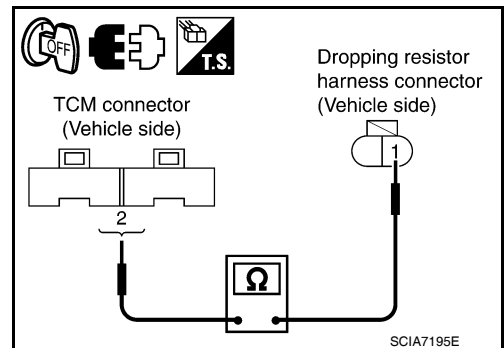

6. If OK, check harness for short to ground and short to power.
7. If OK, check continuity between ground and transaxle assembly.
8. Reinstall any part removed.

OK or NG

- OK >> GO TO 5.
- NG >> Repair open circuit or short to ground or short to power in harness or connectors.

5. CHECK DTC

Perform [AT-133. "DTC Confirmation Procedure"](#) .

OK or NG

- OK >> **INSPECTION END**

P0745 PRESSURE CONTROL SOLENOID A

< SERVICE INFORMATION >

NG >> GO TO 6.

6. CHECK TCM

1. Check TCM input/output signal. Refer to [AT-75, "TCM Terminal and Reference Value"](#).
2. If NG, recheck TCM pin terminals for damage or loose connection with harness connector.

OK or NG

OK >> **INSPECTION END**

NG >> Repair or replace damaged parts.

Component Inspection

INFOID:000000005928185

LINE PRESSURE SOLENOID VALVE

- For removal, refer to [AT-222, "Control Valve Assembly and Accumulators"](#).

Resistance Check

- Check resistance between terminal and ground.

Solenoid valve	Connector	Terminal	Resistance (Approx.)
Line pressure solenoid valve	F30	4 - Ground	2.5 - 5 Ω

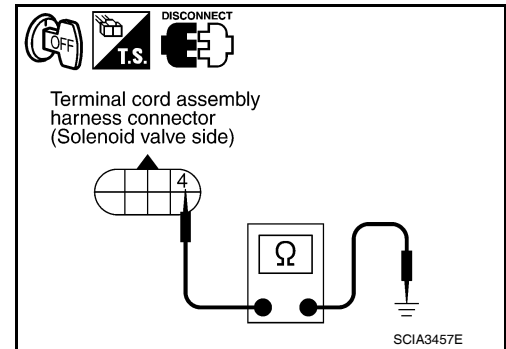

Operation Check

- Check solenoid valve by listening for its operating sound while applying battery voltage to the terminal and ground.

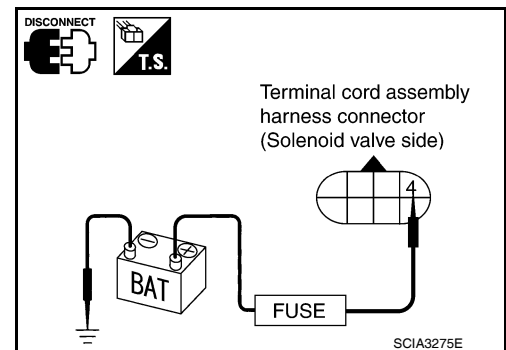

DROPPING RESISTOR

- Check resistance between terminals.

Item	Connector	Terminal	Resistance (Approx.)
Dropping resistor	E49	1 - 2	12 Ω

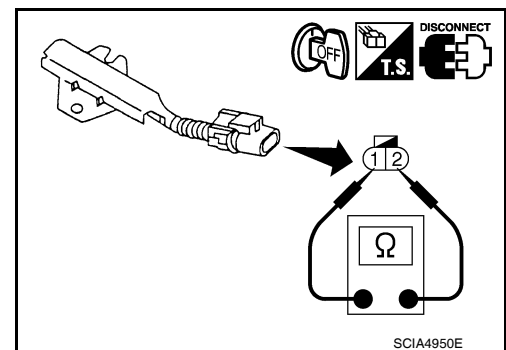

P0750 SHIFT SOLENOID A

< SERVICE INFORMATION >

P0750 SHIFT SOLENOID A

Description

INFOID:000000005928186

Shift solenoid valves A and B are turned ON or OFF by the TCM in response to signals sent from the transmission range switch, vehicle speed and ECM (throttle opening). Gears will then be shifted to the optimum position.

Gear position	1	2	3	4
Shift solenoid valve A	ON (Closed)	OFF (Open)	OFF (Open)	ON (Closed)
Shift solenoid valve B	ON (Closed)	ON (Closed)	OFF (Open)	OFF (Open)

CONSULT-III Reference Value in Data Monitor Mode

INFOID:000000005928187

Item name	Condition	Display value
SHIFT S/V A	When shift solenoid valve A operates. (When driving in "D1" or "D4".)	ON
	When shift solenoid valve A does not operate. (When driving in "D2" or "D3".)	OFF

On Board Diagnosis Logic

INFOID:000000005928188

- This is an OBD-II self-diagnostic item.
- Diagnostic trouble code "P0750 SHIFT SOLENOID A" with CONSULT-III or 4th judgement flicker without CONSULT-III is detected when TCM detects an improper voltage drop when it tries to operate the solenoid valve.

Possible Cause

INFOID:000000005928189

- Harness or connector
(The solenoid circuit is open or shorted.)
- Shift solenoid valve A

DTC Confirmation Procedure

INFOID:000000005928190

CAUTION:

- **Always drive vehicle at a safe speed.**
- **If performing this "DTC Confirmation Procedure" again, always turn ignition switch OFF and wait at least 10 seconds before continuing.**

After the repair, perform the following procedure to confirm the malfunction is eliminated.

④ WITH CONSULT-III

1. Turn ignition switch ON and select "DATA MONITOR" mode for "TRANSMISSION" with CONSULT-III.
2. Touch "START".
3. Start engine.
4. Drive vehicle in "D" position and allow the transaxle to shift 1 → 2 ("GEAR").
5. If the check result is NG, go to [AT-140, "Diagnosis Procedure"](#).

④ WITH GST

Follow the procedure "WITH CONSULT-III".

⊗ WITHOUT CONSULT-III

1. Start engine.
2. Drive vehicle in D1 → D2 position.
3. Perform self-diagnosis. Refer to [AT-82, "Diagnosis Procedure without CONSULT-III"](#).
4. If the check result is NG, go to [AT-140, "Diagnosis Procedure"](#).

P0750 SHIFT SOLENOID A

< SERVICE INFORMATION >

Wiring Diagram - AT - SSV/A

INFOID:000000005928191

AT-SSV/A-01

: DETECTABLE LINE FOR DTC
 : NON-DETECTABLE LINE FOR DTC

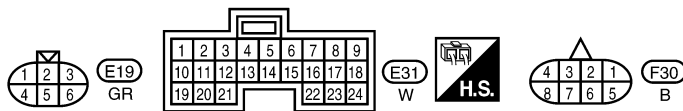
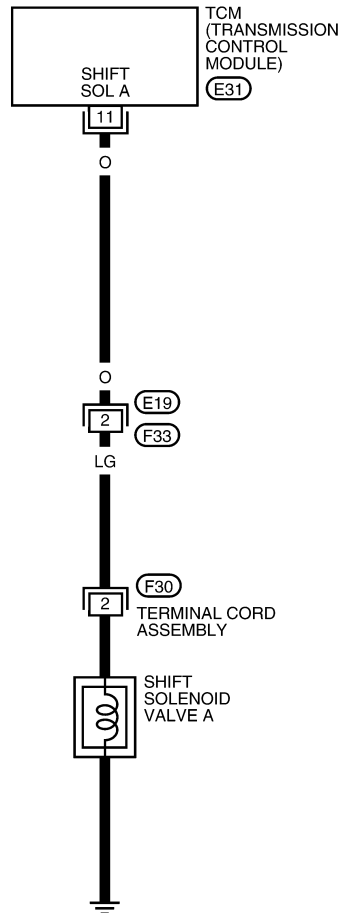

TCM TERMINALS AND REFERENCE VALUES

Refer to [AT-75, "TCM Terminal and Reference Value"](#).

BCWA0655E

P0750 SHIFT SOLENOID A

< SERVICE INFORMATION >

Diagnosis Procedure

INFOID:000000005928192

1. CHECK INPUT SIGNAL

With CONSULT-III

1. Start engine.
2. Select "MAIN SIGNALS" in "DATA MONITOR" mode for "TRANSMISSION" with CONSULT-III.
3. Read out the value of "SHIFT S/V A" while driving.
Check the value changes according to driving speed.

Item name	Condition	Display value
SHIFT S/V A	When shift solenoid valve A operates. (When driving in "D1" or "D4".)	ON
	When shift solenoid valve A does not operate. (When driving in "D2" or "D3".)	OFF

Without CONSULT-III

1. Start engine.
2. Check voltage between TCM connector terminal and ground.

Item	Connector	Terminal	Condition	Judgment standard (Approx.)
Shift solenoid valve A	E31	11 - Ground	When shift solenoid valve A operates. (When driving in "D1" or "D4".)	Battery voltage
			When shift solenoid valve A does not operate. (When driving in "D2" or "D3".)	0 V

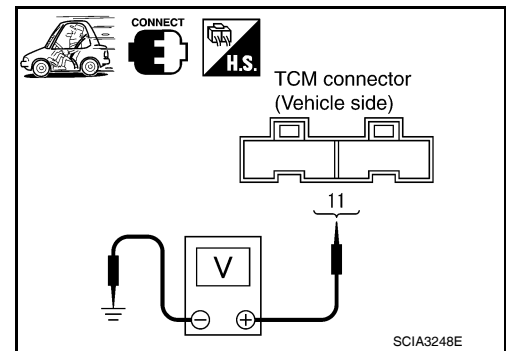

OK or NG

- OK >> GO TO 5.
NG >> GO TO 2.

2. CHECK SHIFT SOLENOID VALVE A CIRCUIT

1. Turn ignition switch OFF.
2. Disconnect TCM connector.
3. Check resistance between TCM connector terminal and ground.

Solenoid Valve	Connector	Terminal	Resistance (Approx.)
Shift solenoid valve A	E31	11 - Ground	20 - 30 Ω

OK or NG

- OK >> GO TO 5.
NG >> GO TO 3.

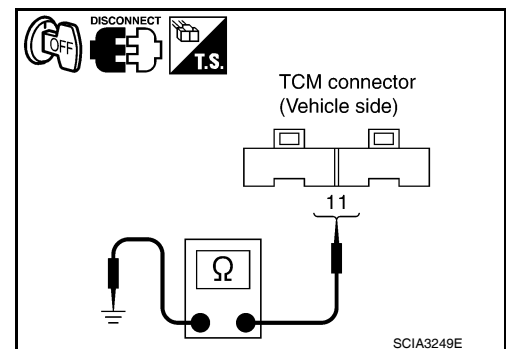

3. CHECK HARNESS BETWEEN TCM AND TERMINAL CORD ASSEMBLY HARNESS CONNECTOR

1. Turn ignition switch OFF.
2. Disconnect terminal cord assembly harness connector and TCM connector.

P0750 SHIFT SOLENOID A

< SERVICE INFORMATION >

- Check continuity between terminal cord assembly harness connector terminal and TCM connector terminal.

Item	Connector	Terminal	Continuity
TCM	E31	11	Yes
Terminal cord assembly harness connector	F30	2	

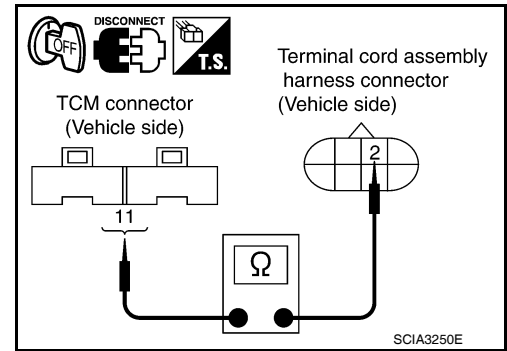

- If OK, check harness for short to ground and short to power.
- If OK, check continuity between ground and transaxle assembly.
- Reinstall any part removed.

OK or NG

- OK >> GO TO 4.
- NG >> Repair open circuit or short to ground or short to power in harness or connectors.

4. CHECK VALVE RESISTANCE

- Turn ignition switch OFF.
- Disconnect terminal cord assembly connector in engine room.
- Check resistance between terminal cord assembly harness connector terminal and ground.

Solenoid valve	Connector	Terminal	Resistance (Approx.)
Shift solenoid valve A	F30	2 - Ground	20 - 30 Ω

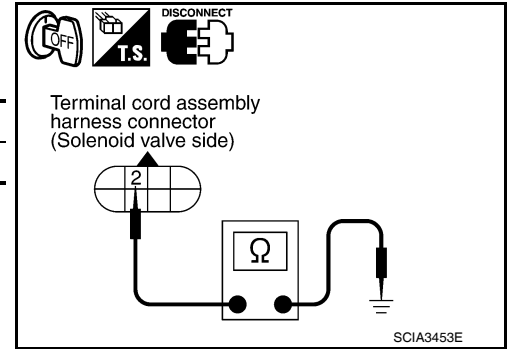

OK or NG

- OK >> GO TO 5.
- NG >> Repair or replace damaged parts.

5. CHECK DTC

Perform [AT-138, "DTC Confirmation Procedure"](#).

OK or NG

- OK >> **INSPECTION END**
- NG >> GO TO 6.

6. CHECK TCM

- Check TCM input/output signal. Refer to [AT-75, "TCM Terminal and Reference Value"](#).
- If NG, recheck TCM pin terminals for damage or loose connection with harness connector.

OK or NG

- OK >> **INSPECTION END**
- NG >> Repair or replace damaged parts.

Component Inspection

INFOID:000000005928193

SHIFT SOLENOID VALVE A

- For removal, refer to [AT-222, "Control Valve Assembly and Accumulators"](#).

Resistance Check

P0750 SHIFT SOLENOID A

< SERVICE INFORMATION >

- Check resistance between terminal and ground.

Solenoid valve	Connector	Terminal	Resistance (Approx.)
Shift solenoid valve A	F30	2 - Ground	20 - 30 Ω

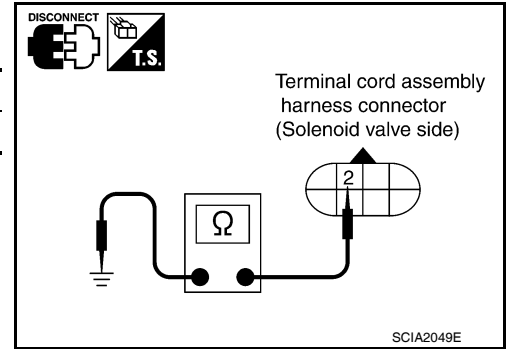

Operation Check

- Check solenoid valve by listening for its operating sound while applying battery voltage to the terminal and ground.

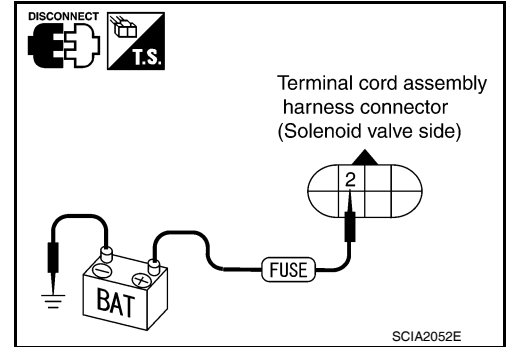

P0755 SHIFT SOLENOID B

< SERVICE INFORMATION >

P0755 SHIFT SOLENOID B

Description

INFOID:000000005928194

Shift solenoid valves A and B are turned ON or OFF by the TCM in response to signals sent from the transmission range switch, vehicle speed and ECM (throttle opening). Gears will then be shifted to the optimum position.

Gear position	1	2	3	4
Shift solenoid valve A	ON (Closed)	OFF (Open)	OFF (Open)	ON (Closed)
Shift solenoid valve B	ON (Closed)	ON (Closed)	OFF (Open)	OFF (Open)

CONSULT-III Reference Value in Data Monitor Mode

INFOID:000000005928195

Item name	Condition	Display value
SHIFT S/V B	When shift solenoid valve B operates. (When driving in "D1" or "D2".)	ON
	When shift solenoid valve B does not operate. (When driving in "D3" or "D4".)	OFF

On Board Diagnosis Logic

INFOID:000000005928196

- This is an OBD-II self-diagnostic item.
- Diagnostic trouble code "P0755 SHIFT SOLENOID B" with CONSULT-III or 5th judgement flicker without CONSULT-III is detected when TCM detects an improper voltage drop when it tries to operate the solenoid valve.

Possible Cause

INFOID:000000005928197

- Harness or connector
(The solenoid circuit is open or shorted.)
- Shift solenoid valve B

DTC Confirmation Procedure

INFOID:000000005928198

CAUTION:

- **Always drive vehicle at a safe speed.**
- **If performing this "DTC Confirmation Procedure" again, always turn ignition switch OFF and wait at least 10 seconds before continuing.**

After the repair, perform the following procedure to confirm the malfunction is eliminated.

④ WITH CONSULT-III

1. Turn ignition switch ON and select "DATA MONITOR" mode for "TRANSMISSION" with CONSULT-III.
2. Touch "START".
3. Start engine.
4. Drive vehicle in D position and allow the transaxle to shift 1 → 2 → 3 ("GEAR").
5. If the check result is NG, go to [AT-145, "Diagnosis Procedure"](#).

④ WITH GST

Follow the procedure "WITH CONSULT-III".

⊗ WITHOUT CONSULT-III

1. Start engine.
2. Drive vehicle in D1 → D2 → D3 position.
3. Perform self-diagnosis. Refer to [AT-82, "Diagnosis Procedure without CONSULT-III"](#).
4. If the check result is NG, go to [AT-145, "Diagnosis Procedure"](#).

P0755 SHIFT SOLENOID B

< SERVICE INFORMATION >

Wiring Diagram - AT - SSV/B

INFOID:000000005928199

AT-SSV/B-01

: DETECTABLE LINE FOR DTC
 : NON-DETECTABLE LINE FOR DTC

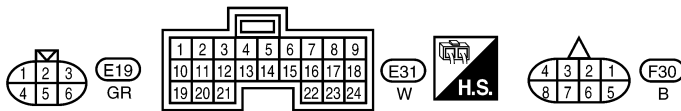
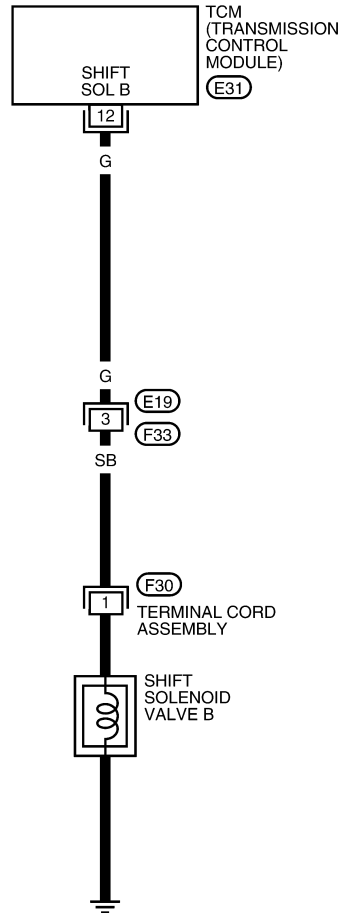

BCWA0656E

TCM TERMINALS AND REFERENCE VALUES

Refer to [AT-75, "TCM Terminal and Reference Value"](#).

P0755 SHIFT SOLENOID B

< SERVICE INFORMATION >

Diagnosis Procedure

INFOID:000000005928200

1. CHECK INPUT SIGNAL

With CONSULT-III

1. Start engine.
2. Select "MAIN SIGNALS" in "DATA MONITOR" mode for "TRANSMISSION" with CONSULT-III.
3. Read out the value of "SHIFT S/V B" while driving.
Check the value changes according to driving speed.

Item name	Condition	Display value
SHIFT S/V B	When shift solenoid valve B operates. (When driving in "D1" or "D2".)	ON
	When shift solenoid valve B does not operate. (When driving in "D3" or "D4".)	OFF

Without CONSULT-III

1. Start engine.
2. Check voltage between TCM connector terminal and ground.

Item	Connector	Terminal	Condition	Judgment standard (Approx.)
Shift solenoid valve B	E31	12 - Ground	When shift solenoid valve B operates. (When driving in "D1" or "D2".)	Battery voltage
			When shift solenoid valve B does not operate. (When driving in "D3" or "D4".)	0 V

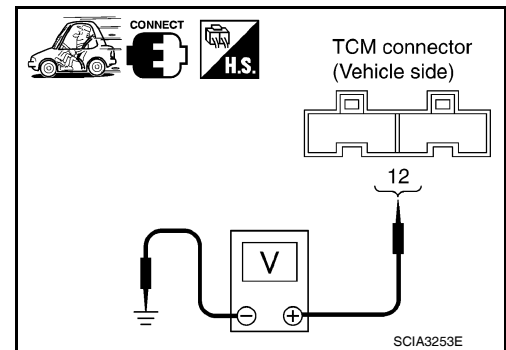

OK or NG

- OK >> GO TO 5.
NG >> GO TO 2.

2. CHECK SHIFT SOLENOID VALVE B CIRCUIT

1. Turn ignition switch OFF.
2. Disconnect TCM connector.
3. Check resistance between TCM connector terminal and ground.

Solenoid Valve	Connector	Terminal	Resistance (Approx.)
Shift solenoid valve B	E31	12 - Ground	5 - 20 Ω

OK or NG

- OK >> GO TO 5.
NG >> GO TO 3.

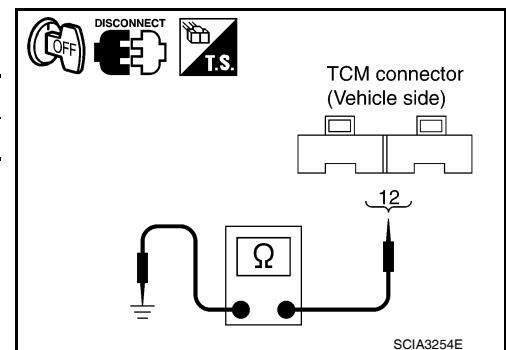

3. CHECK HARNESS BETWEEN TCM AND TERMINAL CORD ASSEMBLY HARNESS CONNECTOR

1. Turn ignition switch OFF.
2. Disconnect terminal cord assembly harness connector and TCM connector.

P0755 SHIFT SOLENOID B

< SERVICE INFORMATION >

3. Check continuity between terminal cord assembly harness connector terminal and TCM connector terminal.

Item	Connector	Terminal	Continuity
TCM	E31	12	Yes
Terminal cord assembly harness connector	F30	1	

4. If OK, check harness for short to ground and short to power.
5. If OK, check continuity between ground and transaxle assembly.
6. Reinstall any part removed.

OK or NG

OK >> GO TO 4.

NG >> Repair open circuit or short to ground or short to power in harness or connectors.

4. CHECK VALVE RESISTANCE

1. Turn ignition switch OFF.
2. Disconnect terminal cord assembly connector in engine room.
3. Check resistance between terminal cord assembly harness connector terminal and ground.

Solenoid valve	Connector	Terminal	Resistance (Approx.)
Shift solenoid valve B	F30	1 - Ground	5 - 20 Ω

OK or NG

OK >> GO TO 5.

NG >> Repair or replace damaged parts.

5. CHECK DTC

Perform [AT-143, "DTC Confirmation Procedure"](#) .

OK or NG

OK >> **INSPECTION END**

NG >> GO TO 6.

6. CHECK TCM

1. Check TCM input/output signal. Refer to [AT-75, "TCM Terminal and Reference Value"](#) .
2. If NG, recheck TCM pin terminals for damage or loose connection with harness connector.

OK or NG

OK >> **INSPECTION END**

NG >> Repair or replace damaged parts.

Component Inspection

INFOID:000000005928201

SHIFT SOLENOID VALVE B

- For removal, refer to [AT-222, "Control Valve Assembly and Accumulators"](#) .

Resistance Check

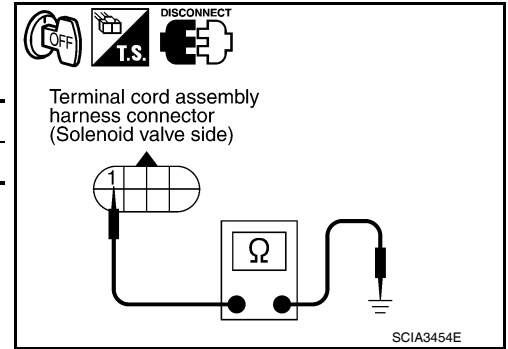
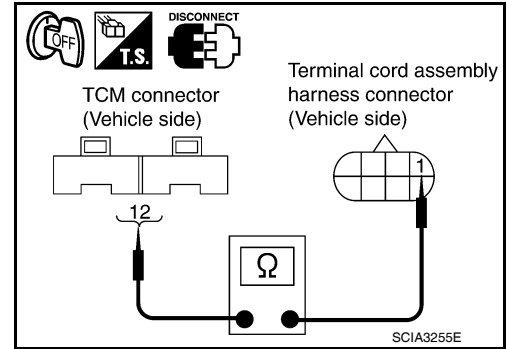

P0755 SHIFT SOLENOID B

< SERVICE INFORMATION >

- Check resistance between terminal and ground.

Solenoid valve	Connector	Terminal	Resistance (Approx.)
Shift solenoid valve B	F30	1 - Ground	5 - 20 Ω

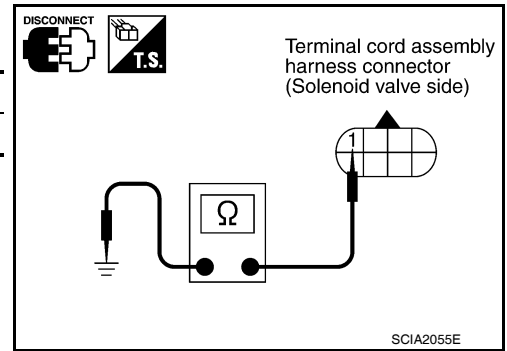

Operation Check

- Check solenoid valve by listening for its operating sound while applying battery voltage to the terminal and ground.

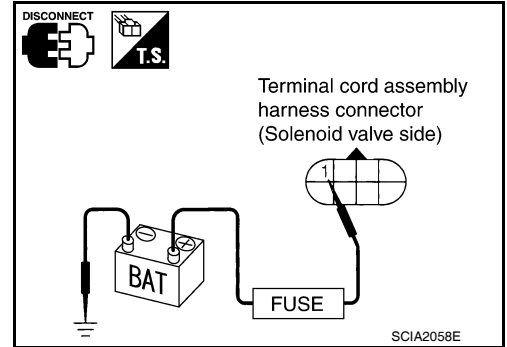

A
B
AT
D
E
F
G
H
I
J
K
L
M
N
O
P

P1760 OVERRUN CLUTCH SOLENOID

< SERVICE INFORMATION >

P1760 OVERRUN CLUTCH SOLENOID

Description

INFOID:000000005928202

The overrun clutch solenoid valve is activated by the TCM in response to signals sent from the transmission range switch, overdrive control switch, vehicle speed and ECM (throttle opening). The overrun clutch operation will then be controlled.

CONSULT-III Reference Value in Data Monitor Mode

INFOID:000000005928203

Item name	Condition	Display value
OVERRUN/C S/V	When overrun clutch solenoid valve operates. (When overrun clutch disengaged. Refer to AT-22 .)	ON
	When overrun clutch solenoid valve does not operate. (When overrun clutch engaged. Refer to AT-22 .)	OFF

On Board Diagnosis Logic

INFOID:000000005928204

- This is an OBD-II self-diagnostic item.
- Diagnostic trouble code "P1760 OVER CLUTCH SOLENOID" with CONSULT-III or 6th judgement flicker without CONSULT-III is detected when TCM detects an improper voltage drop when it tries to operate solenoid valve.

Possible Cause

INFOID:000000005928205

- Harness or connector
(The solenoid circuit is open or shorted.)
- Overrun clutch solenoid valve

DTC Confirmation Procedure

INFOID:000000005928206

CAUTION:

- **Always drive vehicle at a safe speed.**
- **If performing this "DTC Confirmation Procedure" again, always turn ignition switch OFF and wait at least 10 seconds before continuing.**

After the repair, perform the following procedure to confirm the malfunction is eliminated.

WITH CONSULT-III

1. Turn ignition switch ON and select "DATA MONITOR" mode for "TRANSMISSION" with CONSULT-III.
2. Touch "START".
3. Start engine.
4. Accelerate vehicle to a speed of more than 10 km/h (6 MPH) with "D" position (OD ON).
5. Release accelerator pedal completely with "D" position (OD OFF).
6. If the check result is NG, go to [AT-150, "Diagnosis Procedure"](#).

WITH GST

Follow the procedure "WITH CONSULT-III".

WITHOUT CONSULT-III

1. Start engine.
2. Drive vehicle under the following conditions:
Selector lever position: "D" position (OD ON)
Vehicle speed: Higher than 10 km/h (6 MPH)
3. Perform self-diagnosis. Refer to [AT-82, "Diagnosis Procedure without CONSULT-III"](#) .
4. If the check result is NG, go to [AT-150, "Diagnosis Procedure"](#) .

P1760 OVERRUN CLUTCH SOLENOID

< SERVICE INFORMATION >

Wiring Diagram - AT - OVRCSV

INFOID:000000005928207

AT-OVRCSV-01

: DETECTABLE LINE FOR DTC
 : NON-DETECTABLE LINE FOR DTC

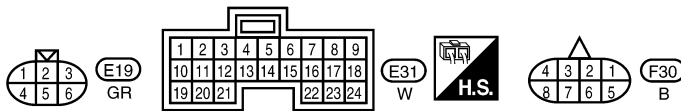
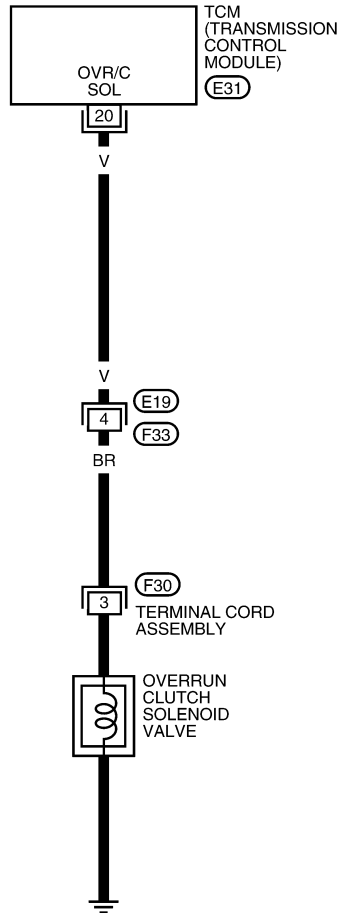

TCM TERMINALS AND REFERENCE VALUES

Refer to [AT-75, "TCM Terminal and Reference Value"](#).

BCWA0657E

P1760 OVERRUN CLUTCH SOLENOID

< SERVICE INFORMATION >

Diagnosis Procedure

INFOID:000000005928208

1. CHECK INPUT SIGNAL

With CONSULT-III

1. Start engine.
2. Select "MAIN SIGNALS" in "DATA MONITOR" mode for "TRANSMISSION" with CONSULT-III.
3. Read out the value of "OVERRUN/C S/V" while driving.
Check the value changes according to driving speed.

Item name	Condition	Display value
OVERRUN/C S/V	When overrun clutch solenoid valve operates. (When overrun clutch disengaged. Refer to AT-22 .)	ON
	When overrun clutch solenoid valve does not operate. (When overrun clutch engaged. Refer to AT-22 .)	OFF

Without CONSULT-III

1. Start engine.
2. Check voltage between TCM connector terminal and ground.

Item	Connector	Terminal	Condition	Judgment standard (Approx.)
Overrun clutch solenoid valve	E31	20 - Ground	When overrun clutch solenoid valve operates. (When overrun clutch disengaged. Refer to AT-22 .)	Battery voltage
			When overrun clutch solenoid valve does not operate. (When overrun clutch engaged. Refer to AT-22 .)	0 V

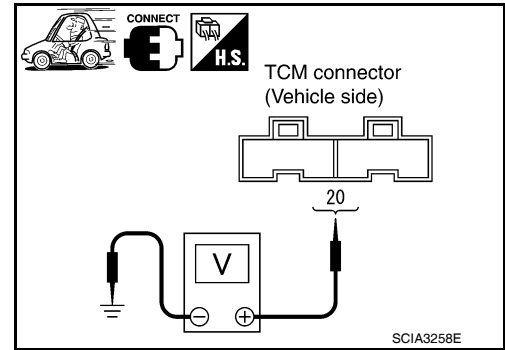

OK or NG

- OK >> GO TO 5.
NG >> GO TO 2.

2. CHECK OVERRUN CLUTCH SOLENOID VALVE CIRCUIT

1. Turn ignition switch OFF.
2. Disconnect TCM connector.
3. Check resistance between TCM connector terminal and ground.

Solenoid Valve	Connector	Terminal	Resistance (Approx.)
Overrun clutch solenoid valve	E31	20 - Ground	20 - 30 Ω

OK or NG

- OK >> GO TO 5.
NG >> GO TO 3.

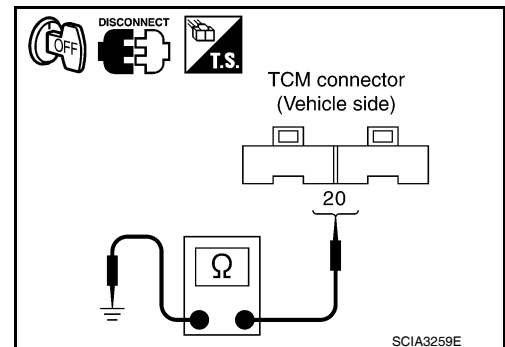

3. CHECK HARNESS BETWEEN TCM AND TERMINAL CORD ASSEMBLY HARNESS CONNECTOR

1. Turn ignition switch OFF.
2. Disconnect terminal cord assembly harness connector and TCM connector.

P1760 OVERRUN CLUTCH SOLENOID

< SERVICE INFORMATION >

3. Check continuity between terminal cord assembly harness connector terminal and TCM connector terminal.

Item	Connector	Terminal	Continuity
TCM	E31	20	Yes
Terminal cord assembly harness connector	F30	3	

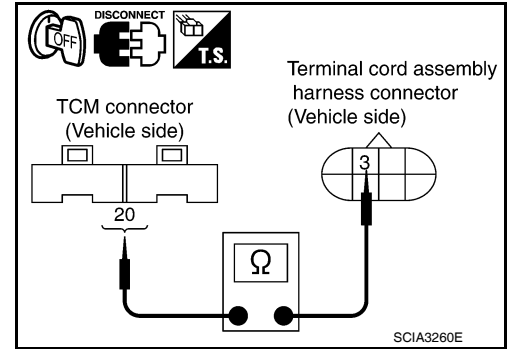

4. If OK, check harness for short to ground and short to power.
5. If OK, check continuity between ground and transaxle assembly.
6. Reinstall any part removed.

OK or NG

- OK >> GO TO 4.
- NG >> Repair open circuit or short to ground or short to power in harness or connectors.

4. CHECK VALVE RESISTANCE

1. Turn ignition switch OFF.
2. Disconnect terminal cord assembly connector in engine room.
3. Check resistance between terminal cord assembly harness connector terminal and ground.

Solenoid valve	Connector	Terminal	Resistance (Approx.)
Overrun clutch solenoid valve	F30	3 - Ground	20 - 30 Ω

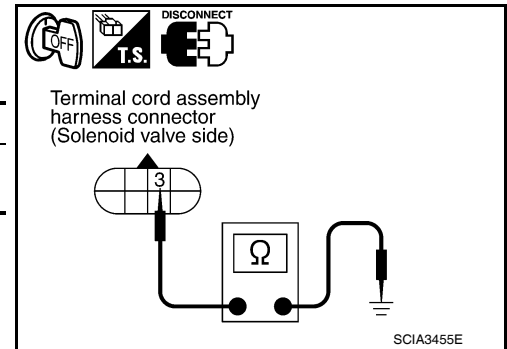

OK or NG

- OK >> GO TO 5.
- NG >> Repair or replace damaged parts.

5. CHECK DTC

Perform [AT-148, "DTC Confirmation Procedure"](#).

OK or NG

- OK >> **INSPECTION END**
- NG >> GO TO 6.

6. CHECK TCM

1. Check TCM input/output signal. Refer to [AT-75, "TCM Terminal and Reference Value"](#).
2. If NG, recheck TCM pin terminals for damage or loose connection with harness connector.

OK or NG

- OK >> **INSPECTION END**
- NG >> Repair or replace damaged parts.

Component Inspection

INFOID:000000005928209

OVERRUN CLUTCH SOLENOID VALVE

- For removal, refer to [AT-222, "Control Valve Assembly and Accumulators"](#).

Resistance Check

P1760 OVERRUN CLUTCH SOLENOID

< SERVICE INFORMATION >

- Check resistance between terminal and ground.

Solenoid valve	Connector	Terminal	Resistance (Approx.)
Overrun clutch solenoid valve	F30	3 - Ground	20 - 30 Ω

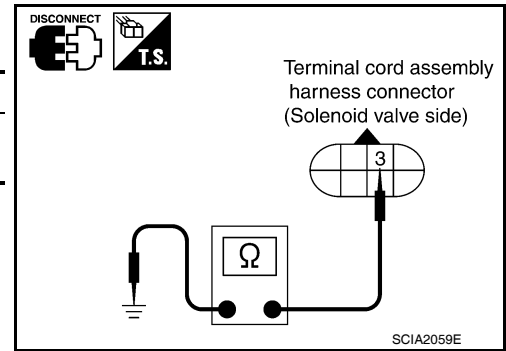

Operation Check

- Check solenoid valve by listening for its operating sound while applying battery voltage to the terminal and ground.

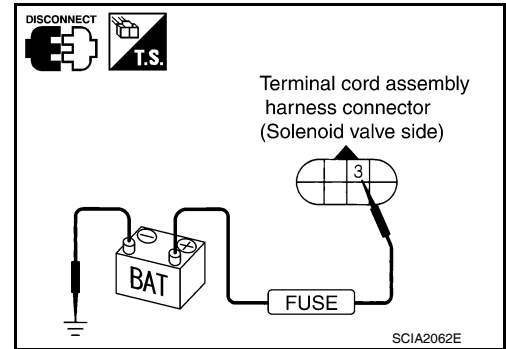

VEHICLE SPEED SIGNAL

< SERVICE INFORMATION >

VEHICLE SPEED SIGNAL

Description

INFOID:000000005928210

The vehicle speed signal is built into the speedometer assembly. The sensor functions as an auxiliary device to the output speed sensor when it is malfunctioning. The TCM will then use a signal sent from the vehicle speed signal.

CONSULT-III Reference Value in Data Monitor Mode

INFOID:000000005928211

Remarks: Specification data are reference values.

Item name	Condition	Display value
VHCL/S SE-MTR	During driving	Approximately matches the speedometer reading.

On Board Diagnosis Logic

INFOID:000000005928212

- This is not an OBD-II self-diagnostic item.
- Diagnostic trouble code "VEHECLE SPEED SIGNAL" with CONSULT-III or 2nd judgement flicker without CONSULT-III is detected when TCM does not receive the proper voltage signal from the sensor.

Possible Cause

INFOID:000000005928213

- Harness or connector
(The sensor circuit is open or shorted.)
- Vehicle speed signal

DTC Confirmation Procedure

INFOID:000000005928214

CAUTION:

- **Always drive vehicle at a safe speed.**
- **If performing this "DTC Confirmation Procedure" again, always turn ignition switch OFF and wait at least 10 seconds before continuing.**

After the repair, perform the following procedure to confirm the malfunction is eliminated.

Ⓟ WITH CONSULT-III

1. Turn ignition switch ON and select "DATA MONITOR" mode for "TRANSMISSION" with CONSULT-III.
2. Touch "START".
3. Start engine and accelerate vehicle from 0 to 25 km/h (0 to 16 MPH).
4. If the check result is NG, go to [AT-155. "Diagnosis Procedure"](#).

ⓧ WITHOUT CONSULT-III

1. Start engine.
2. Drive vehicle under the following conditions:
Selector lever position: "D" position
Vehicle speed: Higher than 25 km/h (16 MPH)
3. Perform self-diagnosis. Refer to [AT-82. "Diagnosis Procedure without CONSULT-III"](#).
4. If the check result is NG, go to [AT-155. "Diagnosis Procedure"](#).



VEHICLE SPEED SIGNAL

< SERVICE INFORMATION >

Wiring Diagram - AT - VSSMTR

INFOID:000000005928215

AT-VSSMTR-01

 : DETECTABLE LINE FOR DTC
 : NON-DETECTABLE LINE FOR DTC

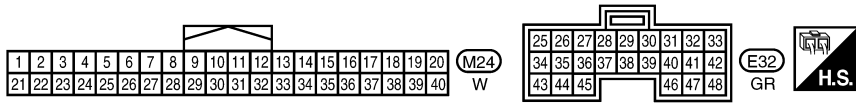
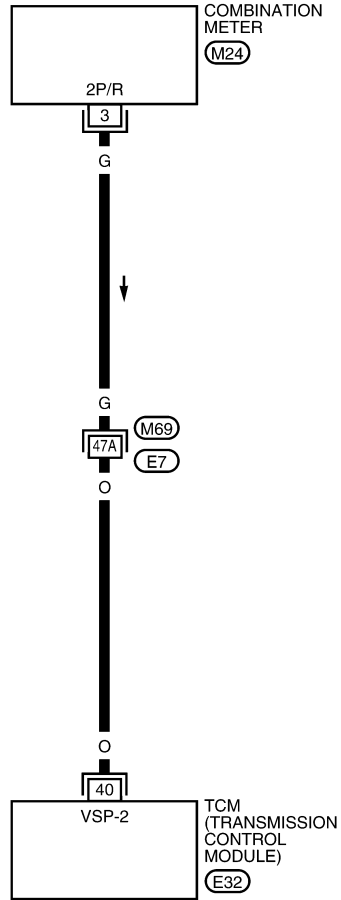

REFER TO THE FOLLOWING.
 (M69) - SUPER MULTIPLE JUNCTION (SMJ)

BCWA0658E

TCM TERMINALS AND REFERENCE VALUES

Refer to [AT-75, "TCM Terminal and Reference Value"](#).

VEHICLE SPEED SIGNAL

< SERVICE INFORMATION >

Diagnosis Procedure

INFOID:000000005928216

1. CHECK INPUT SIGNAL

With CONSULT-III

1. Start engine.
2. Select "TCM INPUT SIGNALS" in "DATA MONITOR" mode for "TRANSMISSION" with CONSULT-III.
3. Read out the value of "VHCL/S SE-MTR" while driving. Check the value changes according to driving speed.

Item name	Condition	Display value
VHCL/S SE-MTR	During driving	Approximately matches the speedometer reading.

Without CONSULT-III

1. Start engine.
2. Check voltage between TCM connector terminal and ground.

Item	Connector	Terminal	Condition	Judgement standard (Approx.)
Vehicle speed signal	E32	40 - Ground	When driving vehicle at 2 to 3 km/h (1 to 2 MPH) for 1 m (3 ft) or more.	Voltage varies between less than 0 V and more than 4.5 V

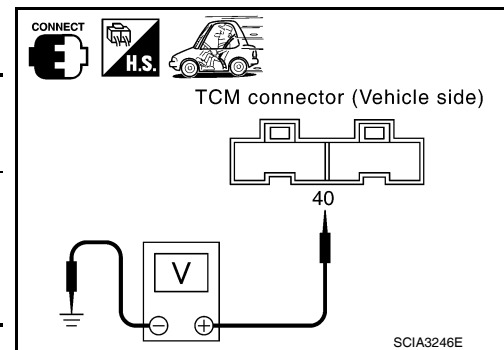

OK or NG

- OK >> GO TO 3.
 NG >> GO TO 2.

2. DETECT MALFUNCTIONING ITEM

Check the following items:

- Combination meter. Refer to [DI-4](#).
- Harness for short or open between TCM and combination meter.

OK or NG

- OK >> GO TO 3.
 NG >> Repair or replace damaged parts.

3. CHECK DTC

Perform [AT-153, "DTC Confirmation Procedure"](#).

OK or NG

- OK >> **INSPECTION END**
 NG >> GO TO 4.

4. CHECK TCM

1. Check TCM input/output signal. Refer to [AT-75, "TCM Terminal and Reference Value"](#).
2. If NG, recheck TCM pin terminals for damage or loose connection with harness connector.

OK or NG

- OK >> **INSPECTION END**
 NG >> Repair or replace damaged parts.

BATT/FLUID TEMP SEN

< SERVICE INFORMATION >

BATT/FLUID TEMP SEN

Description

INFOID:000000005928217

The A/T fluid temperature sensor detects the A/T fluid temperature and sends a signal to the TCM.

CONSULT-III Reference Value in Data Monitor Mode

INFOID:000000005928218

Remarks: Specification data are reference values.

Item name	Condition	Display value
FLUID TEMP SE	When A/T fluid temperature is 20°C (68°F).	1.5 V
	When A/T fluid temperature is 80°C (176°F).	0.5 V

On Board Diagnosis Logic

INFOID:000000005928219

- This is not an OBD-II self-diagnostic item.
- Diagnostic trouble code "BATT/FLUID TEMP SEN" with CONSULT-III or 8th judgement flicker without CONSULT-III is detected when TCM receives an excessively low or high voltage from the sensor.

Possible Cause

INFOID:000000005928220

- Harness or connector
(The sensor circuit is open or shorted.)
- A/T fluid temperature sensor

DTC Confirmation Procedure

INFOID:000000005928221

CAUTION:

- **Always drive vehicle at a safe speed.**
- **If performing this "DTC Confirmation Procedure" again, always turn ignition switch OFF and wait at least 10 seconds before continuing.**

After the repair, perform the following procedure to confirm the malfunction is eliminated.

④ WITH CONSULT-III

1. Start engine.
2. Select "DATA MONITOR" mode for "TRANSMISSION" with CONSULT-III.
3. Touch "START".
4. Drive vehicle under the following conditions.
SLCT LVR POSI: "D" position
VEHICLE SPEED: Higher than 20 km/h (12 MPH)
5. If the check result is NG, go to [AT-158, "Diagnosis Procedure"](#).

⊗ WITHOUT CONSULT-III

1. Start engine.
2. Drive vehicle under the following conditions.
Selector lever position: D position
Vehicle speed: higher than 20 km/h (12 MPH)
3. Perform self-diagnosis. Refer to [AT-82, "Diagnosis Procedure without CONSULT-III"](#).
4. If the check result is NG, go to [AT-158, "Diagnosis Procedure"](#).

BATT/FLUID TEMP SEN

< SERVICE INFORMATION >

Wiring Diagram - AT - BA/FTS

INFOID:000000005928222

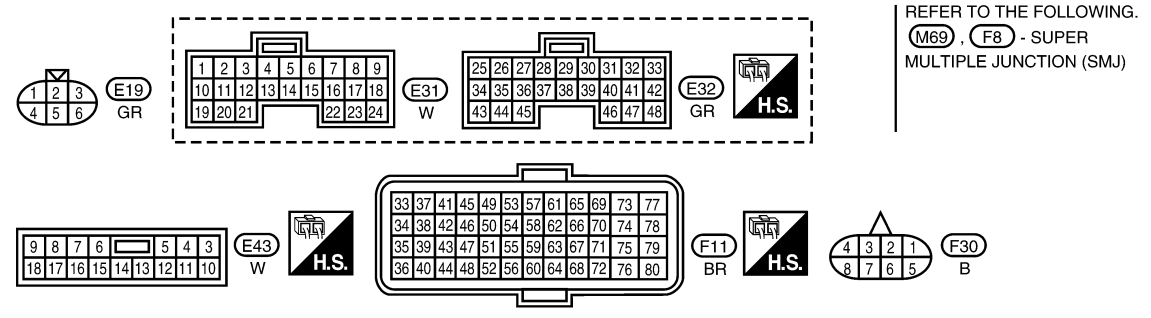
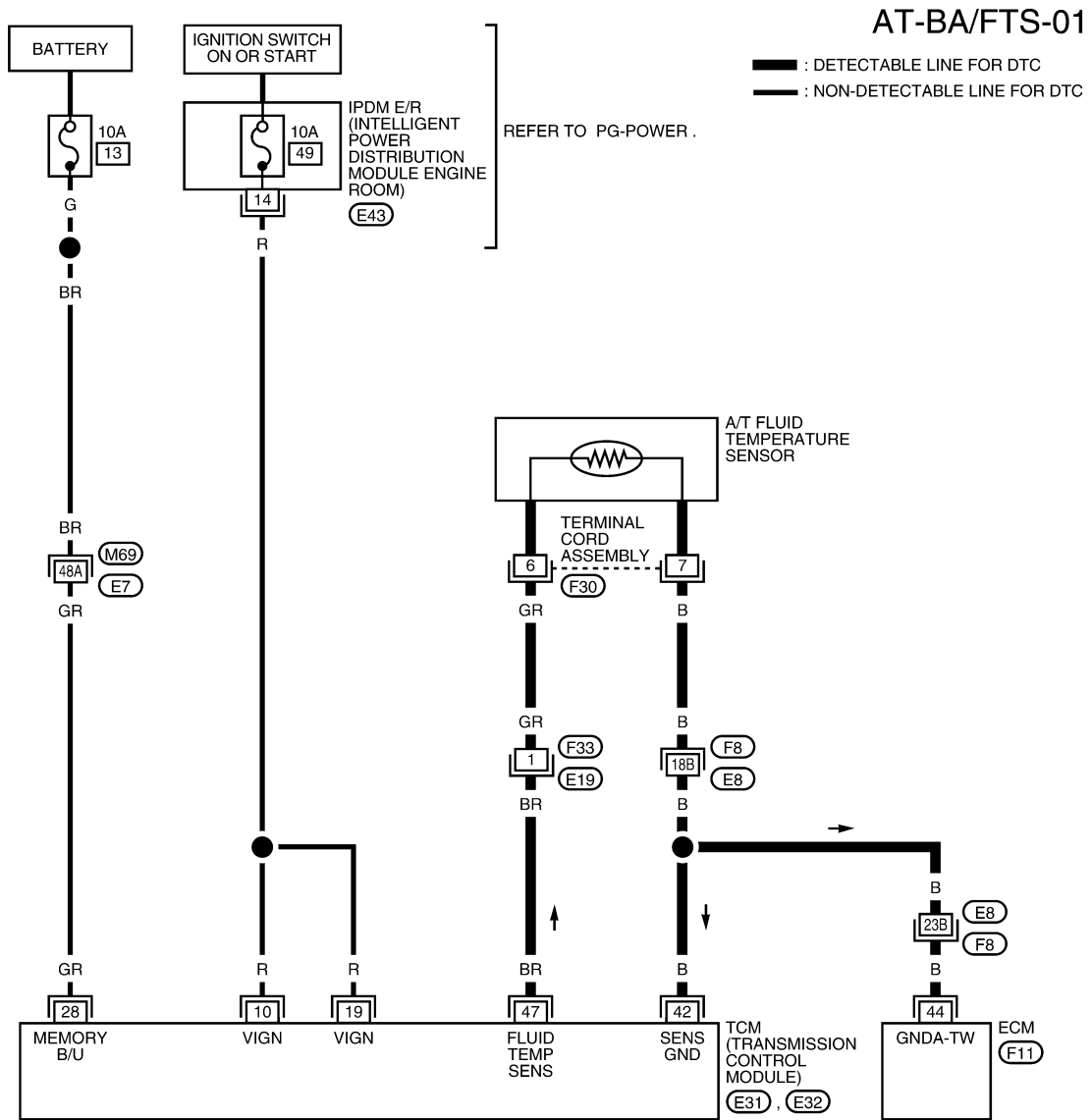

TCM TERMINALS AND REFERENCE VALUES
 Refer to [AT-75, "TCM Terminal and Reference Value"](#).

BCWA0659E

BATT/FLUID TEMP SEN

< SERVICE INFORMATION >

Diagnosis Procedure

INFOID:000000005928223

1. CHECK TCM POWER SOURCE

1. Turn ignition switch ON. (Do not start engine.)
2. Check voltage between TCM connector terminals and ground.

Item	Connector	Terminal	Judgement standard (Approx.)
Power supply	E31	10	Battery voltage
		19	Battery voltage
Power supply (memory back-up)	E32	28	Battery voltage

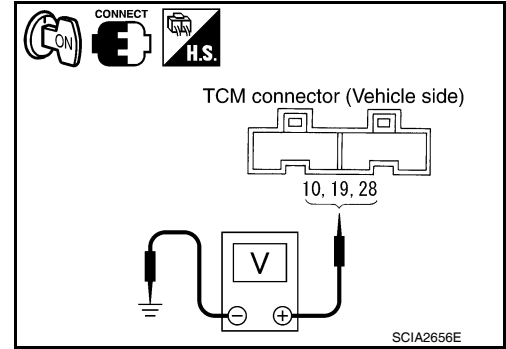

3. Turn ignition switch OFF.
4. Check voltage between TCM connector terminals and ground.

Item	Connector	Terminal	Judgement standard (Approx.)
Power supply	E31	10	0 V
		19	0 V
Power supply (memory back-up)	E32	28	Battery voltage

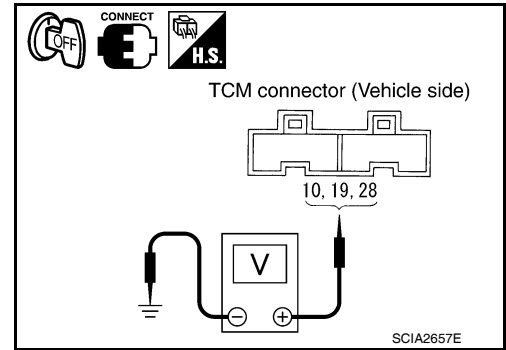

OK or NG

- OK >> GO TO 3.
 NG >> GO TO 2.

2. DETECT MALFUNCTIONING ITEM

Check the following items:

- Harness for short or open between ignition switch and TCM terminals 10, 19
- Harness for short or open between battery and TCM terminal 28
- 10A fuse (No.13, located in the fuse block) and 10A fuse (No.49, located in the IPDM E/R)
- Ignition switch. Refer to [PG-4](#).

OK or NG

- OK >> GO TO 9.
 NG >> Repair or replace damaged parts.

3. CHECK INPUT SIGNAL OF A/T FLUID TEMPERATURE SENSOR

With CONSULT-III

1. Start engine.
2. Select "TCM INPUT SIGNALS" in "DATA MONITOR" mode for "TRANSMISSION" with CONSULT-III.
3. Read out the value of "FLUID TEMP SE".

Item name	Condition	Display value
FLUID TEMP SE	When A/T fluid temperature is 20°C (68°F).	1.5 V
	When A/T fluid temperature is 80°C (176°F).	0.5 V

Without CONSULT-III

1. Start engine.

BATT/FLUID TEMP SEN

< SERVICE INFORMATION >

2. Check voltage TCM connector terminals while warming up A/T.

Item	Connector	Terminal	Condition	Judgement standard (Approx.)
A/T fluid temperature sensor	E32	47 - 42	When A/T fluid temperature is 20°C (68°F).	1.5 V
			When A/T fluid temperature is 80°C (176°F).	0.5 V

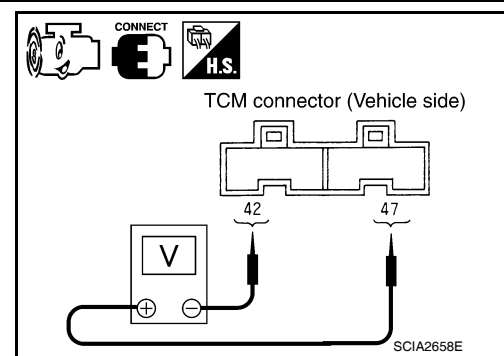

OK or NG

- OK >> GO TO 9.
- NG >> GO TO 4.

4. DETECT MALFUNCTIONING ITEM

Check the following items:

- Harness for short or open between TCM, ECM and terminal cord assembly
 - Ground circuit for ECM
- Refer to [EC-123. "Wiring Diagram"](#) (HR16DE), [EC-633. "Wiring Diagram"](#) (MR18DE).

OK or NG

- OK >> GO TO 5.
- NG >> Repair or replace damaged parts.

5. CHECK FLUID TEMPERATURE SENSOR CIRCUIT

1. Turn ignition switch OFF.
2. Disconnect the TCM connector.
3. Check resistance between terminals.

Item	Connector	Terminal	Temperature °C (°F)	Resistance (Approx.)
A/T fluid temperature sensor	E32	47 - 42	AT-380. "A/T Fluid Temperature Sensor"	

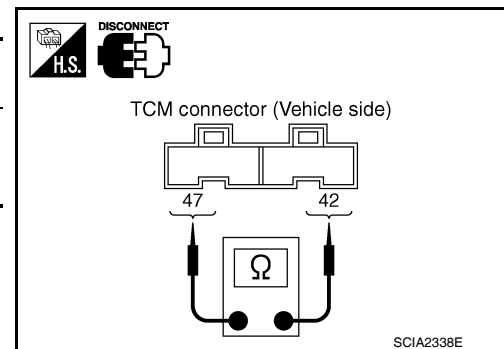

OK or NG

- OK >> GO TO 9.
- NG >> GO TO 6.

6. CHECK HARNESS BETWEEN TCM AND TERMINAL CORD ASSEMBLY HARNESS CONNECTOR

1. Turn ignition switch OFF.
2. Disconnect terminal cord assembly harness connector and TCM connector.
3. Check continuity between terminal cord assembly harness connector terminal and TCM connector terminal.

Item	Connector	Terminal	Continuity
TCM	E32	42	Yes
Terminal cord assembly harness connector	F30	7	
TCM	E32	47	Yes
Terminal cord assembly harness connector	F30	6	

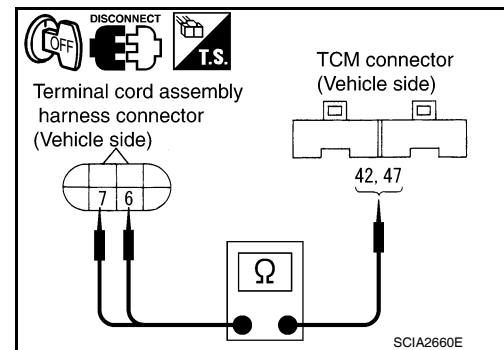

4. If OK, check harness for short to ground and short to power.
5. If OK, check continuity between ground and transaxle assembly.
6. Reinstall any part removed.

OK or NG

BATT/FLUID TEMP SEN

< SERVICE INFORMATION >

- OK >> GO TO 7.
 NG >> Repair open circuit or short to ground or short to power in harness or connectors.

7. CHECK A/T FLUID TEMPERATURE SENSOR WITH TERMINAL CORD ASSEMBLY

1. Turn ignition switch OFF.
2. Disconnect terminal cord assembly connector in engine room.
3. Check resistance between terminal cord assembly terminals.

Item	Connector	Terminal	Temperature [°C (°F)]	Resistance (Approx.)
A/T fluid temperature sensor	F30	6 - 7	AT-380, "A/T Fluid Temperature Sensor"	

4. Reinstall any part removed.

OK or NG

- OK >> GO TO 8.
 NG >> Repair or replace damaged parts.

8. DETECT MALFUNCTIONING ITEM

1. Remove oil pan. Refer to [AT-222, "Control Valve Assembly and Accumulators"](#) .
2. Check the following items:
 - A/T fluid temperature sensor
 - Check resistance between terminal cord assembly harness connector terminals while changing temperature as shown.

Item	Connector	Terminal	Temperature [°C (°F)]	Resistance (Approx.)
A/T fluid temperature sensor	F30	6 - 7	AT-380, "A/T Fluid Temperature Sensor"	

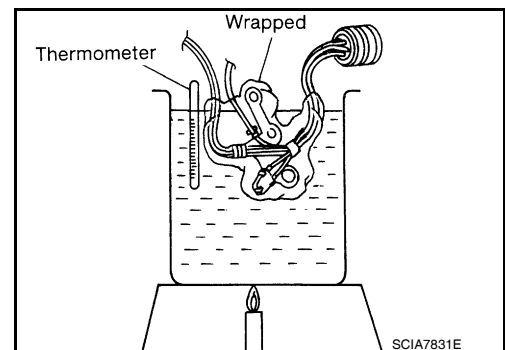
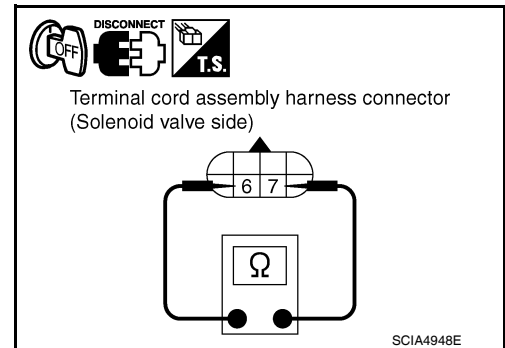

- Harness of terminal cord assembly for short or open

OK or NG

- OK >> GO TO 9.
 NG >> Repair or replace damaged parts.

9. CHECK DTC

Perform [AT-156, "DTC Confirmation Procedure"](#) .

OK or NG

- OK >> **INSPECTION END**
 NG >> GO TO 10.

10. CHECK TCM

1. Check TCM input/output signal. Refer to [AT-75, "TCM Terminal and Reference Value"](#) .
2. If NG, recheck TCM pin terminals for damage or loose connection with harness connector.

OK or NG

- OK >> **INSPECTION END**
 NG >> Repair or replace damaged parts.

Component Inspection

INFOID:000000005928224

A/T FLUID TEMPERATURE SENSOR

BATT/FLUID TEMP SEN

< SERVICE INFORMATION >

- Remove oil pan. Refer to [AT-222. "Control Valve Assembly and Accumulators"](#).
- Check resistance between terminal cord assembly harness connector terminals while changing temperature as shown.

Item	Connector	Terminal	Temperature [°C (°F)]	Resistance (Approx.)
A/T fluid temperature sensor	F30	6 - 7	AT-380. "A/T Fluid Temperature Sensor"	

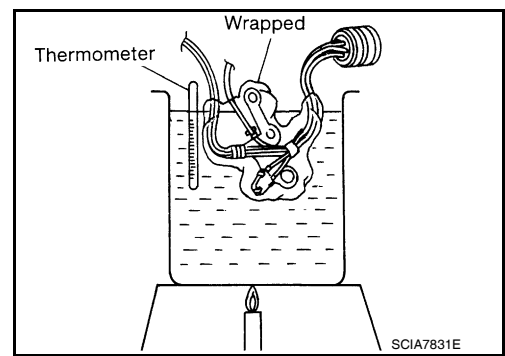

A
B
AT
D
E
F
G
H
I
J
K
L
M
N
O
P

INPUT SPEED SENSOR A

< SERVICE INFORMATION >

INPUT SPEED SENSOR A

Description

INFOID:000000005928225

The input speed sensor detects forward clutch drum rpm (revolutions per minute). It is located on the input side of the automatic transaxle. The output speed sensor is located on the output side of the automatic transaxle. With the two sensors, input and output rpms are accurately detected. As a result, optimal shift timing during deceleration and shift quality can be improved.

CONSULT-III Reference Value in Data Monitor Mode

INFOID:000000005928226

Remarks: Specification data are reference values.

Item name	Condition	Display value
INPUT SPEED	During driving (lock-up ON)	Approximately matches the engine speed.

On Board Diagnosis Logic

INFOID:000000005928227

- This is not an OBD-II self-diagnostic item.
- Diagnostic trouble code "INPUT SPEED SENSOR A" with CONSULT-III or 10th judgement flicker without CONSULT-III is detected when TCM does not receive the proper voltage signal from the sensor.

Possible Cause

INFOID:000000005928228

- Harness or connector
(The sensor circuit is open or shorted.)
- Input speed sensor

DTC Confirmation Procedure

INFOID:000000005928229

CAUTION:

- **Always drive vehicle at a safe speed.**
- **Be careful not to rev engine into the red zone on the tachometer.**
- **If performing this "DTC Confirmation Procedure" again, always turn ignition switch OFF and wait at least 10 seconds before continuing.**

After the repair, perform the following procedure to confirm the malfunction is eliminated.

④ WITH CONSULT-III

1. Start engine.
2. Select "DATA MONITOR" mode for "TRANSMISSION" with CONSULT-III.
3. Touch "START".
4. Drive vehicle under the following conditions for more than 5 seconds.
SLCT LVR POSI: "D" position
VEHICLE SPEED: Higher than 40 km/h (25 MPH)
ENGINE SPEED: Higher than 1,500 rpm
THROTTLE POSI: Greater than 1.0/8 of the full throttle position
5. If the check result is NG, go to [AT-164, "Diagnosis Procedure"](#).

⊗ WITHOUT CONSULT-III

1. Start engine.
2. Drive vehicle under the following conditions for more than 5 seconds.
Selector lever position: "D" position
Vehicle speed: Higher than 40 km/h (25 MPH)
Engine speed: Higher than 1,500 rpm
Throttle position: 1.0/8 of the full throttle position
3. Perform self-diagnosis. Refer to [AT-82, "Diagnosis Procedure without CONSULT-III"](#).
4. If the check result is NG, go to [AT-164, "Diagnosis Procedure"](#).

INPUT SPEED SENSOR A

< SERVICE INFORMATION >

Wiring Diagram - AT - PT/SEN

INFOID:000000005928230

AT-PT/SEN-01

— : DETECTABLE LINE FOR DTC
 - - - : NON-DETECTABLE LINE FOR DTC

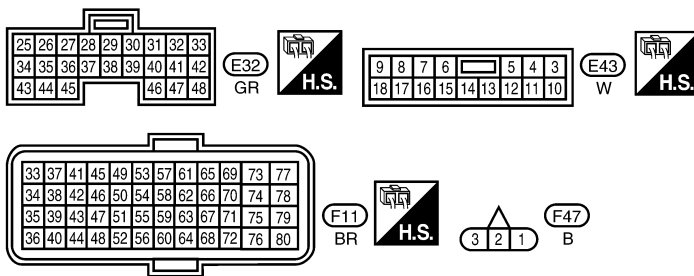
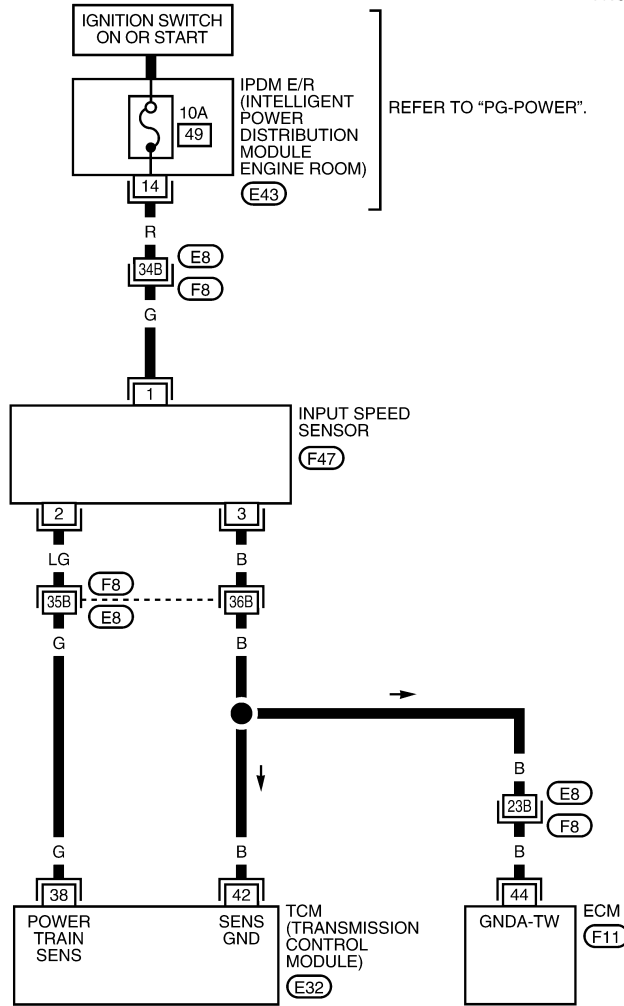

REFER TO THE FOLLOWING.

(F8) - SUPER MULTIPLE JUNCTION (SMJ)

TCM TERMINALS AND REFERENCE VALUES

Refer to [AT-75, "TCM Terminal and Reference Value"](#).

INPUT SPEED SENSOR A

< SERVICE INFORMATION >

Diagnosis Procedure

INFOID:000000005928231

1. CHECK INPUT SIGNAL

With CONSULT-III

1. Start engine.
2. Select "TCM INPUT SIGNALS" in "DATA MONITOR" mode for "TRANSMISSION" with CONSULT-III.
3. Read out the value of "INPUT SPEED" while driving. Check the value changes according to driving speed.

Item name	Condition	Display value
INPUT SPEED	During driving (lock-up ON)	Approximately matches the engine speed.

OK or NG

- OK >> GO TO 8.
 NG >> GO TO 2.

2. CHECK INPUT SPEED SENSOR

With CONSULT-III

1. Start engine.
2. Check power supply to input speed sensor by voltage between TCM connector terminals. Refer to [AT-168. "Wiring Diagram - AT - MAIN"](#) and [AT-163. "Wiring Diagram - AT - PT/SEN"](#).

Item	Connector	Terminal	Judgement standard (Approx.)
TCM	E31, E32	10 - 42	Battery voltage
		19 - 42	

3. If OK, check the pulse when vehicle cruises.

Name	Condition
Input speed sensor	When driving at 20 km/h (12 MPH), use the CONSULT-III pulse frequency measuring function.*1 CAUTION: Connect the diagnosis data link cable to the vehicle diagnosis connector. *1: A circuit tester cannot be used to test this item.

Item	Connector	Terminal	Name	Judgement standard (Approx.)
TCM	E32	38	Input speed sensor	360 Hz

OK or NG

- OK >> GO TO 8.
 NG >> GO TO 3.

3. CHECK POWER AND SENSOR GROUND

1. Turn ignition switch OFF.
2. Disconnect the input speed sensor harness connector.
3. Turn ignition switch ON.

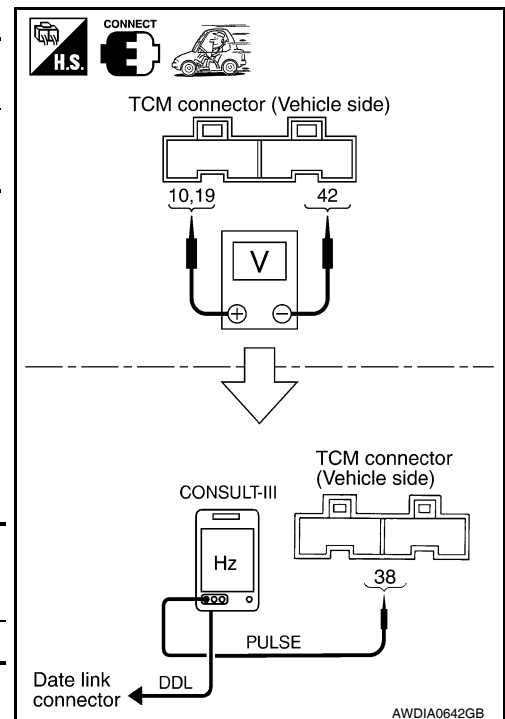

INPUT SPEED SENSOR A

< SERVICE INFORMATION >

4. Check voltage between input speed sensor harness connector terminals.

Item	Connector	Terminal	Judgement standard (Approx.)
Input speed sensor	F47	1 - 3	Battery voltage

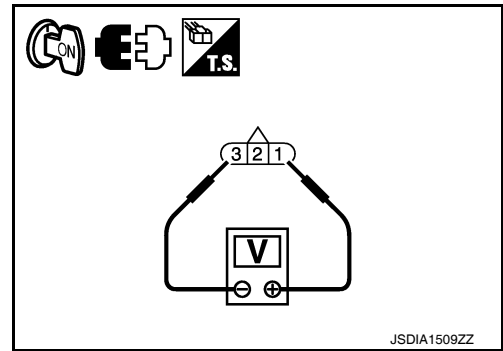

5. Check voltage between input speed sensor harness connector terminal and ground.

Item	Connector	Terminal	Judgement standard (Approx.)
Input speed sensor	F47	1 - ground	Battery voltage

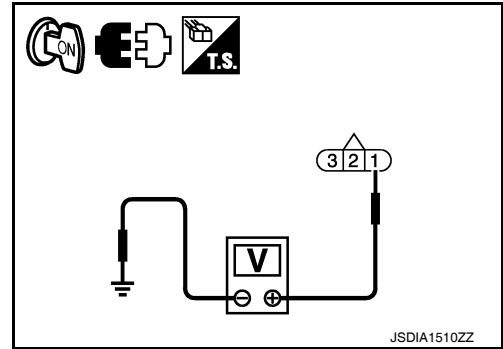

6. If OK, check harness for short to ground and short to power.
7. Reinstall any part removed.

OK or NG

OK >> GO TO 4.

NG - 1 >> Battery voltage is not supplied between terminals 1 and 3, terminals 1 and ground: GO TO 6.

NG - 2 >> Battery voltage is not supplied between terminals 1 and 3 only: GO TO 7.

4. CHECK HARNESS BETWEEN TCM AND INPUT SPEED SENSOR

1. Turn ignition switch OFF.
2. Disconnect the input speed sensor harness connector.
3. Check continuity between TCM connector (A) terminal and input speed sensor harness connector (B) terminal.

Item	Connector	Terminal	Continuity
TCM	E32	38	Yes
Input speed sensor	F47	2	

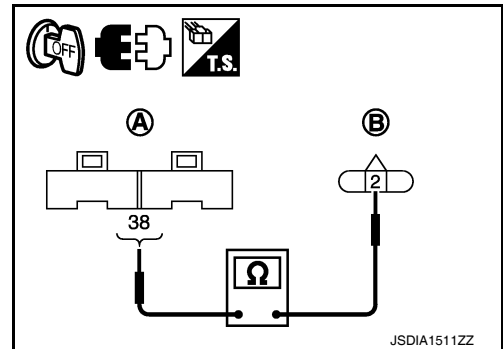

4. If OK, check harness for short to ground and short to power.
5. Reinstall any part removed.

OK or NG

OK >> GO TO 5.

NG >> Repair open circuit or short to ground or short to power in harness or connectors.

5. CHECK TCM

1. Check TCM input/output signal. Refer to [AT-75. "TCM Terminal and Reference Value"](#).
2. If NG, re-check TCM pin terminals for damage or loose connection with harness connector.

OK or NG

OK >> GO TO 8.

NG >> Repair or replace damaged parts.

6. CHECK HARNESS BETWEEN TCM AND INPUT SPEED SENSOR (POWER)

1. Turn ignition switch OFF.
2. Disconnect the input speed sensor harness connector.

INPUT SPEED SENSOR A

< SERVICE INFORMATION >

- Check continuity between TCM connector (A) terminals and input speed sensor harness connector (B) terminal. Refer to [AT-50. "Circuit Diagram"](#) and [AT-168. "Wiring Diagram - AT - MAIN"](#)

Item	Connector	Terminal	Continuity
TCM	E31	10	Yes
Input speed sensor	F47	1	
TCM	E31	19	Yes
Input speed sensor	F47	1	

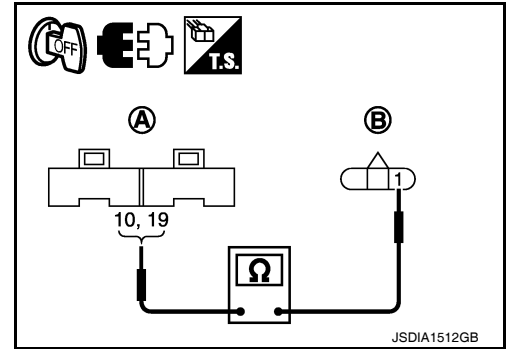

- If OK, check harness for short to ground and short to power.
- Reinstall any part removed.

OK or NG

- OK >> 10A fuse (No.49, located in the IPDM E/R) or ignition switch are malfunctioning.
 NG >> Repair open circuit or short to ground or short to power in harness or connectors.

7. CHECK HARNESS BETWEEN TCM AND INPUT SPEED SENSOR (GROUND)

- Turn ignition switch OFF.
- Disconnect the input speed sensor harness connector.
- Check continuity between TCM connector (A) terminal and input speed sensor harness connector (B) terminal.

Item	Connector	Terminal	Continuity
TCM	E32	42	Yes
Input speed sensor	F47	3	

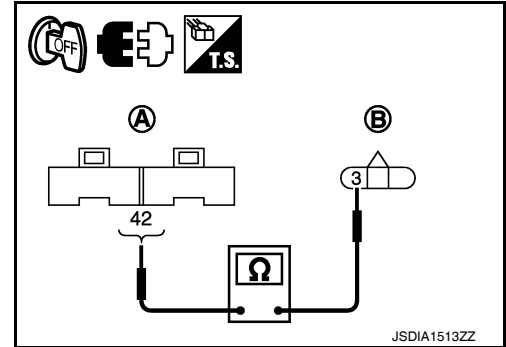

- If OK, check harness for short to ground and short to power.
- Reinstall any part removed.

OK or NG

- OK >> GO TO 5.
 NG >> Repair open circuit or short to ground or short to power in harness or connectors.

8. CHECK DTC

Perform [AT-162. "DTC Confirmation Procedure"](#) .

OK or NG

- OK >> **INSPECTION END**
 NG >> GO TO 5.

CONTROL UNIT (RAM), CONTROL UNIT (ROM)

< SERVICE INFORMATION >

CONTROL UNIT (RAM), CONTROL UNIT (ROM)

Description

INFOID:000000005928232

The TCM consists of a microcomputer and connectors for signal input and output and for power supply. The unit controls the A/T.

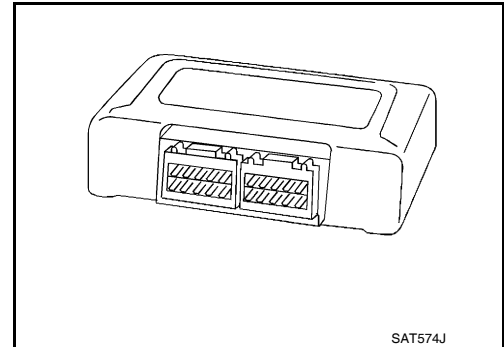

On Board Diagnosis Logic

INFOID:000000005928233

- This is not an OBD-II self-diagnostic item.
- Diagnostic trouble code “CONTROL UNIT (RAM)”, “CONTROL UNIT (ROM)” with CONSULT-III is detected when TCM memory (RAM) or (ROM) is malfunctioning.

Possible Cause

INFOID:000000005928234

TCM.

DTC Confirmation Procedure

INFOID:000000005928235

CAUTION:

If performing this “DTC Confirmation Procedure” again, always turn ignition switch OFF and wait at least 10 seconds before continuing.

After the repair, perform the following procedure to confirm the malfunction is eliminated.

④ WITH CONSULT-III

1. Turn ignition switch ON and select “DATA MONITOR” mode for “TRANSMISSION” with CONSULT-III.
2. Touch “START”.
3. Start engine.
4. Run engine for at least 2 seconds at idle speed.
5. If the check result is NG, go to [AT-167. "Diagnosis Procedure"](#).

Diagnosis Procedure

INFOID:000000005928236

1. CHECK DTC

④ With CONSULT-III

1. Turn ignition switch ON and select “SELF-DIAG RESULTS” mode for “TRANSMISSION” with CONSULT-III.
2. Touch “ERASE”.
3. Perform [AT-167. "DTC Confirmation Procedure"](#).

Is the “CONTROL UNIT (RAM)” or “CONTROL UNIT (ROM)” displayed again?

- YES >> Replace TCM. Refer to [AT-212. "Removal and Installation"](#).
NO >> **INSPECTION END**

MAIN POWER SUPPLY AND GROUND CIRCUIT

< SERVICE INFORMATION >

MAIN POWER SUPPLY AND GROUND CIRCUIT

Wiring Diagram - AT - MAIN

INFOID:000000005928237

AT-MAIN-01

— : DETECTABLE LINE FOR DTC
 - - - : NON-DETECTABLE LINE FOR DTC

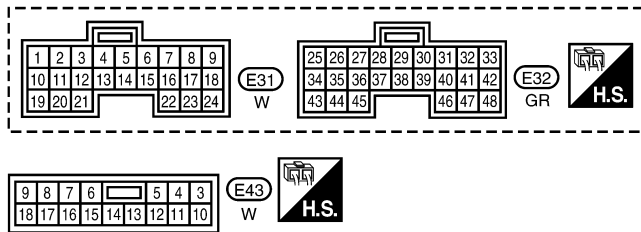
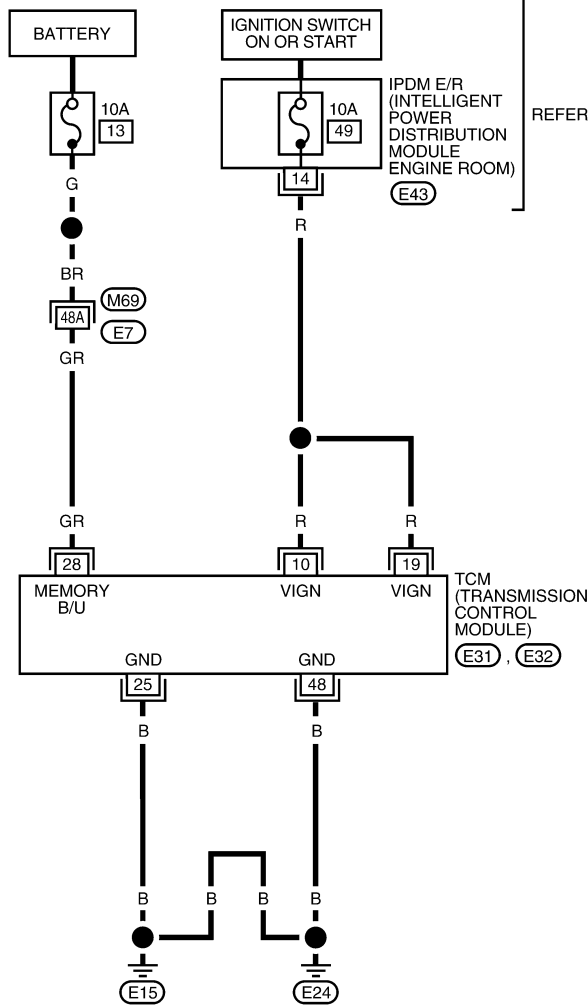

REFER TO THE FOLLOWING.

(M69) - SUPER MULTIPLE JUNCTION (SMJ)

ABDWA0215GB

TCM TERMINALS AND REFERENCE VALUES

Refer to [AT-75. "TCM Terminal and Reference Value"](#).

MAIN POWER SUPPLY AND GROUND CIRCUIT

< SERVICE INFORMATION >

Diagnosis Procedure

INFOID:000000005928238

1. CHECK TCM POWER SOURCE

1. Turn ignition switch ON. (Do not start engine.)
2. Check voltage between TCM connector terminals and ground.

Item	Connector	Terminal	Judgement standard (Approx.)
Power supply	E31	10	Battery voltage
		19	Battery voltage
Power supply (memory back-up)	E32	28	Battery voltage

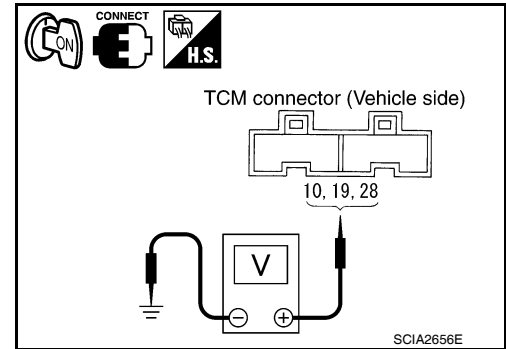

3. Turn ignition switch OFF.
4. Check voltage between TCM connector terminals and ground.

Item	Connector	Terminal	Judgement standard (Approx.)
Power supply	E31	10	0 V
		19	0 V
Power supply (memory back-up)	E32	28	Battery voltage

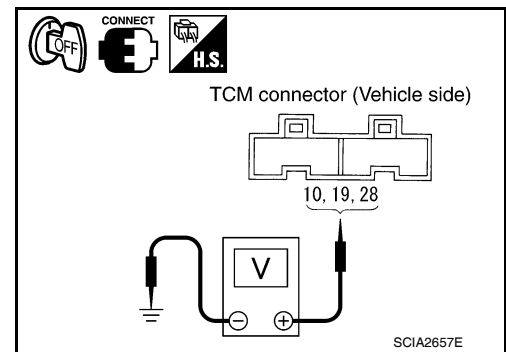

OK or NG

- OK >> GO TO 3.
 NG >> GO TO 2.

2. DETECT MALFUNCTIONING ITEM

Check the following items:

- Harness for short or open between ignition switch and TCM terminals 10, 19
- Harness for short or open between battery and TCM terminal 28
- 10A fuse (No.13, located in the fuse block) and 10A fuse (No.49, located in the IPDM E/R)
- Ignition switch. Refer to [PG-4](#).

OK or NG

- OK >> GO TO 3.
 NG >> Repair or replace damaged parts.

3. CHECK TCM GROUND CIRCUIT

1. Turn ignition switch OFF.
2. Check continuity between TCM connector terminals and ground.

Item	Connector	Terminal	Continuity
Ground	E32	25, 48 - Ground	Yes

OK or NG

- OK >> GO TO 4.
 NG >> Repair open circuit or short to ground or short to power in harness or connectors.

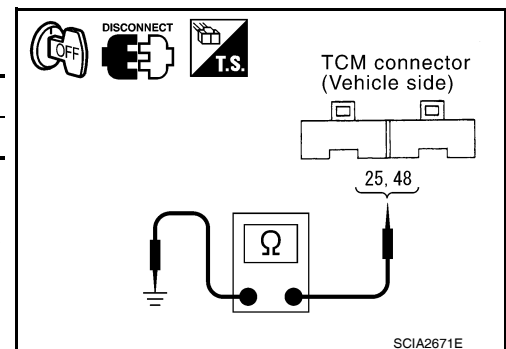

4. CHECK SYMPTOM

Drive for a while to check that there is no malfunction.

OK or NG

MAIN POWER SUPPLY AND GROUND CIRCUIT

< SERVICE INFORMATION >

OK >> **INSPECTION END**

NG >> GO TO 5.

5.CHECK TCM

1. Check TCM input/output signal. Refer to [AT-75. "TCM Terminal and Reference Value"](#) .

2. If NG, recheck TCM pin terminals for damage or loose connection with harness connector.

OK or NG

OK >> **INSPECTION END**

NG >> Repair or replace damaged parts.

TR SW, OD SW AND CLOSED THROTTLE, WIDE OPEN THROTTLE POSITION SIGNAL CIRCUIT

< SERVICE INFORMATION >

TR SW, OD SW AND CLOSED THROTTLE, WIDE OPEN THROTTLE POSITION SIGNAL CIRCUIT

CONSULT-III Reference Value in Data Monitor Mode

INFOID:000000005928239

Item name	Condition	Display value
PN POSI SW	When setting selector lever to "N" or "P" position.	ON
	When setting selector lever to other positions.	OFF
R POSITION SW	When setting selector lever to "R" position.	ON
	When setting selector lever to other positions.	OFF
D POSITION SW	When setting selector lever to "D" position.	ON
	When setting selector lever to other positions.	OFF
2 POSITION SW	When setting selector lever to "2" position.	ON
	When setting selector lever to other positions.	OFF
1 POSITION SW	When setting selector lever to "1" position.	ON
	When setting selector lever to other positions.	OFF
OVERDRIVE SW	When overdrive control switch is depressed.	ON
	When overdrive control switch is released.	OFF
CLOSED THL/SW	Released accelerator pedal.	ON
	Depressed accelerator pedal.	OFF
W/O THRL/P-SW	Fully depressed accelerator pedal.	ON
	Released accelerator pedal.	OFF

TCM Terminal and Reference Value

INFOID:000000005928240

TCM terminal data are reference values, measured between each terminal and ground.

Terminal	Wire color	Item	Condition	Judgement standard (Approx.)
26	Y	Transmission range switch "1" position	When setting selector lever to "1" position.	Battery voltage
			When setting selector lever to other positions.	0 V
27	G	Transmission range switch "2" position	When setting selector lever to "2" position.	Battery voltage
			When setting selector lever to other positions.	0 V
34	LG	Transmission range switch "D" position	When setting selector lever to "D" position.	Battery voltage
			When setting selector lever to other positions.	0 V
35	SB	Transmission range switch "R" position	When setting selector lever to "R" position.	Battery voltage
			When setting selector lever to other positions.	0 V
36	R	Transmission range switch "N" or "P" position	When setting selector lever to "N" or "P" positions.	Battery voltage
			When setting selector lever to other positions.	0 V

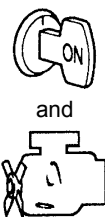

Diagnosis Procedure

INFOID:000000005928241

1. CHECK CAN COMMUNICATION LINE

Perform self-diagnosis. Refer to [AT-77. "CONSULT-III Function \(TRANSMISSION\)"](#).

Is a malfunction in the CAN communication indicated in the results?

YES >> Check CAN communication line. Refer to [AT-87](#).

NO (With CONSULT-III) >>GO TO 2.

NO (Without CONSULT-III) >>GO TO 3.

TR SW, OD SW AND CLOSED THROTTLE, WIDE OPEN THROTTLE POSITION SIGNAL CIRCUIT

< SERVICE INFORMATION >

2. CHECK TRANSMISSION RANGE SWITCH CIRCUIT

With CONSULT-III

1. Turn ignition switch ON. (Do not start engine.)
2. Select "TCM INPUT SIGNALS" in "DATA MONITOR" mode for "TRANSMISSION" with CONSULT-III.
3. Read out "P·N", "R", "D", "2" and "1" position switches moving selector lever to each position.

Item name	Condition	Display value
PN POSI SW	When setting selector lever to "N" or "P" position.	ON
	When setting selector lever to other positions.	OFF
R POSITION SW	When setting selector lever to "R" position.	ON
	When setting selector lever to other positions.	OFF
D POSITION SW	When setting selector lever to "D" positions.	ON
	When setting selector lever to other positions.	OFF
2 POSITION SW	When setting selector lever to "2" position.	ON
	When setting selector lever to other positions.	OFF
1 POSITION SW	When setting selector lever to "1" position.	ON
	When setting selector lever to other positions.	OFF

OK or NG

- OK >> GO TO 4.
 NG >> Check transmission range switch circuit. Refer to [AT-90](#).

3. CHECK TRANSMISSION RANGE SWITCH CIRCUIT

Without CONSULT-III

1. Turn ignition switch ON. (Do not start engine.)
2. Check voltage between TCM connector terminals and ground while moving selector lever through each position. Refer to [AT-91](#). "[Wiring Diagram - AT - TR/SW](#)".

Selector lever position	Terminal				
	36	35	34	27	26
"P", "N"	B	0	0	0	0
"R"	0	B	0	0	0
"D"	0	0	B	0	0
"2"	0	0	0	B	0
"1"	0	0	0	0	B

B: Battery voltage

0: 0V

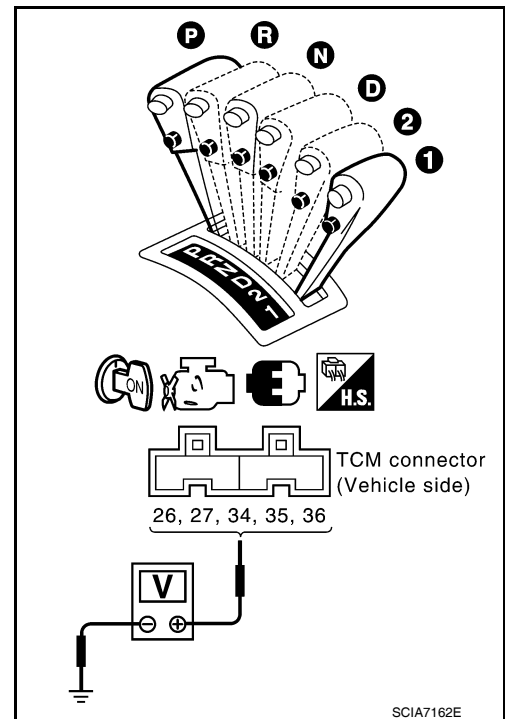

OK or NG

- OK >> GO TO 4.
 NG >> Check transmission range switch circuit. Refer to [AT-90](#).

TR SW, OD SW AND CLOSED THROTTLE, WIDE OPEN THROTTLE POSITION SIGNAL CIRCUIT

< SERVICE INFORMATION >

4. CHECK TRANSMISSION RANGE SWITCH

1. Turn ignition switch OFF.
2. Disconnect transmission range switch harness connector.
3. Check continuity between transmission range switch harness connector terminals.

Selector lever position	Connector	Terminal	Continuity
"P"	F25	1 - 2, 3 - 7	Yes *Continuity should not exist in positions other than the specified positions.
"R"		3 - 8	
"N"		1 - 2, 3 - 9	
"D"		3 - 6	
"2"		3 - 5	
"1"		3 - 4	

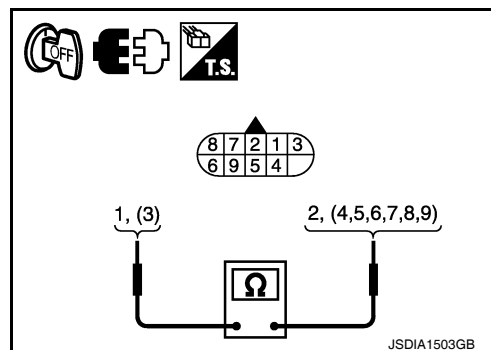

OK or NG

- OK >> GO TO 6.
NG >> GO TO 5.

5. CHECK CONTROL CABLE ADJUSTMENT

Check transmission range switch again with control cable disconnected from manual shaft of A/T assembly. Refer to test group 4.

OK or NG

- OK >> Adjust control cable. Refer to [AT-217, "Adjustment of A/T Position"](#).
NG >> Check transmission range switch (Refer to test group 1) again after adjusting transmission range switch (Refer to [AT-225](#)).
• If OK, **INSPECTION END**
• If NG, repair or replace transmission range switch. Refer to [AT-225, "Transmission Range Switch"](#).

6. DETECT MALFUNCTIONING ITEM

Check the following.

- Harness for short or open between ignition switch and transmission range switch
- Harness for short or open between transmission range switch and TCM
- Harness for short or open between transmission range switch and combination meter
- Harness for short or open between combination meter and TCM
- 10A fuse (No.51, located in the IPDM E/R)
- Combination meter. Refer to [DI-4](#).
- Ignition switch. Refer to [PG-4](#).

OK or NG

- OK >> GO TO 7.
NG >> Repair or replace damaged parts.

7. CHECK OVERDRIVE CONTROL SWITCH CIRCUIT

With CONSULT-III

1. Turn ignition switch ON. (Do not start engine.)
2. Select "TCM INPUT SIGNALS" in "DATA MONITOR" mode for "TRANSMISSION" with CONSULT-III.
3. Read out "OVERDRIVE SW". Check the signal of overdrive control switch is indicated properly.

Item name	Overdrive control switch Condition	Display value
OVERDRIVE SW	Depressed	ON
	Released	OFF

Without CONSULT-III

1. Turn ignition switch ON. (Do not start engine.)

TR SW, OD SW AND CLOSED THROTTLE, WIDE OPEN THROTTLE POSITION SIGNAL CIRCUIT

< SERVICE INFORMATION >

- Check voltage between A/T shift selector harness connector terminal and ground. Refer to [AT-177, "Wiring Diagram - AT - NON-DTC"](#).

Item	Connector	Terminal	Overdrive control switch Condition	Judgement standard (Approx.)
A/T shift selector harness connector (Overdrive control switch)	M38	1 - Ground	Released	Battery voltage
			Depressed	0 V

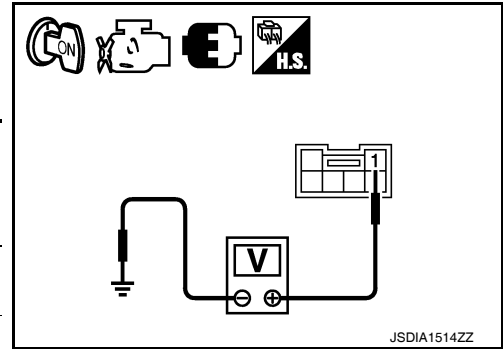

OK or NG

- OK >> GO TO 10.
- NG >> GO TO 8.

8. CHECK OVERDRIVE CONTROL SWITCH

- Turn ignition switch OFF.
- Disconnect A/T shift selector harness connector.
- Check continuity between A/T shift selector harness connector terminals. Refer to [AT-177, "Wiring Diagram - AT - NONDTC"](#).

Item	Connector	Terminal	Overdrive control switch condition	Continuity
A/T shift selector harness connector (Overdrive control switch)	M38	1 - 2	Released	No
			Depressed	Yes

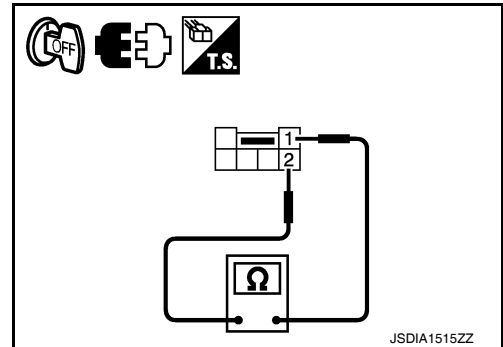

OK or NG

- OK >> GO TO 9.
- NG >> Repair or replace damaged parts.

9. DETECT MALFUNCTIONING ITEM

Check the following.

- Harness for short or open between combination meter and A/T shift selector harness connector
- Harness for short or open between A/T shift selector harness connector and ground
- Combination meter. Refer to [DI-4](#).

OK or NG

- OK >> GO TO 10.
- NG >> Repair or replace damaged parts.

10. CHECK CLOSED THROTTLE POSITION AND WIDE OPEN THROTTLE POSITION SIGNAL CIRCUIT

With CONSULT-III

- Turn ignition switch ON. (Do not start engine.)
- Select "TCM INPUT SIGNALS" in "DATA MONITOR" mode for TRANSMISSION with CONSULT-III.
- Read out "CLOSED THL/SW" and "W/O THRL/P-SW" depressing and releasing accelerator pedal. Check that the signals of throttle position are indicated properly.

Accelerator pedal condition	Data monitor	
	CLOSED THL/SW	W/O THRL/P-SW
Released	ON	OFF
Fully depressed	OFF	ON

OK or NG

- OK >> GO TO 11.
- NG >> Check the following. If any items are damaged, repair or replace damaged parts.
 - Accelerator pedal position sensor. Refer to [EC-402, "Description"](#) (HR16DE), [EC-965, "Component Description"](#) (MR18DE).

TR SW, OD SW AND CLOSED THROTTLE, WIDE OPEN THROTTLE POSITION SIGNAL CIRCUIT

< SERVICE INFORMATION >

11. PERFORM SELF-DIAGNOSIS

⊗ Without CONSULT-III

Perform self-diagnosis. Refer to [AT-82. "Diagnosis Procedure without CONSULT-III"](#).

OK or NG

OK >> **INSPECTION END**

NG – 1 >> Self-diagnosis does not activate: GO TO 12.

NG – 2 >> DTC is displayed: Check the malfunctioning system. Refer to [AT-82. "Diagnosis Procedure without CONSULT-III"](#).

12. CHECK TCM

1. Check TCM input/output signal. Refer to [AT-75. "TCM Terminal and Reference Value"](#).
2. If NG, recheck TCM pin terminals for damage or loose connection with harness connector.

OK or NG

OK >> **INSPECTION END**

NG >> Repair or replace damaged parts.

Component Inspection

INFOID:000000005928242

OVERDRIVE CONTROL SWITCH

- Check continuity between A/T shift selector harness connector terminals.

Item	Connector	Terminal	Overdrive control switch condition	Continuity
A/T shift selector harness connector (Overdrive control switch)	M38	1 - 2	Released	No
			Depressed	Yes

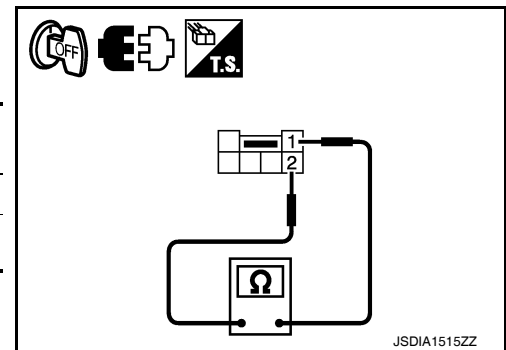

TRANSMISSION RANGE SWITCH

1. Check continuity between transmission range switch harness connector terminals.

Selector lever position	Connector	Terminal	Continuity
"P"	F25	1 - 2, 3 - 7	Yes
"R"		3 - 8	*Continuity should not exist in positions other than the specified positions.
"N"		1 - 2, 3 - 9	
"D"		3 - 6	
"2"		3 - 5	
"1"		3 - 4	

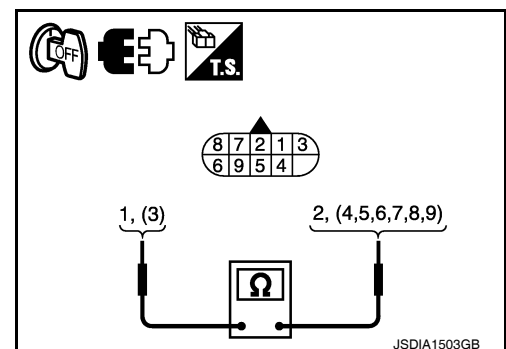

2. If NG, check again with control cable (2) disconnected from manual shaft (3) of A/T assembly. Refer to step 1. (1): Lock nut
3. If OK on step 2, adjust control cable (2). Refer to [AT-217. "Adjustment of A/T Position"](#).
4. If NG on step 2, remove transmission range switch from A/T assembly and check continuity of transmission range switch terminals. Refer to step 1.
5. If OK on step 4, adjust transmission range switch. Refer to [AT-225. "Transmission Range Switch"](#).
6. If NG on step 4, replace transmission range switch. Refer to [AT-225. "Transmission Range Switch"](#).

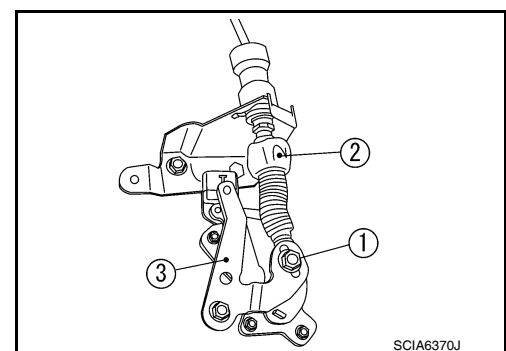

SHIFT POSITION INDICATOR CIRCUIT

< SERVICE INFORMATION >

SHIFT POSITION INDICATOR CIRCUIT

Description

INFOID:000000005928243

TCM sends the switch signals to combination meter via CAN communication line. Then selector lever position is indicated on the shift position indicator.

CONSULT-III Reference Value in Data Monitor Mode

INFOID:000000005928244

Item name	Condition	Display value
SLCT LVR POSI	When setting selector lever to "N" or "P" positions.	N · P
	When setting selector lever to "R" position.	R
	When setting selector lever to "D" position.	D
	When setting selector lever to "2" position.	2
	When setting selector lever to "1" position.	1

Diagnosis Procedure

INFOID:000000005928245

1. CHECK INPUT SIGNALS

With CONSULT-III

1. Start engine.
2. Select "MAIN SIGNALS" in "DATA MONITOR" mode for "TRANSMISSION" with CONSULT-III and read out the value of "SLCT LVR POSI".
3. Check that the following three positions or indicators are same.
 - Actual position of the selector lever
 - "SLCT LVR POSI" on CONSULT-III screen
 - Shift position indicator in the combination meter

OK or NG

- OK >> **INSPECTION END**
NG >> Check the following.

SHIFT POSITION INDICATOR SYMPTOM CHART

Items	Presumed location of trouble
Actual position does not change.	Transmission range switch <ul style="list-style-type: none">• Refer to AT-90. A/T main system (Fail-safe function actuated) <ul style="list-style-type: none">• Refer to AT-77, "CONSULT-III Function (TRANSMISSION)" and AT-82, "Diagnosis Procedure without CONSULT-III".
Shift position indicator in the combination meter does not indicate any position.	Perform the self-diagnosis for A/T and the combination meter. <ul style="list-style-type: none">• Refer to AT-77, "CONSULT-III Function (TRANSMISSION)" and DI-4.
Actual position changes, but the shift position indicator in the combination meter does not change.	
Actual position differs from the shift position indicator in the combination meter.	
Shift position indicator in the combination meter does not indicate specific position only.	Check the combination meter. <ul style="list-style-type: none">• Refer to DI-4.

TROUBLE DIAGNOSIS FOR SYMPTOMS

< SERVICE INFORMATION >

TROUBLE DIAGNOSIS FOR SYMPTOMS

Wiring Diagram - AT - NONDTC

INFOID:000000005928246

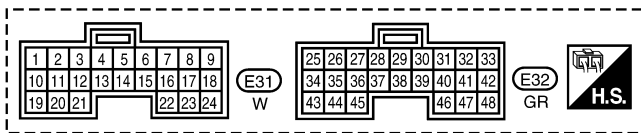
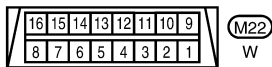
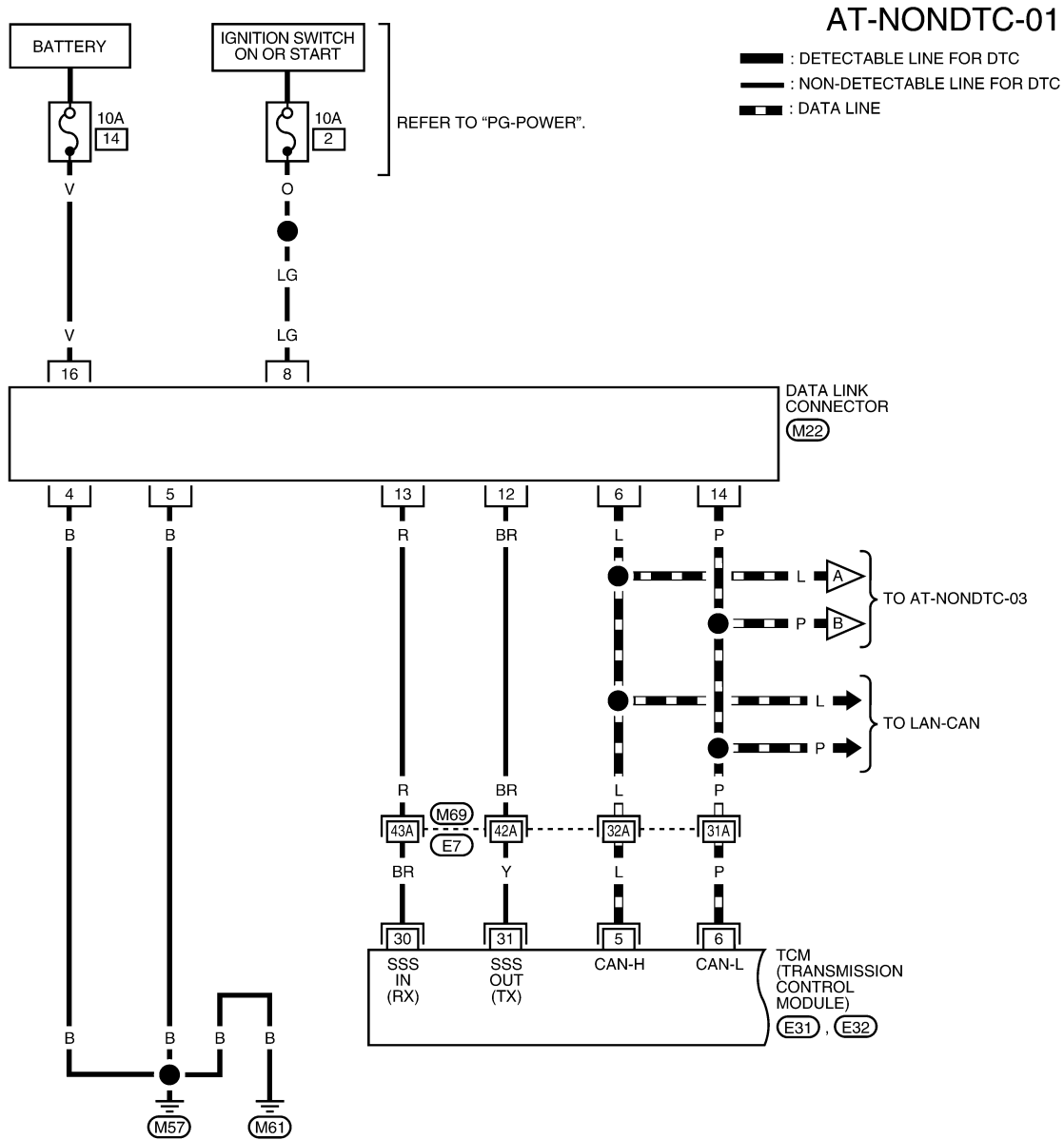

REFER TO THE FOLLOWING.

(M69) - SUPER MULTIPLE JUNCTION (SMJ)

BCWA0662E

TROUBLE DIAGNOSIS FOR SYMPTOMS

< SERVICE INFORMATION >

AT-NONDTC-02

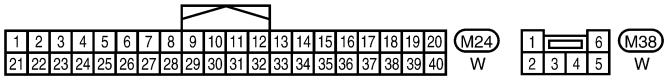
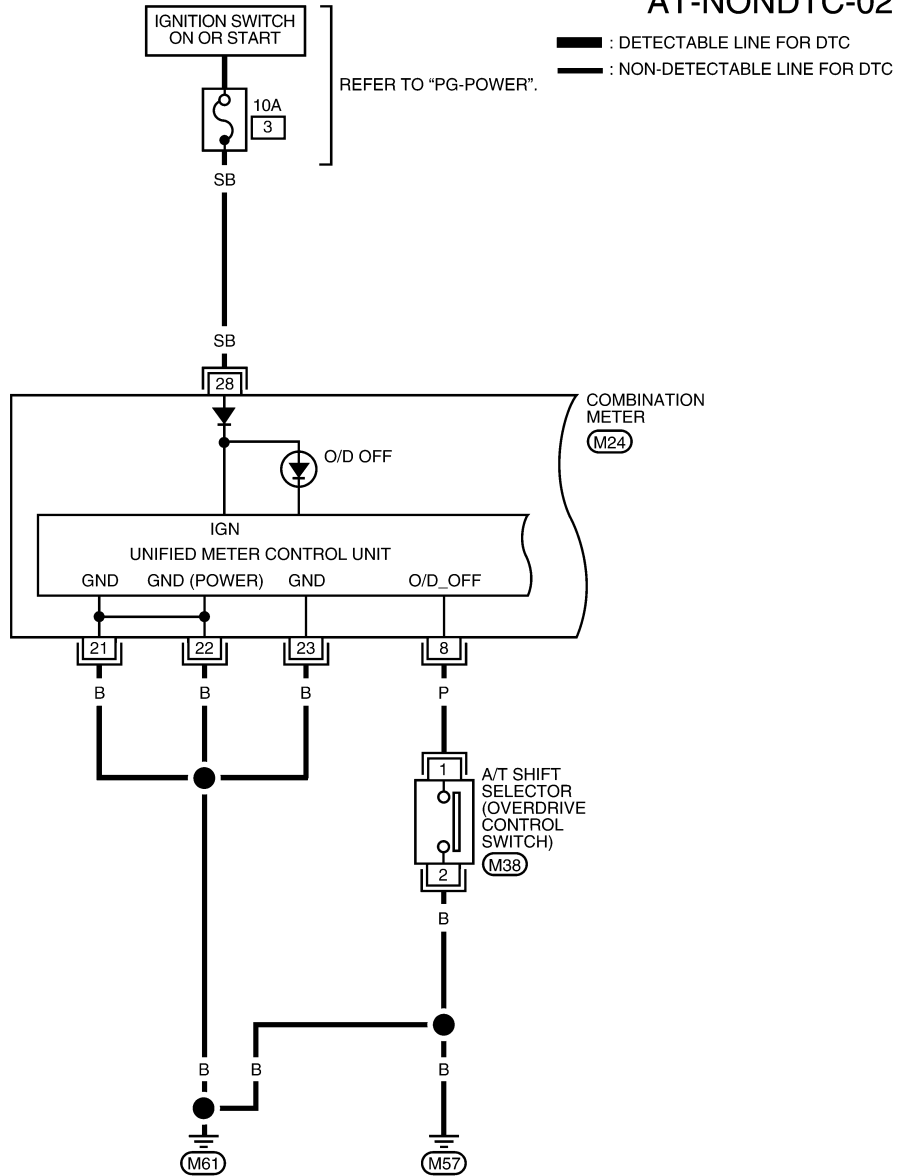

ABDWA0415GB

TROUBLE DIAGNOSIS FOR SYMPTOMS

< SERVICE INFORMATION >

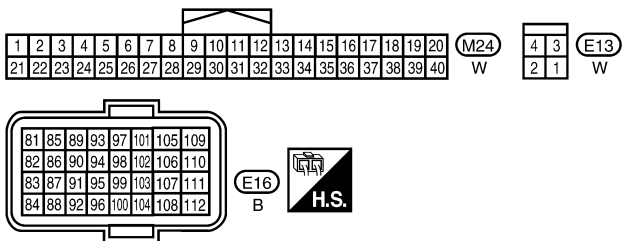
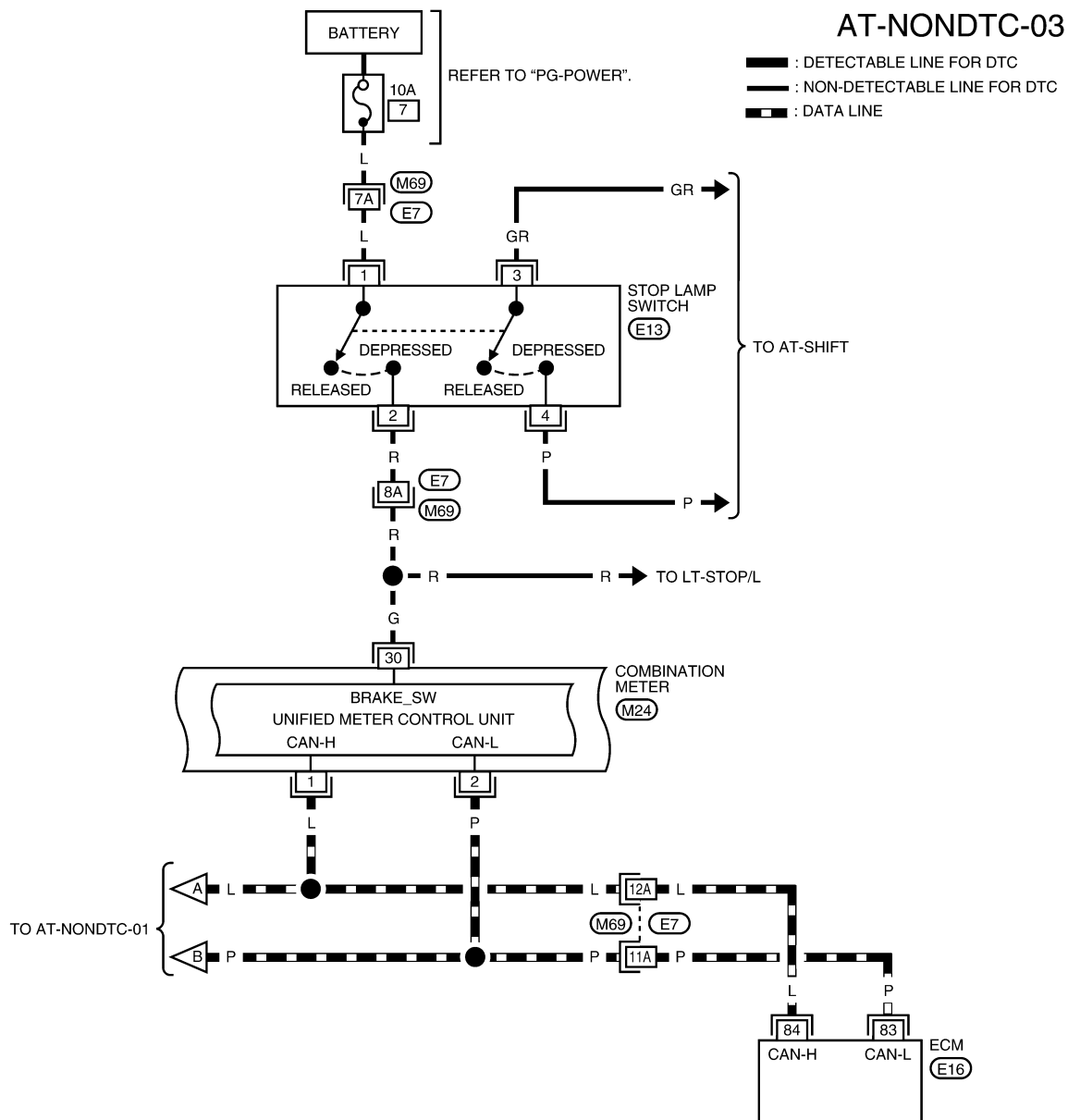

REFER TO THE FOLLOWING.
 (M69) - SUPER MULTIPLE JUNCTION (SMJ)

ABDWA0416GB

TROUBLE DIAGNOSIS FOR SYMPTOMS

< SERVICE INFORMATION >

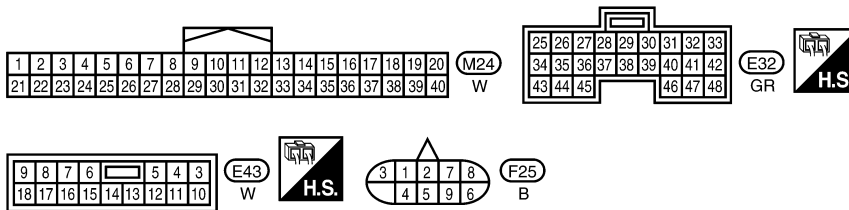
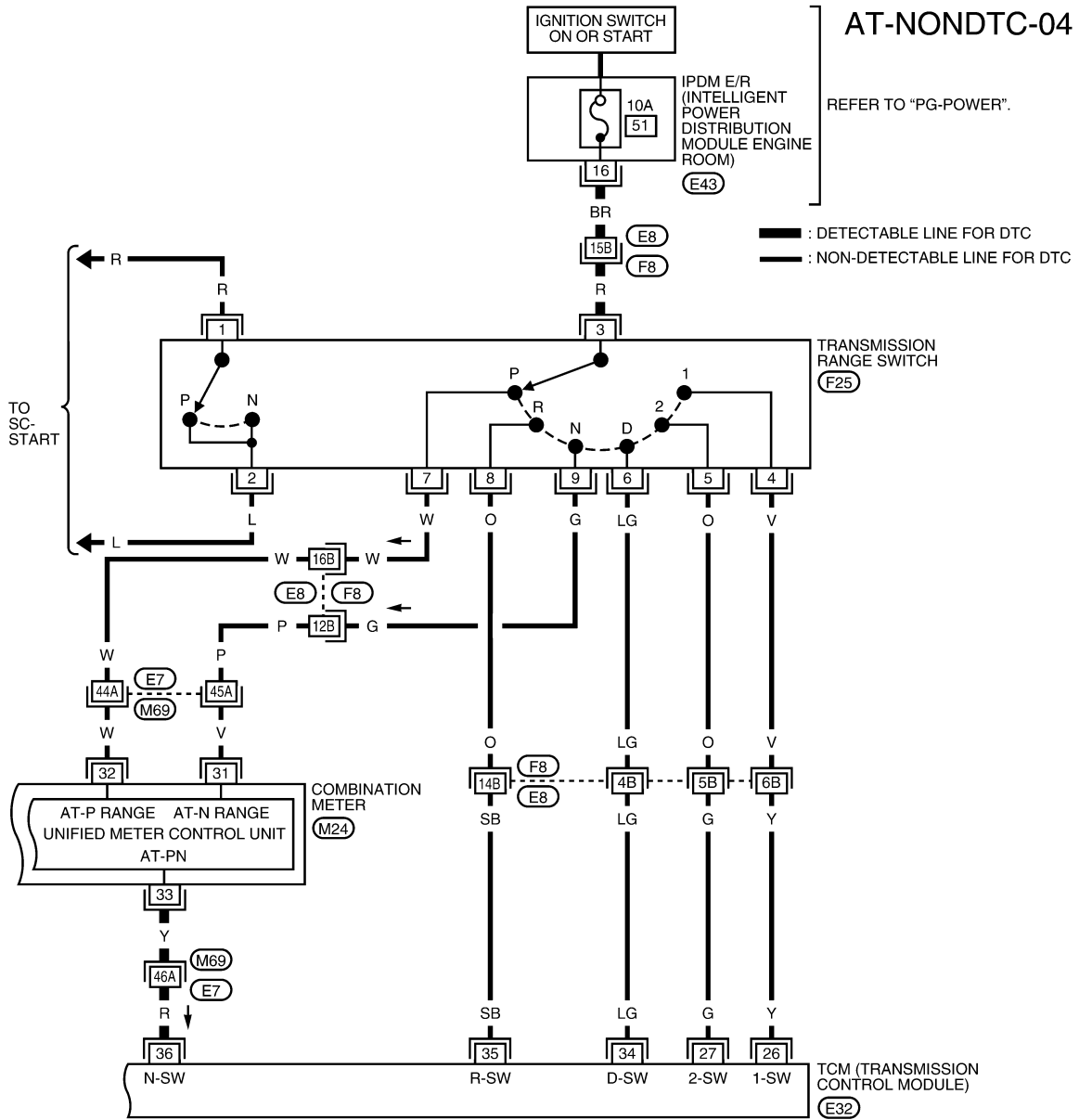

REFER TO THE FOLLOWING.
 (M69), (F8) - SUPER
 MULTIPLE JUNCTION (SMJ)

ABDWA0417GB

TCM TERMINALS AND REFERENCE VALUES
 Refer to [AT-75. "TCM Terminal and Reference Value"](#).

OD OFF Indicator Lamp Does Not Come On

INFOID:000000005928247

SYMPTOM:

Revision: May 2010

AT-180

2011 Versa

TROUBLE DIAGNOSIS FOR SYMPTOMS

< SERVICE INFORMATION >

OD OFF indicator lamp does not come on for about 2 seconds when turning ignition switch to ON.

DIAGNOSTIC PROCEDURE

1. CHECK CAN COMMUNICATION LINE

Perform self-diagnosis. Refer to [AT-77, "CONSULT-III Function \(TRANSMISSION\)"](#).

Is a malfunction in CAN communication indicated in the results?

- YES >> Check CAN communication line. Refer to [AT-87](#).
- NO >> GO TO 2.

2. CHECK TCM POWER SOURCE

1. Turn ignition switch ON. (Do not start engine.)
2. Check voltage between TCM connector terminals and ground. Refer to [AT-168, "Wiring Diagram - AT - MAIN"](#).

Item	Connector	Terminal	Judgement standard (Approx.)
TCM connector	E31	10 - Ground	Battery voltage
		19 - Ground	
	E32	28 - Ground	

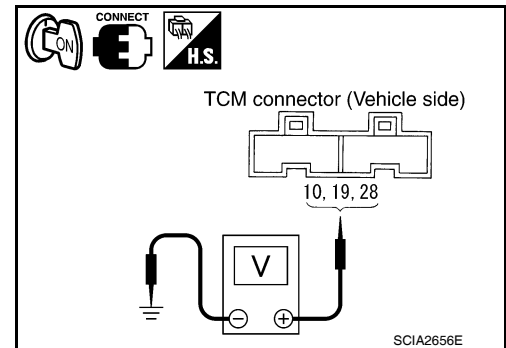

3. Turn ignition switch OFF.
4. Check voltage between TCM connector terminals and ground.

Item	Connector	Terminal	Judgement standard (Approx.)
TCM connector	E31	10 - Ground	0V
		19 - Ground	0V
	E32	28 - Ground	Battery voltage

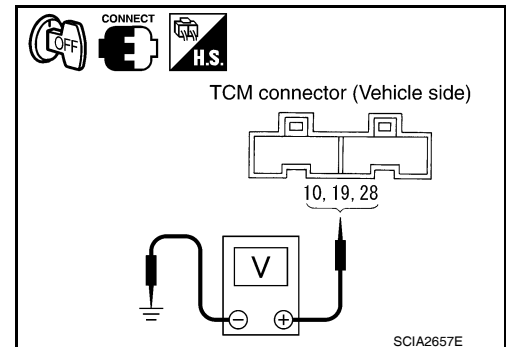

OK or NG

- OK >> GO TO 4.
- NG >> GO TO 3.

3. DETECT MALFUNCTIONING ITEM

Check the following.

- Harness for short or open between ignition switch and TCM connector terminals 10, 19. Refer to [AT-168, "Wiring Diagram - AT - MAIN"](#).
- Harness for short or open between battery and TCM connector terminal 28. Refer to [AT-168, "Wiring Diagram - AT - MAIN"](#).
- 10A fuse (No.13, located in the fuse block) and 10A fuse (No.49, located in the IPDM E/R). Refer to [AT-168, "Wiring Diagram - AT - MAIN"](#).
- Ignition switch. Refer to [PG-4](#).

OK or NG

- OK >> GO TO 4.
- NG >> Repair or replace damaged parts.

4. CHECK TCM GROUND CIRCUIT

1. Turn ignition switch OFF.
2. Disconnect TCM connector.

TROUBLE DIAGNOSIS FOR SYMPTOMS

< SERVICE INFORMATION >

- Check continuity between TCM connector terminals and ground.
Refer to [AT-168, "Wiring Diagram - AT - MAIN"](#).

Item	Connector	Terminal	Continuity
TCM connector	E32	25, 48 - Ground	Yes

OK or NG

- OK >> GO TO 5.
- NG >> Repair open circuit or short to ground or short to power in harness or connectors.

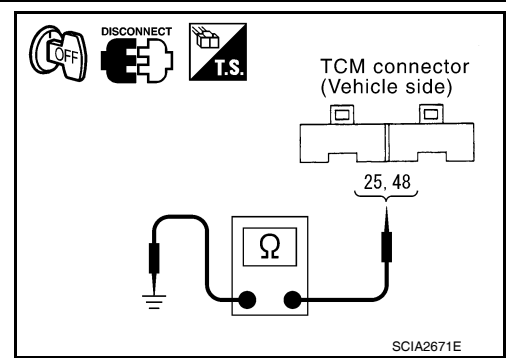

5. DETECT MALFUNCTIONING ITEM

Check the following.

- Harness for short or open between ignition switch and combination meter
- Combination meter. Refer to [DI-4](#).

OK or NG

- OK >> GO TO 6.
- NG >> Repair or replace damaged parts.

6. CHECK SYMPTOM

Check again. Refer to [AT-56, "Check Before Engine Is Started"](#).

OK or NG

- OK >> **INSPECTION END**
- NG >> GO TO 7.

7. CHECK TCM

- Check TCM input/output. Refer to [AT-75, "TCM Terminal and Reference Value"](#).
- If NG, recheck TCM pin terminals for damage or loose connection with harness connector.

OK or NG

- OK >> **INSPECTION END**
- NG >> Repair or replace damaged parts.

Engine Cannot Be Started in "P" and "N" Position

INFOID:000000005928248

SYMPTOM:

- Engine cannot be started with selector lever in "P" or "N" position.
- Engine can be started with selector lever in "D", "2", "1" or "R" position.

DIAGNOSTIC PROCEDURE

1. CHECK TRANSMISSION RANGE SWITCH

Check continuity between transmission range switch harness connector terminals. Refer to [AT-91, "Wiring Diagram - AT - TR/SW"](#).

Selector lever position	Connector	terminal	Continuity
"P", "N"	F25	1 - 2	Yes
Other positions			No

OK or NG

- OK >> GO TO 3.
- NG >> GO TO 2.

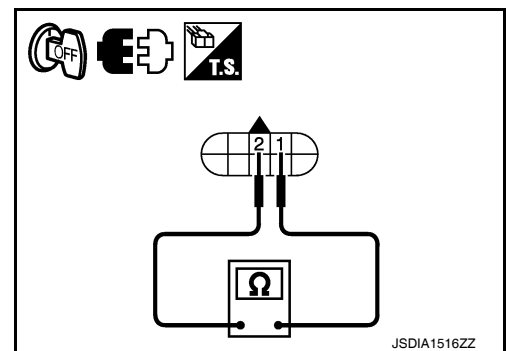

2. CHECK TRANSMISSION RANGE SWITCH

Check transmission range switch again with control cable disconnected from manual shaft of A/T assembly. Refer to test group 1.

OK or NG

- OK >> Adjust A/T position. Refer to [AT-217, "Adjustment of A/T Position"](#).

TROUBLE DIAGNOSIS FOR SYMPTOMS

< SERVICE INFORMATION >

- NG >> 1. Check transmission range switch (Refer to test group 1.) again after adjusting transmission range switch (Refer to [AT-225](#)).
- If OK, **INSPECTION END**
 - If NG, repair or replace transmission range switch. Refer to [AT-225, "Transmission Range Switch"](#).

3.CHECK STARTING SYSTEM

Check starting system. Refer to [SC-9](#).

OK or NG

- OK >> **INSPECTION END**
- NG >> Repair or replace damaged parts.

In "P" Position, Vehicle Moves Forward or Backward When Pushed

INFOID:000000005928249

SYMPTOM:

Vehicle moves when it is pushed forward or backward with selector lever in "P" position.

DIAGNOSTIC PROCEDURE

1.CHECK A/T POSITION

Check A/T position. Refer to [AT-217, "Checking of A/T Position"](#).

OK or NG

- OK >> GO TO 2.
- NG >> Adjust A/T position. Refer to [AT-217, "Adjustment of A/T Position"](#).

2.CHECK PARKING COMPONENTS

Check parking components. Refer to [AT-237, "Component"](#) and [AT-257](#).

OK or NG

- OK >> **INSPECTION END**
- NG >> Repair or replace damaged parts.

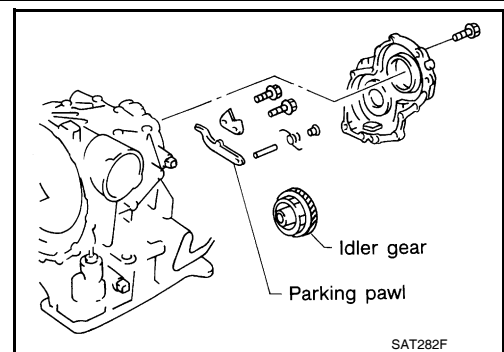

In "N" Position, Vehicle Moves

INFOID:000000005928250

SYMPTOM:

Vehicle moves forward or backward when selecting "N" position.

DIAGNOSTIC PROCEDURE

1.CHECK A/T POSITION

Check A/T position. Refer to [AT-217, "Checking of A/T Position"](#).

OK or NG

- OK >> GO TO 2.
- NG >> Adjust A/T position. Refer to [AT-217, "Adjustment of A/T Position"](#).

2.CHECK A/T FLUID LEVEL

Check A/T fluid level. Refer to [AT-17, "Checking A/T Fluid"](#).

OK or NG

- OK >> GO TO 3.
- NG >> Refill ATF.

3.CHECK A/T FLUID CONDITION

1. Remove oil pan. Refer to [AT-237, "Component"](#).

TROUBLE DIAGNOSIS FOR SYMPTOMS

< SERVICE INFORMATION >

2. Check A/T fluid condition. Refer to [AT-51, "Inspections Before Trouble Diagnosis"](#) .

OK or NG

- OK >> GO TO 5.
- NG >> GO TO 4.

4. DETECT MALFUNCTIONING ITEM

1. Disassemble A/T. Refer to [AT-257, "Disassembly"](#) .
2. Check the following items:
 - Forward clutch assembly. Refer to [AT-307, "Forward and Overrun Clutches"](#) .
 - Overrun clutch assembly. Refer to [AT-307, "Forward and Overrun Clutches"](#) .
 - Reverse clutch assembly. Refer to [AT-297, "Reverse Clutch"](#) .

OK or NG

- OK >> GO TO 5.
- NG >> Repair or replace damaged parts.

5. CHECK SYMPTOM

Check again. Refer to [AT-56, "Check at Idle"](#) .

OK or NG

- OK >> **INSPECTION END**
- NG >> GO TO 6.

6. CHECK TCM

1. Check TCM input/output signals. Refer to [AT-75, "TCM Terminal and Reference Value"](#) .
2. If NG, recheck TCM pin terminals for damage or loose connection with harness connector.

OK or NG

- OK >> **INSPECTION END**
- NG >> Repair or replace damaged parts.

Large Shock "N" → "R" Position

INFOID:000000005928251

SYMPTOM:

There is a large shock when changing from "N" to "R" position.

DIAGNOSTIC PROCEDURE

1. CHECK SELF-DIAGNOSTIC RESULTS

Perform self-diagnosis. Refer to [AT-77, "CONSULT-III Function \(TRANSMISSION\)"](#) or [AT-82, "Diagnosis Procedure without CONSULT-III"](#) .

Is any malfunction detected by self-diagnostic results?

- YES >> Check the malfunctioning system. Refer to [AT-77, "CONSULT-III Function \(TRANSMISSION\)"](#) or [AT-82, "Diagnosis Procedure without CONSULT-III"](#) .
- NO >> GO TO 2.

2. CHECK LINE PRESSURE

Check line pressure at idle with selector lever in "D" position. Refer to [AT-51, "Inspections Before Trouble Diagnosis"](#) .

OK or NG

- OK >> GO TO 4.
- NG >> GO TO 3.

3. DETECT MALFUNCTIONING ITEM

1. Remove control valve assembly. Refer to [AT-222, "Control Valve Assembly and Accumulators"](#) .
2. Check the following items:
 - Valves to control line pressure (Pressure regulator valve, pressure modifier valve, pilot valve and pilot filter)
 - Line pressure solenoid valve
 - Oil pump assembly. Refer to [AT-278, "Oil Pump"](#) .

OK or NG

TROUBLE DIAGNOSIS FOR SYMPTOMS

< SERVICE INFORMATION >

- OK >> GO TO 4.
NG >> Repair or replace damaged parts.

4.CHECK SYMPTOM

Check again. Refer to [AT-56. "Check at Idle"](#) .

OK or NG

- OK >> **INSPECTION END**
NG >> GO TO 5.

5.CHECK TCM

1. Check TCM input/output signals. Refer to [AT-75. "TCM Terminal and Reference Value"](#) .
2. If NG, recheck TCM pin terminals for damage or loose connection with harness connector.

OK or NG

- OK >> **INSPECTION END**
NG >> Repair or replace damaged parts.

Vehicle Does Not Creep Backward in "R" Position

INFOID:000000005928252

SYMPTOM:

Vehicle does not creep backward when selecting "R" position.

DIAGNOSTIC PROCEDURE

1.CHECK A/T FLUID LEVEL

Check A/T fluid level. Refer to [AT-17. "Checking A/T Fluid"](#) .

OK or NG

- OK >> GO TO 2.
NG >> Refill ATF.

2.CHECK LINE PRESSURE

Check line pressure at idle with selector lever in "R" position. Refer to [AT-51. "Inspections Before Trouble Diagnosis"](#) .

OK or NG

- OK >> GO TO 4.
NG >> GO TO 3.

3.DETECT MALFUNCTIONING ITEM

1. Remove control valve assembly. Refer to [AT-222. "Control Valve Assembly and Accumulators"](#) .
2. Check the following items:
 - Valves to control line pressure (Pressure regulator valve, pressure modifier valve, pilot valve and pilot filter)
 - Line pressure solenoid valve
3. Disassemble A/T. Refer to [AT-257. "Disassembly"](#) .
4. Check the following item:
 - Oil pump assembly. Refer to [AT-278. "Oil Pump"](#) .

OK or NG

- OK >> GO TO 4.
NG >> Repair or replace damaged parts.

4.CHECK STALL REVOLUTION

Check stall revolution with selector lever in "1" and "R" positions. Refer to [AT-51. "Inspections Before Trouble Diagnosis"](#) .

OK or NG

- OK >> GO TO 6.
OK in "1" position, NG in "R" position>>GO TO 5.
NG in both "1" and "R" positions>>GO TO 7.

5.DETECT MALFUNCTIONING ITEM

TROUBLE DIAGNOSIS FOR SYMPTOMS

< SERVICE INFORMATION >

1. Disassemble A/T. Refer to [AT-257, "Disassembly"](#) .
2. Check the following items:
 - Low & reverse brake assembly. Refer to [AT-314, "Low & Reverse Brake"](#) .
 - Reverse clutch assembly. Refer to [AT-297, "Reverse Clutch"](#) .

OK or NG

- OK >> GO TO 6.
NG >> Repair or replace damaged parts.

6.CHECK A/T FLUID CONDITION

1. Remove oil pan. Refer to [AT-237, "Component"](#) .
2. Check A/T fluid condition. Refer to [AT-51, "Inspections Before Trouble Diagnosis"](#) .

OK or NG

- OK >> GO TO 8.
NG >> GO TO 7.

7.DETECT MALFUNCTIONING ITEM

1. Disassemble A/T. Refer to [AT-257, "Disassembly"](#) .
2. Check the following items:
 - Reverse clutch assembly. Refer to [AT-297, "Reverse Clutch"](#) .
 - High clutch assembly. Refer to [AT-302, "High Clutch"](#) .
 - Low & reverse brake assembly. Refer to [AT-314, "Low & Reverse Brake"](#) .
 - Forward clutch assembly. Refer to [AT-307, "Forward and Overrun Clutches"](#) .
 - Overrun clutch assembly. Refer to [AT-307, "Forward and Overrun Clutches"](#) .

OK or NG

- OK >> GO TO 8.
NG >> Repair or replace damaged parts.

8.CHECK SYMPTOM

Check again. Refer to [AT-56, "Check at Idle"](#) .

OK or NG

- OK >> **INSPECTION END**
NG >> GO TO 9.

9.CHECK TCM

1. Check TCM input/output signals. Refer to [AT-75, "TCM Terminal and Reference Value"](#) .
2. If NG, recheck TCM pin terminals for damage or loose connection with harness connector.

OK or NG

- OK >> **INSPECTION END**
NG >> Repair or replace damaged parts.

Vehicle Does Not Creep Forward in "D", "2" or "1" Position

INFOID:000000005928253

SYMPTOM:

Vehicle does not creep forward when selecting "D", "2" or "1" position.

DIAGNOSTIC PROCEDURE

1.CHECK A/T FLUID LEVEL

Check A/T fluid level. Refer to [AT-17, "Checking A/T Fluid"](#) .

OK or NG

- OK >> GO TO 2.
NG >> Refill ATF.

2.CHECK LINE PRESSURE

Check line pressure at idle with selector lever in "D" position. Refer to [AT-51, "Inspections Before Trouble Diagnosis"](#) .

OK or NG

- OK >> GO TO 4.

TROUBLE DIAGNOSIS FOR SYMPTOMS

< SERVICE INFORMATION >

NG >> GO TO 3.

3. DETECT MALFUNCTIONING ITEM

1. Remove control valve assembly. Refer to [AT-222, "Control Valve Assembly and Accumulators"](#).
2. Check the following items:
 - Valves to control line pressure (Pressure regulator valve, pressure modifier valve, pilot valve and pilot filter)
 - Line pressure solenoid valve
3. Disassemble A/T. Refer to [AT-257, "Disassembly"](#).
4. Check the following item:
 - Oil pump assembly. Refer to [AT-278, "Oil Pump"](#).

OK or NG

OK >> GO TO 4.

NG >> Repair or replace damaged parts.

4. CHECK STALL REVOLUTION

Check stall revolution with selector lever in "D" position. Refer to [AT-51, "Inspections Before Trouble Diagnosis"](#).

OK or NG

OK >> GO TO 6.

NG >> GO TO 5.

5. DETECT MALFUNCTIONING ITEM

1. Disassemble A/T. Refer to [AT-257, "Disassembly"](#).
2. Check the following items:
 - Oil pump assembly. Refer to [AT-278, "Oil Pump"](#).
 - Forward clutch assembly. Refer to [AT-307, "Forward and Overrun Clutches"](#).
 - Forward one-way clutch. Refer to [AT-318, "Rear Internal Gear and Forward Clutch Hub"](#).
 - Low one-way clutch. Refer to [AT-257, "Disassembly"](#).
 - Torque converter. Refer to [AT-257, "Disassembly"](#).

OK or NG

OK >> GO TO 7.

NG >> Repair or replace damaged parts.

6. CHECK A/T FLUID CONDITION

1. Remove oil pan. Refer to [AT-237, "Component"](#).
2. Check A/T fluid condition. Refer to [AT-51, "Inspections Before Trouble Diagnosis"](#).

OK or NG

OK >> GO TO 7.

NG >> GO TO 5.

7. CHECK SYMPTOM

Check again. Refer to [AT-56, "Check at Idle"](#).

OK or NG

OK >> **INSPECTION END**

NG >> GO TO 8.

8. CHECK TCM

1. Check TCM input/output signals. Refer to [AT-75, "TCM Terminal and Reference Value"](#).
2. If NG, recheck TCM pin terminals for damage or loose connection with harness connector.

OK or NG

OK >> **INSPECTION END**

NG >> Repair or replace damaged parts.

Vehicle Cannot Be Started from D1

INFOID:000000005928254

SYMPTOM:

Vehicle cannot be started from D1 on "Cruise Test — Part 1".

TROUBLE DIAGNOSIS FOR SYMPTOMS

< SERVICE INFORMATION >

DIAGNOSTIC PROCEDURE

1. CHECK SYMPTOM

Check symptom. Refer to [AT-56, "Check at Idle"](#) .

Is "Vehicle Dose Not Creep Backward in "R" Position" OK?

OK >> GO TO 2.

NG >> Go to [AT-185, "Vehicle Does Not Creep Backward in "R" Position"](#) .

2. CHECK SELF-DIAGNOSTIC RESULTS

Perform self-diagnosis. Refer to [AT-77, "CONSULT-III Function \(TRANSMISSION\)"](#) or [AT-82, "Diagnosis Procedure without CONSULT-III"](#) .

Is any malfunction detected by self-diagnostic results?

YES >> Check the malfunctioning system. Refer to [AT-77, "CONSULT-III Function \(TRANSMISSION\)"](#) or [AT-82, "Diagnosis Procedure without CONSULT-III"](#) .

NO >> GO TO 3.

3. CHECK ACCELERATOR PEDAL POSITION SENSOR

Check accelerator pedal position sensor. Refer to [EC-415, "Description"](#) (HR16DE), [EC-982, "Component Description"](#) (MR18DE).

OK or NG

OK >> GO TO 4.

NG >> Repair or replace accelerator pedal position sensor.

4. CHECK LINE PRESSURE

Check line pressure at stall point with selector lever in "D" position. Refer to [AT-51, "Inspections Before Trouble Diagnosis"](#) .

OK or NG

OK >> GO TO 6.

NG >> GO TO 5.

5. DETECT MALFUNCTIONING ITEM

1. Remove control valve assembly. Refer to [AT-222, "Control Valve Assembly and Accumulators"](#) .

2. Check the following items:

- Shift valve A
- Shift valve B
- Shift solenoid valve A
- Shift solenoid valve B
- Pilot valve
- Pilot filter

3. Disassemble A/T. Refer to [AT-257, "Disassembly"](#) .

4. Check the following items:

- Forward clutch assembly. Refer to [AT-307, "Forward and Overrun Clutches"](#) .
- Low one-way clutch. Refer to [AT-257, "Disassembly"](#) .
- Forward one-way clutch. Refer to [AT-318, "Rear Internal Gear and Forward Clutch Hub"](#) .
- High clutch assembly. Refer to [AT-302, "High Clutch"](#) .
- Torque converter. Refer to [AT-257, "Disassembly"](#) .
- Oil pump assembly. Refer to [AT-278, "Oil Pump"](#) .

OK or NG

OK >> GO TO 8.

NG >> Repair or replace damaged parts.

6. CHECK A/T FLUID CONDITION

1. Remove oil pan. Refer to [AT-237, "Component"](#) .

2. Check A/T fluid condition. Refer to [AT-51, "Inspections Before Trouble Diagnosis"](#) .

OK or NG

OK >> GO TO 7.

NG >> GO TO 5.

TROUBLE DIAGNOSIS FOR SYMPTOMS

< SERVICE INFORMATION >

7. DETECT MALFUNCTIONING ITEM

1. Remove control valve assembly. Refer to [AT-222, "Control Valve Assembly and Accumulators"](#) .
2. Check the following items:
 - Shift valve A
 - Shift valve B
 - Shift solenoid valve A
 - Shift solenoid valve B
 - Pilot valve
 - Pilot filter

OK or NG

- OK >> GO TO 8.
NG >> Repair or replace damage parts.

8. CHECK SYMPTOM

Check again. Refer to [AT-58, "Cruise Test - Part 1"](#) .

OK or NG

- OK >> **INSPECTION END**
NG >> GO TO 9.

9. CHECK TCM

1. Check TCM input/output signals. Refer to [AT-75, "TCM Terminal and Reference Value"](#) .
2. If NG, recheck TCM pin terminals for damage or loose connection with harness connector.

OK or NG

- OK >> **INSPECTION END**
NG >> Repair or replace damaged parts.

A/T Does Not Shift: D1→ D2or Does Not Kickdown: D4→ D2

INFOID:000000005928255

SYMPTOM:

- A/T does not shift from D1 to D2 at the specified speed on "Cruise Test — Part 1".
- A/T does not shift from D4 to D2 when depressing accelerator pedal fully at the specified speed on "Cruise Test — Part 2".

DIAGNOSTIC PROCEDURE

1. CHECK SYMPTOM

Check symptom . Refer to [AT-56, "Check at Idle"](#) and [AT-58, "Cruise Test - Part 1"](#) .

Are "Vehicle Dose Not Creep Forward in "D", "2" or "1" Position" and "Vehicle Cannot Be Started from D1" OK?

- YES >> GO TO 2.
NO >> Go to [AT-186, "Vehicle Does Not Creep Forward in "D", "2" or "1" Position"](#) and [AT-187, "Vehicle Cannot Be Started from D1"](#) .

2. CHECK A/T POSITION

Check A/T position. Refer to [AT-217, "Checking of A/T Position"](#) .

OK or NG

- OK >> GO TO 3.
NG >> Adjust A/T position. Refer to [AT-217, "Adjustment of A/T Position"](#) .

3. CHECK OUTPUT SPEED SENSOR AND VEHICLE SPEED SIGNAL CIRCUIT

Check output speed sensor and vehicle speed signal circuit. Refer to [AT-100](#) and [AT-153](#) .

OK or NG

- OK >> GO TO 4.
NG >> Repair or replace output speed sensor and vehicle speed signal circuits.

4. CHECK ACCELERATOR PEDAL POSITION SENSOR

Check accelerator pedal position sensor. Refer to [EC-415, "Description"](#) (HR16DE), [EC-982, "Component Description"](#) (MR18DE).

TROUBLE DIAGNOSIS FOR SYMPTOMS

< SERVICE INFORMATION >

OK or NG

- OK >> GO TO 5.
- NG >> Repair or replace accelerator pedal position sensor.

5. CHECK A/T FLUID CONDITION

1. Remove oil pan. Refer to [AT-237, "Component"](#).
2. Check A/T fluid condition. Refer to [AT-51, "Inspections Before Trouble Diagnosis"](#).

OK or NG

- OK >> GO TO 7.
- NG >> GO TO 6.

6. DETECT MALFUNCTIONING ITEM

1. Remove control valve. Refer to [AT-222, "Control Valve Assembly and Accumulators"](#).
2. Check the following items:
 - Shift valve A
 - Shift valve B
 - Shift solenoid valve A
 - Shift solenoid valve B
 - Pilot valve
 - Pilot filter
3. Disassemble A/T. Refer to [AT-257, "Disassembly"](#).
4. Check the following items:
 - Servo piston assembly
 - Brake band

OK or NG

- OK >> GO TO 8.
- NG >> Repair or replace damaged parts.

7. DETECT MALFUNCTIONING ITEM

1. Remove control valve. Refer to [AT-222, "Control Valve Assembly and Accumulators"](#).
2. Check the following items:
 - Shift valve A
 - Shift valve B
 - Shift solenoid valve A
 - Shift solenoid valve B
 - Pilot valve
 - Pilot filter

OK or NG

- OK >> GO TO 8.
- NG >> Repair or replace damaged parts.

8. CHECK SYMPTOM

Check again. Refer to [AT-58, "Cruise Test - Part 1"](#) and [AT-61, "Cruise Test - Part 2"](#).

OK or NG

- OK >> **INSPECTION END**
- NG >> GO TO 9.

9. CHECK TCM

1. Check TCM input/output signals. Refer to [AT-75, "TCM Terminal and Reference Value"](#).
2. If NG, recheck TCM pin terminals for damage or loose connection with harness connector.

OK or NG

- OK >> **INSPECTION END**
- NG >> Repair or replace damaged parts.

A/T Does Not Shift: D2→ D3

INFOID:000000005928256

SYMPTOM:

TROUBLE DIAGNOSIS FOR SYMPTOMS

< SERVICE INFORMATION >

A/T does not shift from D2 to D3 at the specified speed on “Cruise Test — Part 1” and “Cruise Test — Part 2”.

DIAGNOSTIC PROCEDURE

1. CHECK SYMPTOM

Check symptom. Refer to [AT-56, "Check at Idle"](#) and [AT-58, "Cruise Test - Part 1"](#).

Are “Vehicle Does Not Creep Forward in “D”, “2” or “1” Position” and “Vehicle Cannot Be Started from D1” OK?

YES >> GO TO 2.

NO >> Go to [AT-186, "Vehicle Does Not Creep Forward in "D", "2" or "1" Position"](#) and [AT-187, "Vehicle Cannot Be Started from D1"](#).

2. CHECK A/T POSITION

Check A/T position. Refer to [AT-217, "Checking of A/T Position"](#).

OK or NG

OK >> GO TO 3.

NG >> Adjust A/T position. Refer to [AT-217, "Adjustment of A/T Position"](#).

3. CHECK OUTPUT SPEED SENSOR AND VEHICLE SPEED SIGNAL CIRCUIT

Check output speed sensor and vehicle speed signal circuit. Refer to [AT-100](#) and [AT-153](#).

OK or NG

OK >> GO TO 4.

NG >> Repair or replace output speed sensor and vehicle speed signal circuits.

4. CHECK ACCELERATOR PEDAL POSITION SENSOR

Check accelerator pedal position sensor. Refer to [EC-415, "Description"](#) (HR16DE), [EC-982, "Component Description"](#) (MR18DE).

OK or NG

OK >> GO TO 5.

NG >> Repair or replace accelerator pedal position sensor.

5. CHECK A/T FLUID CONDITION

1. Remove oil pan. Refer to [AT-237, "Component"](#).

2. Check A/T fluid condition. Refer to [AT-51, "Inspections Before Trouble Diagnosis"](#).

OK or NG

OK >> GO TO 7.

NG >> GO TO 6.

6. DETECT MALFUNCTIONING ITEM

1. Remove control valve assembly. Refer to [AT-222, "Control Valve Assembly and Accumulators"](#).

2. Check the following items:

- Shift valve B
- Shift solenoid valve B
- Pilot valve
- Pilot filter

3. Disassemble A/T. Refer to [AT-257, "Disassembly"](#).

4. Check the following items:

- Servo piston assembly
- High clutch assembly. Refer to [AT-302, "High Clutch"](#).
- Oil pump assembly. Refer to [AT-278, "Oil Pump"](#).

OK or NG

OK >> GO TO 8.

NG >> Repair or replace damaged parts.

7. DETECT MALFUNCTIONING ITEM

1. Remove control valve assembly. Refer to [AT-222, "Control Valve Assembly and Accumulators"](#).

2. Check the following items:

- Shift valve B

TROUBLE DIAGNOSIS FOR SYMPTOMS

< SERVICE INFORMATION >

- Shift solenoid valve B
- Pilot valve
- Pilot filter

OK or NG

- OK >> GO TO 8.
NG >> Repair or replace damaged parts.

8.CHECK SYMPTOM

Check again. Refer to [AT-58, "Cruise Test - Part 1"](#) and [AT-61, "Cruise Test - Part 2"](#).

OK or NG

- OK >> **INSPECTION END**
NG >> GO TO 9.

9.CHECK TCM

1. Check TCM input/output signal. Refer to [AT-75, "TCM Terminal and Reference Value"](#).
2. If NG, recheck TCM pin terminals for damage or loose connection with harness connector.

OK or NG

- OK >> **INSPECTION END**
NG >> Repair or replace damaged parts.

A/T Does Not Shift: D3→D4

INFOID:000000005928257

SYMPTOM:

- A/T does not shift from D3 to D4 at the specified speed on "Cruise Test — Part 1" and "Cruise Test — Part 2".
- A/T must be warm before D3 to D4 shift will occur.

DIAGNOSTIC PROCEDURE

1.CHECK SYMPTOM

Check symptom. Refer to [AT-56, "Check at Idle"](#) and [AT-58, "Cruise Test - Part 1"](#).

Are "Vehicle Does Not Creep Forward in "D", "2" or "1" Position" and "Vehicle Cannot Be Started from D1" OK?

- YES >> GO TO 2.
NO >> Go to [AT-186, "Vehicle Does Not Creep Forward in "D", "2" or "1" Position"](#) and [AT-187, "Vehicle Cannot Be Started from D1"](#).

2.CHECK SELF-DIAGNOSTIC RESULTS

Perform self-diagnosis. Refer to [AT-77, "CONSULT-III Function \(TRANSMISSION\)"](#) or [AT-82, "Diagnosis Procedure without CONSULT-III"](#).

Is any malfunction detected by self-diagnostic results?

- YES >> Check the malfunctioning system. Refer to [AT-77, "CONSULT-III Function \(TRANSMISSION\)"](#) or [AT-82, "Diagnosis Procedure without CONSULT-III"](#).
NO >> GO TO 3.

3.CHECK ACCELERATOR PEDAL POSITION SENSOR

Check accelerator pedal position sensor. Refer to [EC-415, "Description"](#) (HR16DE), [EC-982, "Component Description"](#) (MR18DE).

OK or NG

- OK >> GO TO 4.
NG >> Repair or replace accelerator pedal position sensor.

4.CHECK A/T FLUID CONDITION

1. Remove oil pan. Refer to [AT-237, "Component"](#).
2. Check A/T fluid condition. Refer to [AT-51, "Inspections Before Trouble Diagnosis"](#).

OK or NG

- OK >> GO TO 6.
NG >> GO TO 5.

TROUBLE DIAGNOSIS FOR SYMPTOMS

< SERVICE INFORMATION >

5. DETECT MALFUNCTIONING ITEM

1. Remove control valve assembly. Refer to [AT-222, "Control Valve Assembly and Accumulators"](#).
2. Check the following items:
 - Shift valve A
 - Overrun clutch control valve
 - Shift solenoid valve A
 - Overrun clutch solenoid valve
 - Pilot valve
 - Pilot filter
3. Disassemble A/T. Refer to [AT-257, "Disassembly"](#).
4. Check the following items:
 - Servo piston assembly
 - Brake band
 - Torque converter. Refer to [AT-257, "Disassembly"](#).
 - Oil pump assembly. Refer to [AT-278, "Oil Pump"](#).

OK or NG

- OK >> GO TO 7.
NG >> Repair or replace damaged parts.

6. DETECT MALFUNCTIONING ITEM

1. Remove control valve assembly. Refer to [AT-222, "Control Valve Assembly and Accumulators"](#).
2. Check the following items:
 - Shift valve A
 - Overrun clutch control valve
 - Shift solenoid valve A
 - Pilot valve
 - Pilot filter

OK or NG

- OK >> GO TO 7.
NG >> Repair or replace damaged parts.

7. CHECK SYMPTOM

Check again. Refer to [AT-58, "Cruise Test - Part 1"](#) and [AT-61, "Cruise Test - Part 2"](#).

OK or NG

- OK >> **INSPECTION END**
NG >> GO TO 8.

8. CHECK TCM

1. Check TCM input/output signals. Refer to [AT-75, "TCM Terminal and Reference Value"](#).
2. If NG, recheck TCM pin terminals for damage or loose connection with harness connector.

OK or NG

- OK >> **INSPECTION END**
NG >> Repair or replace damaged parts.

A/T Does Not Perform Lock-up

INFOID:000000005928258

SYMPTOM:

A/T does not perform lock-up at the specified speed on "Cruise Test — Part 1".

DIAGNOSTIC PROCEDURE

1. CHECK SELF-DIAGNOSTIC RESULTS

Perform self-diagnosis. Refer to [AT-77, "CONSULT-III Function \(TRANSMISSION\)"](#) or [AT-82, "Diagnosis Procedure without CONSULT-III"](#).

Is any malfunction detected by self-diagnostic results?

- YES >> Check the malfunctioning system. Refer to [AT-77, "CONSULT-III Function \(TRANSMISSION\)"](#) or [AT-82, "Diagnosis Procedure without CONSULT-III"](#).
NO >> GO TO 2.

TROUBLE DIAGNOSIS FOR SYMPTOMS

< SERVICE INFORMATION >

2. CHECK ACCELERATOR PEDAL POSITION SENSOR

Check accelerator pedal position sensor. Refer to [EC-415. "Description"](#) (HR16DE), [EC-982. "Component Description"](#) (MR18DE).

OK or NG

- OK >> GO TO 3.
- NG >> Repair or replace accelerator pedal position sensor.

3. DETECT MALFUNCTIONING ITEM

1. Remove control valve. Refer to [AT-222. "Control Valve Assembly and Accumulators"](#).
2. Check following items:
 - Torque converter clutch control valve
 - Torque converter clutch solenoid valve
 - Torque converter relief valve
 - Pilot valve
 - Pilot filter
3. Disassemble A/T. Refer to [AT-257. "Disassembly"](#).
4. Check the following items:
 - Torque converter. Refer to [AT-257. "Disassembly"](#).

OK or NG

- OK >> GO TO 4.
- NG >> Repair or replace damaged parts.

4. CHECK SYMPTOM

Check again. Refer to [AT-58. "Cruise Test - Part 1"](#).

OK or NG

- OK >> **INSPECTION END**
- NG >> GO TO 5.

5. CHECK TCM

1. Check TCM input/output signals. Refer to [AT-75. "TCM Terminal and Reference Value"](#).
2. If NG, recheck TCM pin terminals for damage or loose connection with harness connector.

OK or NG

- OK >> **INSPECTION END**
- NG >> Repair or replace damaged parts.

A/T Does Not Hold Lock-up Condition

INFOID:000000005928259

SYMPTOM:

A/T does not hold lock-up condition for more than 30 seconds on "Cruise Test — Part 1".

DIAGNOSTIC PROCEDURE

1. CHECK SELF-DIAGNOSTIC RESULTS

Perform self-diagnosis. Refer to [AT-77. "CONSULT-III Function \(TRANSMISSION\)"](#) or [AT-82. "Diagnosis Procedure without CONSULT-III"](#).

Is any malfunction detected by self-diagnostic results?

- YES >> Check the malfunctioning system. Refer to [AT-77. "CONSULT-III Function \(TRANSMISSION\)"](#) or [AT-82. "Diagnosis Procedure without CONSULT-III"](#).
- NO >> GO TO 2.

2. CHECK A/T FLUID CONDITION

1. Remove oil pan. Refer to [AT-237. "Component"](#).
2. Check A/T fluid condition. Refer to [AT-51. "Inspections Before Trouble Diagnosis"](#).

OK or NG

- OK >> GO TO 4.
- NG >> GO TO 3.

TROUBLE DIAGNOSIS FOR SYMPTOMS

< SERVICE INFORMATION >

3. DETECT MALFUNCTIONING ITEM

1. Remove control valve assembly. Refer to [AT-222, "Control Valve Assembly and Accumulators"](#) .
2. Check the following items:
 - Torque converter clutch control valve
 - Torque converter clutch solenoid valve
 - Pilot valve
 - Pilot filter
3. Disassemble A/T. Refer to [AT-257, "Disassembly"](#) .
4. Check the following items:
 - Torque converter. Refer to [AT-257, "Disassembly"](#) .
 - Oil pump assembly. Refer to [AT-278, "Oil Pump"](#) .

OK or NG

- OK >> GO TO 5.
- NG >> Repair or replace damaged parts.

4. DETECT MALFUNCTIONING ITEM

1. Remove control valve assembly. Refer to [AT-222, "Control Valve Assembly and Accumulators"](#) .
2. Check the following items:
 - Torque converter clutch control valve
 - Torque converter clutch solenoid valve
 - Pilot valve
 - Pilot filter

OK or NG

- OK >> GO TO 5.
- NG >> Repair or replace damaged parts.

5. CHECK SYMPTOM

Check again. Refer to [AT-58, "Cruise Test - Part 1"](#) .

OK or NG

- OK >> **INSPECTION END**
- NG >> GO TO 6.

6. CHECK TCM

1. Check TCM input/output signals. Refer to [AT-75, "TCM Terminal and Reference Value"](#) .
2. If NG, recheck TCM pin terminals for damage or loose connection with harness connector.

OK or NG

- OK >> **INSPECTION END**
- NG >> Repair or replace damaged parts.

Lock-up Is Not Released

INFOID:000000005928260

SYMPTOM:

Lock-up is not released when accelerator pedal is released on "Cruise Test — Part 1".

DIAGNOSTIC PROCEDURE

1. CHECK SELF-DIAGNOSTIC RESULTS

Perform self-diagnosis. Refer to [AT-77, "CONSULT-III Function \(TRANSMISSION\)"](#) or [AT-82, "Diagnosis Procedure without CONSULT-III"](#) .

Is any malfunction detected by self-diagnostic results?

- YES >> Check the malfunctioning system. Refer to [AT-77, "CONSULT-III Function \(TRANSMISSION\)"](#) or [AT-82, "Diagnosis Procedure without CONSULT-III"](#) .
- NO >> GO TO 2.

2. CHECK SYMPTOM

Check again. Refer to [AT-58, "Cruise Test - Part 1"](#) .

OK or NG

TROUBLE DIAGNOSIS FOR SYMPTOMS

< SERVICE INFORMATION >

- OK >> **INSPECTION END**
NG >> GO TO 3.

3.CHECK TCM

1. Check TCM input/output signals. Refer to [AT-75, "TCM Terminal and Reference Value"](#) .
2. If NG, recheck TCM pin terminals for damage or loose connection with harness connector.

OK or NG

- OK >> **INSPECTION END**
NG >> Repair or replace damaged parts.

Engine Speed Does Not Return to Idle (Light Braking D4→ D3)

INFOID:000000005928261

SYMPTOM:

Engine speed does not smoothly return to idle when A/T shifts from D4 to D3 on "Cruise Test — Part 1".

DIAGNOSTIC PROCEDURE

1.CHECK SELF-DIAGNOSTIC RESULTS

Perform self-diagnosis. Refer to [AT-77, "CONSULT-III Function \(TRANSMISSION\)"](#) or [AT-82, "Diagnosis Procedure without CONSULT-III"](#) .

Is any malfunction detected by self-diagnostic results?

- YES >> Check the malfunctioning system. Refer to [AT-77, "CONSULT-III Function \(TRANSMISSION\)"](#) or [AT-82, "Diagnosis Procedure without CONSULT-III"](#) .
NO >> GO TO 2.

2.CHECK ACCELERATOR PEDAL POSITION SENSOR

Check accelerator pedal position sensor. Refer to [EC-415, "Description"](#) (HR16DE), [EC-982, "Component Description"](#) (MR18DE).

OK or NG

- OK >> GO TO 3.
NG >> Repair or replace accelerator pedal position sensor.

3.CHECK A/T FLUID CONDITION

1. Remove oil pan. Refer to [AT-237, "Component"](#) .
2. Check A/T fluid condition. Refer to [AT-51, "Inspections Before Trouble Diagnosis"](#) .

OK or NG

- OK >> GO TO 5.
NG >> GO TO 4.

4.DETECT MALFUNCTIONING ITEM

1. Remove control valve assembly. Refer to [AT-222, "Control Valve Assembly and Accumulators"](#) .
2. Check the following items:
 - Overrun clutch control valve
 - Overrun clutch reducing valve
 - Overrun clutch solenoid valve
3. Disassemble A/T. Refer to [AT-257, "Disassembly"](#) .
4. Check the following items:
 - Overrun clutch assembly. Refer to [AT-307, "Forward and Overrun Clutches"](#) .

OK or NG

- OK >> GO TO 6.
NG >> Repair or replace damaged parts.

5.DETECT MALFUNCTIONING ITEM

1. Remove control valve assembly. Refer to [AT-222, "Control Valve Assembly and Accumulators"](#) .
2. Check the following items:
 - Overrun clutch control valve
 - Overrun clutch reducing valve
 - Overrun clutch solenoid valve

TROUBLE DIAGNOSIS FOR SYMPTOMS

< SERVICE INFORMATION >

OK or NG

- OK >> GO TO 6.
- NG >> Repair or replace damaged parts.

6. CHECK SYMPTOM

Check again. Refer to [AT-58, "Cruise Test - Part 1"](#).

OK or NG

- OK >> **INSPECTION END**
- NG >> GO TO 7.

7. CHECK TCM

1. Check TCM input/output signals. Refer to [AT-75, "TCM Terminal and Reference Value"](#).
2. If NG, recheck TCM pin terminals for damage or loose connection with harness connector.

OK or NG

- OK >> **INSPECTION END**
- NG >> Repair or replace damaged parts.

A/T Does Not Shift: D4 → D3, When OD OFF

INFOID:000000005928262

SYMPTOM:

A/T does not shift from D4 to D3 when OD OFF (OD OFF indicator lamp is on) on "Cruise Test — Part 3".

DIAGNOSTIC PROCEDURE

1. CHECK CAN COMMUNICATION LINE

Perform self-diagnosis. Refer to [AT-77, "CONSULT-III Function \(TRANSMISSION\)"](#) or [AT-82, "Diagnosis Procedure without CONSULT-III"](#).

Is a malfunction in CAN communication indicated in the results?

- YES >> Check CAN communication line. Refer to [AT-87](#).
- NO >> GO TO 2.

2. CHECK OVERDRIVE CONTROL SWITCH CIRCUIT

☑ With CONSULT-III

1. Turn ignition switch ON. (Do not start engine)
2. Select "TCM INPUT SIGNALS" in "DATA MONITOR" mode for "TRANSMISSION" with CONSULT-III.
3. Read out "OVERDRIVE SW".
Check the signal of the overdrive control switch is indicated properly.

Item name	Overdrive control switch Condition	Display value
OVERDRIVE SW	Depressed	ON
	Released	OFF

☒ Without CONSULT-III

1. Turn ignition switch ON. (Do not start engine)
2. Check voltage between A/T shift selector harness connector terminal and ground. Refer to [AT-177, "Wiring Diagram - AT - NON-DTC"](#).

Item	Connector	Terminal	Overdrive control switch Condition	Judgment standard (Approx.)
A/T shift selector harness connector (Overdrive control switch)	M38	1 - Ground	Released	Battery voltage
			Depressed	0V

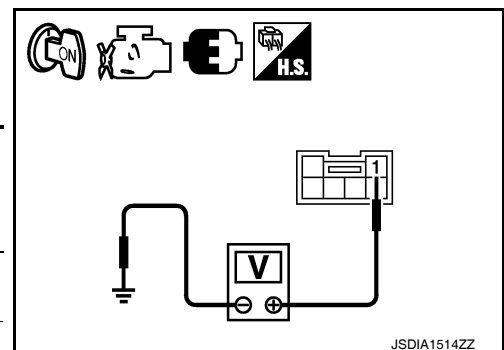

TROUBLE DIAGNOSIS FOR SYMPTOMS

< SERVICE INFORMATION >

OK or NG

- OK >> Go to [AT-190, "A/T Does Not Shift: D₂→D₃"](#) .
- NG >> Check overdrive control switch. Refer to [AT-175, "Component Inspection"](#) .

A/T Does Not Shift: D₃→2₂, When Selector Lever "D" → "2" Position

INFOID:000000005928263

SYMPTOM:

A/T does not shift from D₃ to 2₂ when changing selector lever from "D" to "2" position on "Cruise Test — Part 3".

DIAGNOSTIC PROCEDURE

1. CHECK SYMPTOM

Check symptom. Refer to [AT-58, "Cruise Test - Part 1"](#) or [AT-61, "Cruise Test - Part 2"](#) .

Is "A/T Does Not Shift: D₁→D₂ or Does Not Kickdown: D₄→D₂" OK?

- YES (With CONSULT-III) >>GO TO 2.
- YES (Without CONSULT-III) >>GO TO 3.
- NO >> Go to [AT-189, "A/T Does Not Shift: D₁→D₂ or Does Not Kickdown: D₄→D₂"](#) .

2. CHECK TRANSMISSION RANGE SWITCH CIRCUIT

 **With CONSULT-III**

1. Turn ignition switch ON. (Do not start engine.)
2. Select "TCM INPUT SIGNALS" in "DATA MONITOR" mode for "TRANSMISSION" with CONSULT-III.
3. Read out "P·N", "R", "D", "2" and "1" position switches moving selector lever to each position.

Monitor item	Condition	Display value
PN POSI SW	When setting selector lever to "N" or "P" position.	ON
	When setting selector lever to other positions.	OFF
R POSITION SW	When setting selector lever to "R" position.	ON
	When setting selector lever to other positions.	OFF
D POSITION SW	When setting selector lever to "D" positions.	ON
	When setting selector lever to other positions.	OFF
2 POSITION SW	When setting selector lever to "2" position.	ON
	When setting selector lever to other positions.	OFF
1 POSITION SW	When setting selector lever to "1" position.	ON
	When setting selector lever to other positions.	OFF

OK or NG

- OK >> **INSPECTION END**
- NG >> Check transmission range switch. Refer to [AT-175, "Component Inspection"](#) .

3. CHECK TRANSMISSION RANGE SWITCH CIRCUIT

 **Without CONSULT-III**

1. Turn ignition switch ON. (Do not start engine.)

TROUBLE DIAGNOSIS FOR SYMPTOMS

< SERVICE INFORMATION >

- Check voltage between TCM connector terminals and ground while moving selector lever through each position. Refer to [AT-91. "Wiring Diagram - AT - TR/SW"](#).

Selector lever position	Terminal				
	36	35	34	27	26
"P", "N"	B	0	0	0	0
"R"	0	B	0	0	0
"D"	0	0	B	0	0
"2"	0	0	0	B	0
"1"	0	0	0	0	B

B: Battery voltage

0: 0V

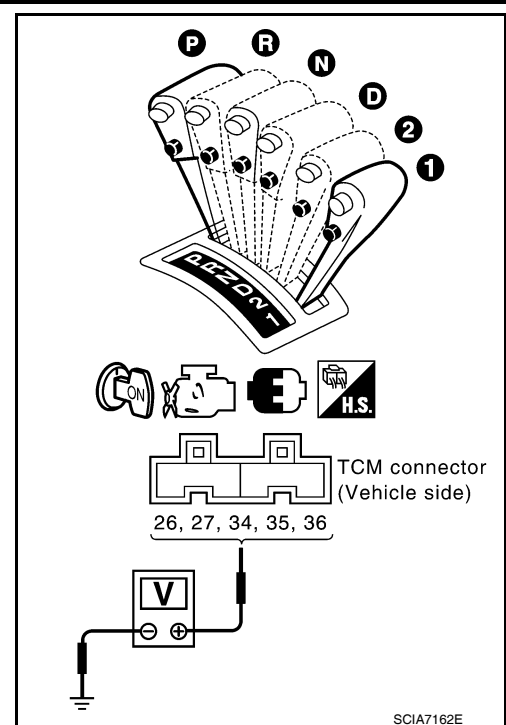

OK or NG

OK >> **INSPECTION END**

NG >> Check transmission range switch. Refer to [AT-175. "Component Inspection"](#).

A/T Does Not Shift: 22 → 11, When Selector Lever "2" → "1" Position

INFOID:0000000005928264

SYMPTOM:

A/T does not shift from 22 to 11 when changing selector lever from "2" to "1" position on "Cruise Test — Part 3".

DIAGNOSTIC PROCEDURE

1. CHECK TRANSMISSION RANGE SWITCH CIRCUIT

With CONSULT-III

- Turn ignition switch ON. (Do not start engine.)
- Select "TCM INPUT SIGNALS" in "DATA MONITOR" mode for "TRANSMISSION" with CONSULT-III.
- Read out "P-N", "R", "D", "2" and "1" position switches moving selector lever to each position.

Monitor item	Condition	Display value
PN POSI SW	When setting selector lever to "N" or "P" position.	ON
	When setting selector lever to other positions.	OFF
R POSITION SW	When setting selector lever to "R" position.	ON
	When setting selector lever to other positions.	OFF
D POSITION SW	When setting selector lever to "D" positions.	ON
	When setting selector lever to other positions.	OFF
2 POSITION SW	When setting selector lever to "2" position.	ON
	When setting selector lever to other positions.	OFF
1 POSITION SW	When setting selector lever to "1" position.	ON
	When setting selector lever to other positions.	OFF

OK or NG

TROUBLE DIAGNOSIS FOR SYMPTOMS

< SERVICE INFORMATION >

OK >> GO TO 3

NG >> Check transmission range switch. Refer to [AT-175, "Component Inspection"](#) .

2.CHECK TRANSMISSION RANGE SWITCH CIRCUIT

⊗ Without CONSULT-III

1. Turn ignition switch ON. (Do not start engine.)
2. Check voltage between TCM connector terminals and ground while moving selector lever through each position. Refer to [AT-91, "Wiring Diagram - AT - TR/SW"](#) .

Selector lever position	Terminal				
	36	35	34	27	26
"P", "N"	B	0	0	0	0
"R"	0	B	0	0	0
"D"	0	0	B	0	0
"2"	0	0	0	B	0
"1"	0	0	0	0	B

B: Battery voltage

0: 0V

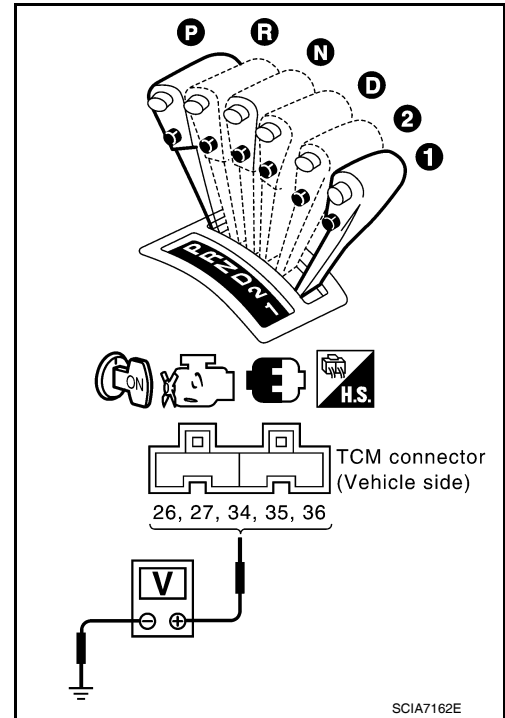

SCIA7162E

OK or NG

OK >> GO TO 3

NG >> Check transmission range switch. Refer to [AT-175, "Component Inspection"](#) .

3.CHECK A/T POSITION

Check A/T position. Refer to [AT-217, "Checking of A/T Position"](#) .

OK or NG

OK >> GO TO 4.

NG >> Adjust A/T position. Refer to [AT-217, "Adjustment of A/T Position"](#) .

4.CHECK OUTPUT SPEED SENSOR AND VEHICLE SPEED SIGNAL CIRCUIT

Check output speed sensor and vehicle speed signal circuit. Refer to [AT-100](#) and/or [AT-153](#) .

OK or NG

OK >> GO TO 5.

NG >> Repair or replace output speed sensor and/or vehicle speed signal circuits.

5.CHECK A/T FLUID CONDITION

1. Remove oil pan. Refer to [AT-237, "Component"](#) .

2. Check A/T fluid condition. Refer to [AT-51, "Inspections Before Trouble Diagnosis"](#) .

OK or NG

OK >> GO TO 7.

NG >> GO TO 6.

6.DETECT MALFUNCTIONING ITEM

1. Remove control valve assembly. Refer to [AT-222, "Control Valve Assembly and Accumulators"](#) .

2. Check the following items:

- Shift valve A
- Shift solenoid valve A

TROUBLE DIAGNOSIS FOR SYMPTOMS

< SERVICE INFORMATION >

- Overrun clutch control valve
- Overrun clutch solenoid valve
- 3. Disassemble A/T. Refer to [AT-257, "Disassembly"](#) .
- 4. Check the following items:
 - Servo piston assembly
 - Brake band

OK or NG

- OK >> GO TO 7.
- NG >> Repair or replace damaged parts.

7.CHECK SYMPTOM

Check again. Refer to [AT-62, "Cruise Test - Part 3"](#) .

OK or NG

- OK >> **INSPECTION END**
- NG >> GO TO 8.

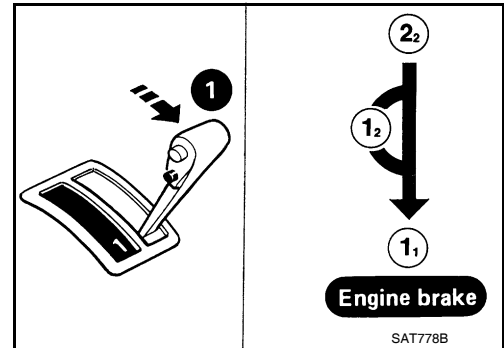

8.CHECK TCM

1. Check TCM input/output signals. Refer to [AT-75, "TCM Terminal and Reference Value"](#) .
2. If NG, recheck TCM pin terminals for damage or loose connection with harness connector.

OK or NG

- OK >> **INSPECTION END**
- NG >> Repair or replace damaged parts.

Vehicle Does Not Decelerate by Engine Brake

INFOID:000000005928265

SYMPTOM:

- Vehicle does not decelerate by engine brake when shifting from 22 (12) to 11 "Cruise Test — Part 3".
- Vehicle does not decelerate by engine brake when OD OFF (OD OFF indicator lamp is on) on "Cruise Test — Part 3".
- Vehicle does not decelerate by engine brake when shifting A/T from "D" to "2" position on "Cruise Test — Part 3".

DIAGNOSTIC PROCEDURE

1.CHECK CAN COMMUNICATION LINE

Perform self-diagnosis. Refer to [AT-77, "CONSULT-III Function \(TRANSMISSION\)"](#) or [AT-82, "Diagnosis Procedure without CONSULT-III"](#) .

Is a malfunction in CAN communication indicated in the results?

- YES >> Check CAN communication line. Refer to [AT-87](#) .
- NO >> GO TO 2.

2.CHECK OVERDRIVE CONTROL SWITCH CIRCUIT

Ⓜ With CONSULT-III

1. Turn ignition switch ON. (Do not start engine)
2. Select "TCM INPUT SIGNALS" in "DATA MONITOR" mode for "TRANSMISSION" with CONSULT-III.
3. Read out "OVERDRIVE SW".
Check the signal of the overdrive control switch is indicated properly.

TROUBLE DIAGNOSIS FOR SYMPTOMS

< SERVICE INFORMATION >

Item name	Overdrive control switch Condition	Display value
OVERDRIVE SW	Depressed	ON
	Released	OFF

⊗ Without CONSULT-III

1. Turn ignition switch ON. (Do not start engine)
2. Check voltage between A/T shift selector harness connector terminal and ground. Refer to [AT-177, "Wiring Diagram - AT - NON-DTC"](#) .

Item	Connector	Terminal	Overdrive control switch Condition	Judgement standard (Approx.)
A/T shift selector harness connector (Overdrive control switch)	M38	1 - Ground	Released	Battery voltage
			Depressed	0V

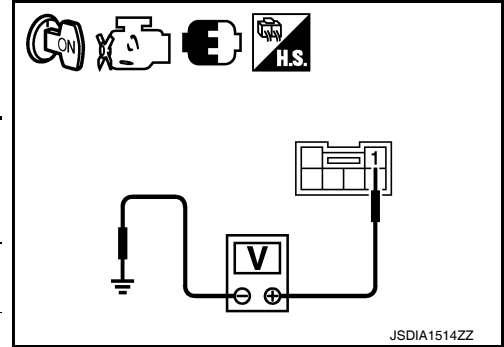

OK or NG

- OK (With CONSULT-III)>>GO TO 3.
 OK (Without CONSULT-III)>>GO TO 4.
 NG >> Check overdrive control switch. Refer to [AT-175, "Component Inspection"](#) .

3. CHECK TRANSMISSION RANGE SWITCH CIRCUIT

Ⓜ With CONSULT-III

1. Turn ignition switch ON. (Do not start engine.)
2. Select "TCM INPUT SIGNALS" in "DATA MONITOR" mode for "TRANSMISSION" with CONSULT-III.
3. Read out "P·N", "R", "D", "2" and "1" position switches moving selector lever to each position.

Monitor item	Condition	Display value
PN POSI SW	When setting selector lever to "N" or "P" position.	ON
	When setting selector lever to other positions.	OFF
R POSITION SW	When setting selector lever to "R" position.	ON
	When setting selector lever to other positions.	OFF
D POSITION SW	When setting selector lever to "D" positions.	ON
	When setting selector lever to other positions.	OFF
2 POSITION SW	When setting selector lever to "2" position.	ON
	When setting selector lever to other positions.	OFF
1 POSITION SW	When setting selector lever to "1" position.	ON
	When setting selector lever to other positions.	OFF

OK or NG

- OK >> GO TO 5
 NG >> Check transmission range switch. Refer to [AT-175, "Component Inspection"](#) .

4. CHECK TRANSMISSION RANGE SWITCH CIRCUIT

⊗ Without CONSULT-III

1. Turn ignition switch ON. (Do not start engine.)

TROUBLE DIAGNOSIS FOR SYMPTOMS

< SERVICE INFORMATION >

- Check voltage between TCM connector terminals and ground while moving selector lever through each position. Refer to [AT-91. "Wiring Diagram - AT - TR/SW"](#).

Selector lever position	Terminal				
	36	35	34	27	26
"P", "N"	B	0	0	0	0
"R"	0	B	0	0	0
"D"	0	0	B	0	0
"2"	0	0	0	B	0
"1"	0	0	0	0	B

B: Battery voltage

0: 0V

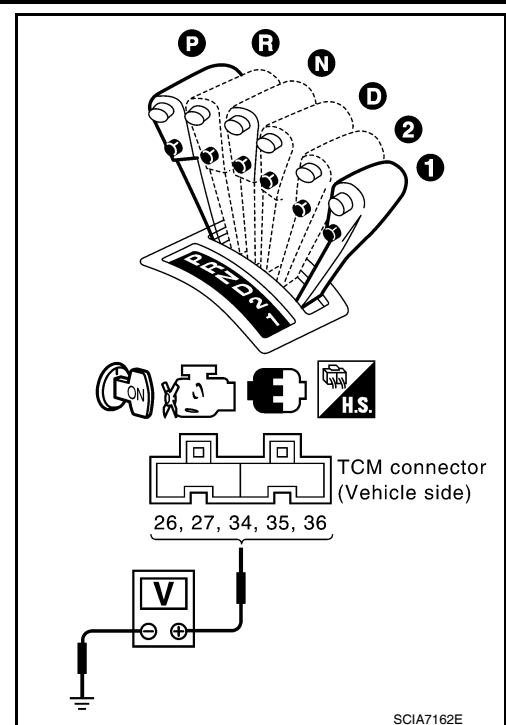

OK or NG

OK >> GO TO 5

NG >> Check transmission range switch. Refer to [AT-175. "Component Inspection"](#).

5. CHECK A/T POSITION

Check A/T position. Refer to [AT-217. "Checking of A/T Position"](#).

OK or NG

OK >> GO TO 6.

NG >> Adjust A/T position. Refer to [AT-217. "Adjustment of A/T Position"](#).

6. CHECK OUTPUT SPEED SENSOR AND VEHICLE SPEED SIGNAL CIRCUIT

Check output speed sensor and vehicle speed signal circuit. Refer to [AT-100](#) and/or [AT-153](#).

OK or NG

OK >> GO TO 7.

NG >> Repair or replace output speed sensor and/or vehicle speed signal circuits.

7. CHECK ACCELERATOR PEDAL POSITION SENSOR

Check accelerator pedal position sensor. Refer to [EC-415. "Description"](#) (HR16DE), [EC-982. "Component Description"](#) (MR18DE).

OK or NG

OK >> GO TO 8.

NG >> Repair or replace accelerator pedal position sensor.

8. CHECK A/T FLUID CONDITION

1. Remove oil pan. Refer to [AT-237. "Component"](#).

2. Check A/T fluid condition. Refer to [AT-51. "Inspections Before Trouble Diagnosis"](#).

OK or NG

OK >> GO TO 10.

NG >> GO TO 9.

9. DETECT MALFUNCTIONING ITEM

1. Remove control valve assembly. Refer to [AT-222. "Control Valve Assembly and Accumulators"](#).

2. Check the following.

- Shift valve A

TROUBLE DIAGNOSIS FOR SYMPTOMS

< SERVICE INFORMATION >

- Overrun clutch solenoid valve
- 3. Disassemble A/T. Refer to [AT-257, "Disassembly"](#) .
- 4. Check the following.
 - Overrun clutch assembly. Refer to [AT-307, "Forward and Overrun Clutches"](#) .
 - Low & reverse brake assembly. Refer to [AT-314, "Low & Reverse Brake"](#) .

OK or NG

- OK >> GO TO 10.
- NG >> Repair or replace damaged parts.

10. CHECK SYMPTOM

Check again. Refer to [AT-62, "Cruise Test - Part 3"](#) .

OK or NG

- OK >> **INSPECTION END**
- NG >> GO TO 11.

11. CHECK TCM

1. Check TCM input/output signals. Refer to [AT-75, "TCM Terminal and Reference Value"](#) .
2. If NG, recheck TCM pin terminals for damage or loose connection with harness connector.

OK or NG

- OK >> **INSPECTION END**
- NG >> Repair or replace damaged parts.

TCM Self-Diagnosis Does Not Activate

INFOID:000000005928266

SYMPTOM:

OD OFF indicator lamp does not come on in TCM self-diagnostic procedure even if the lamp circuit is good.

DESCRIPTION

- Transmission range switch (1)
Transmission range switch assembly includes a transaxle position switch. The transaxle position switch detects the selector lever position and sends a signal to the TCM.
- Overdrive control switch
Overdrive control switch detects the switch position (ON or OFF) and sends the signal via CAN communication to the TCM.

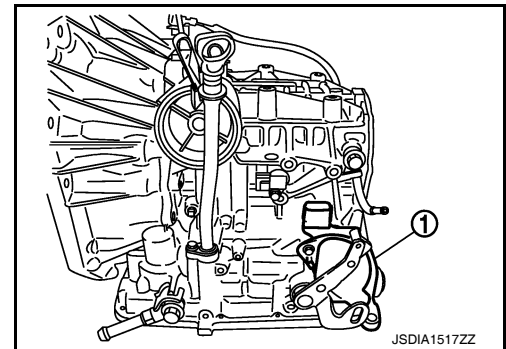

JSDIA1517ZZ

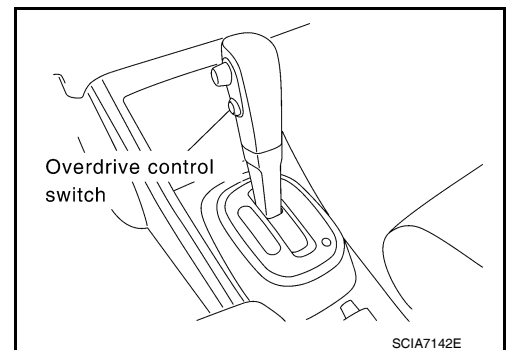

SCIA7142E

TROUBLE DIAGNOSIS FOR SYMPTOMS

< SERVICE INFORMATION >

- Closed throttle position signal and wide open throttle position signal
ECM judges throttle opening based on a signal from accelerator pedal position sensor, and sends the signal via CAN communication to the TCM.

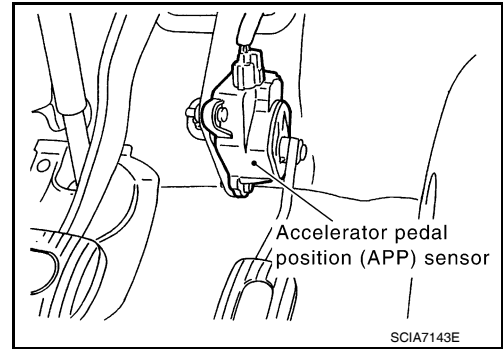

DIAGNOSTIC PROCEDURE

NOTE:

The diagnostic procedure includes inspection for the transmission range switch, overdrive control switch, closed throttle position signal and wide open throttle position signal circuit. Refer to [AT-171](#).

A
B
AT
D
E
F
G
H
I
J
K
L
M
N
O
P

A/T SHIFT LOCK SYSTEM

< SERVICE INFORMATION >

A/T SHIFT LOCK SYSTEM

Description

INFOID:000000005928267

WITH INTELLIGENT KEY

- The mechanical key interlock mechanism also operates as a shift lock:
 - With the ignition knob switch turned to ON, selector lever cannot be shifted from “P” position to any other position unless brake pedal is depressed.
 - With the ignition knob switch turned to OFF, selector lever cannot be shifted from “P” position to any other position.
- The shift lock and key interlock mechanisms are controlled by the ON-OFF operation of the shift lock solenoid and by the operation of the ignition knob switch, respectively.

WITHOUT INTELLIGENT KEY

- The mechanical key interlock mechanism also operates as a shift lock:
 - With the ignition switch turned to ON, selector lever cannot be shifted from “P” position to any other position unless brake pedal is depressed.
 - With the key removed, selector lever cannot be shifted from “P” position to any other position.
 - The key cannot be removed unless selector lever is placed in “P” position.
- The shift lock and key interlock mechanisms are controlled by the ON-OFF operation of the shift lock solenoid and by the operation of the rotator and slider located inside key cylinder, respectively.

A/T SHIFT LOCK SYSTEM

< SERVICE INFORMATION >

Shift Lock System Parts Location

INFOID:000000005928268

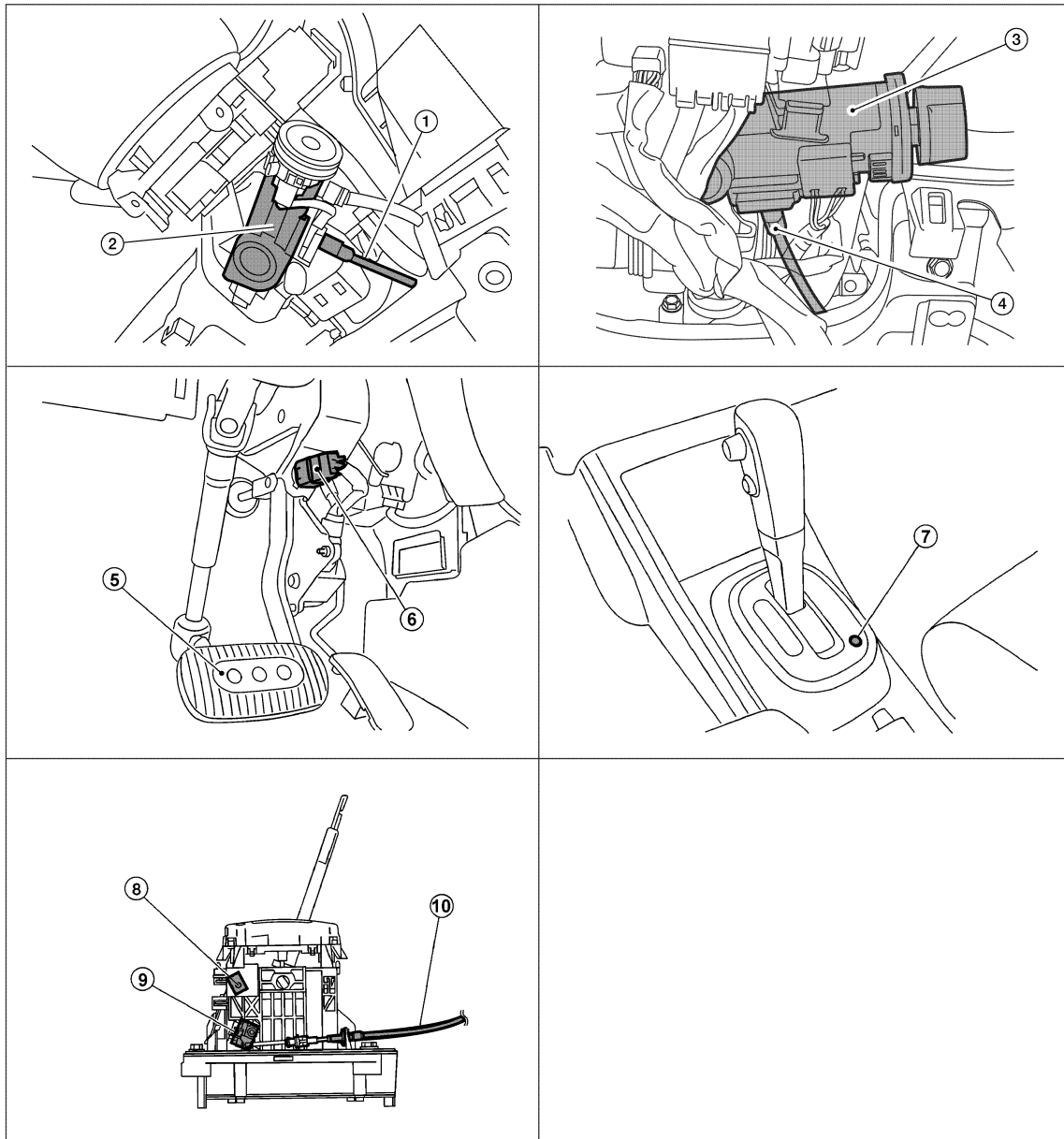

AWDIA0772ZZ

- | | | |
|--|---|--|
| 1. Key interlock cable (Without Intelligent Key) | 2. Key cylinder (Without Intelligent Key) | 3. Ignition knob switch (With Intelligent Key) |
| 4. Key interlock cable (With Intelligent Key) | 5. Brake pedal | 6. Stop lamp switch |
| 7. Shift lock release button | 8. Park position switch | 9. Shift lock solenoid |
| 10. Key interlock cable | | |

A
B
AT
D
E
F
G
H
I
J
K
L
M
N
O
P

A/T SHIFT LOCK SYSTEM

< SERVICE INFORMATION >

Wiring Diagram - AT - SHIFT

INFOID:000000005928269

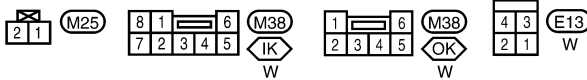
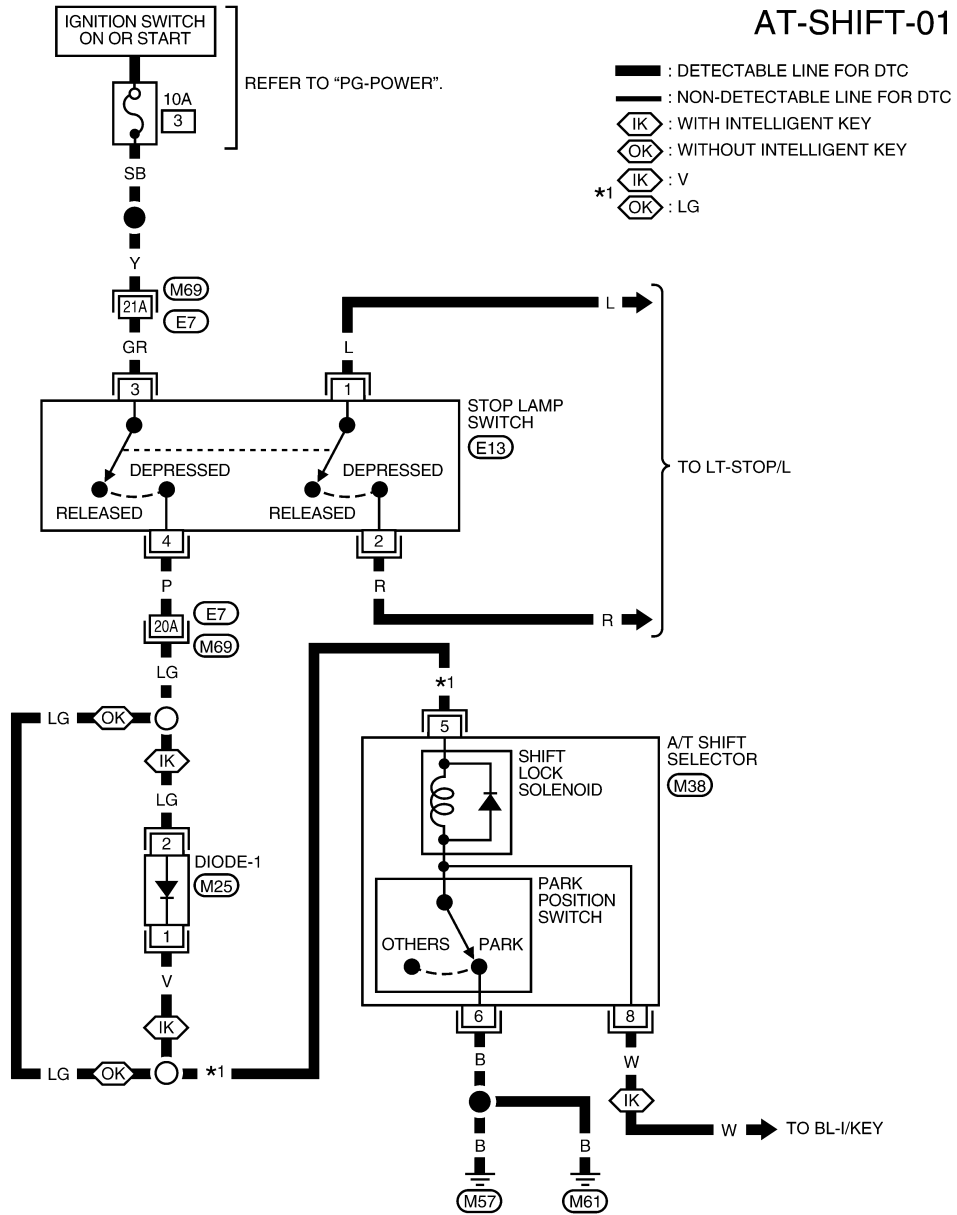

REFER TO THE FOLLOWING.

M69 - SUPER MULTIPLE JUNCTION (SMJ)

ABDWA0418GB

Diagnosis Procedure

INFOID:000000005928270

SYMPTOM 1:

- Selector lever cannot be moved from "P" position with ignition switch in ON position and brake pedal depressed.

A/T SHIFT LOCK SYSTEM

< SERVICE INFORMATION >

- Selector lever can be moved from “P” position with ignition key in ON position and brake pedal released.
- Selector lever can be moved from “P” position when ignition switch is removed from key cylinder.

SYMPTOM 2:

- Ignition key cannot be removed when selector lever is set to “P” position.
- Ignition key can be removed when selector lever is set to any position except “P” position.

1. CHECK KEY INTERLOCK CABLE

Check key interlock cable for damage.

OK or NG

OK >> GO TO 2.

NG >> Repair key interlock cable. Refer to [AT-219, "Removal and Installation"](#).

2. CHECK A/T POSITION

Check A/T position. Refer to [AT-217, "Checking of A/T Position"](#).

OK or NG

OK >> GO TO 3.

NG >> Adjust control cable. Refer to [AT-217, "Adjustment of A/T Position"](#).

3. CHECK SHIFT LOCK SOLENOID AND PARK POSITION SWITCH

1. Turn ignition switch ON. (Do not start engine.)
2. Selector lever is set in “P” position.
3. Check operation sound.

Condition	Brake pedal	Operation sound
When ignition switch is turned to ON position and selector lever is set in “P” position.	Depressed	Yes
	Released	

OK or NG

OK >> **INSPECTION END**

NG - 1 >> With intelligent key: GO TO 4.

NG - 2 >> Without intelligent key: GO TO 5.

4. CHECK POWER SOURCE

1. Turn ignition switch ON. (Do not start engine.)
2. Check voltage between A/T shift selector harness connector terminal 5 and ground.

Voltage:

Brake pedal depressed: Battery voltage

Brake pedal released: 0V

OK or NG

OK >> GO TO 8.

NG >> GO TO 6.

5. CHECK POWER SOURCE

1. Turn ignition switch ON. (Do not start engine.)

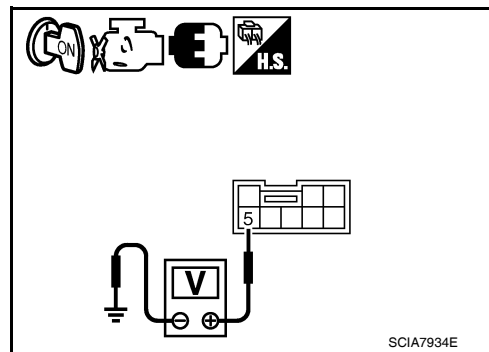

A/T SHIFT LOCK SYSTEM

< SERVICE INFORMATION >

- Check voltage between A/T shift selector harness connector terminal 5 and ground.

Voltage:

Brake pedal depressed: Battery voltage

Brake pedal released: 0V

OK or NG

- OK >> GO TO 9.
NG >> GO TO 6.

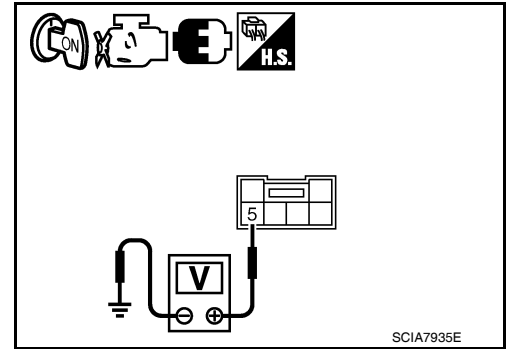

6. CHECK STOP LAMP SWITCH

- Turn ignition switch OFF.
- Disconnect stop lamp switch harness connector.
- Check continuity between stop lamp switch terminals 3 and 4.

Condition	Continuity
When brake pedal is depressed	Yes
When brake pedal is released	No

Check stop lamp switch after adjusting brake pedal. Refer to [BR-6](#).

OK or NG

- OK >> GO TO 7.
NG >> Repair or replace damaged parts.

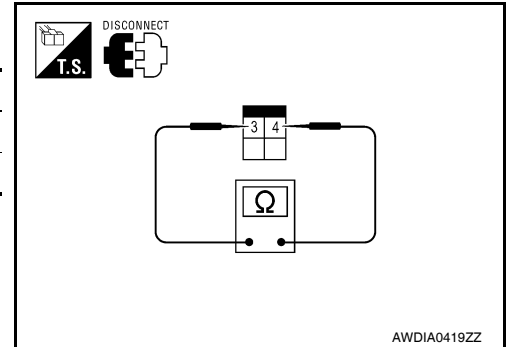

7. DETECT MALFUNCTIONING ITEM

Check the following. If any items are damaged, repair or replace damaged parts.

- Harness for short or open between ignition switch and stop lamp switch harness connector
- Harness for short or open between stop lamp switch harness connector and A/T shift selector harness connector
- 10A fuse [No.3, located in the fuse block (J/B)]
- Ignition switch, Refer to [PG-4](#).

OK or NG

- OK >> **INSPECTION END**
NG >> Repair or replace damaged parts.

8. CHECK GROUND CIRCUIT

- Turn ignition switch OFF.
- Disconnect A/T shift selector harness connector.
- Check continuity between A/T shift selector harness connector terminal 6 and ground.

Continuity should exist.

- Connect A/T shift selector harness connector.

OK or NG

- OK >> Replace shift lock solenoid and park position switch assembly. Refer to [AT-216, "A/T Shift Selector Disassembly and Assembly"](#).
NG >> Repair open circuit or short to ground or short to power in harness or connectors.

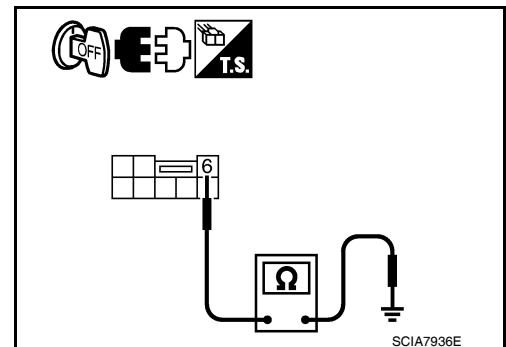

9. CHECK GROUND CIRCUIT

- Turn ignition switch OFF.
- Disconnect A/T shift selector harness connector.

A/T SHIFT LOCK SYSTEM

< SERVICE INFORMATION >

3. Check continuity between A/T shift selector harness connector terminal 6 and ground.

Continuity should exist.

4. Connect A/T shift selector harness connector.

OK or NG

- OK >> Replace shift lock solenoid and park position switch assembly. Refer to [AT-216, "A/T Shift Selector Disassembly and Assembly"](#).
- NG >> Repair open circuit or short to ground or short to power in harness or connectors.

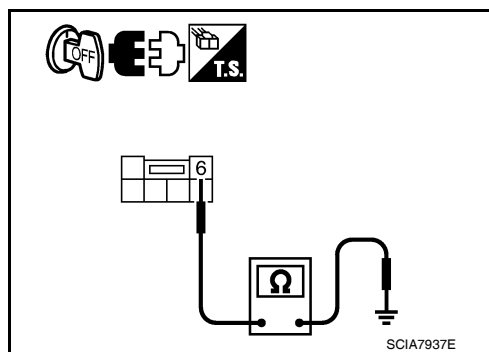

A
B
AT
D
E
F
G
H
I
J
K
L
M
N
O
P

TRANSMISSION CONTROL MODULE

< SERVICE INFORMATION >

TRANSMISSION CONTROL MODULE

Removal and Installation

INFOID:000000005928271

COMPONENTS

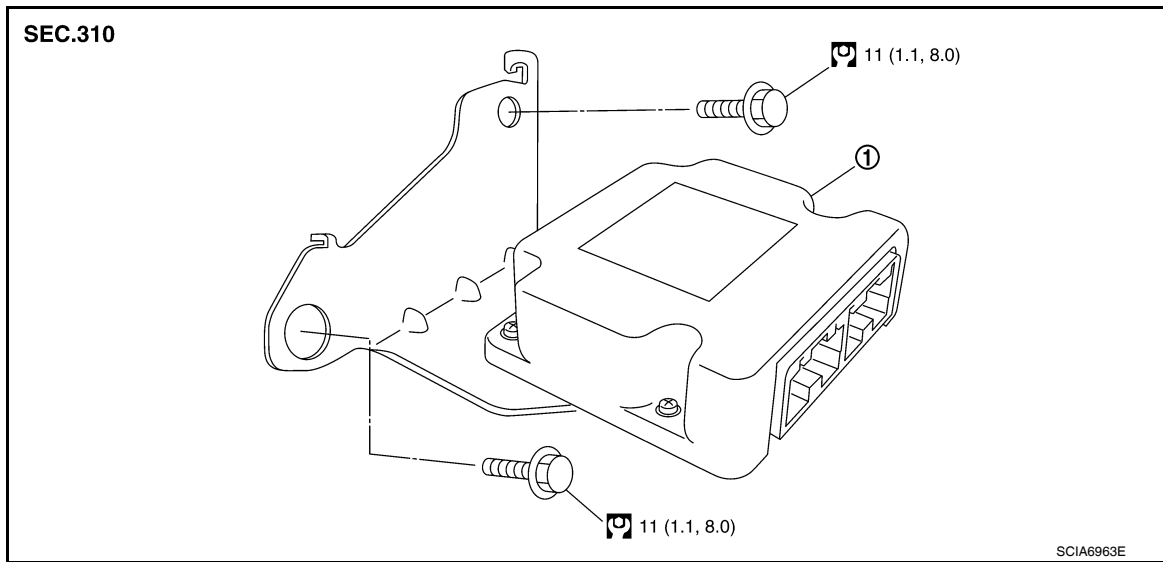

1. TCM

REMOVAL

1. Disconnect the battery negative terminal.
2. Disconnect TCM harness connectors (1) from TCM (2).
 - Instrument lower finisher (3)
3. Remove TCM (2).

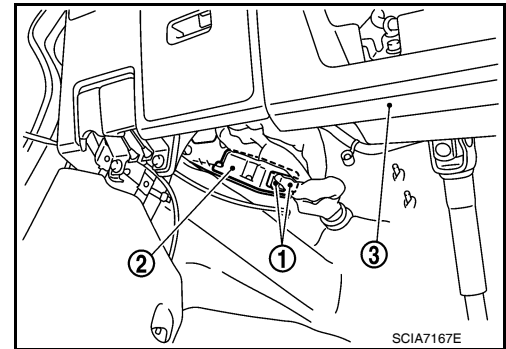

INSTALLATION

Installation is in the reverse order of removal.

SHIFT CONTROL SYSTEM

< SERVICE INFORMATION >

SHIFT CONTROL SYSTEM

A/T Shift Selector Removal and Installation

INFOID:000000005928272

A/T SHIFT SELECTOR COMPONENTS

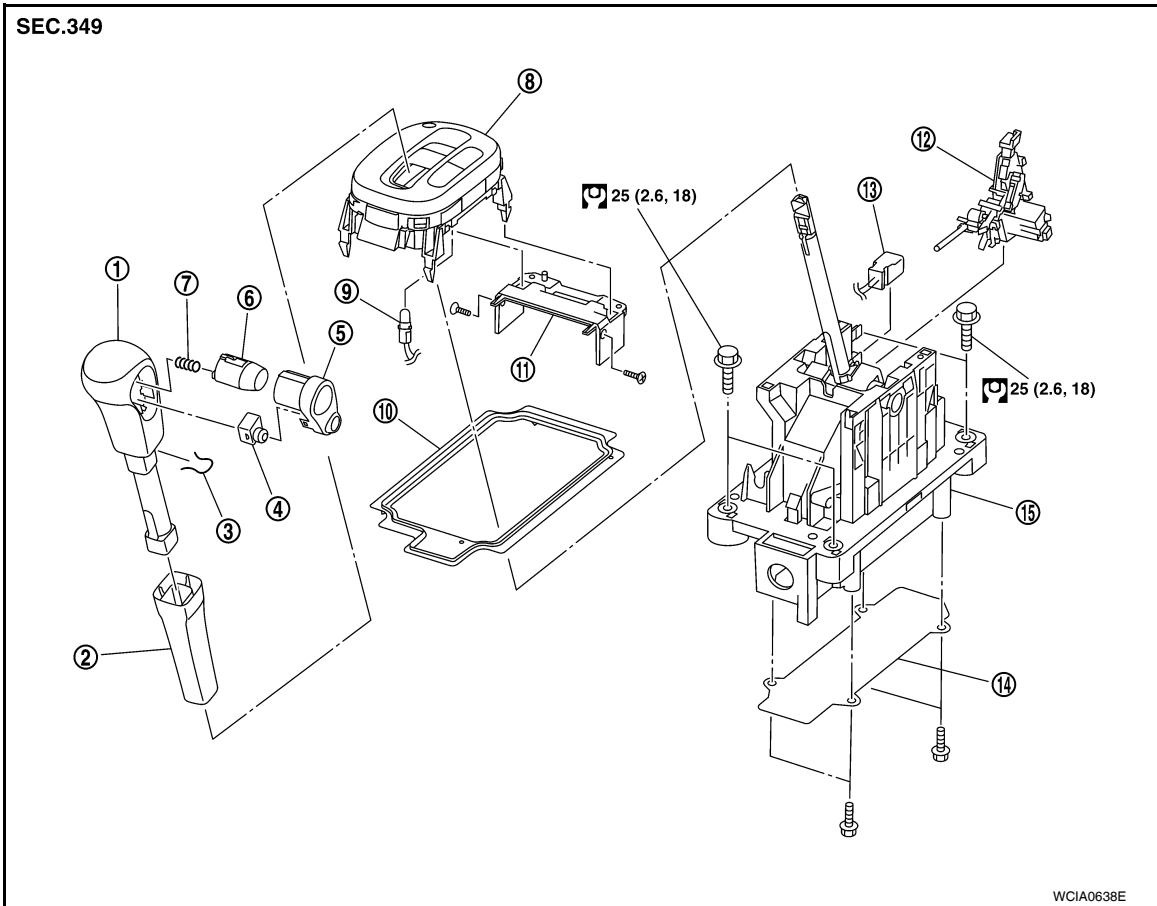

- | | | |
|--|-----------------------------------|---|
| 1. Shift selector handle | 2. Shift selector handle cover | 3. Shift selector handle clip |
| 4. Overdrive control switch | 5. Shift selector handle finisher | 6. Shift selector handle button |
| 7. Shift selector handle spring | 8. Position indicator plate | 9. Position lamp |
| 10. Dust cover | 11. Bracket | 12. Shift lock solenoid and park position switch assembly |
| 13. A/T shift selector harness connector | 14. Plate | 15. A/T shift selector assembly |

CONTROL CABLE COMPONENTS

A
B
AT
D
E
F
G
H
I
J
K
L
M
N
O
P

SHIFT CONTROL SYSTEM

< SERVICE INFORMATION >

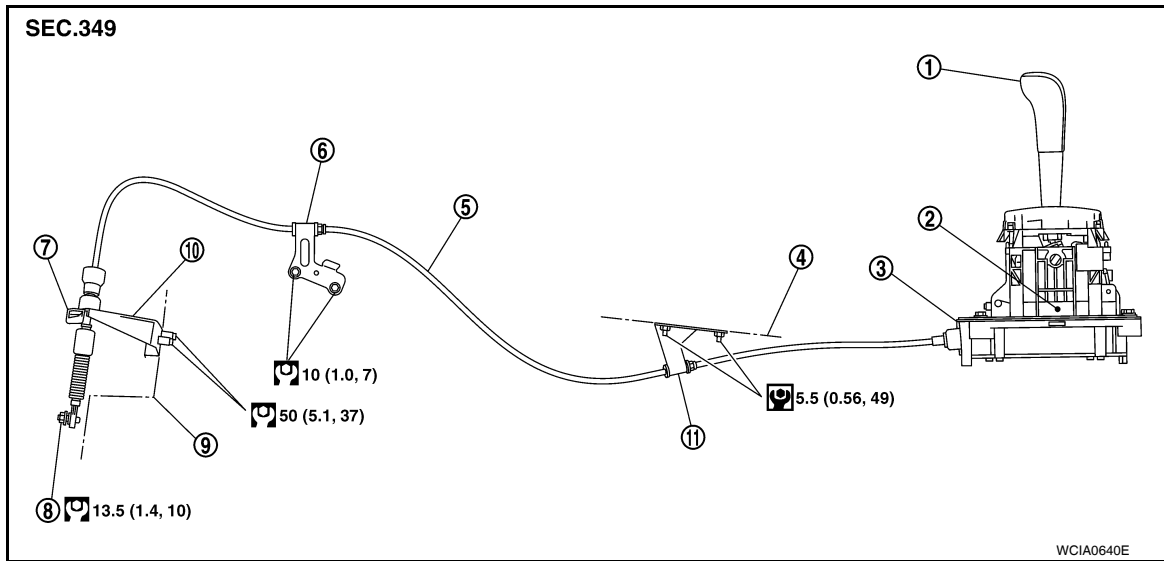

- | | | |
|--------------------------|---------------------------------|-----------------|
| 1. Shift selector handle | 2. A/T shift selector assembly | 3. Lock plate |
| 4. Floor panel | 5. Shift selector control cable | 6. Bracket |
| 7. Lock plate | 8. Lock nut | 9. A/T assembly |
| 10. Bracket | 11. Bracket | |

REMOVAL

CAUTION:

Make sure that parking brake is applied before removal/installation.

1. Place the shift selector in the "N" position.
2. Remove the center console assembly. Refer to [IP-11](#).
3. Disconnect the A/T shift selector harness connector (1).
4. Remove the key interlock cable from the A/T shift selector assembly. Refer to [AT-219, "Removal and Installation"](#).

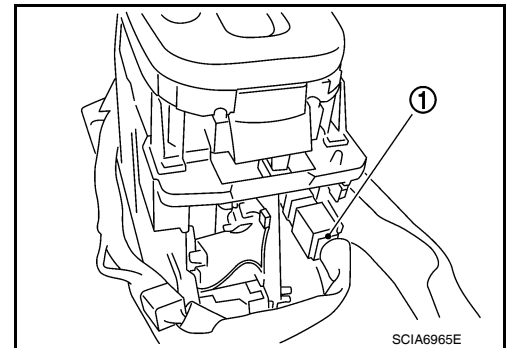

5. Remove the bolts (A) from the A/T shift selector assembly (1).
6. Remove exhaust front tube, center muffler and heat plates. Refer to [EM-141](#).

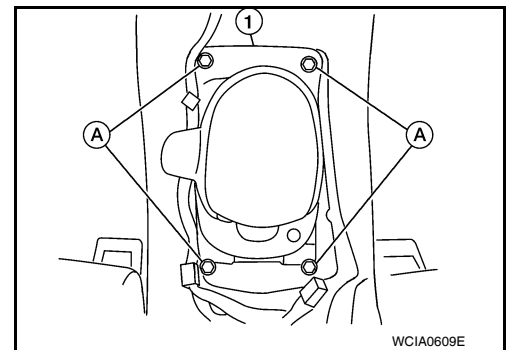

SHIFT CONTROL SYSTEM

< SERVICE INFORMATION >

7. Remove the plate (1) from the A/T shift selector assembly.

⇐: Vehicle front

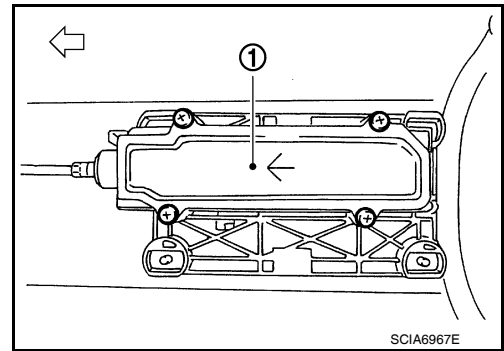

8. Remove the lock plate (1) from the shift selector control cable (2).

⇐: Vehicle front

9. Remove the shift selector control cable (2) from the A/T shift selector assembly.

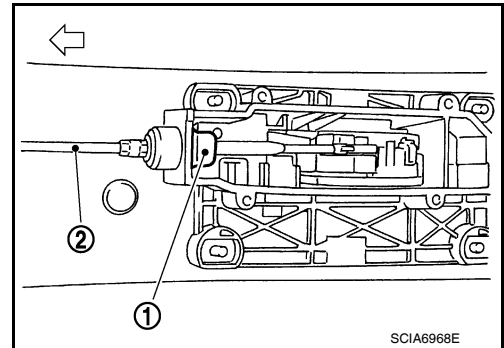

10. Insert suitable tool at points (A) and (B) as shown, and press both tabs (E) and (F) at the front (C) and rear (D) slightly toward the center of the A/T shift selector assembly to remove the A/T shift selector assembly from the underside of the vehicle.

⇐: Vehicle front

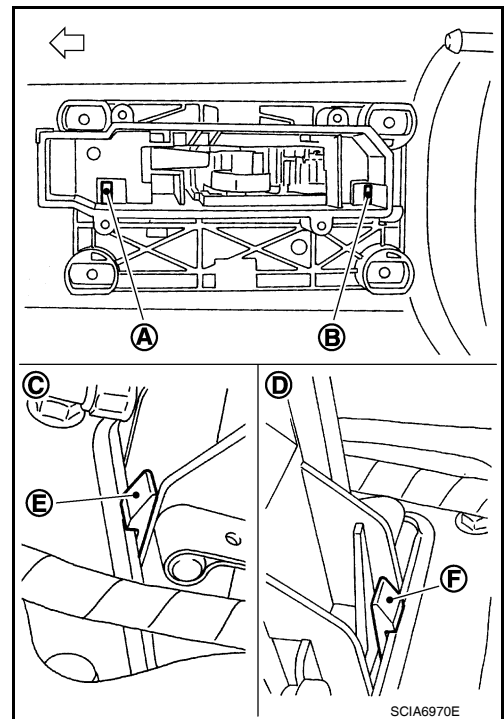

INSTALLATION

Installation is in the reverse order of removal.

A
B
AT
D
E
F
G
H
I
J
K
L
M
N
O
P

SHIFT CONTROL SYSTEM

< SERVICE INFORMATION >

- When installing the shift selector control cable (1) to the A/T shift selector assembly (2), make sure that the shift selector control cable (1) is fully pressed in with the ribbed surface (A) facing downward from the vehicle.

⇐: Vehicle front

- After installation is completed, adjust and check the A/T position. Refer to [AT-217, "Adjustment of A/T Position"](#) and [AT-217, "Checking of A/T Position"](#).

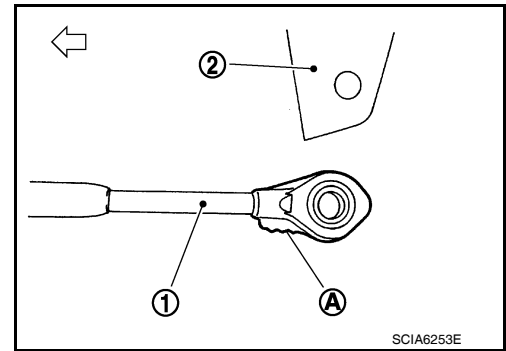

INFOID:000000005928273

A/T Shift Selector Disassembly and Assembly

DISASSEMBLY

NOTE:

Refer to [AT-213, "A/T Shift Selector Removal and Installation"](#) to disassemble.

- Remove shift selector handle from A/T shift selector assembly. Refer to [AT-216, "Shift Selector Handle Removal and Installation"](#).
- Remove position lamp from position indicator plate (1).
- Insert a suitable tool to (A) (at 4 locations) as shown, and bend each hook slightly to raise position indicator plate (1) and remove from A/T shift selector assembly (2).
- Remove bracket from A/T shift selector assembly (2).
- Remove A/T shift selector harness connector from A/T shift selector assembly (2).
- Release tabs (A) on shift lock solenoid and park position switch assembly from hooks (B) on A/T shift selector assembly to shift lock solenoid and park position switch assembly.

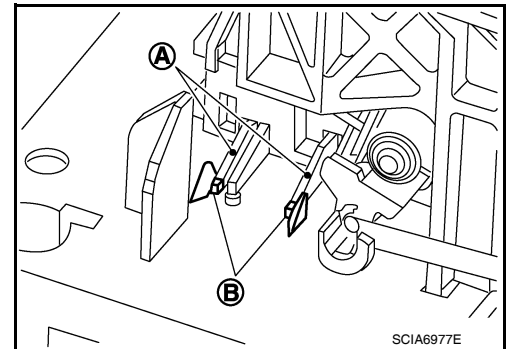
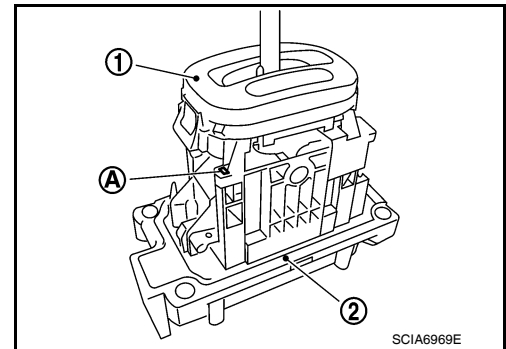

ASSEMBLY

Assemble in the reverse order of disassembly.

Shift Selector Handle Removal and Installation

INFOID:000000005928274

REMOVAL

CAUTION:

Make sure that parking brake is applied before removal/installation.

SHIFT CONTROL SYSTEM

< SERVICE INFORMATION >

1. Place the shift selector handle (1) in "N" position.
2. Slide shift selector handle cover (2) downward.
3. Pull out shift selector handle clip (3) from shift selector handle (1).
4. Remove shift selector handle (1) and shift selector handle cover (2) as a set from shift selector.

CAUTION:

Do not push shift selector handle button.

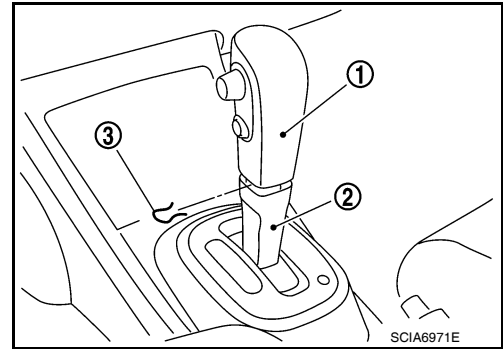

INSTALLATION

1. Insert shift selector handle clip (1) to shift selector handle (2).
2. Install shift selector handle cover (3) to shift selector handle (2).
3. Place the shift selector in "N" position.
4. Install shift selector handle over shift selector until a click is felt.

CAUTION:

- Do not tilt shift selector handle when installing. Install it straight, and do not tap or apply any shock to install it.
- Do not push shift selector handle button.

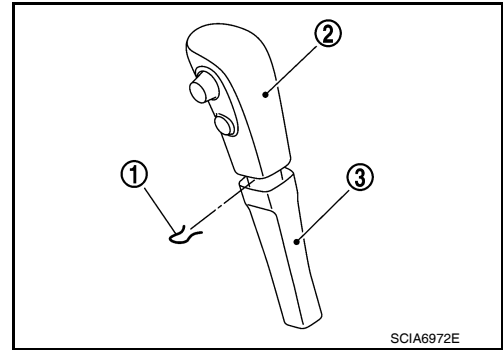

Adjustment of A/T Position

INFOID:000000005928275

Move shift selector from "P" position to "1" position. You should be able to feel the detents in each position. If the detents cannot be felt or if the position indicator is improperly aligned, the control cable needs adjustment.

CAUTION:

Make sure that parking brake is applied before adjustment.

1. Remove the air duct assembly. Refer to [EM-135](#).
2. Remove the control cable nut (A) and control cable (1) and place the manual lever (2) in the "P" position.
3. Place shift selector in "P" position.
4. Hold control cable (1) at the end and pull it with a force of 9.8 N (approximately 1 kg, 2.2 lb). Release the control cable and temporarily tighten control cable nut (A).
5. Tighten control cable nut (A) to the specified torque.

Control cable nut : Refer to [AT-213, "A/T Shift Selector Removal and Installation"](#).

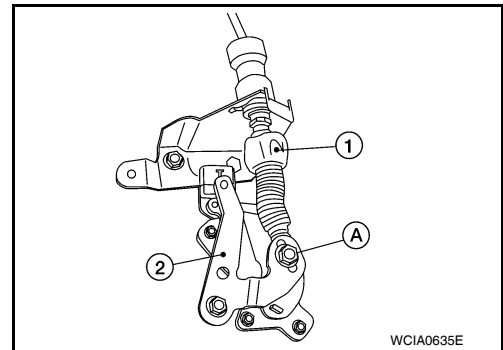

CAUTION:

Secure manual selector when tightening nut.

6. Move shift selector from "P" to "1" position again. Make sure that shift selector moves smoothly.
7. Check A/T position. Refer to [AT-217, "Checking of A/T Position"](#).
8. Install air duct assembly. Refer to [EM-135](#).

Checking of A/T Position

INFOID:000000005928276

1. Place shift selector in "P" position, and turn ignition switch ON (Do not start engine).
2. Make sure shift selector can be shifted to other than "P" position when brake pedal is depressed. Also make sure shift selector can be shifted from "P" position only when brake pedal is depressed.
3. Move shift selector and check for excessive effort, sticking, noise or rattle.
4. Confirm shift selector stops at each position with the feel of engagement when it is moved through all the positions. Check whether or not the actual position shift selector is in matches the position shown by the position indicator and the transaxle.

SHIFT CONTROL SYSTEM

< SERVICE INFORMATION >

5. The method of operating shift selector to individual positions correctly should be as shown.
 - (A): Press shift selector handle button to operate shift selector, while depressing the brake pedal.
 - (B): Press shift selector handle button to operate shift selector.
 - (C): Shift selector can be operated without pressing shift selector handle button.
6. Confirm back-up lamps illuminate only when shift selector is placed in "R" position. Confirm back-up lamps do not illuminate when shift selector is in "P" or "N" position even if it is pushed toward "R" position without pressing shift selector handle button.
7. Confirm engine can only be started with shift selector in "P" and "N" positions.
8. Make sure A/T is locked completely in "P" position.

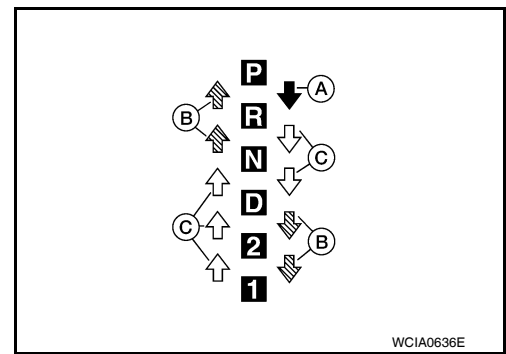

KEY INTERLOCK CABLE

< SERVICE INFORMATION >

KEY INTERLOCK CABLE

Removal and Installation

INFOID:000000005928277

COMPONENTS

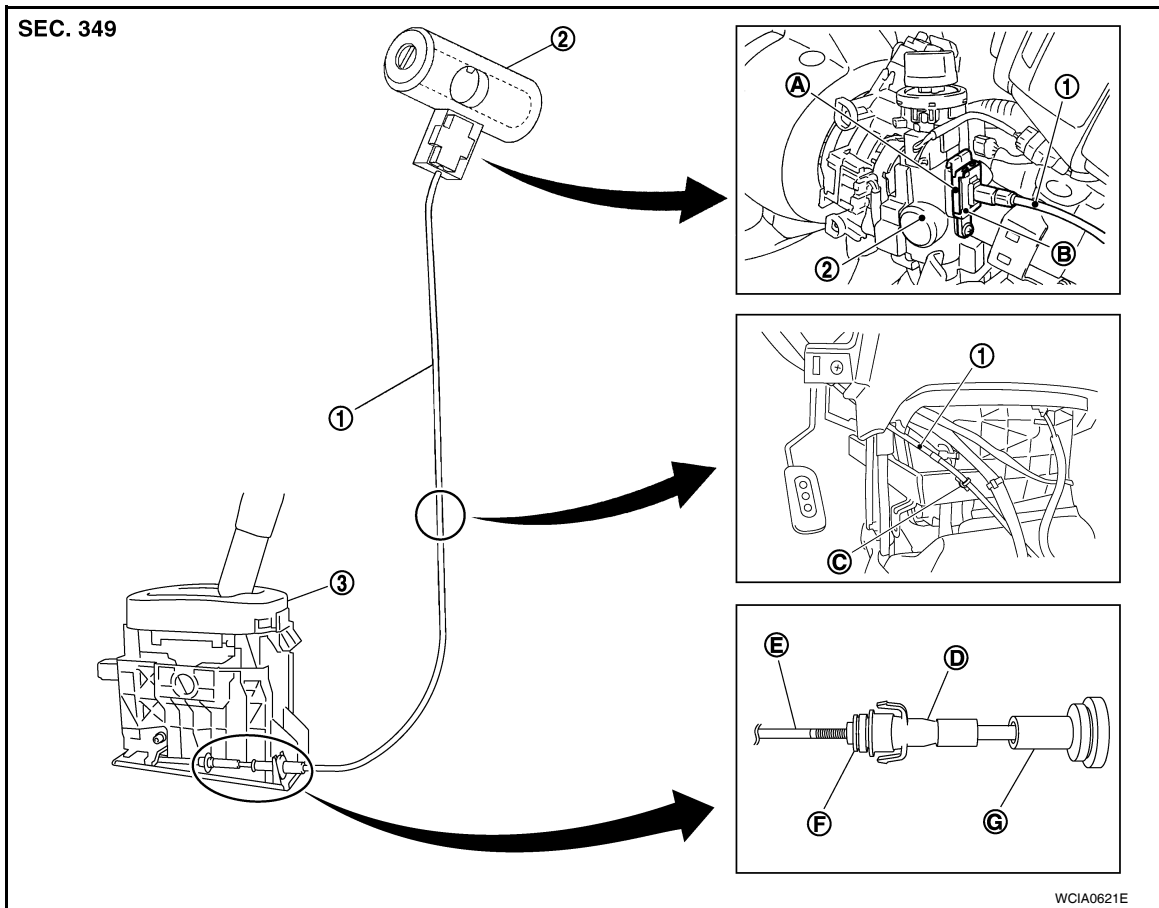

- | | | |
|------------------------|----------------------|--------------------------------|
| 1. Key interlock cable | 2. Key cylinder | 3. A/T shift selector assembly |
| A. Lock plate | B. Holder | C. Clip |
| D. Slider | E. Key interlock rod | F. Adjust holder |
| G. Casing cap | | |

REMOVAL

CAUTION:

Make sure that parking brake is applied before removal and installation.

1. Place the shift selector in the "N" position.
2. Remove the shift selector handle. Refer to [AT-216. "Shift Selector Handle Removal and Installation"](#).
3. Remove the center console assembly. Refer to [IP-11](#).
4. Slide the slider (A) toward the casing cap (B) while pressing tabs (C) on the slider to separate the slider (A) from the adjust holder (D).
5. Remove the casing cap (B) from the cable bracket on the A/T shift selector assembly.
6. Remove the key interlock cable from the key interlock rod (E).

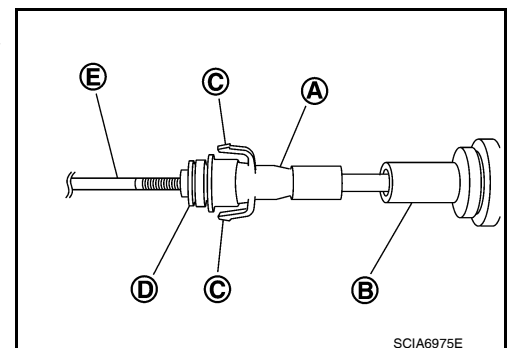

KEY INTERLOCK CABLE

< SERVICE INFORMATION >

7. Remove steering column cover (upper and lower) and instrument lower finisher. Refer to [IP-11](#).
8. Pull out the lock plate (A) from the holder (B).
9. Remove the key interlock cable (1) from the key cylinder (2).

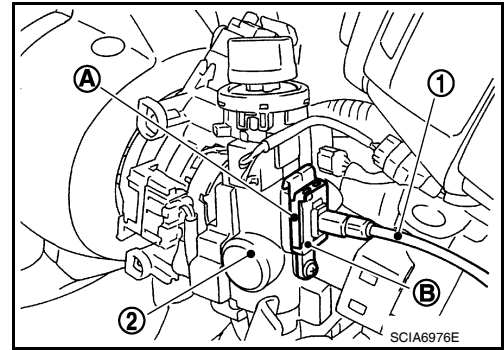

10. Remove the clip (A), and then remove the key interlock cable (1).

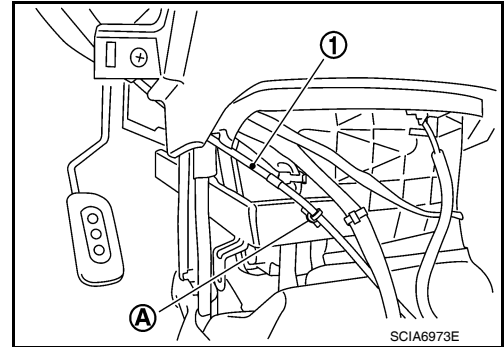

INSTALLATION

CAUTION:

- Install key interlock cable in such a way that it will not be damaged by sharp bends, twists or interference with adjacent parts.
- After installing key interlock cable to A/T shift selector assembly, make sure that casing cap and bracket are firmly secured in their positions.

1. Place the shift selector in the “P” position.
2. Turn ignition switch to “ACC” or “ON” position.
3. Set the key interlock cable (1) to the key cylinder (2).
4. Install the lock plate (A) to the holder (B).
5. Turn ignition switch to “LOCK” position.

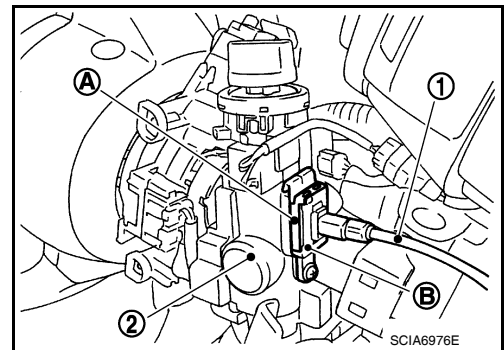

6. Temporarily install the adjust holder (A) to the key interlock rod (B).
7. Install the casing cap (C) to the cable bracket (D) on the A/T shift selector assembly.

CAUTION:

- Do not bend or twist key interlock cable excessively when installing.
- After installing key interlock cable to cable bracket (D) on A/T shift selector assembly, make sure casing cap (C) is firmly secured in cable bracket (D) on A/T shift selector assembly.
- If casing cap (C) is loose [less than 39.2 N (4.0 kg, 8.8 lb) removing force], replace key interlock cable.

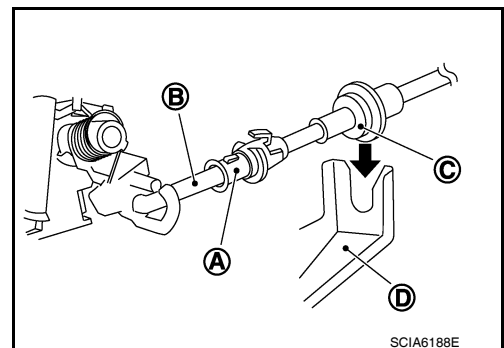

KEY INTERLOCK CABLE

< SERVICE INFORMATION >

8. Slide the slider (A) toward the key interlock rod (D) while pressing the pull lock (B) down to securely connect the adjust holder (C) with the key interlock rod (D).

CAUTION:

- Do not press tabs when holding slider (A).
- Do not apply any side to side force to key interlock rod (D) when sliding slider (A).

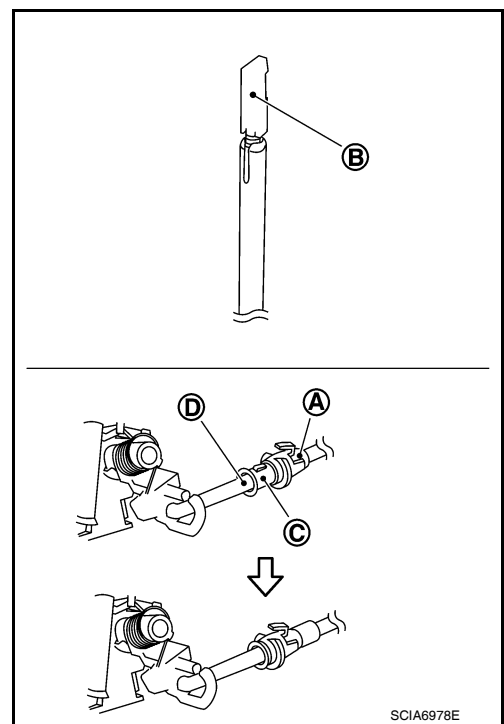

9. Secure the key interlock cable (1) with the clip (A).
10. Install steering column cover (upper and lower) and instrument lower finisher. Refer to [IP-11](#).
11. Install the center console assembly. Refer to [IP-11](#).
12. Install the shift selector handle. Refer to [AT-216](#). "[Shift Selector Handle Removal and Installation](#)".
13. Check shift lock system. Refer to [AT-206](#). "[Description](#)".

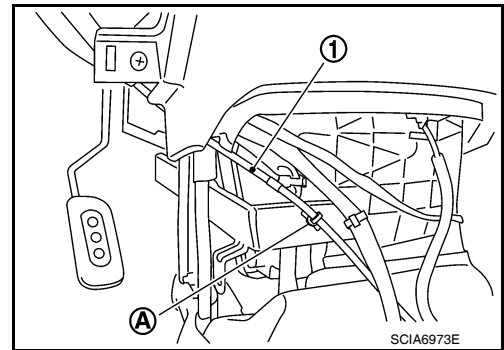

ON-VEHICLE SERVICE

< SERVICE INFORMATION >

ON-VEHICLE SERVICE

Control Valve Assembly and Accumulators

INFOID:000000005928278

COMPONENTS

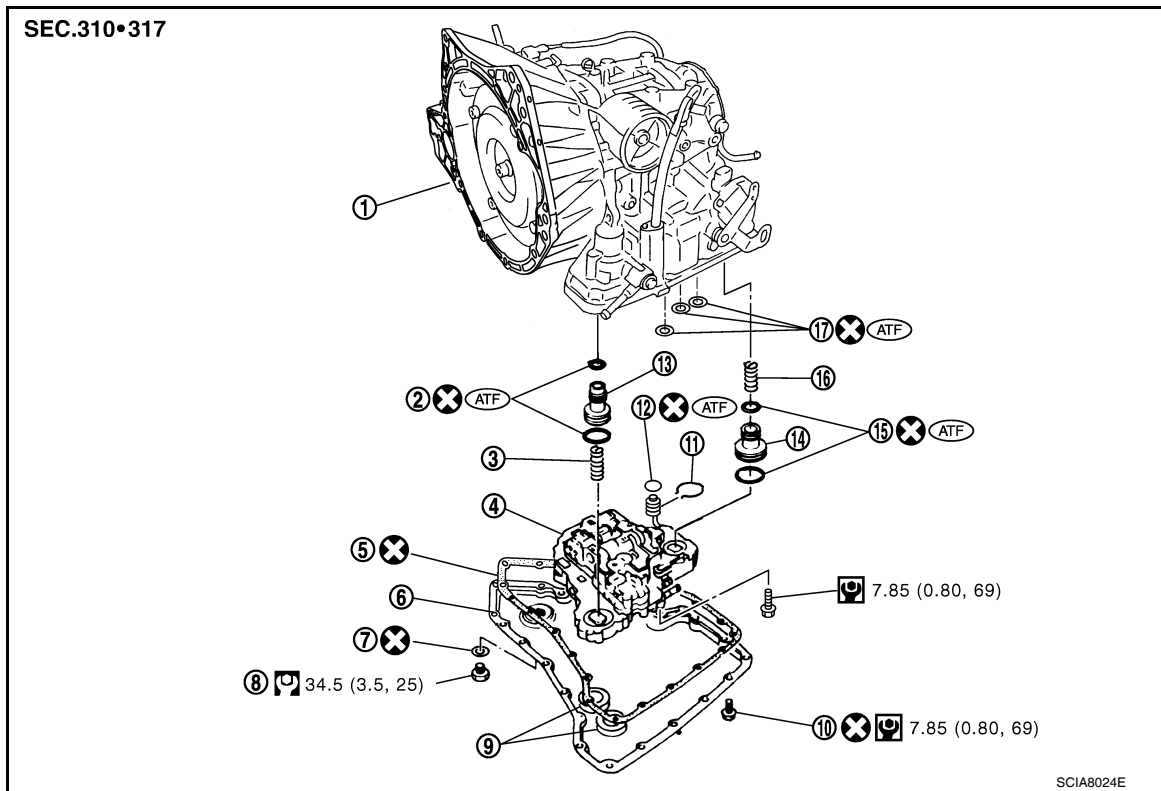

- | | | |
|--------------------------------------|----------------------------|------------------|
| 1. A/T | 2. O-ring | 3. Return spring |
| 4. Control valve assembly | 5. Oil pan gasket | 6. Oil pan |
| 7. Drain plug gasket | 8. Drain plug | 9. Magnet |
| 10. Oil pan bolt | 11. Snap ring | 12. O-ring |
| 13. Servo release accumulator piston | 14. N-D accumulator piston | 15. O-ring |
| 16. Return spring | 17. Lip seal | |

REMOVAL AND INSTALLATION

Removal

1. Disconnect the battery negative terminal.
2. Remove engine under cover and fender protector (LH). Refer to [EI-26. "Removal and Installation"](#).
3. Drain the A/T fluid. Refer to [AT-17](#).
4. Remove oil pan and oil pan gasket.
5. Check for foreign materials in oil pan to help determine cause of malfunction. If the ATF is very dark, smell burned or contains foreign particles, friction material (clutches, band) may need replacement. A tacky film that will not wipe clean indicates varnish build up. Varnish can cause valves, servo, and clutches to stick and can inhibit pump pressure.
 - If ATF contains frictional material (clutch, bands, etc.), replace radiator and flush cooler line using cleaning solvent and compressed air after repair of A/T. Refer to [CO-40](#).
6. Remove magnets from oil pan.

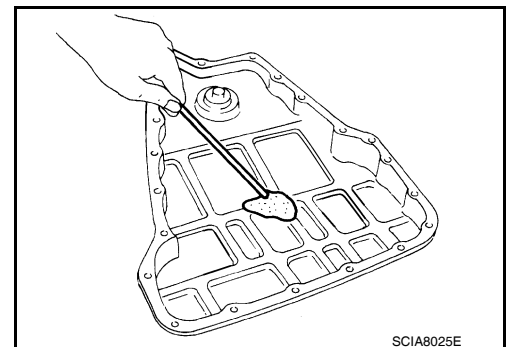

ON-VEHICLE SERVICE

< SERVICE INFORMATION >

7. Disconnect terminal cord assembly harness connector.
8. Remove snap ring from terminal body.
9. Remove terminal cord assembly by pushing terminal body into transaxle case.

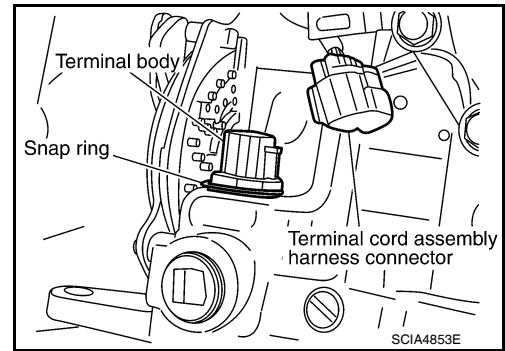

10. Remove control valve assembly bolts (A), (B) and (C).

Bolt length, number and location:

Bolt symbol	A	B	C
Bolt length "ℓ" mm (in)	40.0 mm (1.575 in)	33.0 mm (1.299 in)	43.5 mm (1.713 in)
			
Number of bolts	5	6	2

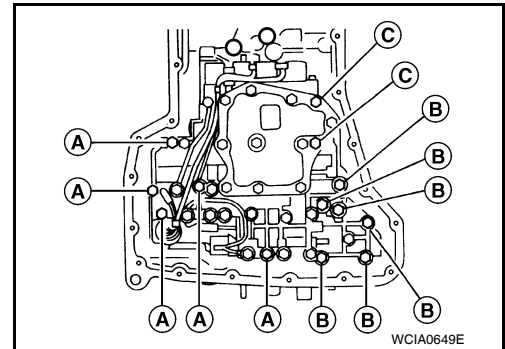

11. Remove control valve assembly from transaxle case.

CAUTION:

Be careful not to drop manual valve and servo release accumulator return spring.

12. Remove manual valve from control valve assembly.

CAUTION:

Be careful not to drop manual valve.

13. Remove O-ring from terminal body.

14. Disassemble and inspect control valve assembly if necessary. Refer to [AT-281, "Control Valve Assembly"](#), [AT-290, "Control Valve Upper Body"](#) and [AT-294, "Control Valve Lower Body"](#).

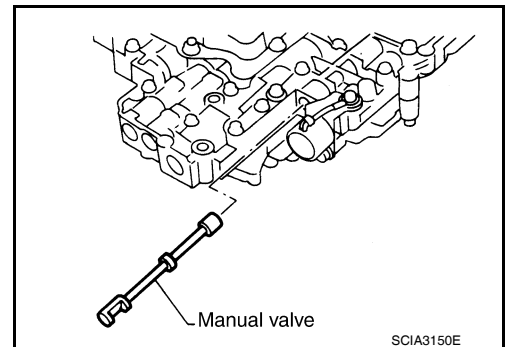

15. Remove servo release accumulator piston and N-D accumulator piston by applying compressed air if necessary.

CAUTION:

Hold each piston with lint-free cloth.

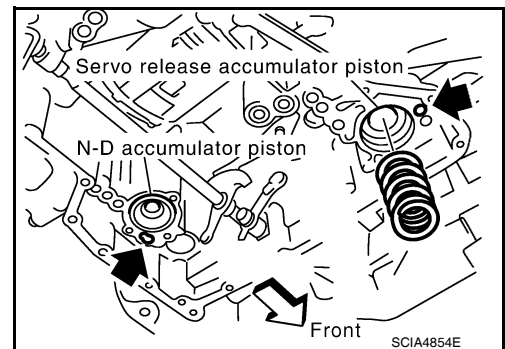

ON-VEHICLE SERVICE

< SERVICE INFORMATION >

- a. Apply compressed air to the oil hole as shown, and remove servo release accumulator piston from transaxle case.

CAUTION:

Strong flow of air will push the accumulator piston out along with a splash of ATF. To avoid this cover the area with lint-free cloth and blow air little by little.

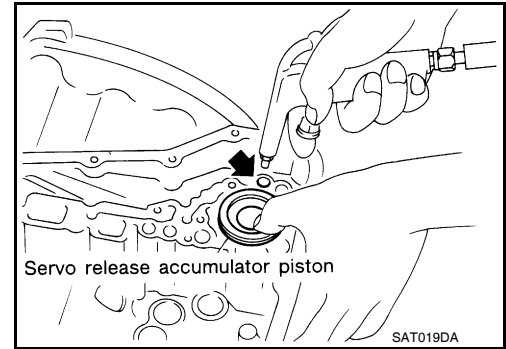

- b. Apply compressed air to the oil hole as shown, and remove N-D accumulator piston and return spring from transaxle case.

CAUTION:

Strong flow of air will push the accumulator piston out along with a splash of ATF. To avoid this cover the area with lint-free cloth and blow air little by little.

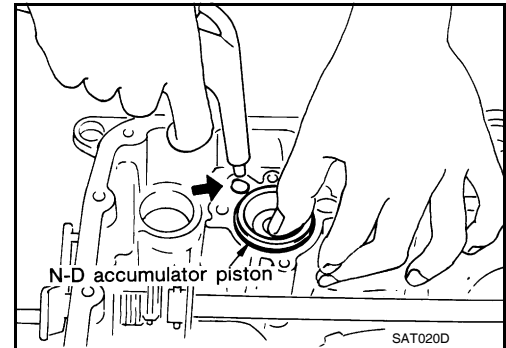

- c. Remove O-rings (1) from servo release accumulator piston (2) and N-D accumulator piston (3).

CAUTION:

Wrap the removed servo release accumulator piston (2) and N-D accumulator piston (3) in a lint-free cloth.

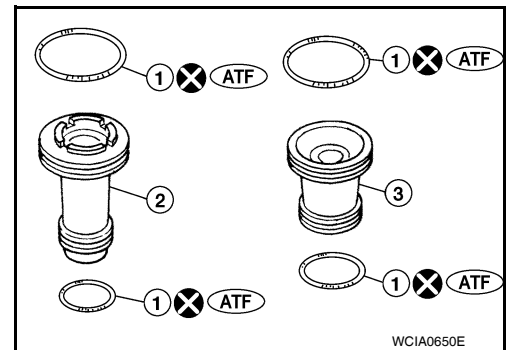

16. Remove lip seals (1) from transaxle case.

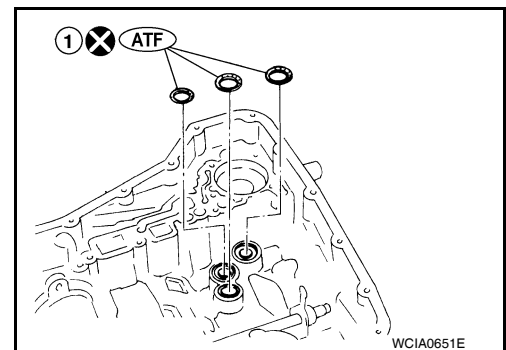

Inspection

- Inspect the sliding surfaces of each accumulator piston and transaxle case, and replace if damaged or dented.
 - (1): Servo release accumulator piston
 - (2): N-D accumulator piston
- Inspect the sliding surfaces of manual valve and valve body, and replace if damaged or dented.

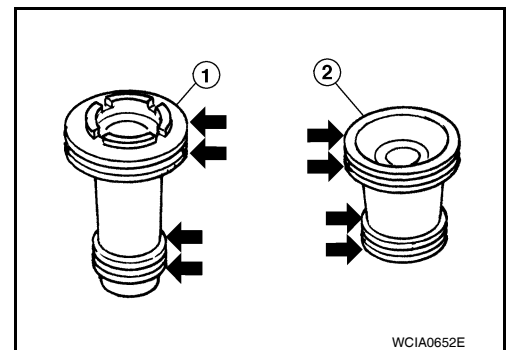

ON-VEHICLE SERVICE

< SERVICE INFORMATION >

- Inspect each return spring, and replace if damaged, deformed or worn. Refer to [AT-376. "Accumulator"](#) for free length (L1) and length (L2).

(1): Return spring (Servo release accumulator)

(2): Return spring (N-D accumulator)

CAUTION:

Do not remove spring retainer (3).

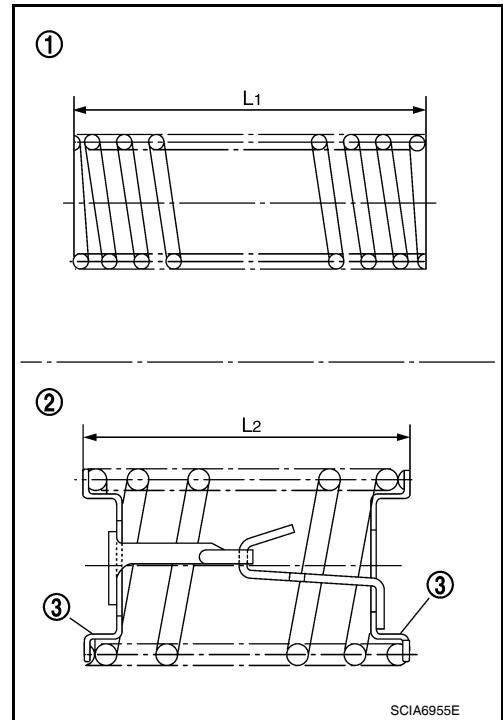

Installation

Installation is in the reverse order of removal.

CAUTION:

- **Completely remove all moisture, oil and old gasket from the oil pan gasket mounting surface of transaxle case and oil pan.**
- **Do not reuse O-rings, lip seals, oil pan gasket and oil pan bolts.**
- **Apply ATF to manual valve, O-rings, lip seals and sliding surfaces of the transaxle case.**

NOTE:

- Set manual shaft in "N" position, then align manual plate (1) with groove in manual valve (2).
- After installing control valve assembly to transaxle case, make sure that shift selector can be moved to all positions.
- After completing installation, check for A/T fluid leakage and A/T fluid level. Refer to [AT-17. "Checking A/T Fluid"](#).

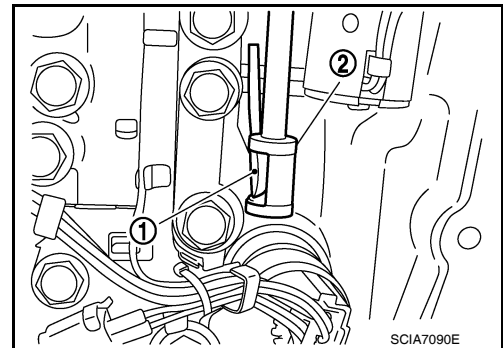

Transmission Range Switch

INFOID:000000005928279

COMPONENTS

A
B
AT
D
E
F
G
H
I
J
K
L
M
N
O
P

ON-VEHICLE SERVICE

< SERVICE INFORMATION >

2. Set shift selector and manual shaft (1) in "N" position.
3. Remove shift selector control cable from manual shaft (1). Refer to [AT-213. "A/T Shift Selector Removal and Installation"](#).
4. Loosen transmission range switch bolts.
←:Bolt
5. Insert the pin (3) [4 mm (0.16 in) dia.] straight into manual shaft (1) adjustment hole.
6. Rotate transmission range switch (2) until the pin (3) can also be inserted straight into hole in transmission range switch (2).
7. Tighten transmission range switch bolts to the specified torque. Refer to "COMPONENTS".
8. Remove the pin (3) from adjustment hole after adjusting transmission range switch (2).
9. Install the shift selector control cable. Refer to [AT-213. "A/T Shift Selector Removal and Installation"](#).
10. Adjust and check A/T position. Refer to [AT-217. "Adjustment of A/T Position"](#) and [AT-217. "Checking of A/T Position"](#).
11. Check continuity of transmission range switch (2). Refer to [AT-175. "Component Inspection"](#).
12. Install the air duct (inlet). Refer to [EM-135](#).

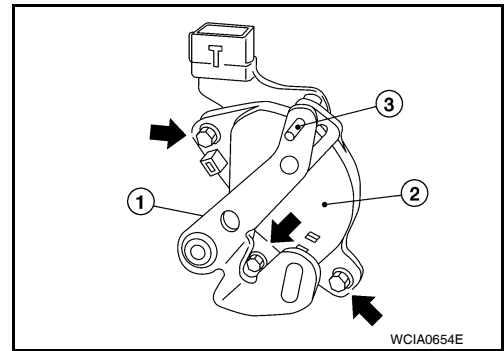

Output Speed Sensor

INFOID:000000005928280

COMPONENTS

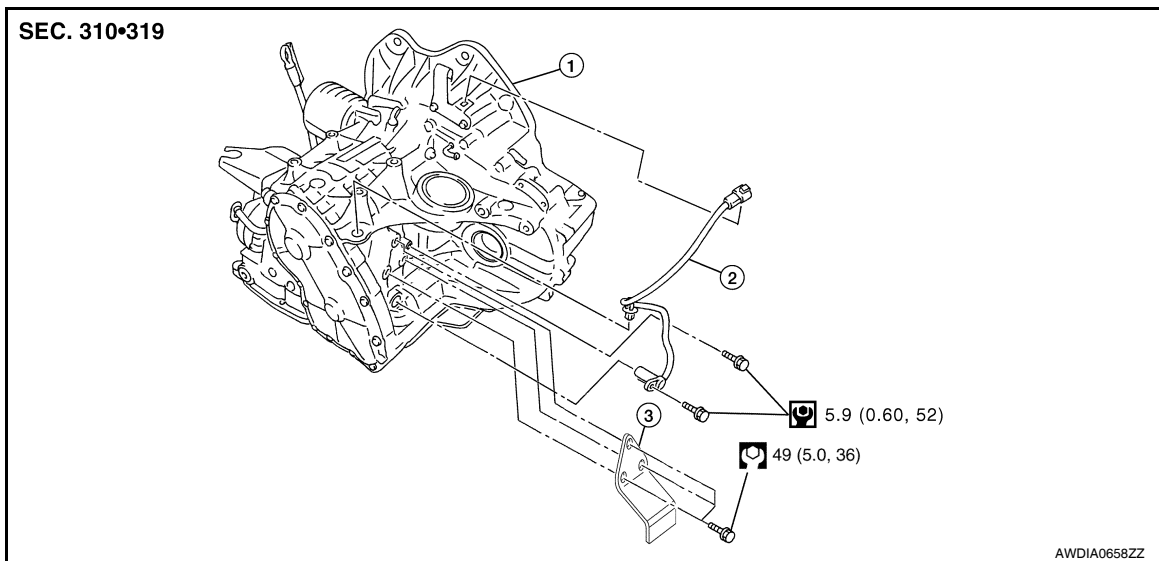

1. A/T

2. Output speed sensor

3. Gusset

REMOVAL AND INSTALLATION

Removal

1. Disconnect the battery negative terminal.
2. Remove air duct (inlet), air duct and air cleaner case. Refer to [EM-135. "Component"](#).

ON-VEHICLE SERVICE

< SERVICE INFORMATION >

3. Remove gusset (1).

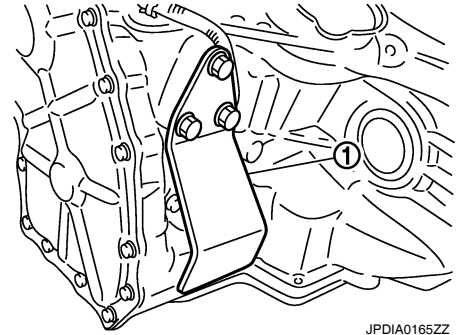

4. Disconnect output speed sensor harness connector.
5. Remove clip (A).
6. Remove output speed sensor (1) from A/T.
←: Bolt
7. Remove O-ring from output speed sensor (1)

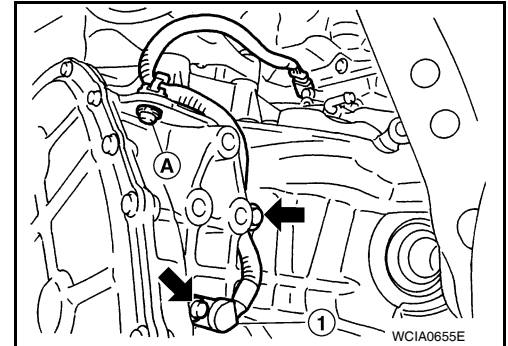

Installation

Installation is in the reverse order of removal.

CAUTION:

- Do not reuse O-ring.
 - Apply ATF to O-ring.
 - Ensure output speed sensor harness is firmly secured with bolt.
- (1): Output speed sensor
←: Bolt

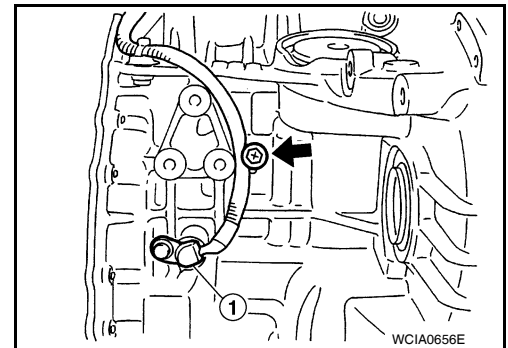

Input Speed Sensor

COMPONENTS

INFOID:000000005928281

ON-VEHICLE SERVICE

< SERVICE INFORMATION >

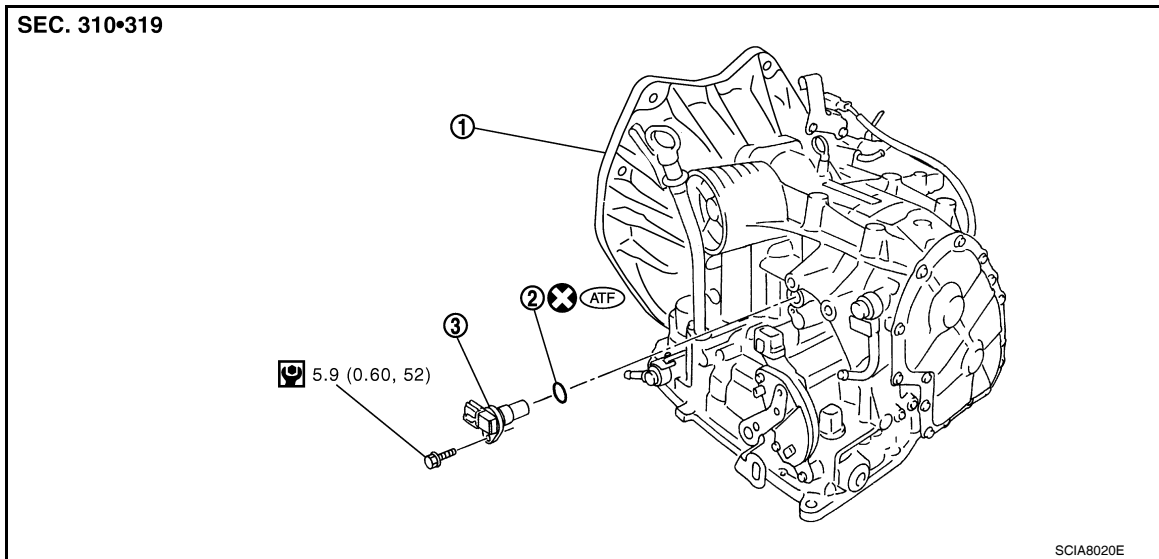

1. A/T 2. O-ring 3. Input speed sensor

REMOVAL AND INSTALLATION

Removal

1. Disconnect the battery negative terminal.
2. Remove air duct (inlet). Refer to [EM-135](#).
3. Disconnect input speed sensor harness connector (1).
4. Remove input speed sensor bolt.
←: Bolt
5. Remove input speed sensor (2) from A/T.
6. Remove O-ring from input speed sensor (2).

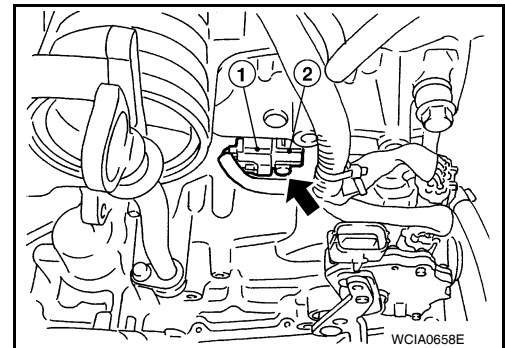

Installation

Installation is in the reverse order of removal.

CAUTION:

- Do not reuse O-ring.
- Apply ATF to O-ring.

Differential Side Oil Seal

INFOID:000000005928282

COMPONENTS

A
B
AT
D
E
F
G
H
I
J
K
L
M
N
O
P

ON-VEHICLE SERVICE

< SERVICE INFORMATION >

- After installing differential side oil seal, check A/T fluid leakage and A/T fluid level. Refer to [AT-17. "Checking A/T Fluid"](#).

A

B

AT

D

E

F

G

H

I

J

K

L

M

N

O

P

AIR BREATHER HOSE

< SERVICE INFORMATION >

AIR BREATHER HOSE

Removal and Installation

INFOID:000000005928283

COMPONENTS

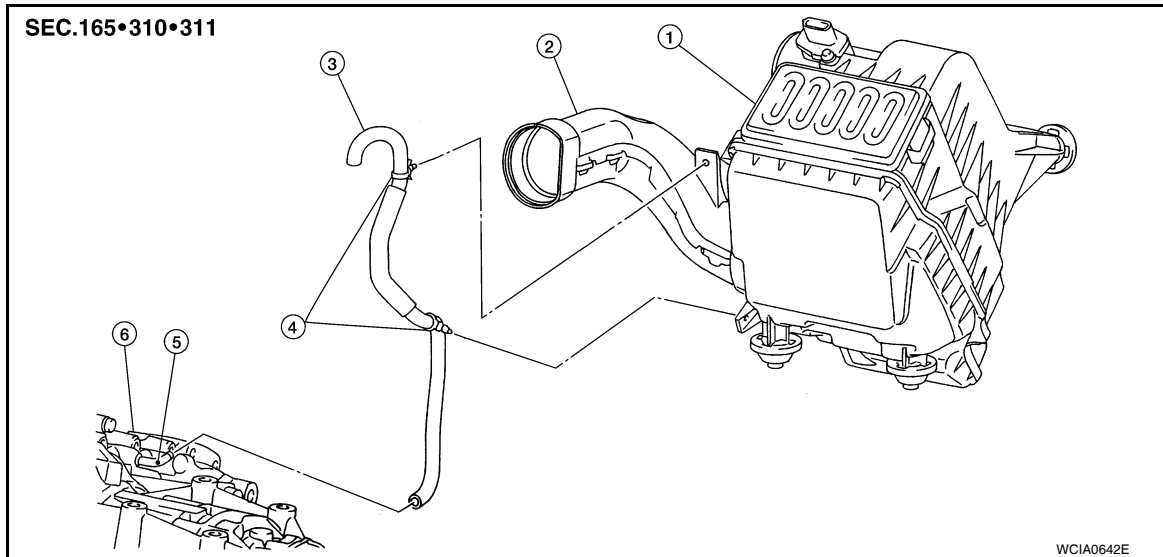

- | | | |
|---------------------|----------------------|----------------------|
| 1. Air cleaner case | 2. Air duct (inlet) | 3. Air breather hose |
| 4. Clip | 5. Air breather tube | 6. A/T |

REMOVAL

1. Remove air duct (front), air duct (inlet) and air cleaner case. Refer to [EM-135](#).
2. Remove air breather hose.

INSTALLATION

Installation is in the reverse order of removal.

CAUTION:

Make sure air breather hose is not collapsed or blocked due to folding or bending when installed.

NOTE:

- Install the air breather hose (1) to the air breather tube (2) so that the paint mark (A) faces upward. Also make sure the air breather hose end laps with air breather tube 17 mm (0.67 in) or more.
- When installing air breather hose (1) to air duct and air cleaner case, make sure to fully insert the hose clips.

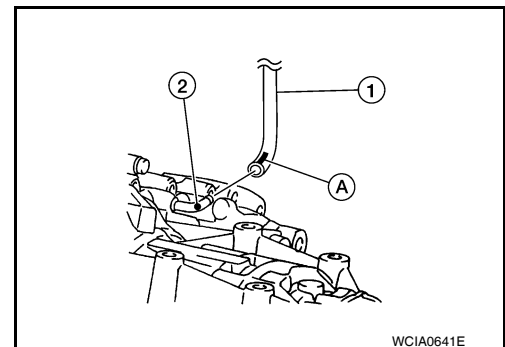

TRANSAXLE ASSEMBLY

< SERVICE INFORMATION >

TRANSAXLE ASSEMBLY

Removal and Installation

INFOID:000000005928284

COMPONENTS

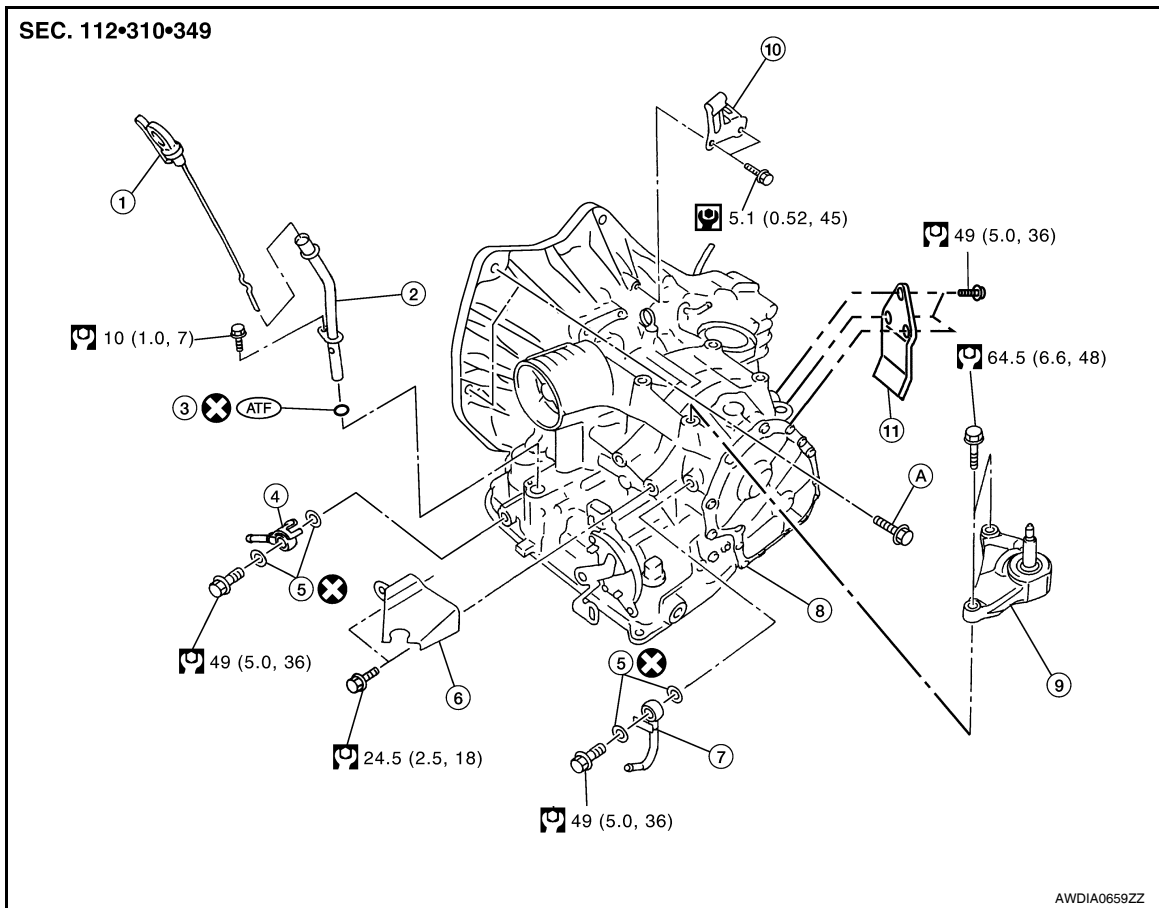

- | | | |
|--------------------------|----------------------------|---------------------------------|
| 1. A/T fluid level gauge | 2. A/T fluid charging pipe | 3. O-ring |
| 4. Fluid cooler tube | 5. Copper washer | 6. Bracket |
| 7. Fluid cooler tube | 8. A/T assembly | 9. Engine mounting bracket (LH) |
| 10. Bracket | 11. Gusset | A. Refer to "INSTALLATION". |

REMOVAL

1. Remove the engine and transaxle as an assembly. Refer to [EM-197, "Removal and Installation"](#).

TRANSAXLE ASSEMBLY

< SERVICE INFORMATION >

2. Disconnect the following connectors and remove the wire harness.
 - Input speed sensor harness connector (1)
 - Terminal cord assembly harness connector (2)
 - Transmission range switch connector (3)
 - output speed sensor harness connector (4)

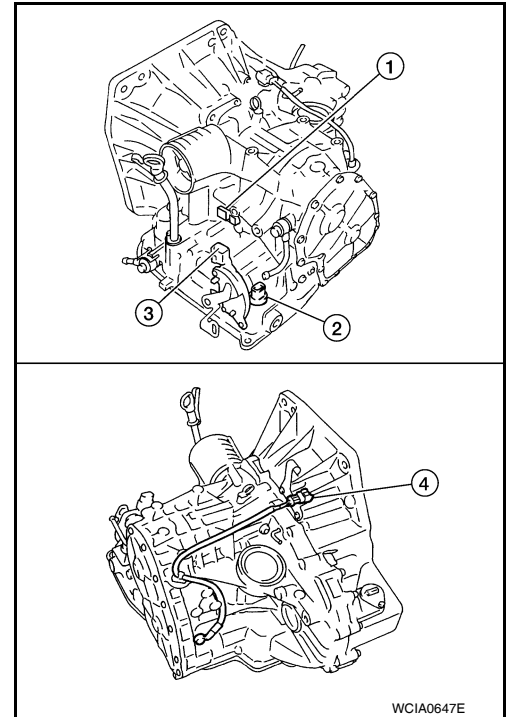

3. Remove the four drive plate to torque converter bolts.
NOTE:
Rotate the crankshaft clockwise as viewed from front of engine for access to drive plate to torque converter bolts.

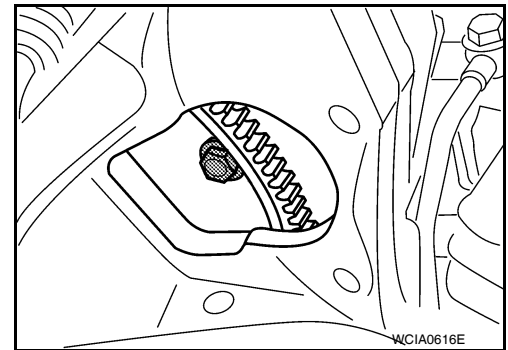

4. Put matching marks on the drive plate and torque converter.
CAUTION:
For matching marks, use paint. Never damage the drive plate or torque converter.
5. Remove the transaxle to engine and engine to transaxle bolts.
6. Separate the transaxle from the engine.
CAUTION:
Secure torque converter to prevent it from dropping.
7. If necessary, remove the following from the transaxle:
 - output speed sensor
 - Input speed sensor
 - Fluid cooler tubes (1) and copper washers
 - A/T fluid level gauge (2) and charging pipe (3)
 - Transmission range switch
 - Air breather hose
 - Engine mounting bracket (LH)
 - Any necessary brackets

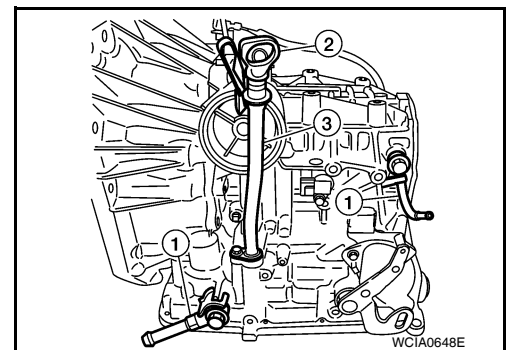

INSTALLATION

Installation is in the reverse order of removal.

CAUTION:

TRANSAXLE ASSEMBLY

< SERVICE INFORMATION >

- When replacing an engine or transmission you must make sure any dowels are installed correctly during re-assembly.
- Improper alignment caused by missing dowels may cause vibration, oil leaks or breakage of drive train components.
- Do not reuse O-rings and copper washers. Refer to "COMPONENTS".
- When turning crankshaft, turn it clockwise as viewed from the front of the engine.
- When tightening the bolts for the torque converter while securing the crankshaft pulley bolt, be sure to confirm the tightening torque of the crankshaft pulley bolt. Refer to [EM-159](#).
- After converter is installed to drive plate, rotate crankshaft several turns to check that transaxle rotates freely without binding.
- When installing the torque converter to the transaxle measure distance A.

Dimension A: 14.4 mm (0.567 in) or more

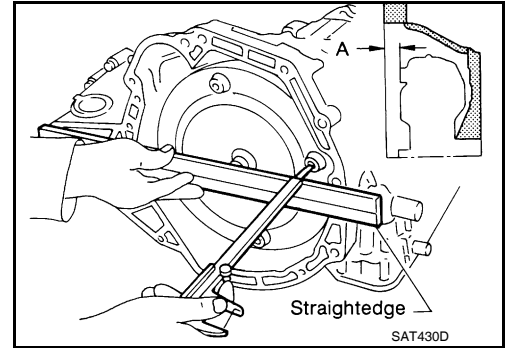

- Check the fitting of the dowel pins when installing the transaxle assembly and the engine assembly.

←: Dowel pin

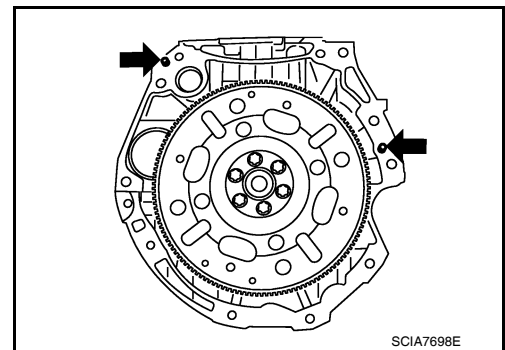

- When installing the transaxle to the engine, align the matching mark on the drive plate with the matching mark on the torque converter.
- When securing the transaxle to the engine, attach the bolts in accordance with the following standard.

HR16DE engine models

Bolt No.	1	2	3	4
Number of bolts	2	2	1	3
Bolt length (L) [mm (in)]	40 (1.57)	44 (1.73)	69 (2.72)	49 (1.93)
Tightening torque [N·m (kg-m, ft-lb)]	48 (4.9, 35)			

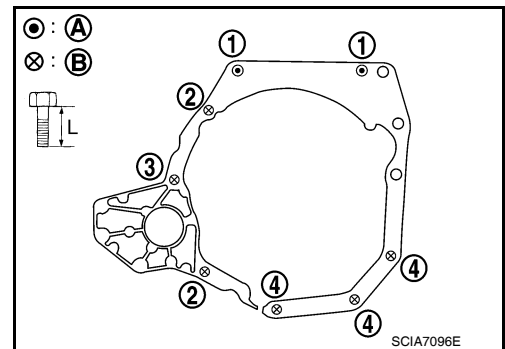

(A): A/T to engine
(B): Engine to A/T

- When installing the transaxle to the engine, align the matching mark on the drive plate with the matching mark on the torque converter.
- When securing the transaxle to the engine, attach the bolts in accordance with the following standard.

TRANSAXLE ASSEMBLY

< SERVICE INFORMATION >

MR18DE engine models		
Bolt No.	1	2
Number of bolts	2	7
Bolt length "L" [mm (in)]	55 (2.17)	50 (1.97)
Tightening torque [N·m (kg-m, ft-lb)]	62 (6.3, 46)	

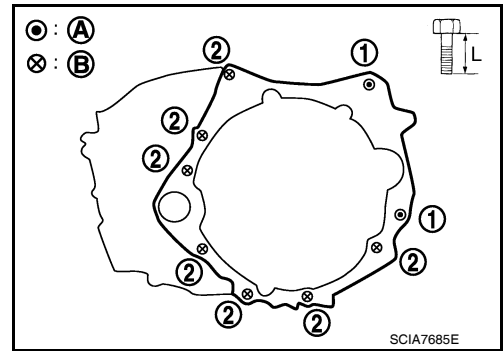

(A): A/T to engine
(B): Engine to A/T

- Align the positions for the bolts on drive plate with those of the torque converter, and temporarily tighten bolts. Then, tighten bolts to the specified torque.

Converter nuts : 51 N·m (5.2 kg-m, 38 ft-lb)

- After completing installation, check for A/T fluid leakage, A/T fluid level and A/T positions. Refer to [AT-17, "Checking A/T Fluid"](#) and [AT-217, "Checking of A/T Position"](#).

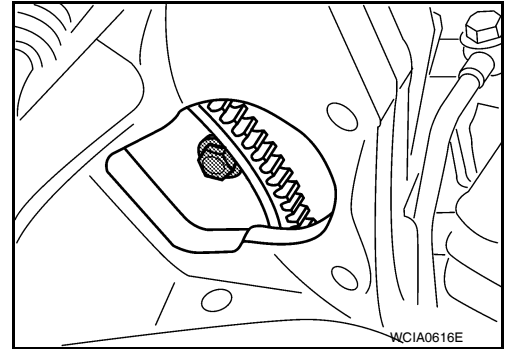

OVERHAUL

< SERVICE INFORMATION >

OVERHAUL

Component

INFOID:000000005928285

HR16DE ENGINE MODELS

With ABS

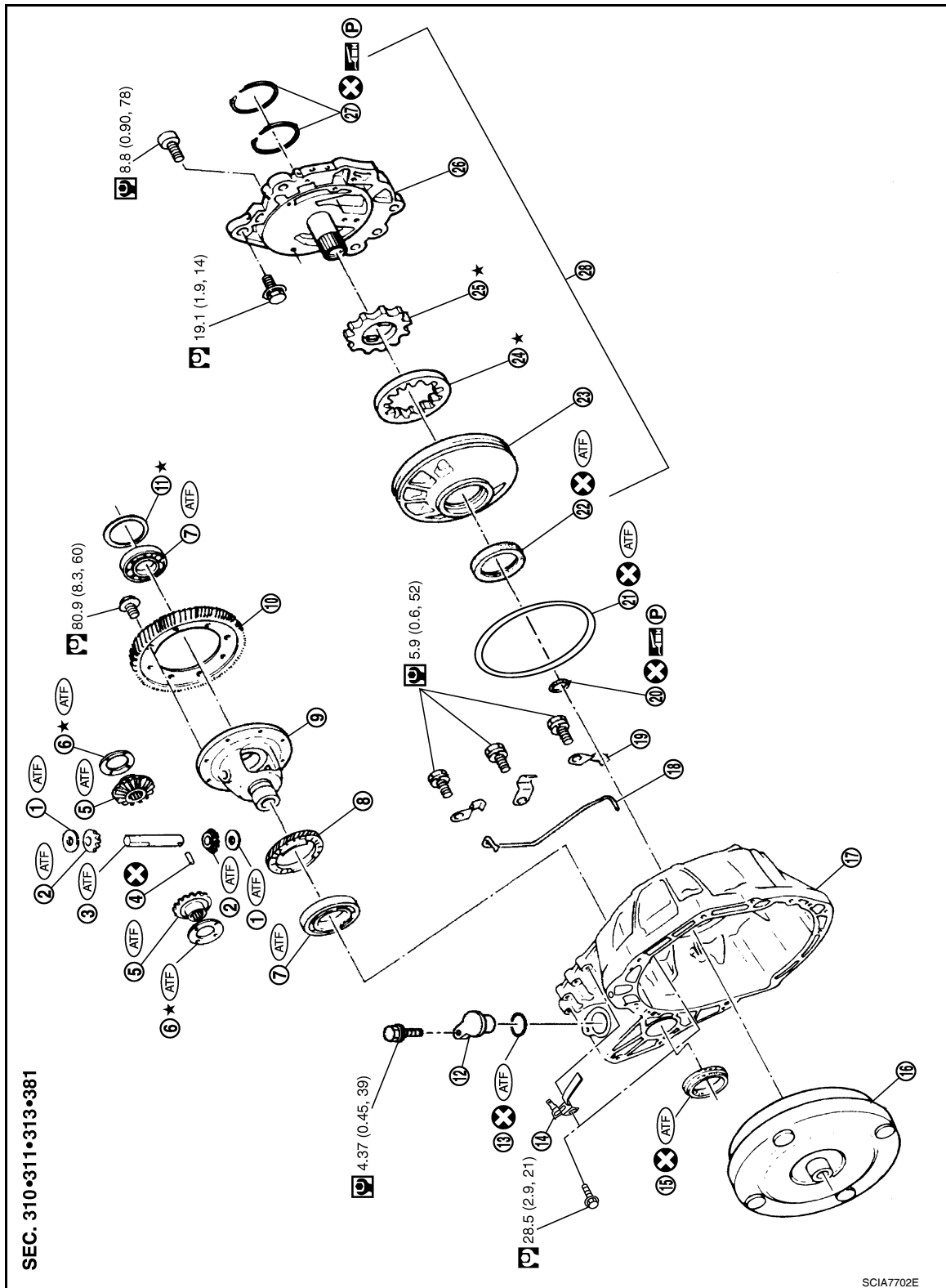

A

B

AT

D

E

F

G

H

I

J

K

L

M

N

O

P

OVERHAUL

< SERVICE INFORMATION >

- | | | |
|-----------------------------------|--|-----------------------------------|
| 1. Pinion mate gear thrust washer | 2. Pinion mate gear | 3. Pinion mate shaft |
| 4. Lock pin | 5. Side gear | 6. Side gear thrust washer |
| 7. Differential side bearing | 8. Speedometer drive gear | 9. Differential case |
| 10. Final gear | 11. Differential side bearing adjusting shim | 12. Plug |
| 13. O-ring | 14. Bracket | 15. RH differential side oil seal |
| 16. Torque converter | 17. Converter housing | 18. Differential lubricant tube |
| 19. Clip | 20. O-ring | 21. O-ring |
| 22. Oil pump housing oil seal | 23. Oil pump housing | 24. Outer gear |
| 25. Inner gear | 26. Oil pump cover | 27. Seal ring |
| 28. Oil pump assembly | | |

OVERHAUL

< SERVICE INFORMATION >

Without ABS

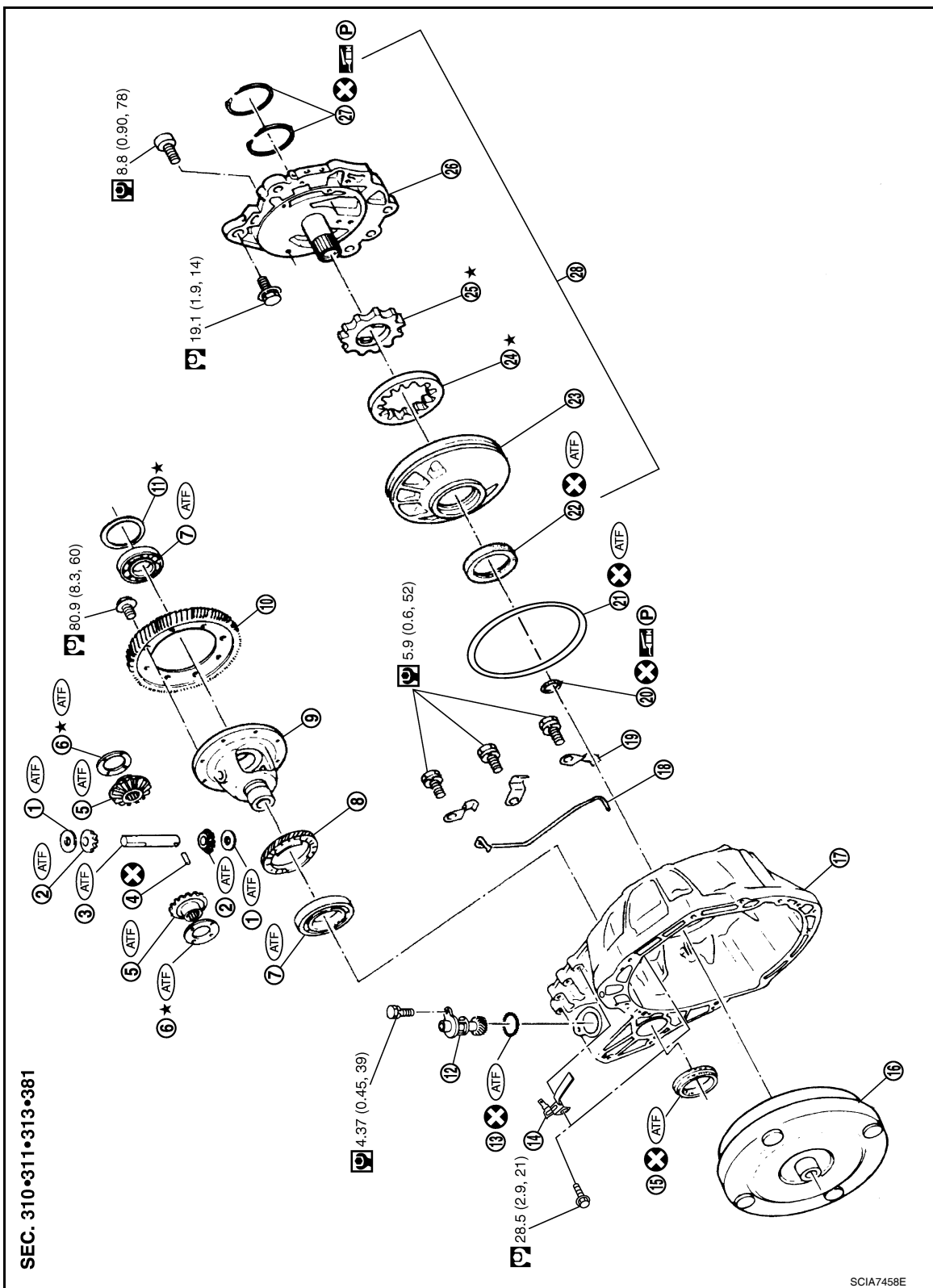

- | | | |
|-----------------------------------|--|-----------------------------------|
| 1. Pinion mate gear thrust washer | 2. Pinion mate gear | 3. Pinion mate shaft |
| 4. Lock pin | 5. Side gear | 6. Side gear thrust washer |
| 7. Differential side bearing | 8. Speedometer drive gear | 9. Differential case |
| 10. Final gear | 11. Differential side bearing adjusting shim | 12. Speedometer pinion |
| 13. O-ring | 14. Bracket | 15. RH differential side oil seal |
| 16. Torque converter | 17. Converter housing | 18. Differential lubricant tube |

A
B
AT
D
E
F
G
H
I
J
K
L
M
N
O
P

OVERHAUL

< SERVICE INFORMATION >

- | | | |
|-------------------------------|----------------------|----------------|
| 19. Clip | 20. O-ring | 21. O-ring |
| 22. Oil pump housing oil seal | 23. Oil pump housing | 24. Outer gear |
| 25. Inner gear | 26. Oil pump cover | 27. Seal ring |
| 28. Oil pump assembly | | |

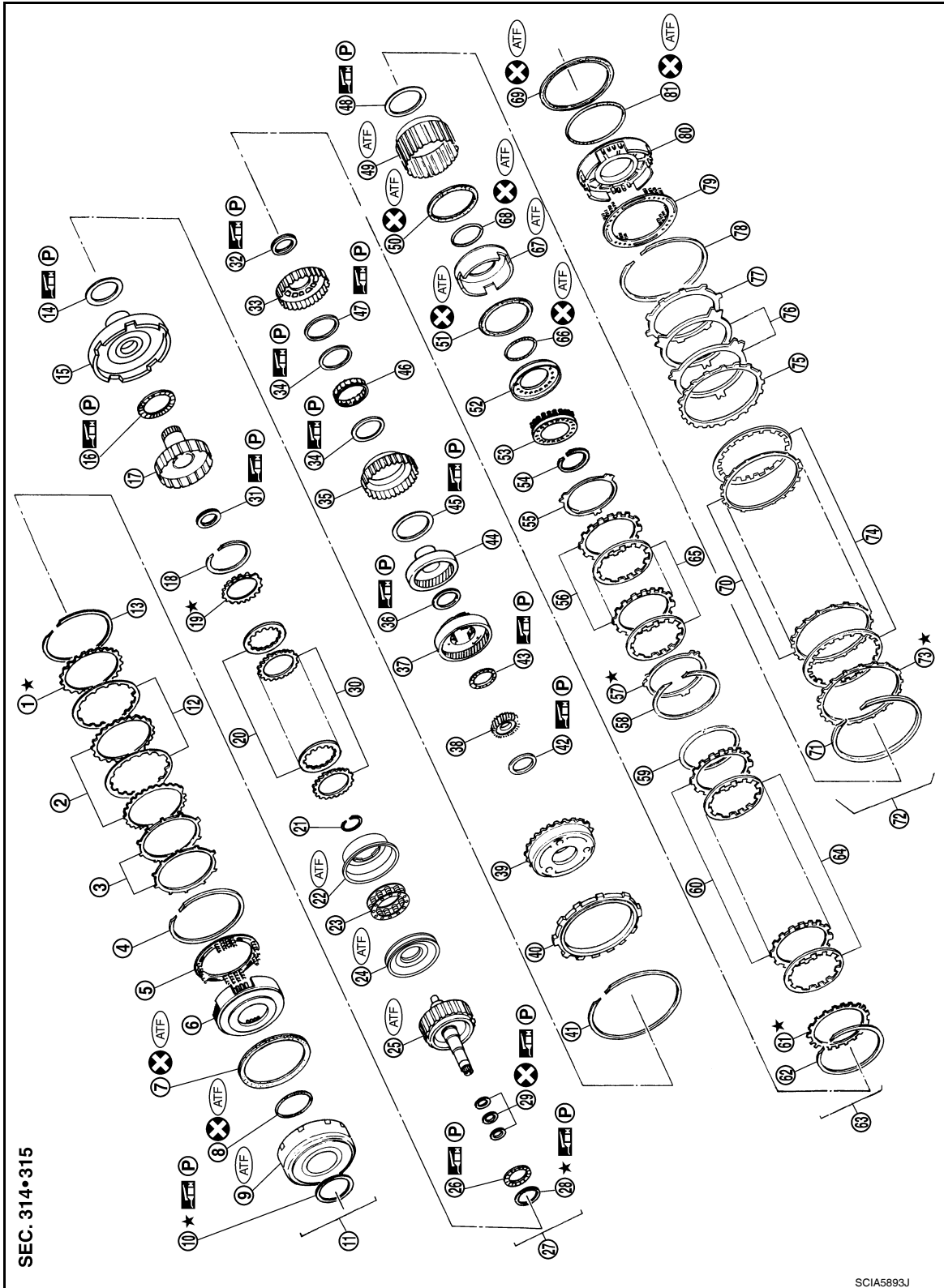

- | | | |
|--------------------|-----------------------------|--------------------------|
| 1. Retaining plate | 2. Driven plate | 3. Dish plate |
| 4. Snap ring | 5. Spring retainer assembly | 6. Reverse clutch piston |

OVERHAUL

< SERVICE INFORMATION >

7. Seal lip	8. D-ring	9. Reverse clutch drum	A
10. Thrust washer	11. Reverse clutch assembly	12. Drive plate	B
13. Snap ring	14. Needle bearing	15. Front sun gear	B
16. Needle bearing	17. High clutch hub	18. Snap ring	B
19. Retaining plate	20. Drive plate	21. Snap ring	B
22. Cancel cover	23. Spring retainer assembly	24. High clutch piston	B
25. Input shaft assembly (high clutch drum)	26. Needle bearing	27. High clutch assembly	AT
28. Bearing race	29. Seal ring	30. Driven plate	
31. Needle bearing	32. Needle bearing	33. Overrun clutch hub	D
34. End bearing	35. Forward clutch hub	36. Needle bearing	D
37. Rear planetary carrier	38. Rear sun gear	39. Front planetary carrier	
40. Low one-way clutch	41. Snap ring	42. Needle bearing	E
43. Needle bearing	44. Rear internal gear	45. Thrust washer	E
46. Forward one-way clutch	47. Thrust washer	48. Thrust washer	
49. Forward clutch drum	50. Seal ring	51. Seal ring	F
52. Overrun clutch piston	53. Spring retainer assembly	54. Snap ring	F
55. Dish plate	56. Driven plate	57. Retaining plate	
58. Snap ring	59. Dish plate	60. Driven plate	G
61. Retaining plate	62. Snap ring	63. Forward clutch assembly and over-run clutch assembly	G
64. Drive plate	65. Drive plate	66. D-ring	H
67. Forward clutch piston	68. D-ring	69. Seal ring	H
70. Driven plate	71. Snap ring	72. Low & reverse brake assembly	
73. Retaining plate	74. Drive plate	75. Retaining plate	I
76. Dish plate	77. Driven plate	78. Snap ring	I
79. Spring retainer assembly	80. Low & reverse brake piston	81. D-ring	J
			J
			K
			K
			L
			L
			M
			M
			N
			N
			O
			O
			P
			P

OVERHAUL

< SERVICE INFORMATION >

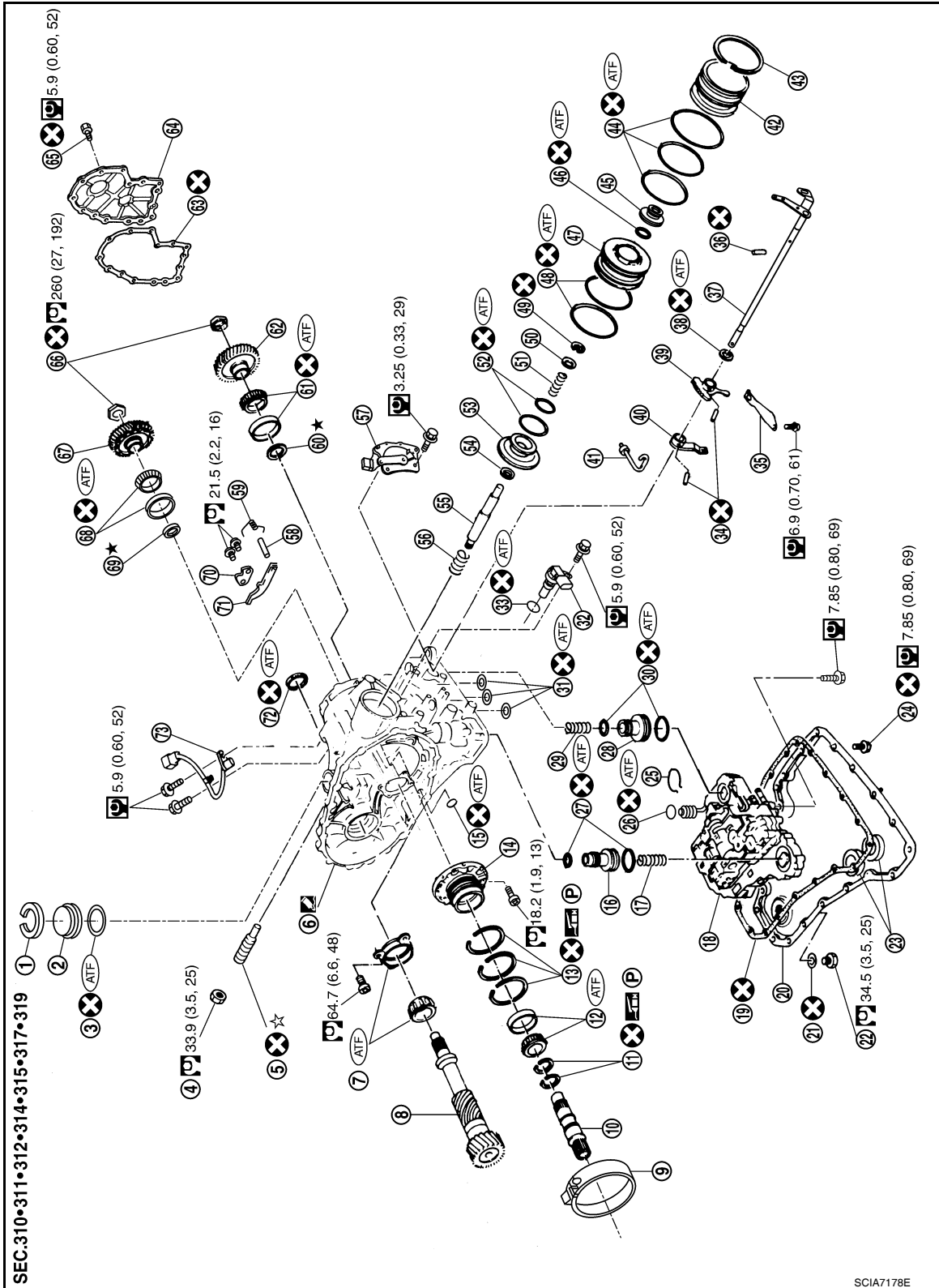

- | | | |
|----------------------------------|--------------------------|--------------------------|
| 1. Snap ring | 2. Governor cap | 3. O-ring |
| 4. Lock nut | 5. Anchor end pin | 6. Transaxle case |
| 7. Reduction pinion gear bearing | 8. Reduction pinion gear | 9. Brake band |
| 10. Output shaft | 11. Seal ring | 12. Output shaft bearing |
| 13. Seal ring | 14. Bearing retainer | 15. O-ring |

OVERHAUL

< SERVICE INFORMATION >

- | | | | |
|--------------------------------------|--------------------------------------|--|----|
| 16. Servo release accumulator piston | 17. Return spring | 18. Control valve assembly | A |
| 19. Oil pan gasket | 20. Oil pan | 21. Drain plug gasket | |
| 22. Drain plug | 23. Magnet | 24. Oil pan bolt | B |
| 25. Snap ring | 26. O-ring | 27. O-ring | |
| 28. N-D accumulator piston | 29. Return spring | 30. O-ring | |
| 31. Lip seal | 32. Input speed sensor | 33. O-ring | AT |
| 34. Retaining pin | 35. Detent spring | 36. Retaining pin | |
| 37. Manual shaft | 38. Manual shaft oil seal | 39. Manual plate | |
| 40. Parking rod plate | 41. Parking rod | 42. OD servo piston retainer | D |
| 43. Snap ring | 44. O-ring | 45. OD servo piston | |
| 46. D-ring | 47. Servo release accumulator piston | 48. O-ring | |
| 49. E-ring | 50. Spring retainer | 51. OD servo return spring | E |
| 52. D-ring | 53. Band servo piston | 54. Band servo thrust washer | |
| 55. Band servo piston stem | 56. 2nd servo return spring | 57. Transmission range switch | |
| 58. Parking shaft | 59. Return spring | 60. Output gear adjusting spacer | F |
| 61. Output gear bearing | 62. Output gear | 63. Side cover gasket | |
| 64. Side cover | 65. Side cover bolt | 66. Lock nut | |
| 67. Idler gear | 68. Idler gear bearing | 69. Reduction pinion gear adjusting shim | G |
| 70. Parking actuator support | 71. Parking pawl | 72. LH differential side oil seal | H |
| 73. Output speed sensor | | | |



Apply Genuine Anaerobic Liquid Gasket or equivalent.

MR18DE ENGINE MODELS

OVERHAUL

< SERVICE INFORMATION >

With ABS

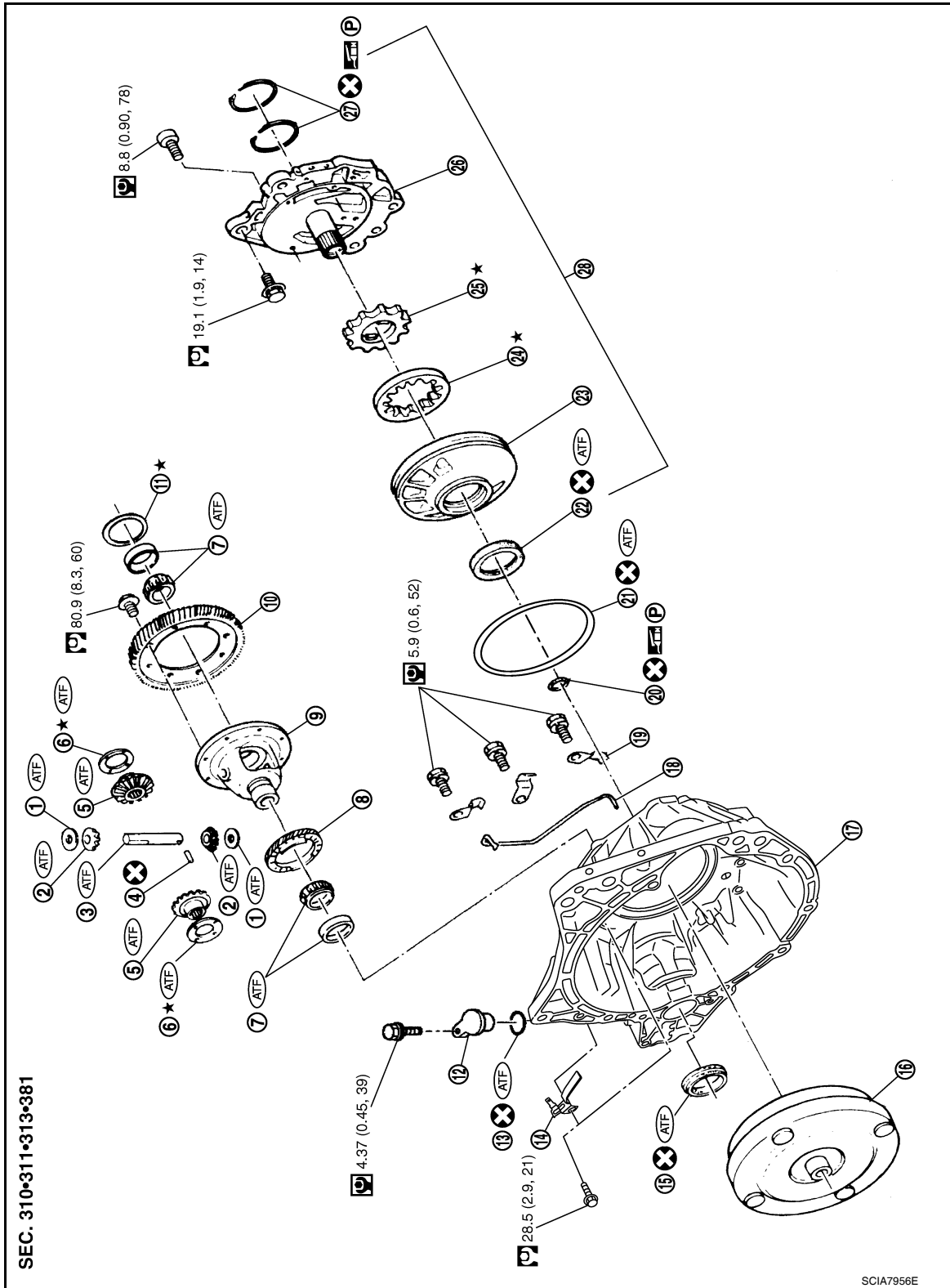

- | | | |
|-----------------------------------|--|-----------------------------------|
| 1. Pinion mate gear thrust washer | 2. Pinion mate gear | 3. Pinion mate shaft |
| 4. Lock pin | 5. Side gear | 6. Side gear thrust washer |
| 7. Differential side bearing | 8. Speedometer drive gear | 9. Differential case |
| 10. Final gear | 11. Differential side bearing adjusting shim | 12. Plug |
| 13. O-ring | 14. Bracket | 15. RH differential side oil seal |
| 16. Torque converter | 17. Converter housing | 18. Differential lubricant tube |

OVERHAUL

< SERVICE INFORMATION >

- | | | |
|-------------------------------|----------------------|----------------|
| 19. Clip | 20. O-ring | 21. O-ring |
| 22. Oil pump housing oil seal | 23. Oil pump housing | 24. Outer gear |
| 25. Inner gear | 26. Oil pump cover | 27. Seal ring |
| 28. Oil pump assembly | | |

Without ABS

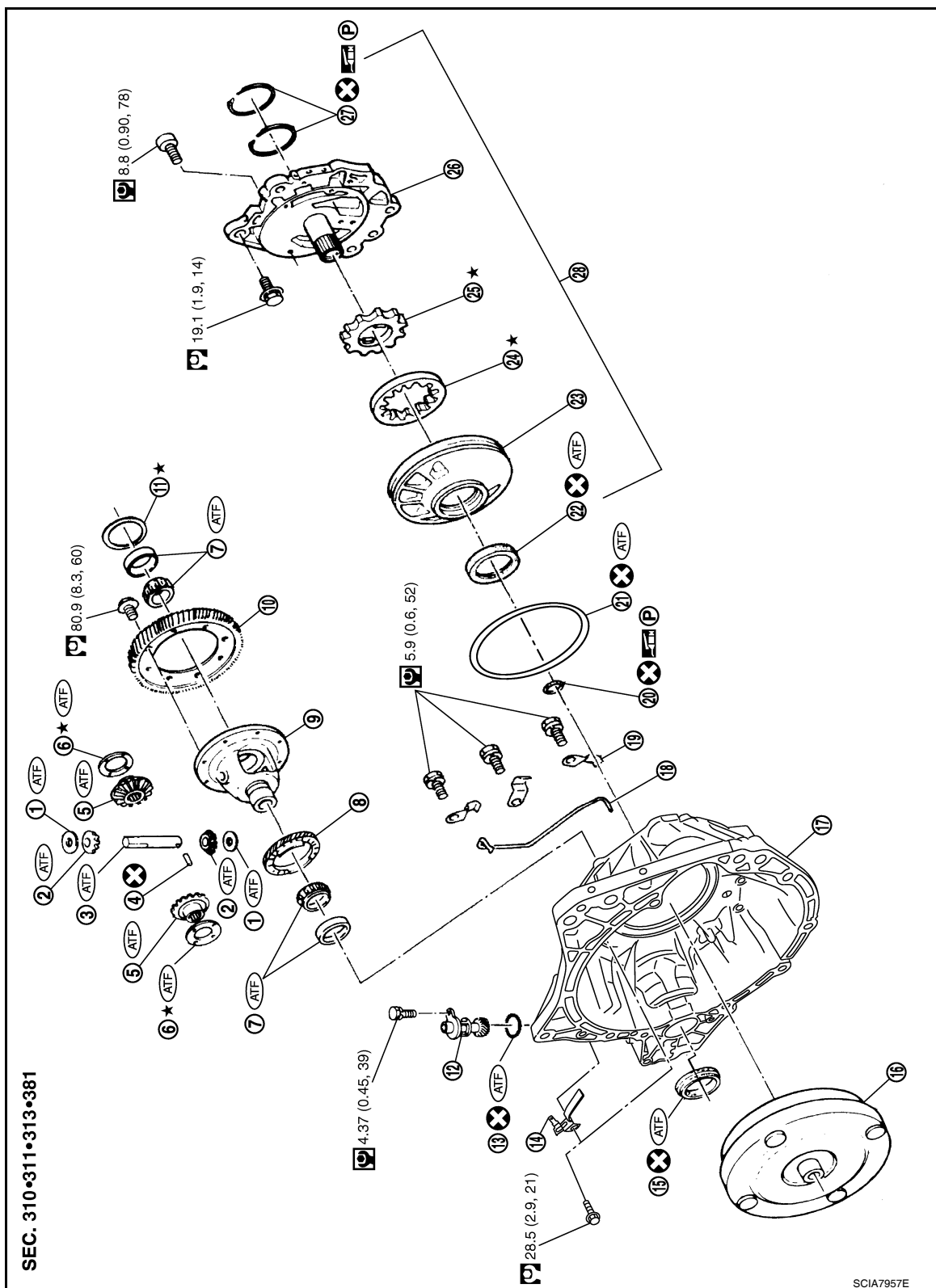

- | | | |
|-----------------------------------|---------------------|----------------------------|
| 1. Pinion mate gear thrust washer | 2. Pinion mate gear | 3. Pinion mate shaft |
| 4. Lock pin | 5. Side gear | 6. Side gear thrust washer |

A
B
AT
D
E
F
G
H
I
J
K
L
M
N
O
P

OVERHAUL

< SERVICE INFORMATION >

- | | | |
|-------------------------------|--|-----------------------------------|
| 7. Differential side bearing | 8. Speedometer drive gear | 9. Differential case |
| 10. Final gear | 11. Differential side bearing adjusting shim | 12. Speedometer pinion |
| 13. O-ring | 14. Bracket | 15. RH differential side oil seal |
| 16. Torque converter | 17. Converter housing | 18. Differential lubricant tube |
| 19. Clip | 20. O-ring | 21. O-ring |
| 22. Oil pump housing oil seal | 23. Oil pump housing | 24. Outer gear |
| 25. Inner gear | 26. Oil pump cover | 27. Seal ring |
| 28. Oil pump assembly | | |

OVERHAUL

< SERVICE INFORMATION >

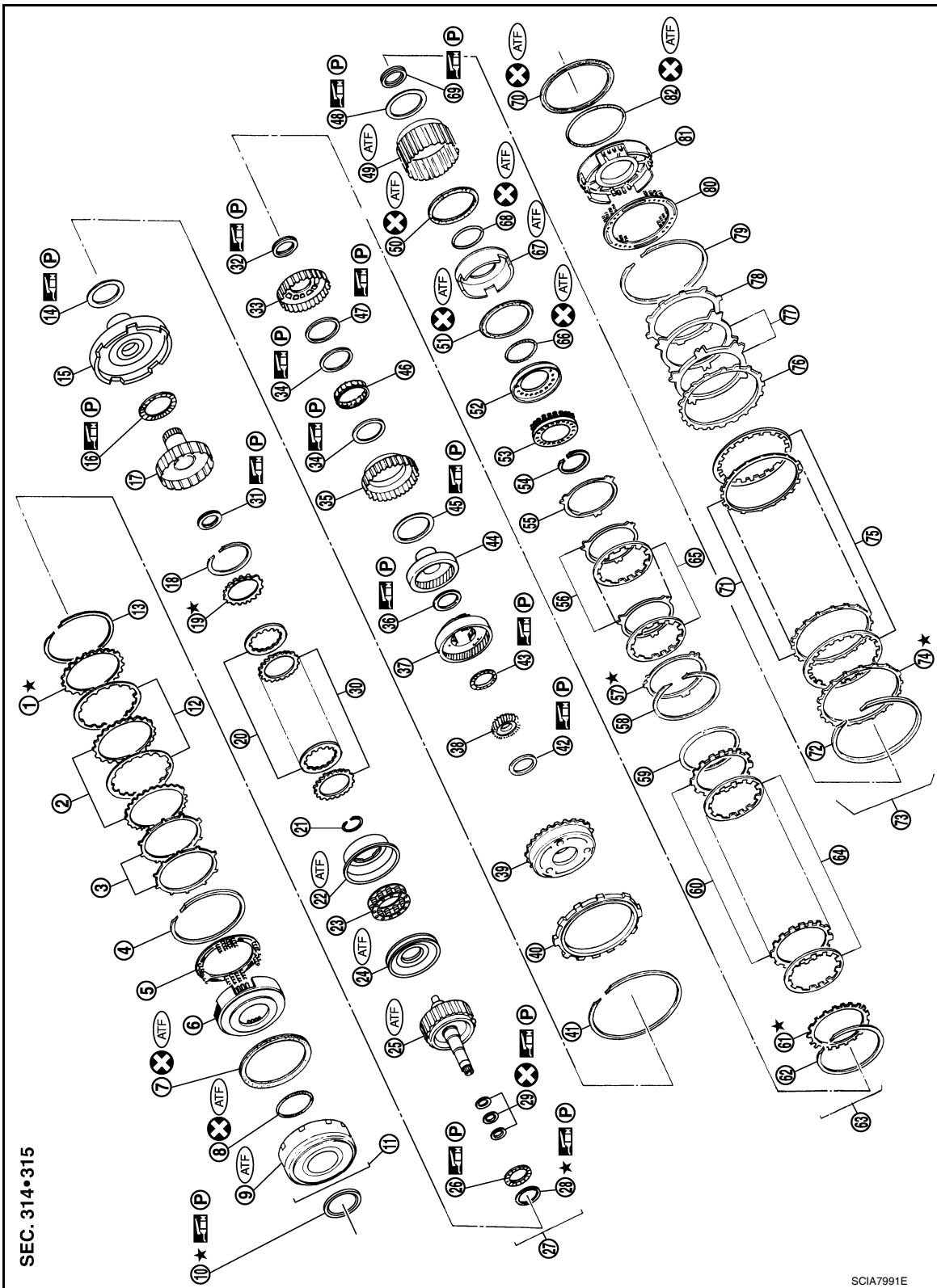

SEC. 314•315

SCIA7991E

- | | | |
|--------------------|-----------------------------|--------------------------|
| 1. Retaining plate | 2. Driven plate | 3. Dish plate |
| 4. Snap ring | 5. Spring retainer assembly | 6. Reverse clutch piston |
| 7. Seal lip | 8. D-ring | 9. Reverse clutch drum |
| 10. Thrust washer | 11. Reverse clutch assembly | 12. Drive plate |
| 13. Snap ring | 14. Needle bearing | 15. Front sun gear |
| 16. Needle bearing | 17. High clutch hub | 18. Snap ring |

A
B
AT
D
E
F
G
H
I
J
K
L
M
N
O
P

OVERHAUL

< SERVICE INFORMATION >

- | | | |
|---|------------------------------|---|
| 19. Retaining plate | 20. Drive plate | 21. Snap ring |
| 22. Cancel cover | 23. Spring retainer assembly | 24. High clutch piston |
| 25. Input shaft assembly (high clutch drum) | 26. Needle bearing | 27. High clutch assembly |
| 28. Bearing race | 29. Seal ring | 30. Driven plate |
| 31. Needle bearing | 32. Needle bearing | 33. Overrun clutch hub |
| 34. End bearing | 35. Forward clutch hub | 36. Needle bearing |
| 37. Rear planetary carrier | 38. Rear sun gear | 39. Front planetary carrier |
| 40. Low one-way clutch | 41. Snap ring | 42. Needle bearing |
| 43. Needle bearing | 44. Rear internal gear | 45. Thrust washer |
| 46. Forward one-way clutch | 47. Thrust washer | 48. Thrust washer |
| 49. Forward clutch drum | 50. Seal lip | 51. Seal lip |
| 52. Overrun clutch piston | 53. Spring retainer assembly | 54. Snap ring |
| 55. Dish plate | 56. Driven plate | 57. Retaining plate |
| 58. Snap ring | 59. Dish plate | 60. Driven plate |
| 61. Retaining plate | 62. Snap ring | 63. Forward clutch assembly and overrun clutch assembly |
| 64. Drive plate | 65. Drive plate | 66. D-ring |
| 67. Forward clutch piston | 68. D-ring | 69. Needle bearing |
| 70. Seal lip | 71. Driven plate | 72. Snap ring |
| 73. Low & reverse brake assembly | 74. Retaining plate | 75. Drive plate |
| 76. Retaining plate | 77. Dish plate | 78. Driven plate |
| 79. Snap ring | 80. Spring retainer assembly | 81. Low & reverse brake piston |
| 82. D-ring | | |

OVERHAUL

< SERVICE INFORMATION >

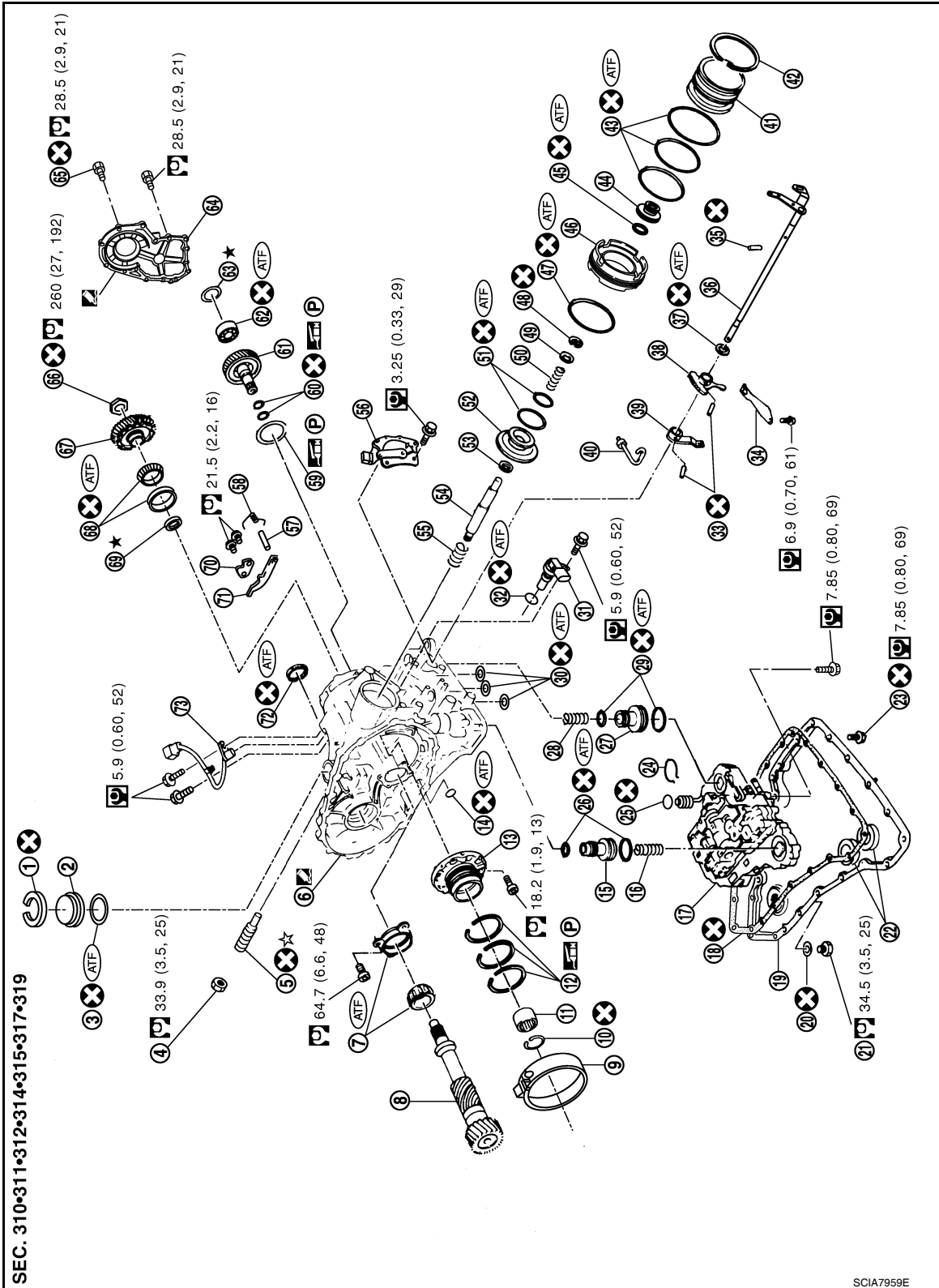

- | | | |
|----------------------------------|----------------------------|--------------------------------------|
| 1. Snap ring | 2. Governor cap | 3. O-ring |
| 4. Lock nut | 5. Anchor end pin | 6. Transaxle case |
| 7. Reduction pinion gear bearing | 8. Reduction pinion gear | 9. Brake band |
| 10. Snap ring | 11. Radial needle bearing | 12. Seal ring |
| 13. Bearing retainer | 14. O-ring | 15. Servo release accumulator piston |
| 16. Return spring | 17. Control valve assembly | 18. Oil pan gasket |

A
B
AT
D
E
F
G
H
I
J
K
L
M
N
O
P

OVERHAUL

< SERVICE INFORMATION >

- | | | |
|------------------------------|-------------------------------|--|
| 19. Oil pan | 20. Drain plug gasket | 21. Drain plug |
| 22. Magnet | 23. Oil pan bolt | 24. Snap ring |
| 25. O-ring | 26. O-ring | 27. N-D accumulator piston |
| 28. Return spring | 29. O-ring | 30. Lip seal |
| 31. Input speed sensor | 32. O-ring | 33. Retaining pin |
| 34. Detent spring | 35. Retaining pin | 36. Manual shaft |
| 37. Manual shaft oil seal | 38. Manual plate | 39. Parking rod plate |
| 40. Parking rod | 41. OD servo piston retainer | 42. Snap ring |
| 43. O-ring | 44. OD servo piston | 45. D-ring |
| 46. Servo piston retainer | 47. O-ring | 48. E-ring |
| 49. Spring retainer | 50. OD servo return spring | 51. D-ring |
| 52. Band servo piston | 53. Band servo thrust washer | 54. Band servo piston stem |
| 55. 2nd servo return spring | 56. Transmission range switch | 57. Parking shaft |
| 58. Return spring | 59. Thrust needle bearing | 60. Seal ring |
| 61. Output shaft | 62. Output shaft bearing | 63. Output shaft adjusting shim |
| 64. Side cover | 65. Side cover bolt | 66. Lock nut |
| 67. Idler gear | 68. Idler gear bearing | 69. Reduction pinion gear adjusting shim |
| 70. Parking actuator support | 71. Parking pawl | 72. LH differential side oil seal |
| 73. Output speed sensor | | |

 Apply Genuine Anaerobic Liquid Gasket or equivalent.

Oil Channel

INFOID:000000005928286

HR16DE ENGINE MODELS

OVERHAUL

< SERVICE INFORMATION >

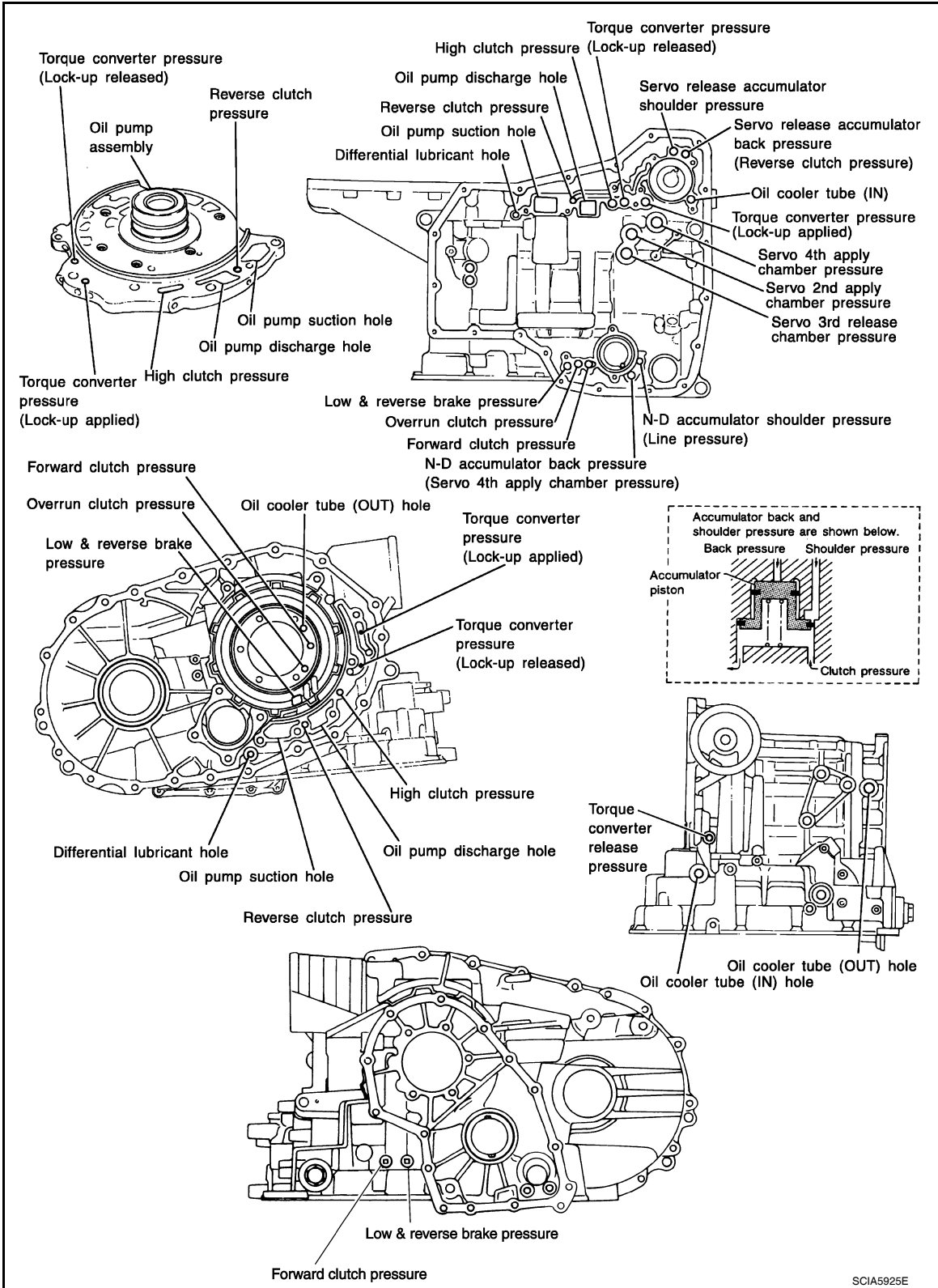

A
B
AT
D
E
F
G
H
I
J
K
L
M
N
O
P

MR18DE ENGINE MODELS

OVERHAUL

< SERVICE INFORMATION >

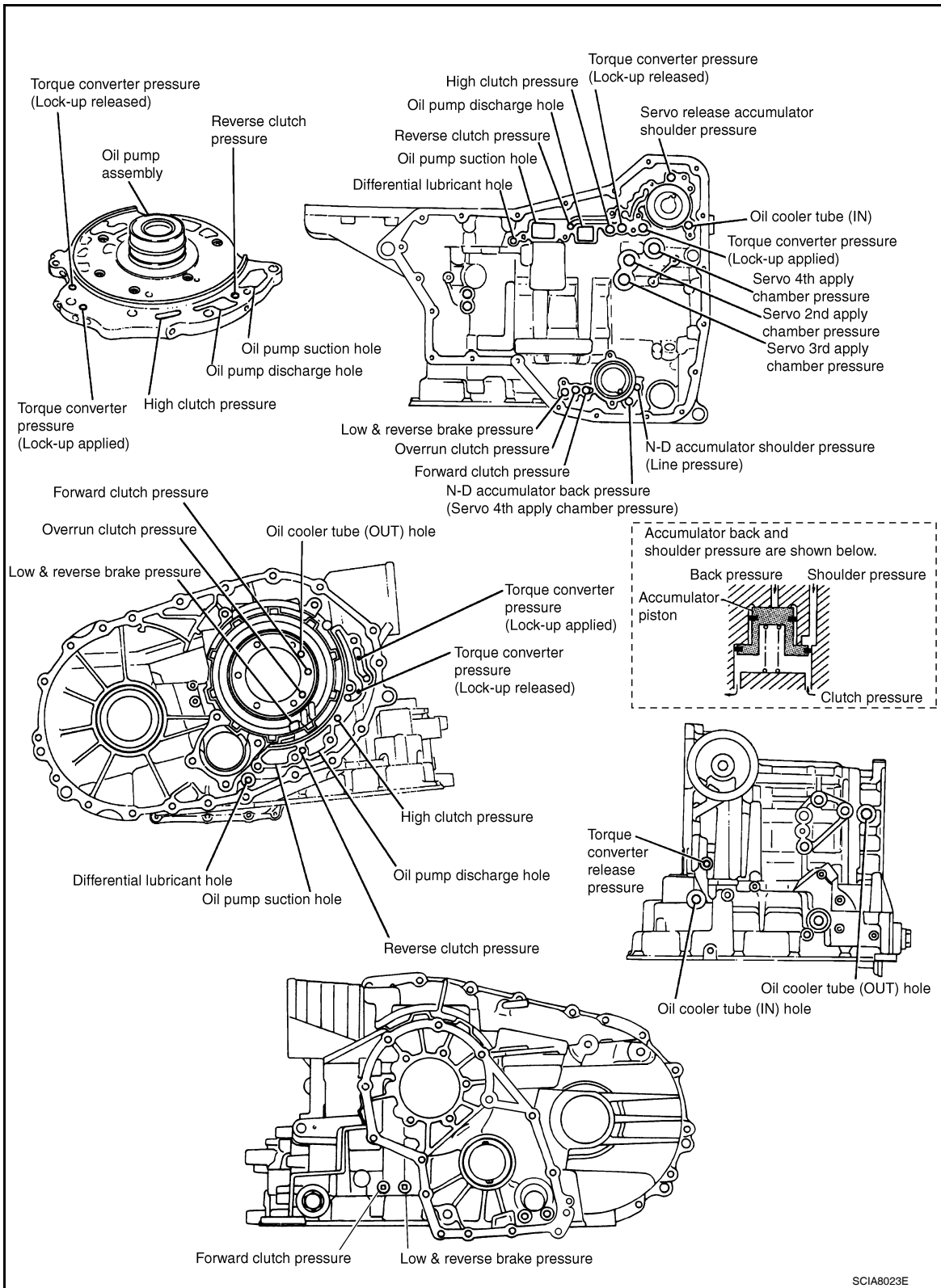

OVERHAUL

< SERVICE INFORMATION >

Location of Adjusting Shims, Needle Bearings and Thrust Washers

INFOID:000000005928287

HR16DE ENGINE MODELS

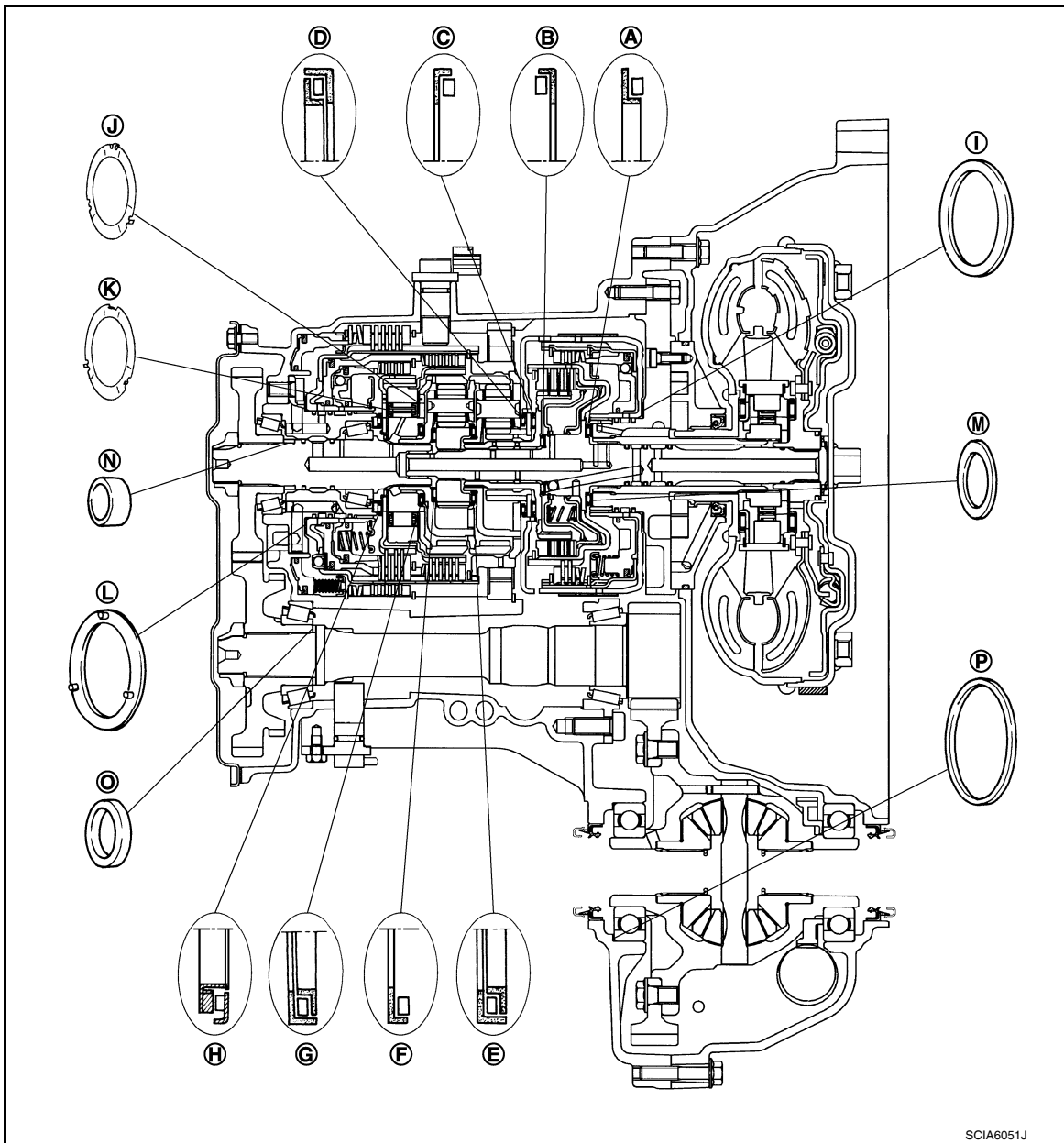

- Refer to [AT-374](#), "Adjusting shims, Needle Bearings, Thrust Washers and Snap Rings".

A
B
AT
D
E
F
G
H
I
J
K
L
M
N
O
P

OVERHAUL

< SERVICE INFORMATION >

MR18DE ENGINE MODELS

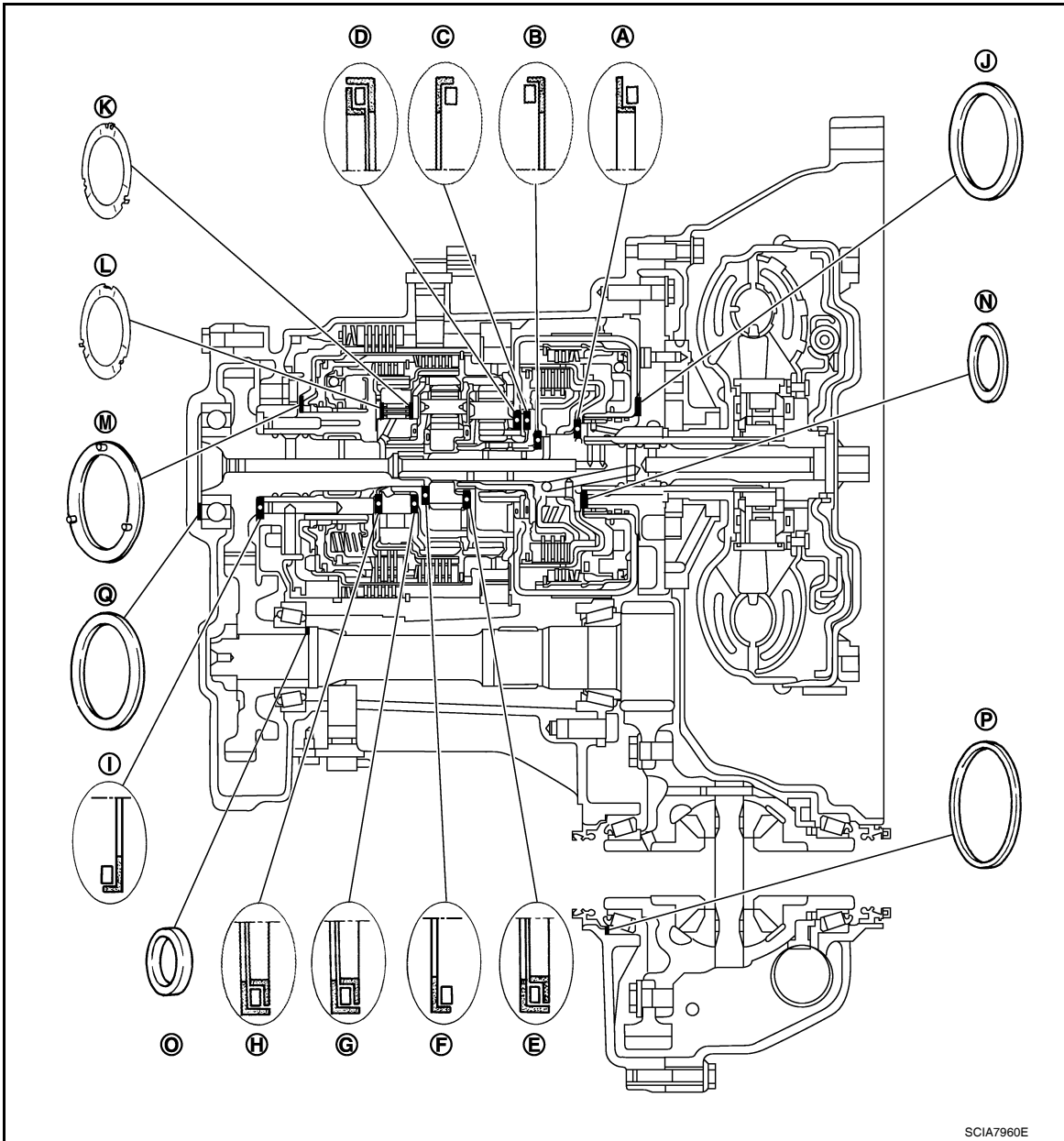

- Refer to [AT-374, "Adjusting shims, Needle Bearings, Thrust Washers and Snap Rings"](#).

OVERHAUL

< SERVICE INFORMATION >

Location of Snap Rings

INFOID:000000005928288

HR16DE ENGINE MODELS

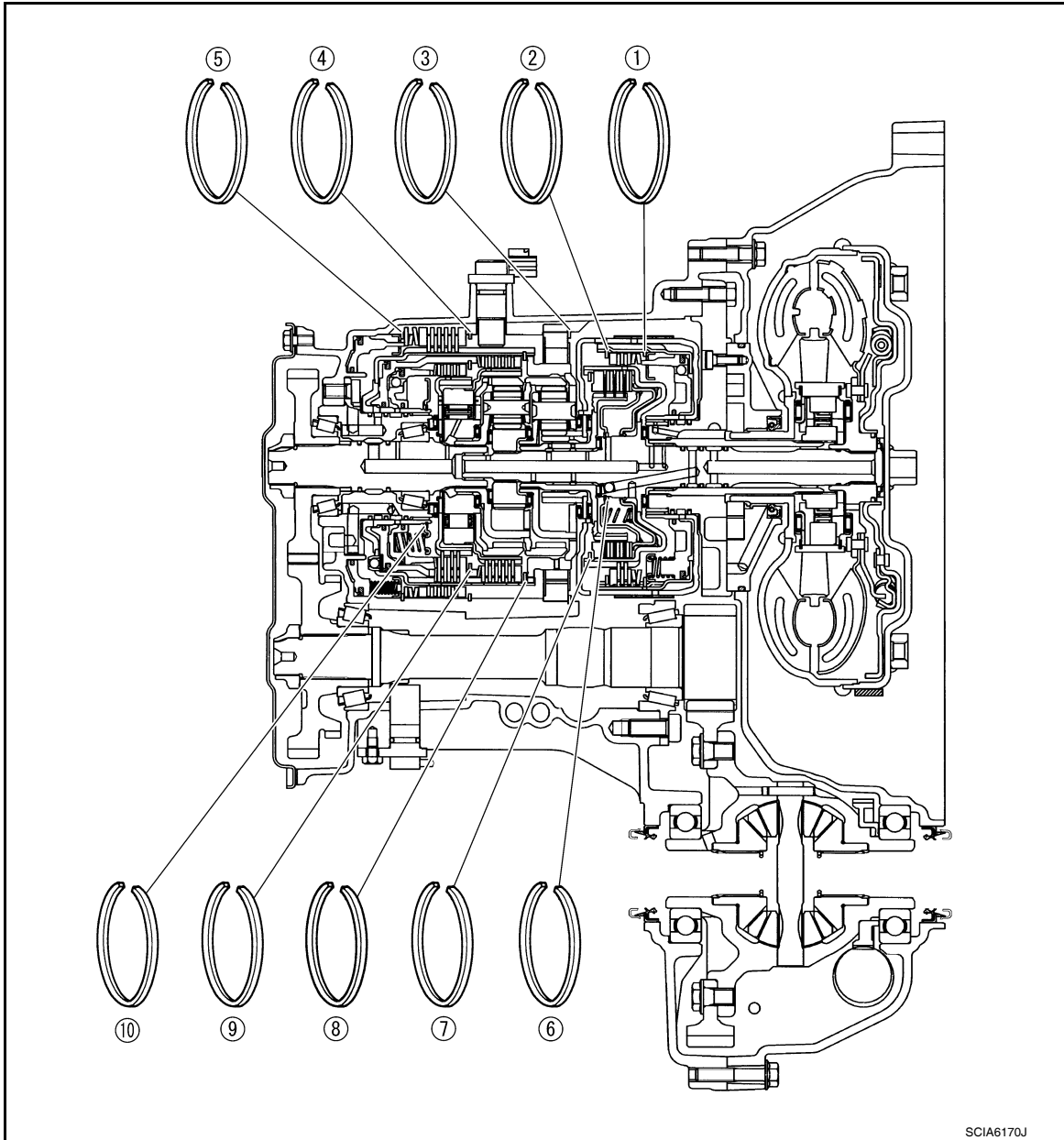

- Refer to [AT-374, "Adjusting shims, Needle Bearings, Thrust Washers and Snap Rings"](#).

A

B

AT

D

E

F

G

H

I

J

K

L

M

N

O

P

OVERHAUL

< SERVICE INFORMATION >

MR18DE ENGINE MODELS

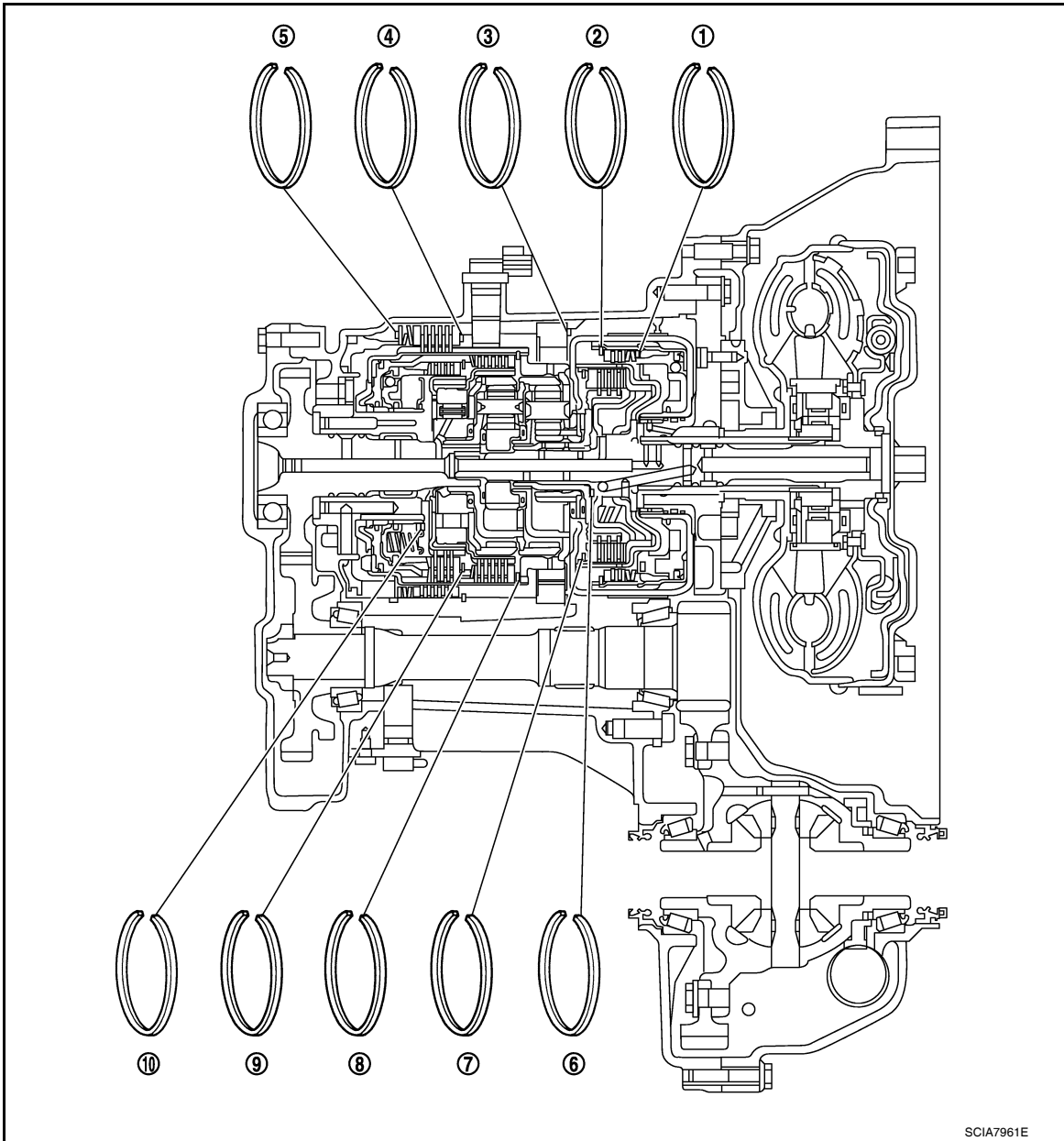

- Refer to [AT-374, "Adjusting shims, Needle Bearings, Thrust Washers and Snap Rings"](#).

DISASSEMBLY

< SERVICE INFORMATION >

DISASSEMBLY

Disassembly

INFOID:000000005928289

1. Drain ATF through drain hole.
2. Remove drain plug gasket from drain plug.

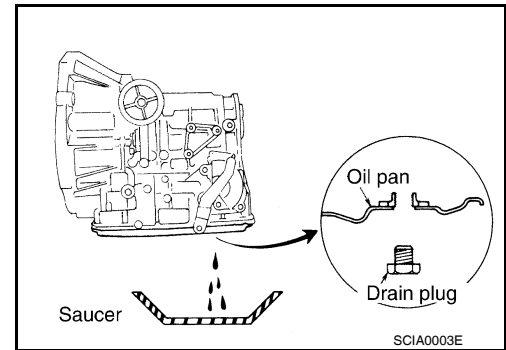

3. Remove torque converter.

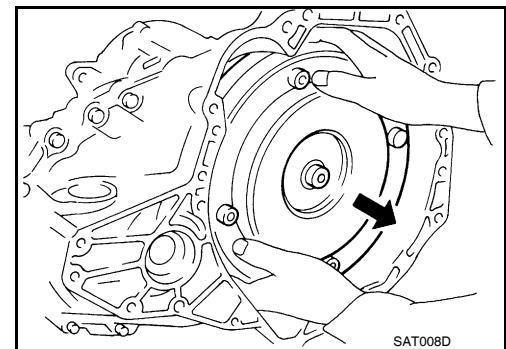

4. Check torque converter one-way clutch using check tool as shown.
 - a. Insert check tool into groove of bearing support built into one-way clutch outer race.
 - b. When fixing bearing support with check tool, rotate one-way clutch spline using screwdriver.
 - c. Check that inner race rotates clockwise only. If not, replace torque converter assembly.

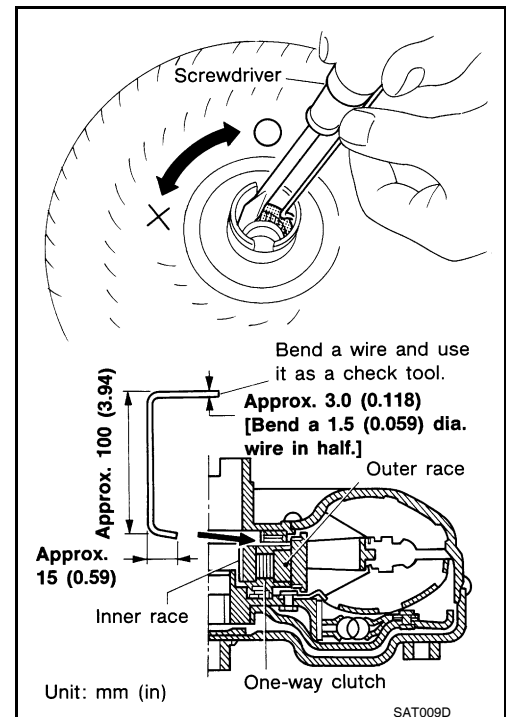

DISASSEMBLY

< SERVICE INFORMATION >

5. Remove input speed sensor (1) from transaxle case (2).
←: Bolt
6. Remove O-ring (3) from input speed sensor (1).

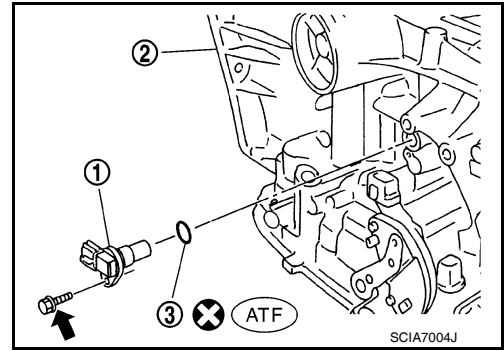

7. Remove output speed sensor (1) from transaxle case (2).
←: Bolt

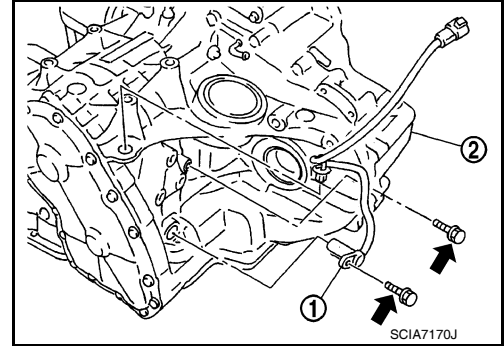

8. Remove plug or speedometer pinion according to the following procedures.
 - a. With ABS
 - i. Remove plug (1) from converter housing (2).
←: Bolt
 - ii. Remove O-ring (3) from plug (1).

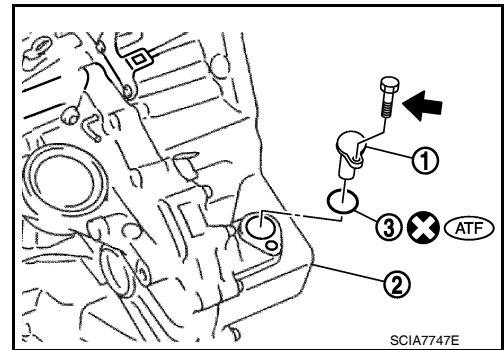

- b. Without ABS
 - i. Remove speedometer pinion (1) from converter housing (2).
←: Bolt
 - ii. Remove O-ring (3) from speedometer pinion (1).

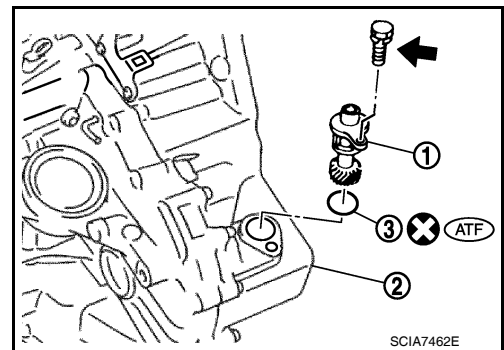

DISASSEMBLY

< SERVICE INFORMATION >

9. Set manual shaft (1) in "P" position.
10. Remove transmission range switch (2) from transaxle case.
←: Bolt
11. Remove oil pan bolts.
12. Remove oil pan and oil pan gasket.

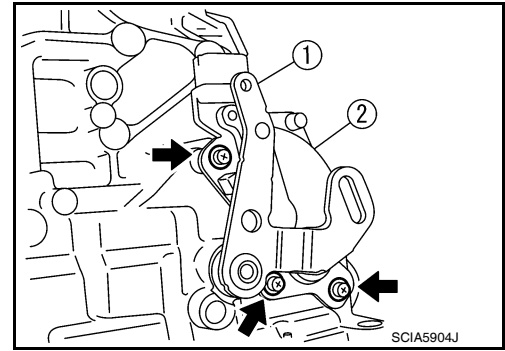

13. Check foreign materials in oil pan to help determine causes of malfunction. If the ATF is very dark, smells burned, or contains foreign particles, frictional material (clutches, band) may need replacement. A tacky film that will not wipe clean indicates varnish build up. Varnish can cause valves, servo, and clutches to stick and can inhibit pump pressure.
 - If frictional material is detected, replace radiator after repair of A/T. Refer to [CO-40](#).
14. Remove magnets from oil pan.

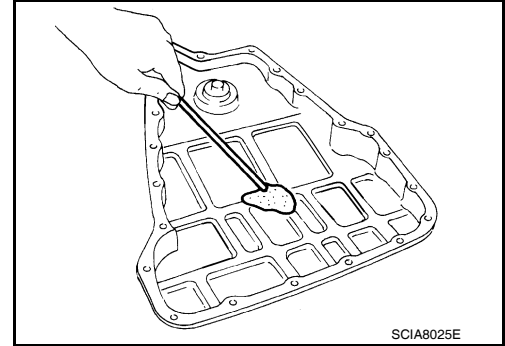

15. Remove control valve assembly according to the following procedures.
 - a. Remove snap ring (1) from terminal body (2).
CAUTION:
Do not expand snap ring (1) excessively.
 - b. Push terminal body (2) into transaxle case.

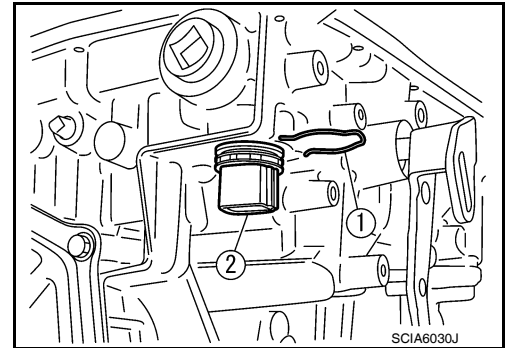

- c. Remove control valve assembly fitting bolts (A), (B) and (C).

Bolt length, number and location:

Bolt symbol	A	B	C
Bolt length "ℓ" [mm (in)]	40.0 mm (1.575 in)	33.0 mm (1.299 in)	43.5 mm (1.713 in)
			
Number of bolts	5	6	2

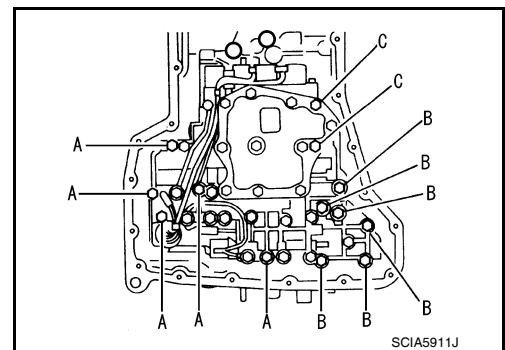

- d. Remove control valve assembly from transaxle case.
CAUTION:
Be careful not to drop manual valve.

DISASSEMBLY

< SERVICE INFORMATION >

16. Remove manual valve from control valve assembly.
- **Inspect the sliding surfaces of manual valve and valve body, and replace if damaged or dented.**

CAUTION:

Be careful not to drop manual valve.

17. Remove O-ring from terminal body.

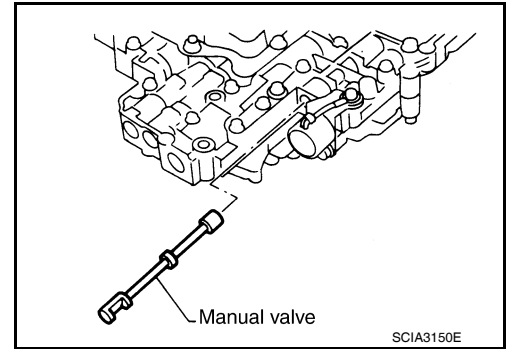

18. Remove return spring from servo release accumulator piston.

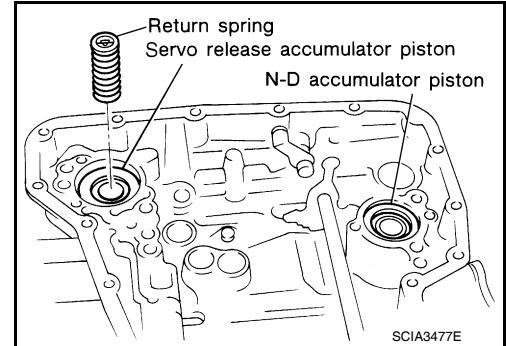

19. Apply compressed air into the oil hole as shown, and remove servo release accumulator piston from transaxle case.

CAUTION:

Strong flow of air will push the accumulator piston out along with a splash of ATF. Cover the area with lint-free cloth and blow air little by little to avoid this.

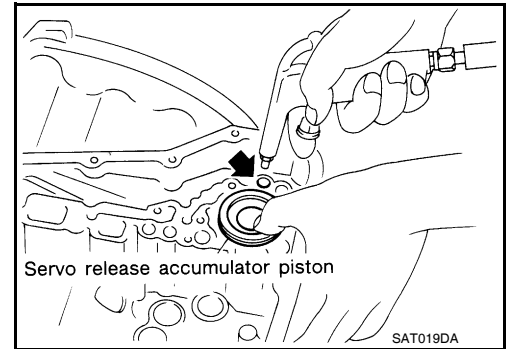

20. Apply compressed air into the oil hole as shown, and remove N-D accumulator piston and return spring from transaxle case.

CAUTION:

Strong flow of air will push the accumulator piston out along with a splash of ATF. Cover the area with lint free-cloth and blow air little by little to avoid this.

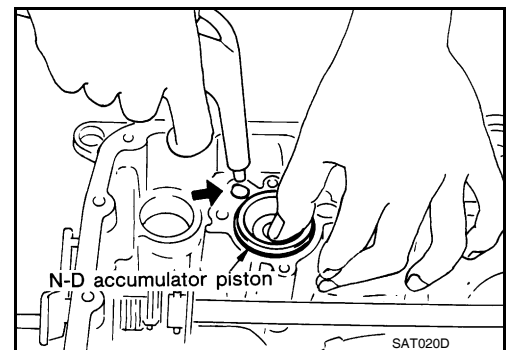

21. Remove O-rings (1) from servo release accumulator piston (2) and N-D accumulator piston (3).

CAUTION:

Wrap the removed servo release accumulator piston (2) and N-D accumulator piston (3) in a lint-free cloth.

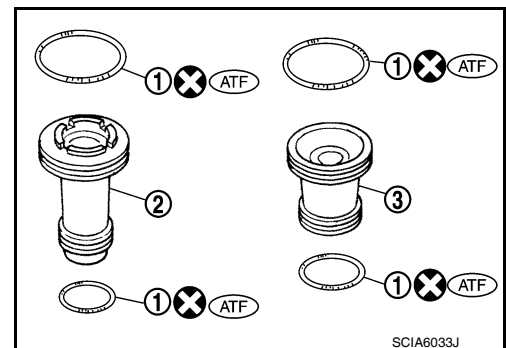

DISASSEMBLY

< SERVICE INFORMATION >

- Inspect the sliding surfaces of each accumulator piston and transaxle case, and replace if damaged or dented.

(1): Servo release accumulator piston
(2): N-D accumulator piston

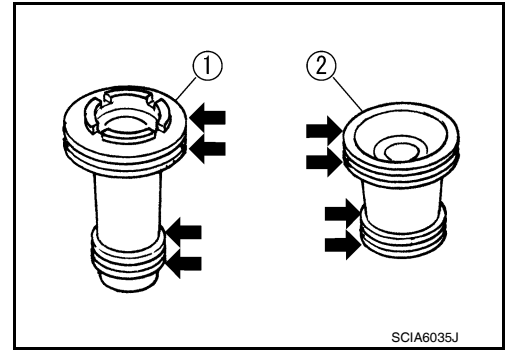

- Inspect each return spring, and replace if deformed or worn. Refer to [AT-376. "Accumulator" for free length \(L1\) and length \(L2\).](#)

(1): Return spring (Servo release accumulator)
(2): Return spring (N-D accumulator)

CAUTION:

Do not remove spring retainer (3).

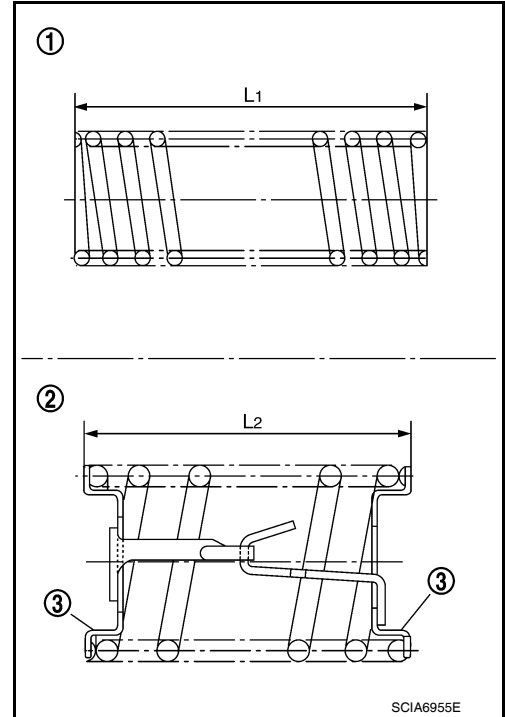

22. Remove lip seals (1) from transaxle case.

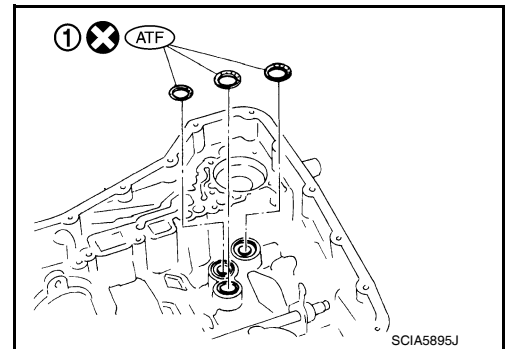

23. Remove converter housing according to the following procedures.

- a. Remove converter housing bolts (1) and (2) using a power tool.

A
B
AT
D
E
F
G
H
I
J
K
L
M
N
O
P

DISASSEMBLY

< SERVICE INFORMATION >

- HR16DE engine models

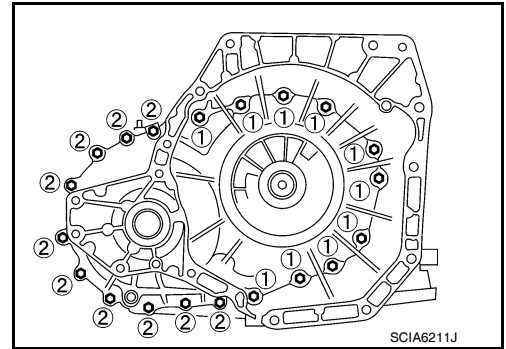

- MR18DE engine models

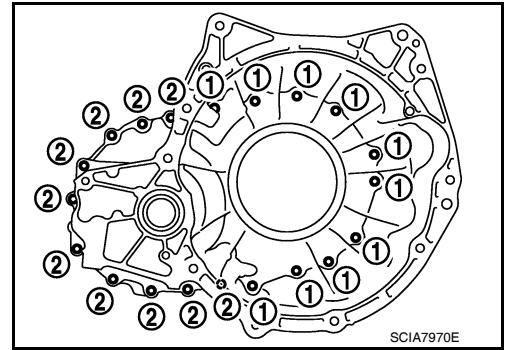

- Remove bracket from converter housing
- Remove converter housing by tapping it lightly.
- Remove O-ring from differential lubricant hole.

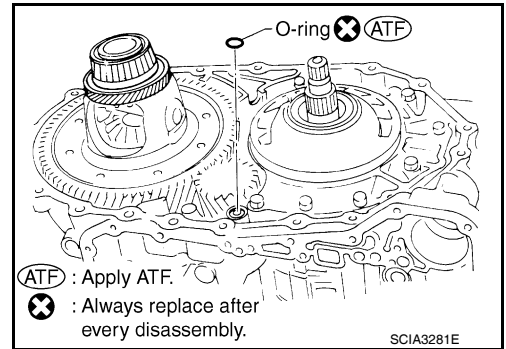

24. Remove final drive assembly from transaxle case.

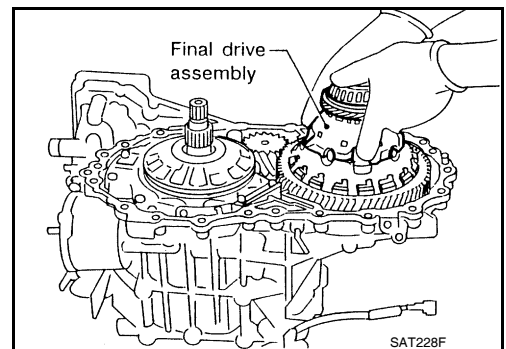

DISASSEMBLY

< SERVICE INFORMATION >

25. Remove differential side bearing outer race from transaxle case and converter housing. (MR18DE engine models)

Tool number : KV381054S0 (J-34286)

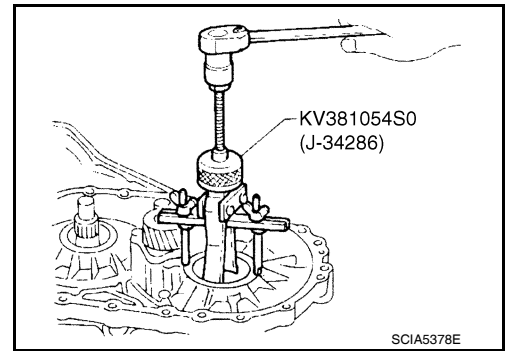

26. Remove differential side bearing adjusting shim from transaxle case.

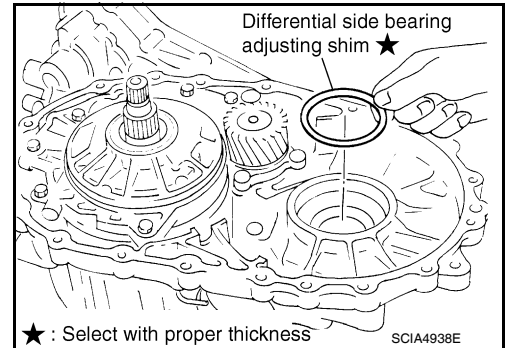

27. Remove RH differential side oil seal from converter housing using a suitable tool.

CAUTION:

Be careful not to scratch converter housing.

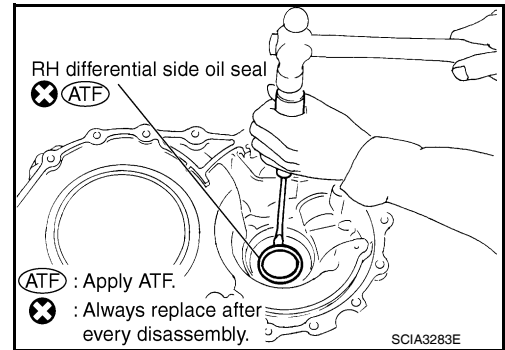

28. Remove differential lubricant tube (1) and clips (2) from converter housing.

← Bolt

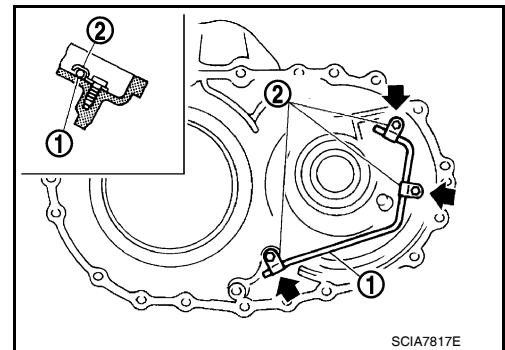

29. Remove oil pump assembly according to the following procedures.

A
B
AT
D
E
F
G
H
I
J
K
L
M
N
O
P

DISASSEMBLY

< SERVICE INFORMATION >

a. Remove O-ring from input shaft assembly (high clutch drum).

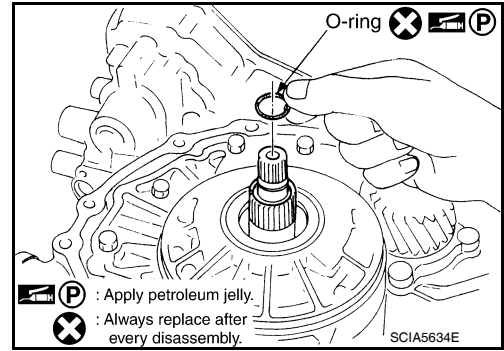

b. Remove oil pump assembly bolts, and then remove oil pump assembly (1) from transaxle case.

c. Remove O-ring from oil pump assembly (1).

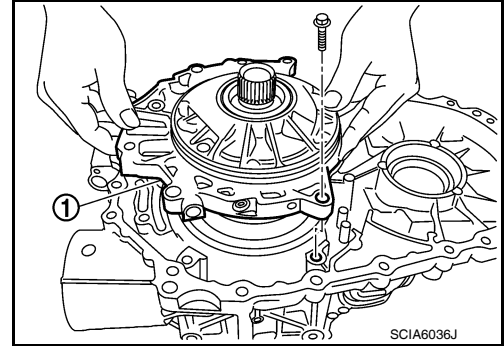

d. Remove bearing race (1) and thrust washer (2) from oil pump assembly (3).

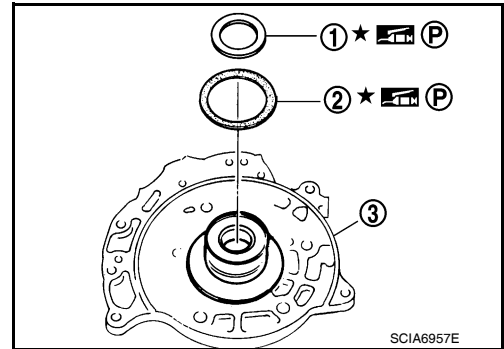

30. Remove brake band according to the following procedures.

a. Loosen lock nut (1), and then remove anchor end pin (2) and lock nut (1) as a set from transaxle case.

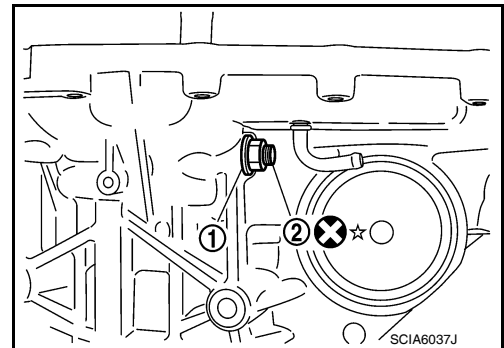

DISASSEMBLY

< SERVICE INFORMATION >

b. Remove brake band from transaxle case.

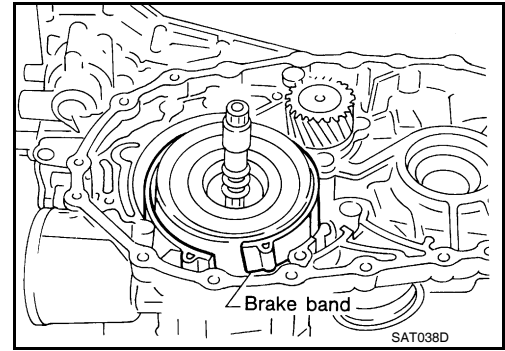

- To prevent brake linings from cracking or peeling, do not stretch the flexible band unnecessarily. When removing brake band, always secure it with a clip as shown in the figure. Leave the clip in position after removing brake band.

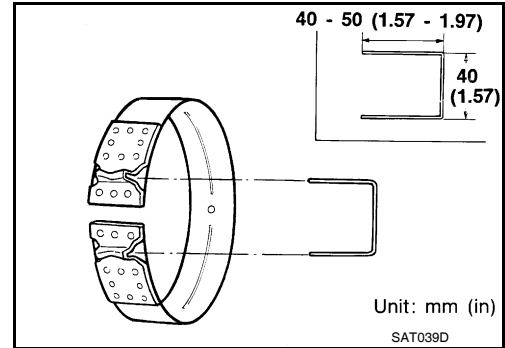

c. Check brake band facing for damage, cracks, wear or burns.

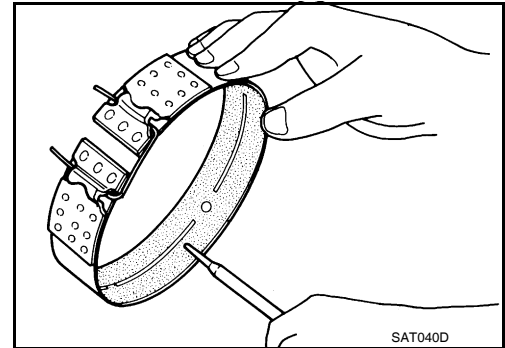

31. Remove input shaft assembly (high clutch assembly) and reverse clutch assembly according to the following procedures.

a. Remove input shaft assembly (high clutch assembly) (1) with reverse clutch assembly (2).

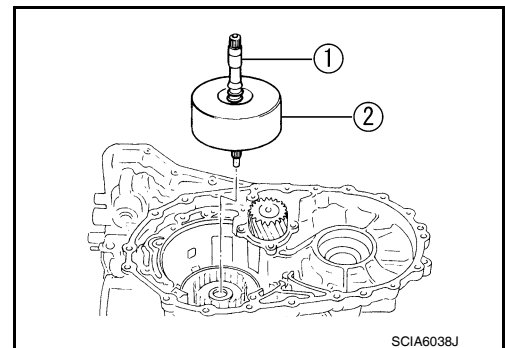

A
B
AT
D
E
F
G
H
I
J
K
L
M
N
O
P

DISASSEMBLY

< SERVICE INFORMATION >

- b. Remove input shaft assembly (high clutch assembly) (1) from reverse clutch assembly (2).

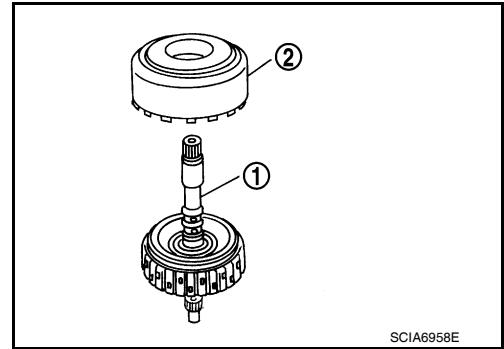

- c. Remove needle bearing (1) from input shaft assembly (high clutch drum) (2).
- **Inspect needle bearing (1) and input shaft assembly (high clutch drum) (2), and replace if damaged or worn.**

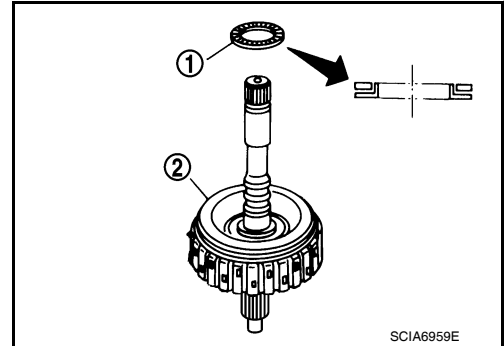

32. Remove needle bearing from high clutch hub.
- **Inspect needle bearing, and replace if damaged or worn.**

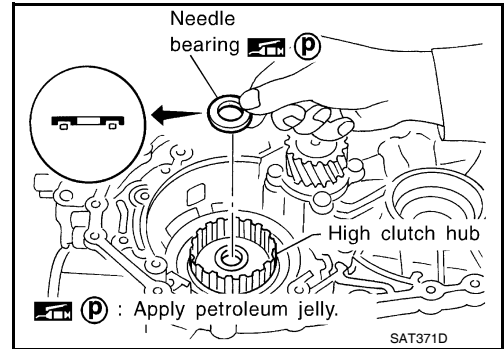

33. Remove high clutch hub from front sun gear.
- **Inspect high clutch hub, and replace if damaged or worn.**

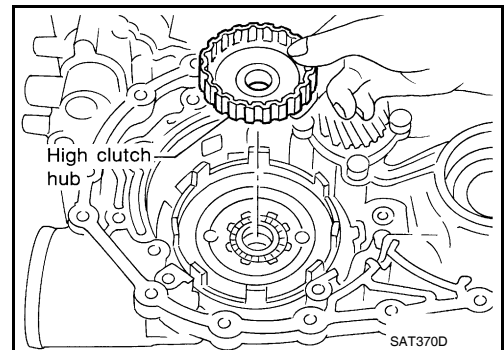

34. Remove needle bearing from front sun gear.
- **Inspect needle bearing, and replace if damaged or worn.**

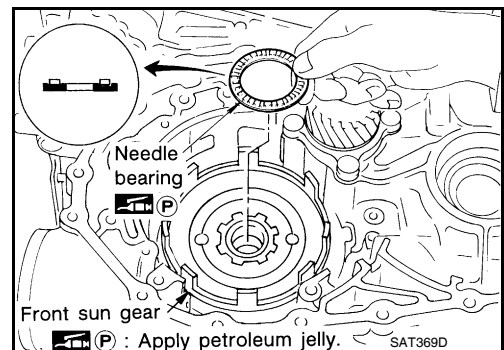

DISASSEMBLY

< SERVICE INFORMATION >

35. Remove front sun gear from front planetary carrier.

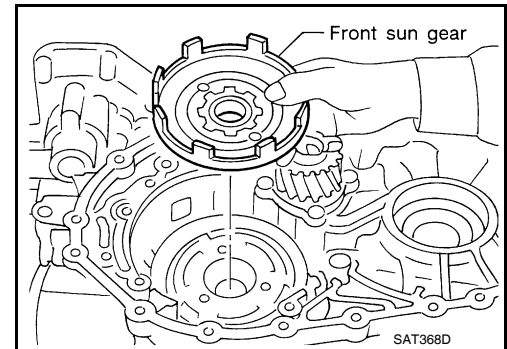

36. Remove needle bearing (1) from front sun gear (2).
• **Inspect needle bearing (1) and front sun gear (2), and replace if damaged or worn.**

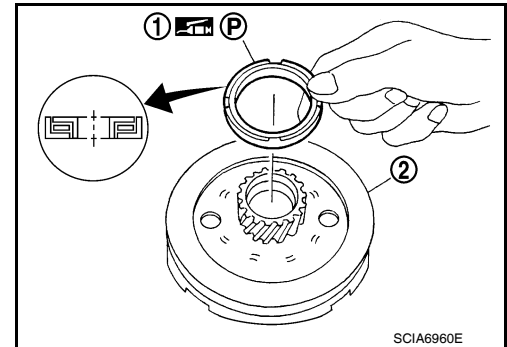

37. Remove front planetary carrier and low one-way clutch according to the following procedures.

a. Remove snap ring using a flat-bladed screwdriver.

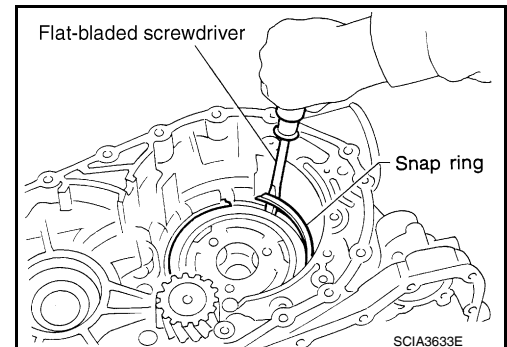

b. Remove low one-way clutch (1) and front planetary carrier (2) as a set from transaxle case.

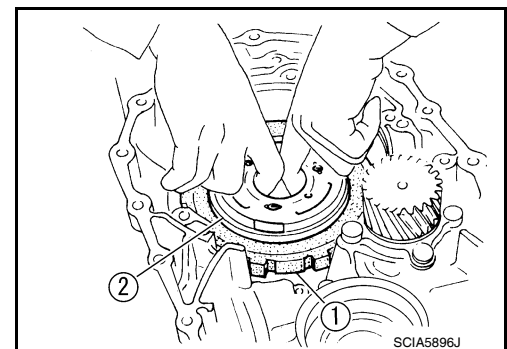

A
B
AT
D
E
F
G
H
I
J
K
L
M
N
O
P

DISASSEMBLY

< SERVICE INFORMATION >

- c. Check that low one-way clutch rotates counter-clockwise around front planetary carrier. Then try to turn it clockwise and check that it is locked.

- **Replace low one-way clutch if necessary.**

- d. Remove low one-way clutch from front planetary carrier by turning it in the direction of unlock.

- **Inspect low one-way clutch, and replace if damaged or worn.**

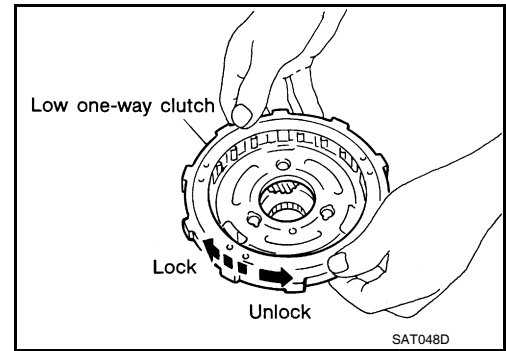

- e. Remove needle bearing (1) from front planetary carrier (2).

- **Inspect needle bearing (1) and front planetary carrier (2), and replace if damaged or worn.**

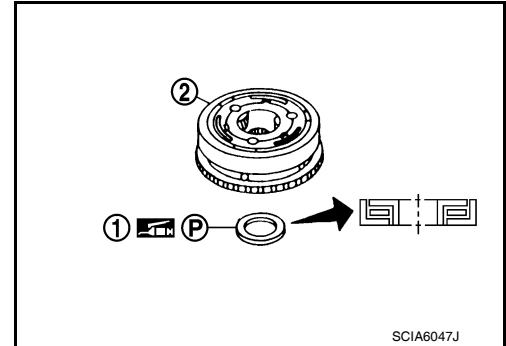

- f. Check clearance between pinion washer and front planetary carrier using feeler gauge.

Standard clearance and allowable limit:

Refer to [AT-378, "Planetary Carrier"](#).

- **Replace front planetary carrier if the clearance exceeds allowable limit.**

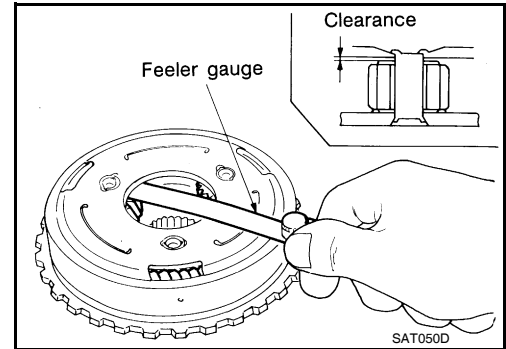

38. Remove rear planetary carrier and rear sun gear according to the following procedures.

- a. Remove rear planetary carrier (with rear sun gear) from transaxle case.

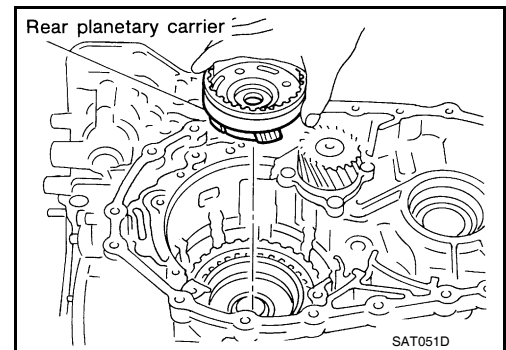

DISASSEMBLY

< SERVICE INFORMATION >

- b. Remove rear sun gear from rear planetary carrier.
• **Inspect rear sun gear, and replace if damaged or worn.**

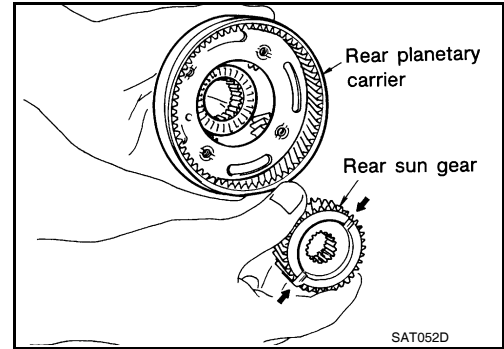

- c. Remove needle bearing (1) from rear planetary carrier (2).
• **Inspect needle bearing (1) and rear planetary carrier (2), and replace if damaged or worn.**

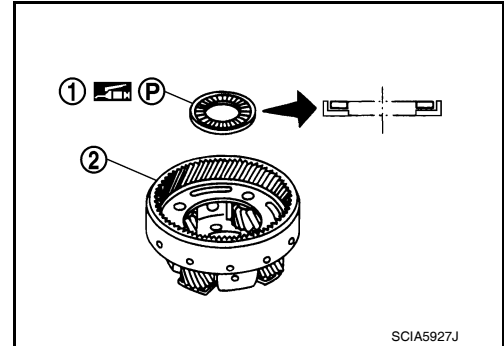

- d. Check clearance between pinion washer and rear planetary carrier using feeler gauge.

Standard clearance and allowable limit:

Refer to [AT-378, "Planetary Carrier"](#).

- **Replace rear planetary carrier if the clearance exceeds allowable limit.**

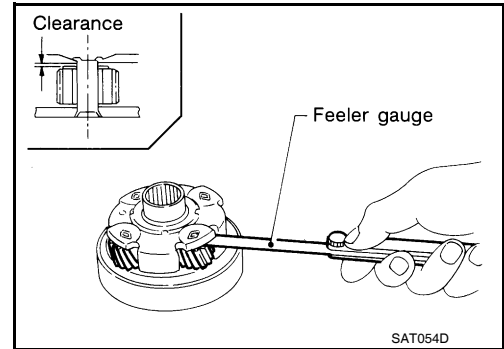

39. Remove rear internal gear (1) and forward clutch hub (2) as a set from forward clutch drum.

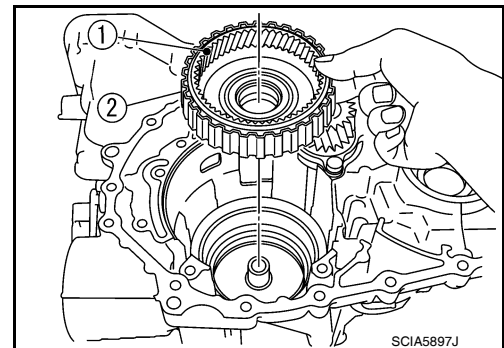

40. Remove needle bearing (1) from rear internal gear (2).
• **Inspect needle bearing (1), and replace if damaged or worn.**

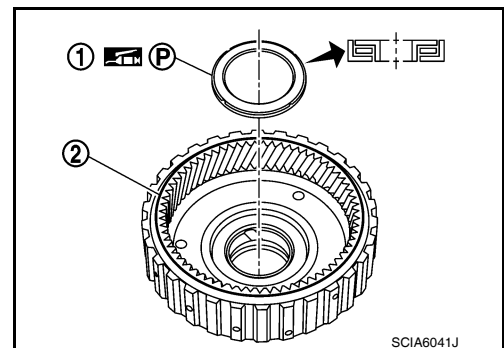

A
B
AT
D
E
F
G
H
I
J
K
L
M
N
O
P

DISASSEMBLY

< SERVICE INFORMATION >

41. Remove overrun clutch hub (1) from forward clutch drum.

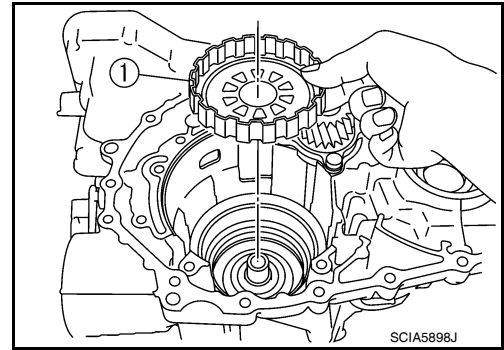

42. Remove thrust washer (1) from overrun clutch hub (2).
• **Inspect thrust washer (1) and overrun clutch hub (2), and replace if damaged or worn.**

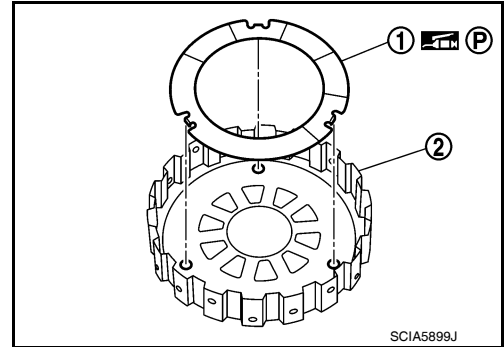

43. Remove forward clutch assembly and overrun clutch assembly (1) from transaxle case.

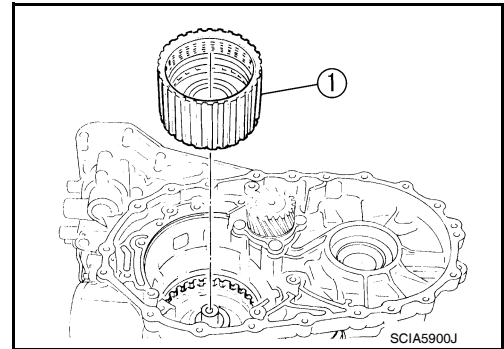

44. Remove needle bearing (1) and thrust washer (2) from bearing retainer.
• **Inspect needle bearing (1) and thrust washer (2), and replace if damaged or worn.**

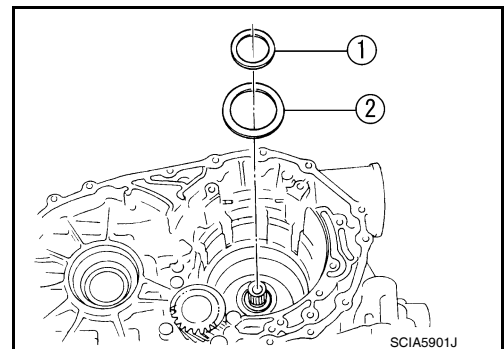

45. Remove output shaft assembly according to the following procedures.
a. HR16DE engine models.

DISASSEMBLY

< SERVICE INFORMATION >

- i. Remove side cover bolts (1), then remove side cover by lightly tapping it with a soft hammer.
CAUTION:
Be careful not to damage cover.
- ii. Remove side cover gasket from side cover.
- iii. Set manual shaft in "P" position to lock idler gear and output gear.
- iv. Unlock both idler gear and output gear lock nuts with a suitable tool.

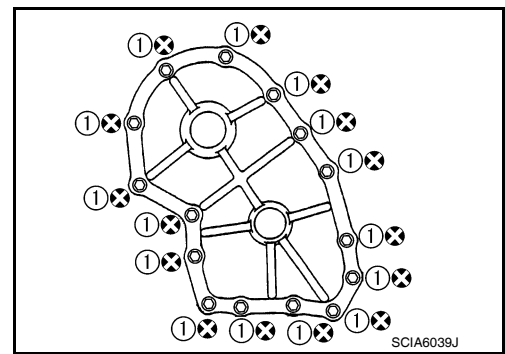

- v. Remove idler gear and output gear lock nuts.

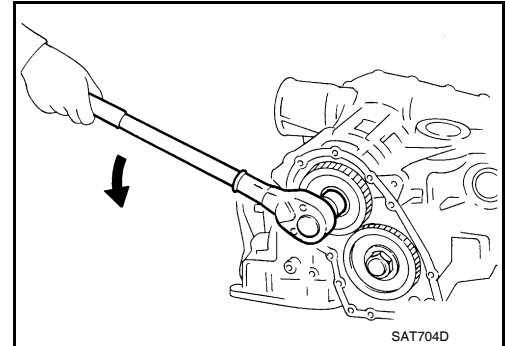

- vi. Remove out put gear (1) and idler gear (2) using Tool (A).

Tool number : ST27180001 (J-25726-A)

- vii. Removing reduction pinion gear and output shaft from transaxle case.

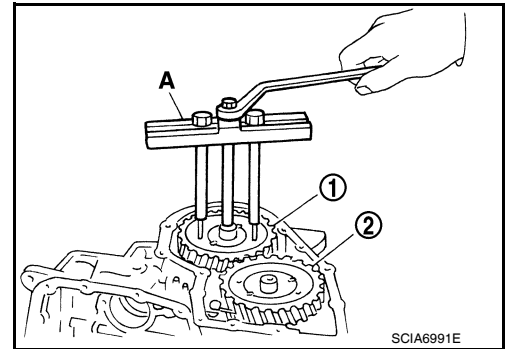

- viii. Remove reduction pinion gear adjusting shim (1) from reduction pinion gear (2).
- ix. Remove output gear adjusting spacer (3) from output shaft (4).

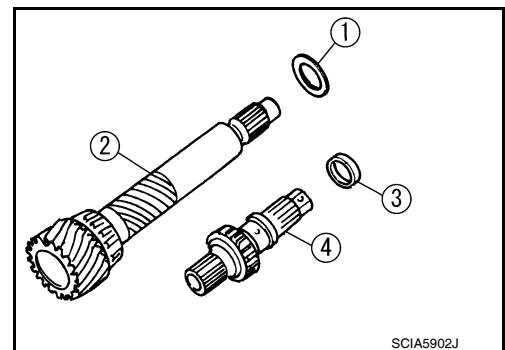

- b. MR18DE engine models.

DISASSEMBLY

< SERVICE INFORMATION >

- i. Remove side cover bolts (A) and (B).

CAUTION:

- Do not mix bolts (A) and (B).
- Always replace bolts (A) as they are self-sealing bolts.

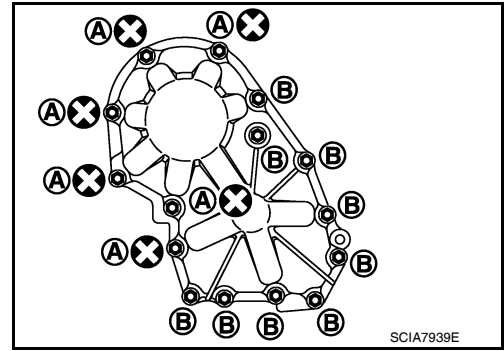

- ii. Remove side cover by lightly tapping it using a soft hammer.

CAUTION:

- Be careful not to drop output shaft assembly. It might come out when removing side cover.
- Be careful not to damage side cover.

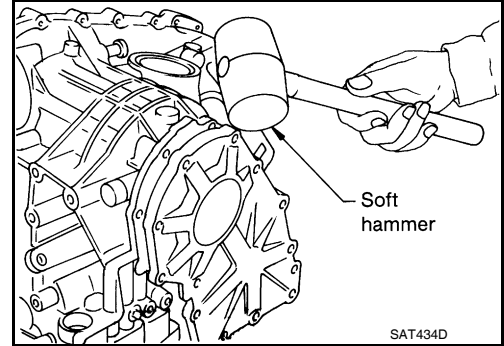

- iii. Remove output shaft adjusting shim.

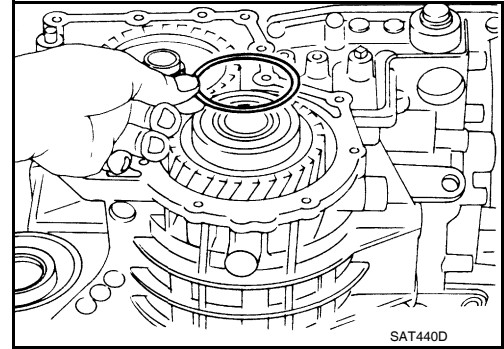

- iv. Remove output shaft assembly.

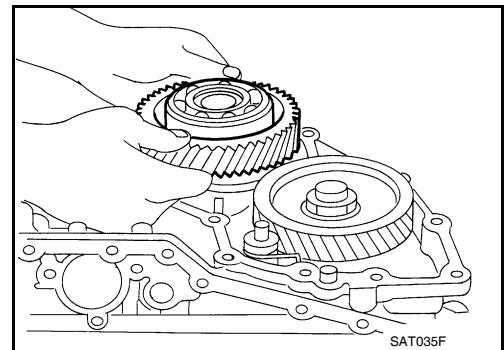

- If output shaft assembly came off with side cover, tap side cover with a soft hammer to separate.

CAUTION:

- Be careful not to damage side cover.

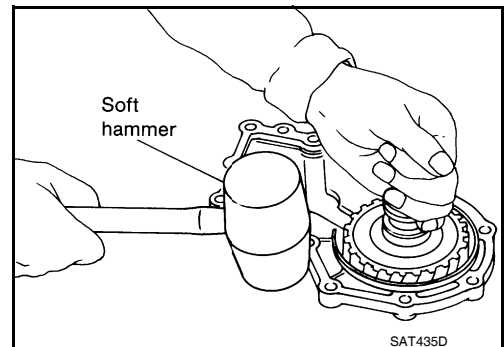

DISASSEMBLY

< SERVICE INFORMATION >

- v. Remove needle bearing.
- **Check needle bearing, and replace if damaged or worn.**

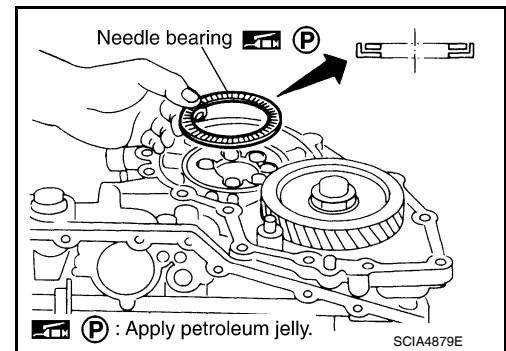

- vi. Set manual shaft to "P" position to lock idler gear.
vii. Unlock idler gear lock nut with pin punch.

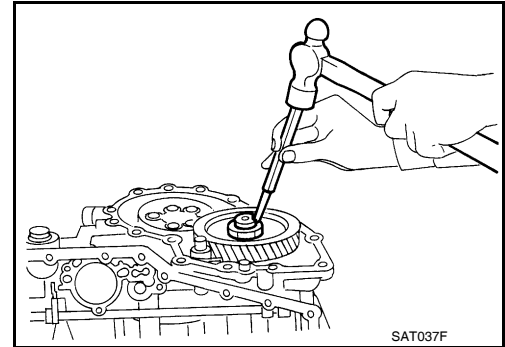

- viii. Remove idler gear lock nut.

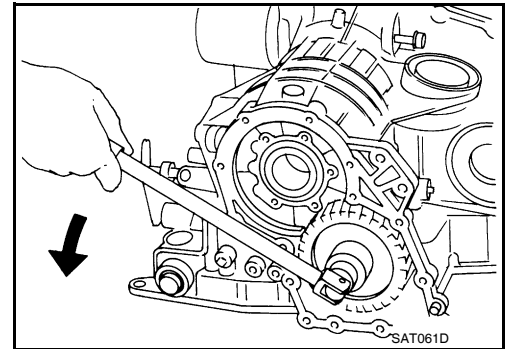

- ix. Remove idler gear using Tool.

Tool number : ST27180001 (J-25726-A)

- x. Remove reduction pinion gear.

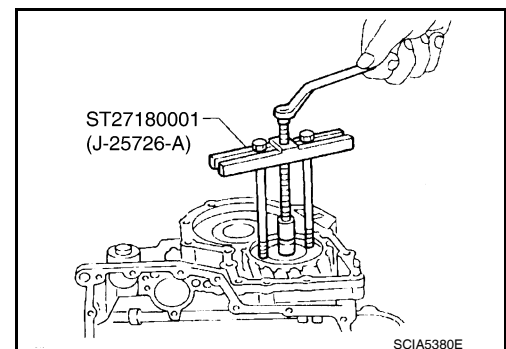

- xi. Remove reduction pinion gear adjusting shim from reduction pinion gear.

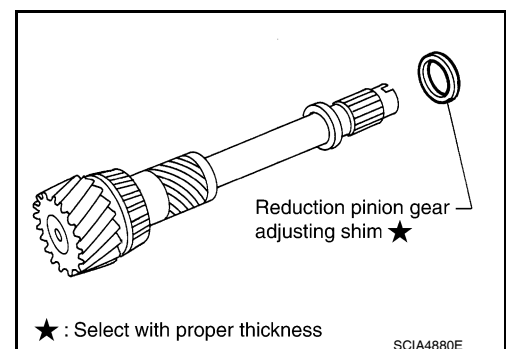

A
B
AT
D
E
F
G
H
I
J
K
L
M
N
O
P

DISASSEMBLY

< SERVICE INFORMATION >

46. Remove bearing retainer bolts, and then remove bearing retainer (1) from transaxle case.

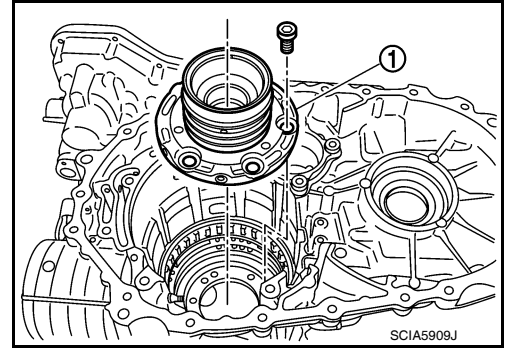

47. Remove return spring (2) from parking shaft (3) using a suitable tool.

(1): Parking pawl

- **Inspect return spring (2), and replace if damaged or worn.**

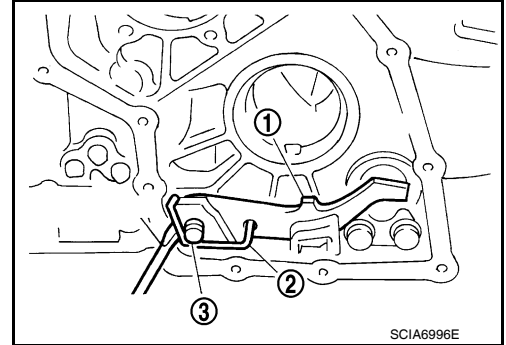

48. Draw out parking shaft (1), and then remove parking pawl (2) from transaxle case.

- **Inspect parking shaft (1) and parking pawl (2), and replace if damaged or worn.**

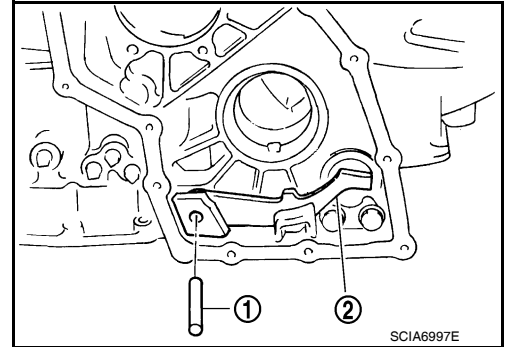

49. Remove parking actuator support (1) from transaxle case.

- **Inspect parking actuator support (1), and replace if damaged or worn.**

50. Remove snap ring from transaxle case using a suitable tool.

51. Remove governor cap from transaxle case.

52. Remove O-ring from governor cap.

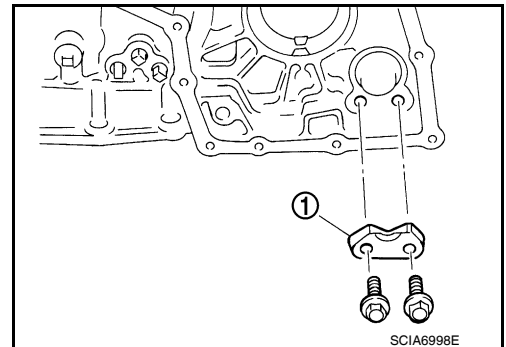

53. Remove LH differential side oil seal from transaxle case using a suitable tool.

CAUTION:

Be careful not to scratch transaxle case.

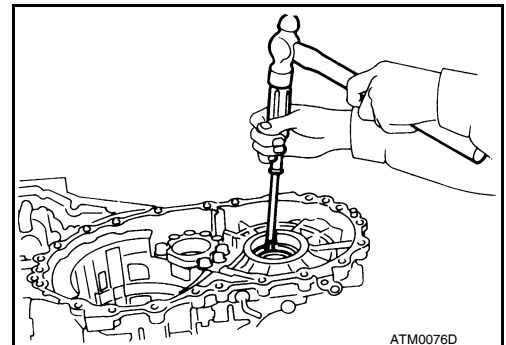

REPAIR FOR COMPONENT PARTS

< SERVICE INFORMATION >

REPAIR FOR COMPONENT PARTS

Manual Shaft

INFOID:000000005928290

COMPONENTS

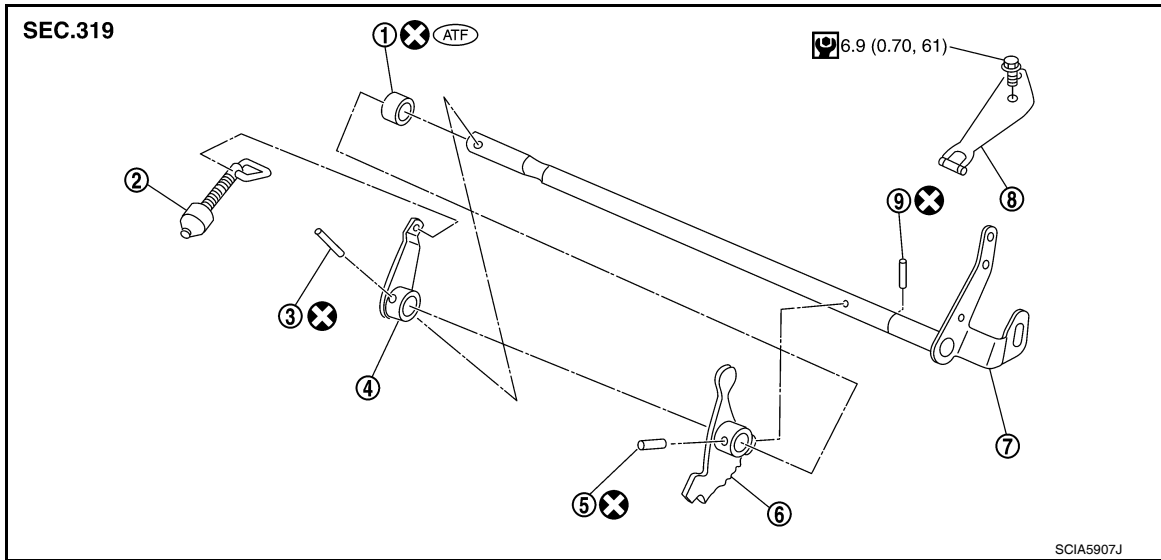

- | | | |
|--------------------------|------------------|------------------|
| 1. Manual shaft oil seal | 2. Parking rod | 3. Retaining pin |
| 4. Parking rod plate | 5. Retaining pin | 6. Manual plate |
| 7. Manual shaft | 8. Detent spring | 9. Retaining pin |

REMOVAL

1. Remove detent spring from transaxle case.

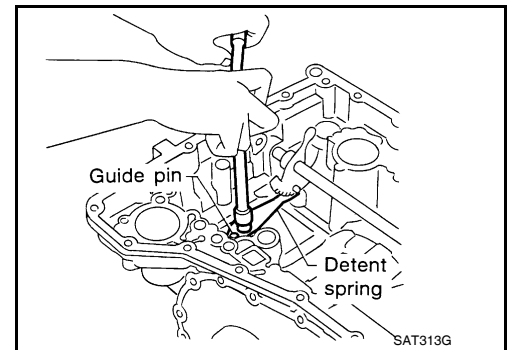

2. Drive out retaining pin of manual plate using Tool.

Tool number : ST23540000 (J-25689-A)

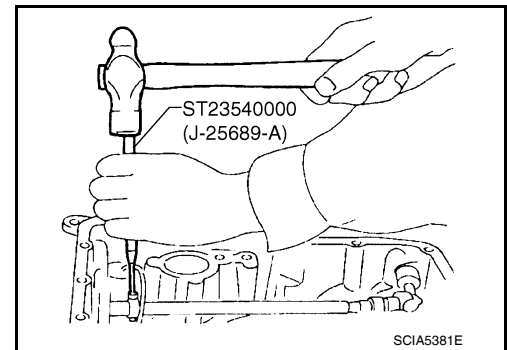

A
B
AT
D
E
F
G
H
I
J
K
L
M
N
O
P

REPAIR FOR COMPONENT PARTS

< SERVICE INFORMATION >

3. Pull out retaining pin (2) of parking rod plate (1) using suitable tool.

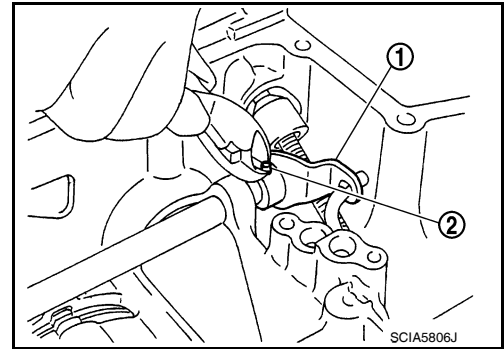

4. Pull out retaining pin (1) of manual shaft using suitable tool.

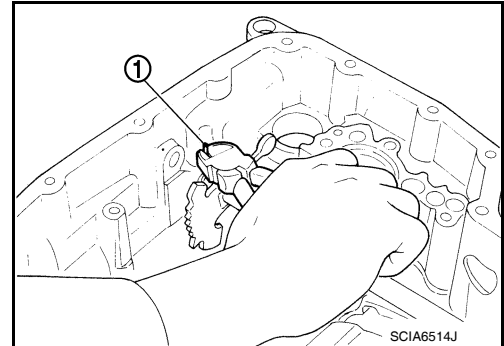

5. Remove parking rod plate (with parking rod) (3) from manual shaft (1).
6. Remove parking rod from parking rod plate (3).
7. Remove manual plate (2) from manual shaft (1).
8. Draw out manual shaft (1) from transaxle case.

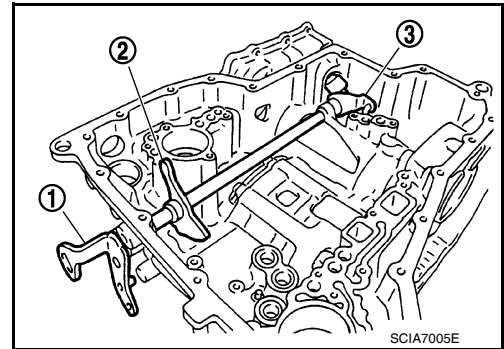

9. Remove manual shaft oil seal from transaxle case using a suitable tool.

CAUTION:

Be careful not to scratch transaxle case.

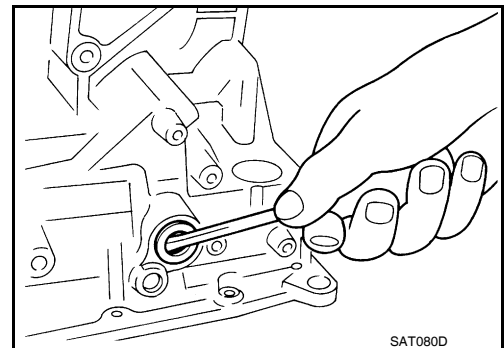

INSPECTION

Check component parts, and replace if damaged or worn.

INSTALLATION

REPAIR FOR COMPONENT PARTS

< SERVICE INFORMATION >

1. Drive manual shaft oil seal into transaxle case using a drift [commercial service tool: 22 mm (0.87 in) dia.].
CAUTION:
 - Do not reuse manual shaft oil seal.
 - Apply ATF to outer surface of manual shaft oil seal.
2. Install parking rod to parking rod plate.

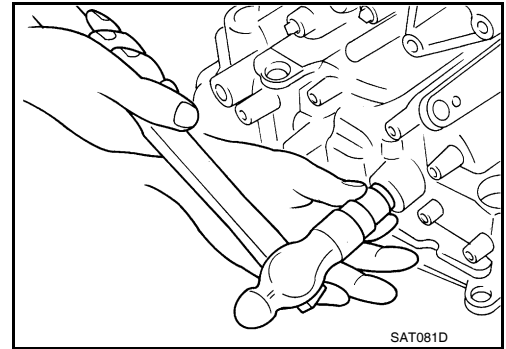

3. Insert manual shaft (1) to transaxle case, and install manual plate (2) to manual shaft (1).
4. Install parking rod plate (with parking rod) (3) to manual shaft (1).

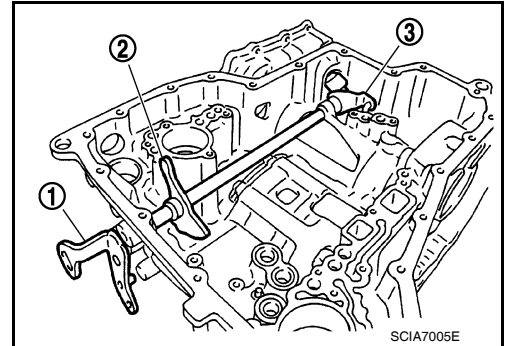

5. Align groove of manual shaft and hole of transaxle case using a pin punch (A) [commercial service tool: 2 mm (0.08 in) dia.].
6. Drive retaining pin of manual shaft into transaxle case using Tool (B).

Tool number: ST23540000 (J-25689-A)

CAUTION:
Do not reuse retaining pin.

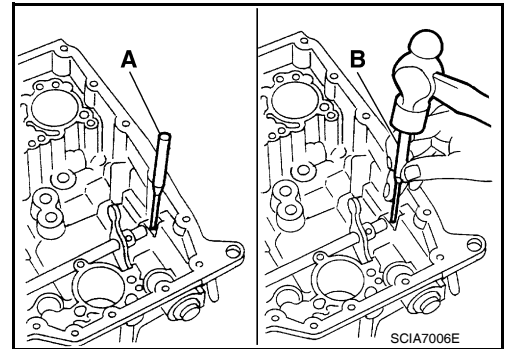

7. Set parking rod plate (1) onto manual shaft, and drive retaining pin (2) of parking rod plate (1) using tool (A).

Tool number: ST23540000 (J-25689-A)

CAUTION:
The retaining pin end should protrude approx. 3mm (0.12 in) (B) from the outer surface of parking rod plate (1).

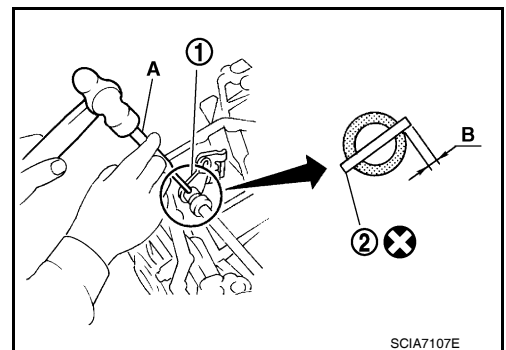

8. Set manual plate (1) onto manual shaft, and drive retaining pin (2) of manual plate (1) using tool (A).

Tool number: ST23540000 (J-25698-A)

CAUTION:
The retaining pin end should protrude approx. 3mm (0.12 in) (B) from the outer surface of manual plate (1).

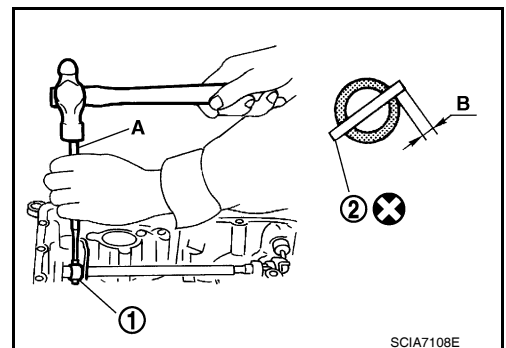

REPAIR FOR COMPONENT PARTS

< SERVICE INFORMATION >

9. Install detent spring on transaxle case.
10. Tighten detent spring bolt to the specified torque. Refer to [AT-275. "Manual Shaft"](#).

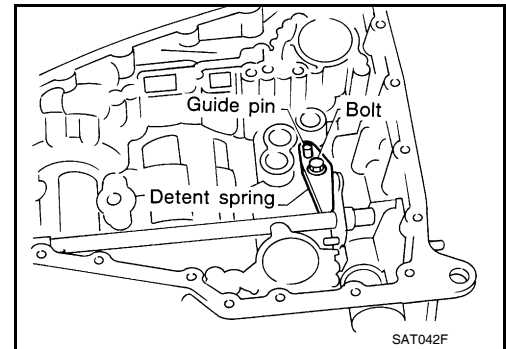

Oil Pump

INFOID:000000005928291

COMPONENTS

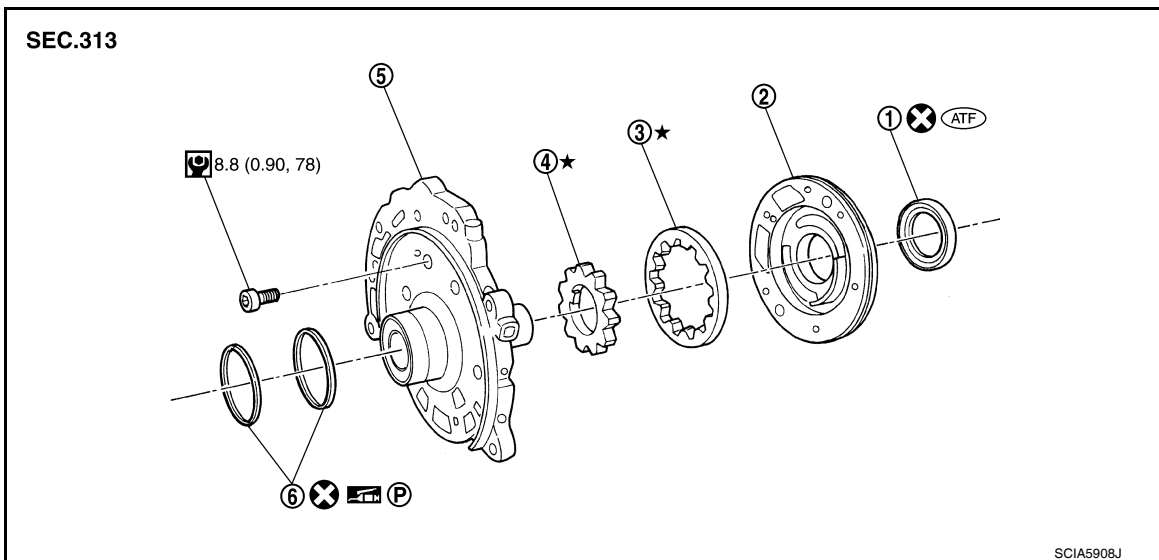

- | | | |
|------------------------------|---------------------|---------------|
| 1. Oil pump housing oil seal | 2. Oil pump housing | 3. Outer gear |
| 4. Inner gear | 5. Oil pump cover | 6. Seal ring |

DISASSEMBLY

1. Remove seal rings (1) from oil pump assembly (2).

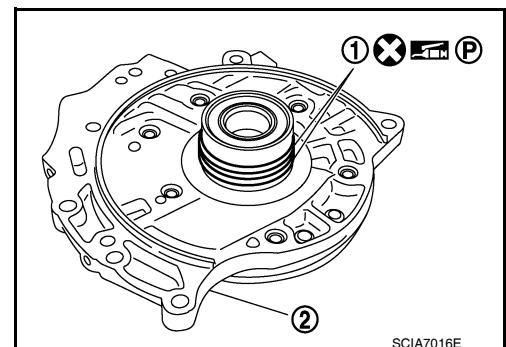

REPAIR FOR COMPONENT PARTS

< SERVICE INFORMATION >

2. Remove bolts in the order as shown, and remove oil pump cover.

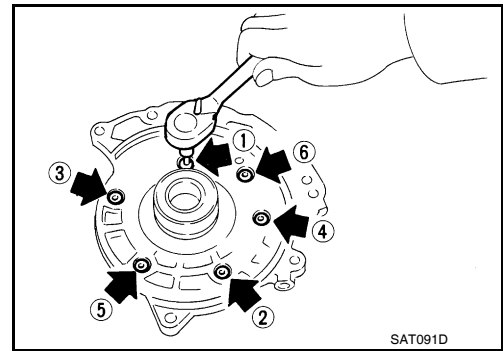

3. Remove inner gear and outer gear from oil pump housing.

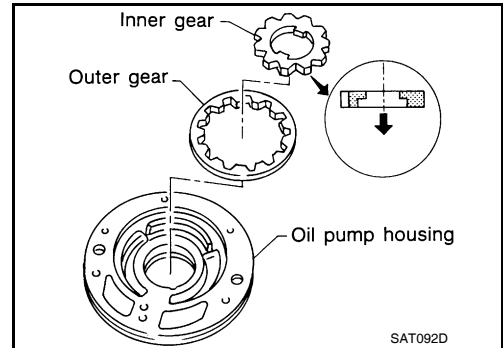

4. Remove oil pump housing oil seal using a flat-bladed screwdriver.

CAUTION:

Be careful not to scratch oil pump housing.

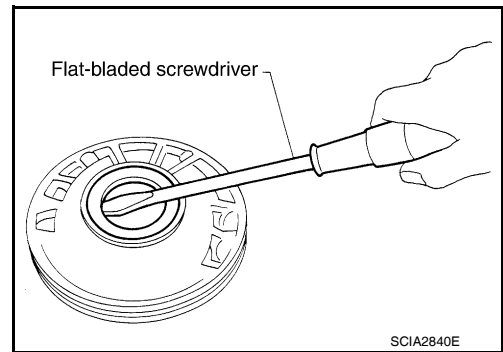

INSPECTION

Oil Pump Housing, Oil Pump Cover, Inner Gear and Outer Gear
Check for wear or damage. Replace if necessary.

Side Clearances

A
B
AT
D
E
F
G
H
I
J
K
L
M
N
O
P

REPAIR FOR COMPONENT PARTS

< SERVICE INFORMATION >

- Measure side clearance of inner gear and outer gear in at least four places around each outside edge. Clearances measured values should be within the specified clearance.

Standard clearance: Refer to [AT-378, "Oil Pump"](#).

- If clearance is less than standard, select inner gear and outer gear as a set so that clearance is within specifications. Refer to "Parts Information" for the inner gear and outer gear selection.
- If clearance is more than standard, replace whole oil pump assembly except oil pump cover.

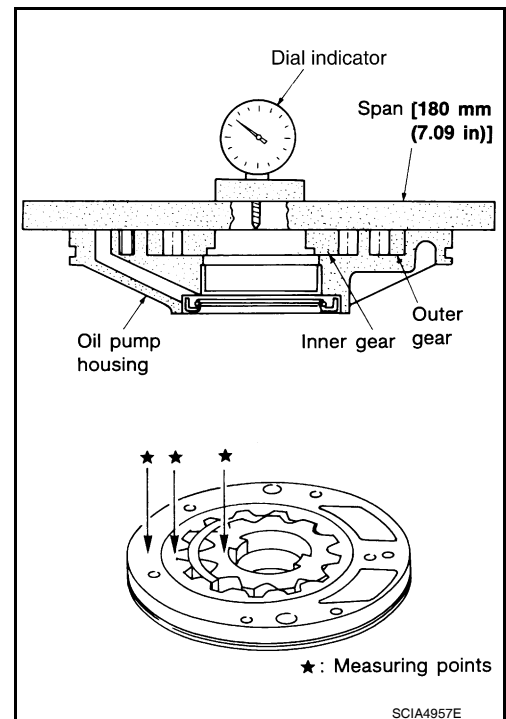

- Measure clearance between outer gear and oil pump housing.

Standard clearance and allowable limit:

Refer to [AT-378, "Oil Pump"](#).

- If not within allowable limit, replace whole oil pump assembly except oil pump cover.

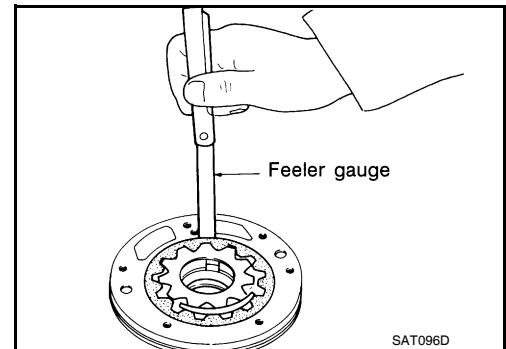

Seal Ring Clearance

- Measure clearance between seal ring and ring groove.

Standard clearance and allowable limit:

Refer to [AT-378, "Oil Pump"](#).

- If not within allowable limit, replace oil pump cover assembly.

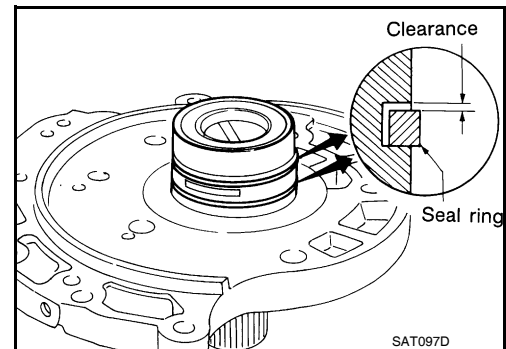

ASSEMBLY

REPAIR FOR COMPONENT PARTS

< SERVICE INFORMATION >

1. Install oil pump housing oil seal on oil pump housing.

Tool number : ST33400001 (J-26082)

CAUTION:

- Do not reuse oil pump housing oil seal.
- Apply ATF to outer surface of oil pump housing oil seal.

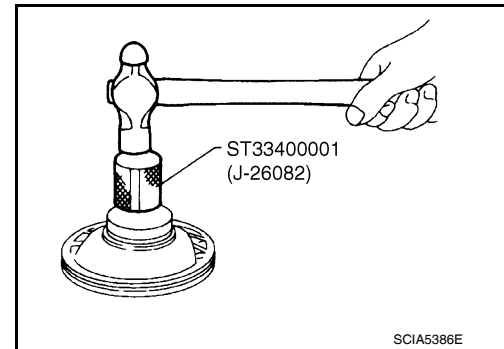

2. Install inner gear and outer gear on oil pump housing.

CAUTION:

Be careful with the direction of inner gear.

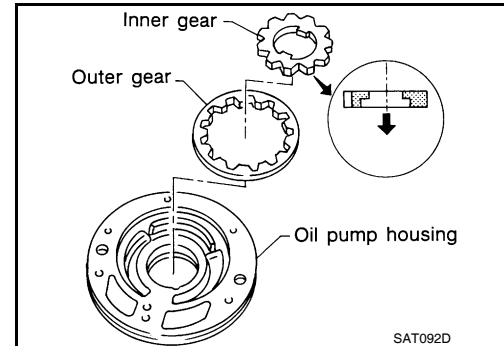

3. Install oil pump cover on oil pump housing.

- a. Wrap masking tape around splines of oil pump cover assembly to protect seal. Position oil pump cover assembly on oil pump housing assembly, then remove masking tape.
- b. Tighten oil pump cover bolts in the order as shown, and then tighten them to the specified torque in the same order. Refer to [AT-278, "Oil Pump"](#).

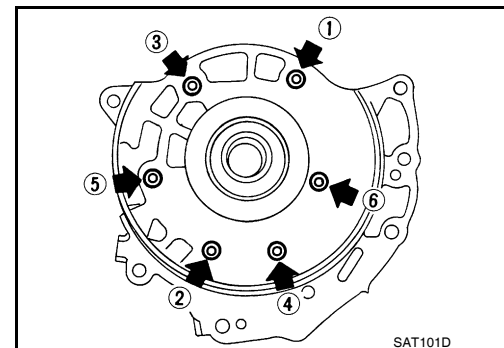

4. Install seal rings (1) to oil pump assembly (2) carefully after packing ring groove with petroleum jelly.

CAUTION:

Do not spread gap of seal rings (1) excessively while installing. The seal rings (1) may be deformed.

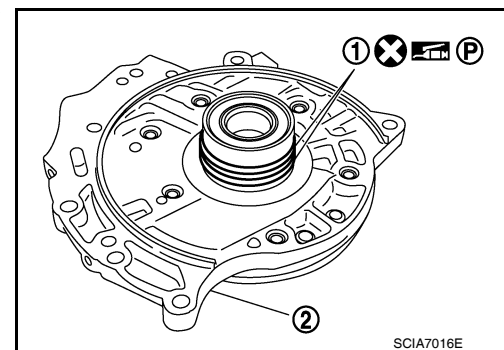

Control Valve Assembly

COMPONENTS

INFOID:000000005928292

REPAIR FOR COMPONENT PARTS

< SERVICE INFORMATION >

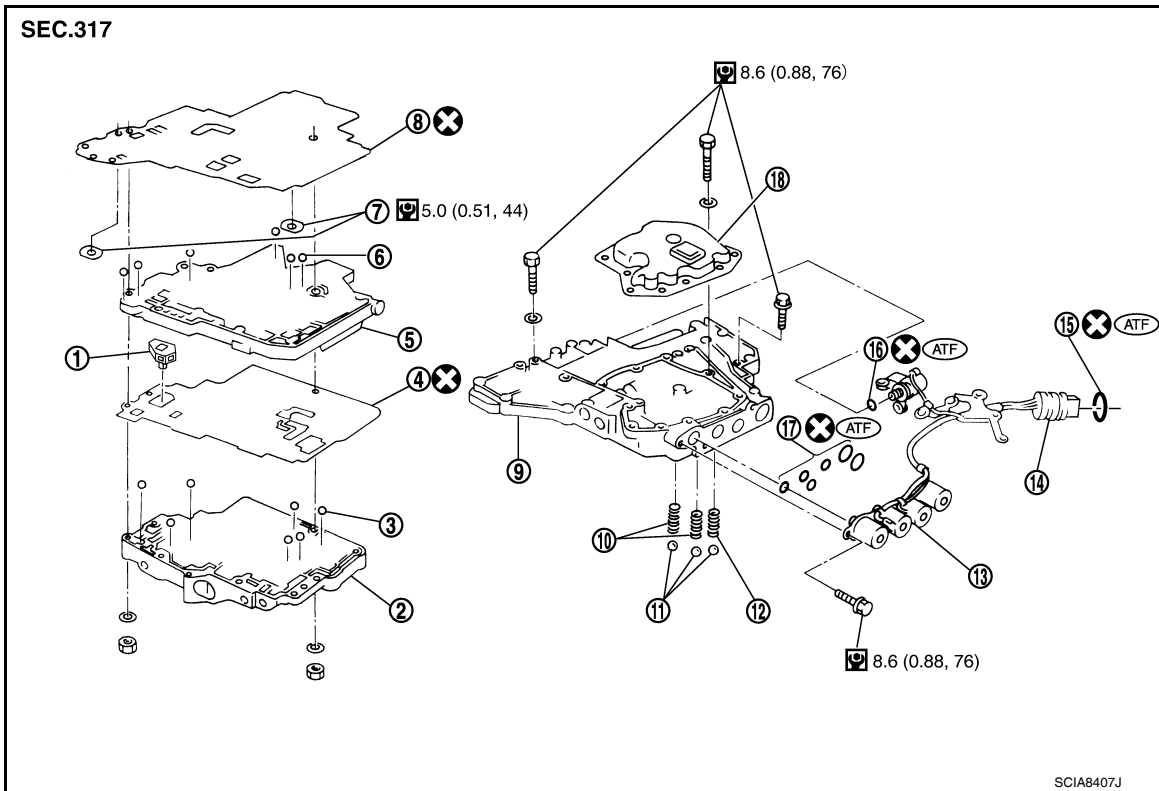

- | | | |
|---------------------------------------|-----------------------------|--|
| 1. Pilot filter | 2. Control valve upper body | 3. Steel ball |
| 4. Separating plate | 5. Control valve inter body | 6. Steel ball |
| 7. Support plate | 8. Separating plate | 9. Control valve lower body |
| 10. Line pressure relief valve spring | 11. Check ball | 12. Torque converter pressure holding spring |
| 13. Solenoid valve assembly | 14. Terminal body | 15. O-ring |
| 16. O-ring | 17. O-ring | 18. Oil strainer |

DISASSEMBLY

Place control valve assembly with control valve upper body (1) side down. Remove bolts (A) to (G), reamer bolts (F), nuts and support plates (4) according to the following procedures. Separate control valve upper body (1), control valve inter body (2) and control valve lower body (3).

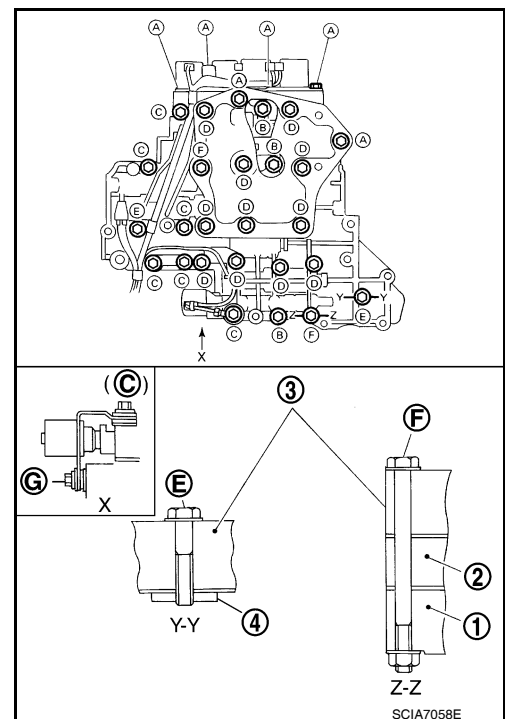

REPAIR FOR COMPONENT PARTS

< SERVICE INFORMATION >

Bolt length, number and location:

Bolt symbol	A	B	C	D	E	F*	G
Bolt length "ℓ" [mm (in)] 	13.5 (0.531)	58.0 (2.283)	40.0 (1.575)	66.0 (2.598)	33.0 (1.299)	78.0 (3.071)	18.0 (0.709)
Number of bolts	6	3	6	11	2	2	1

*: Reamer bolt and nut.

1. Remove bolts (A), (D), reamer bolt (F) and nut, and remove oil strainer (1) from control valve assembly.

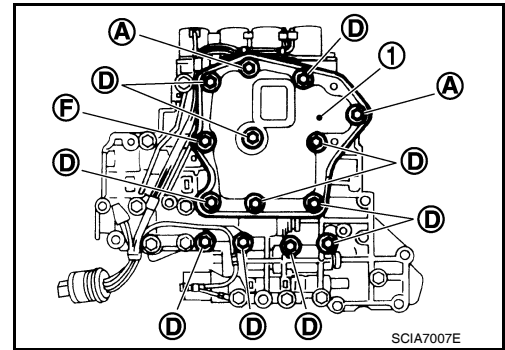

2. Remove bolts (A), (C) and (G), and then remove solenoid valve assembly (1) from control valve assembly.

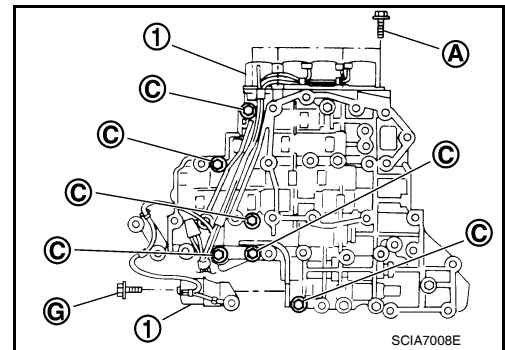

3. Remove O-rings from solenoid valves and terminal body.

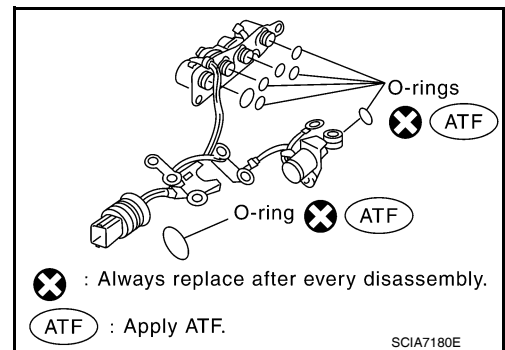

4. Place control valve upper body face down, and remove bolts (B), reamer bolt (F) and nut.

CAUTION:

Remove bolts with control valve upper body facing down, because control valve upper body and control valve inter body may come off and steel ball may fall and be lost.

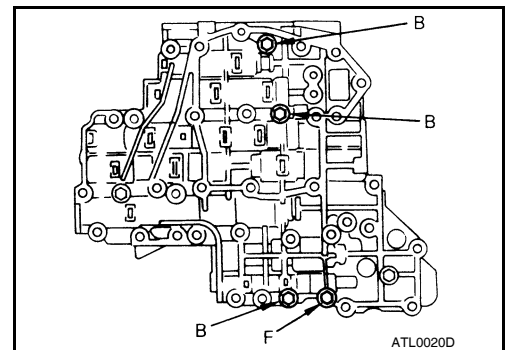

REPAIR FOR COMPONENT PARTS

< SERVICE INFORMATION >

5. Remove control valve lower body (1) from control valve inter body (2).
(3): Control valve upper body

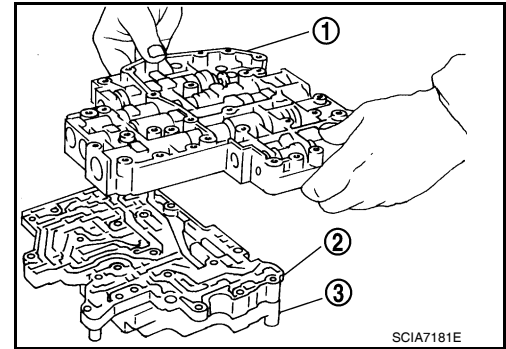

6. Turn over control valve lower body (1).
7. Remove bolts (E), support plates (2) and separating plate (3) from control valve lower body (1).

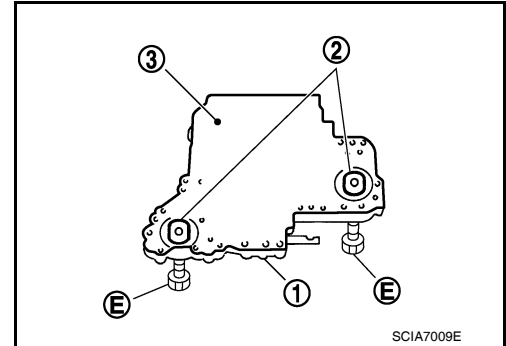

8. Remove check balls (1), line pressure relief valve springs (2) and torque converter pressure holding spring (3) from control valve lower body (4).

CAUTION:

Be careful not to lose check balls (1), line pressure relief valve springs (2) and torque converter pressure holding spring (3).

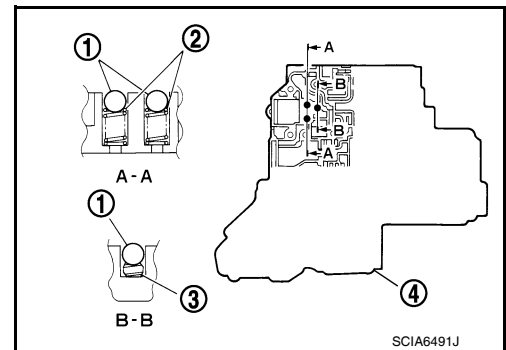

9. Remove control valve inter body from control valve upper body.

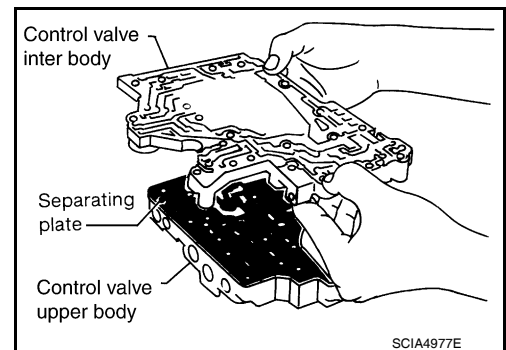

10. Remove pilot filter (1) from control valve upper body (2).
11. Remove separating plate from control valve upper body (2).

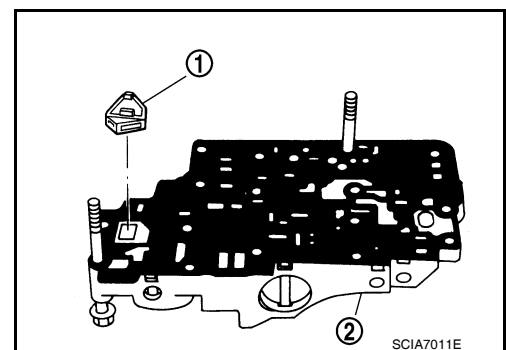

REPAIR FOR COMPONENT PARTS

< SERVICE INFORMATION >

12. Check to see that steel balls are properly positioned in control valve inter body and then remove them.

CAUTION:

Be careful not to lose steel balls.

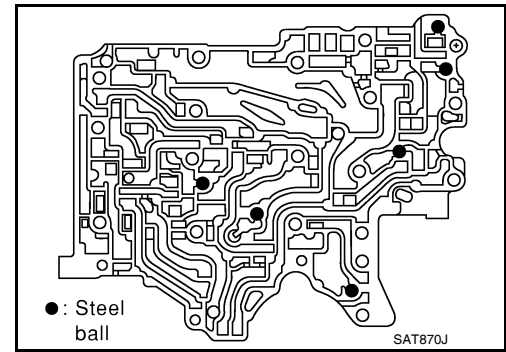

13. Check to see that steel balls are properly positioned in control valve upper body and then remove them.

CAUTION:

Be careful not to lose steel balls.

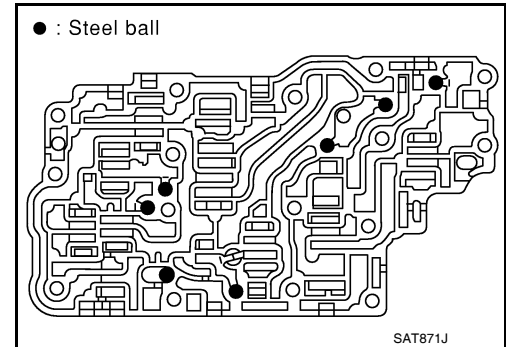

INSPECTION

Control Valve Lower and Upper Bodies

CAUTION:

Be careful not to lose these parts.

- Check to see that retainer plates are properly positioned in control valve lower body.

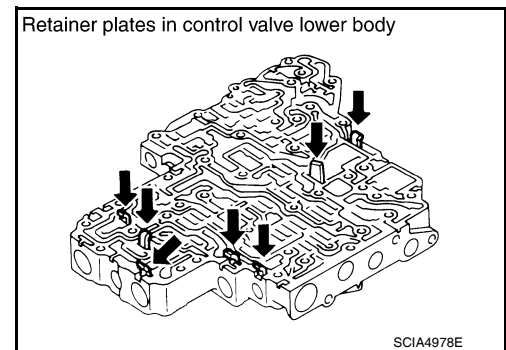

- Check to see that retainer plates are properly positioned in control valve upper body.

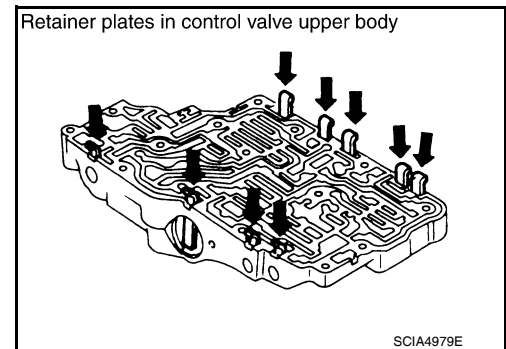

Oil Strainer

A
B
AT
D
E
F
G
H
I
J
K
L
M
N
O
P

REPAIR FOR COMPONENT PARTS

< SERVICE INFORMATION >

Check wire netting of oil strainer for damage. Replace if necessary.

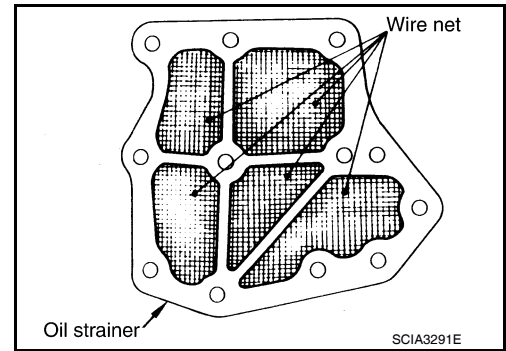

Shift Solenoid Valves "A and B", Line Pressure Solenoid Valve, Torque Converter Clutch Solenoid Valve and Overrun Clutch Solenoid Valve

Measure resistance.

- For shift solenoid valve A, refer to [AT-141, "Component Inspection"](#).
- For shift solenoid valve B, refer to [AT-146, "Component Inspection"](#).
- For line pressure solenoid valve, refer to [AT-137, "Component Inspection"](#).
- For torque converter clutch solenoid valve, refer to [AT-126, "Component Inspection"](#).
- For overrun clutch solenoid valve, refer to [AT-151, "Component Inspection"](#).

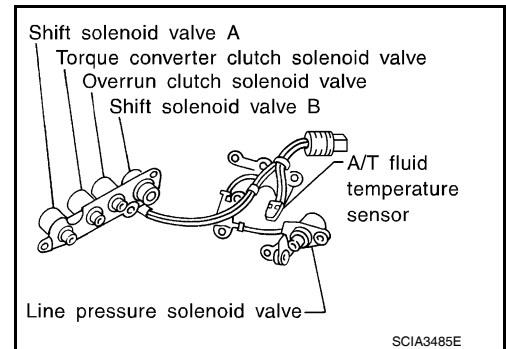

A/T Fluid Temperature Sensor

Measure resistance.

- For A/T fluid temperature sensor, refer to [AT-160, "Component Inspection"](#).

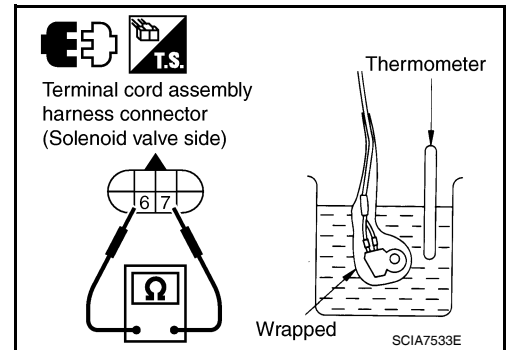

Line Pressure Relief Valve Springs and Torque Converter Pressure Holding Spring

- Check each spring for damage or deformation. Also measure free length and outer diameter. Refer to [AT-375, "Control Valves"](#).
- Replace springs if deformed or fatigued.

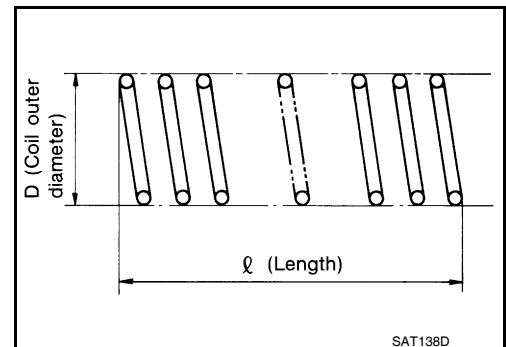

ASSEMBLY

REPAIR FOR COMPONENT PARTS

< SERVICE INFORMATION >

1. Install control valve upper, inter and lower body.
- a. Place oil circuit of control valve upper body face up. Install steel balls in their proper positions.

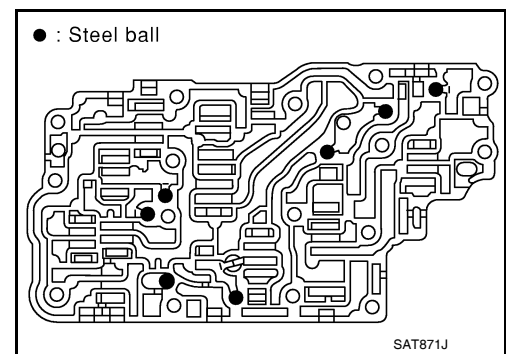

- b. Install reamer bolts (F) from bottom of control valve upper body (1). Using reamer bolts (F) as guides, install separating plate (2) as a set.

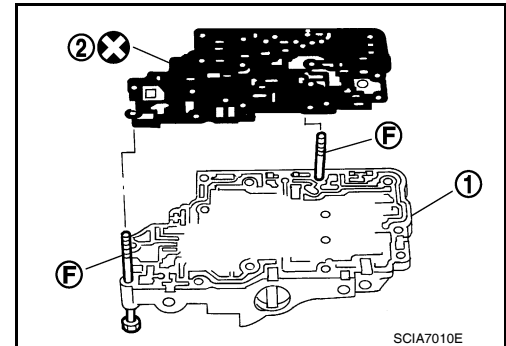

- c. Install pilot filter (1) on control valve upper body (2).

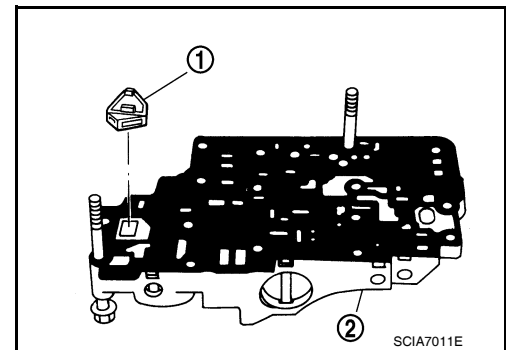

- d. Place control valve inter body as shown (side of control valve lower body face up). Install steel balls in their proper positions.

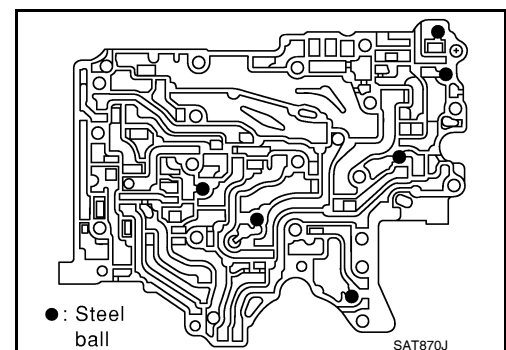

- e. Install control valve inter body (1) on control valve upper body (2) using reamer bolts (F) as guides.

CAUTION:

Be careful not to dislocate or drop steel balls.

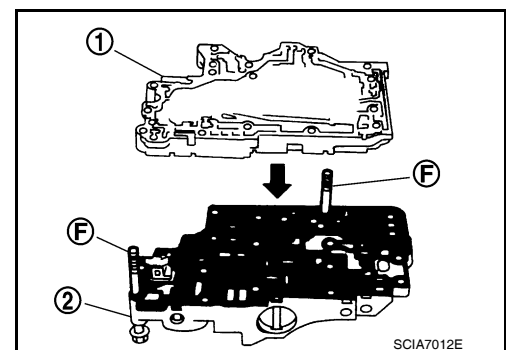

A
B
AT
D
E
F
G
H
I
J
K
L
M
N
O
P

REPAIR FOR COMPONENT PARTS

< SERVICE INFORMATION >

- f. Install check balls (1), line pressure relief valve springs (2) and torque converter pressure holding spring (3) in their proper positions in control valve lower body (4).

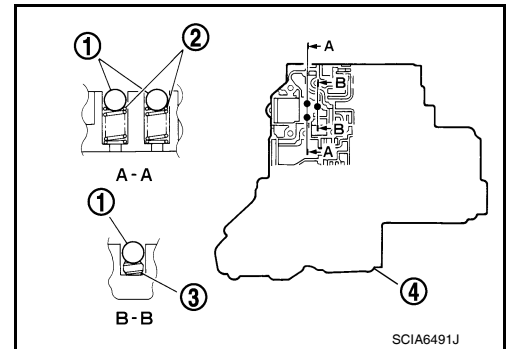

- g. Install bolts (E) from bottom of control valve lower body (1).
 Using bolts (E) as guides, install separating plate (2) as a set.
 h. Install support plates (3) on control valve lower body (1).

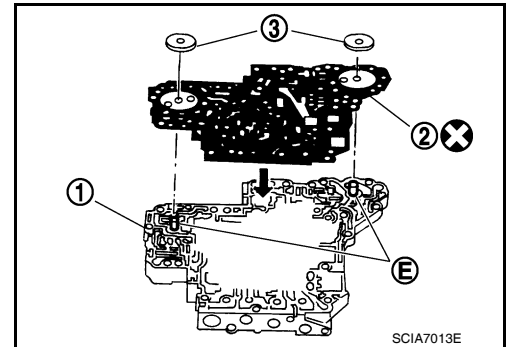

- i. Install control valve lower body (1) on control valve inter body (2) using reamer bolts (F) as guides, and tighten reamer bolts (F) slightly.

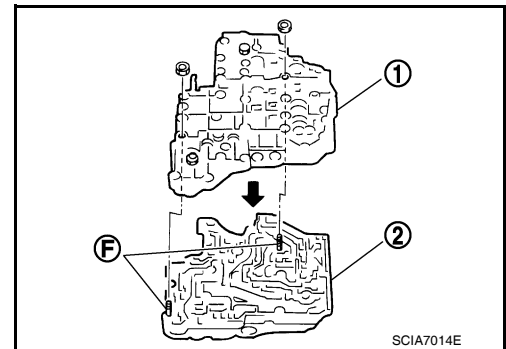

2. Install O-rings on solenoid valves and terminal body.

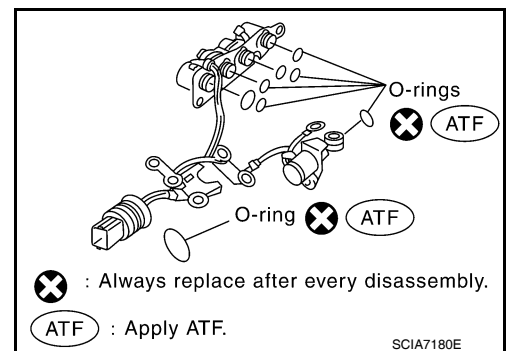

REPAIR FOR COMPONENT PARTS

< SERVICE INFORMATION >

3. Install and tighten bolts.
 - (1): Control valve upper body
 - (2): Control valve inter body
 - (3): Control valve lower body
 - (4): Support plate

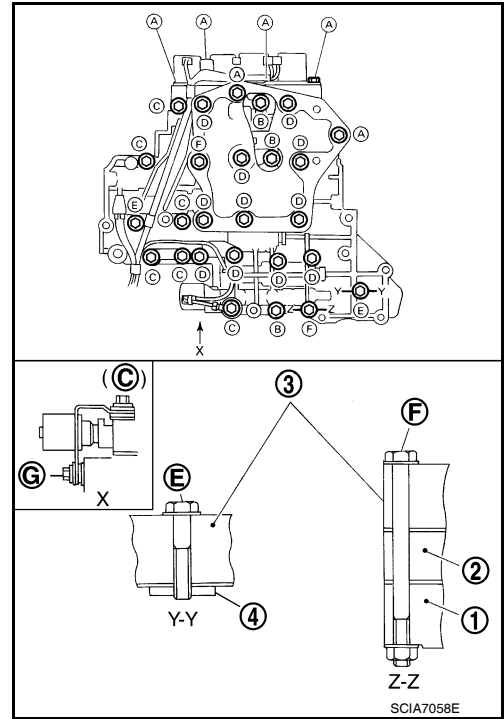

Bolt length, number and location:

Bolt symbol	A	B	C	D	E	F*	G
Bolt length "ℓ" [mm (in)] 	13.5 (0.531)	58.0 (2.283)	40.0 (1.575)	66.0 (2.598)	33.0 (1.299)	78.0 (3.071)	18.0 (0.709)
Number of bolts	6	3	6	11	2	2	1
Tightening torque [N·m (kg·m, in·lb)]	8.6 (0.88, 76)				5.0 (0.51, 44)	8.6 (0.88, 76)	

*: Reamer bolt and nut.

- a. Install and tighten bolts (B) to the specified torque.

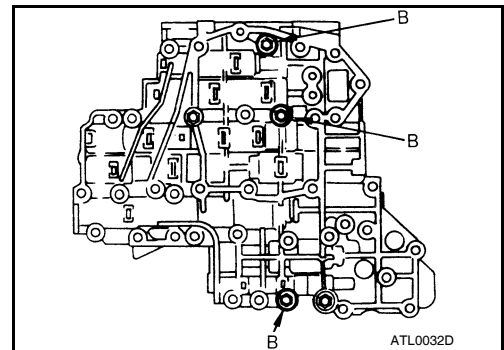

- b. Install solenoid valve assembly (1) on control valve assembly.
- c. Tighten bolts (A), (C) and (G) to the specified torque.

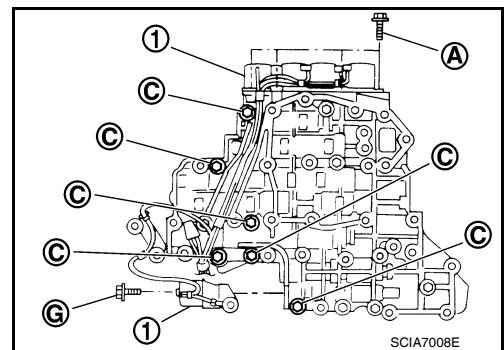

REPAIR FOR COMPONENT PARTS

< SERVICE INFORMATION >

- d. Remove reamer bolts (F), and then set oil strainer (1) on control valve assembly
- e. Install and tighten bolts (A), (D), reamer bolts (F) and nuts to the specified torque.

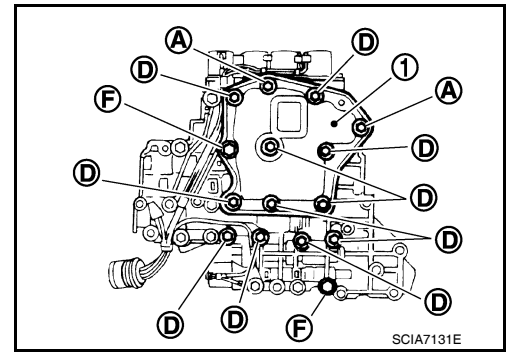

- f. Tighten bolts (E) to the specified torque.

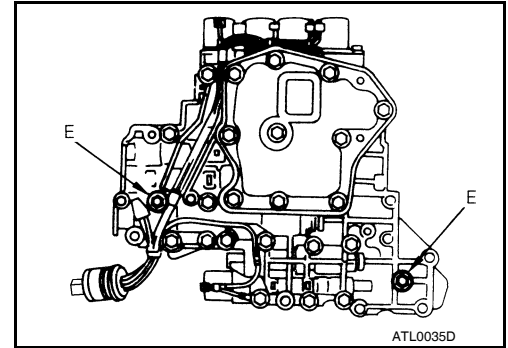

Control Valve Upper Body

COMPONENTS

INFOID:000000005928293

REPAIR FOR COMPONENT PARTS

< SERVICE INFORMATION >

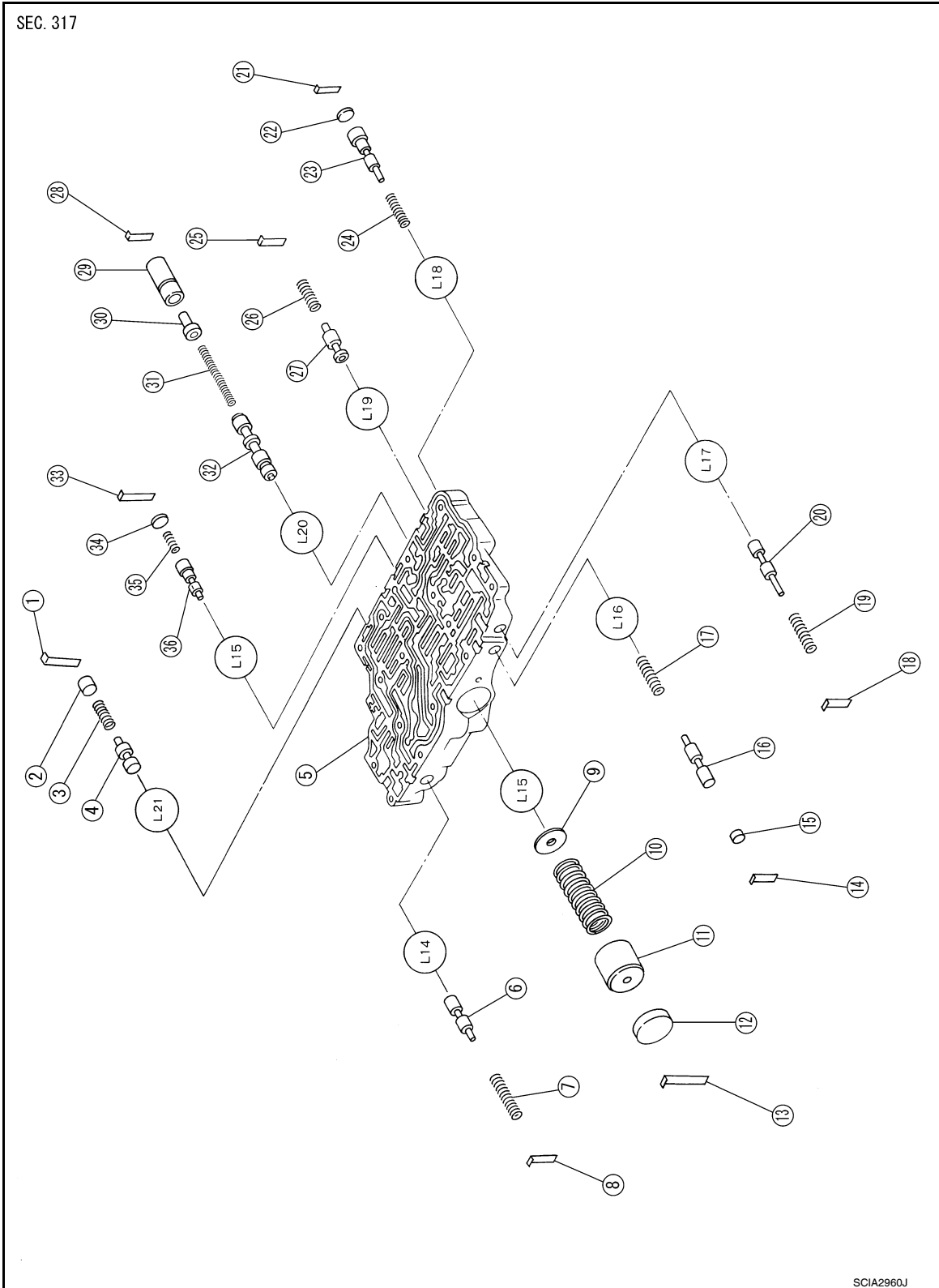

- | | | |
|-----------------------------------|-------------------------------|-----------------------------------|
| 1. Retainer plate | 2. Plug | 3. Cooler check valve spring |
| 4. Cooler check valve | 5. Control valve upper body | 6. Pilot valve |
| 7. Pilot valve spring | 8. Retainer plate | 9. 1-2 accumulator retainer plate |
| 10. 1-2 accumulator piston spring | 11. 1-2 accumulator piston | 12. Plug |
| 13. Retainer plate | 14. Retainer plate | 15. Plug |
| 16. 1st reducing valve | 17. 1st reducing valve spring | 18. Retainer plate |

REPAIR FOR COMPONENT PARTS

< SERVICE INFORMATION >

- | | | |
|--|---|--|
| 19. 3-2 timing valve spring | 20. 3-2 timing valve | 21. Retainer plate |
| 22. Plug | 23. Overrun clutch reducing valve | 24. Overrun clutch reducing valve spring |
| 25. Retainer plate | 26. Torque converter relief valve spring | 27. Torque converter relief valve |
| 28. Retainer plate | 29. Sleeve | 30. Plug |
| 31. Torque converter clutch control valve spring | 32. Torque converter clutch control valve | 33. Retainer plate |
| 34. Plug | 35. 1-2 accumulator valve spring | 36. 1-2 accumulator valve |

DISASSEMBLY

1. Remove valves at retainer plates.

CAUTION:

Do not use a magnetic pick-up tool.

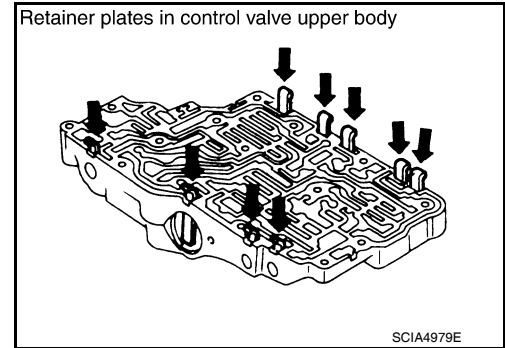

- a. Use a suitable tool (A) to remove retainer plates (1).

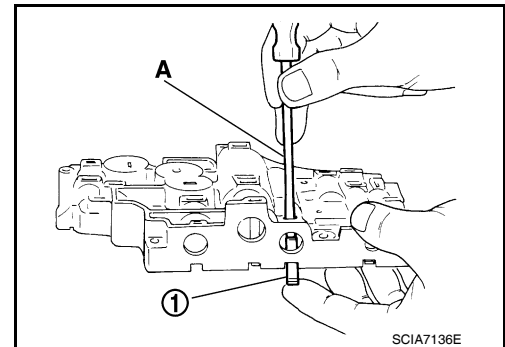

- b. Remove retainer plates (1) while holding spring, plugs (2) or sleeves using a suitable tool (A).

CAUTION:

Remove plugs (2) slowly to prevent internal parts from jumping out.

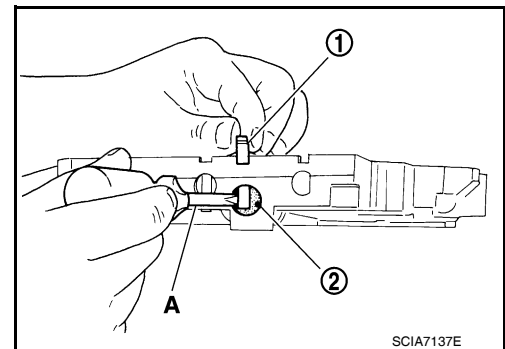

REPAIR FOR COMPONENT PARTS

< SERVICE INFORMATION >

c. Place mating surface of valve body face down, and remove internal parts.

CAUTION:

- If a valve is hard to remove, place valve body face down and lightly tap it with a soft hammer.
- Be careful not to drop or damage valves and sleeves.

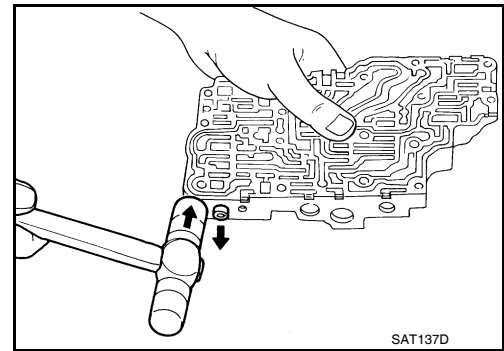

INSPECTION

Valve Springs

- Check each valve spring for damage or deformation. Also measure free length and outer diameter. Refer to [AT-375, "Control Valves"](#).
- Replace valve springs if deformed or fatigued.

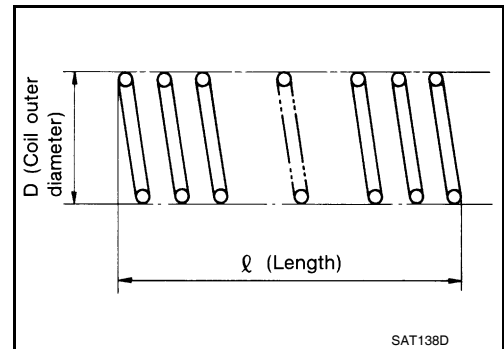

Control Valves

Check sliding surfaces of valves, sleeves and plugs. Replace if necessary.

ASSEMBLY

CAUTION:

- Apply ATF to all components before installation.
- Lay control valve body down when installing valves. Do not stand control valve body upright.

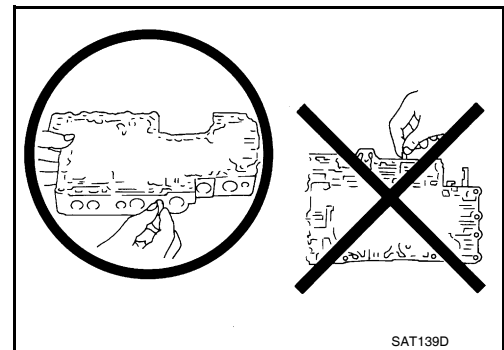

Lubricate control valve body and all valves with ATF. Install control valves by sliding them carefully into their bores.

CAUTION:

- Install each control valve one by one.
- Install control valves after checking, because some of them are similar.
- Be careful not to scratch or damage valve body.

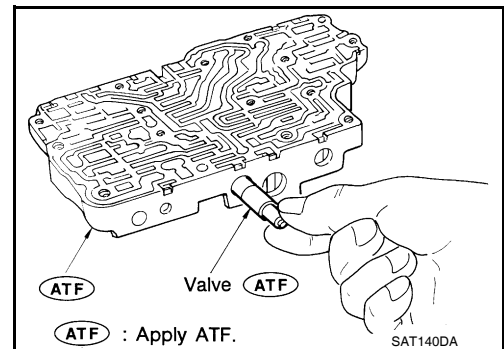

REPAIR FOR COMPONENT PARTS

< SERVICE INFORMATION >

- Wrap a small suitable tool (A) with vinyl tape and use it to insert valves into their proper positions.

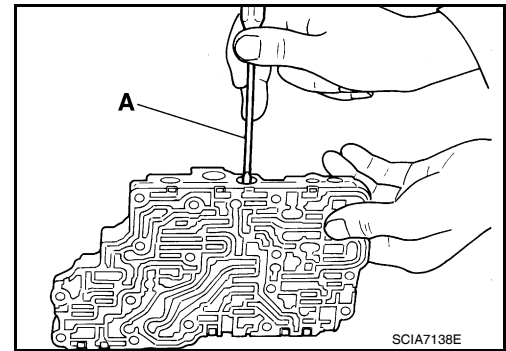

- Install retainer plates (1).
- While pushing plug or return spring, install retainer plate (1) using a suitable tool (A).

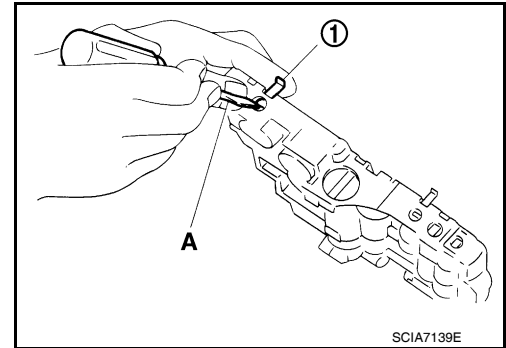

1-2 Accumulator Valve

- Install 1-2 accumulator valve (1), 1-2 accumulator valve spring and plug. Align 1-2 accumulator retainer plate (2) from opposite side of control valve body.
- Install 1-2 accumulator valve piston spring (3), 1-2 accumulator piston (4), plug (5) and retainer plate (6).

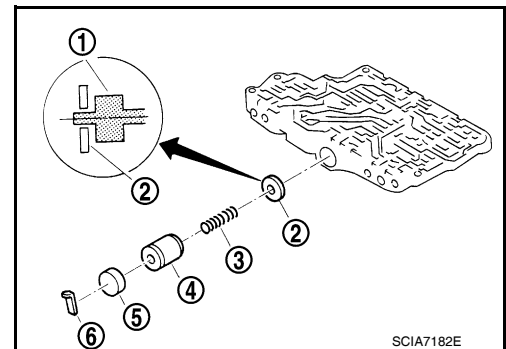

Retainer Plate (Control Valve Upper Body)

Install proper retainer plates.

Unit: mm (in)

Location	Retainer plate designation	Width "A"	Length "B"
L14	Pilot valve	6.0 (0.236)	21.5 (0.846)
L15	1-2 accumulator valve		40.5 (1.594)
	1-2 accumulator piston		
L16	1st reducing valve		21.5 (0.846)
L17	3-2 timing valve		24.0 (0.945)
L18	Overrun clutch reducing valve		21.5 (0.846)
L19	Torque converter relief valve		28.0 (1.102)
L20	Torque converter clutch control valve		24.0 (0.945)
L21	Cooler check valve		

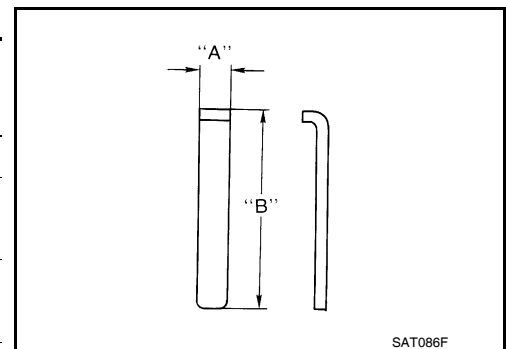

Control Valve Lower Body

INFOID:000000005928294

COMPONENTS

REPAIR FOR COMPONENT PARTS

< SERVICE INFORMATION >

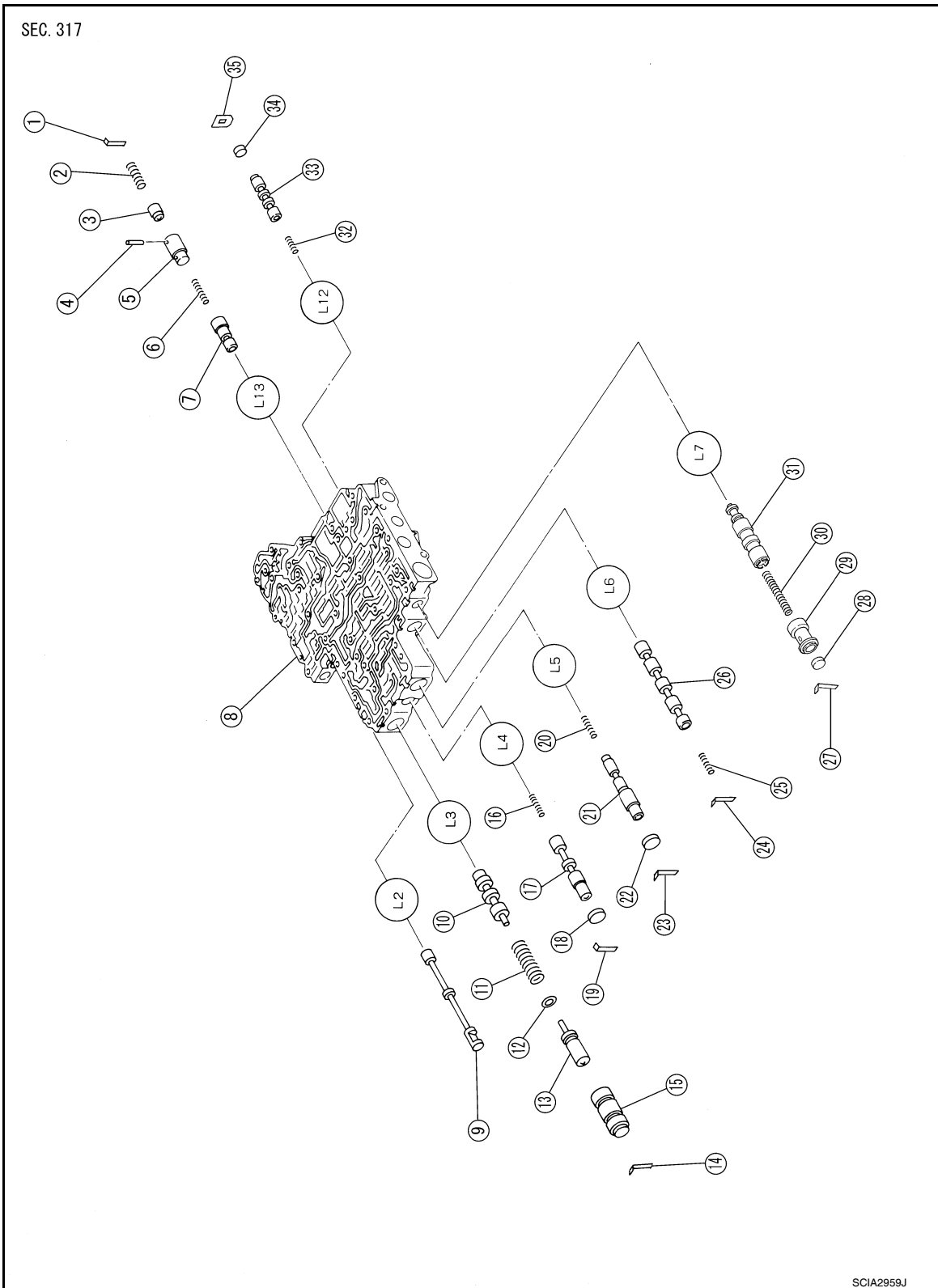

- | | | |
|---|-------------------------------------|-----------------------------------|
| 1. Retainer plate | 2. Pressure modifier piston spring | 3. Pressure modifier piston |
| 4. Parallel pin | 5. Sleeve | 6. Pressure modifier valve spring |
| 7. Pressure modifier valve | 8. Control valve lower body | 9. Manual valve |
| 10. Pressure regulator valve | 11. Pressure regulator valve spring | 12. Spring seat |
| 13. Plug | 14. Retainer plate | 15. Sleeve |
| 16. Overrun clutch control valve spring | 17. Overrun clutch control valve | 18. Plug |

A
B
AT
D
E
F
G
H
I
J
K
L
M
N
O
P

REPAIR FOR COMPONENT PARTS

< SERVICE INFORMATION >

- | | | |
|--------------------------|--------------------------------------|-------------------------------|
| 19. Retainer plate | 20. Accumulator control valve spring | 21. Accumulator control valve |
| 22. Plug | 23. Retainer plate | 24. Retainer plate |
| 25. Shift valve A spring | 26. Shift valve A | 27. Retainer plate |
| 28. Plug | 29. Shuttle plug | 30. Shuttle valve spring |
| 31. Shuttle valve | 32. Shift valve B spring | 33. Shift valve B |
| 34. Plug | 35. Retainer plate | |

DISASSEMBLY

Remove valves at retainer plate.

For removal procedures, refer to [AT-290, "Control Valve Upper Body"](#).

Retainer plates in control valve lower body

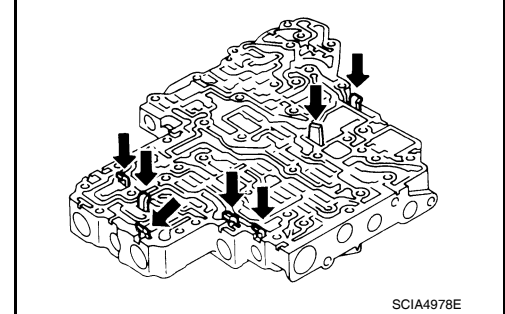

INSPECTION

Valve Springs

- Check each valve spring for damage or deformation. Also measure free length and outer diameter. Refer to [AT-375, "Control Valves"](#).
- Replace valve springs if deformed or fatigued.

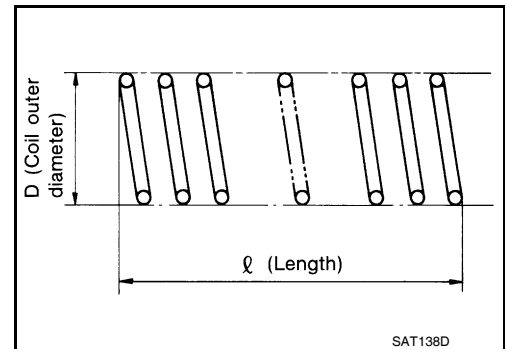

Control Valves

Check sliding surfaces of control valves, sleeves and plugs for damage. Replace if necessary.

ASSEMBLY

CAUTION:

- Apply ATF to all components before installation.
- Lay control valve body down when installing valves. Do not stand control valve body upright.

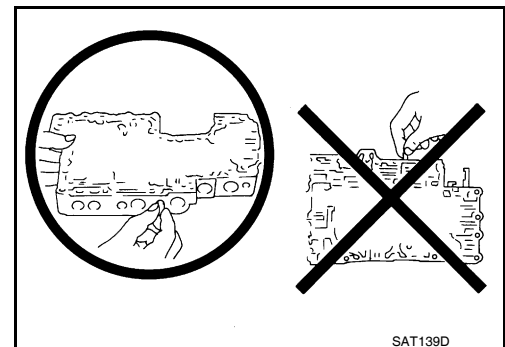

REPAIR FOR COMPONENT PARTS

< SERVICE INFORMATION >

Install control valves.

For installation procedures, refer to [AT-290, "Control Valve Upper Body"](#).

Retainer plates in control valve lower body

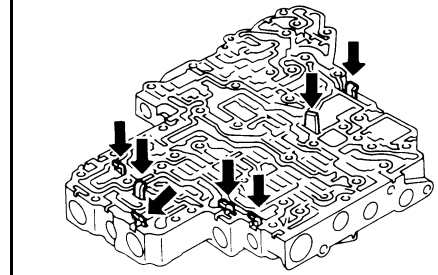

SCIA4978E

Retainer Plate (Control Valve Lower Body)

Install proper retainer plates.

Unit: mm (in)

Location	Retainer plate designation	Width "A"	Length "B"	Type
L3	Pressure regulator valve	6.0 (0.236)	28.0 (1.102)	I
L4	Overrun clutch control valve			
L5	Accumulator control valve			
L6	Shift valve A			
L7	Shuttle valve			
L12	Shift valve B	17.0 (0.669)	24.0 (0.945)	II
L13	Pressure modifier valve	6.0 (0.236)	28.0 (1.102)	I

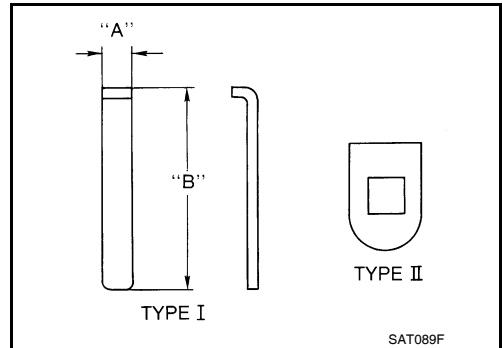

SAT089F

Reverse Clutch

INFOID:000000005928295

COMPONENTS

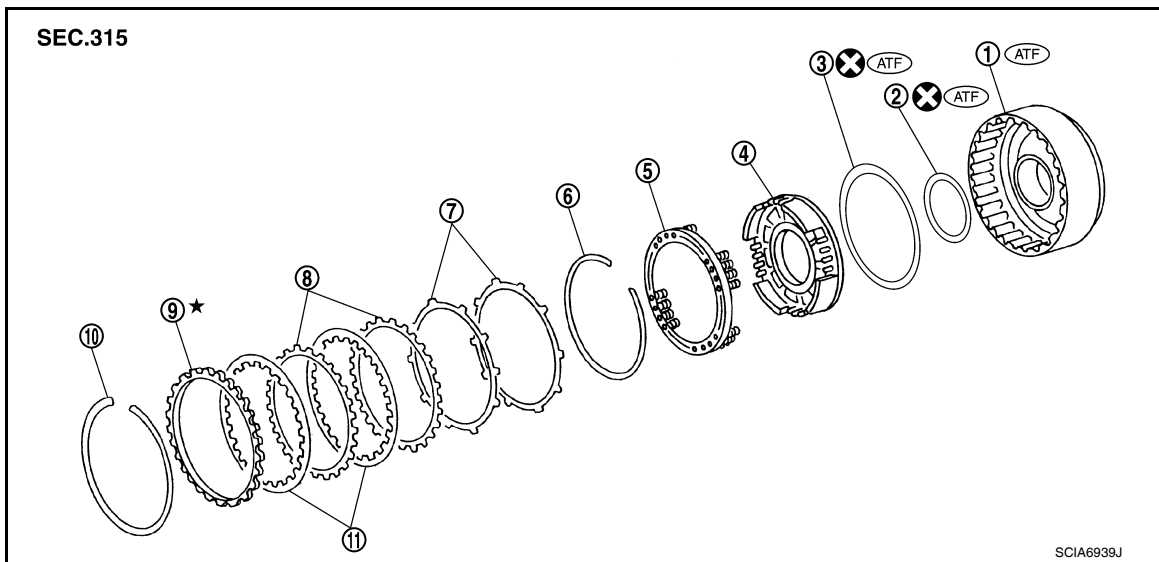

SCIA6939J

- | | | |
|--------------------------|-----------------------------|--------------------|
| 1. Reverse clutch drum | 2. D-ring | 3. Seal lip |
| 4. Reverse clutch piston | 5. Spring retainer assembly | 6. Snap ring |
| 7. Dish plate | 8. Driven plate | 9. Retaining plate |
| 10. Snap ring | 11. Drive plate | |

DISASSEMBLY

REPAIR FOR COMPONENT PARTS

< SERVICE INFORMATION >

1. Check operation of reverse clutch
 - a. Install seal rings to drum support of oil pump assembly, and set reverse clutch assembly.
 - b. Apply compressed air into the oil hole at the location as shown.
 - c. Check to see that retaining plate moves to snap ring.
 - d. If retaining plate does not contact snap ring:
 - D-ring might be damaged.
 - Seal lip might be damaged.
 - Fluid might be leaking past piston check ball.

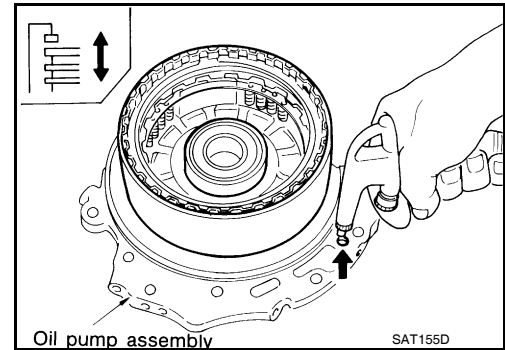

2. Remove snap ring (1) using a suitable tool (A).
3. Remove retaining plate, drive plates, driven plates and dish plates.

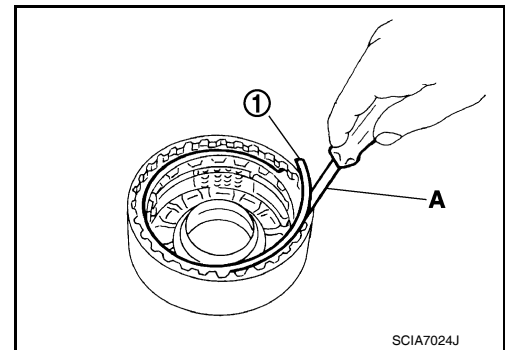

4. Set Tool (A) on spring retainer assembly, and remove snap ring (1) from reverse clutch drum while compressing spring retainer assembly.

Tool number: KV31103200 (J-39186)

CAUTION:
Set SST directly over return springs.

5. Remove spring retainer assembly from reverse clutch drum.
CAUTION:
Do not remove return springs from spring retainer.

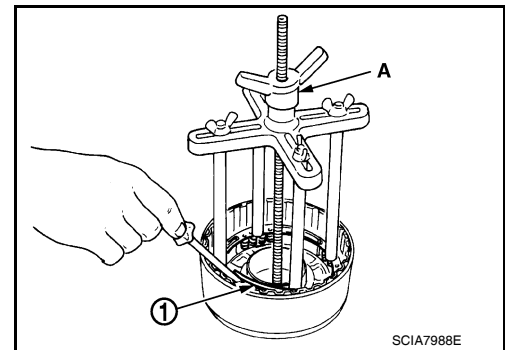

6. Install seal rings to drum support of oil pump assembly (1), and set reverse clutch drum (2). Then apply compressed air into the oil hole at the location as shown in the figure to remove reverse clutch piston (3) from reverse clutch drum (2).

CAUTION:
Do not flow air in too quickly or reverse clutch piston (3) and ATF could jump out. Carefully flow air in little by little while protecting with lint-free cloth.

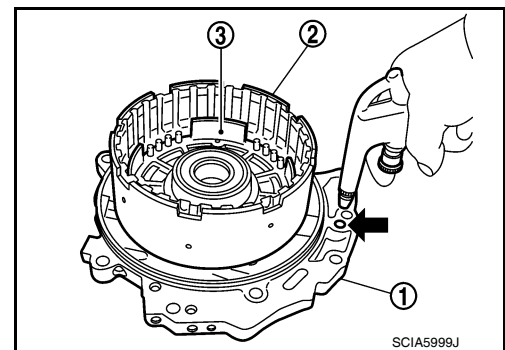

REPAIR FOR COMPONENT PARTS

< SERVICE INFORMATION >

7. Remove D-ring (1) and seal lip (2) from reverse clutch piston (3).

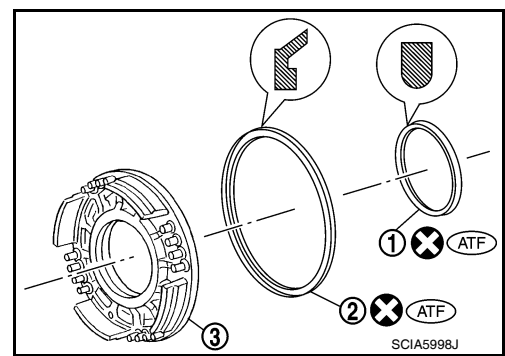

INSPECTION

Reverse Clutch Snap Ring

Check for deformation, fatigue or damage. Replace if necessary.

Reverse Clutch Drive Plates

- Check facing for burns, cracks or damage. Replace if necessary.
- Measure thickness of facing.

Thickness of drive plate

Standard and allowable limit:

Refer to [AT-376, "Clutches and Brakes"](#).

CAUTION:

- Measure the thickness at 3 locations and find the average.
- Inspect all drive plates.
- Replace if the thickness is below the allowable limit.

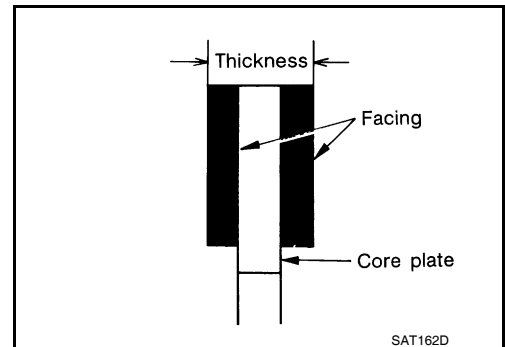

Reverse Clutch Dish Plates

- Check for deformation or damage.
- Measure thickness (t) of dish plate. Replace if damaged, deformed or worn.

Thickness of dish plate (t): 2.87 mm (0.1130 in)

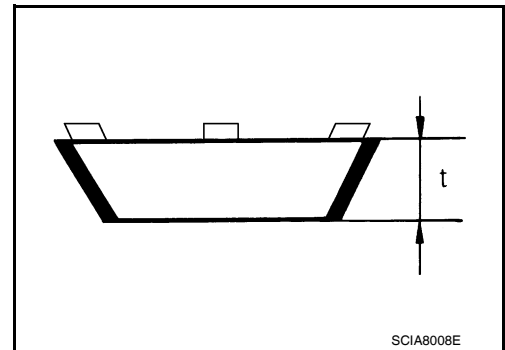

Reverse Clutch Spring Retainer Assembly

Measure length (L) of spring retainer assembly. Replace if damaged, deformed or worn.

Length (L) : 20.1 mm (0.791 in)

CAUTION:

Do not remove return springs (A) from spring retainer (B)

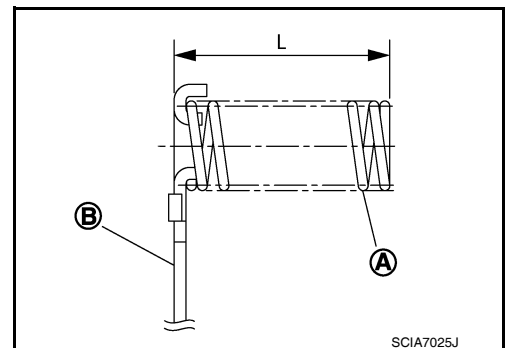

Reverse Clutch Piston

REPAIR FOR COMPONENT PARTS

< SERVICE INFORMATION >

- Make sure that check balls are not fixed.
- Apply compressed air to check ball oil hole opposite from return spring. Make sure there is no air leakage.
- Apply compressed air to oil hole on return spring side to make sure that air leaks past ball.

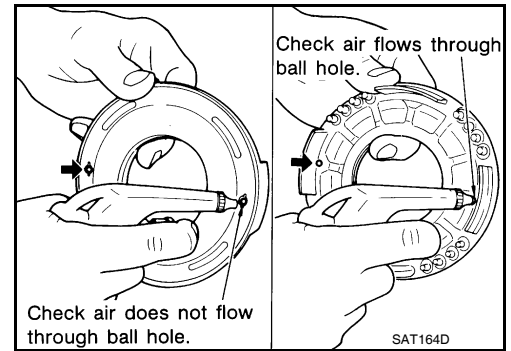

Reverse Clutch Drum

Check for deformation or damage. Replace if necessary.

ASSEMBLY

1. Install D-ring (1) and seal lip (2) on reverse clutch piston (3).

CAUTION:

Be careful with the direction of seal lip (2).

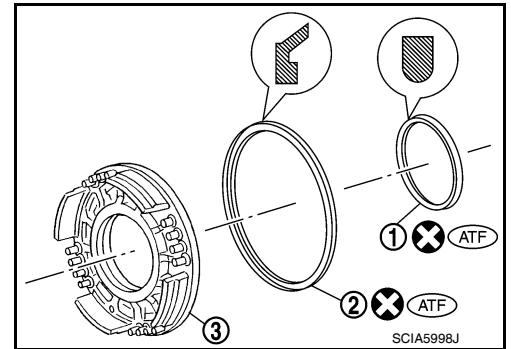

2. Install reverse clutch piston by turning it slowly.

CAUTION:

Apply ATF to inner surface of reverse clutch drum.

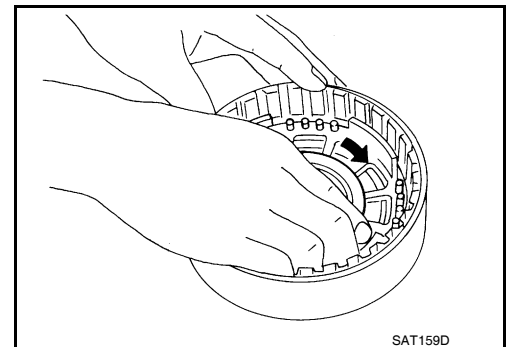

3. Install spring retainer assembly (1) to reverse clutch piston (2).

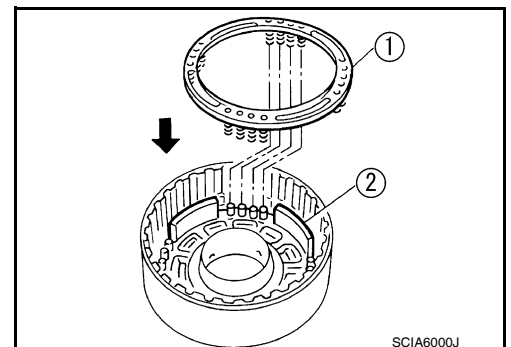

REPAIR FOR COMPONENT PARTS

< SERVICE INFORMATION >

- Set Tool (A) on spring retainer assembly, and install snap ring (1) while compressing spring retainer assembly.

Tool number: KV31103200 (J-39186)

CAUTION:
Set SST directly over return springs.

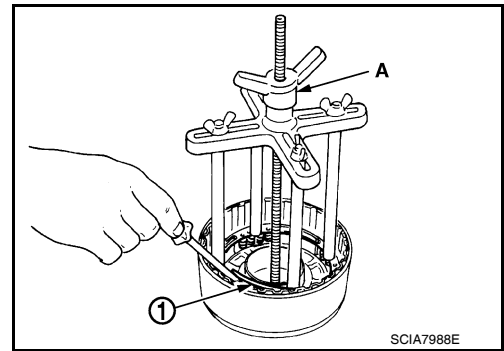

- Install dish plates, driven plates, drive plates and retaining plate.

- Snap ring
- Retaining plate
- Drive plate
- Driven plate
- Dish plate

Drive plate/Driven plate: 2/2

CAUTION:
Be careful with the order of plates.

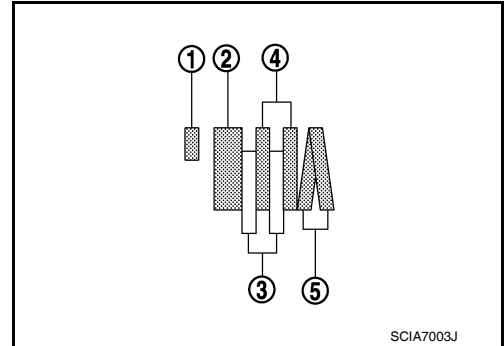

NOTE:

Install two dish plates fitting each installation direction with reverse clutch drum groove displaced slightly.

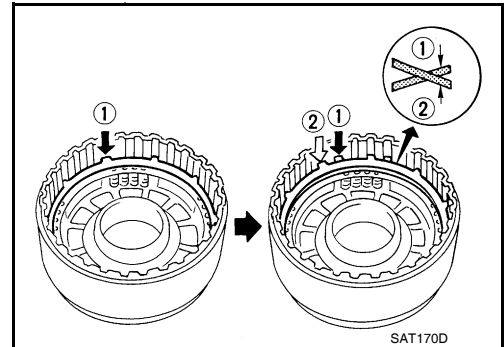

- Install snap ring (1) using a suitable tool (A).

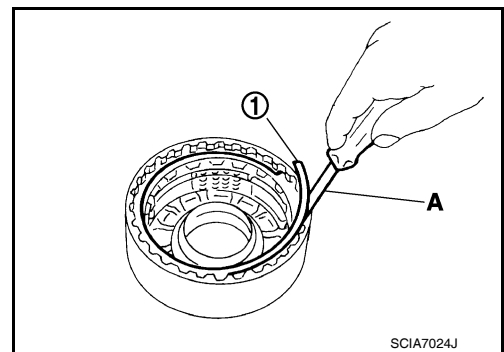

REPAIR FOR COMPONENT PARTS

< SERVICE INFORMATION >

7. Measure clearance between retaining plate and snap ring using feeler gauge. If not within allowable limit, select proper retaining plate. Refer to "Parts Information" for retaining plate selection.

Specified clearance

Standard and allowable limit:

Refer to [AT-376, "Clutches and Brakes"](#).

8. Check operation of reverse clutch.

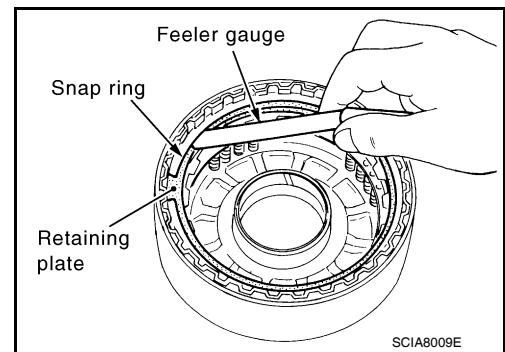

INFOID:000000005928296

High Clutch

COMPONENTS

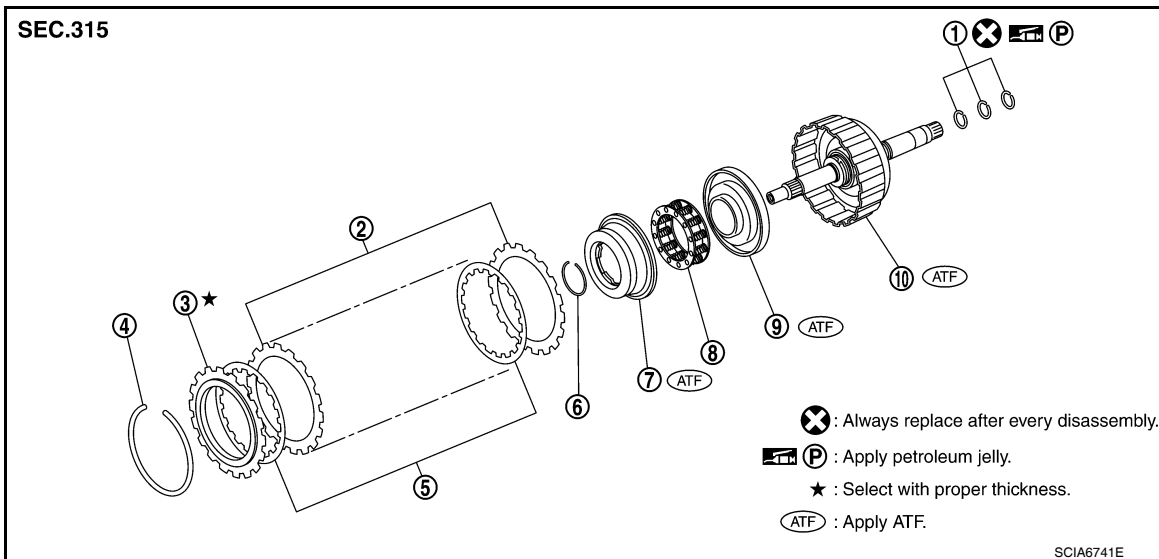

- | | | |
|---|-----------------------------|-----------------------|
| 1. Seal ring | 2. Driven plate | 3. Retaining plate |
| 4. Snap ring | 5. Drive plate | 6. Snap ring |
| 7. Cancel cover | 8. Spring retainer assembly | 9. High clutch Piston |
| 10. Input shaft assembly (high clutch drum) | | |

DISASSEMBLY

1. Check operation of high clutch.
 - a. Apply compressed air into the oil hole (A) of input shaft assembly (high clutch drum) at the location as shown.

CAUTION:
Block the oil hole (A) on the opposite side with lint-free cloth (B).
 - b. Check to see that retaining plate moves to snap ring.
 - c. If retaining plate does not contact snap ring:
 - High clutch piston seal might be damaged.

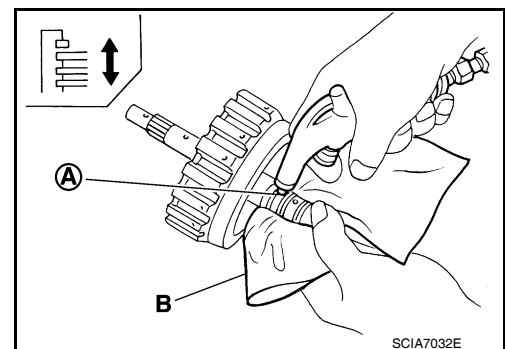

REPAIR FOR COMPONENT PARTS

< SERVICE INFORMATION >

- Remove seal rings from input shaft assembly (high clutch drum).

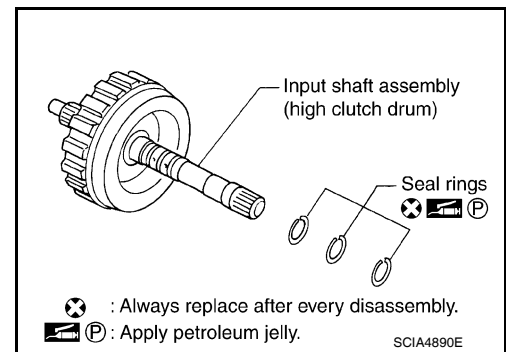

- Remove snap ring using a flat-bladed screwdriver.
- Remove retaining plate, drive plates and driven plates.

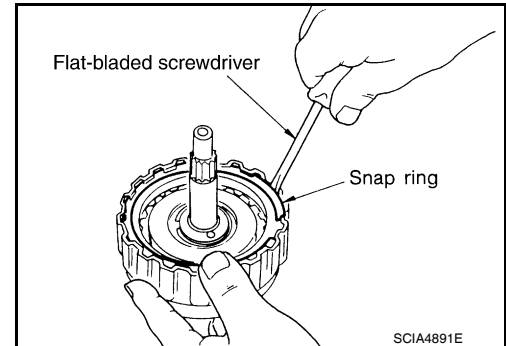

- Set Tool (A) on cancel cover, and remove snap ring (1) from input shaft assembly (high clutch drum) while compressing spring retainer assembly.

Tool number **A: KV31103200 (J-39186)**

CAUTION:

Do not expand snap ring (1) excessively.

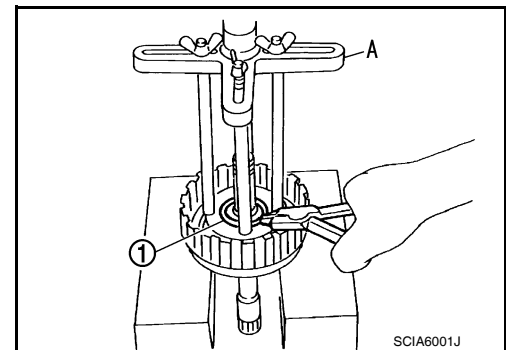

- Remove cancel cover (1) and spring retainer assembly (2) from input shaft assembly (high clutch drum) (3).

CAUTION:

Do not remove return springs from spring retainers.

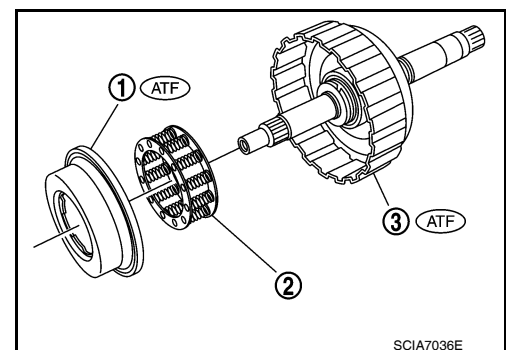

- Apply compressed air into the oil hole (A) at the location as shown to remove high clutch piston from input shaft assembly (high clutch drum).

CAUTION:

- Do not blow air in too quickly, or high clutch piston and ATF could jump out. Carefully blow air little by little while protecting with lint-free cloth (B).
- Block the oil hole on the opposite side with lint-free cloth (B).

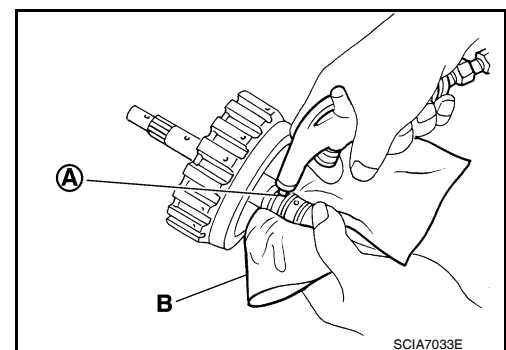

REPAIR FOR COMPONENT PARTS

< SERVICE INFORMATION >

INSPECTION

High Clutch Snap Ring

Check for deformation, fatigue or damage. Replace if necessary.

High Clutch Drive Plates

- Check facing for burns, cracks or damage. Replace if necessary.
- Measure thickness of facing.

Thickness of drive plate

Standard and allowable limit:

Refer to [AT-376, "Clutches and Brakes"](#).

CAUTION:

- Measure the thickness at 3 locations and find the average.
- Inspect all drive plates.
- Replace if the thickness is below the allowable limit.

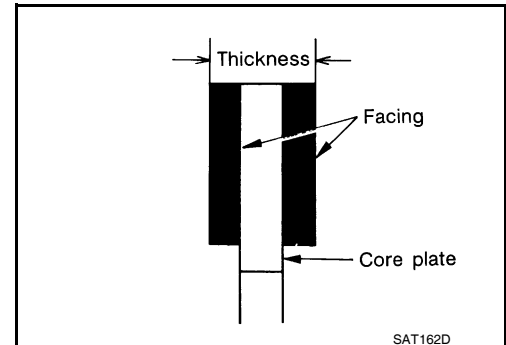

High Clutch Spring Retainer Assembly

Check length (L) of springs retainer assembly. Replace if damaged, deformed or worn.

Length (L) : 20.6 mm (0.811 in)

CAUTION:

Do not remove return springs (A) from spring retainers (B).

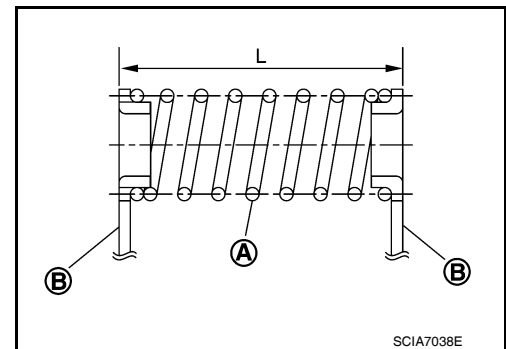

High Clutch Piston and Cancel Cover

Check for deformation or damage. Replace if necessary.

Input Shaft Assembly (High Clutch Drum)

Check for deformation or damage. Replace if necessary.

Seal Ring Clearance

- Install new seal rings onto input shaft assembly (high clutch drum).
- Measure clearance between seal ring and ring groove.

Standard clearance and allowable limit:

Refer to [AT-378, "Input Shaft"](#).

- If not within allowable limit, replace input shaft assembly (high clutch drum).

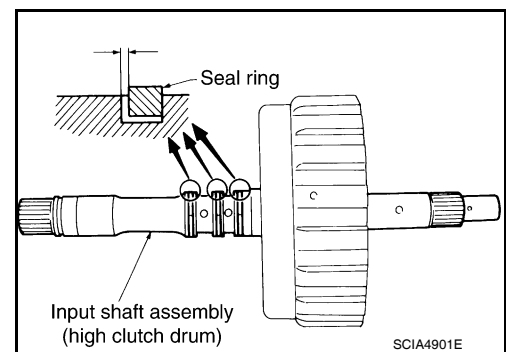

ASSEMBLY

REPAIR FOR COMPONENT PARTS

< SERVICE INFORMATION >

1. Install high clutch piston by turning it slowly.

CAUTION:

Apply ATF to inner surface of input shaft assembly (high clutch drum) and high clutch piston.

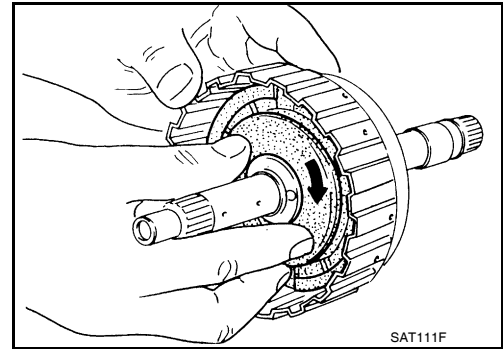

2. Install spring retainer assembly (2) and cancel cover (1) on input shaft assembly (high clutch drum) (3).

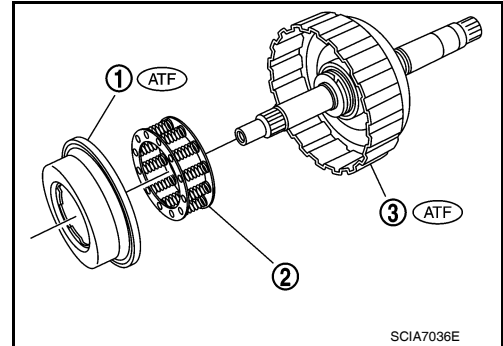

3. Set Tool (A) on cancel cover, and install snap ring (1) to input shaft assembly (high clutch drum) while slowly compressing spring retainer assembly.

Tool number **A: KV31103200 (J-39186)**

CAUTION:

- Do not expand snap ring (1) excessively.
- Install spring retainer assembly without tilting.

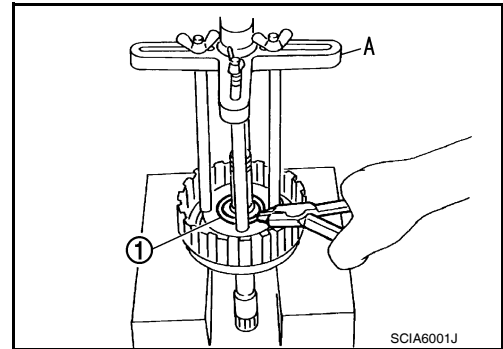

- Do not align snap ring gap with cancel cover stopper.

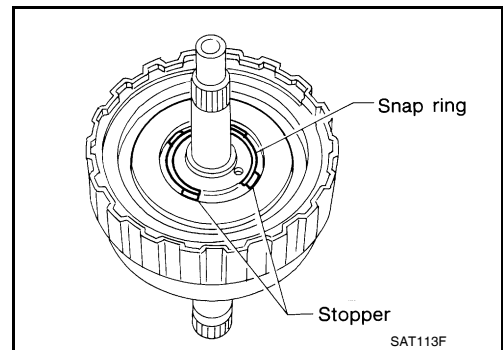

4. Install driven plates, drive plates and retaining plate.

A
B
AT
D
E
F
G
H
I
J
K
L
M
N
O
P

REPAIR FOR COMPONENT PARTS

< SERVICE INFORMATION >

- HR16DE engine models

- (1): Snap ring
- (2): Retaining plate
- (3): Drive plate
- (4): Driven plate

Drive plate/Driven plate: 3/5

CAUTION:

Be careful with the order and direction of plates.

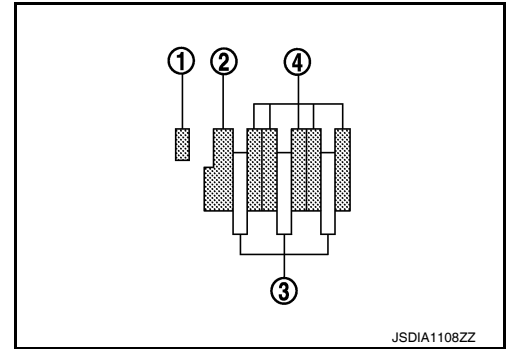

- MR18DE engine models

- (1): Snap ring
- (2): Retaining plate
- (3): Drive plate
- (4): Driven plate
- (5): Driven plate

Drive plate/Driven plate: 4/7 (1+6)

CAUTION:

Be careful with the order and direction of plates.

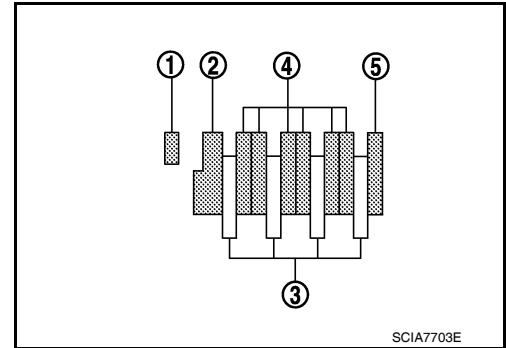

5. Install snap ring using a flat-bladed screwdriver.

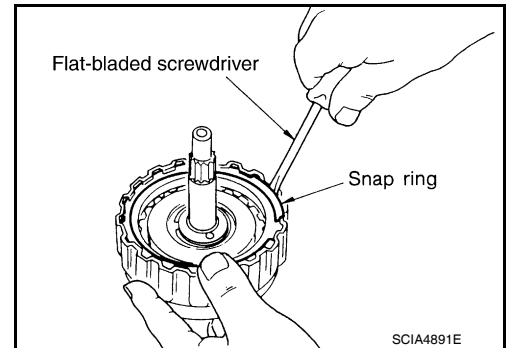

6. Set dial indicator (A) on retaining plate (1), and measure clearance between retaining plate (1) and snap ring (2). If not within allowable limit, select proper retaining plate (1). Refer to "Parts Information" for retaining plate selection.

Specified clearance

Standard and allowable limit:

Refer to [AT-376, "Clutches and Brakes"](#).

7. Check operation of high clutch.

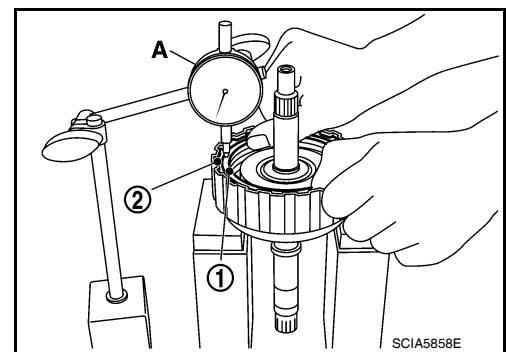

8. Install seal rings to input shaft assembly (high clutch drum).

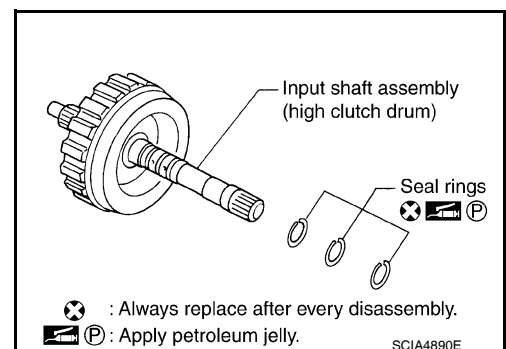

REPAIR FOR COMPONENT PARTS

< SERVICE INFORMATION >

CAUTION:

Roll paper around seal rings to prevent seal rings from spreading.

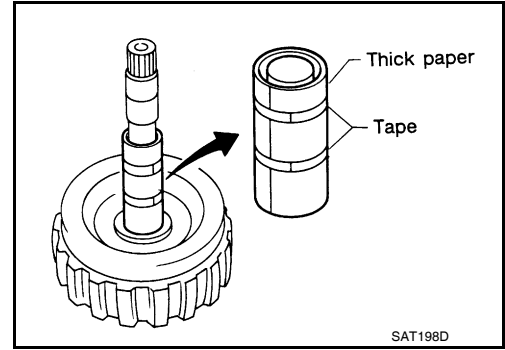

SAT198D

Forward and Overrun Clutches

INFOID:000000005928297

COMPONENTS

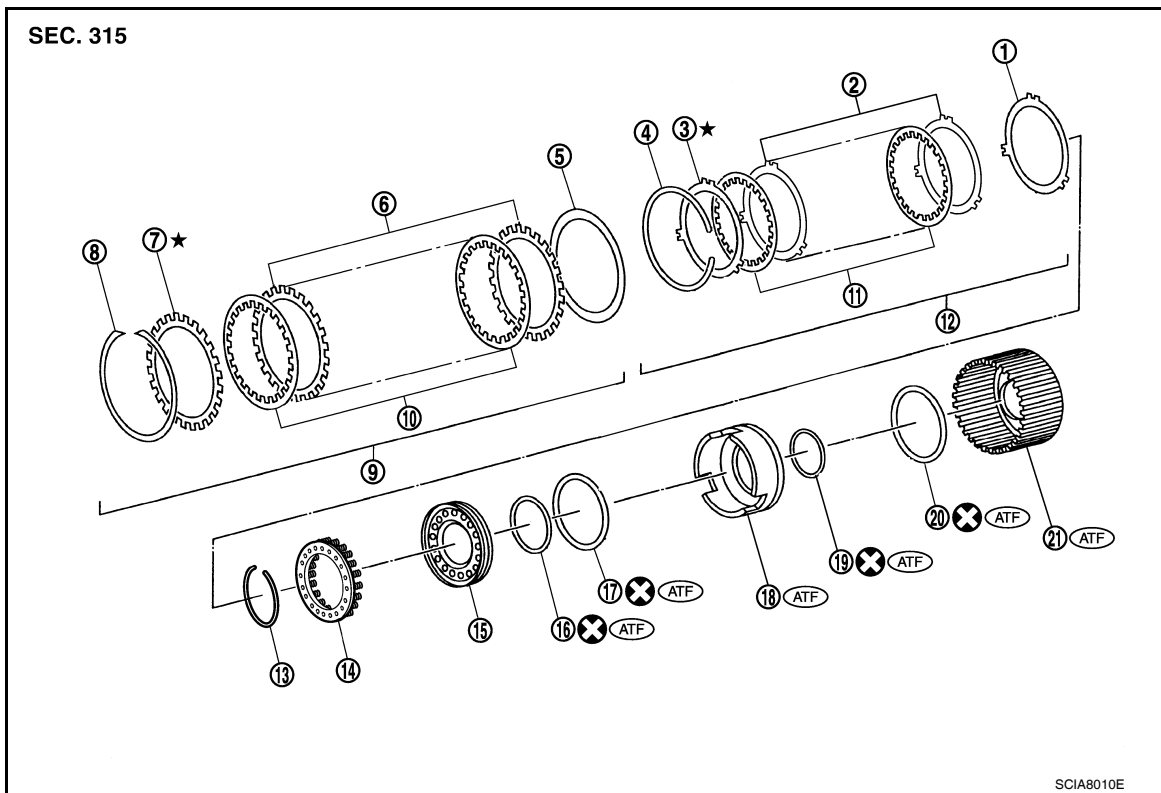

SCIA8010E

- | | | |
|--------------------|------------------------------|---------------------------|
| 1. Dish plate | 2. Driven plate | 3. Retaining plate |
| 4. Snap ring | 5. Dish plate | 6. Driven plate |
| 7. Retaining plate | 8. Snap ring | 9. Forward clutch |
| 10. Drive plate | 11. Drive plate | 12. Overrun clutch |
| 13. Snap ring | 14. Spring retainer assembly | 15. Overrun clutch piston |
| 16. D-ring | 17. Seal lip | 18. Forward clutch piston |
| 19. D-ring | 20. Seal lip | 21. Forward clutch drum |

DISASSEMBLY

1. Check operation of forward clutch.
 - a. Install seal rings to bearing retainer, and set forward clutch drum.

A
B
AT
D
E
F
G
H
I
J
K
L
M
N
O
P

REPAIR FOR COMPONENT PARTS

< SERVICE INFORMATION >

- b. Apply compressed air into oil hole of bearing retainer at the location as shown.
- c. Check to see that retaining plate moves to snap ring.
- d. If retaining plate does not contact snap ring:
 - D-ring might be damaged.
 - Seal lip might be damaged.
 - Fluid might be leaking past piston check ball.

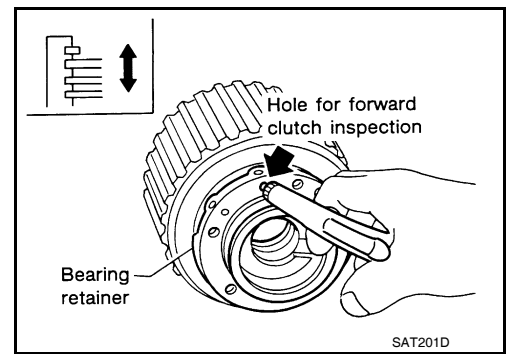

2. Check operation of overrun clutch.
 - a. Install seal rings to bearing retainer, and set forward clutch drum.
 - b. Apply compressed air into oil hole of bearing retainer at the location as shown.
 - c. Check to see that retaining plate moves to snap ring.
 - d. If retaining plate does not contact snap ring:
 - D-ring might be damaged.
 - Seal lip might be damaged.
 - Fluid might be leaking past piston check ball.

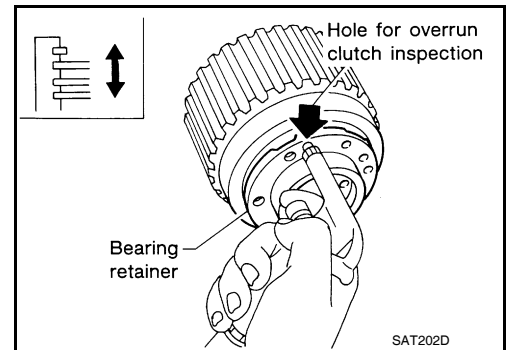

3. Remove snap ring for forward clutch from forward clutch drum using a flat-bladed screwdriver.
4. Remove retaining plate, drive plates, driven plates and dish plate for forward clutch.

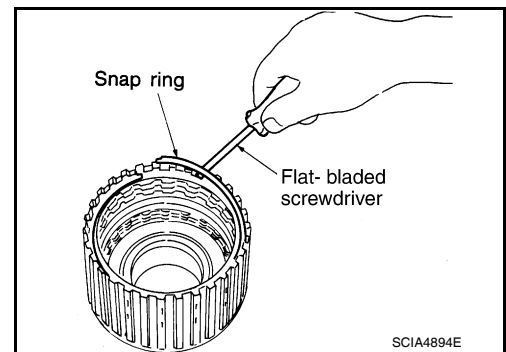

5. Remove snap ring for overrun clutch from forward clutch drum using a flat-bladed screwdriver.
6. Remove retaining plate, drive plates, driven plates and dish plate for overrun clutch.

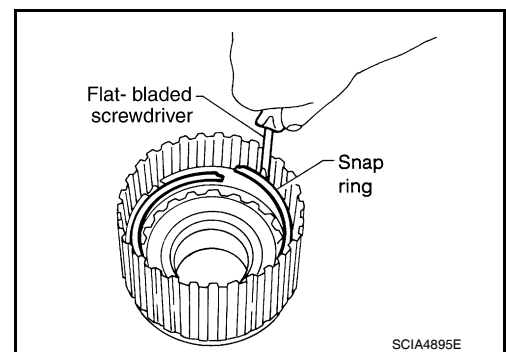

REPAIR FOR COMPONENT PARTS

< SERVICE INFORMATION >

7. Set Tool (A) on spring retainer assembly, and remove snap ring (1) from forward clutch drum while compressing spring retainer assembly.

Tool number : KV31103200 (J-39186)

CAUTION:

- Set Tool directly over return springs.
- Do not expand snap ring excessively.

8. Remove spring retainer assembly from forward clutch drum.

CAUTION:

Do not remove return springs from spring retainer.

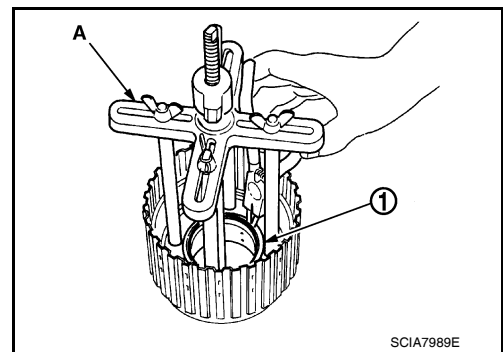

9. Install seal rings to bearing retainer (1), and set forward clutch drum. Then apply compressed air into the oil hole at the location as shown to remove overrun clutch piston from forward clutch piston.

CAUTION:

Do not blow air in too quickly, or overrun clutch piston and ATF could jump out. Carefully blow air little by little while protecting with lint-free cloth.

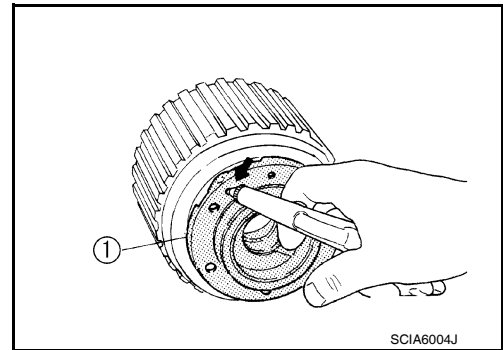

10. Install seal rings to bearing retainer (1), and set forward clutch drum. Then apply compressed air into the oil hole at the location as shown to remove forward clutch piston from forward clutch drum.

CAUTION:

Do not blow air in too quickly, or forward clutch piston and ATF could jump out. Carefully blow air little by little while protecting with lint-free cloth.

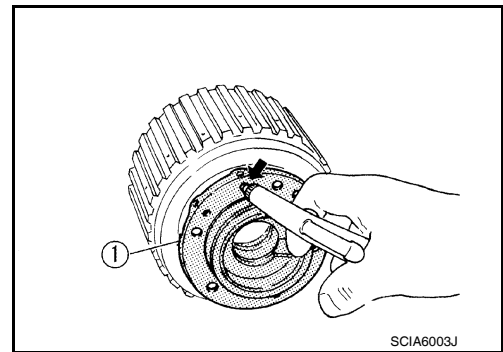

11. Remove seal lips (1) and D-rings (2) from forward clutch piston (3) and overrun clutch piston (4).

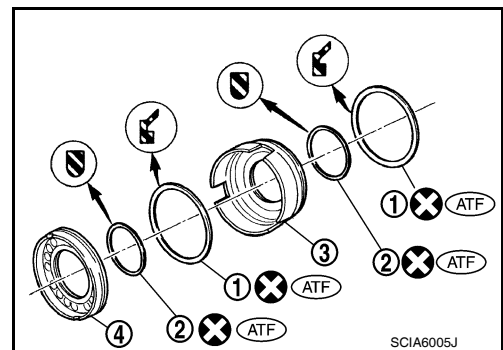

INSPECTION

Forward Clutch and Overrun Clutch Snap Rings

Check for deformation, fatigue or damage. Replace if necessary.

Forward Clutch and Overrun Clutch Drive Plates

REPAIR FOR COMPONENT PARTS

< SERVICE INFORMATION >

- Check facing for burns, cracks or damage. Replace if necessary.
- Measure thickness of facing.

Thickness of drive plate

Forward clutch

Standard and allowable limit:

Refer to [AT-376, "Clutches and Brakes"](#).

Overrun clutch

Standard and allowable limit:

Refer to [AT-376, "Clutches and Brakes"](#).

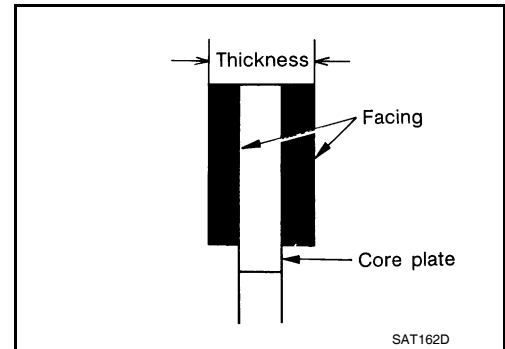

CAUTION:

- Measure the thickness at 3 locations and find the average.
- Inspect all drive plates.
- Replace if the thickness is below the allowable limit.

Forward Clutch and Overrun Clutch Dish Plates

- Check for deformation or damage.
- Measure thickness (t) of dish plate. Replace if damaged, deformed or worn.

Thickness of dish plate (t)

Forward clutch : 2.5 mm (0.098 in)

Overrun clutch : 2.15 mm (0.0846 in)

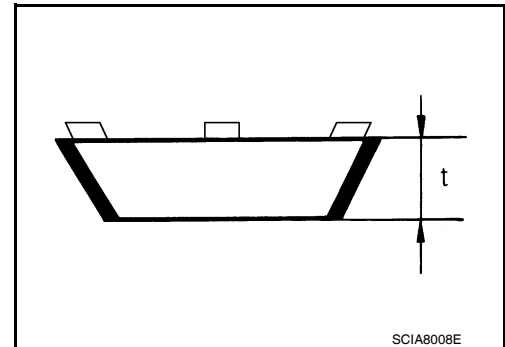

Forward Clutch and Overrun Clutch Spring Retainer Assembly

Check length (L) of spring retainer assembly. Replace if damaged, deformed or worn.

Length (L) : 27.7 mm (1.091 in)

CAUTION:

Do not remove return springs (A) from spring retainer (B)

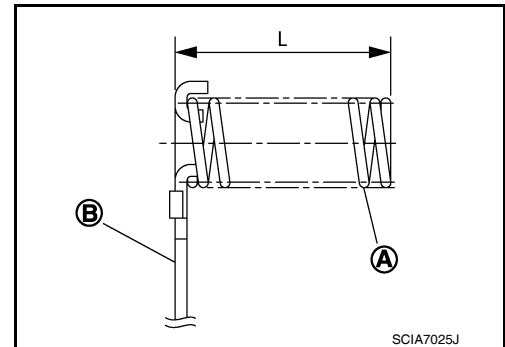

Forward Clutch Drum

- Make sure that check balls are not fixed.
- Apply compressed air to check ball oil hole from outside of forward clutch drum. Make sure air leaks past ball.
- Apply compressed air to oil hole from inside of forward clutch drum. Make sure there is no air leakage.

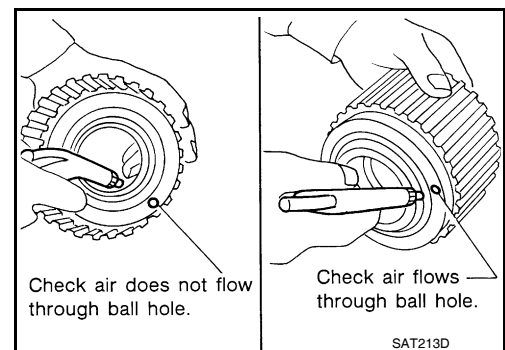

Overrun Clutch Piston

REPAIR FOR COMPONENT PARTS

< SERVICE INFORMATION >

- Make sure that check balls are not fixed.
- Apply compressed air to check ball oil hole opposite return spring. Make sure there is no air leakage.
- Apply compressed air to oil hole on return spring side. Make sure that air leaks through ball hole.

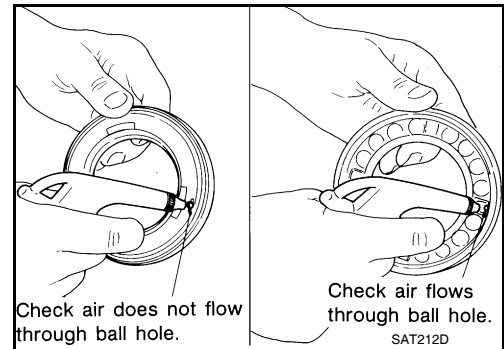

ASSEMBLY

1. Install seal lips (1) and D-rings (2) on forward clutch piston (3) and overrun clutch piston (4).

CAUTION:

Be careful with the direction of seal lips (1).

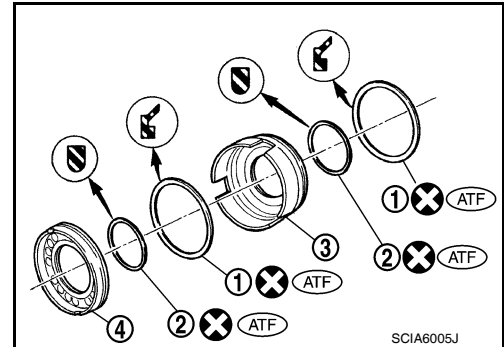

2. Install overrun clutch piston on forward clutch piston by turning it slowly.

CAUTION:

Apply ATF to inner surface of forward clutch piston.

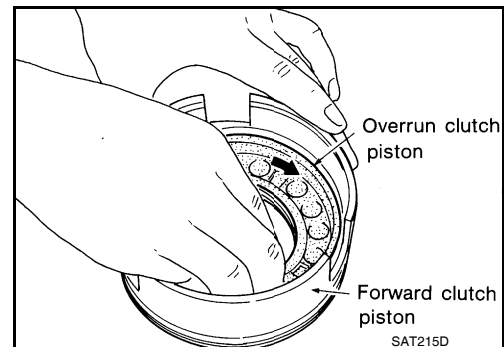

3. Install forward clutch piston with overrun clutch piston on forward clutch drum by turning it slowly.

CAUTION:

Apply ATF to inner surface of forward clutch drum.

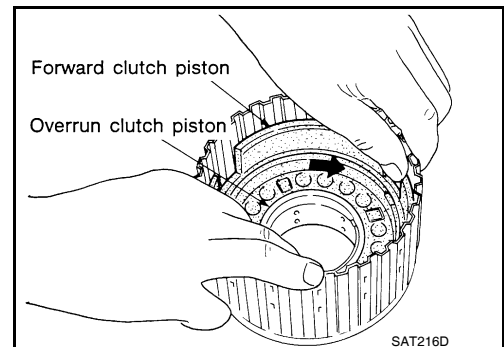

A
B
AT
D
E
F
G
H
I
J
K
L
M
N
O
P

REPAIR FOR COMPONENT PARTS

< SERVICE INFORMATION >

4. Align notch in forward clutch piston with groove in forward clutch drum.

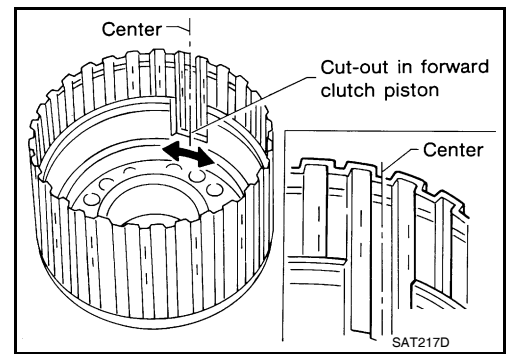

5. Install spring retainer assembly (1) on overrun clutch piston (2).

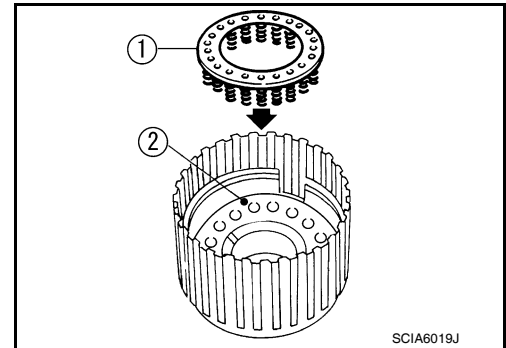

6. Set Tool (A) on spring retainer assembly, and install snap ring (1) while compressing spring retainer assembly.

Tool number : KV31103200 (J-39186)

CAUTION:

- Set SST directly over return springs.
- Do not expand snap ring excessively.

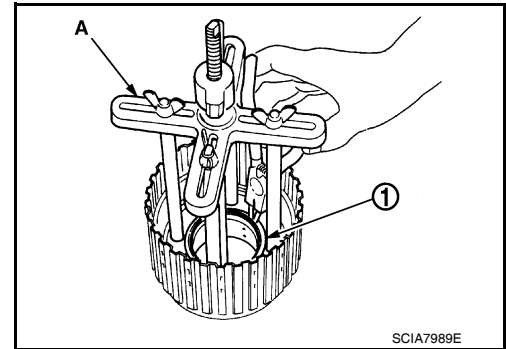

- Do not align snap ring gap with spring retainer assembly stopper.

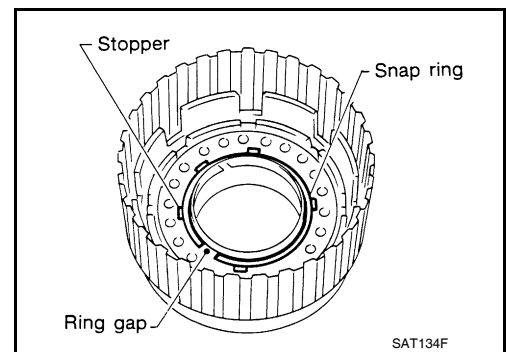

7. Install dish plate, driven plates, drive plates and retaining plate for overrun clutch.

- (1): Snap ring
- (2): Retaining plate
- (3): Drive plate
- (4): Driven plate
- (5): Dish plate

Drive plate/Driven plate: 3/4

CAUTION:

Be careful with the order of plates.

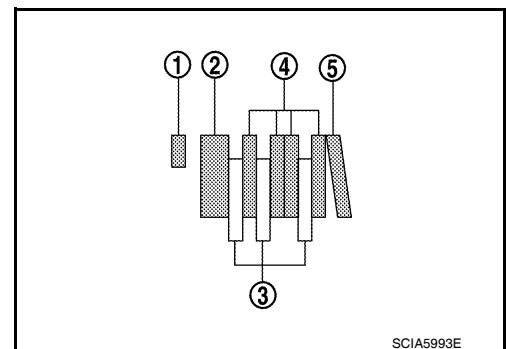

REPAIR FOR COMPONENT PARTS

< SERVICE INFORMATION >

8. Install snap ring for overrun clutch using a flat-bladed screwdriver.

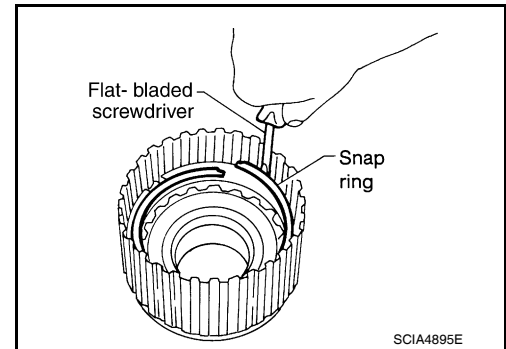

9. Measure clearance between overrun clutch retaining plate and snap ring using feeler gauge. If not within allowable limit, select proper retaining plate. Refer to "Parts Information" for retaining plate selection.

Specified clearance

Standard and allowable limit:

Refer to [AT-376, "Clutches and Brakes"](#).

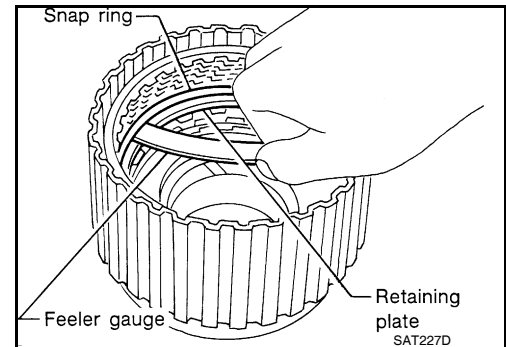

10. Install dish plate, driven plates, drive plates and retaining plate for forward clutch.

- (1): Snap ring
- (2): Retaining plate
- (3): Drive plate
- (4): Driven plate
- (5): Dish plate

Drive plate/Driven plate: 5/5

CAUTION:

Be careful with the order of plates.

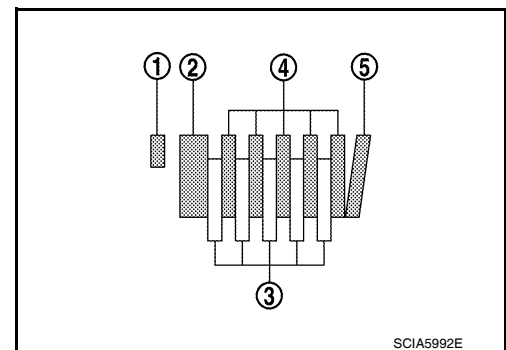

11. Install snap ring for forward clutch using a flat-bladed screwdriver.

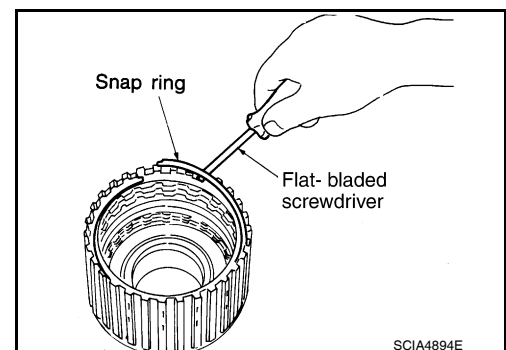

12. Measure clearance between forward clutch retaining plate and snap ring using feeler gauge. If not within allowable limit, select proper retaining plate. Refer to "Parts Information" for retaining plate selection.

Specified clearance

Standard and allowable limit:

Refer to [AT-376, "Clutches and Brakes"](#).

13. Check operation of forward clutch and overrun clutch. Refer to "DISASSEMBLY".

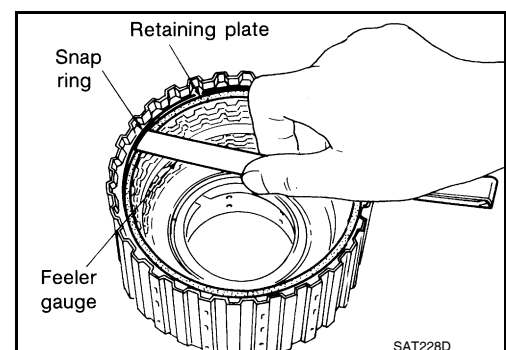

REPAIR FOR COMPONENT PARTS

< SERVICE INFORMATION >

Low & Reverse Brake

INFOID:000000005928298

COMPONENTS

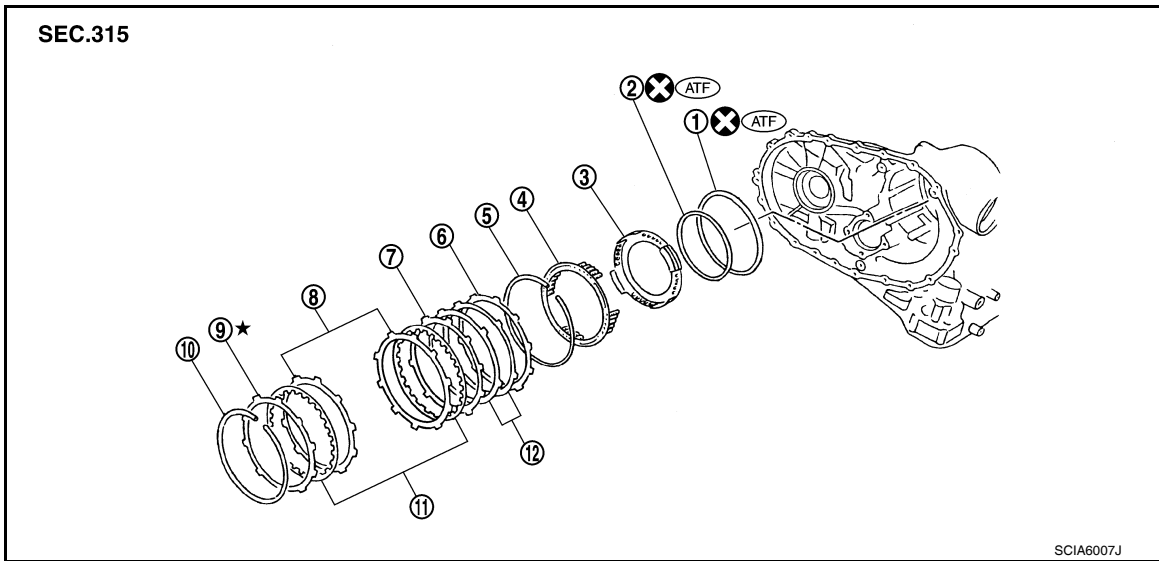

- | | | |
|-----------------------------|-----------------|-------------------------------|
| 1. Seal lip | 2. D-ring | 3. Low & reverse brake piston |
| 4. Spring retainer assembly | 5. Snap ring | 6. Driven plate |
| 7. Retaining plate | 8. Driven plate | 9. Retaining plate |
| 10. Snap ring | 11. Drive plate | 12. Dish plate |

DISASSEMBLY

1. Check operation of low & reverse brake.
 - a. Apply compressed air into oil hole of transaxle case at the location as shown.
 - b. Check to see that retaining plate moves to snap ring.
 - c. If retaining plate does not contact snap ring:
 - D-ring might be damaged.
 - Seal lip might be damaged.
2. Remove snap ring (1) using a suitable tool (A).
3. Remove retaining plates, drive plates, driven plates, dish plates.

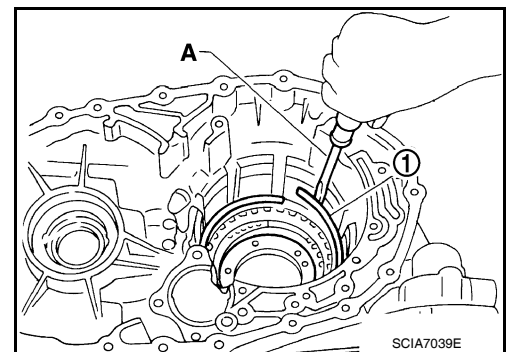
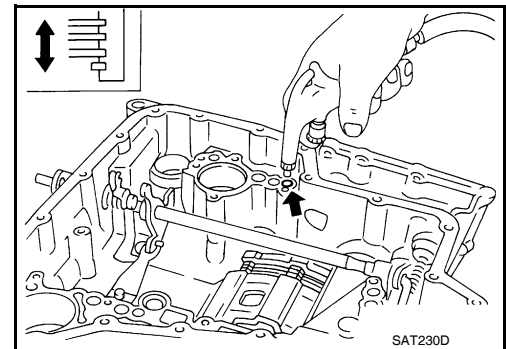

REPAIR FOR COMPONENT PARTS

< SERVICE INFORMATION >

4. Set Tool (A) on spring retainer assembly, and remove snap ring from transaxle case while compressing spring retainer assembly.

Tool number **A: KV31103200 (J-39186)**

CAUTION:

Set Tool directly over return springs.

5. Remove spring retainer assembly from transaxle case.

CAUTION:

Do not remove return springs from spring retainer.

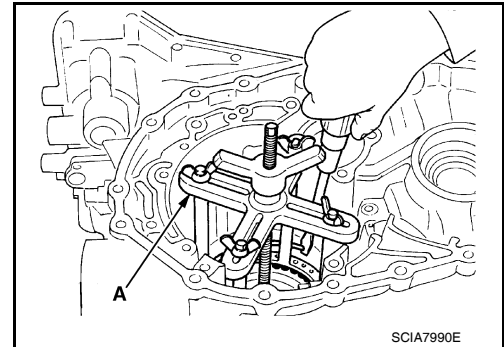

6. Apply compressed air into the oil hole on transaxle case as shown in the figure to raise piston while strongly pressing the whole low & reverse brake piston by hand. When applying compressed air, strongly press the whole piston and adjust the pressure so that it is raised evenly. Portion (A) (low & reverse brake pressure) especially tends to tilt.

CAUTION:

Apply air gradually and allow low & reverse brake piston to come out evenly.

7. Remove low & reverse brake piston from transaxle case by turning it.
8. Inspect transaxle case. Replace if damaged or worn.

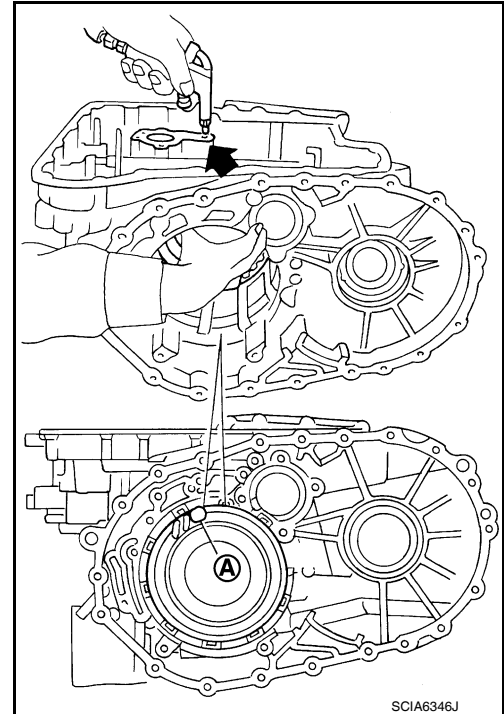

9. Remove seal lip (1) and D-ring (2) from low & reverse brake piston (3).

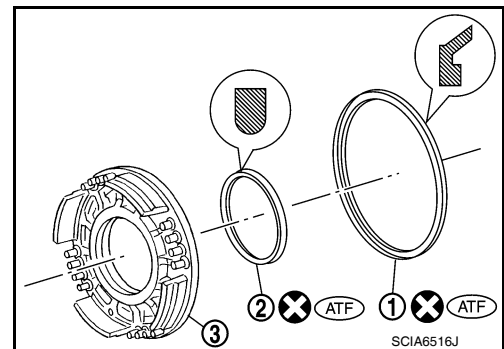

INSPECTION

Low & Reverse Brake Snap Rings

Check for deformation, fatigue or damage. Replace if necessary.

Low & Reverse Brake Drive Plates

A
B
AT
D
E
F
G
H
I
J
K
L
M
N
O
P

REPAIR FOR COMPONENT PARTS

< SERVICE INFORMATION >

- Check facing for burns, cracks or damage. Replace if necessary.
- Measure thickness of facing.

Thickness of drive plate

Standard and allowable limit:

Refer to [AT-376, "Clutches and Brakes"](#).

CAUTION:

- Measure the thickness at 3 locations and find the average.
- Inspect all drive plates.
- Replace if the thickness is below the allowable limit.

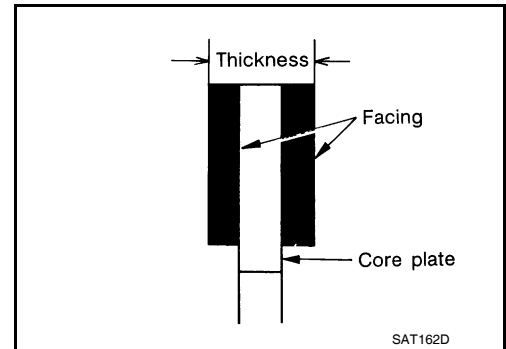

Low & Reverse Brake Dish Plates

- Check for deformation or damage.
- Measure thickness (t) of dish plate. Replace if damaged, deformed or worn.

Thickness of dish plate (t) : 2.93 mm (0.1154 in)

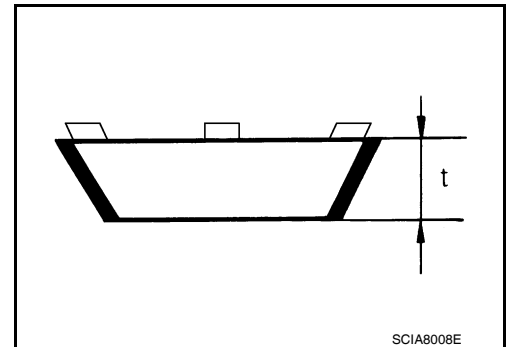

Low & Reverse Brake Spring Retainer Assembly

Check length (L) of spring retainer assembly. Replace if damaged, deformed or worn.

Length (L) : 26.3 mm (1.035 in)

CAUTION:

Do not remove return springs (A) from spring retainer (B)

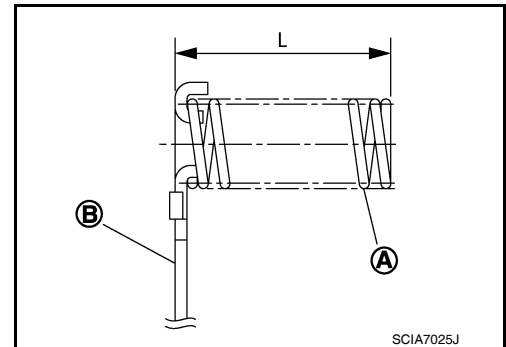

ASSEMBLY

1. Install seal lip (1) and D-ring (2) on low & reverse brake piston (3).

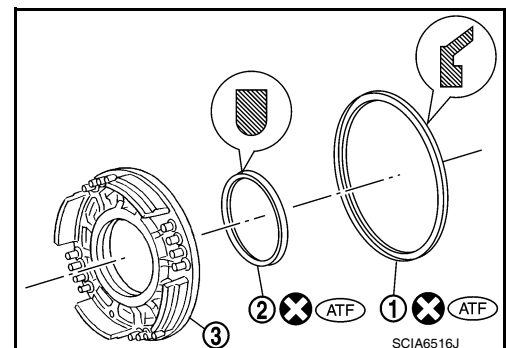

REPAIR FOR COMPONENT PARTS

< SERVICE INFORMATION >

2. Install low & reverse brake piston in transaxle case while turning it.

CAUTION:
Apply ATF to inner surface of transaxle case.

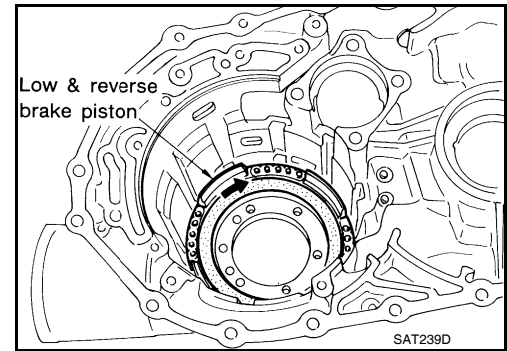

3. Install spring retainer assembly (1) on low & reverse brake piston (2).

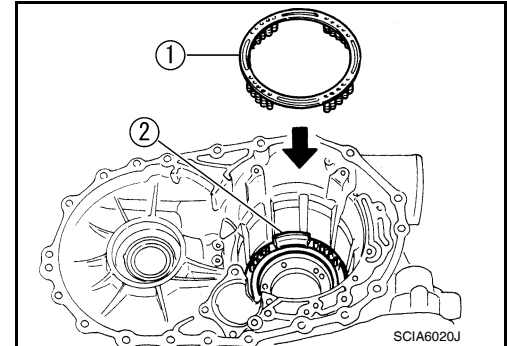

4. Set Tool (A) on spring retainer assembly, and install snap ring while compressing spring retainer assembly.

Tool number **A: KV31103200 (J-39186)**

CAUTION:
Set SST directly over return springs.

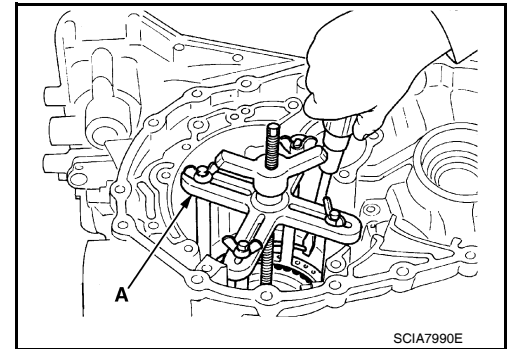

5. Install driven plates, dish plates, retaining plates and drive plates.

• HR16DE engine models

- (1): Snap ring
- (2): Retaining plate
- (3): Drive plate
- (4): Driven plate
- (5): Retaining plate
- (6): Dish plate

Drive plate/Driven plate: 4/4

CAUTION:
Be careful with the order of plates

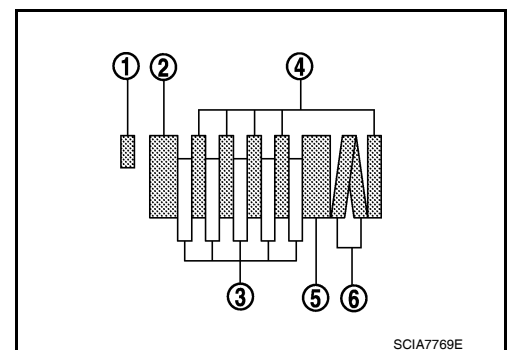
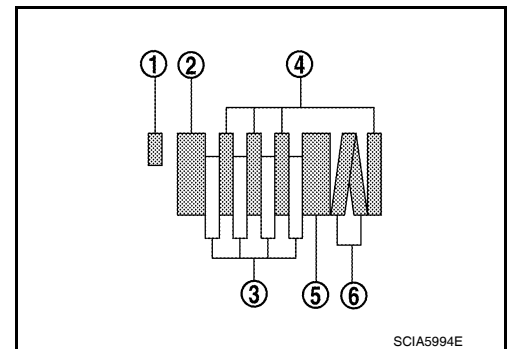

A
B
AT
D
E
F
G
H
I
J
K
L
M
N
O
P

REPAIR FOR COMPONENT PARTS

< SERVICE INFORMATION >

- MR18DE engine models
 - (1): Snap ring
 - (2): Retaining plate
 - (3): Drive plate
 - (4): Driven plate
 - (5): Retaining plate
 - (6): Dish plate
- Drive plate/Driven plate: 5/5

CAUTION:

Be careful with the order of plates

NOTE:

Install two dish plates fitting each installation direction with groove displaced slightly.

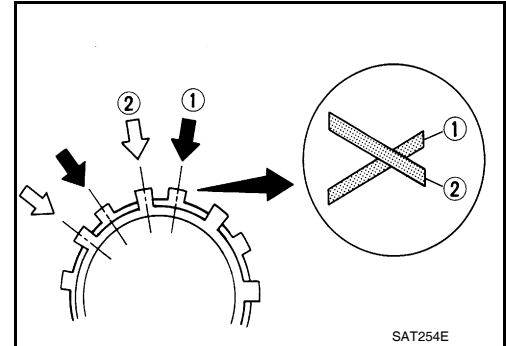

6. Install snap ring (1) using a suitable tool (A).

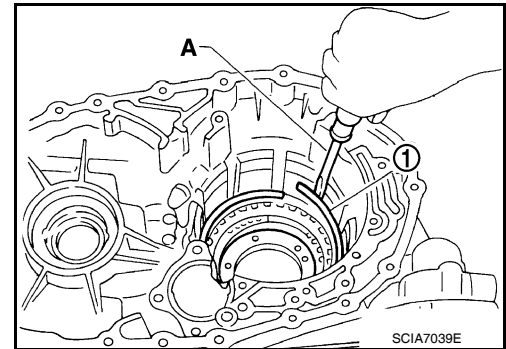

7. Measure clearance between retaining plate and snap ring. If not within allowable limit, select proper retaining plate (front side). Refer to "Parts Information" for retaining plate selection.

Specified clearance

Standard and allowable limit:

Refer to [AT-376, "Clutches and Brakes"](#).

8. Check operation of low & reverse brake. Refer to "DISASSEMBLY".

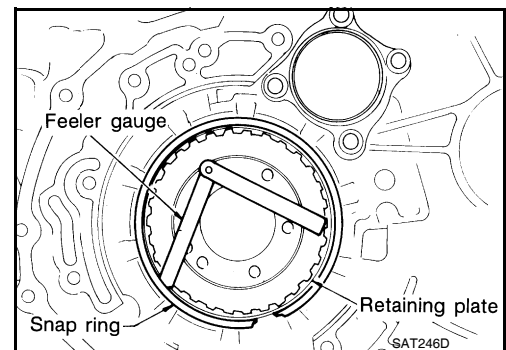

INFOID:000000005928299

Rear Internal Gear and Forward Clutch Hub

COMPONENTS

REPAIR FOR COMPONENT PARTS

< SERVICE INFORMATION >

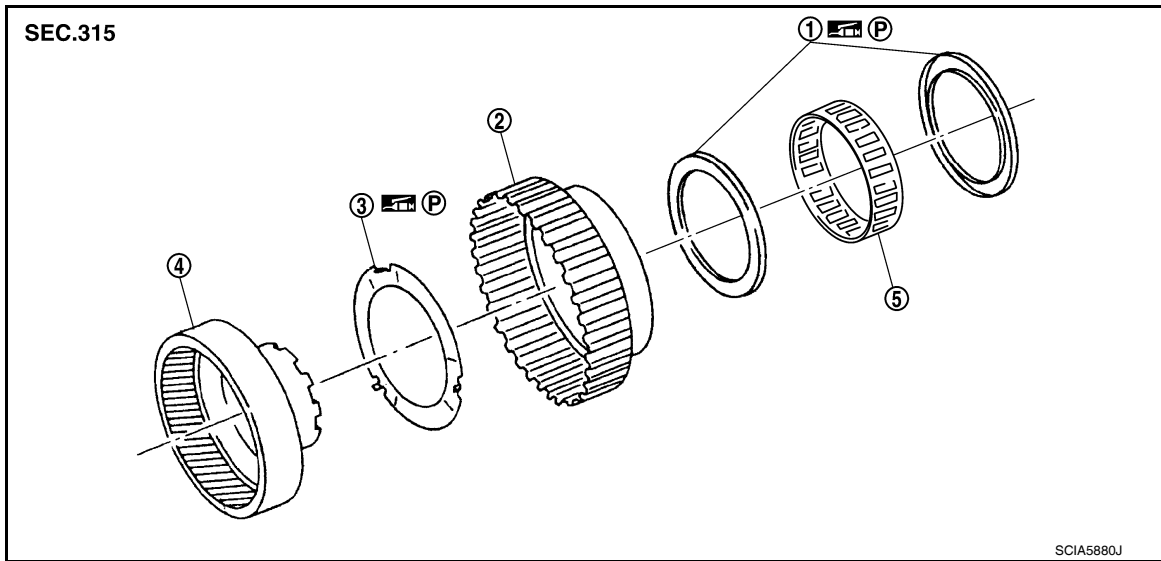

- | | | |
|-----------------------|---------------------------|------------------|
| 1. End bearing | 2. Forward clutch hub | 3. Thrust washer |
| 4. Rear internal gear | 5. Forward one-way clutch | |

DISASSEMBLY

1. Remove forward clutch hub from rear internal gear.

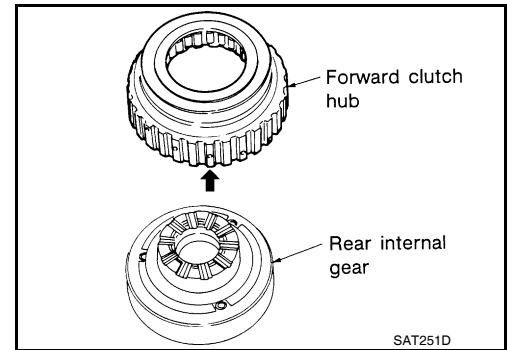

2. Remove end bearing (1) from rear internal gear (2).

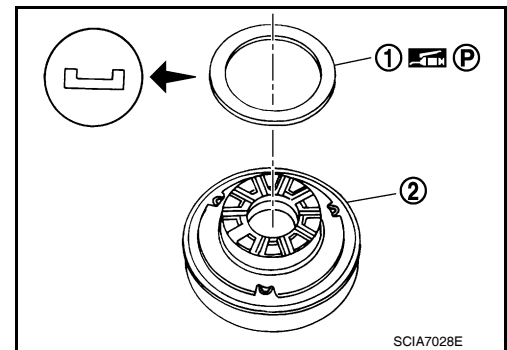

3. Remove thrust washer from rear internal gear.

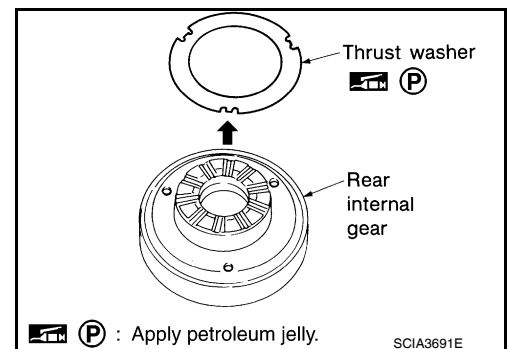

A
B
AT
D
E
F
G
H
I
J
K
L
M
N
O
P

REPAIR FOR COMPONENT PARTS

< SERVICE INFORMATION >

4. Remove end bearing (2) from forward one-way clutch (3).
(1): Forward clutch hub

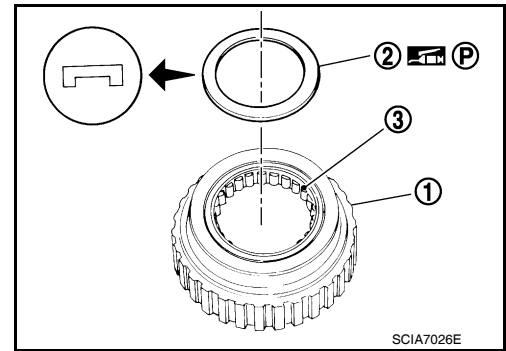

5. Remove forward one-way clutch from forward clutch hub.

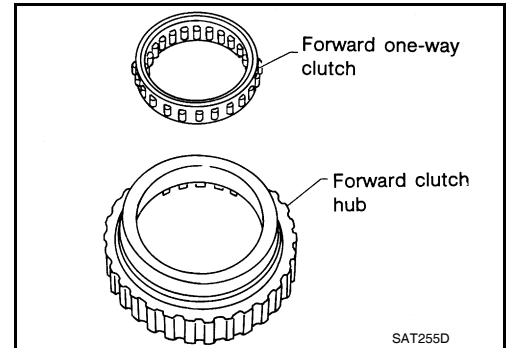

INSPECTION

Rear Internal Gear and Forward Clutch Hub

Check rubbing surfaces for wear or damage. Replace if necessary.

- (1): Rear internal gear
(2): Forward clutch hub

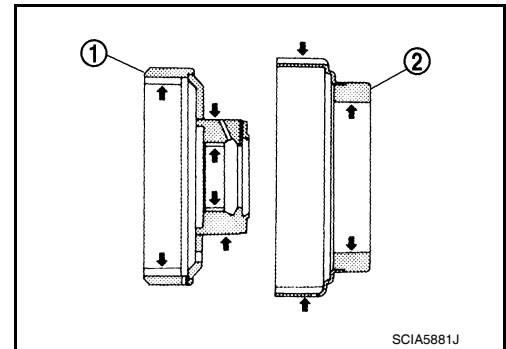

End Bearings and Forward One-way Clutch

- Check end bearings (1) for deformation and damage. Replace if necessary.
- Check forward one-way clutch (2) for wear and damage. Replace if necessary.

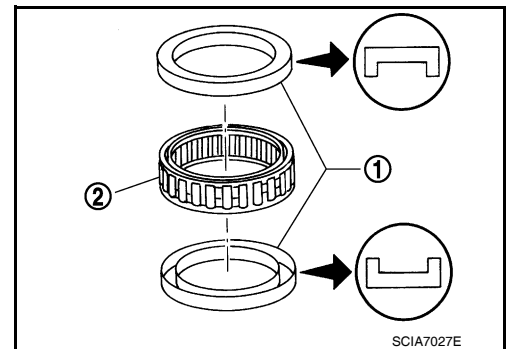

ASSEMBLY

REPAIR FOR COMPONENT PARTS

< SERVICE INFORMATION >

1. Install forward one-way clutch on forward clutch hub.
CAUTION:
Be careful with the direction of forward one-way clutch.

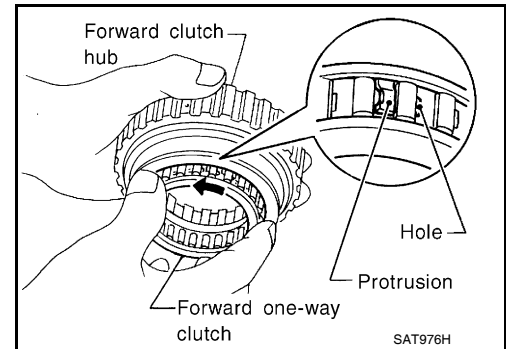

2. Install end bearing (2) on forward one-way clutch (3).
 (1): Forward clutch hub

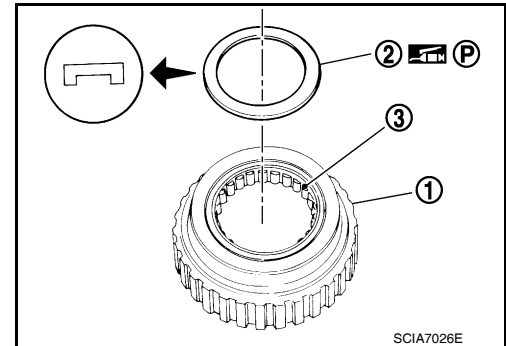

3. Install thrust washer on rear internal gear.
CAUTION:
Align pawls of thrust washer with holes of rear internal gear.

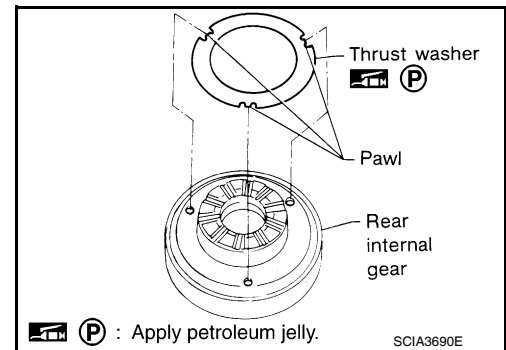

4. Install end bearing (1) on rear internal gear (2).

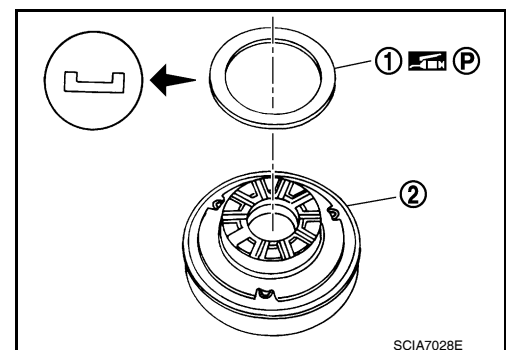

5. Install forward clutch hub on rear internal gear.
CAUTION:
 - Check operation of forward one-way clutch. Hold rear internal gear and turn forward clutch hub. Check forward clutch hub for correct locking and unlocking directions.
 - If not as shown, check the installation direction of forward one-way clutch.

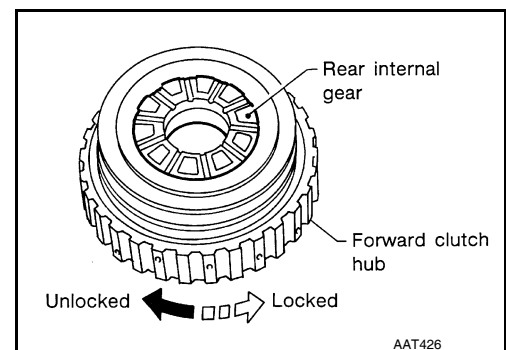

A
B
AT
D
E
F
G
H
I
J
K
L
M
N
O
P

REPAIR FOR COMPONENT PARTS

< SERVICE INFORMATION >

Output Shaft, Output Gear, Idler Gear, Reduction Pinion Gear and Bearing Retainer

INFOID:000000005928300

COMPONENTS

HR16DE engine models

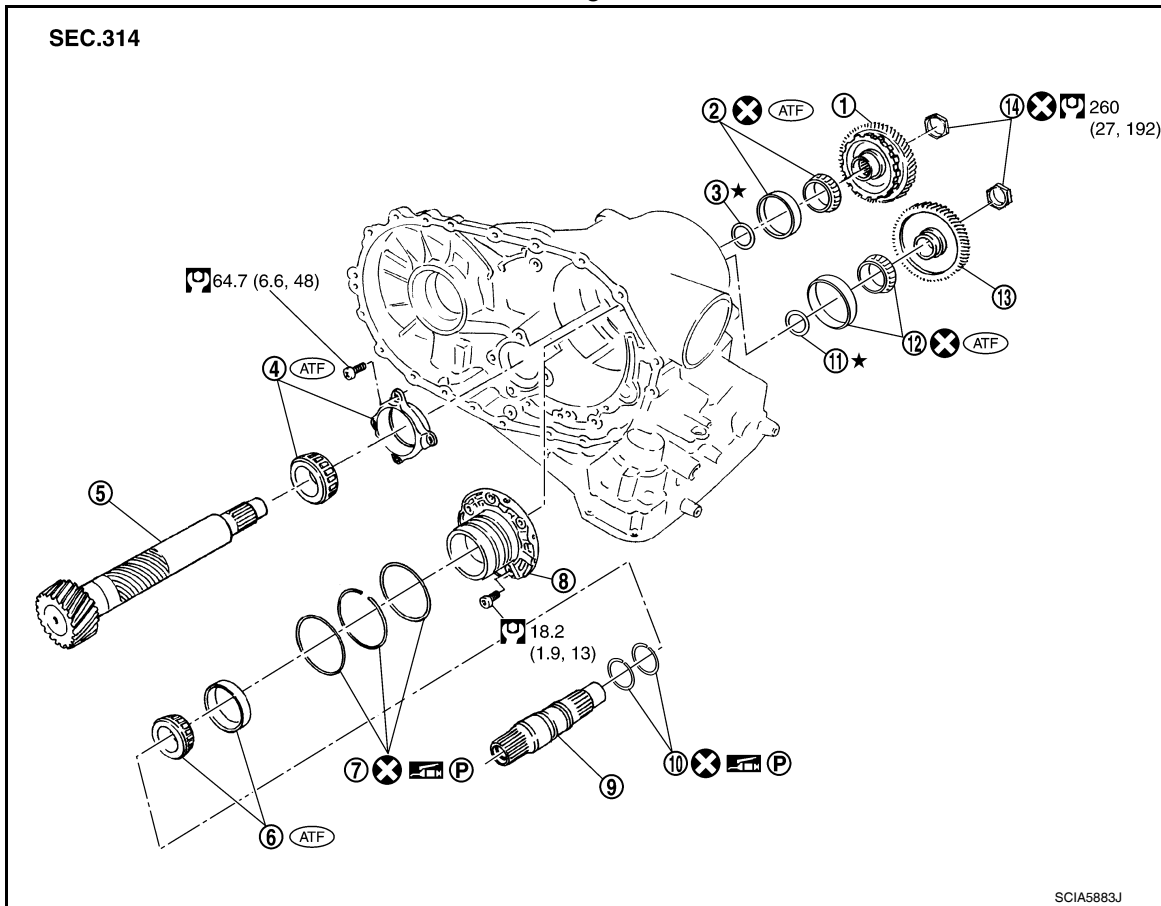

- | | | |
|----------------------------------|----------------------------------|---|
| 1. Idler gear | 2. Idler gear bearing | 3. Reduction pinion gear adjusting shim |
| 4. Reduction pinion gear bearing | 5. Reduction pinion gear | 6. Output shaft bearing |
| 7. Seal ring | 8. Bearing retainer | 9. Output shaft |
| 10. Seal ring | 11. Output gear adjusting spacer | 12. Output gear bearing |
| 13. Output gear | 14. Lock nut | |

REPAIR FOR COMPONENT PARTS

< SERVICE INFORMATION >

MR18DE engine models

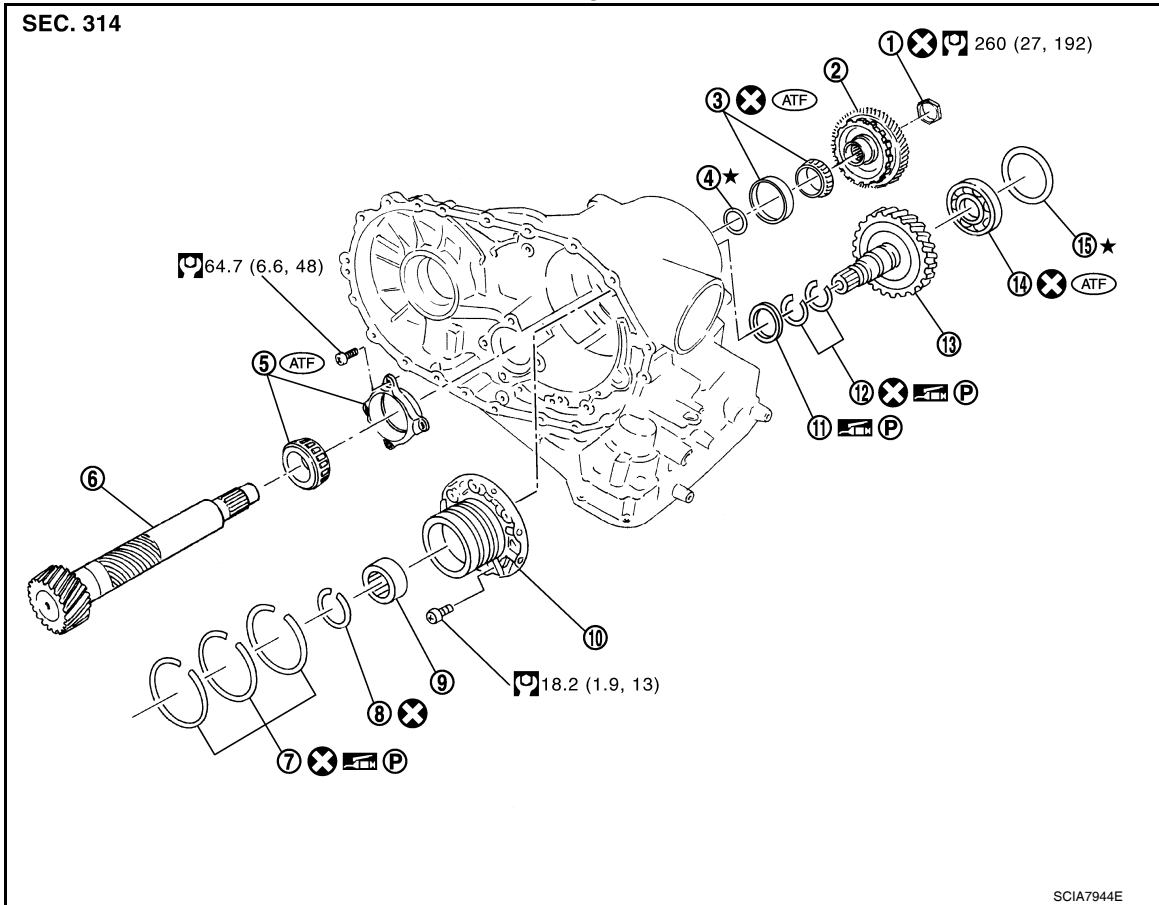

- | | | |
|---|----------------------------------|---------------------------------|
| 1. Lock nut | 2. Idler gear | 3. Idler gear bearing |
| 4. Reduction pinion gear adjusting shim | 5. Reduction pinion gear bearing | 6. Reduction pinion gear |
| 7. Seal ring | 8. Snap ring | 9. Radial needle bearing |
| 10. Bearing retainer | 11. Thrust needle bearing | 12. Seal ring |
| 13. Output shaft | 14. Output shaft bearing | 15. Output shaft adjusting shim |

DISASSEMBLY

- Remove seal rings (1) from output shaft (2) and bearing retainer (3).
 - HR16DE engine models

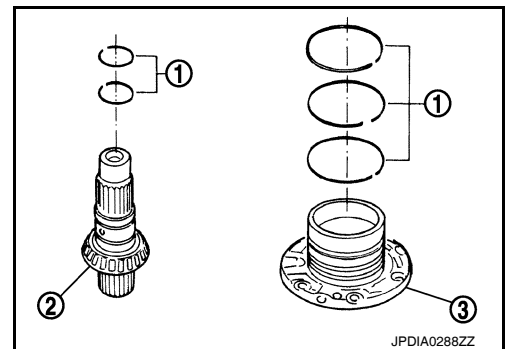

A
B
AT
D
E
F
G
H
I
J
K
L
M
N
O
P

REPAIR FOR COMPONENT PARTS

< SERVICE INFORMATION >

- MR18DE engine models

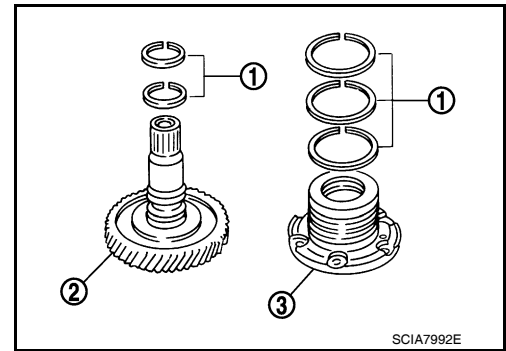

2. Remove output shaft bearing according to the following procedures.

a. HR16DE engine models

- i. Set output shaft bearing inner race (1) on suitable tool (A) and set suitable tool (B) on output shaft (2), and press output shaft to remove output shaft bearing inner race.

CAUTION:

- Set a suitable tool (A) on output shaft bearing inner race.

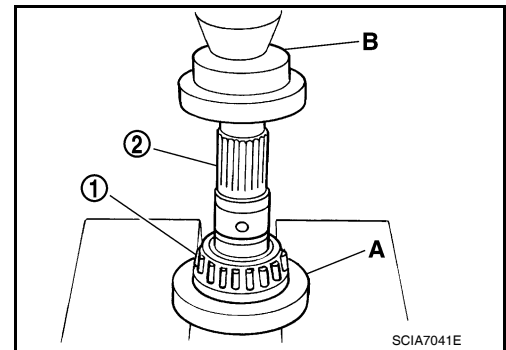

- ii. Set Tool (A) on output shaft bearing outer race, and remove output shaft bearing outer race from bearing retainer (1).

Tool number A: KV381054S0 (J-34286)

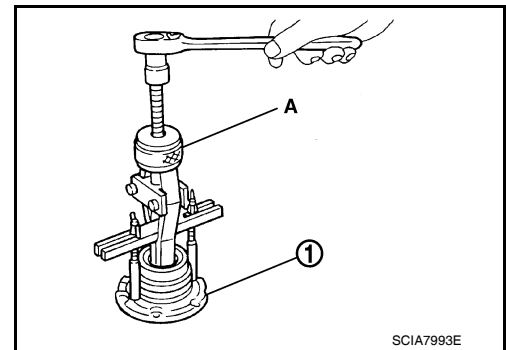

b. MR18DE engine models

- i. Remove output shaft bearing from output shaft with suitable tools.

CAUTION:

- Always replace bearing with a new one when removed
- Do not damage output shaft.

3. Remove output gear bearing (HR16DE engine models) or radial bearing (MR18DE engine models) according to the following procedures.

a. HR16DE engine models

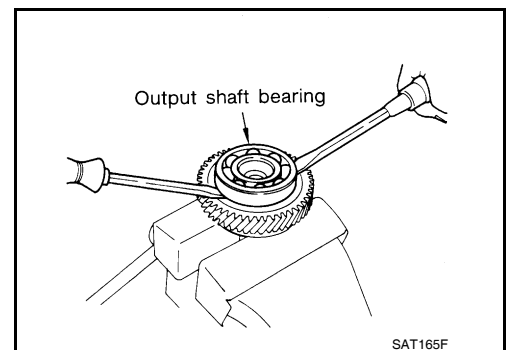

REPAIR FOR COMPONENT PARTS

< SERVICE INFORMATION >

- i. Insert suitable tool (A) between the mating surfaces of output gear (1) and output gear bearing inner race (2), and enlarge the gap.

CAUTION:

Be careful not to damage output gear (1).

- ii. Set suitable tool (B) on output gear (1), and remove output gear bearing inner race (2) with a suitable tool (C) as shown.

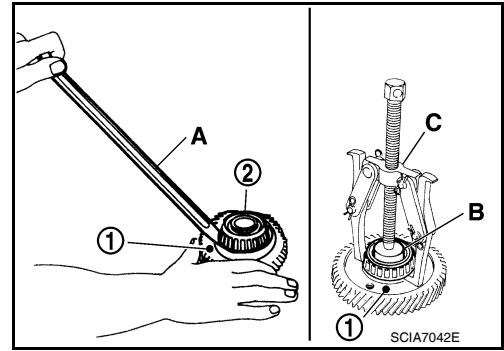

- iii. Set Tool (A) on output gear bearing outer race (1), and remove output gear bearing outer race from bearing retainer (2).

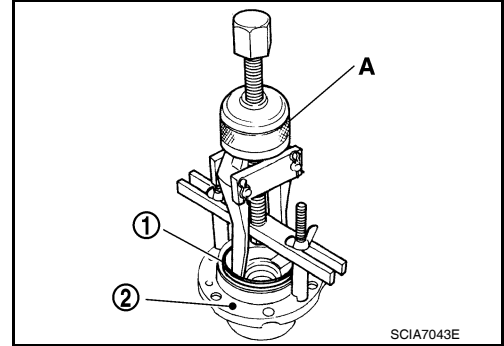

- b. MR18DE engine models

- i. Remove snap ring (1) using suitable tool from bearing retainer (2).

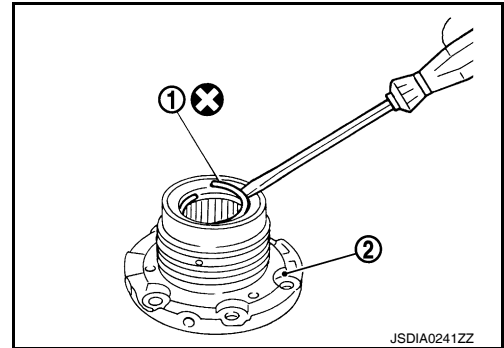

- ii. Remove radial needle bearing from bearing retainer (1) using Tool (A).

Tool number

A: KV381054S0 (J-34286)

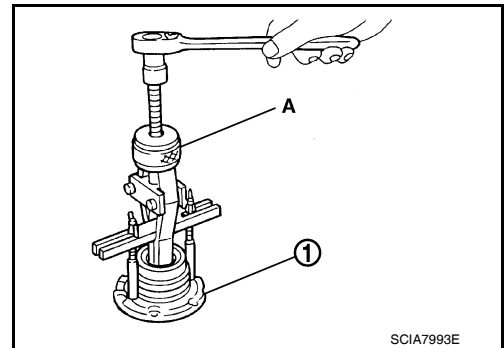

A
B
AT
D
E
F
G
H
I
J
K
L
M
N
O
P

REPAIR FOR COMPONENT PARTS

< SERVICE INFORMATION >

4. Insert a suitable tool (A) between the mating surfaces of idler gear (1) and idler gear bearing inner race (2), and enlarge the gap.

CAUTION:

Be careful not to damage idler gear (1).

5. Set suitable tool (B) on idler gear (1), and remove idler gear bearing inner race (2) with a suitable tool (C) as shown.

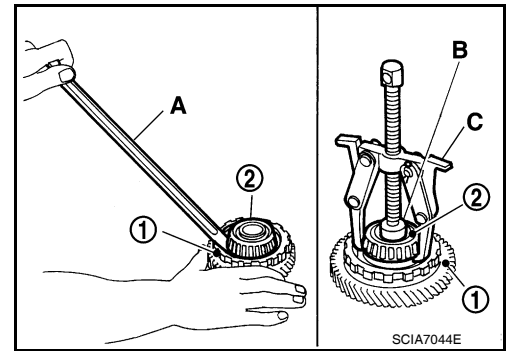

6. Remove idler gear bearing outer race from transaxle case using Tool.

Tool number : KV381054S0 (J-34286)

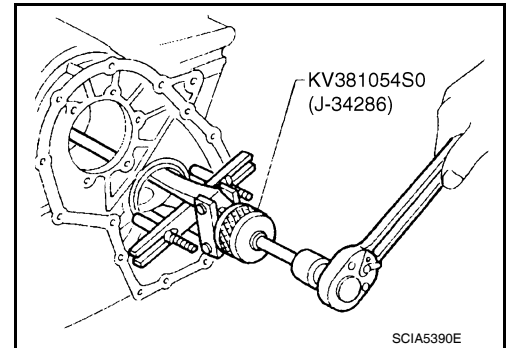

7. Set Tool (A) to reduction pinion gear bearing inner race, press out reduction pinion gear bearing inner race from reduction pinion gear.

Tool number A: ST30031000 (J-22912-01)

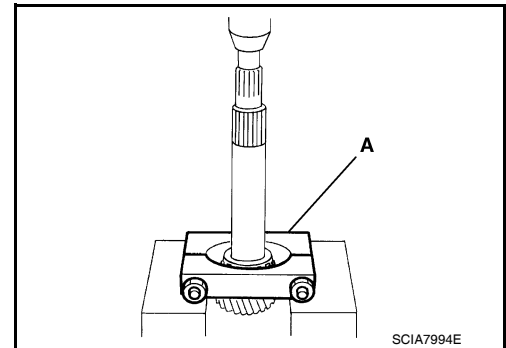

8. Remove reduction pinion gear bearing outer race from transaxle case.

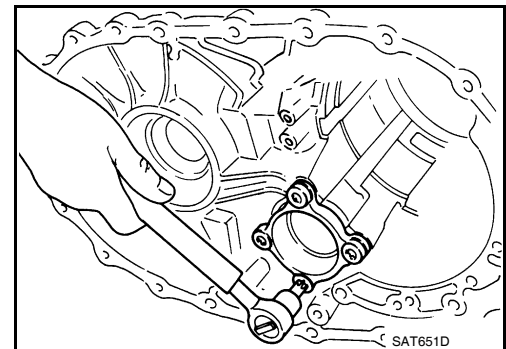

INSPECTION

Output Shaft, Idler Gear and Reduction Pinion Gear
Check for wear, damage or crack. Replace if necessary.

Bearings

REPAIR FOR COMPONENT PARTS

< SERVICE INFORMATION >

- Make sure bearings roll freely and are free from noise, cracks, pitting or wear. Replace if necessary.

CAUTION:

When replacing taper roller bearing, replace outer and inner race as a set.

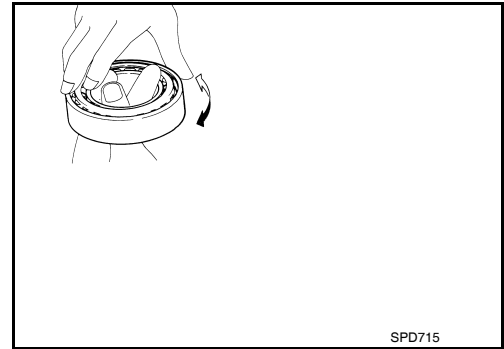

Seal Ring Clearance

- Install new seal rings (1) to output shaft (2) and bearing retainer (3).
- HR16DE engine models

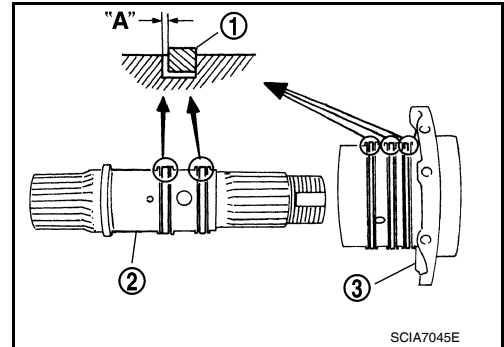

- MR18DE engine models

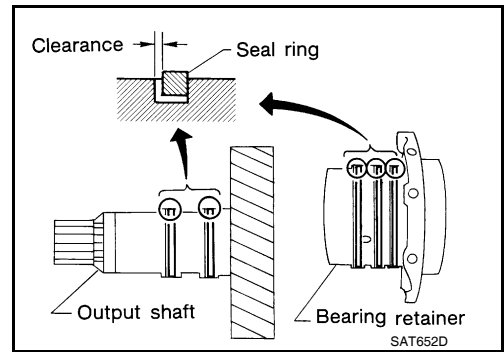

- Measure clearance (A) between each seal ring and ring groove of output shaft. If not within allowable limit, replace output shaft.

Standard clearance and allowable limit:

Refer to [AT-379, "Output Shaft"](#).

- Measure clearance (A) between seal ring and ring groove of bearing retainer. If not within allowable limit, replace bearing retainer.

Standard clearance and allowable limit:

Refer to [AT-379, "Bearing Retainer"](#).

ASSEMBLY

A
B
AT
D
E
F
G
H
I
J
K
L
M
N
O
P

REPAIR FOR COMPONENT PARTS

< SERVICE INFORMATION >

1. Set Tool (A) on reduction pinion gear bearing inner race, and press reduction pinion gear to reduction pinion gear bearing inner race.

Tool number : ST35272000 (J-26092)

CAUTION:

Apply ATF to reduction pinion gear bearing inner race.

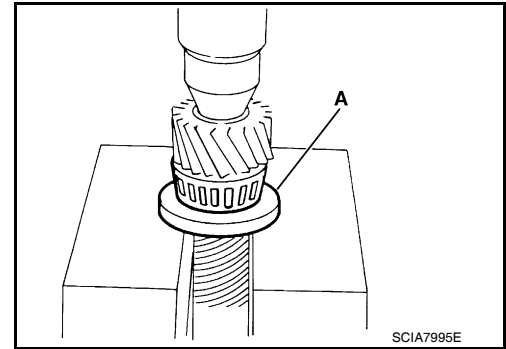

2. Install reduction pinion gear bearing outer race on transaxle case. Refer to "COMPONENTS".

• Check reduction pinion gear bearing preload. Refer to [AT-349, "Adjustment \(1\) \(For MR18DE Engine Models\)"](#)

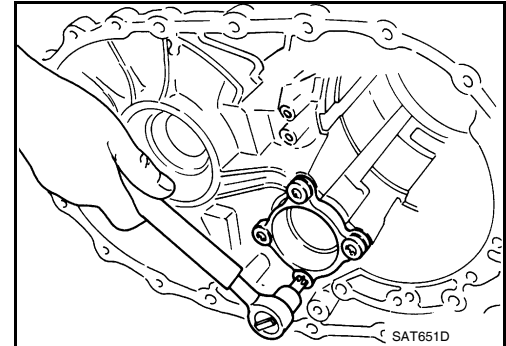

3. Set Tool (A) and a suitable tool (B) on idler gear bearing inner race (1), and press idler gear bearing inner race (1) to idler gear (2).

Tool number : ST35272000 (J-26092)

CAUTION:

- Do not reuse idler gear bearing.
- Apply ATF to idler gear bearing.

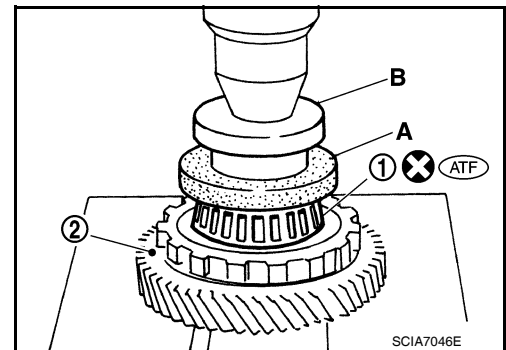

4. Set Tool (A) on idler gear bearing outer race, and drive idler gear bearing outer race into transaxle case.

Tool number : ST37830000 (—)

CAUTION:

- Do not reuse idler gear bearing.
- Apply ATF to idler gear bearing.

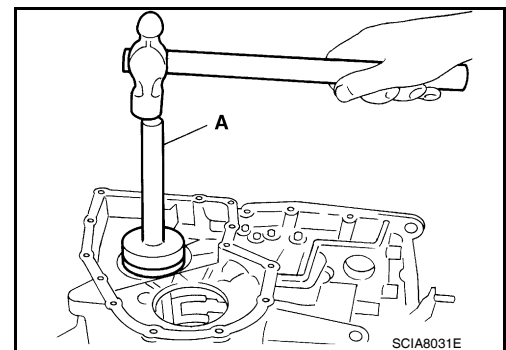

5. Install output shaft bearing according to the following procedures.
 - a. HR16DE engine models

REPAIR FOR COMPONENT PARTS

< SERVICE INFORMATION >

- i. Set a suitable tool (A) and (B) on output shaft bearing (1), and press output shaft (2) to output shaft bearing inner race.

CAUTION:

- Set suitable tool on output shaft bearing inner race.

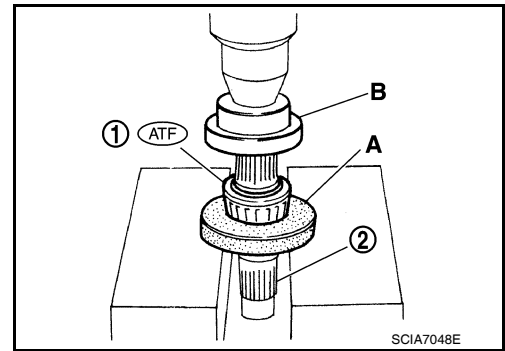

- ii. Set suitable tool (A) on output shaft bearing outer race, and drive output shaft bearing outer race to bearing retainer.

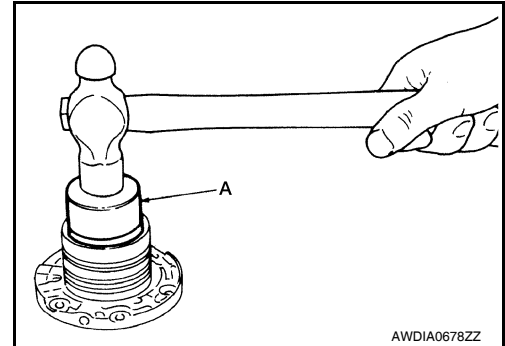

- b. MR18DE engine models

- i. Set Tool on output shaft bearing, and press output shaft bearing to output shaft.

Tool number : ST35321000 (—)

CAUTION:

- Set Tool on output shaft bearing inner race.
- Do not reuse output shaft bearing.
- Apply ATF to output shaft bearing.

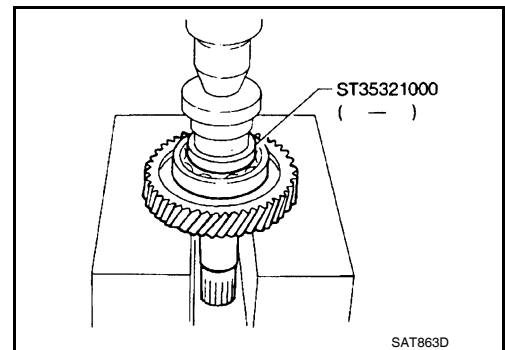

6. Install output gear bearing (HR16DE engine models) or radial needle bearing (MR18DE engine models) according to the following procedures.

- a. HR16DE engine models

- i. Set Tool (A) and suitable tool (B) on output gear bearing (1), and press output gear bearing to output gear (2).

Tool number : ST35272000 (J-26092)

CAUTION:

- Set Tool (A) on output gear bearing inner race.

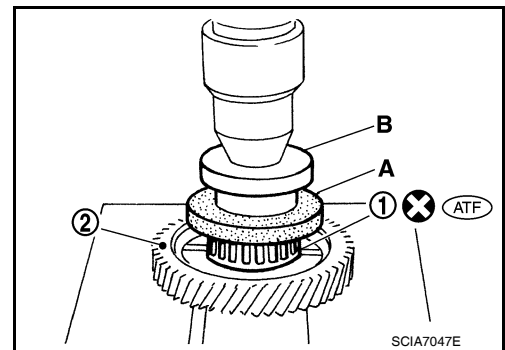

A
B
AT
D
E
F
G
H
I
J
K
L
M
N
O
P

REPAIR FOR COMPONENT PARTS

< SERVICE INFORMATION >

- ii. Set Tool on output gear bearing outer race, and drive output gear bearing outer race to bearing retainer.

Tool number : ST33400001 (J-26082)

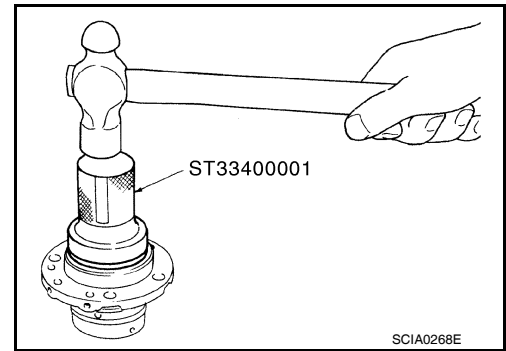

- b. MR18DE engine models

- i. Set drift [commercial service tool] on radial needle bearing, and press radial needle bearing into bearing retainer.

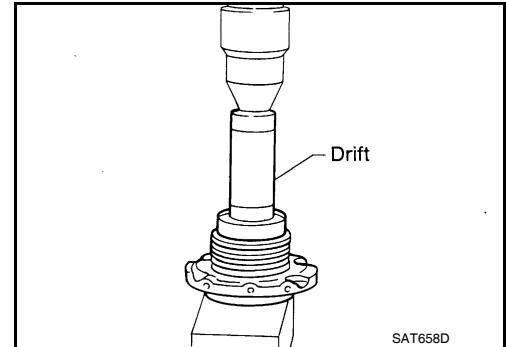

- ii. Install snap ring to bearing retainer using suitable tool.

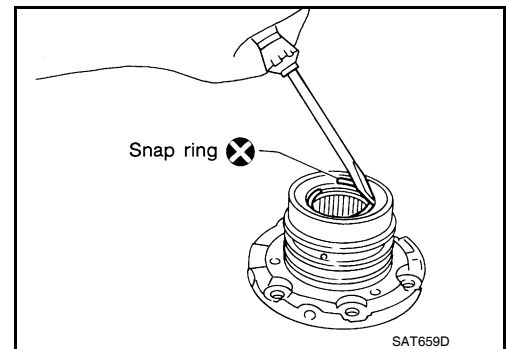

7. After packing ring grooves with petroleum jelly, carefully install new seal rings (1) on output shaft (2) and bearing retainer (3).

- HR16DE engine models

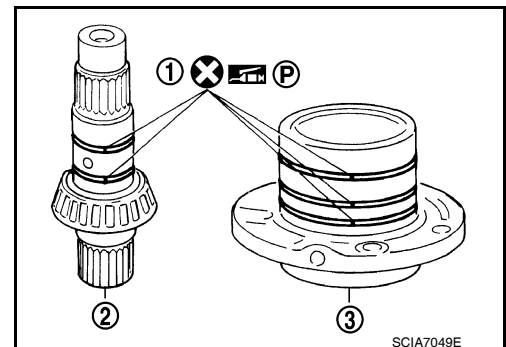

REPAIR FOR COMPONENT PARTS

< SERVICE INFORMATION >

- MR18DE engine models

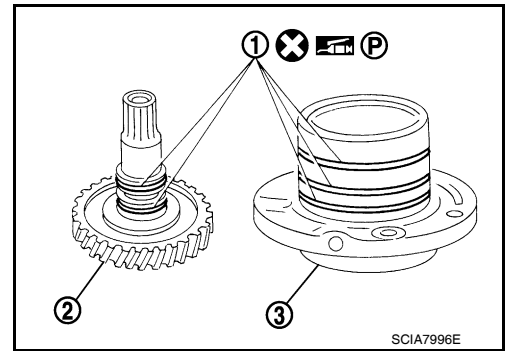

CAUTION:

Roll paper around seal rings to prevent seal rings from spreading.

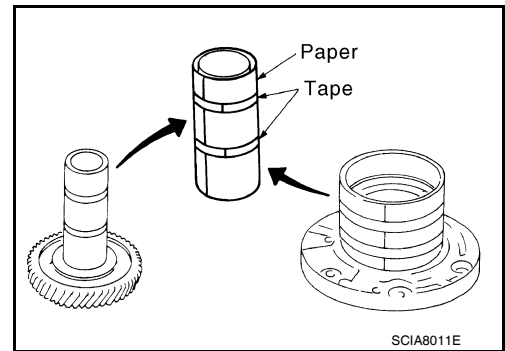

Band Servo Piston Assembly

COMPONENTS

HR16DE engine models

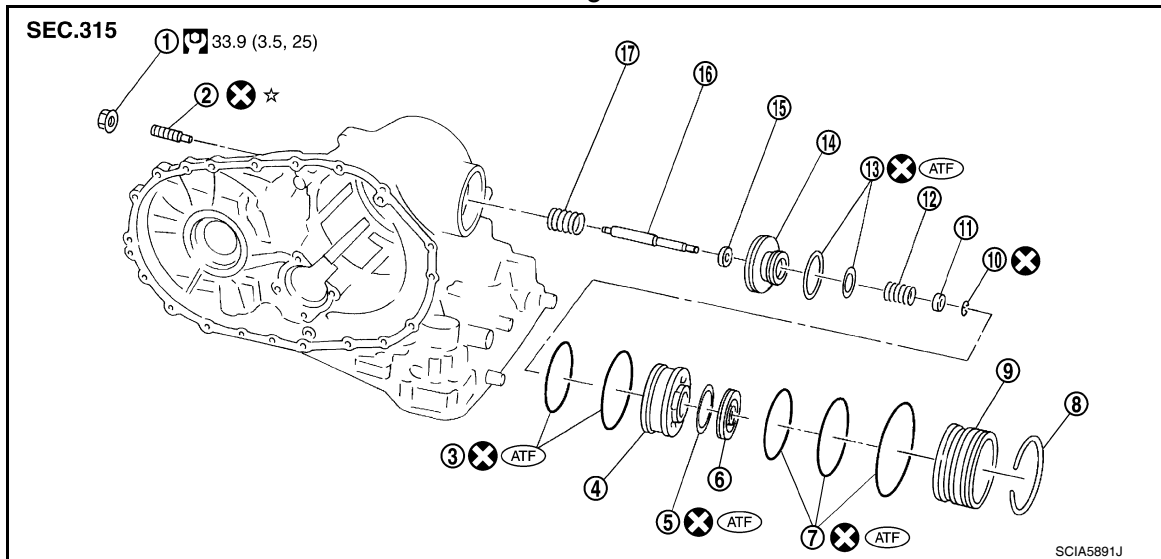

- | | | |
|----------------------------|-----------------------------|------------------------------|
| 1. Lock nut | 2. Anchor end pin | 3. O-ring |
| 4. Servo piston retainer | 5. D-ring | 6. OD servo piston |
| 7. O-ring | 8. Snap ring | 9. OD servo piston retainer |
| 10. E-ring | 11. Spring retainer | 12. OD servo return spring |
| 13. D-ring | 14. Band servo piston | 15. Band servo thrust washer |
| 16. Band servo piston stem | 17. 2nd servo return spring | |

REPAIR FOR COMPONENT PARTS

< SERVICE INFORMATION >

MR18DE engine models

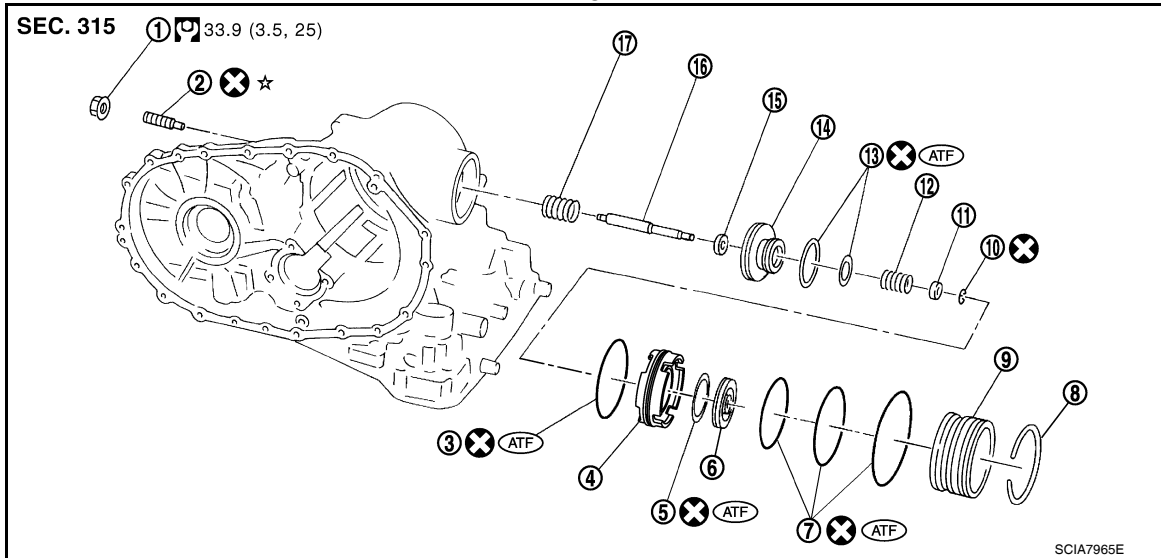

- | | | |
|----------------------------|-----------------------------|------------------------------|
| 1. Lock nut | 2. Anchor end pin | 3. O-ring |
| 4. Servo piston retainer | 5. D-ring | 6. OD servo piston |
| 7. O-ring | 8. Snap ring | 9. OD servo piston retainer |
| 10. E-ring | 11. Spring retainer | 12. OD servo return spring |
| 13. D-ring | 14. Band servo piston | 15. Band servo thrust washer |
| 16. Band servo piston stem | 17. 2nd servo return spring | |

DISASSEMBLY

1. Push in OD servo piston assembly using a suitable tool (A) and a suitable tool (B), and then remove snap ring (1) from transaxle case using a suitable tool (C).

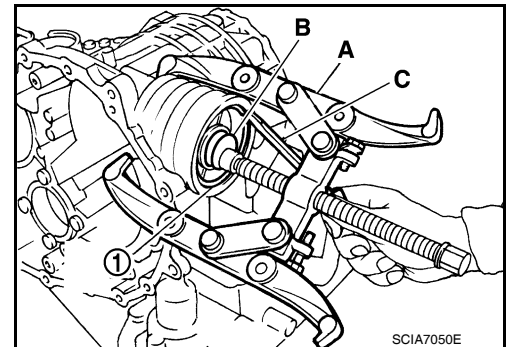

2. Apply compressed air into the oil hole as shown to remove OD servo piston assembly and band servo piston assembly.

CAUTION:

Do not blow air in too quickly, or OD servo piston assembly, band servo piston assembly and ATF could jump out. Carefully blow air little by little while protecting with lint-free cloth (A).

3. Remove 2nd servo return spring from transaxle case.

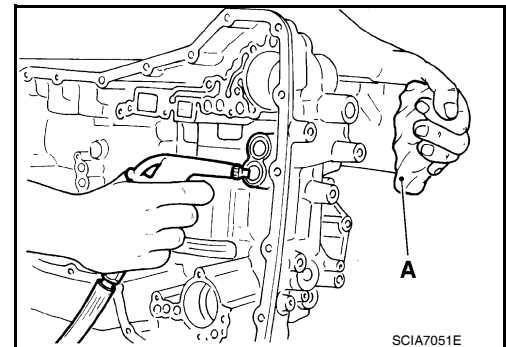

REPAIR FOR COMPONENT PARTS

< SERVICE INFORMATION >

- Wrap OD servo piston retainer (1) using lint-free cloth (A), and then apply compressed air into the band servo piston stem hole on OD servo piston (2) to remove OD servo piston (2) from OD servo piston retainer (1).

CAUTION:

Do not blow air in too quickly, or OD servo piston (2) and ATF could jump out. Carefully blow air little by little while protecting with lint-free cloth (A).

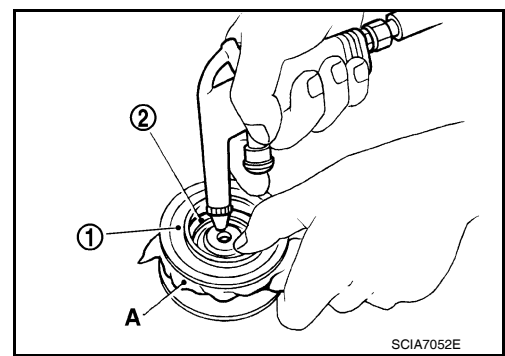

- Remove D-ring (1) from OD servo piston (2).

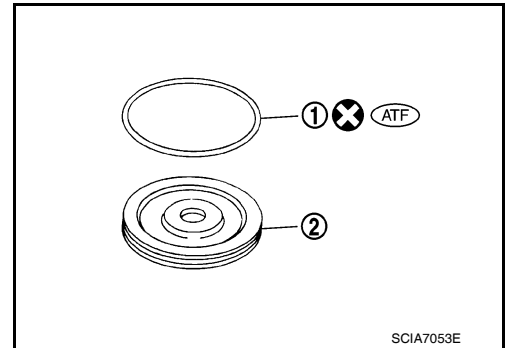

- Remove O-rings from OD servo piston retainer.
 - (1): O-ring (small diameter)
 - (2): O-ring (medium diameter)
 - (3): O-ring (large diameter)
 - (4): OD servo piston retainer

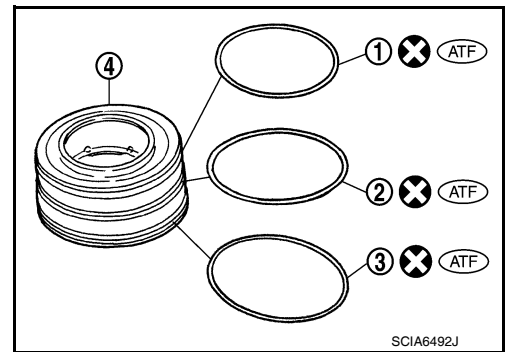

- Remove band servo piston assembly (1) from servo piston retainer (2).

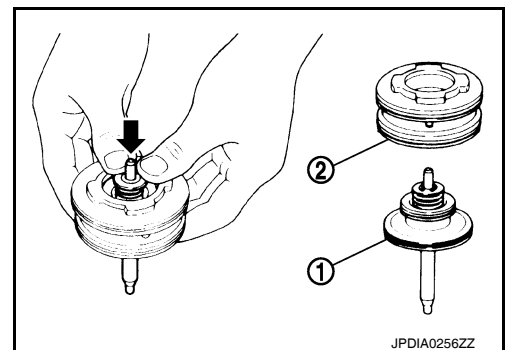

- Place band servo piston stem on a wooden block, and remove E-ring from band servo piston stem using a suitable tool while pressing spring retainer downward.

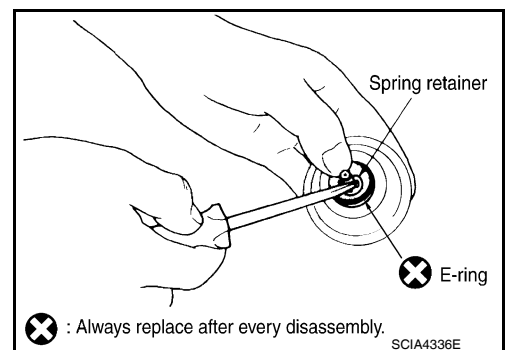

REPAIR FOR COMPONENT PARTS

< SERVICE INFORMATION >

9. Remove spring retainer (1), OD servo return spring (2), band servo piston (3) and band servo thrust washer (4) from band servo piston stem (5).

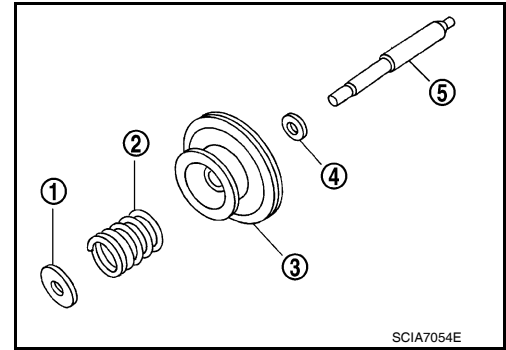

10. Remove O-ring from servo piston retainer.

- a. HR16DE engine models
 (1): O-ring (small diameter)
 (2): O-ring (large diameter)
 (3): Servo piston retainer

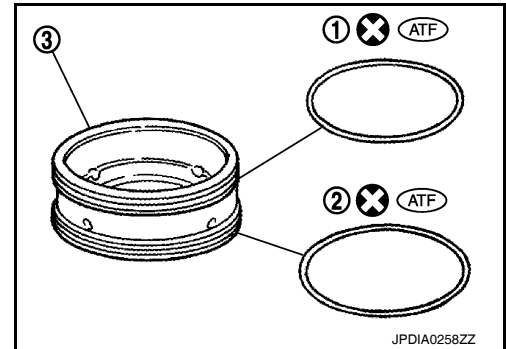

- b. MR18DE engine models
 (1): O-ring
 (2): Servo piston retainer

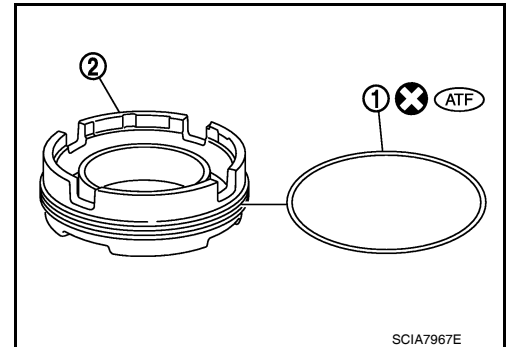

11. Remove D-rings from band servo piston.

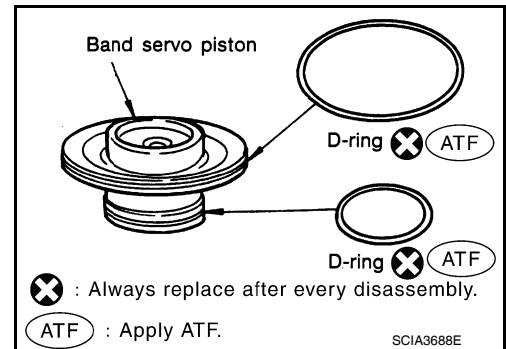

INSPECTION

Pistons, Retainers and Piston Stem

Check the sliding surfaces for damage or excessive wear. Replace if necessary.

Return Springs

REPAIR FOR COMPONENT PARTS

< SERVICE INFORMATION >

- Check each return spring for damage or deformation. Also measure free length. Refer to [AT-378, "Band Servo"](#).
- Replace springs if deformed or fatigued.

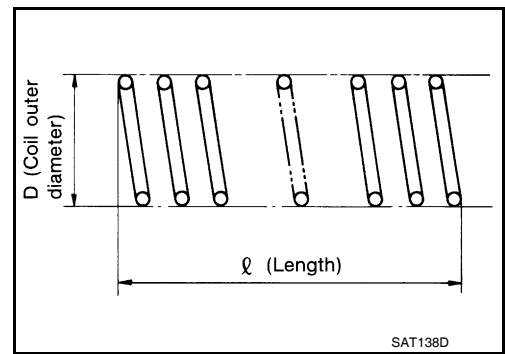

ASSEMBLY

1. Install D-rings to band servo piston.

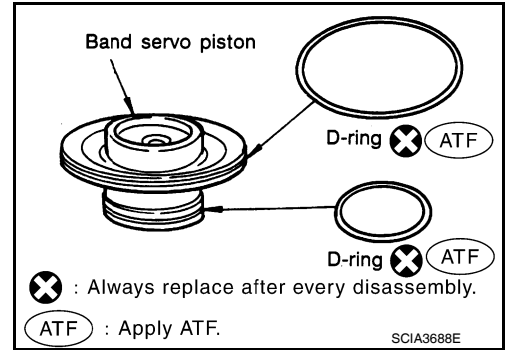

2. Install band servo thrust washer (4), band servo piston (3), OD servo return spring (2) and spring retainer (1) to band servo piston stem (5).

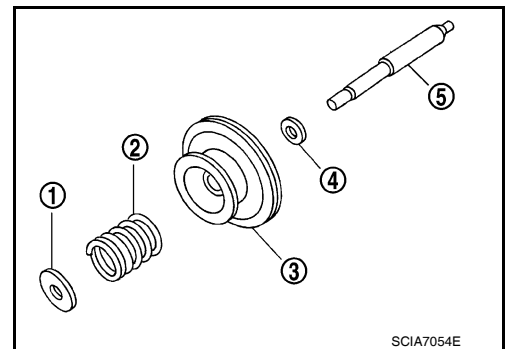

3. Place band servo piston stem (1) on a wooden block, and install E-ring (2) to band servo piston stem (1) while pressing spring retainer (3) downward.

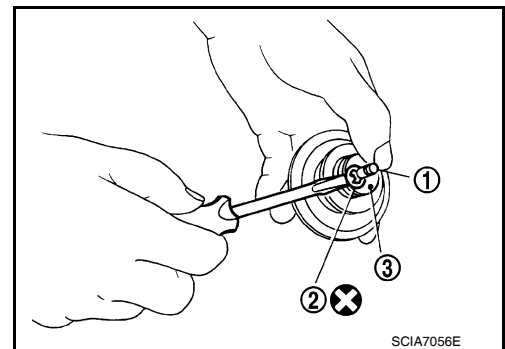

4. Install O-ring to servo piston retainer.

REPAIR FOR COMPONENT PARTS

< SERVICE INFORMATION >

- HR16DE engine models
 (1): O-ring (small diameter)
 (2): O-ring (large diameter)
 (3): Servo piston retainer

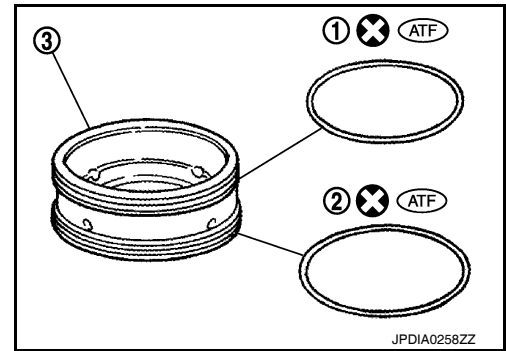

- MR18DE engine models
 (1): O-ring
 (2): Servo piston retainer

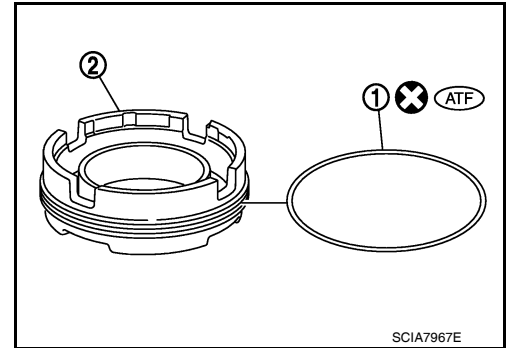

5. Install band servo piston assembly to servo piston retainer by pushing it inward.

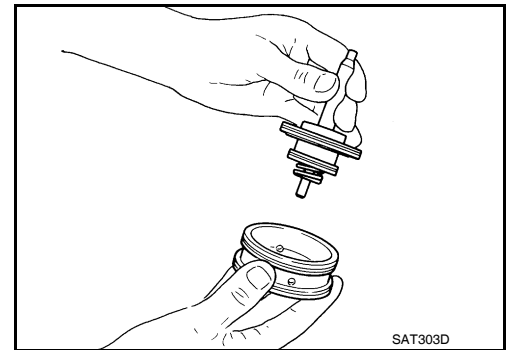

6. Install D-ring (1) to OD servo piston (2).

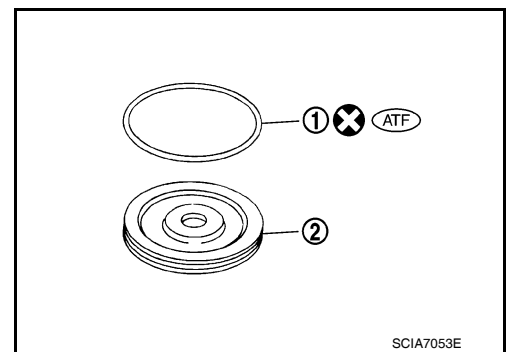

7. Install O-rings and to OD servo piston retainer.
 (1): O-ring (small diameter)
 (2): O-ring (medium diameter)
 (3): O-ring (large diameter)
 (4): OD servo piston retainer

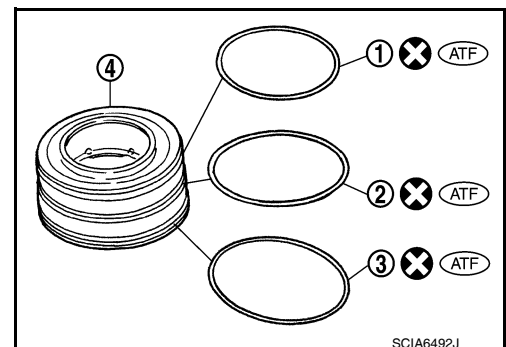

REPAIR FOR COMPONENT PARTS

< SERVICE INFORMATION >

8. Install OD servo piston (1) to OD servo piston retainer (2) in the direction shown.

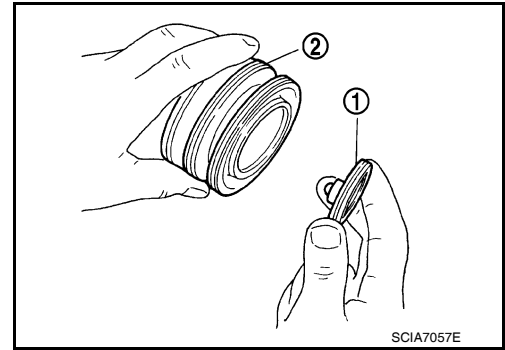

9. Install 2nd servo return spring (2) and band servo piston assembly (3) to transaxle case (1).

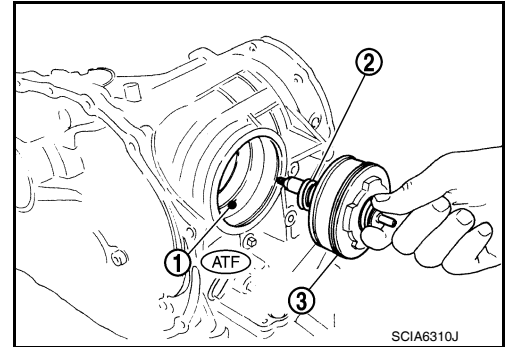

10. Install OD servo piston assembly (2) to transaxle case (1).

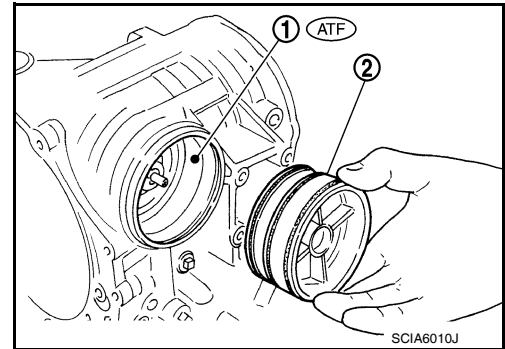

11. Push in OD servo piston assembly using a suitable tool (A) and a suitable tool (B), and install snap ring (1) to transaxle case using a suitable tool (C).

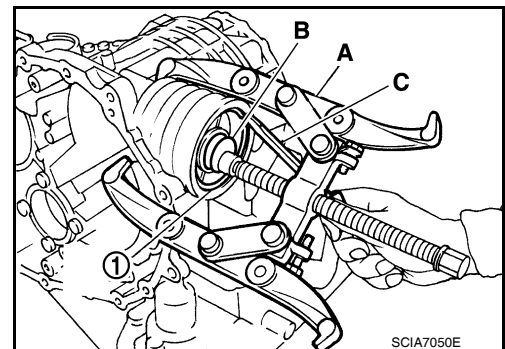

Final Drive

COMPONENTS

INFOID:000000005928302

A
B
AT
D
E
F
G
H
I
J
K
L
M
N
O
P

REPAIR FOR COMPONENT PARTS

< SERVICE INFORMATION >

HR16DE engine models

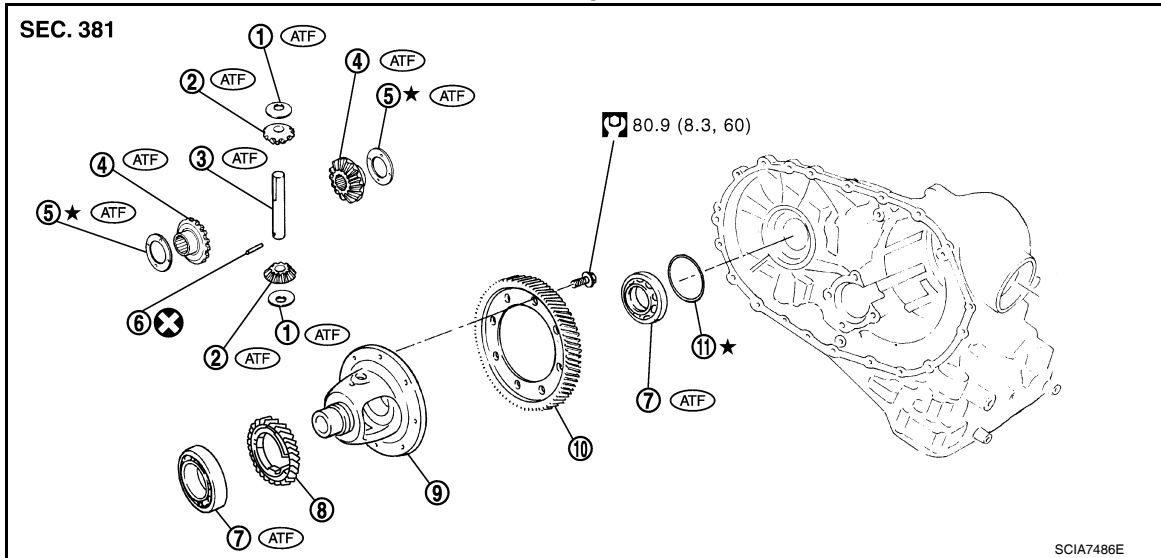

- | | | |
|-----------------------------------|--|----------------------|
| 1. Pinion mate gear thrust washer | 2. Pinion mate gear | 3. Pinion mate shaft |
| 4. Side gear | 5. Side gear thrust washer | 6. Lock pin |
| 7. Differential side bearing | 8. Speedometer drive gear | 9. Differential case |
| 10. Final gear | 11. Differential side bearing adjusting shim | |

MR18DE models

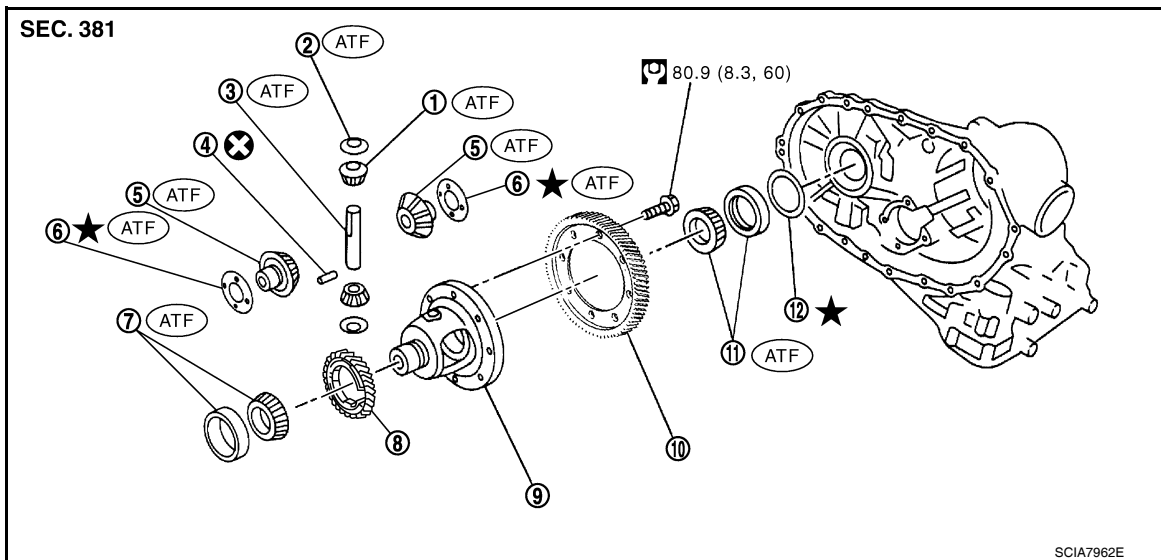

- | | | |
|------------------------------|-----------------------------------|--|
| 1. Pinion mate gear | 2. Pinion mate gear thrust washer | 3. Pinion mate shaft |
| 4. Lock pin | 5. Side gear | 6. Side gear thrust washer |
| 7. Differential side bearing | 8. Speedometer drive gear | 9. Differential case |
| 10. Final gear | 11. Differential side bearing | 12. Differential side bearing adjusting shim |

DISASSEMBLY

REPAIR FOR COMPONENT PARTS

< SERVICE INFORMATION >

1. Remove final gear (1) from differential case (2).

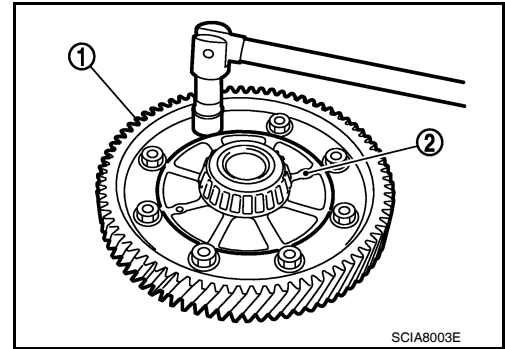

2. Remove differential side bearings according to the following procedures.

- a. HR16DE engine models

- i. Set a suitable tool (A) on differential case (1), and remove differential side bearing (RH side) (2) from differential case with suitable tool (B) and suitable tool (C).

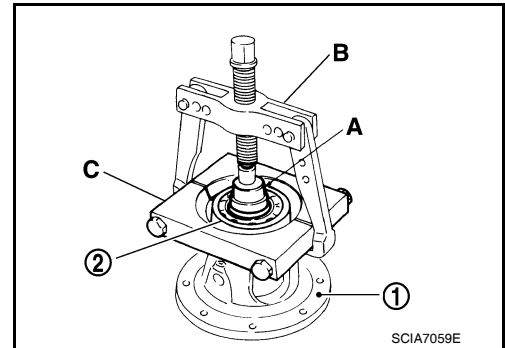

- ii. Set a suitable tool (A) on differential case (1), and remove differential side bearing (LH side) (2) from differential case with suitable tool (B).

CAUTION:

Be careful not to mix up the right and left bearings.

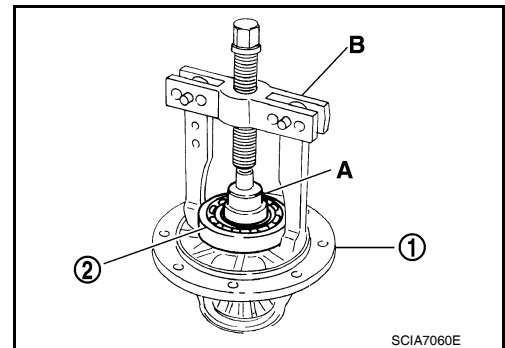

- b. MR18DE engine models

- i. Set Tool on differential case, and remove differential side bearings from differential case using a suitable tool.

Tool number : ST3306S001 (J-22888-D)

CAUTION:

Be careful not to mix up the right and left bearings.

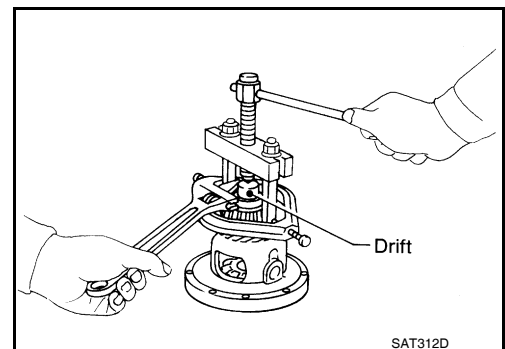

A
B
AT
D
E
F
G
H
I
J
K
L
M
N
O
P

REPAIR FOR COMPONENT PARTS

< SERVICE INFORMATION >

3. Remove speedometer drive gear from differential case.

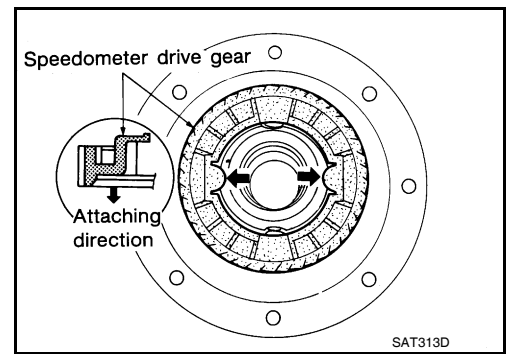

4. Drive out lock pin from differential case (1) using Tool (A).

Tool number : KV32101000 (J-25689-A)

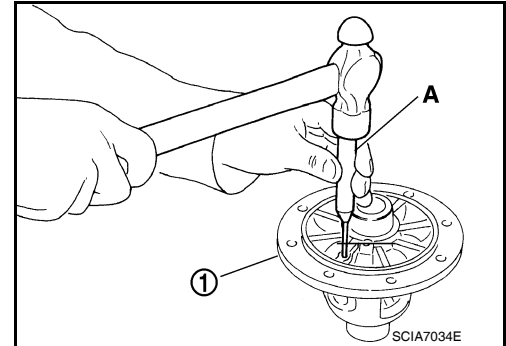

5. Draw out pinion mate shaft.

6. Remove pinion mate gears, pinion mate gear thrust washers, side gears and side gear thrust washers.

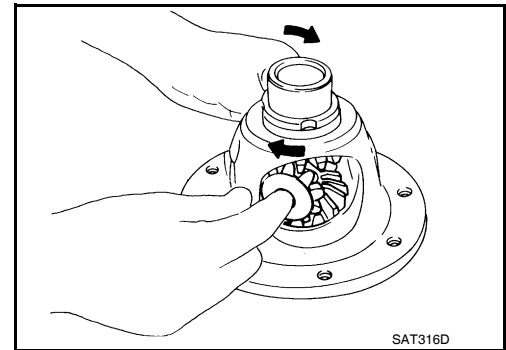

INSPECTION

Gears, Washers, Pinion Mate Shaft and Differential Case

- Check mating surfaces of differential case, side gears, pinion mate gears and pinion mate shaft. Replace if necessary.
- Check washers for wear. Replace if necessary.

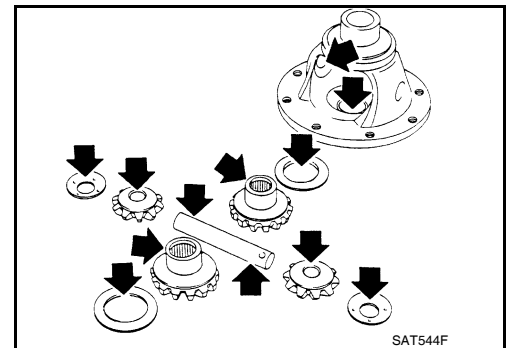

Bearings

REPAIR FOR COMPONENT PARTS

< SERVICE INFORMATION >

- Make sure bearings roll freely and are free from noise, cracks, pitting or wear. Replace if necessary.

CAUTION:

When replacing taper roller bearing, replace outer and inner race as a set.

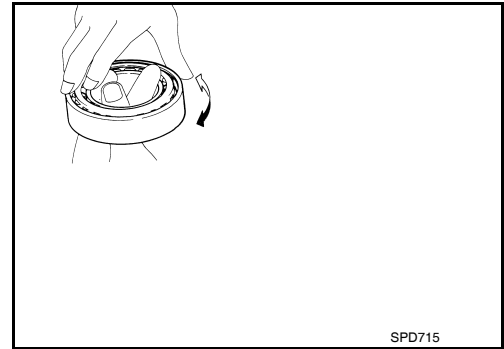

ASSEMBLY

1. Attach side gear thrust washers to side gears, then install pinion mate thrust washers and pinion mate gears in place.

CAUTION:

Apply ATF to any parts.

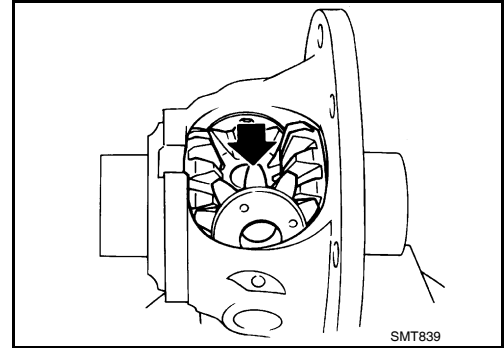

2. Insert pinion mate shaft.

CAUTION:

- When inserting, be careful not to damage pinion mate gear thrust washers.
- Apply ATF to pinion mate shaft.

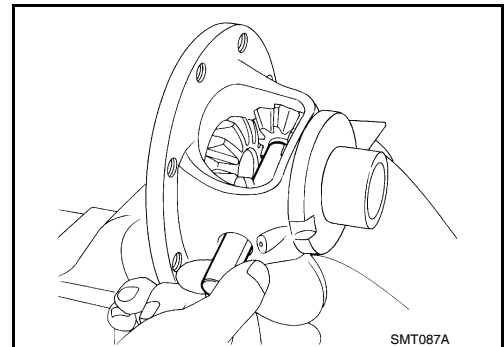

3. Select side gear thrust washers according to the following procedures.

- a. Place differential case in the upright position so that the side gear to be measured is at the top.

(A): Location for inserting feeler gauge

(B): Side gear tooth

(C): The center line of differential case

- b. In order to maximize the back clearance, rotate side gears so that a tooth on side gears at the top and bottom will align at the same position as shown.

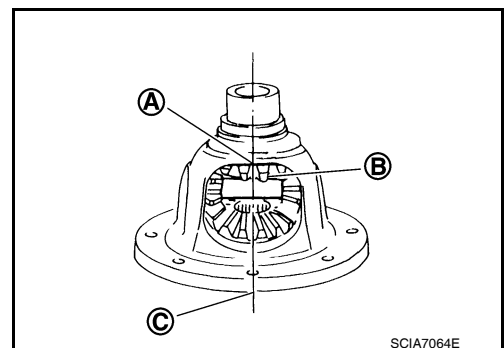

A
B
AT
D
E
F
G
H
I
J
K
L
M
N
O
P

REPAIR FOR COMPONENT PARTS

< SERVICE INFORMATION >

- c. Adjust the back clearance of side gear according to the following procedures.
 - i. Insert feeler gauges (A) of the same thickness to the back of side gear from both sides, preventing side gear from falling, to measure the clearance.
 - Measure clearance 3 times by rotating side gears and take the average.
- CAUTION:**
In all 3 measurements, maximize the clearance by aligning teeth on side gears at the top and bottom at the same position.
- ii. Select side gear thrust washer so that the clearance will fall within the standard.

Differential side gear clearance:

Refer to [AT-378, "Final Drive"](#).

- iii. Turn differential case upside down, and measure the back clearance of the other side gear in the same manner.

NOTE:

Adjust the clearance to approx. 0.1 mm (0.004 in) for used differential [driven approx. 3,000 km (1864 mile) or more].

4. Install lock pin (1) to pinion mate shaft using suitable tool (A).

Tool number A: KV32101000 (J-25689-A)

CAUTION:

- Do not reuse lock pin.
- Make sure that lock pin is flush with differential case.

5. Install speedometer drive gear on differential case.

6. Install output gear bearing (HR16DE engine models) or radial needle bearing (MR18DE engine models) according to the following procedures.

- a. HR16DE engine models

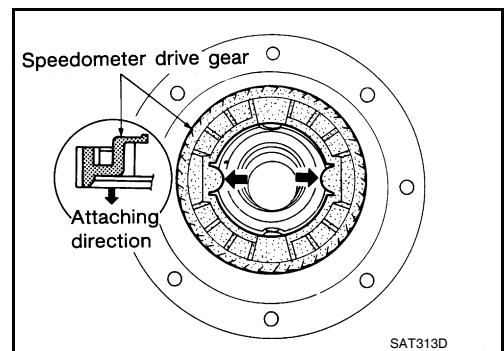
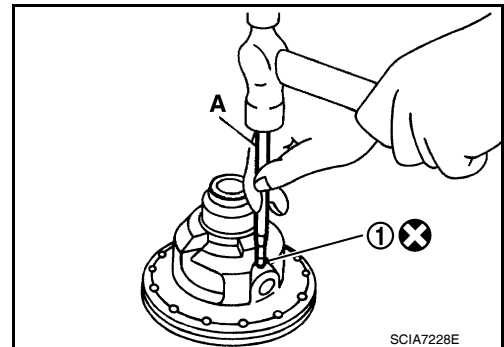
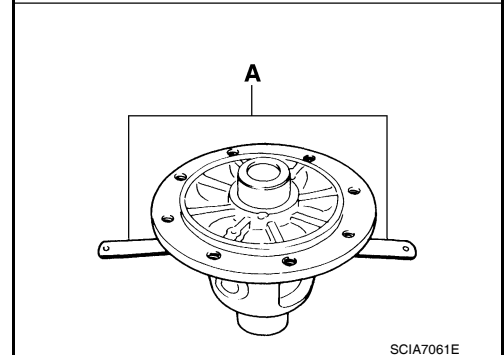
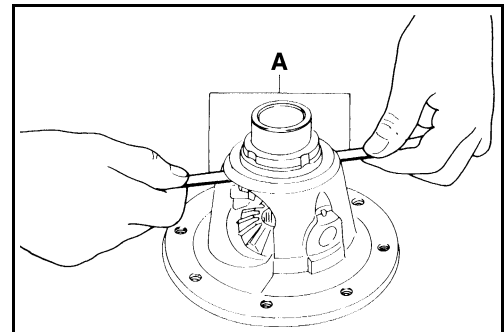

REPAIR FOR COMPONENT PARTS

< SERVICE INFORMATION >

- i. Set Tool (A) on differential side bearing (RH side) (1), and press differential side bearing (RH side) to differential case (2)

Tool number A: ST33200000 (J-26082)

CAUTION:

**Set Tool (A) on differential side bearing inner race.
Apply ATF to differential side bearings.**

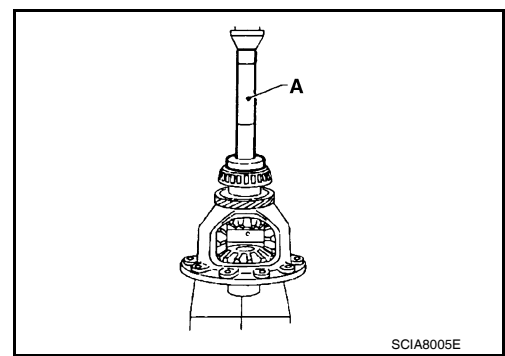

- ii. Set Tool (A) on differential side bearing (LH side) (1), and press differential side bearing (LH side) to differential case (2)

Tool number A: ST33200000 (J-26082)

CAUTION:

**Set Tool (A) on differential side bearing inner race.
Apply ATF to differential side bearings.**

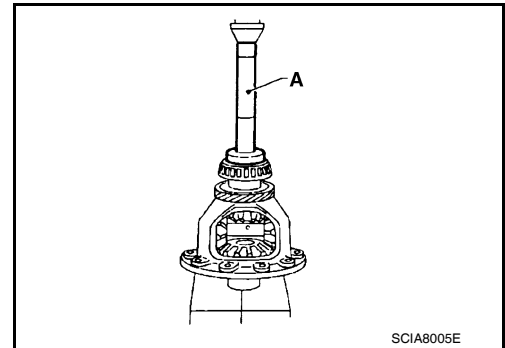

- b. MR18DE engine models

- i. Set suitable tool (A) on differential side bearing inner race, and press differential side bearing inner race into differential case.

CAUTION:

**Set Tool on differential side bearing inner race.
Apply ATF to differential side bearings.**

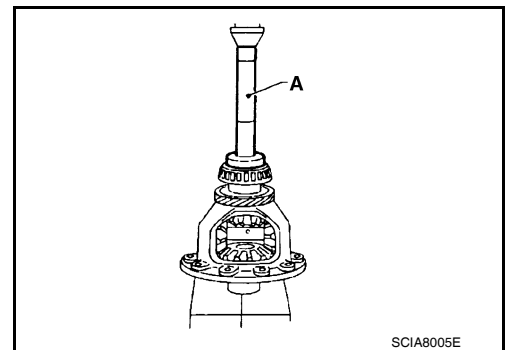

7. Install final gear and tighten bolts to the specified torque in numerical order as shown after temporarily tightening them. Refer to [AT-378, "Final Drive"](#).

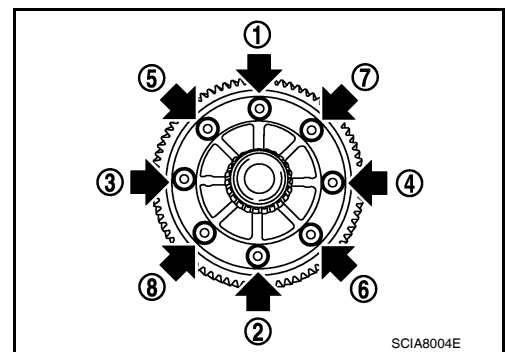

A
B
AT
D
E
F
G
H
I
J
K
L
M
N
O
P

ASSEMBLY

< SERVICE INFORMATION >

ASSEMBLY

Assembly (1)

INFOID:000000005928303

1. Drive each differential side oil seal evenly using Tools (Transaxle case side) and suitable tool (Converter housing side) so that differential side oil seal protrudes by the dimension (C) or (D) respectively.

- (1): LH differential side oil seal
- (2): RH differential side oil seal
- (A): Transaxle case side
- (B): Converter housing side

Tool numbers : ST35325000 (—)
: KV31103000 (J-38982)

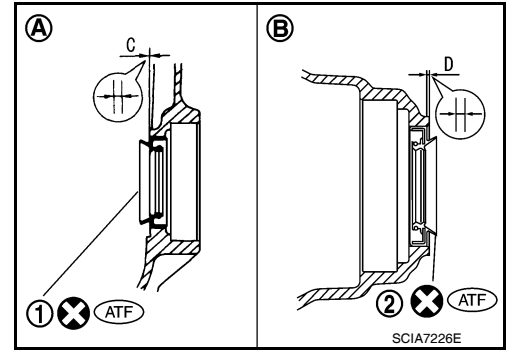

Unit: mm (in)

Applied model	HR16DE engine	MR18DE engine
Dimension (C)	0 ± 0.5 (0 ± 0.020)	0 ± 0.5 (0 ± 0.020)
Dimension (D)	1.1 ± 0.5 (0.043 ± 0.020)	6 ± 0.5 (0.24 ± 0.020)

NOTE:

Differential side oil seal pulling direction is used as the reference.

2. Install O-ring on governor cap.

CAUTION:

- Do not reuse O-ring.
- Apply ATF to O-ring.

3. Install governor cap in transaxle case.
4. Install snap ring in transaxle case.
5. Install parking actuator support (1) on transaxle case.

- (A): Inside
- (B): Outside

CAUTION:

Be careful with the direction of parking actuator support (1).

6. Tighten parking actuator support bolts to the specified torque. Refer to [AT-237. "Component"](#).

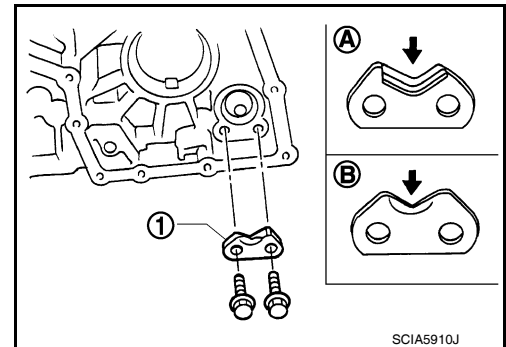

7. Install parking pawl (2) on transaxle case, and fix it with parking shaft (1).

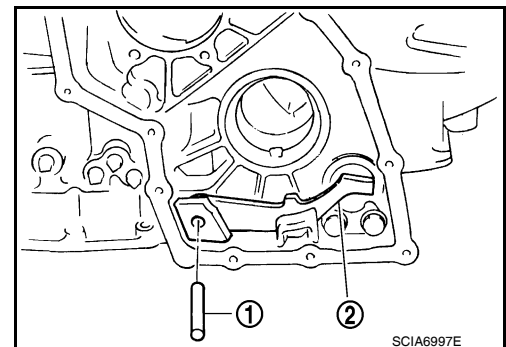

ASSEMBLY

< SERVICE INFORMATION >

8. Install return spring (2) on parking shaft (3) and parking pawl (1) using a suitable tool.

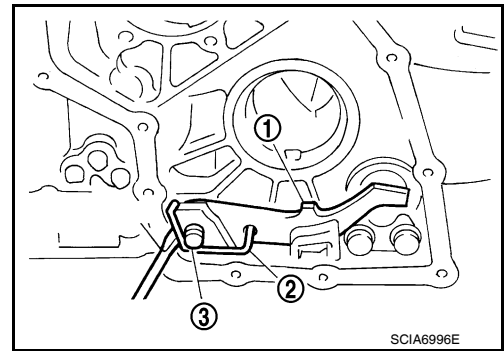

Adjustment (1) (For HR16DE Engine Models)

INFOID:000000005928304

REDUCTION PINION GEAR BEARING PRELOAD

1. Select proper thickness of reduction pinion gear adjusting shim using the following procedures.
 - a. Place reduction pinion gear on transaxle case as shown.
 - b. Install idler gear bearing outer race on transaxle case.

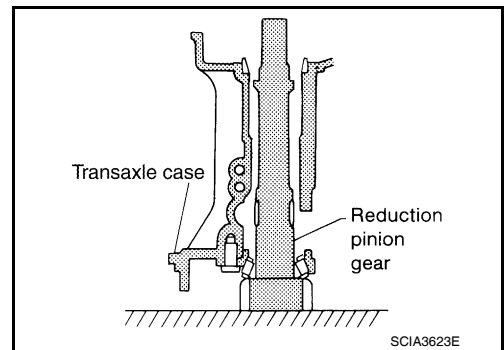

- c. Place idler gear bearing inner race on outer race.
- d. Measure dimensions (B), (C) and (D), and calculate dimension (A).

(A) : Distance between the surface of idler gear bearing inner race and the adjusting shim mating surface of reduction pinion gear.

$$A = D - (B + C)$$

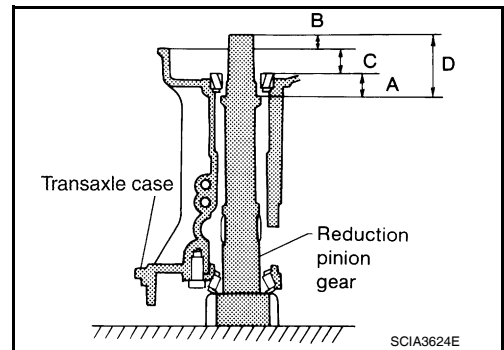

- Measure dimension (B) between the end of reduction pinion gear and the surface of transaxle case.
- **Measure dimension (B) in at least two places, and take the average.**

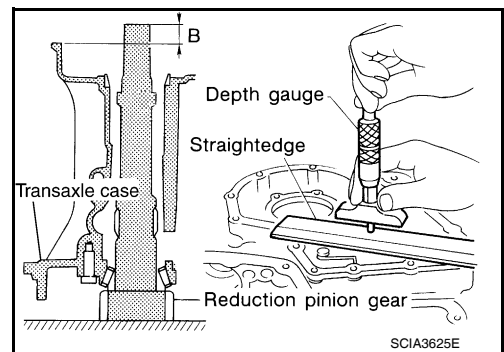

ASSEMBLY

< SERVICE INFORMATION >

- Measure dimension (C) between the surface of idler gear bearing inner race and the surface of transaxle case.
- **Measure dimension (C) in at least two places, and take the average.**

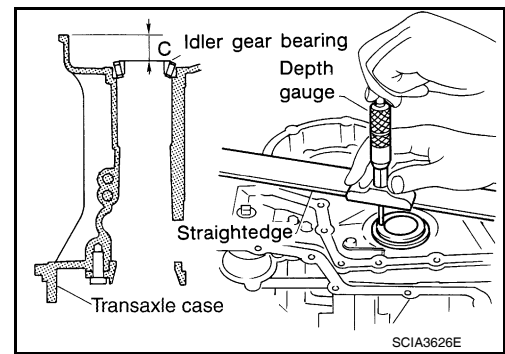

- Remove reduction pinion gear from transaxle case.
- Measure dimension (D) between the end of reduction pinion gear and the adjusting shim mating surface of reduction pinion gear.
- **Measure dimension (D) in at least two places, and take the average.**
- Calculate dimension (A).

$$A = D - (B + C)$$

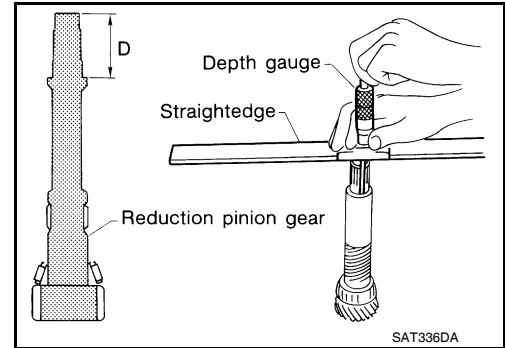

- Measure dimension (E) between the end of idler gear and idler gear bearing inner race mating surface of idler gear.
 - **Measure dimension (E) in at least two places, and take the average.**
- Select proper thickness of reduction pinion gear adjusting shim. Refer to [AT-374. "Adjusting shims, Needle Bearings, Thrust Washers and Snap Rings"](#) for reduction pinion gear adjusting shim selection.

Proper shim thickness = A – E – 0.05 mm (0.0020 in)*
 (*: Bearing preload)

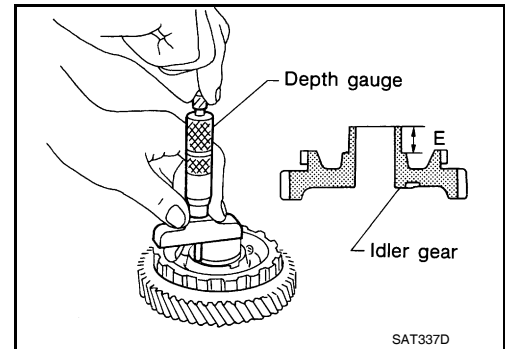

- Install reduction pinion gear and reduction pinion gear adjusting shim selected in step 1-f on transaxle case.
 - CAUTION:**
Apply ATF to reduction pinion gear bearing.
- Press idler gear bearing inner race on idler gear.
- Press idler gear on reduction pinion gear using Tool.

Tool number : ST35271000 (J-26091)

- CAUTION:**
- **Apply ATF to idler gear bearing.**
- **Press idler gear until idler gear fully contacts reduction pinion gear bearing adjusting shim.**

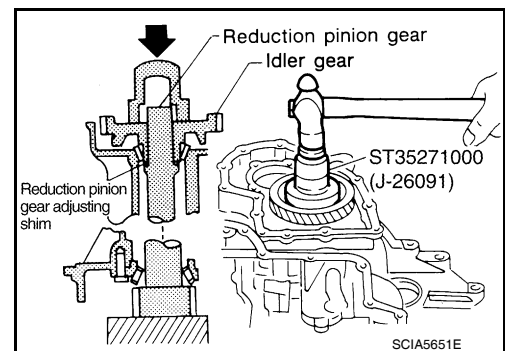

- Set manual shaft in "P" position to lock idler gear.
- Tighten lock nut of idler gear to the specified torque. Refer to [AT-237. "Component"](#).
 - CAUTION:**
Lock idler gear with parking pawl when tightening lock nut.

ASSEMBLY

< SERVICE INFORMATION >

7. Measure turning torque of reduction pinion gear using Tool.

Tool number : ST3127S000 (J-25765-A)

Turning torque of reduction pinion gear:

Refer to [AT-378](#), "Reduction Pinion Gear".

- When measuring turning torque, turn reduction pinion gear in both directions several times to seat bearing rollers correctly.
- If turning torque is out of specification, decrease or increase thickness of reduction pinion gear adjusting shim.

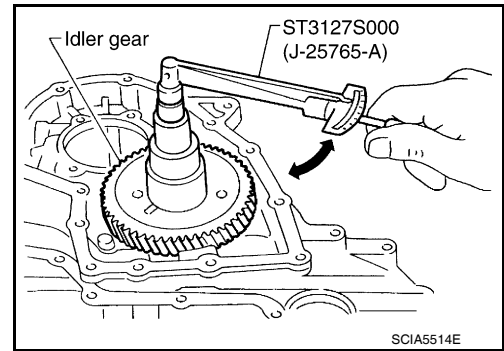

OUTPUT SHAFT BEARING PRELOAD

1. Select proper thickness of output gear adjusting spacer using the following procedures.
 - a. Remove paper rolled around output shaft.
 - b. Install output gear bearing outer race on bearing retainer.
 - c. Place bearing retainer on output shaft.

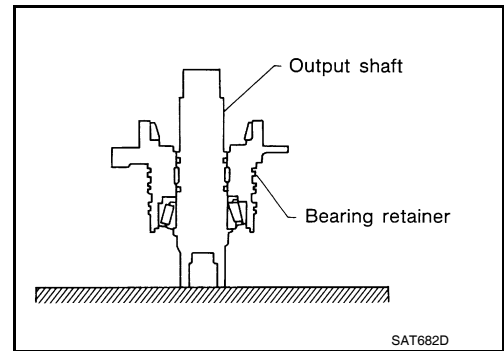

- d. Place output gear bearing inner race on bearing retainer.
- e. Measure dimensions (G) and (H), and calculate dimension (F).

(F) : Distance between the surface of output gear bearing inner race and adjusting spacer mating surface of output shaft.

$$F = H - G$$

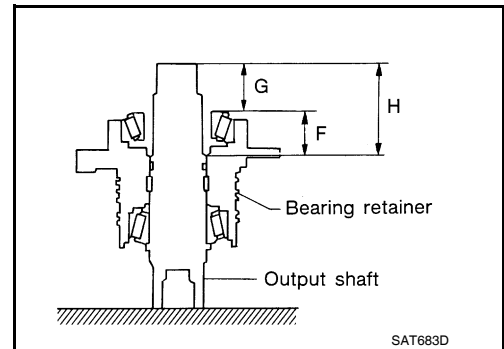

- Measure dimension (G) between end of output shaft and surface of output gear bearing inner race.
- **Measure dimension (G) in at least two places, and take the average.**

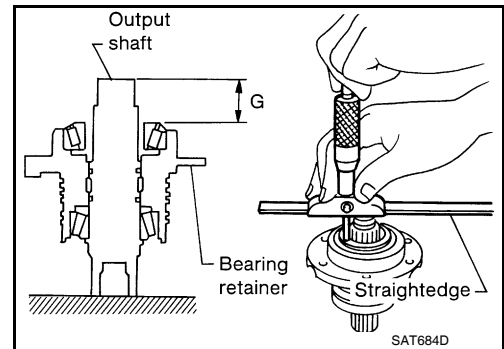

ASSEMBLY

< SERVICE INFORMATION >

- Measure dimension (H) between end of output shaft and adjusting spacer mating surface of output shaft.
- **Measure dimension (H) in at least two places, and take the average.**
- Calculate dimension (F).

$$F = H - G$$

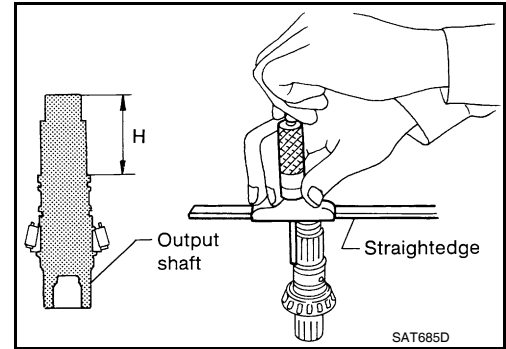

- f. Measure dimension (I) between end of output gear (adjusting spacer mating surface) and output gear bearing inner race surface.
- **Measure dimension (I) in at least two places, and take the average.**
- g. Select proper thickness of output gear adjusting spacer. Refer to "Parts Information" for output gear adjusting spacer selection.

Proper spacer thickness

$$= F - I - [0.03 - 0.08 \text{ mm (0.0012 - 0.0031 in)}]^*$$

(*: Bearing preload)

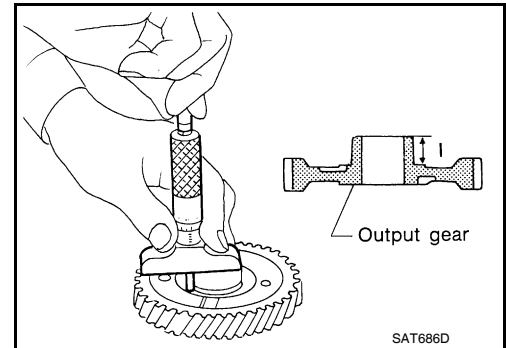

2. Install bearing retainer (1) in transaxle case.
3. Tighten bearing retainer bolts to the specified torque.

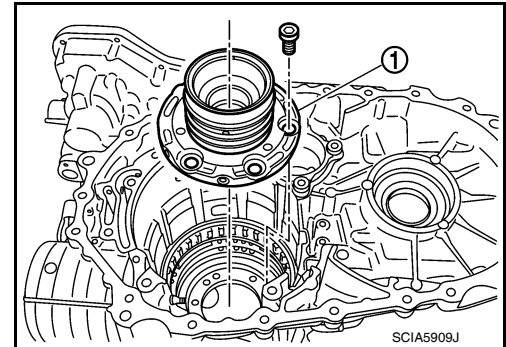

4. Install output shaft (1) and output gear adjusting spacer (2) selected in step 1-f on transaxle case.

CAUTION:

- Apply ATF to output shaft bearing.
- Do not force output shaft to install or seal ring may be damaged.

5. Press output gear bearing inner race on output gear (3).
6. Set Tool (A) on output gear (3), and press output gear (3) on output shaft (1).

CAUTION:

- Apply ATF to output gear bearing.
- Do not pinch seal ring when output shaft is pressed in.
- Press output gear (3) until output gear (3) fully contacts output gear adjusting space (2).

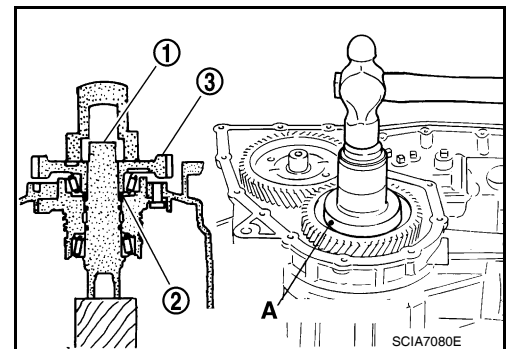

Tool number : ST35271000 (J-26091)

7. Set manual shaft in "P" position to lock idler gear.
8. Tighten lock nut of output gear to the specified torque. [AT-237, "Component"](#).

CAUTION:

- Do not reuse lock nut.
- Lock idler gear with parking pawl when tightening lock nut.

ASSEMBLY

< SERVICE INFORMATION >

9. Remove idler gear (1) using Tool (A) to measure output shaft bearing preload.

Tool number : ST27180001 (J-25726-A)

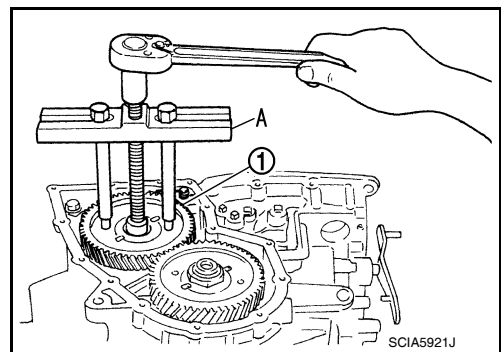

10. Measure turning torque of output shaft using Tool.

Tool number : ST3127S000 (J-25765-A)

Turning torque of output shaft:
Refer to [AT-379. "Output Shaft"](#).

- When measuring turning torque, turn output shaft in both directions several times to seat bearing rollers correctly.
- If turning torque is out of specification, decrease or increase thickness of output gear adjusting spacer.

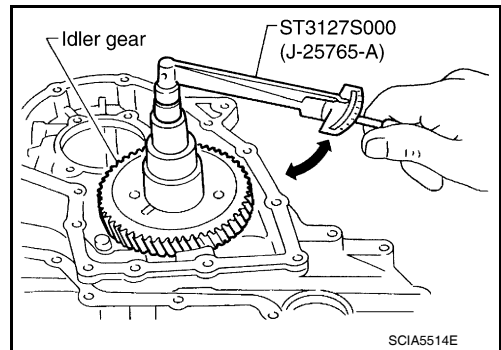

11. Press idler gear on reduction pinion gear.
12. Tighten lock nut (1) of idler gear to the specified torque. Refer to [AT-237. "Component"](#).
13. After properly adjusting turning torque, clinch lock nuts (1) of idler gear and output gear as shown.

L1 : 3 mm (0.12 in) or more
L2 : 1 mm (0.04 in) or more

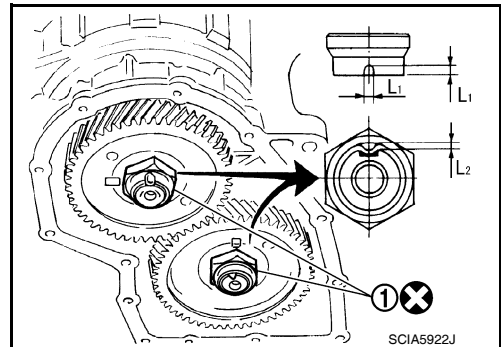

14. Install side cover gasket and side cover on transaxle case.
- CAUTION:**
- Do not reuse side cover gasket.
 - Completely remove all moisture, oil and old gasket, etc. from the transaxle case and side cover mating surfaces.
15. Tighten side cover bolts (1) to the specified torque. Refer to [AT-237. "Component"](#).

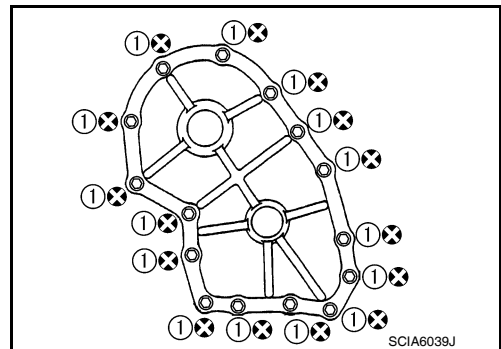

Adjustment (1) (For MR18DE Engine Models)

INFOID:000000005928305

DIFFERENTIAL SIDE BEARING PRELOAD

1. Select proper thickness of differential side bearing adjusting shim using the following procedures.

ASSEMBLY

< SERVICE INFORMATION >

- Install differential side bearing outer race without differential side bearing adjusting shim on transaxle case.

CAUTION:

Apply ATF to differential side bearing outer race.

- Install differential side bearing outer race on converter housing.

Tool number : ST30633000 (—)

CAUTION:

Apply ATF to differential side bearing outer race.

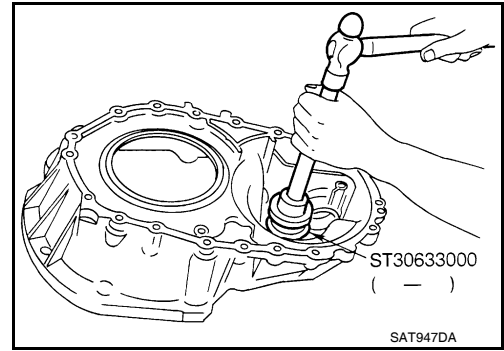

- Place final drive assembly on transaxle case.
- Tighten converter housing bolts (1) and (2) to the specified torque. Refer to [AT-337. "Final Drive"](#).

Bolt	1	2
Bolt length [mm (in)]	32.8 (1.291)	40 (1.57)
		
Number of bolts	10	10

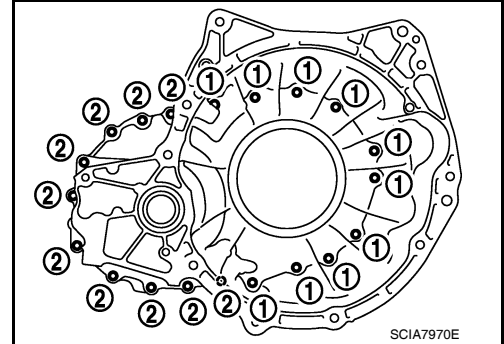

- Attach dial indicator on differential case at converter housing side.
- Insert Tool into differential side gear from transaxle case side.

Tool number : KV38105710 (J-39026)

- Move Tool up and down and measure dial indicator deflection.
- Select proper thickness of differential side bearing adjusting shim. Refer to "Parts Information" for differential side bearing adjusting shim selection. Refer to [AT-374. "Adjusting shims. Needle Bearings, Thrust Washers and Snap Rings"](#).
Suitable shim thickness = Dial indicator deflection + Specified bearing preload

Suitable shim thickness = Dial indicator deflection + Specified bearing preload

Bearing preload: Refer to [AT-378. "Final Drive"](#).

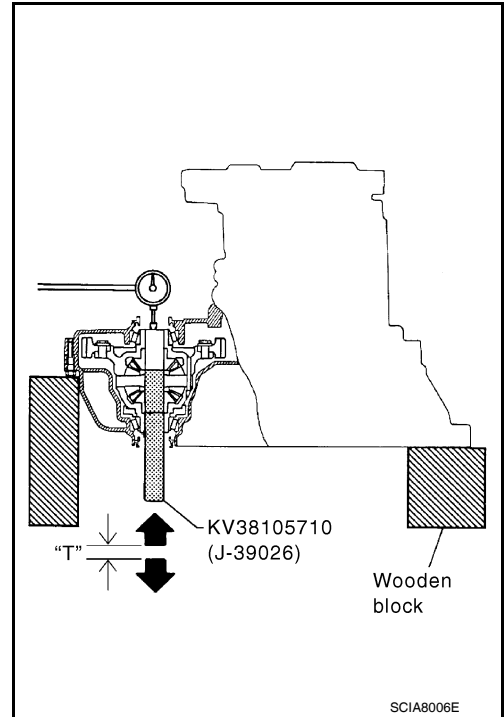

- Remove converter housing from transaxle case.
- Remove final drive assembly from transaxle case.
- Remove differential side bearing outer race from transaxle case using Tool.

Tool number : KV381054S0 (J-34286)

- Reinstall differential side bearing outer race and differential side bearing adjusting shim selected from "Parts Information" on transaxle case.

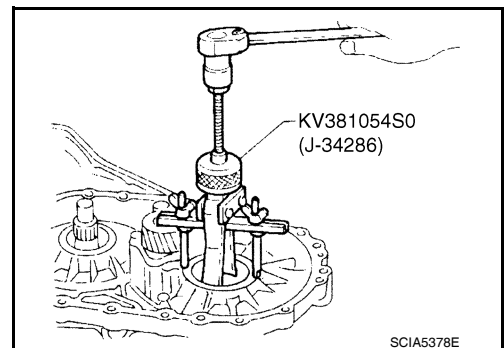

ASSEMBLY

< SERVICE INFORMATION >

- m. Reinstall converter housing on transaxle case and tighten converter housing bolts to the specified torque. Refer to [AT-237, "Component"](#).
- n. Insert Tool and measure turning torque of final drive assembly.

Tool number : KV38105710 (J-39026)

- Turn final drive assembly in both directions several times to seat bearing rollers correctly.

**Turning torque of final drive assembly
(New bearing):**

Refer to [AT-378, "Final Drive"](#).

- When old bearing is used again, turning torque will be slightly less than the above.
- Make sure torque is close to the specified range.

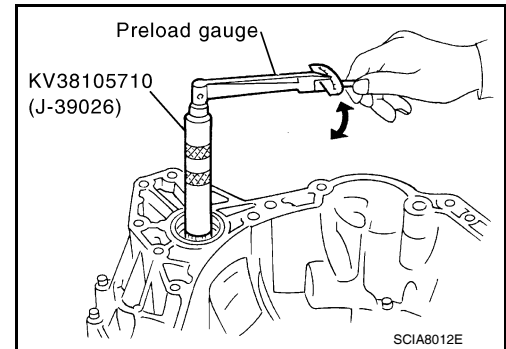

REDUCTION PINION GEAR BEARING PRELOAD

1. Select proper thickness of reduction pinion gear adjusting shim using the following procedures.
 - a. Place reduction pinion gear on transaxle case as shown in the figure.
 - b. Install idler gear bearing outer race on transaxle case. Refer to [AT-322, "Output Shaft, Output Gear, Idler Gear, Reduction Pinion Gear and Bearing Retainer"](#).

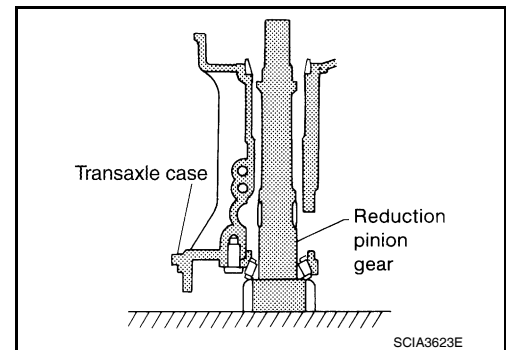

- c. Place idler gear bearing inner race on outer race.
 - d. Measure dimensions (B), (C) and (D), and calculate dimension (A).

(A) : Distance between the surface of idler gear bearing inner race and the adjusting shim mating surface of reduction pinion gear.

$$A = D - (B + C)$$

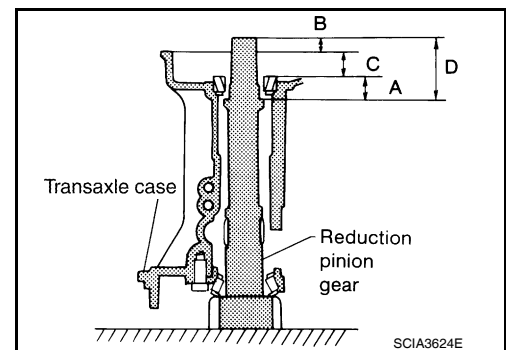

- Measure dimension (B) between the end of reduction pinion gear and the surface of transaxle case.
- Measure dimension (B) in at least two places, and take the average.

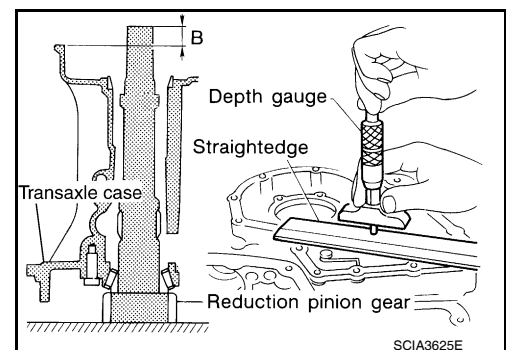

ASSEMBLY

< SERVICE INFORMATION >

- Measure dimension (C) between the surface of idler gear bearing inner race and the surface of transaxle case.
- **Measure dimension (C) in at least two places, and take the average.**

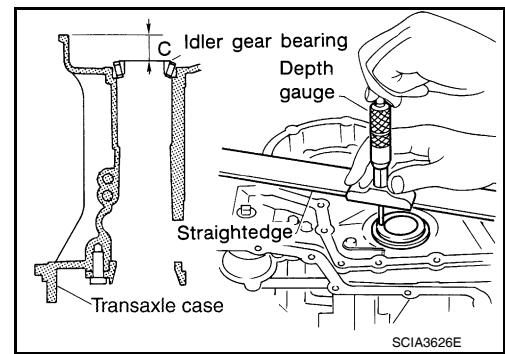

- Remove reduction pinion gear from transaxle case.
- Measure dimension (D) between the end of reduction pinion gear and the adjusting shim mating surface of reduction pinion gear.
- **Measure dimension (D) in at least two places, and take the average.**
- Calculate dimension (A).

$$A = D - (B + C)$$

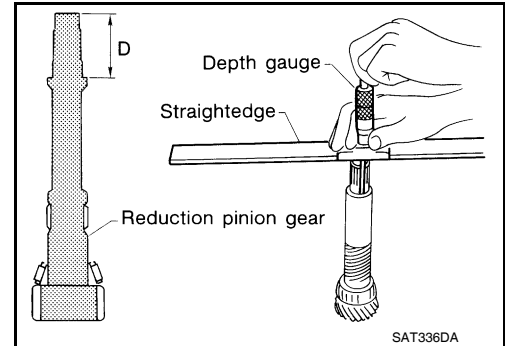

- Measure dimension (E) between the end of idler gear and idler gear bearing inner race mating surface of idler gear.
 - **Measure dimension (E) in at least two places, and take the average.**
- Select proper thickness of reduction pinion gear adjusting shim. Refer to "Parts Information" for reduction pinion gear adjusting shim selection.

Proper shim thickness = $A - E - 0.05 \text{ mm (0.0020 in)*}$
 (*: Bearing preload)

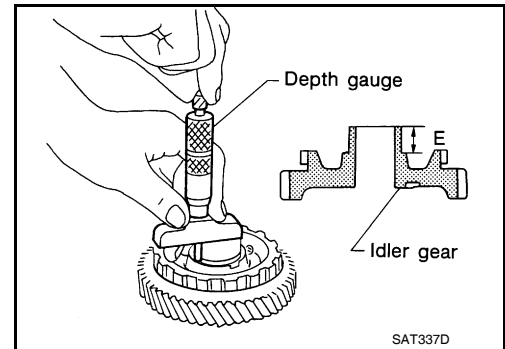

- Install reduction pinion gear and reduction pinion gear adjusting shim selected in step 1-f on transaxle case.

CAUTION:

Apply ATF to reduction pinion gear bearing.

- Press idler gear bearing inner race on idler gear. Refer to [AT-322, "Output Shaft, Output Gear, Idler Gear, Reduction Pinion Gear and Bearing Retainer"](#).

- Press idler gear on reduction pinion gear using Tool.

Tool number : ST35271000 (J-26091)

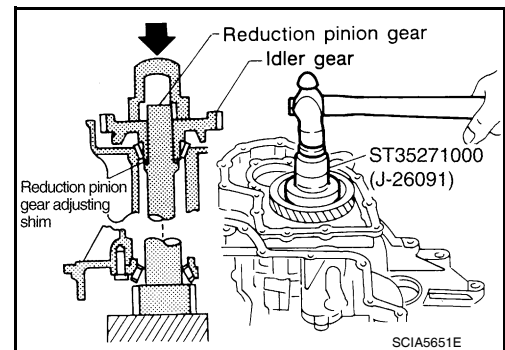

CAUTION:

• **Apply ATF to idler gear bearing.**

• **Press idler gear until idler gear fully contacts reduction pinion gear bearing adjusting shim.**

- Set manual shaft in "P" position to fix idler gear.

- Tighten lock nut of idler gear to the specified torque. Refer to [AT-237, "Component"](#).

CAUTION:

Lock idler gear with parking pawl when tightening lock nut.

ASSEMBLY

< SERVICE INFORMATION >

7. Measure turning torque of reduction pinion gear using Tool.

Tool number : ST3127S000 (J-25765-A)

Turning torque of reduction pinion gear:

Refer to [AT-378, "Reduction Pinion Gear"](#).

- When measuring turning torque, turn reduction pinion gear in both directions several times to seat bearing rollers correctly.
- If turning torque is out of specification, decrease or increase thickness of reduction pinion gear adjusting shim.

8. After properly adjusting turning torque, clinch idler gear lock nut as shown.

CAUTION:

Do not reuse idler gear lock nut.

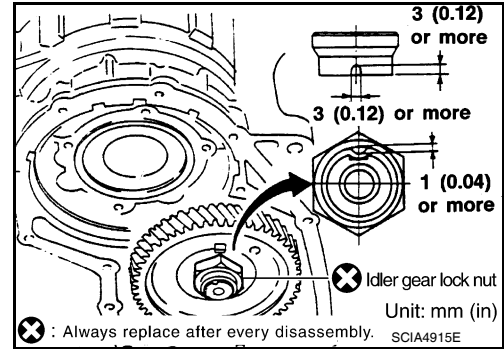
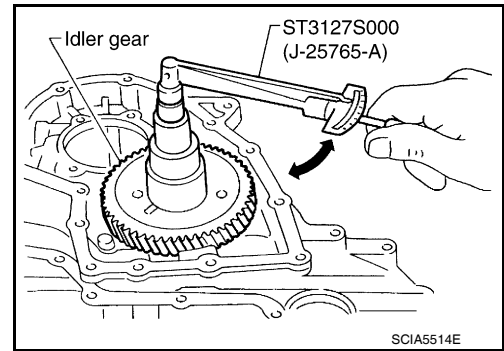

OUTPUT SHAFT END PLAY

1. Select proper thickness of output shaft adjusting shim using the following procedures.

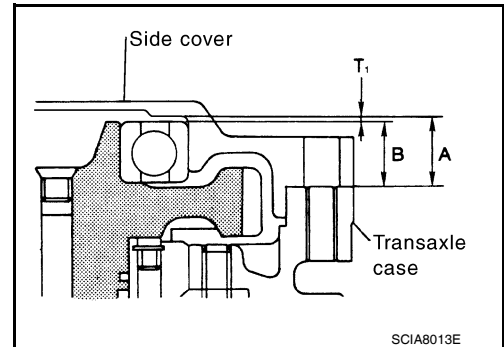

a. Install bearing retainer (1) in transaxle case. Refer to [AT-322, "Output Shaft, Output Gear, Idler Gear, Reduction Pinion Gear and Bearing Retainer"](#).

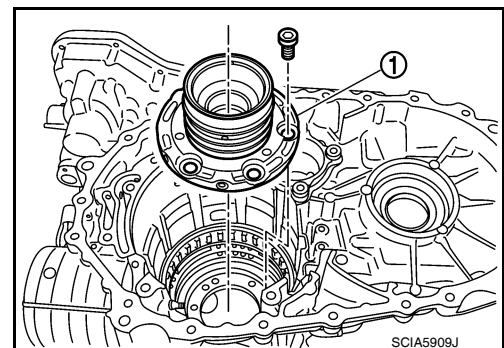

ASSEMBLY

< SERVICE INFORMATION >

- b. Install needle bearing on bearing retainer.

CAUTION:

Be careful to direction of needle bearing.

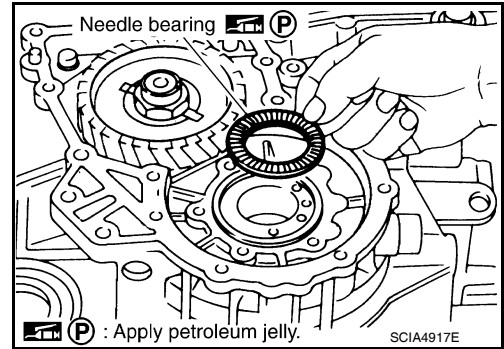

- c. Install output shaft on transaxle case.

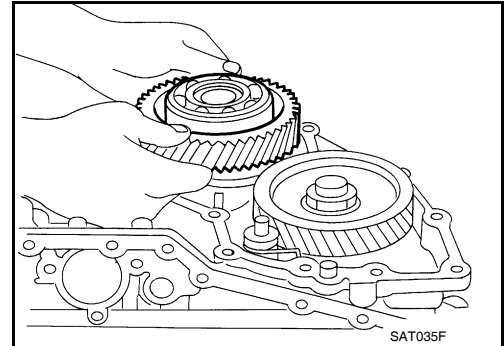

- d. Measure dimensions (ℓ_1) and (ℓ_2) at side cover and then calculate dimension (A).

- Measure dimension (ℓ_1) and (ℓ_2) in at least two places.

(A) : Distance between transaxle case fitting surface and adjusting shim mating surface.

$$A = \ell_1 - \ell_2$$

ℓ_2 : Height of gauge

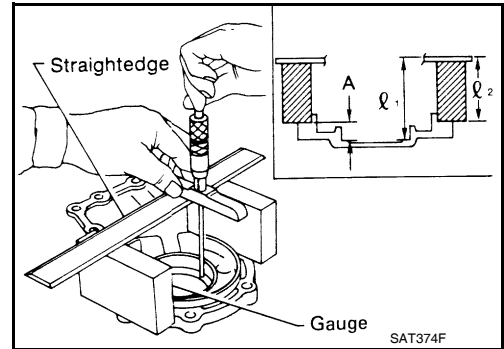

- e. Measure dimensions (ℓ_2) and (ℓ_3) and then calculate dimension (B).

- Measure dimension (ℓ_2) and (ℓ_3) in at least two places.

(B) : Distance between the end of output shaft bearing outer race and the side cover fitting surface of transaxle case.

$$B = \ell_2 - \ell_3$$

ℓ_2 : Height of gauge

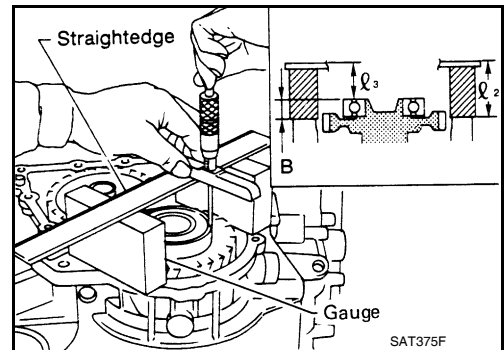

- f. Select proper thickness of output shaft adjusting shim so that output shaft end play (clearance between side cover and output shaft bearing) is within specifications. Refer to "Parts Information" for output shaft adjusting shim selection.

Output shaft end play (A – B):

Refer to AT-379, "Output Shaft".

- g. Install output shaft adjusting shim on output shaft bearing.

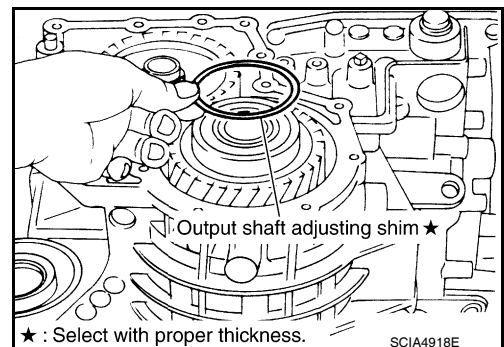

ASSEMBLY

< SERVICE INFORMATION >

- Apply recommended sealant (Genuine Anaerobic Liquid Gasket or equivalent.) to transaxle case as shown.

⇐: Inside of side cover

- (A) : 3 - 5 mm (0.12 - 0.20 in)
- (B) : 8 mm (0.31 in) R
- (C) : 1.5 mm (0.059 in) dia.
- (D) : 4 mm (0.16 in)

CAUTION:

- Apply the sealant on the center between the bolt holes.
- Completely remove all moisture, oil and old sealant, etc. from the transaxle case and side cover mounting surfaces.

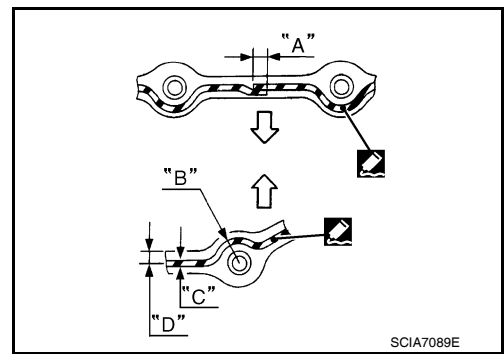

- Fit mounting part of output shaft bearing on side cover to output shaft bearing, and after adjusting knock pin position, install it with light taps of a soft hammer and things like that.

CAUTION:

When installing, to avoid getting damaged and deformed, set mounting part straight to parallel with the mounting surface.

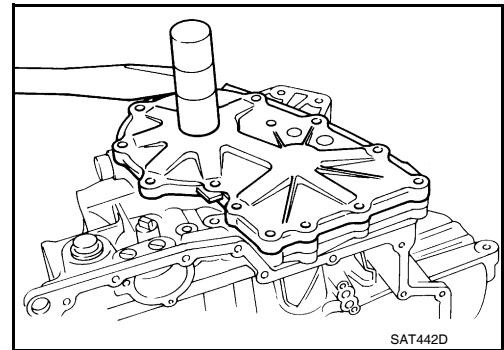

- Tighten side cover bolts to specified torque. Refer to [AT-237](#), "[Component](#)".

CAUTION:

- Do not mix bolts (A) and (B).
- Always replace bolts (A) as they are self-sealing bolts.

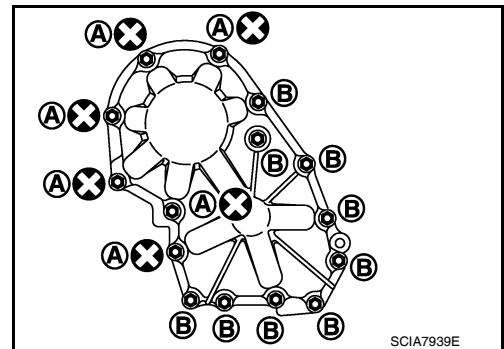

Assembly (2)

INFOID:000000005928306

- Remove paper rolled around bearing retainer.
- Install thrust washer on bearing retainer.

CAUTION:

Align pawls of thrust washer with holes of bearing retainer.

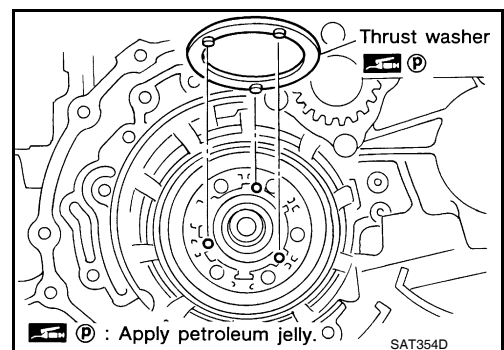

ASSEMBLY

< SERVICE INFORMATION >

3. Install forward clutch assembly and overrun clutch assembly (1) into transaxle case.

CAUTION:

- Align teeth of low & reverse brake drive plates before installing.
- Make sure that bearing retainer seal rings are not spread.

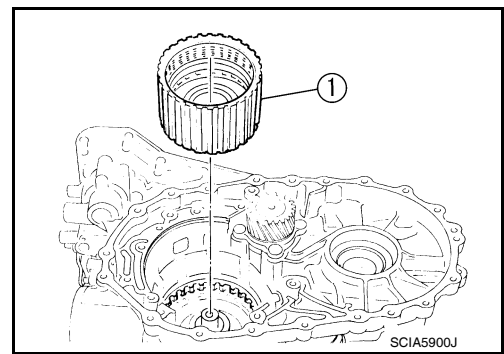

4. Install needle bearing (1) on bearing retainer.

CAUTION:

Be careful with the direction of needle bearing.

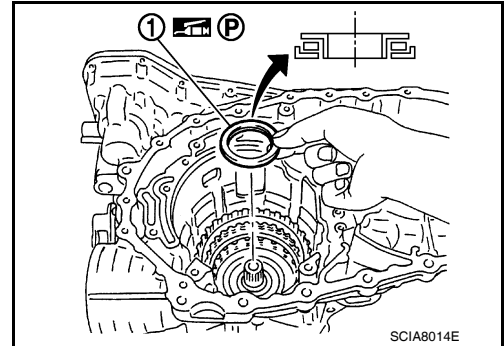

5. Install thrust washer (1) on overrun clutch hub (2).

CAUTION:

Align pawls of thrust washer (1) with holes of overrun clutch hub (2).

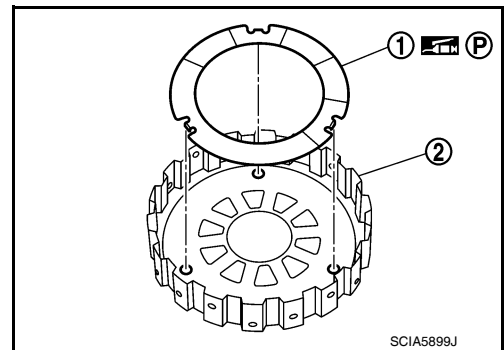

6. Install overrun clutch hub (1) into forward clutch drum.

CAUTION:

Align teeth of overrun clutch drive plates before installing.

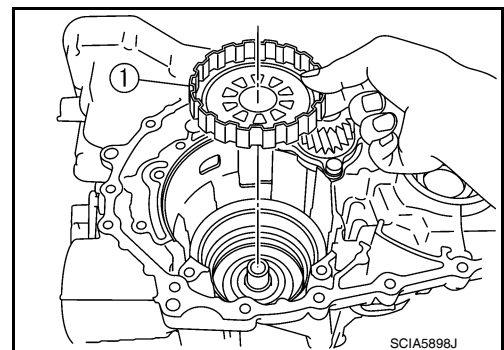

7. Hold forward clutch hub, and check that rear internal gear locks when tried to rotate counterclockwise.

CAUTION:

If rear internal gear rotates counterclockwise, check installation direction of forward one-way clutch.

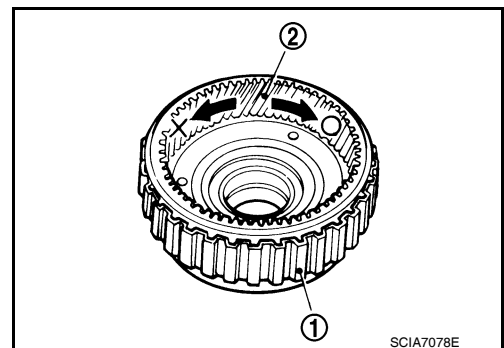

ASSEMBLY

< SERVICE INFORMATION >

8. Install needle bearing (1) on rear internal gear (2).

CAUTION:

Be careful with the direction of needle bearing (1).

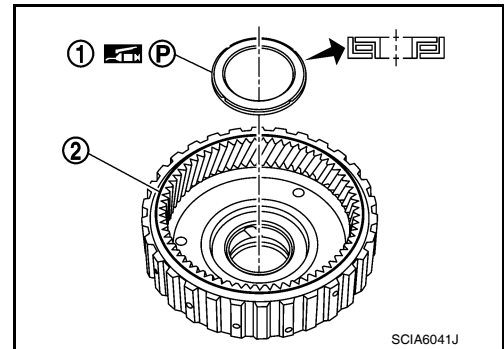

9. Install rear internal gear (1) and forward clutch hub (2) as a set into forward clutch drum.

CAUTION:

Align teeth of forward clutch drive plates before installing.

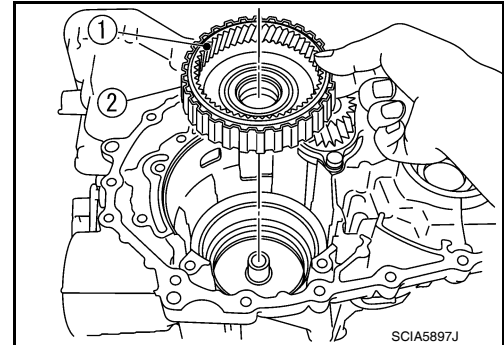

10. Install needle bearing (1) on rear planetary carrier (2).

CAUTION:

Be careful with the direction of needle bearing (1).

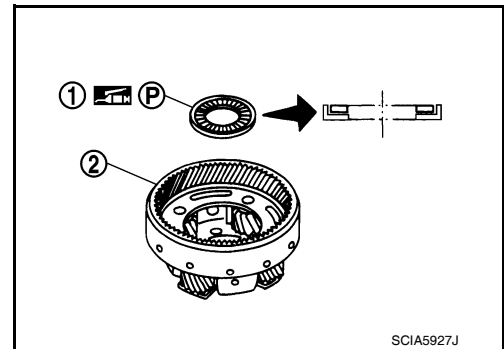

11. Install rear sun gear on rear planetary carrier.

CAUTION:

Be careful with the direction of rear sun gear.

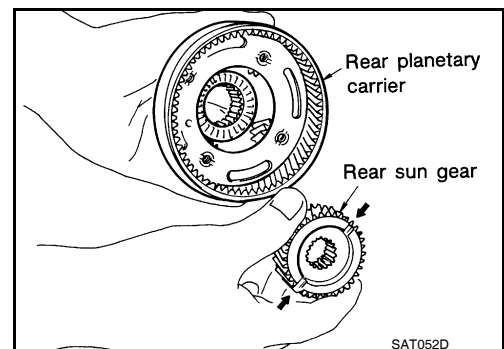

12. Install rear planetary carrier in transaxle case.

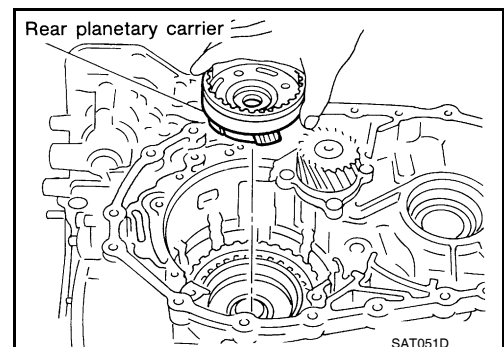

A
B
AT
D
E
F
G
H
I
J
K
L
M
N
O
P

ASSEMBLY

< SERVICE INFORMATION >

13. Install needle bearing (1) on front planetary carrier (2).

CAUTION:

Be careful with the direction of needle bearing (1).

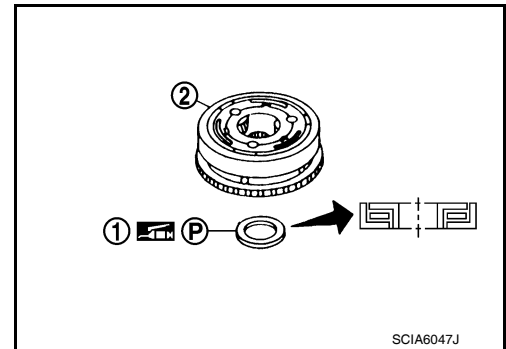

14. Install low one-way clutch to front planetary carrier by turning it in the direction of unlock.

15. Check that low one-way clutch rotates counterclockwise around front planetary carrier. Then try to turn it clockwise and check that it is locked.

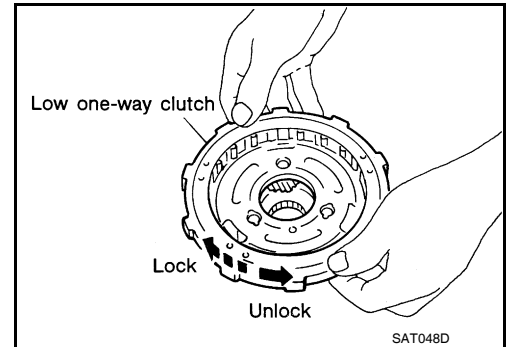

16. Install front planetary carrier (2) and low one-way clutch (1) as a set into transaxle case.

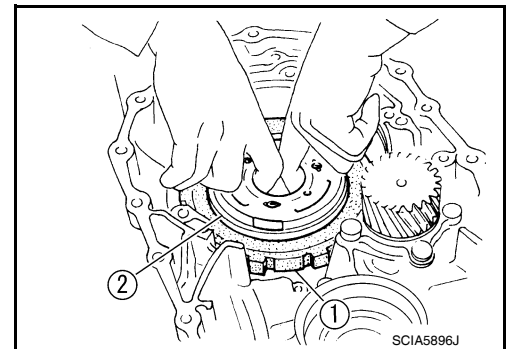

17. Install snap ring into transaxle case using a flat-bladed screwdriver.

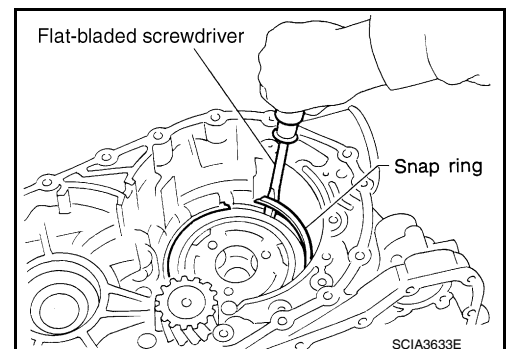

18. Install needle bearing (1) on front sun gear (2).

CAUTION:

Be careful with the direction of needle bearing (1).

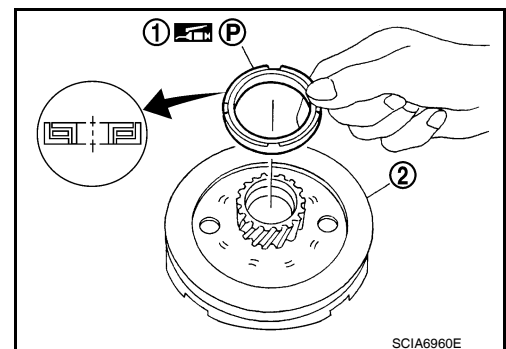

ASSEMBLY

< SERVICE INFORMATION >

19. Install front sun gear on front planetary carrier.

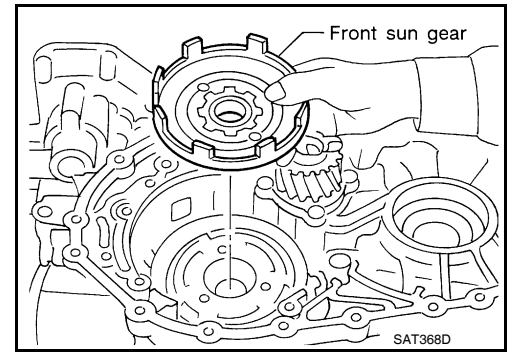

20. Install needle bearing on front sun gear.

CAUTION:

Be careful with the direction of needle bearing.

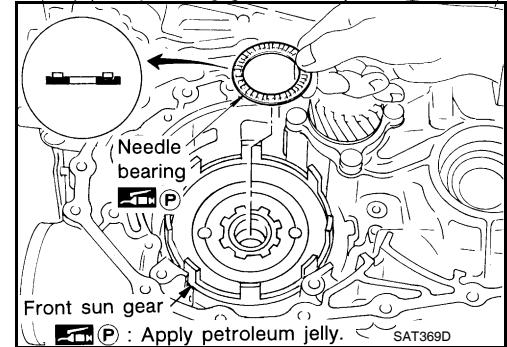

21. Install high clutch hub on front sun gear.

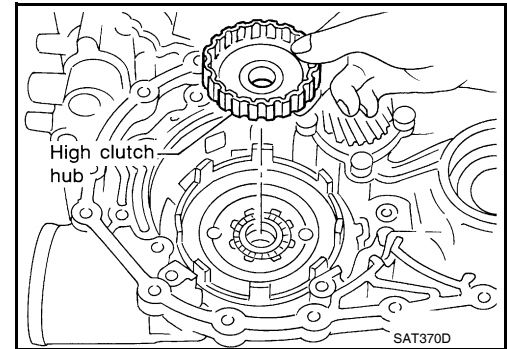

22. Install needle bearing on high clutch hub.

CAUTION:

Be careful with the direction of needle bearing.

23. Remove paper rolled around input shaft assembly (high clutch drum).

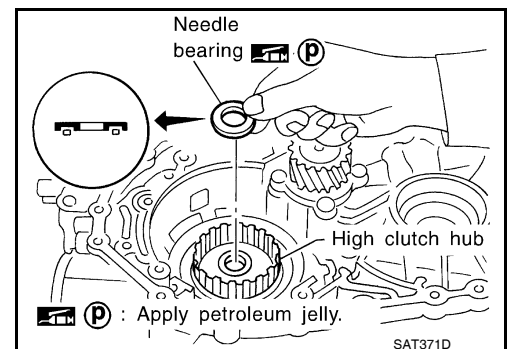

24. Install input shaft assembly (high clutch assembly) (1).

CAUTION:

Align teeth of high clutch drive plates before installing.

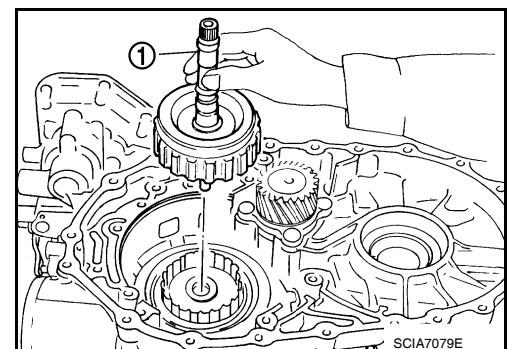

A
B
AT
D
E
F
G
H
I
J
K
L
M
N
O
P

ASSEMBLY

< SERVICE INFORMATION >

25. Install reverse clutch assembly.

CAUTION:

Align teeth of reverse clutch drive plates before installing.

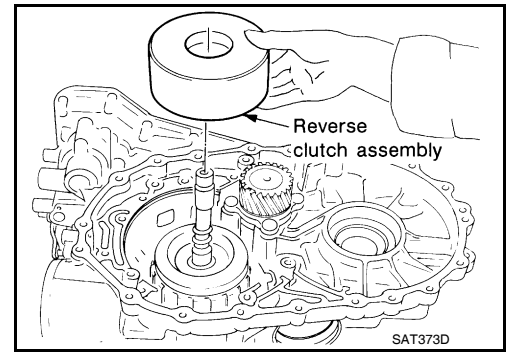

Adjustment (2)

INFOID:000000005928307

When any parts listed below are replaced, adjust total end play and reverse clutch end play.

Part name	Total end play	Reverse clutch end play
Transaxle case	●	●
Overrun clutch hub	●	●
Rear internal gear	●	●
Rear planetary carrier	●	●
Rear sun gear	●	●
Front planetary carrier	●	●
Front sun gear	●	●
High clutch hub	●	●
Input shaft assembly (high clutch drum)	●	●
Oil pump cover	●	●
Reverse clutch drum	—	●

TOTAL END PLAY

- Measure clearance between reverse clutch drum and needle bearing for oil pump cover.
- Select proper thickness of bearing race so that end play is within specifications.

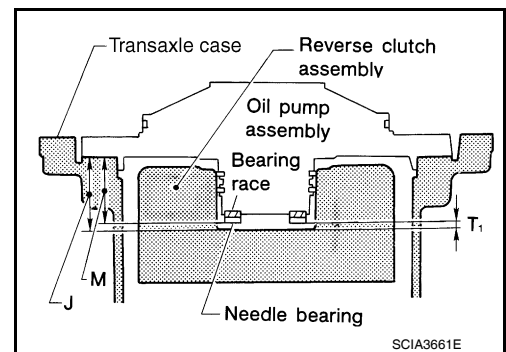

1. Measure dimensions (K) and (L), and then calculate dimension (J).

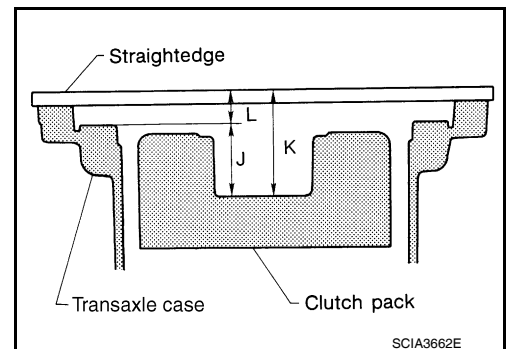

ASSEMBLY

< SERVICE INFORMATION >

- a. Measure dimension (K).

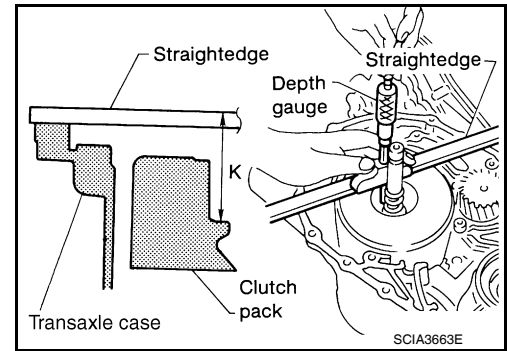

- b. Measure dimension (L).
c. Calculate dimension (J).

(J) : Distance between oil pump fitting surface of transaxle case and needle bearing mating surface of input shaft assembly (high clutch drum).

$$J = K - L$$

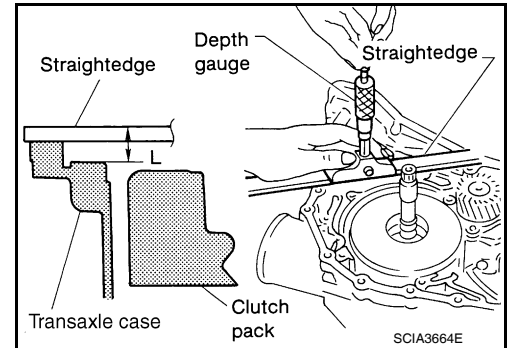

2. Measure dimension (M).
a. Place bearing race and needle bearing on oil pump assembly.

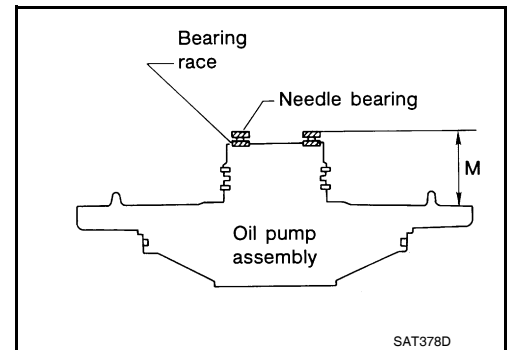

- b. Measure dimension (M).

(M) : Distance between transaxle case fitting surface of oil pump cover and needle bearing on oil pump cover.

(M1) : Indication of gauge

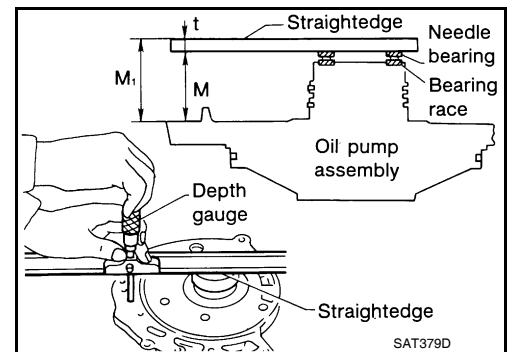

- c. Measure thickness of straightedge (t).

$$M = M_1 - t$$

3. Adjust total end play (T1).

$$T_1 = J - M$$

Total end play (T1):

Refer to [AT-379, "Total End Play"](#).

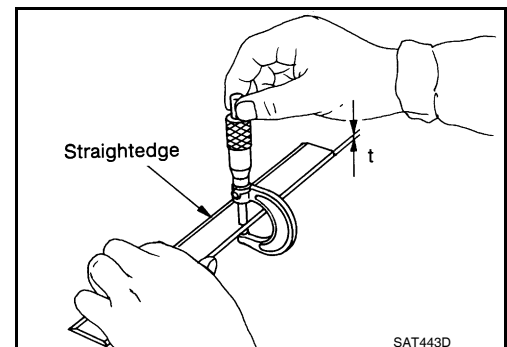

ASSEMBLY

< SERVICE INFORMATION >

- Select proper thickness of bearing race so that total end play is within specifications. Refer to “Parts Information” for bearing race selection.

REVERSE CLUTCH END PLAY

- Measure clearance between oil pump cover and thrust washer for reverse clutch drum.
- Select proper thickness of thrust washer so that end play is within specification.

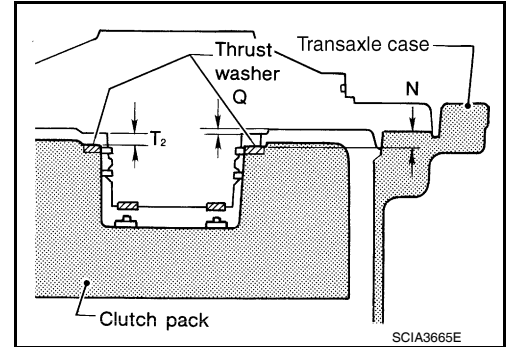

1. Measure dimensions O and P), and then calculate dimension N).

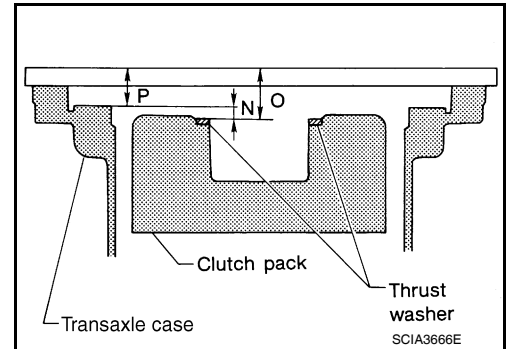

- a. Place thrust washer on reverse clutch drum.
- b. Measure dimension (O).

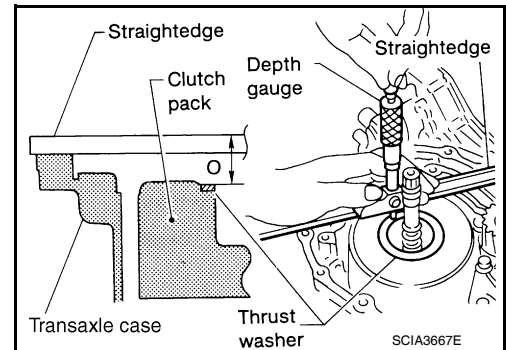

- c. Measure dimension (P).
- d. Calculate dimension (N).

(N) : Distance between oil pump fitting surface of transaxle case and thrust washer on reverse clutch drum.

$$N = O - P$$

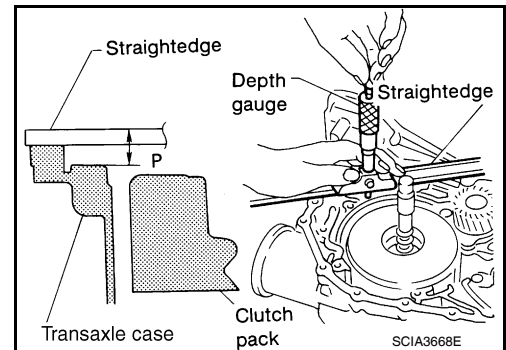

ASSEMBLY

< SERVICE INFORMATION >

2. Measure dimensions (R) and (S), and then calculate dimension (Q).

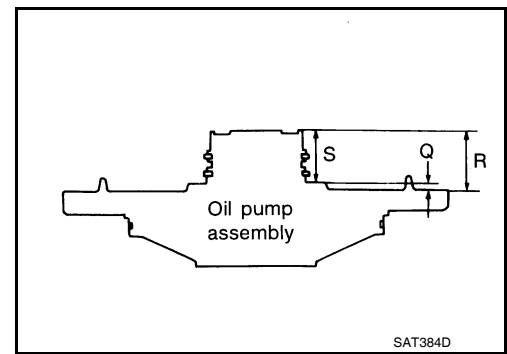

- a. Measure dimension (R).

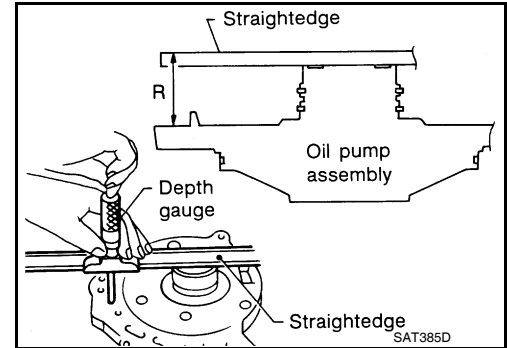

- b. Measure dimension (S).
- c. Calculate dimension (Q).

(Q) : Distance between transaxle case fitting surface and thrust washer mating surface.

$$Q = R - S$$

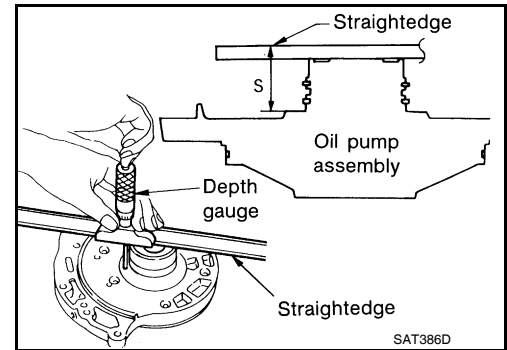

3. Adjust reverse clutch end play (T₂).

$$T_2 = N - Q$$

Reverse clutch end play:

Refer to [AT-379, "Reverse Clutch End Play"](#).

- Select proper thickness of thrust washer so that reverse clutch end play is within specifications. Refer to "Parts Information" for thrust washer selection.

Assembly (3)

INFOID:000000005928308

1. Remove reverse clutch assembly.
2. Install needle bearing on input shaft assembly (high clutch drum).

CAUTION:

Be careful with the direction of needle bearing.

3. Install reverse clutch assembly.

CAUTION:

Align teeth of reverse clutch drive plates before installing.

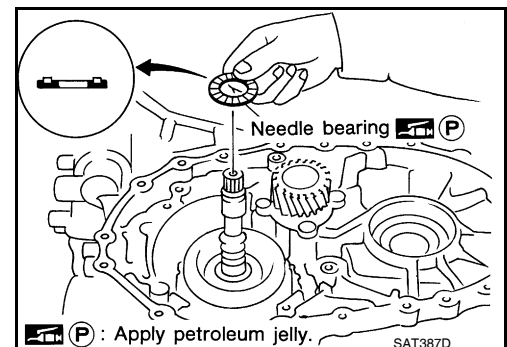

ASSEMBLY

< SERVICE INFORMATION >

4. Install anchor end pin (2) and lock nut (1) on transaxle case.

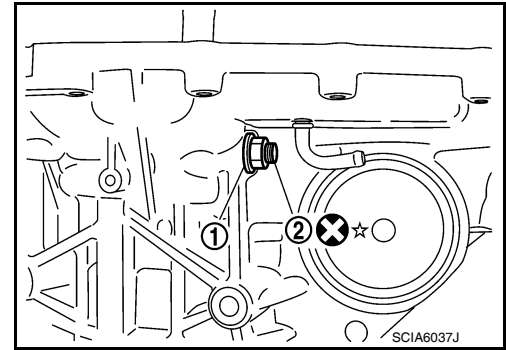

5. Place brake band on outside of reverse clutch drum.
6. Tighten anchor end pin just enough so that brake band is evenly fitted on reverse clutch drum.

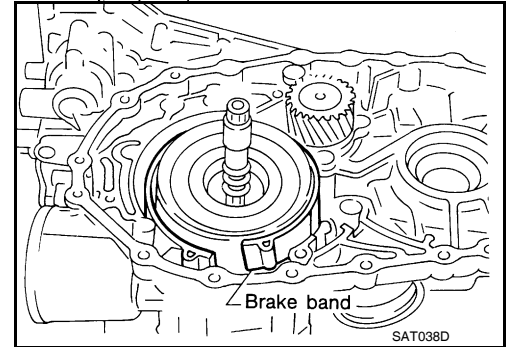

7. Install bearing race selected in total end play adjustment step on oil pump cover.
8. Install thrust washer selected in reverse clutch end play adjustment step on oil pump cover.
9. Install O-ring to oil pump assembly.

CAUTION:

- Do not reuse O-ring.
- Apply ATF to O-ring.

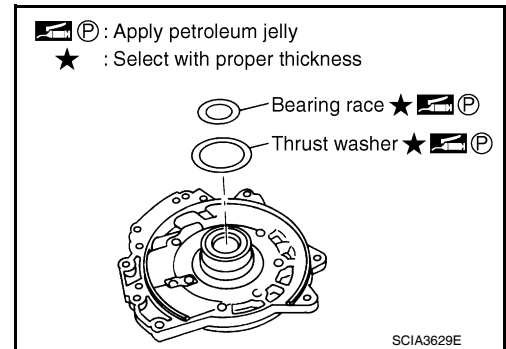

10. Install oil pump assembly (1) on transaxle case.
11. Tighten oil pump bolts to the specified torque. Refer to [AT-237](#), "[Component](#)".

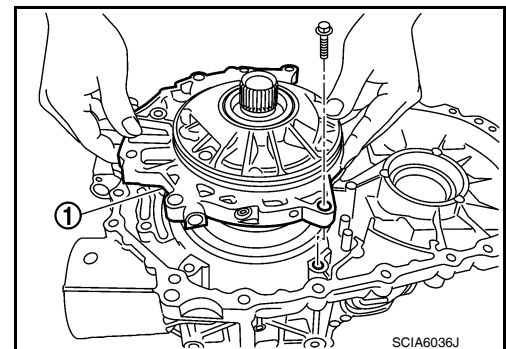

12. Install O-ring to input shaft assembly (high clutch drum).

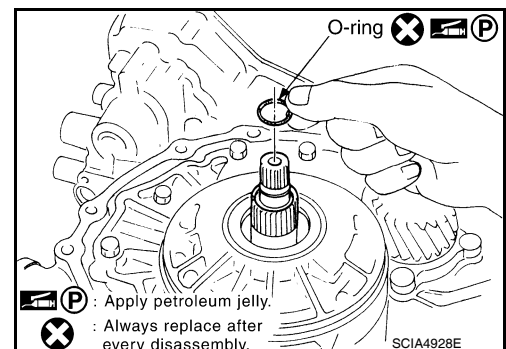

ASSEMBLY

< SERVICE INFORMATION >

13. Adjust brake band.

a. Tighten anchor end pin to the specified torque.

Anchor end pin bolt : 4.9 N·m (0.50 kg-m, 43 in-lb)

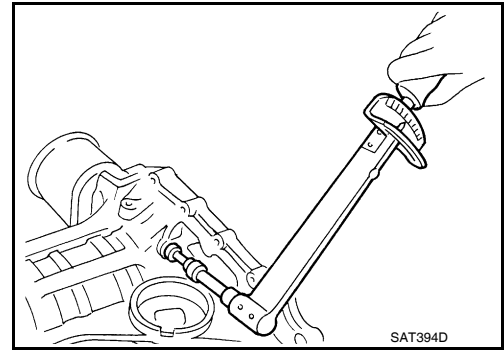

b. Back off anchor end pin two and a half turns.

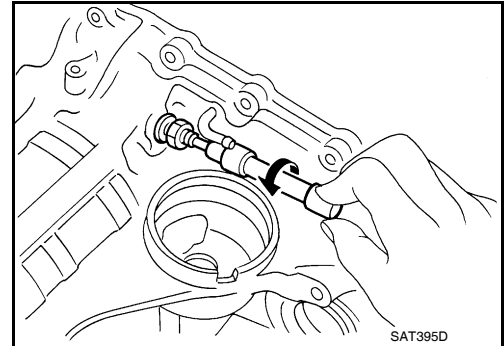

c. Tighten lock nut while holding anchor end pin. Refer to [AT-237, "Component"](#).

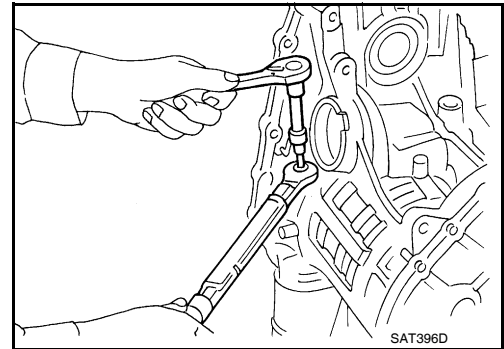

14. Apply compressed air into oil holes of transaxle case and check operation of brake band.

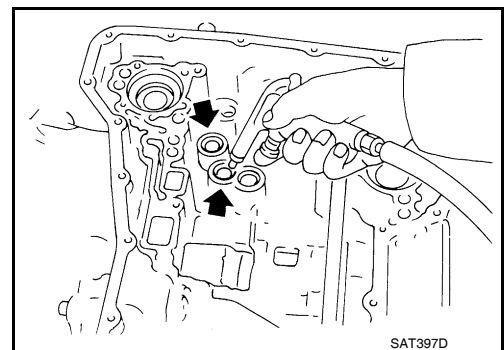

15. Select proper thickness of differential side bearing adjusting shim using the following procedures. (HR16DE engine models)

- Measure differential side bearing end play, and calculate the adjusting shim thickness so that the end play is within the specifications.

Differential side bearing end play : Refer to [AT-379, "Total End Play"](#)

A
B
AT
D
E
F
G
H
I
J
K
L
M
N
O
P

ASSEMBLY

< SERVICE INFORMATION >

- a. Place a straightedge (A) onto transaxle case (1), and measure the depth (T) of transaxle case (1) to the mating surface for differential side bearing using depth gauge (B).
- T = (measurement) - (Straightedge thickness)**
- Measure the T in at least two places, and take the average.

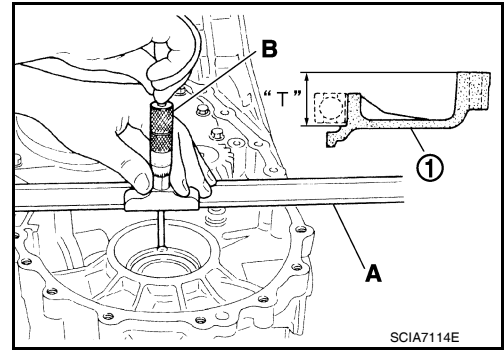

- b. Install final drive assembly onto converter housing(1).
- c. Place straightedge (A) onto differential case (2), and measure the height (U) to the end of the converter housing (1) using depth gauge (B).

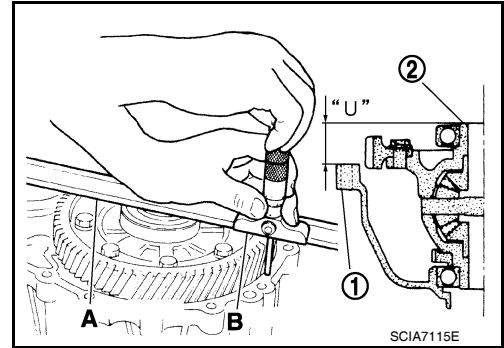

16. Install differential side bearing adjusting shim selected in differential side bearing end play adjustment step to transaxle case. (HR16DE engine models only)

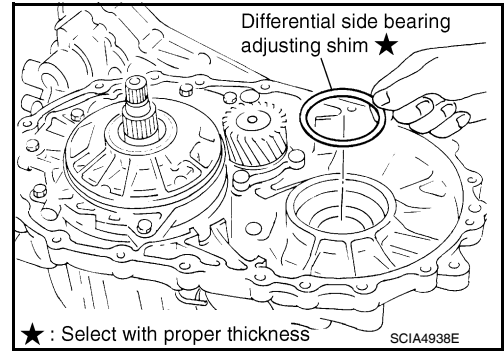

17. Install final drive assembly on transaxle case.

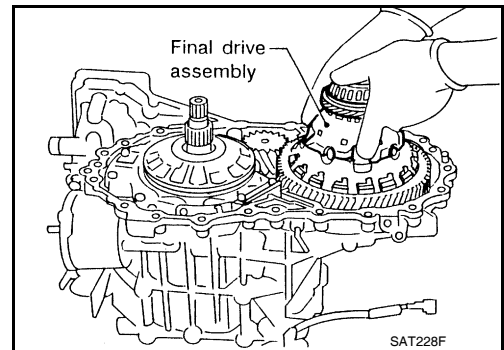

18. Install differential lubricant tube (1) and clips (2) on converter housing.

← Bolt

19. Tighten differential lubricant tube bolts to the specified torque. Refer to [AT-237, "Component"](#).

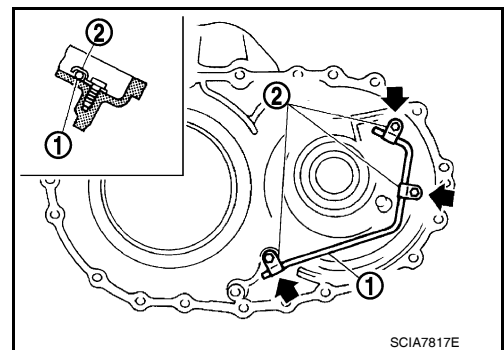

ASSEMBLY

< SERVICE INFORMATION >

20. Install O-ring on differential oil port of transaxle case.

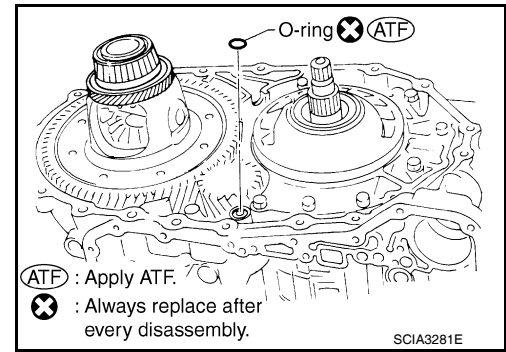

21. Apply recommended (Genuine Anaerobic Liquid Gasket or equivalent) to transaxle case as shown.

⇐: Inside of transaxle case

(A) : 3 - 5 mm (0.12 - 0.20 in)

(B) : 8 mm (0.31 in) R

(C) : 1.5 mm (0.059 in) dia.

(D) : 4 mm (0.16 in)

CAUTION:

Completely remove all moisture, oil and old sealant, etc. from the transaxle case and converter housing mating surfaces.

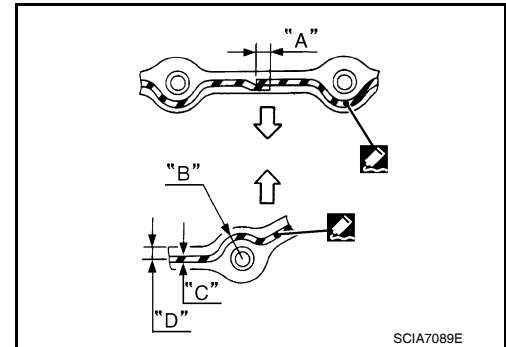

22. Install converter housing on transaxle case.

23. Install bracket on converter housing.

24. Tighten converter housing bolts (1) and (2) to the specified torque. Refer to [AT-237, "Component"](#).

- HR16DE engine models

Bolt	1	2
Bolt length [mm (in)]	30 (1.18)	40 (1.57)
		
Number of bolts	10	10

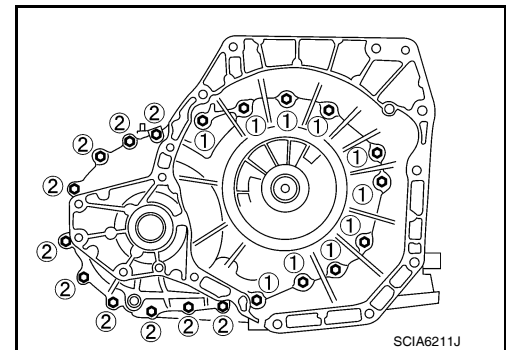

- MR18DE engine models

Bolt	1	2
Bolt length [mm (in)]	32.8 (1.291)	40 (1.57)
		
Number of bolts	10	10

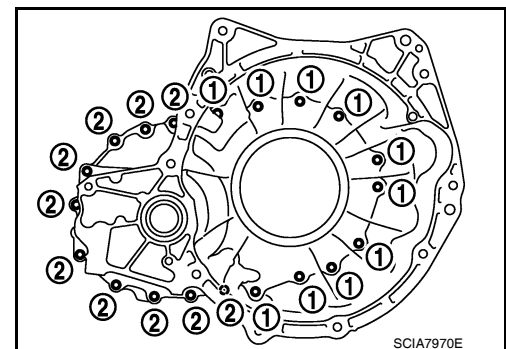

25. Install plug or speedometer pinion according to the following procedures.

ASSEMBLY

< SERVICE INFORMATION >

- a. With ABS
 - i. Install O-ring (3) to plug (1).
 - ii. Install plug (1) to converter housing (2).
←: Bolt

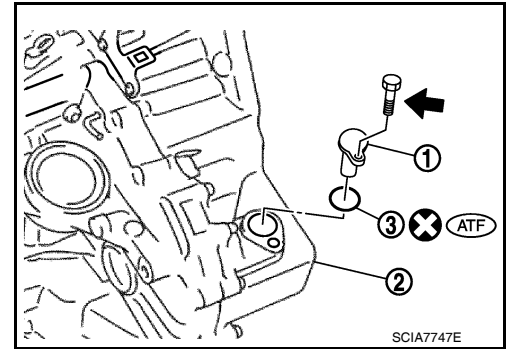

- b. Without ABS
 - i. Install O-ring (3) to speedometer pinion (1).
 - ii. Install speedometer pinion (1) to converter housing (2).
←: Bolt

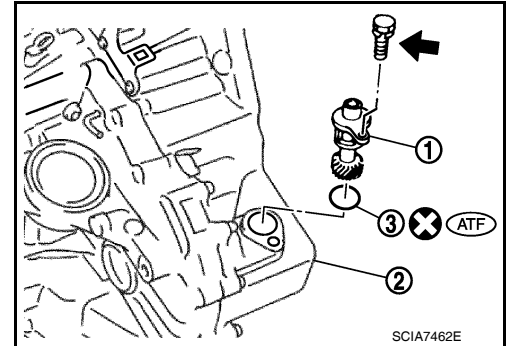

26. Tighten plug or speedometer pinion bolt to the specified torque. Refer to [AT-237, "Component"](#).

27. Install accumulator pistons.

- a. Install O-rings (1) on servo release accumulator piston (2) and N-D accumulator piston (3). Refer to [AT-376, "Accumulator"](#).

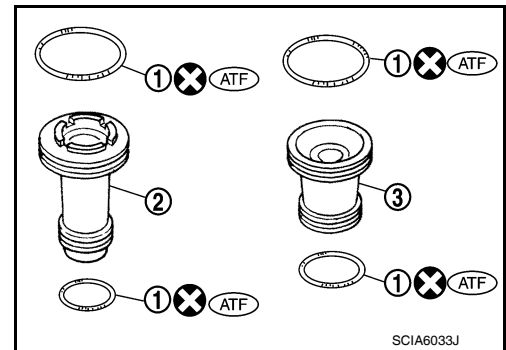

- b. Install return springs (1), servo release accumulator piston (2) and N-D accumulator piston (3) into transaxle case (4). Refer to [AT-376, "Accumulator"](#).

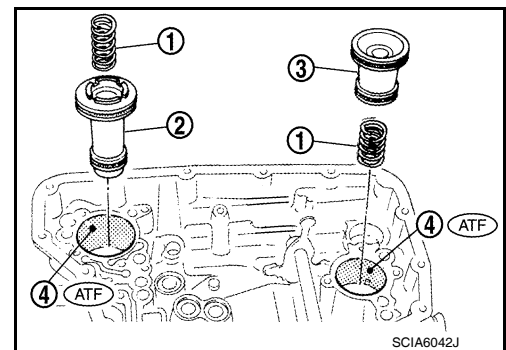

ASSEMBLY

< SERVICE INFORMATION >

28. Install lip seals (1) for band servo oil holes on transaxle case.

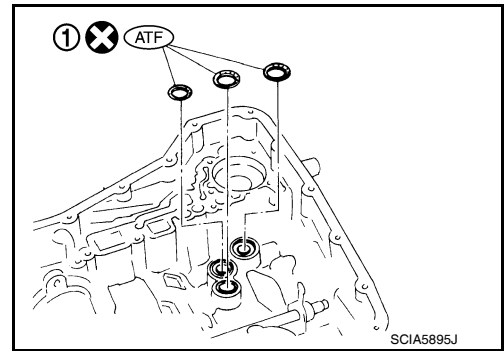

29. Install control valve assembly on transaxle case.

a. Install O-ring on terminal body.

CAUTION:

- Do not reuse O-ring.
- Apply ATF to O-ring.

b. Insert manual valve into control valve assembly.

CAUTION:

Be careful not to drop manual valve.

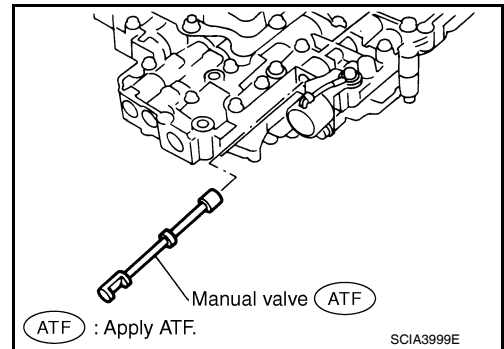

c. Set manual shaft in "N" position.

d. Install control valve assembly on transaxle case while aligning manual valve (2) with manual plate (1).

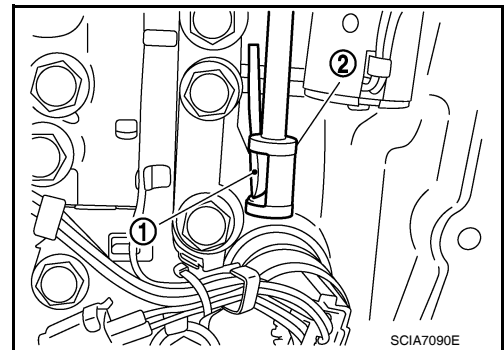

e. Install terminal body (2) into transaxle case by pushing it.

f. Install snap ring (1) to terminal body (2).

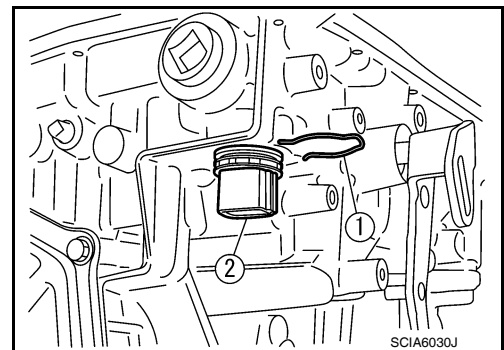

g. Tighten bolts (A), (B) and (C) to the specified torque. Refer to [AT-237. "Component"](#).

ASSEMBLY

< SERVICE INFORMATION >

Bolt length, number and location:

Bolt symbol	A	B	C
Bolt length "ℓ" [mm (in)]	40.0 mm (1.575 in)	33.0 mm (1.299 in)	43.5 mm (1.713 in)
			
Number of bolts	5	6	2

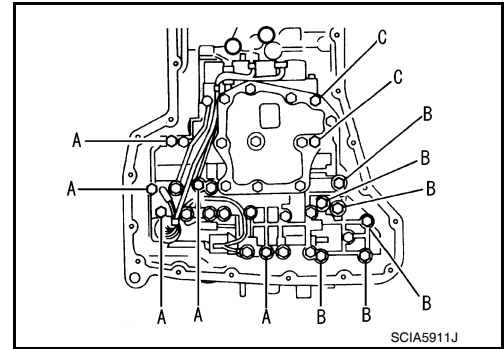

30. Install oil pan.

- a. Attach magnets on oil pan.
- b. Install oil pan gasket on transaxle case.

CAUTION:

- Completely remove all moisture, oil and old gasket, etc. from the oil pan gasket mating surface of transaxle case.
- Do not reuse oil pan gasket.

- c. Install oil pan on transaxle case.

CAUTION:

Completely remove all moisture, oil and old gasket, etc. from the oil pan gasket mating surface of oil pan.

- d. Tighten oil pan bolts (1) to the specified torque. Refer to [AT-237, "Component"](#).
 - HR16DE engine models

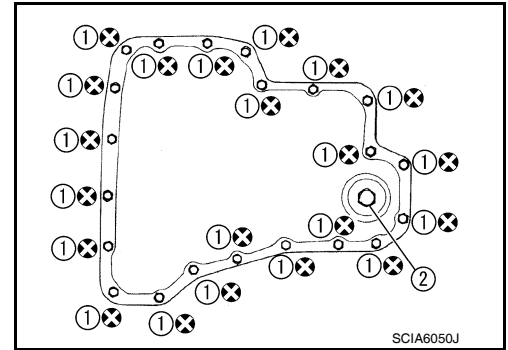

- MR18DE engine models

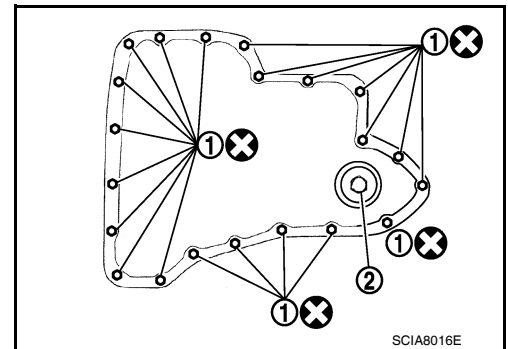

CAUTION:

- Always replace oil pan bolts (1) as they are self-sealing bolts.
- Tighten four bolts in a criss-cross pattern to prevent dislocation of gasket.

- e. Install drain plug gasket and drain plug (2) to oil pan.

CAUTION:

Do not reuse drain plug gasket.

- f. Tighten drain plug to the specified torque. Refer to [AT-237, "Component"](#).

ASSEMBLY

< SERVICE INFORMATION >

31. Install transmission range switch (2) on transaxle case.

←: Bolt

- a. Set manual shaft (1) in "P" position.
 - b. Temporarily install transmission range switch (2) on manual shaft (1).
 - c. Set manual shaft (1) in "N" position.
 - d. Use a 4 mm (0.16 in) dia. pin for this adjustment.
 - i. Insert the pin straight into the manual shaft (1) adjustment hole.
 - ii. Rotate transmission range switch (2) until the pin can also be inserted straight into hole in transmission range switch (2).
- e. Tighten transmission range switch bolts to the specified torque. Refer to [AT-237, "Component"](#).
- f. Remove pin from adjustment hole after adjusting transmission range switch (2).

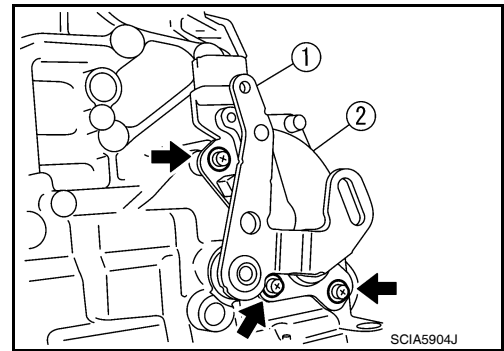

32. Install O-ring (3) to input speed sensor (1).

33. Install input speed sensor (1) to transaxle case (2).

←: Bolt

34. Tighten input speed sensor bolt to the specified torque. Refer to [AT-237, "Component"](#).

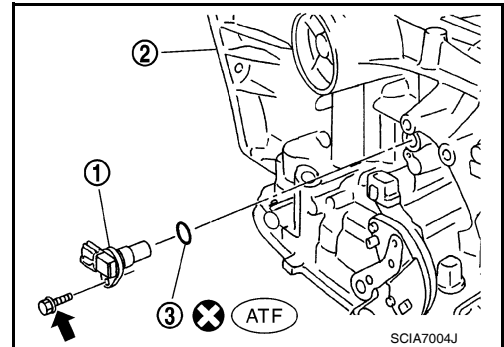

35. Install output speed sensor (1) to transaxle case (2).

36. Tighten output speed sensor bolts to the specified torque. Refer to [AT-237, "Component"](#).

←: Bolt

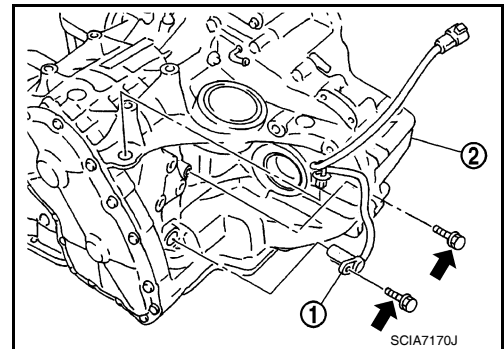

CAUTION:

Ensure output speed sensor harness is firmly secured with bolt.

(1): Output speed sensor

←: Bolt

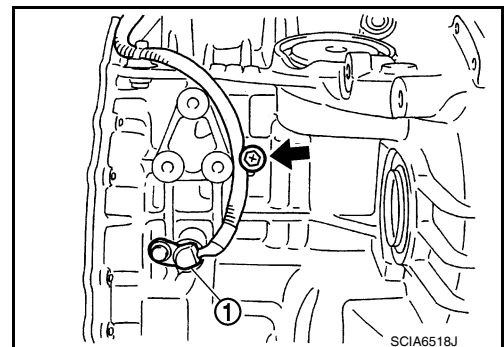

A
B
AT
D
E
F
G
H
I
J
K
L
M
N
O
P

ASSEMBLY

< SERVICE INFORMATION >

37. Install torque converter.

a. Pour ATF into torque converter.

- **Approximately 1 liter (1 US qt, 7/8 Imp pt) of fluid is required for a new torque converter.**
- **When reusing old torque converter, add the same amount of ATF as was drained.**

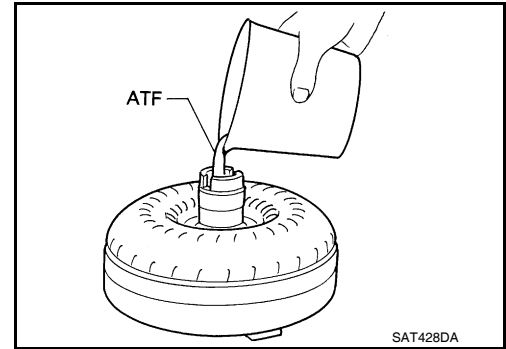

b. Install torque converter while aligning notches of torque converter with notches of oil pump.

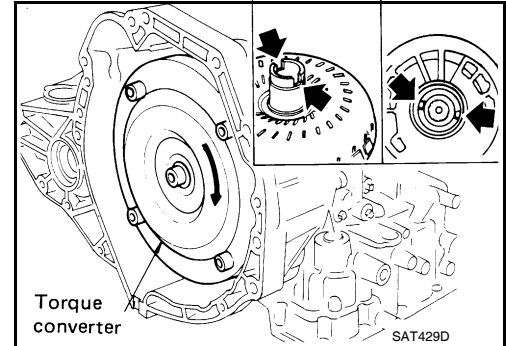

c. Measure distance (A) to make sure that torque converter is in proper position.

Distance (A)

HR16DE models : 16.2 mm (0.638 in) or more

MR18DE models : 14.4 mm (0.567 in) or more

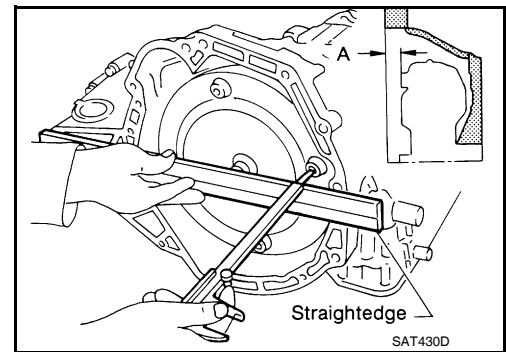

SERVICE DATA AND SPECIFICATIONS (SDS)

< SERVICE INFORMATION >

SERVICE DATA AND SPECIFICATIONS (SDS)

General Specification

INFOID:000000005928309

Engine		HR16DE	MR18DE
Automatic transaxle model		RE4F03B	
Automatic transaxle assembly	Model code number	3CX3D, 3CX3E	3CX0D
Transaxle gear ratio	1st	2.861	
	2nd	1.562	
	3rd	1.000	
	4th	0.697	
	Reverse	2.310	
	Final drive	4.072	
Recommended fluid		Genuine NISSAN Matic S ATF (Continental U.S. and Alaska) or Canada NISSAN Automatic Transmission Fluid*	
Fluid capacity [ℓ (US qt, Imp qt)]		7.7 (8-1/8, 6-3/4)	7.9 (8-3/8, 7)

*: Refer to [MA-14](#).

Vehicle Speed at Which Gear Shifting Occurs

INFOID:000000005928310

HR16DE engine models

Throttle position	Vehicle speed km/h (MPH)					
	D1 → D2	D2 → D3	D3 → D4	D4 → D3	D3 → D2	D2 → D1
Full throttle	49 - 57 (31 - 35)	93 - 101 (58 - 62)	148 - 156 (92 - 96)	144 - 152 (90 - 94)	82 - 90 (51 - 55)	39 - 47 (25 - 29)
Half throttle	35 - 43 (22 - 26)	59 - 67 (37 - 41)	117 - 125 (73 - 77)	59 - 67 (37 - 41)	34 - 42 (22 - 26)	15 - 23 (10 - 14)

MR18DE engine models

Throttle position	Vehicle speed km/h (MPH)					
	D1 → D2	D2 → D3	D3 → D4	D4 → D3	D3 → D2	D2 → D1
Full throttle	51 - 59 (32 - 37)	97 - 105 (60 - 65)	154 - 162 (96 - 101)	150 - 158 (93 - 98)	87 - 95 (54 - 59)	40 - 48 (25 - 30)
Half throttle	34 - 42 (21 - 26)	62 - 70 (39 - 43)	124 - 132 (77 - 82)	69 - 77 (43 - 48)	36 - 44 (22 - 27)	19 - 27 (12 - 17)

- At half throttle, the accelerator opening is 4/8 of the full opening.

Vehicle Speed at When Lock-up Occurs/Releases

INFOID:000000005928311

HR16DE engine models

Throttle position	Selector lever position	Vehicle speed km/h (MPH)	
		Lock-up ON	Lock-up OFF
2.0/8	"D" position	73 - 81 (46 - 50)	49 - 57 (31 - 35)
	"D" position (OD OFF)	86 - 94 (53 - 58)	82 - 90 (51 - 55)

MR18DE engine models

Throttle position	Selector lever position	Vehicle speed km/h (MPH)	
		Lock-up ON	Lock-up OFF
2.0/8	"D" position	86 - 94 (53 - 58)	59 - 67 (37 - 42)
	"D" position (OD OFF)	86 - 94 (53 - 58)	83 - 91 (52 - 57)

SERVICE DATA AND SPECIFICATIONS (SDS)

< SERVICE INFORMATION >

Stall Speed

INFOID:000000005928312

Engine	HR16DE	MR18DE
Stall revolution (rpm)	2,250 - 2,700	2,310 - 2,770

Line Pressure

INFOID:000000005928313

Engine speed	Line pressure kPa (kg/cm ² , psi)	
	“D”, “2” and “1” positions	“R” position
Idle speed	500 (5.1, 73)	778 (7.9, 113)
Stall speed	1,173 (12.0, 170)	1,825 (18.6, 265)

Adjusting shims, Needle Bearings, Thrust Washers and Snap Rings

INFOID:000000005928314

OUTER DIAMETER AND INNER DIAMETER OF NEEDLE BEARINGS

HR16DE Engine Models

Unit: mm (in)

Location	Outer diameter	Inner diameter
A	47.0 (1.850)	32.0 (1.260)
B	35.0 (1.378)	20.1 (0.791)
C	60.0 (2.362)	42.0 (1.654)
D	60.0 (2.362)	45.0 (1.772)
E	47.0 (1.850)	30.0 (1.181)
F	42.6 (1.677)	26.1 (1.028)
G	48.0 (1.890)	33.5 (1.319)
H	59.0 (2.323)	42.1 (1.657)

MR18DE Engine Models

Unit: mm (in)

Location	Outer diameter	Inner diameter
A	47.0 (1.850)	32.0 (1.260)
B	35.0 (1.378)	20.1 (0.791)
C	60.0 (2.362)	42.0 (1.654)
D	60.0 (2.362)	45.0 (1.772)
E	47.0 (1.850)	30.0 (1.181)
F	42.6 (1.677)	26.1 (1.028)
G	48.0 (1.890)	33.5 (1.319)
H	55.0 (2.165)	40.5 (1.594)
I	60.0 (2.362)	40.0 (1.575)

OUTER DIAMETER AND INNER DIAMETER OF THRUST WASHERS

HR16DE Engine Models

Unit: mm (in)

Location	Outer diameter	Inner diameter
I	72.0 (2.835)	55.5 (2.185)
J, K	82.0 (3.228)	59.0 (2.323)
L	78.5 (3.091)	62.4 (2.457)

MR18DE Engine Models

SERVICE DATA AND SPECIFICATIONS (SDS)

< SERVICE INFORMATION >

Unit: mm (in)		
Location	Outer diameter	Inner diameter
J	72.0 (2.835)	55.5 (2.185)
K, L	82.0 (3.228)	59.0 (2.323)
M	78.5 (3.091)	62.4 (2.457)

OUTER DIAMETER AND INNER DIAMETER OF BEARING RACES AND ADJUSTING SHIMS

HR16DE Engine Models

Unit: mm (in)		
Location	Outer diameter	Inner diameter
M	48.0 (1.890)	33.0 (1.299)
N	29.0 (1.142)	25.0 (0.984)
O	34.3 (1.350)	26.1 (1.028)
P	79.5 (3.130)	72.0 (2.835)

MR18DE Engine Models

Unit: mm (in)		
Location	Outer diameter	Inner diameter
N	48.0 (1.890)	33.0 (1.299)
O	34.3 (1.350)	26.1 (1.028)
P	68.0 (2.677)	60.0 (2.632)
Q	72.0 (2.835)	61.0 (2.402)

OUTER DIAMETER OF SNAP RINGS

Unit: mm (in)	
Location	Outer diameter
1	142.0 (5.59)
2	
3	
4	162.3 (6.39)
5	
7	113.0 (4.45)
8	135.4 (5.33)
9	126.0 (4.96)

INNER DIAMETER OF SNAP RINGS

Unit: mm (in)	
Location	Inner diameter
6	32.0 (1.260)
10	63.5 (2.500)

Control Valves

INFOID:000000005928315

CONTROL VALVE SPRINGS

SERVICE DATA AND SPECIFICATIONS (SDS)

< SERVICE INFORMATION >

Unit: mm (in)

Location		spring designation	Free length (l)	Outer diameter (D)
Upper body	L14	Pilot valve spring	38.98 (1.5346)	8.9 (0.350)
	L15	1-2 accumulator valve spring	20.5 (0.807)	6.95 (0.2736)
		1-2 accumulator piston spring	55.66 (2.1913)	19.5 (0.768)
	L16	1st reducing valve spring	27.0 (1.063)	7.0 (0.276)
	L17	3-2 timing valve spring	23.0 (0.906)	6.65 (0.2618)
	L18	Overrun clutch reducing valve spring	37.5 (1.476)	7.0 (0.276)
	L19	Torque converter relief valve spring	33.3 (1.311)	9.0 (0.354)
	L20	Torque converter clutch control valve spring	53.01 (2.0870)	6.5 (0.256)
Lower body	L21	Cooler check valve spring	28.04 (1.1039)	7.15 (0.2815)
	L3	Pressure regulator valve spring	45.0 (1.772)	15.0 (0.591)
	L4	Overrun clutch control valve spring	21.7 (0.854)	7.0 (0.276)
	L5	Accumulator control valve spring	22.0 (0.866)	6.5 (0.256)
	L6	Shift valve A spring	21.7 (0.854)	7.0 (0.276)
	L7	Shuttle valve spring	51.0 (2.008)	5.65 (0.2224)
	L12	Shift valve B spring	21.7 (0.854)	7.0 (0.276)
	L13	Pressure modifier valve spring	32.0 (1.260)	6.9 (0.272)
		Pressure modifier piston spring	30.5 (1.201)	9.8 (0.386)
	—	Line pressure relief valve spring	17.02 (0.6701)	8.0 (0.315)
—	Torque converter pressure holding spring	9.0 (0.354)	7.3 (0.287)	

Accumulator

INFOID:000000005928316

RETURN SPRINGS

Unit: mm (in)

Location	Free length (L1)
Servo release accumulator	62.8 (2.472)

Unit: mm (in)

Location	Length (L2)
N-D accumulator	46.5 (1.831)

O-RINGS

Unit: mm (in)

Location	Inner diameter (Small)	Inner diameter (Large)
Servo release accumulator	26.9 (1.059)	44.2 (1.740)
N-D accumulator	34.6 (1.362)	39.4 (1.551)

Clutches and Brakes

INFOID:000000005928317

REVERSE CLUTCH

Number of drive plates		2
Number of driven plates		2
Drive plate thickness [mm (in)]	Standard	2.0 (0.079)
	Allowable limit	1.8 (0.071)
Driven plate thickness [mm (in)]	Standard	2.0 (0.079)
	Allowable limit	1.2 (0.047)
Clearance [mm (in)]	Standard	0.5 - 0.8 (0.020 - 0.031)
	Allowable limit	1.2 (0.047)

SERVICE DATA AND SPECIFICATIONS (SDS)

< SERVICE INFORMATION >

HIGH CLUTCH

Applied model		HR16DE engine	MR18DE engine	
Number of drive plates		3	4	
Number of driven plates		5	7 (1*1 + 6*2)	
Drive plate thickness [mm (in)]	Standard	1.6 (0.063)	1.6 (0.063)	
	Allowable limit	1.4 (0.055)	1.4 (0.055)	
Driven plate thickness [mm (in)]	Standard	2.0 (0.079)	*1	*2
			2.0 (0.079)	1.5 (0.059)
Clearance [mm (in)]	Standard	1.4 - 1.8 (0.055 - 0.071)	1.4 - 1.8 (0.055 - 0.071)	
	Allowable limit	2.4 (0.094)	2.6 (0.102)	

FORWARD CLUTCH

Number of drive plates		5
Number of driven plates		5
Drive plate thickness [mm (in)]	Standard	1.8 (0.071)
	Allowable limit	1.6 (0.063)
Driven plate thickness [mm (in)]	Standard	2.0 (0.079)
Clearance [mm (in)]	Standard	0.45 - 0.85 (0.0177 - 0.0335)
	Allowable limit	1.85 (0.0728)

OVERRUN CLUTCH

Number of drive plates		3
Number of driven plates		4
Drive plate thickness [mm (in)]	Standard	1.6 (0.063)
	Allowable limit	1.4 (0.055)
Driven plate thickness [mm (in)]	Standard	2.0 (0.079)
Clearance [mm (in)]	Standard	1.0 - 1.4 (0.039 - 0.055)
	Allowable limit	2.0 (0.079)

LOW & REVERSE BRAKE

Applied model		HR16DE engine	MR18DE engine
Number of drive plates		4	5
Number of driven plates		4	5
Drive plate thickness [mm (in)]	Standard	2.0 (0.079)	2.0 (0.079)
	Allowable limit	1.8 (0.071)	1.8 (0.071)
Driven plate thickness [mm (in)]	Standard	2.0 (0.079)	2.0 (0.079)
Clearance [mm (in)]	Standard	1.4 - 1.8 (0.055 - 0.071)	1.4 - 1.8 (0.055 - 0.071)
	Allowable limit	2.6 (0.102)	2.8 (0.110)

BRAKE BAND

Anchor end pin tightening torque [N·m (kg-m, in-lb)]	4.9 (0.50, 43)
Number of returning revolutions for anchor end pin	2.5
Lock nut tightening torque [N·m (kg-m, ft-lb)]	33.9 (3.5, 25)

SERVICE DATA AND SPECIFICATIONS (SDS)

< SERVICE INFORMATION >

Final Drive

INFOID:000000005928318

DIFFERENTIAL SIDE GEAR CLEARANCE

Clearance between side gear and differential case with washer [mm (in)]	0.1 - 0.2 (0.004 - 0.008)
---	---------------------------

DIFFERENTIAL SIDE BEARING END PLAY (FOR HR16DE ENGINE MODELS)

Differential side bearing end play mm (in)	0 - 0.15 (0 - 0.0059)
--	-----------------------

BEARING PRELOAD (FOR MR18DE ENGINE MODELS)

Differential side bearing preload mm (in)	0.05 - 0.09 (0.0020 - 0.0035)
---	-------------------------------

TURNING TORQUE (FOR MR18DE ENGINE MODELS)

Turning torque of final drive assembly N-m (kg-cm, in-lb)	0.68 - 1.26 (7.0 - 13.0, 6.0 - 11.0)
---	--------------------------------------

Planetary Carrier

INFOID:000000005928319

Clearance between planetary carrier and pinion washer [mm (in)]	Standard	0.15 - 0.70 (0.0059 - 0.0276)
	Allowable limit	0.80 (0.0315)

Oil Pump

INFOID:000000005928320

Oil pump side clearance		0.02 - 0.04 (0.0008 - 0.0016)
Clearance between oil pump housing and outer gear [mm (in)]	Standard	0.08 - 0.15 (0.0031 - 0.0059)
	Allowable limit	0.15 (0.0059)
Oil pump cover seal ring clearance [mm (in)]	Standard	0.10 - 0.25 (0.0039 - 0.0098)
	Allowable limit	0.25 (0.0098)

Input Shaft

INFOID:000000005928321

SEAL RING CLEARANCE

Input shaft seal ring clearance [mm (in)]	Standard	0.08 - 0.23 (0.0031 - 0.0091)
	Allowable limit	0.23 (0.091)

SEAL RING

Unit: mm (in)

Outer diameter	Inner diameter	Width
24 (0.94)	20.4 (0.803)	1.97 (0.0776)

Reduction Pinion Gear

INFOID:000000005928322

TURNING TORQUE

Turning torque of reduction pinion gear [N-m (kg-m, in-lb)]	0.11 - 0.69 (0.01 - 0.07, 1 - 6)
---	----------------------------------

Band Servo

INFOID:000000005928323

RETURN SPRINGS

SERVICE DATA AND SPECIFICATIONS (SDS)

< SERVICE INFORMATION >

Unit: mm (in)

Return spring	Free length
2nd servo return spring	32.5 (1.280)
OD servo return spring	38.52 (1.5165)

Output Shaft

INFOID:000000005928324

SEAL RING CLEARANCE

Output shaft seal ring clearance [mm (in)]	Standard	0.10 - 0.25 (0.0039 - 0.0098)
	Allowable limit	0.25 (0.0098)

SEAL RING

Unit: mm (in)

Outer diameter	Inner diameter	Width
29.5 (1.161)	26.2 (1.031)	1.95 (0.0768)

TURNING TORQUE (FOR HR16DE ENGINE MODELS)

Turning torque of output shaft ·m (kg-m, in-lb)	0.25 - 0.88 (0.03 - 0.08, 3 - 7)
---	----------------------------------

END PLAY (FOR MR18DE ENGINE MODELS)

Output shaft end play mm (in)	0 - 0.5 (0 - 0.020)
-------------------------------	---------------------

Bearing Retainer

INFOID:000000005928325

SEAL RING CLEARANCE

Bearing retainer seal ring clearance [mm (in)]	Standard	0.10 - 0.27 (0.0039 - 0.0106)
	Allowable limit	0.27 (0.0106)

Total End Play

INFOID:000000005928326

Total end play [mm (in)]	0.25 - 0.55 (0.0098 - 0.0217)
--------------------------	-------------------------------

Reverse Clutch End Play

INFOID:000000005928327

Reverse clutch end play [mm (in)]	0.65 - 1.0 (0.0256 - 0.039)
-----------------------------------	-----------------------------

Removal and Installation

INFOID:000000005928328

Engine	HR16DE	MR18DE
Distance between end of converter housing and torque converter [mm (in)]	16.2 (0.638)	14.4 (0.567)

Shift Solenoid Valves

INFOID:000000005928329

Gear position	1	2	3	4
Shift solenoid valve A	ON (Closed)	OFF (Open)	OFF (Open)	ON (Closed)
Shift solenoid valve B	ON (Closed)	ON (Closed)	OFF (Open)	OFF (Open)

SERVICE DATA AND SPECIFICATIONS (SDS)

< SERVICE INFORMATION >

Solenoid Valves

INFOID:000000005928330

Solenoid valve designation	Resistance (Approx.)	Terminal
Shift solenoid valve A	20 - 30 Ω	2
Shift solenoid valve B	5 - 20 Ω	1
Overrun clutch solenoid valve	20 - 30 Ω	3
Line pressure solenoid valve	2.5 - 5.0 Ω	4
Torque converter clutch solenoid valve	5 - 20 Ω	5

A/T Fluid Temperature Sensor

INFOID:000000005928331

Remarks: Specification data are reference values.

Condition	Specification (Approx.)	
Cold [20°C (68°F)]	1.5V	2.5 k Ω
↓	↓	↓
Hot [80°C (176°F)]	0.5V	0.3 k Ω

Output Speed Sensor

INFOID:000000005928332

Condition	Judgment standard
When driving at 20 km/h (12 MPH)	150 Hz (Approx.)

Dropping Resistor

INFOID:000000005928333

Resistance	12 Ω (Approx.)
------------	-----------------------

Input Speed Sensor

INFOID:000000005928334

Condition	Judgment standard
When driving at 20 km/h (12 MPH)	360 Hz (Approx.)