

SECTION **WW**

WIPER, WASHER & HORN

A
B
C
D
E
F
G
H
I
J
L
M
N
O
P

CONTENTS

SERVICE INFORMATION 2	
PRECAUTION 2	
Precaution for Supplemental Restraint System (SRS) "AIR BAG" and "SEAT BELT PRE-TENSIONER"2	Adjustment of Wiper Arm Stop Location21
Precaution Necessary for Steering Wheel Rotation After Battery Disconnect2	Removal and Installation of Front Wiper Drive Assembly22
Precaution for Procedure without Cowl Top Cover.....3	Removal and Installation of Front Washer Nozzle...22
PREPARATION 4	Inspection for Washer Nozzle23
Special Service Tool4	Washer Nozzle Adjustment24
FRONT WIPER AND WASHER SYSTEM 5	Washer Tube Layout24
Component Parts and Harness Connector Location5	Removal and Installation of Front Wiper and Washer Switch25
System Description5	Inspection of Front Wiper and Washer Switch Circuit25
CAN Communication System Description7	Removal and Installation of Washer Tank25
Schematic8	Removal and Installation of Front Washer Motor26
Wiring Diagram - WIPER -9	REAR WIPER AND WASHER SYSTEM27
Terminal and Reference Value for BCM 12	Component Parts and Harness Connector Location27
Terminal and Reference Value for IPDM E/R 12	System Description27
How to Proceed with Trouble Diagnosis 12	Wiring Diagram - WIPER -29
Preliminary Check 12	Terminal and Reference Value for BCM31
CONSULT Function (BCM) 12	How to Proceed with Trouble Diagnosis31
CONSULT Function (IPDM E/R) 13	Preliminary Check31
Front Wiper Does Not Operate 14	CONSULT Function (BCM)31
Front Wiper Does Not Return to Stop Position (After Front Wiper Operates for 10 Seconds, They Stop for 20 Seconds, and After Repeating the Operation Five Times, They Become Inoperative) 16	Rear Wiper Does Not Operate31
Only Front Wiper Low Does Not Operate 17	Rear Wiper Stop Position Is Incorrect33
Only Front Wiper High Does Not Operate 18	Only Rear Wiper Does Not Operate34
Only Front Wiper Intermittent Does Not Operate 19	Only Rear Wiper Intermittent Does Not Operate34
Front Wiper Intermittent Operation Switch Position Cannot Be Adjusted20	Wiper Does Not Wipe When Rear Washer Operates34
Wiper Does Not Wipe When Front Washer Operates20	Removal and Installation34
Front Wiper Does Not Stop20	Washer Nozzle Adjustment37
Removal and Installation of Front Wiper Arms20	POWER SOCKET38
	Wiring Diagram - P/SCKT -38
	Removal and Installation38
	HORN40
	Wiring Diagram - HORN -40
	Removal and Installation40



PRECAUTION

< SERVICE INFORMATION >

SERVICE INFORMATION

PRECAUTION

Precaution for Supplemental Restraint System (SRS) "AIR BAG" and "SEAT BELT PRE-TENSIONER"

INFOID:000000007330347

The Supplemental Restraint System such as "AIR BAG" and "SEAT BELT PRE-TENSIONER", used along with a front seat belt, helps to reduce the risk or severity of injury to the driver and front passenger for certain types of collision. This system includes seat belt switch inputs and dual stage front air bag modules. The SRS system uses the seat belt switches to determine the front air bag deployment, and may only deploy one front air bag, depending on the severity of a collision and whether the front occupants are belted or unbelted. Information necessary to service the system safely is included in the SRS and SB section of this Service Manual.

WARNING:

- To avoid rendering the SRS inoperative, which could increase the risk of personal injury or death in the event of a collision which would result in air bag inflation, all maintenance must be performed by an authorized NISSAN/INFINITI dealer.
- Improper maintenance, including incorrect removal and installation of the SRS, can lead to personal injury caused by unintentional activation of the system. For removal of Spiral Cable and Air Bag Module, see the SRS section.
- Do not use electrical test equipment on any circuit related to the SRS unless instructed to in this Service Manual. SRS wiring harnesses can be identified by yellow and/or orange harnesses or harness connectors.

PRECAUTIONS WHEN USING POWER TOOLS (AIR OR ELECTRIC) AND HAMMERS

WARNING:

- When working near the Airbag Diagnosis Sensor Unit or other Airbag System sensors with the Ignition ON or engine running, DO NOT use air or electric power tools or strike near the sensor(s) with a hammer. Heavy vibration could activate the sensor(s) and deploy the air bag(s), possibly causing serious injury.
- When using air or electric power tools or hammers, always switch the Ignition OFF, disconnect the battery, and wait at least 3 minutes before performing any service.

Precaution Necessary for Steering Wheel Rotation After Battery Disconnect

INFOID:000000007330348

NOTE:

- This Procedure is applied only to models with Intelligent Key system and NATS (NISSAN ANTI-THEFT SYSTEM).
- Remove and install all control units after disconnecting both battery cables with the ignition knob in the "LOCK" position.
- Always use CONSULT to perform self-diagnosis as a part of each function inspection after finishing work. If DTC is detected, perform trouble diagnosis according to self-diagnostic results.

For models equipped with the Intelligent Key system and NATS, an electrically controlled steering lock mechanism is adopted on the key cylinder.

For this reason, if the battery is disconnected or if the battery is discharged, the steering wheel will lock and steering wheel rotation will become impossible.

If steering wheel rotation is required when battery power is interrupted, follow the procedure below before starting the repair operation.

OPERATION PROCEDURE

1. Connect both battery cables.

NOTE:

Supply power using jumper cables if battery is discharged.

2. Use the Intelligent Key or mechanical key to turn the ignition switch to the "ACC" position. At this time, the steering lock will be released.
3. Disconnect both battery cables. The steering lock will remain released and the steering wheel can be rotated.
4. Perform the necessary repair operation.

PRECAUTION

< SERVICE INFORMATION >

5. When the repair work is completed, return the ignition switch to the "LOCK" position before connecting the battery cables. (At this time, the steering lock mechanism will engage.)
6. Perform a self-diagnosis check of all control units using CONSULT.

Precaution for Procedure without Cowl Top Cover

INFOID:000000007330349

When performing the procedure after removing cowl top cover, cover the lower end of windshield with urethane, etc.

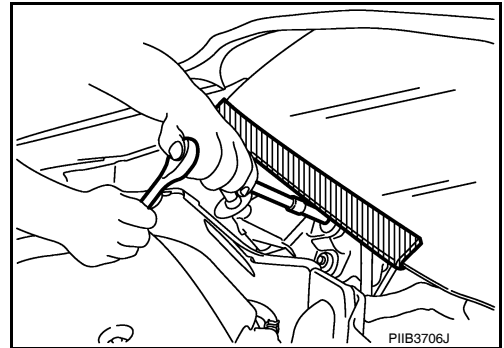

A
B
C
D
E
F
G
H
I
J
L
M
N
O
P

WW

PREPARATION

< SERVICE INFORMATION >

PREPARATION

Special Service Tool

INFOID:000000007330350

The actual shapes of Kent-Moore tools may differ from those of special service tools illustrated here.

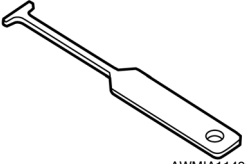
Tool number (Kent-Moore No.) Tool name	Description
<p>— (J-42059) Power socket removal tool</p>  <p>AWMIA1148GB</p>	For removing power sockets

FRONT WIPER AND WASHER SYSTEM

< SERVICE INFORMATION >

FRONT WIPER AND WASHER SYSTEM

Component Parts and Harness Connector Location

INFOID:000000007330351

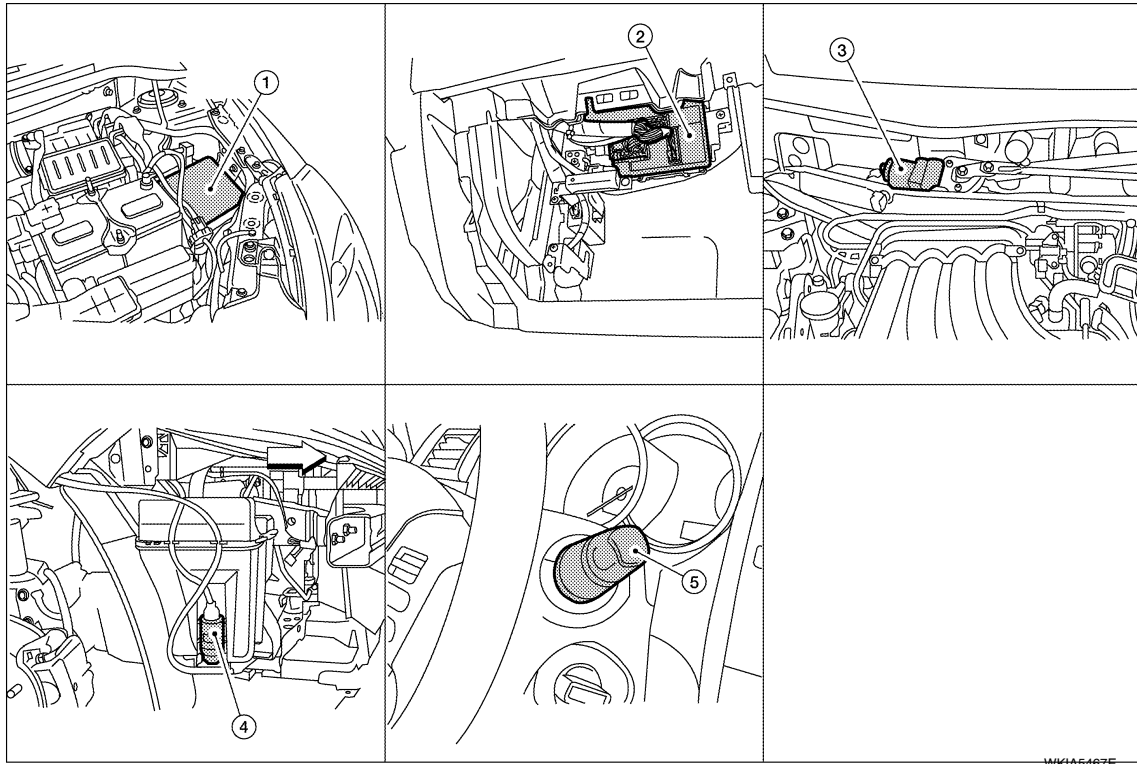

WKIA5467E

- | | | |
|---|--|--|
| 1. IPDM E/R E45, E46 and E48 | 2. BCM M18 and M20 (view with glove box removed) | 3. Front wiper motor E1 (view with cowl top cover removed) |
| 4. Front and rear washer motor E2 (view with front bumper fascia removed) | 5. Combination switch (wiper switch) M28 | ↵: Front |

System Description

INFOID:000000007330352

- Front wiper relays (front wiper relay, front wiper high relay) are located in the IPDM E/R (intelligent power distribution module engine room).
- Combination switch (wiper switch) is composed of a combination of 5 output terminals and 5 input terminals. Terminal combination status is read by BCM (body control module) when switch is turned ON.
- BCM controls front wiper LO, HI, and INT (intermittent) operation.
- IPDM E/R operates wiper motor according to CAN communication signals from BCM.

OUTLINE

Power is supplied at all times

- to ignition relay, located in IPDM E/R, from battery directly,
- through 40A fusible link (letter **g**, located in fuse and fusible link box)
- to BCM terminal 70,
- through 30A fuse (No. 39, located in IPDM E/R)
- to front wiper relay located in IPDM E/R
- through 15A fuse (No. 52, located in IPDM E/R), and
- through 20A fuse (No. 53, located in IPDM E/R)
- to CPU located in IPDM E/R.

When ignition switch is in ON or START position, power is supplied

- through ignition relay (located in IPDM E/R)
- to front wiper relay (located in IPDM E/R), and

A
B
C
D
E
F
G
H
I
J

WW

L
M
N
O
P

FRONT WIPER AND WASHER SYSTEM

< SERVICE INFORMATION >

- to front wiper high relay (located in IPDM E/R), and
- to CPU (located in IPDM E/R),
- through 10A fuse [No. 6, located in fuse block (J/B)]
- to BCM terminal 38,
- through 15A fuse [No. 4, located in fuse block (J/B)]
- to combination switch (wiper switch) terminal 14.

Ground is supplied

- to IPDM E/R terminals 39 and 59, and
- to front wiper motor terminal 2
- through grounds E15 and E24
- to BCM terminal 67, and
- to combination switch (wiper switch) terminal 12
- through grounds M57 and M61.

LOW SPEED WIPER OPERATION

When the front combination switch (wiper switch) is in LO position, the BCM detects the low speed wiper ON signal by means of the BCM combination switch (wiper switch) reading function.

The BCM sends a front wiper request signal (LO) through the CAN communication line

- from BCM terminals 39 and 40
- to IPDM E/R terminals 40 and 41.

When the IPDM E/R receives front wiper request signal (LO), it turns ON front wiper relay, located in IPDM E/R, power is supplied

- through IPDM E/R terminal 33 and front wiper high relay and front wiper relay
- to front wiper motor terminal 3.

Ground is supplied

- to front wiper motor terminal 2
- through grounds E15 and E24.

With power and ground is supplied, front wiper motor operates at low speed.

HIGH SPEED WIPER OPERATION

When the front combination switch (wiper switch) is in HI position, the BCM detects a high speed wiper ON signal by means of the BCM combination switch (wiper switch) reading function.

The BCM sends a front wiper request signal (HI) through the CAN communication line

- from BCM terminals 39 and 40
- to IPDM E/R terminals 40 and 41.

When the IPDM E/R receives front wiper request signal (HI), it turns ON front wiper relay and front wiper high relay, located in IPDM E/R, power is supplied

- through IPDM E/R terminal 32
- to front wiper motor terminal 5.

Ground is supplied

- to front wiper motor terminal 2
- through grounds E15 and E24.

With power and ground is supplied, front wiper motor operates at high speed.

INTERMITTENT OPERATION

Wiper intermittent operation delay interval is determined from the intermittent wiper dial position inputs. During each intermittent operation delay interval, the BCM sends a front wiper request signal to the IPDM E/R to operate the wipers.

When the ignition switch is in the ON or START position, and the front combination switch (wiper switch) is turned to the intermittent position, the BCM detects a front wiper (intermittent) ON signal by means of the BCM combination switch (wiper switch) reading function.

BCM then sends front wiper (intermittent) request signal through the CAN communication lines

- from BCM terminals 39 and 40
- to IPDM E/R terminals 40 and 41.

When BCM determines that combination switch (wiper switch) status is front wiper intermittent ON, it performs the following operations.

- BCM detects ON/OFF status of intermittent wiper dial position
- BCM calculates operation interval from wiper dial position.
- BCM sends a front wiper request signal (INT) to IPDM E/R at calculated operation interval.

When IPDM E/R receives the front wiper request signal (INT), it supplies ground to energize the front wiper relay. It then sends auto-stop signal to the BCM and conducts intermittent front wiper motor operation.

FRONT WIPER AND WASHER SYSTEM

< SERVICE INFORMATION >

AUTO STOP OPERATION

With combination switch (wiper switch) turned OFF, wiper motor will continue to operate until wiper arms reach windshield base.

When the wiper arms are not located at base of windshield with combination switch (wiper switch) OFF, ground is supplied

- from IPDM E/R terminal 33
- to front wiper motor terminal 3, in order to continue wiper motor operation at low speed.

When the wiper arms reach base of windshield, front wiper motor terminals 4 and 2 are connected, and ground is supplied

- to IPDM E/R terminal 38
- through front wiper motor terminals 4 and 2, and
- through grounds E15 and E24.

Then the IPDM E/R sends auto stop operation signal to BCM with CAN communication line.

When the BCM receives auto-stop operation signal, BCM sends wiper stop signal to IPDM E/R with CAN communication line.

IPDM E/R stops wiper motor. Wiper motor will then stop wiper arms at the STOP position.

WASHER OPERATION

When the combination switch (wiper switch) is in front wiper washer position, BCM detect front wiper washer signal by BCM combination switch (wiper switch) reading function. Refer to [BCS-4, "System Description"](#) .

Combination switch (wiper switch) power is supplied

- through combination switch (wiper switch) terminal 14
- to washer motor terminal 1.

Ground is supplied

- to front washer motor terminal 2
- through combination switch (wiper switch) terminal 11, and
- through combination switch (wiper switch) terminal 12
- through grounds M57 and M61.

With ground supplied, front washer motor is operated.

When the BCM detects that front washer motor has operated for 0.4 seconds or longer, BCM operates front wiper motor for low speed.

When the BCM detects washer switch is OFF, low speed operation cycles approximately 2 times and stops.

MIST OPERATION

When the combination switch (wiper switch) is turned to the mist position, wiper low speed operation cycles once and then stops.

For additional information about wiper operation under this condition, refer to "LOW SPEED WIPER OPERATION" .

If switch is held in mist position, low speed operation continues.

FAIL-SAFE FUNCTION

If an abnormality occurs in CAN communications, IPDM E/R holds the condition just before fail-safe status is initiated until ignition switch is turned OFF. (If wipers were operating in LO just before the initiation of fail-safe status, they continue to operate in LO until ignition switch is turned OFF.)

COMBINATION SWITCH (WIPER SWITCH) READING FUNCTION

Refer to [BCS-4, "System Description"](#) .

CAN Communication System Description

INFOID:000000007330353

Refer to [LAN-5, "System Description"](#).

FRONT WIPER AND WASHER SYSTEM

< SERVICE INFORMATION >

WW-WIPER-02

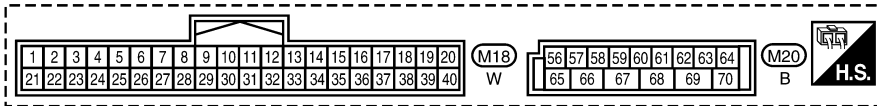
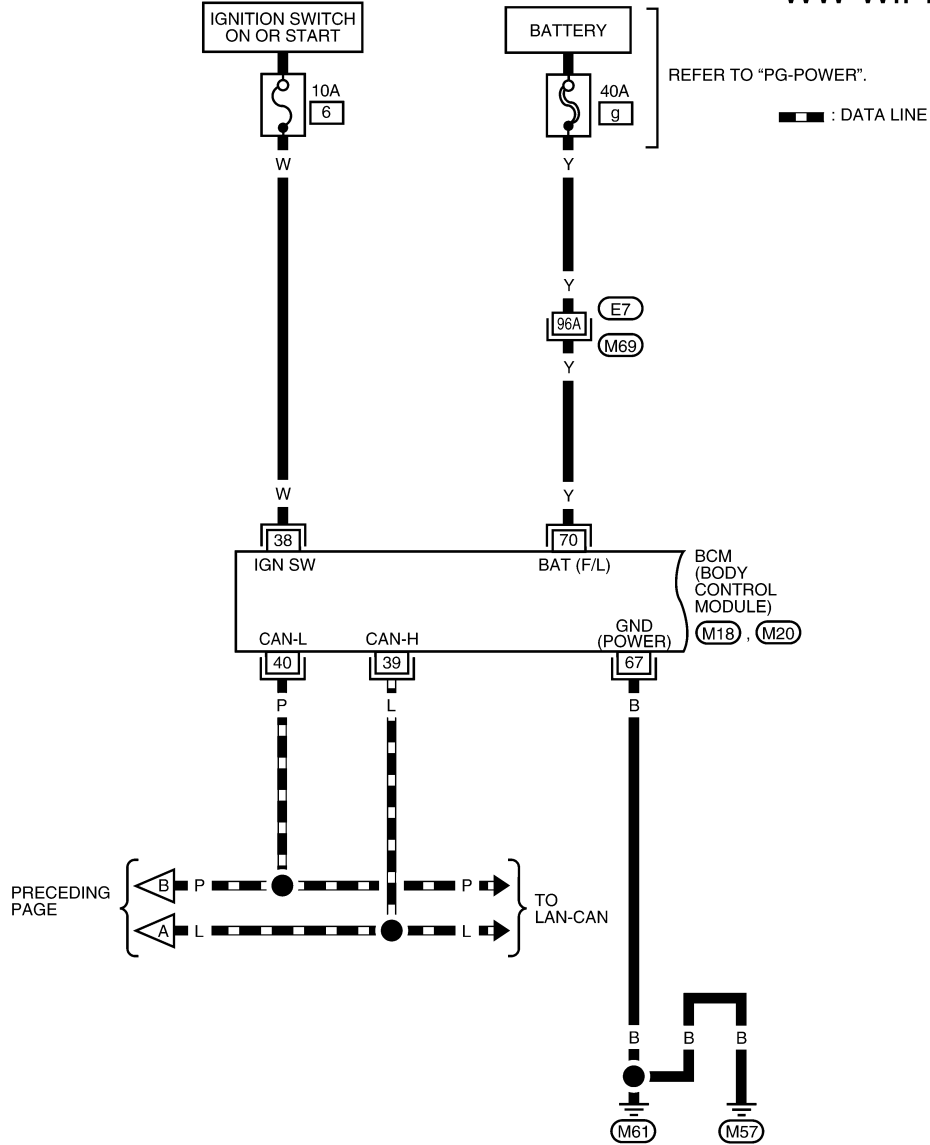

REFER TO THE FOLLOWING.
 (M69) - SUPER MULTIPLE JUNCTION (SMJ)

ABLWA1006GB

FRONT WIPER AND WASHER SYSTEM

< SERVICE INFORMATION >

WW-WIPER-03

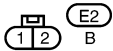
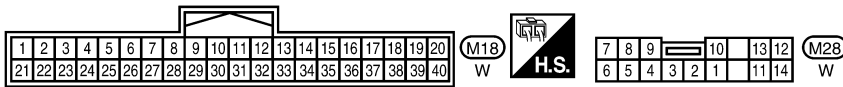
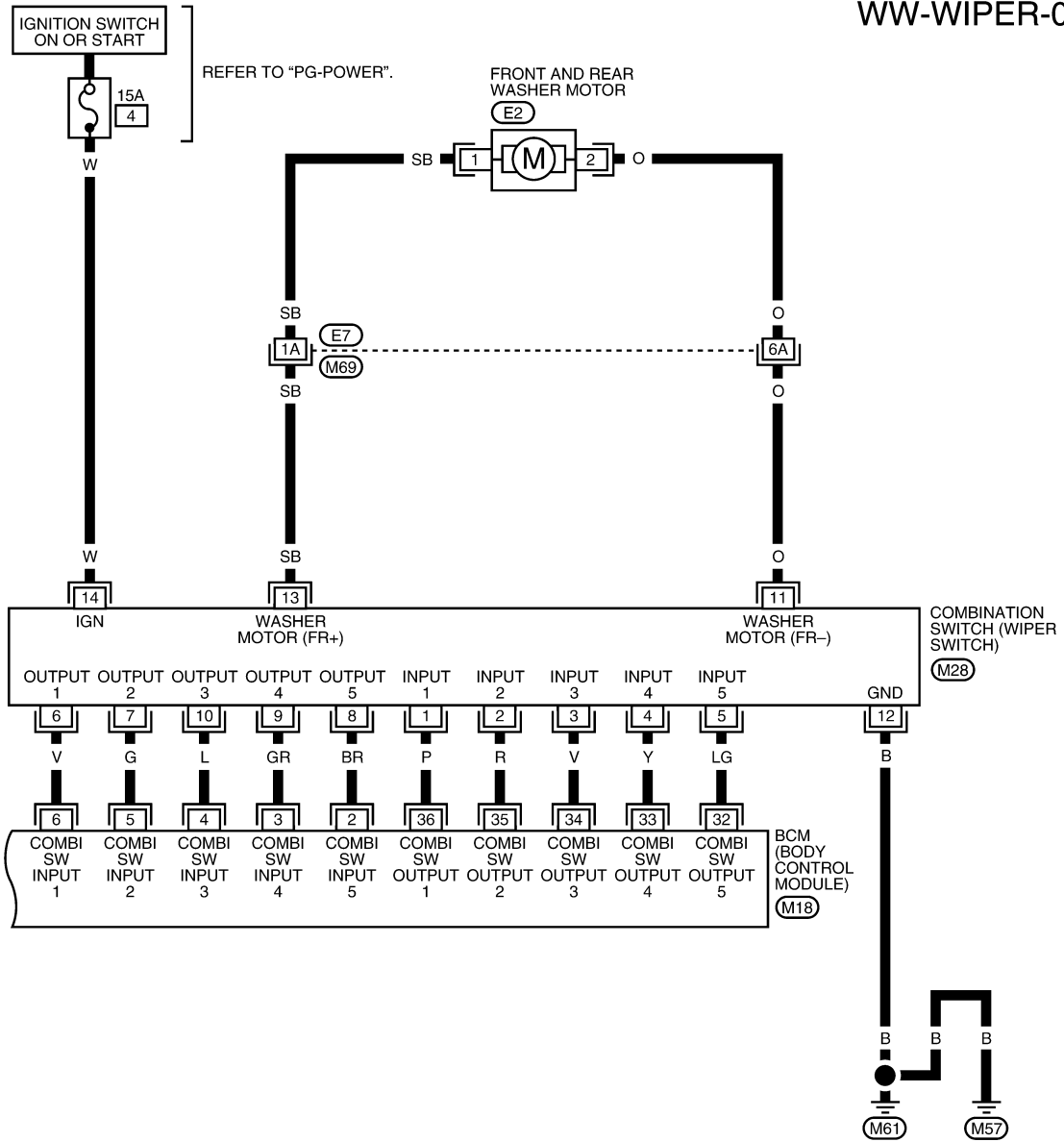

REFER TO THE FOLLOWING.

(M69) - SUPER MULTIPLE JUNCTION (SMJ)

ABLWA1007GB

A
B
C
D
E
F
G
H
I
J
L
M
N
O
P

WW

FRONT WIPER AND WASHER SYSTEM

< SERVICE INFORMATION >

Terminal and Reference Value for BCM

INFOID:000000007330356

Refer to [BCS-12, "Terminal and Reference Value for BCM"](#) .

Terminal and Reference Value for IPDM E/R

INFOID:000000007330357

Refer to [PG-24, "Terminal and Reference Value for IPDM E/R"](#) .

How to Proceed with Trouble Diagnosis

INFOID:000000007330358

1. Confirm symptoms and customer complaint.
2. Understand operation description and function description. Refer to [WW-5, "System Description"](#) .
3. Perform preliminary check. Refer to [WW-12, "Preliminary Check"](#) .
4. Check symptom and repair or replace malfunctioning parts.
5. Does front wiper and washer operate normally? If YES, GO TO 6. If NO, GO TO 4.
6. Inspection End.

Preliminary Check

INFOID:000000007330359

CHECK POWER SUPPLY AND GROUND CIRCUIT FOR BCM

Refer to [BCS-16, "BCM Power Supply and Ground Circuit Inspection"](#)

CONSULT Function (BCM)

INFOID:000000007330360

CONSULT can display each diagnostic item using the diagnostic test modes shown following.

BCM diagnosis position	Diagnosis mode	Description
WIPER	WORK SUPPORT	Changes the setting for each function.
	DATA MONITOR	Displays BCM input data in real time.
	ACTIVE TEST	Device operation can be checked by applying a drive signal to device.
BCM	SELF DIAGNOSTIC RESULT	BCM performs self-diagnosis of CAN communication.
	CAN DIAG SUPPORT MNTR	The result of transmit/receive diagnosis of CAN communication can be read.

WORK SUPPORT

Display Item List

Item	Description	CONSULT	Factory setting
WIPER SPEED SETTING	Vehicle speed sensing type wiper control mode can be changed in this mode.	ON	—
		OFF	x

DATA MONITOR

ALL SIGNALS	Monitors all the signals.
SELECTION FROM MENU	Selects items and monitor them.

Display Item List

Monitor item	Contents
IGN ON SW "ON/OFF"	Displays "ignition switch ON (ON)/Other OFF or ACC (OFF)" status as judged from ignition switch signal.
IGN SW CAN "ON/OFF"	Displays "ignition switch ON (ON)/Other OFF or ACC (OFF)" status as judged from CAN communication signal.
FR WIPER HI "ON/OFF"	Displays "FRONT WIPER HI (ON)/Other (OFF)" status as judged from combination switch (wiper switch) signal.

FRONT WIPER AND WASHER SYSTEM

< SERVICE INFORMATION >

Monitor item	Contents
FR WIPER LOW "ON/OFF"	Displays "FRONT WIPER LOW (ON)/Other (OFF)" status as judged from combination switch (wiper switch) signal.
FR WIPER INT "ON/OFF"	Displays "FRONT WIPER INT (ON)/Other (OFF)" status as judged from combination switch (wiper switch) signal.
FR WASHER SW "ON/OFF"	Displays "FRONT WASHER Switch (ON)/Other (OFF)" status as judged from combination switch (wiper switch) signal.
INT VOLUME "1 - 7"	Displays intermittent operation dial position setting (1 - 7) as judged from combination switch (wiper switch) signal.
FR WIPER STOP "ON/OFF"	Displays "Stopped (ON)/Operating (OFF)" status as judged from auto-stop signal.
VEHICLE SPEED "km/h"	Displays vehicle speed status as judged from vehicle speed signal.
RR WIPER ON "ON/OFF"	Displays "REAR WIPER (ON)/Other (OFF)" status as judged from combination switch (wiper switch) signal.
RR WIPER INT "ON/OFF"	Displays "REAR WIPER INT (ON)/Other (OFF)" status as judged from combination switch (wiper switch) signal.
RR WASHER SW "ON/OFF"	Displays "FRONT WASHER Switch (ON)/Other (OFF)" status as judged from combination switch (wiper switch) signal.
RR WIPER STOP "ON/OFF"	Displays "Stopped (ON)/Operating (OFF)" status as judged from auto-stop switch 1.
RR WIPER STP2 "ON/OFF"	Displays "Stopped (ON)/Operating (OFF)" status as judged from auto-stop switch 2.

ACTIVE TEST

Display Item List

Test item	Display on CONSULT screen	Description
Front wiper output	FR WIPER	Operates front wiper in (INT), (LO), or (HI).
Rear wiper output	RR WIPER	Operates rear wiper in (ON) or (OFF)

CONSULT Function (IPDM E/R)

INFOID:000000007330361

CONSULT can display each diagnostic item using the diagnostic test modes shown following.

IPDM E/R diagnostic Mode	Description
SELF DIAGNOSTIC RESULT	Displays IPDM E/R self-diagnosis results.
DATA MONITOR	Displays IPDM E/R input/output data in real time.
CAN DIAG SUPPORT MNTR	The result of transmit/receive diagnosis of CAN communication can be read.
ACTIVE TEST	Operation of electrical loads can be checked by sending drive signal to them.

DATA MONITOR

ALL SIGNALS	Monitors all items.
MAIN SIGNALS	Monitor the predetermined item.
SELECTION FROM MENU	Selects items and monitors them.

All Signals, Main Signals, Selection From Menu

Item name	CONSULT screen display	Display or unit	Monitor item selection			Description
			ALL SIGNALS	MAIN SIGNALS	SELECTION FROM MENU	
FR wiper request	FR WIP REQ	STOP/1LOW/LOW/HI	×	×	×	Signal status input from BCM
Wiper auto stop	WIP AUTO STOP	ACT P/STOP P	×	×	×	Output status of IPDM E/R
Wiper protection	WIP PROT	OFF/BLOCK	×	×	×	Control status of IPDM E/R

NOTE:

FRONT WIPER AND WASHER SYSTEM

< SERVICE INFORMATION >

Perform monitoring of IPDM E/R data with ignition switch ON. When ignition switch is at ACC, the display may not be correct.

ACTIVE TEST

Test item	CONSULT screen display	Description
Front wiper (HI, LO) output	FRONT WIPER	With a certain operation (OFF, HI ON, LO ON), front wiper relay (Lo, Hi) can be operated.

Front Wiper Does Not Operate

INFOID:000000007330362

CAUTION:

- During IPDM E/R fail-safe control, front wipers may not operate. Refer to [PG-17, "System Description"](#) in "PG IPDM E/R" to make sure that it is not in fail-safe status.

1. ACTIVE TEST

With CONSULT

1. Select "IPDM E/R" on CONSULT, and select "ACTIVE TEST" on "SELECT DIAG MODE" screen.
2. Select "FRONT WIPER" on "SELECT TEST ITEM" screen.
3. Touch "LO" or "HI" screen.

Without CONSULT

Start up auto active test. Refer to [PG-20, "Auto Active Test"](#).

Does front wiper operate normally?

- YES >> GO TO 2.
NO >> GO TO 4.

2. CHECK CIRCUIT BETWEEN COMBINATION SWITCH (WIPER SWITCH) AND BCM

With CONSULT

1. Select "BCM" on CONSULT, and select "WIPER" on "SELECT TEST ITEM" screen.
2. Select "DATA MONITOR" on "SELECT DIAG MODE" screen. Make sure that "FR WIPER INT", "FR WIPER LOW", and "FR WIPER HI" turn ON-OFF according to combination switch (wiper switch) operation.

Without CONSULT

Refer to [LT-65, "Combination Switch Inspection"](#).

OK or NG

- OK >> GO TO 3.
NG >> Check combination switch (wiper switch). Refer to [LT-65, "Combination Switch Inspection"](#).

3. CHECK CIRCUIT BETWEEN IPDM E/R AND BCM

Select "BCM" on CONSULT, and perform self-diagnosis for "BCM".

Displayed self-diagnosis results

- NO DTC>>Replace BCM. Refer to [BCS-19, "Removal and Installation of BCM"](#).
CAN COMM CIRCUIT>>Check CAN communication line of BCM. Refer to [BCS-18, "CAN Communication Inspection Using CONSULT \(Self-Diagnosis\)"](#).

4. CHECK GROUND CIRCUIT

1. Turn ignition switch OFF.
2. Disconnect front wiper motor.

FRONT WIPER AND WASHER SYSTEM

< SERVICE INFORMATION >

- Check continuity between front wiper motor connector and ground.

Front wiper motor connector	Terminal	Ground	Continuity
E1	2		Yes

OK or NG

- OK >> GO TO 5.
 NG >> Repair or replace harness.

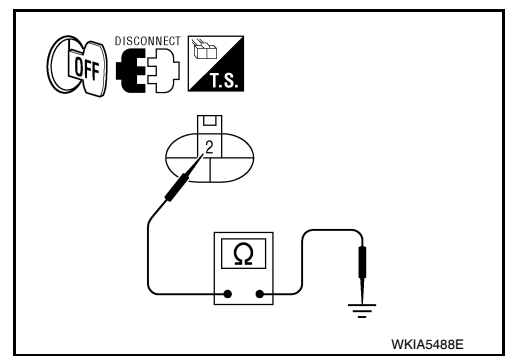

5. CHECK FRONT WIPER CIRCUIT

- Disconnect IPDM E/R.
- Check continuity between IPDM E/R connector (A) and front wiper motor connector (B).

A		B		Continuity
Connector	Terminal	Connector	Terminal	
E45	32	E1	5	Yes
	33		3	

- Check continuity between IPDM E/R connector (A) and ground.

A		Ground	Continuity
Connector	Terminal		
E45	32	No	
	33		

OK or NG

- OK >> GO TO 6.
 NG >> Repair or replace harness.

6. CHECK IPDM E/R

With CONSULT

- Connect IPDM E/R.
- Turn ignition switch ON.
- Select "IPDM E/R" by CONSULT, and select "ACTIVE TEST" on "SELECT DIAG MODE" screen.
- Select "FRONT WIPER" on "SELECT TEST ITEM" screen.
- Touch "LO" or "HI" screen.
- Check voltage between IPDM E/R connector and ground while front wiper (HI, LO) is operating.

Terminal (+)		Terminal (-)	Condition	Voltage (Approx.)
IPDM E/R connector	Terminal			
E45	33	Ground	Stopped	0V
			LO operation	Battery voltage
	32		Stopped	0V
			HI operation	Battery voltage

Without CONSULT

- Connect IPDM E/R.
- Turn ignition switch ON.

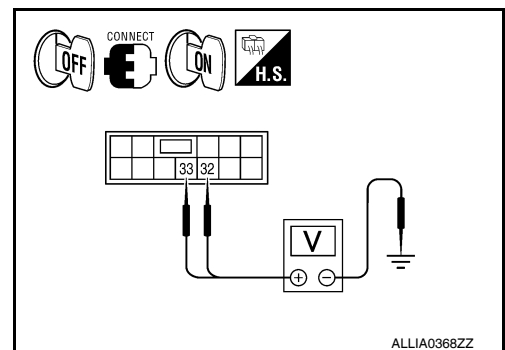
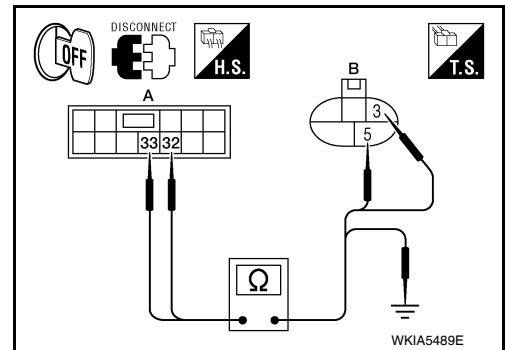

FRONT WIPER AND WASHER SYSTEM

< SERVICE INFORMATION >

3. Start auto active test. Refer to [PG-20. "Auto Active Test"](#).
4. Check voltage between IPDM E/R connector and ground while front wiper (HI, LO) is operating.

Terminal		Condition	Voltage (Approx.)
(+)	(-)		
IPDM E/R connector	Terminal		
E45	33	Stopped	0V
		LO operation	Battery voltage
	23	Stopped	0V
		HI operation	Battery voltage

OK or NG

- OK >> Replace front wiper motor. Refer to [WW-22. "Removal and Installation of Front Wiper Drive Assembly"](#).
- NG >> Replace IPDM E/R. Refer to [PG-27. "Removal and Installation of IPDM E/R"](#).

Front Wiper Does Not Return to Stop Position (After Front Wiper Operates for 10 Seconds, They Stop for 20 Seconds, and After Repeating the Operation Five Times, They Become Inoperative)

INFOID:000000007330363

CAUTION:

- When auto-stop signal has not varied for 10 seconds or longer while IPDM E/R is operating front wipers, IPDM E/R considers that front wipers are locked, and stops wiper output. That causes this symptom.
- This status can be checked by "DATA MONITOR" of "IPDM E/R" on which "WIPER PROT" item shows "BLOCK".

1. CHECK FRONT WIPER STOP SIGNAL

With CONSULT

Select "IPDM E/R" on CONSULT. With "DATA MONITOR", make sure that "WIP AUTO STOP" turns "ACT P"-"STOP P" linked with wiper operation.

Without CONSULT

GO TO 2.

OK or NG

- OK >> Replace IPDM E/R. Refer to [PG-27. "Removal and Installation of IPDM E/R"](#).
- NG >> GO TO 2.

2. CHECK IPDM E/R

1. Turn ignition switch ON.
2. Check voltage between IPDM E/R connector and ground while front wiper motor is stopped and while it is operating.

Terminal		Condition	Voltage (Approx.)
(+)	(-)		
IPDM E/R connector	Terminal		
E46	38	Wiper stopped	0V
		Wiper operating	Battery voltage

OK or NG

- OK >> Replace IPDM E/R. Refer to [PG-27. "Removal and Installation of IPDM E/R"](#).
- NG >> GO TO 3.

3. CHECK FRONT WIPER AUTO STOP CIRCUIT

1. Turn ignition switch OFF.

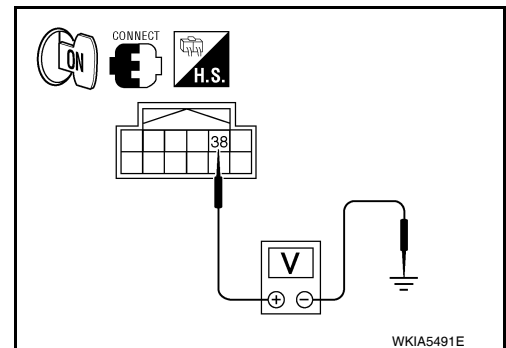

FRONT WIPER AND WASHER SYSTEM

< SERVICE INFORMATION >

- Disconnect IPDM E/R and wiper motor.
- Check continuity between IPDM E/R connector (A) and front wiper motor connector (B).

A		B		Continuity
Connector	Terminal	Connector	Terminal	
E46	38	E1	4	Yes

- Check continuity between IPDM E/R harness connector (A) and ground.

A		Ground	Continuity
Connector	Terminal		
E46	38		No

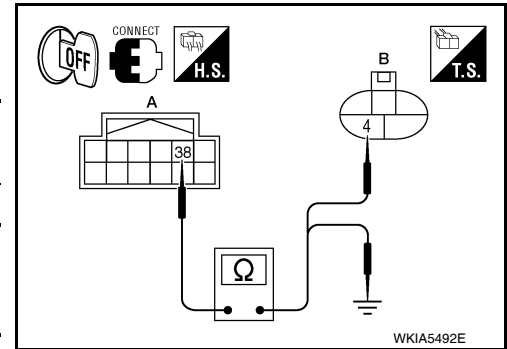

OK or NG

- OK >> Replace front wiper motor. Refer to [WW-22, "Removal and Installation of Front Wiper Drive Assembly"](#) .
- NG >> Repair or replace harness.

Only Front Wiper Low Does Not Operate

INFOID:000000007330364

1.ACTIVE TEST

With CONSULT

- Select "IPDM E/R" on CONSULT, and select "ACTIVE TEST" on "SELECT DIAG MODE" screen.
- Select "FRONT WIPER" on "SELECT TEST ITEM" screen.
- Touch "LO" screen.

Without CONSULT

Start auto active test. Refer to [PG-20, "Auto Active Test"](#) .

Does front wiper operate normally?

- YES >> Refer to [LT-65, "Combination Switch Inspection"](#) .
- NO >> GO TO 2.

2.CHECK FRONT WIPER MOTOR CIRCUIT

- Turn ignition switch OFF.
- Disconnect IPDM E/R and front wiper motor.
- Check continuity between IPDM E/R connector (A) and front wiper motor connector (B).

A		B		Continuity
Connector	Terminal	Connector	Terminal	
E45	33	E1	3	Yes

- Check continuity between IPDM E/R harness connector (A) and ground.

A		Ground	Continuity
Connector	Terminal		
E45	33		No

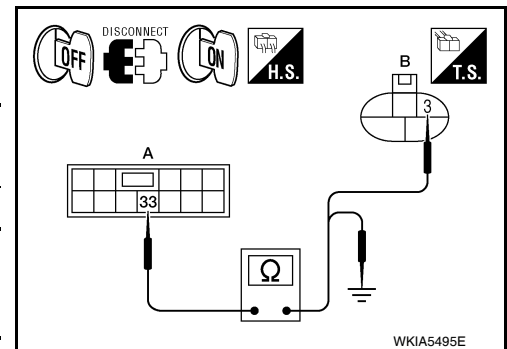

OK or NG

- OK >> GO TO 3.
- NG >> Repair or replace harness.

3.CHECK IPDM E/R

With CONSULT

FRONT WIPER AND WASHER SYSTEM

< SERVICE INFORMATION >

1. Connect IPDM E/R.
2. Turn ignition ON.
3. Select "IPDM E/R" on CONSULT, and select "ACTIVE TEST" on "SELECT DIAG MODE" screen.
4. Select "FRONT WIPER" on "SELECT TEST ITEM" screen.
5. Touch "LO" screen.
6. Check voltage between IPDM E/R connector and ground while front wiper LO is operating.

Terminal (+)		Terminal (-)	Continuity
IPDM E/R connector	Terminal		
E45	33	Ground	Battery voltage

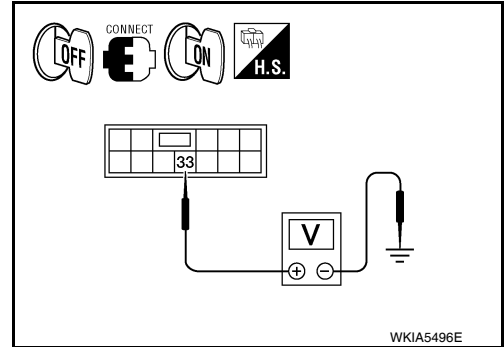

Without CONSULT

1. Connect IPDM E/R.
2. Turn ignition ON.
3. Start auto active test. Refer to [PG-20, "Auto Active Test"](#).
4. Check voltage between IPDM E/R connector and ground while front wiper LO is operating.

Terminal (+)		Terminal (-)	Continuity
IPDM E/R connector	Terminal		
E45	33	Ground	Battery voltage

OK or NG

- OK >> Replace front wiper motor. Refer to [WW-22, "Removal and Installation of Front Wiper Drive Assembly"](#).
- NG >> Replace IPDM E/R. Refer to [PG-27, "Removal and Installation of IPDM E/R"](#).

Only Front Wiper High Does Not Operate

INFOID:000000007330365

1. ACTIVE TEST

With CONSULT

1. Select "IPDM E/R" on CONSULT, and select "ACTIVE TEST" on "SELECT DIAG MODE" screen.
2. Select "FRONT WIPER" on "SELECT TEST ITEM" screen.
3. Touch "HI" screen.

Without CONSULT

Start auto active test. Refer to [PG-20, "Auto Active Test"](#).

Does front wiper operate normally?

- YES >> Refer to [LT-65, "Combination Switch Inspection"](#).
- NO >> GO TO 2.

2. CHECK FRONT WIPER MOTOR CIRCUIT

1. Turn ignition switch OFF.
2. Disconnect IPDM E/R connector E45 and front wiper motor connector E1.

FRONT WIPER AND WASHER SYSTEM

< SERVICE INFORMATION >

- Check continuity between IPDM E/R connector (A) E45 terminal 32 and front wiper motor connector (B) E1 terminal 1.

A		B		Continuity
Connector	Terminal	Connector	Terminal	
E45	32	E1	5	Yes

- Check continuity between IPDM E/R harness connector (A) E45 terminal 32 and ground.

A		Ground	Continuity
Connector	Terminal		
E45	32		No

OK or NG

- OK >> GO TO 3.
- NG >> Repair or replace harness.

3.CHECK IPDM E/R

Ⓜ With CONSULT

- Connect IPDM E/R connector E45.
- Turn ignition switch ON.
- Select "IPDM E/R" on CONSULT, and select "ACTIVE TEST" on "SELECT DIAG MODE" screen.
- Select "FRONT WIPER" on "SELECT TEST ITEM" screen.
- Touch "HI" screen.
- Check voltage between IPDM E/R connector E45 terminal 32 and ground while front wiper HI is operating.

Terminal		Voltage (Approx.)
(+)	(-)	
IPDM E/R connector	Terminal	
E45	32	Battery voltage

ⓧ Without CONSULT

- Connect IPDM E/R connector E45.
- Turn ignition switch ON.
- Start auto active test. Refer to [PG-20. "Auto Active Test"](#).
- Check voltage between IPDM E/R connector E45 terminal 32 and ground while front wiper HI is operating.

Terminal		Voltage (Approx.)
(+)	(-)	
IPDM E/R connector	Terminal	
E45	32	Battery voltage

OK or NG

- OK >> Replace front wiper motor. Refer to [WW-22. "Removal and Installation of Front Wiper Drive Assembly"](#).
- NG >> Replace IPDM E/R. Refer to [PG-27. "Removal and Installation of IPDM E/R"](#).

Only Front Wiper Intermittent Does Not Operate

INFOID:000000007330366

1.CHECK COMBINATION SWITCH (WIPER SWITCH)

Ⓜ With CONSULT

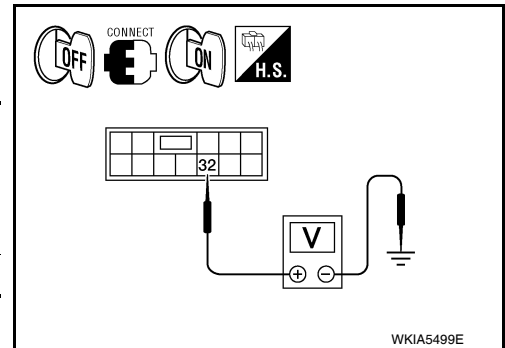
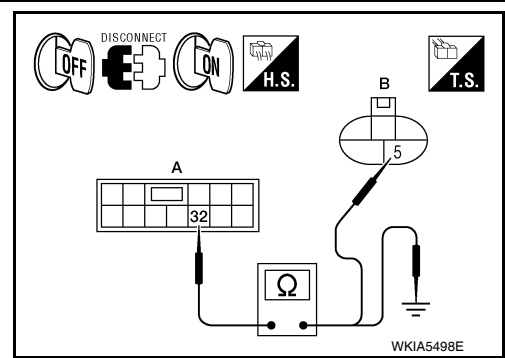

A
B
C
D
E
F
G
H
I
J
L
M
N
O
P

WW

FRONT WIPER AND WASHER SYSTEM

< SERVICE INFORMATION >

1. Select "BCM" on CONSULT, and select "WIPER" on "SELECT TEST ITEM" screen.
2. Select "DATA MONITOR" on "SELECT DIAG MODE" screen. Make sure that "FR WIPER INT", turn ON-OFF according to combination switch (wiper switch) operation.

⊗ Without CONSULT

Refer to [LT-65. "Combination Switch Inspection"](#) .

OK or NG

- OK >> Replace BCM. Refer to [BCS-19. "Removal and Installation of BCM"](#) .
NG >> Check combination switch (wiper switch). Refer to [LT-65. "Combination Switch Inspection"](#) .

Front Wiper Intermittent Operation Switch Position Cannot Be Adjusted

INFOID:000000007330367

1. CHECK CIRCUIT BETWEEN COMBINATION SWITCH (WIPER SWITCH) AND BCM

Ⓟ With CONSULT

1. Select "BCM" on CONSULT, and select "WIPER" on "SELECT TEST ITEM" screen.
2. Select "DATA MONITOR" on "SELECT DIAG MODE" screen. Make sure that "INT VOLUME", changes in order from 1 to 7 according to combination switch (wiper switch) operation.

⊗ Without CONSULT

Refer to [LT-65. "Combination Switch Inspection"](#) .

OK or NG

- OK >> Replace BCM. Refer to [BCS-19. "Removal and Installation of BCM"](#) .
NG >> Check combination switch (wiper switch). Refer to [LT-65. "Combination Switch Inspection"](#) .

Wiper Does Not Wipe When Front Washer Operates

INFOID:000000007330368

1. CHECK CIRCUIT BETWEEN COMBINATION SWITCH (WIPER SWITCH) AND BCM

Ⓟ With CONSULT

1. Select "BCM" on CONSULT, and select "WIPER" on "SELECT TEST ITEM" screen.
2. Select "DATA MONITOR" on "SELECT DIAG MODE" screen. Make sure that "FR WASHER SW" turn ON-OFF according to front combination switch (wiper switch) operation.

⊗ Without CONSULT

Refer to [LT-65. "Combination Switch Inspection"](#) .

OK or NG

- OK >> Replace BCM. Refer to [BCS-19. "Removal and Installation of BCM"](#) .
NG >> Check combination switch (wiper switch). Refer to [LT-65. "Combination Switch Inspection"](#) .

Front Wiper Does Not Stop

INFOID:000000007330369

1. CHECK CIRCUIT BETWEEN COMBINATION SWITCH (WIPER SWITCH) AND BCM

Ⓟ With CONSULT

1. Select "BCM" on CONSULT, and select "WIPER" on "SELECT TEST ITEM" screen.
2. Select "DATA MONITOR" on "SELECT DIAG MODE" screen. Make sure that "FR WIPER INT", "FR WIPER LOW", "FR WIPER HI", and "FR WASHER SW" turn ON-OFF according to front combination switch (wiper switch) operation.

⊗ Without CONSULT

Refer to [LT-65. "Combination Switch Inspection"](#) .

OK or NG

- OK >> Replace IPDM E/R. Refer to [PG-26. "IPDM E/R Power/Ground Circuit Inspection"](#) .
NG >> Check combination switch (wiper switch). Refer to [LT-65. "Combination Switch Inspection"](#) .

Removal and Installation of Front Wiper Arms

INFOID:000000007330370

REMOVAL

1. Turn combination switch (wiper switch) on to operate wiper motor, and then turn combination switch (wiper switch) off (auto stop).
2. Open hood, remove wiper arm caps, and remove wiper arm nuts.
3. Raise wiper arm, and remove wiper arm from the vehicle.

FRONT WIPER AND WASHER SYSTEM

< SERVICE INFORMATION >

INSTALLATION

1. Clean up the pivot area as shown. This will reduce possibility of wiper arm looseness.
2. Prior to wiper arm installation, turn on combination switch (wiper switch) to operate wiper motor and then turn it off (auto stop).
3. Push wiper arm onto pivot shaft, paying attention to blind spline.

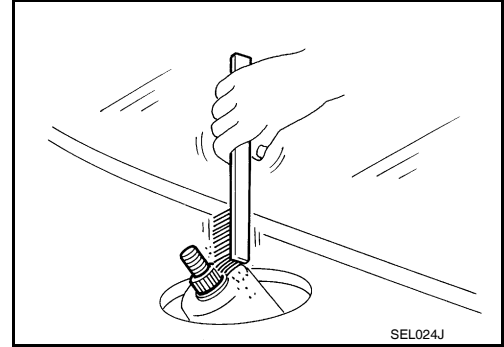

4. Lift the blade up and then set it down onto glass surface to set the blade center to clearance "L1" and "L2" immediately before temporarily tightening the wiper arm nuts.
5. Spray washer fluid. Turn on combination switch (wiper switch) to operate wiper motor and then turn it off.
6. Make sure that wiper blades stop within clearance "L1" and "L2" and reposition as necessary.

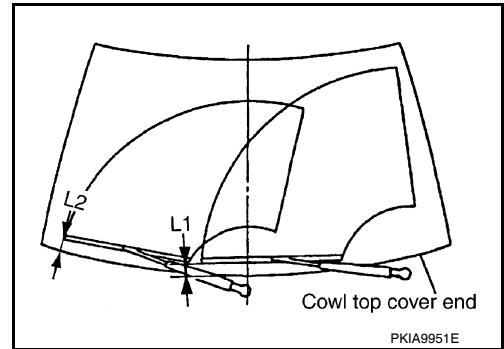

Clearance "L1" : 38.7 ± 7.5 mm (1.524 ± 0.295 in)

Clearance "L2" : 38.4 ± 7.5 mm (1.512 ± 0.295 in)

7. Tighten wiper arm nuts to specification.
8. Attach wiper arm caps.

Adjustment of Wiper Arm Stop Location

INFOID:000000007330371

ADJUSTMENT

To adjust the wiper arm stop location, the wiper arm must be removed and installed. Refer to [WW-20](#), "[Removal and Installation of Front Wiper Arms](#)".

A
B
C
D
E
F
G
H
I
J
L
M
N
O
P

WW

FRONT WIPER AND WASHER SYSTEM

< SERVICE INFORMATION >

Removal and Installation of Front Wiper Drive Assembly

INFOID:000000007330372

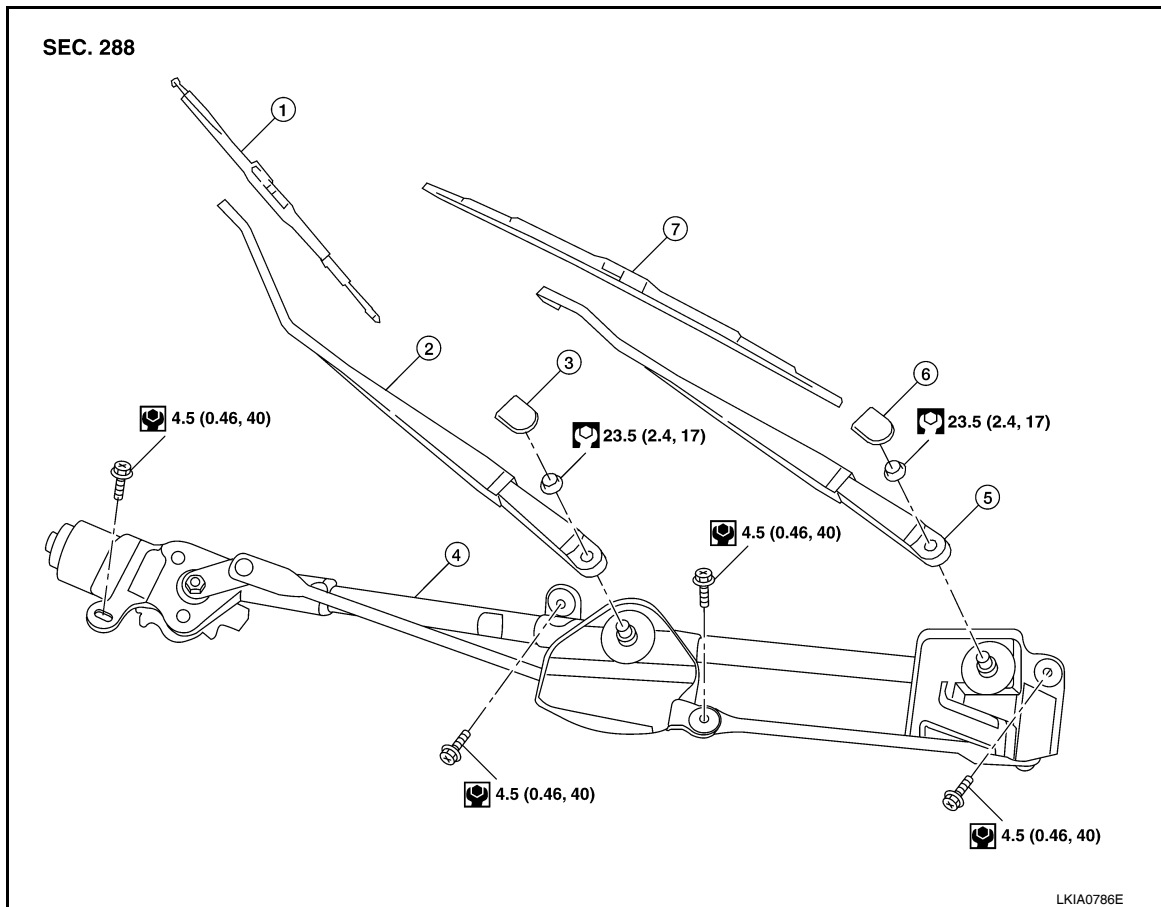

- | | | |
|-------------------------------|-----------------------|------------------|
| 1. Front RH wiper blade | 2. Front RH wiper arm | 3. Wiper arm cap |
| 4. Front wiper drive assembly | 5. Front LH wiper arm | 6. Wiper arm cap |
| 7. Front LH wiper blade | | |

REMOVAL

1. Operate the front wiper motor, and stop at the auto stop position.
2. Remove cowl top cover. Refer to [EI-22. "Removal and Installation"](#).
3. Disconnect wiper motor connector.
4. Remove front wiper drive assembly bolts, and remove front wiper drive assembly.

INSTALLATION

1. Install front wiper drive assembly.
2. Connect wiper motor connector. Turn combination switch (wiper switch) on to operate wiper motor, then turn combination switch (wiper switch) off (auto stop).
3. Install cowl top cover. Refer to [EI-22. "Removal and Installation"](#).

Removal and Installation of Front Washer Nozzle

INFOID:000000007330373

REMOVAL

1. Remove cowl top cover. Refer to [EI-22. "Removal and Installation"](#).
2. Remove washer tube.

FRONT WIPER AND WASHER SYSTEM

< SERVICE INFORMATION >

3. While pressing pawl (A) on the reverse side of front washer nozzle (1), remove front washer nozzle (1) from cowl top cover.

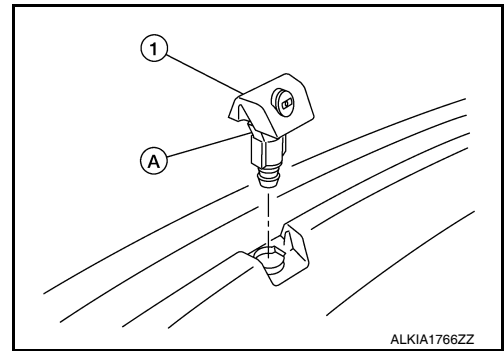

INSTALLATION

1. Install washer tube in nozzle.
2. Install nozzle to the vehicle.
3. Adjust nozzle spray location. Refer to [WW-24, "Washer Nozzle Adjustment"](#).

CAUTION:

The spray points differ, so be sure to install left and right nozzles correctly.

Inspection for Washer Nozzle

INFOID:000000007330374

CHECK VALVE INSPECTION

Blow air in the injection direction, and make sure that air flows only one way. Make sure that the reverse direction is not possible.

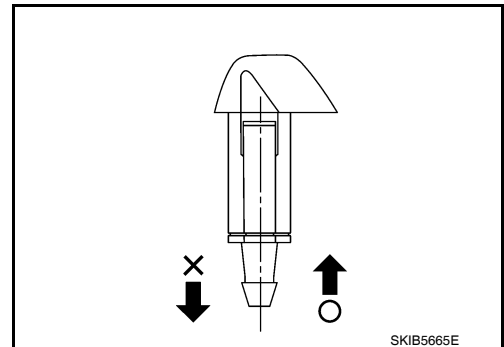

A
B
C
D
E
F
G
H
I
J
L
M
N
O
P

WW

FRONT WIPER AND WASHER SYSTEM

< SERVICE INFORMATION >

Washer Nozzle Adjustment

INFOID:000000007330375

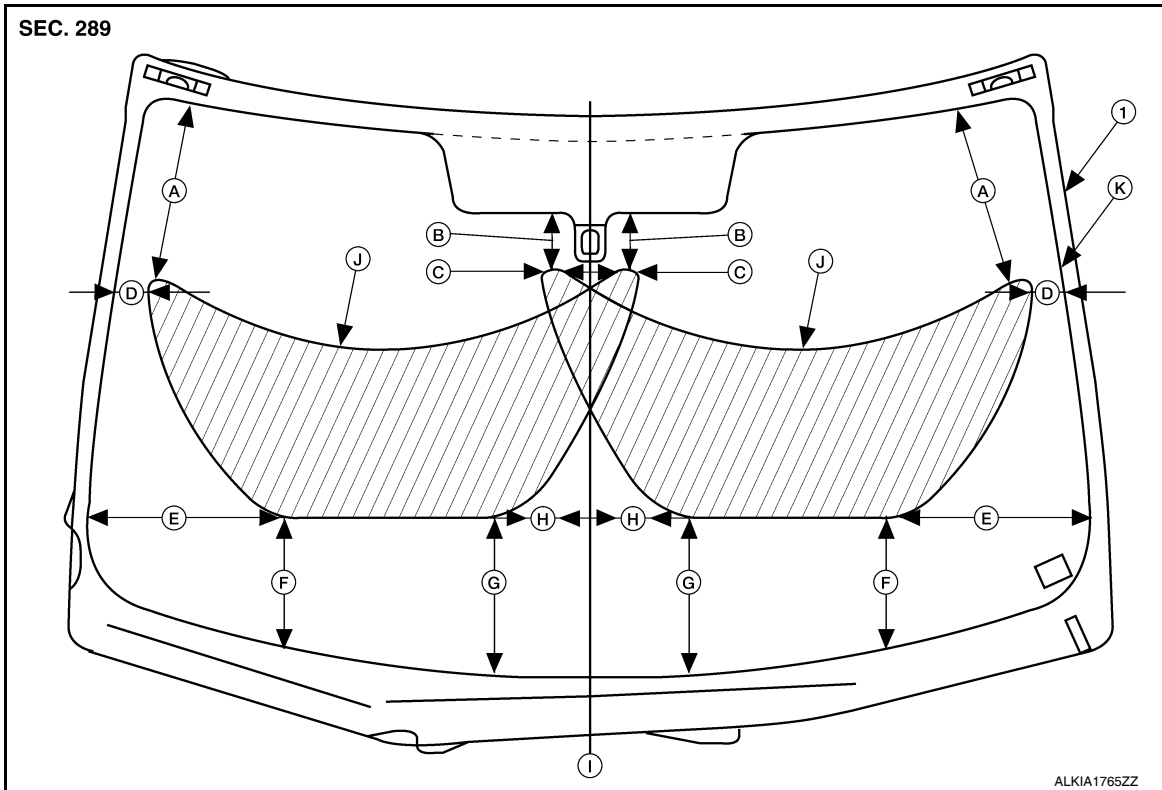

- | | | |
|-------------------------|-----------------------|---------------------|
| 1. Windshield | A. 211 mm (8.31 in) | B. 72 mm (2.83 in) |
| C. 51 mm (2.01 in) | D. 33 mm (1.30 in) | E. 228 mm (8.98 in) |
| F. 160 mm (6.30 in) | G. 200 mm (7.87 in) | H. 95 mm (3.74 in) |
| I. Center of windshield | J. Spray pattern area | K. Black mask |

- Adjust spray positions to match the positions as shown.
- Insert a suitable tool into the nozzle hole and move up/down and left/right to adjust to the specified spray position.

Washer Tube Layout

INFOID:000000007330376

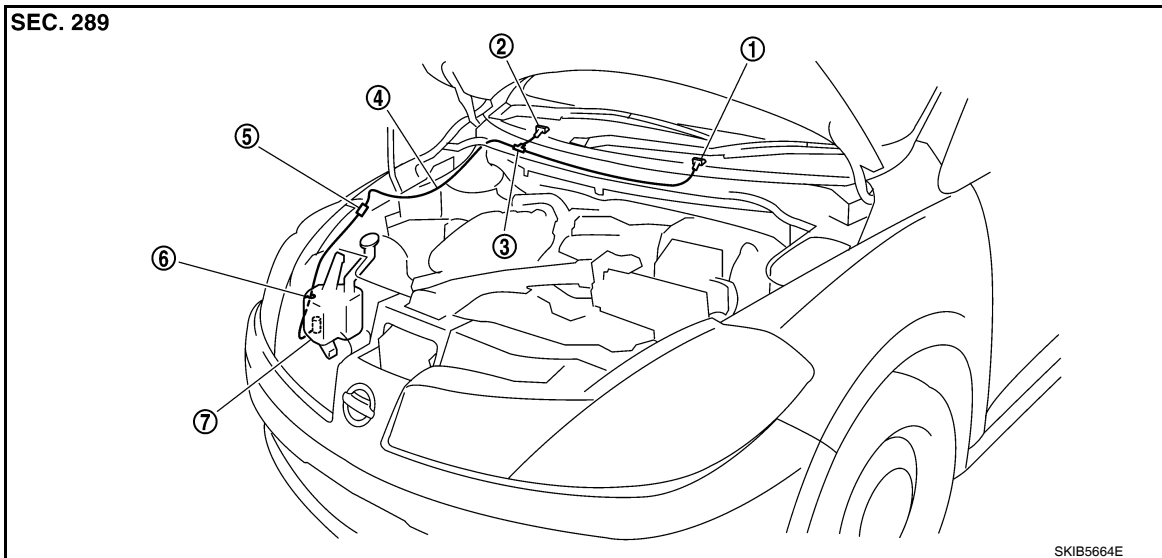

FRONT WIPER AND WASHER SYSTEM

< SERVICE INFORMATION >

- | | | |
|---------------------|---------------------|----------------------|
| 1. Washer nozzle LH | 2. Washer nozzle RH | 3. Joint washer tube |
| 4. Washer tube | 5. Clip | 6. Clamp |
| 7. Washer tank | | |

Removal and Installation of Front Wiper and Washer Switch

INFOID:000000007330377

REMOVAL

1. Remove the steering column cover. Refer to [IP-11, "Component Parts"](#).
2. Disconnect the wiper and washer switch connector.
3. Pull wiper and washer switch (1) toward the passenger door while pressing pawls (A) in direction shown by the arrow, and remove it from the base.

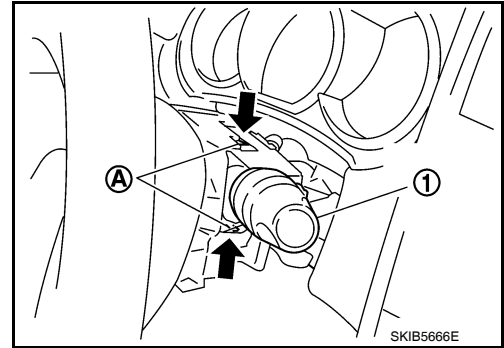

INSTALLATION

Installation is in the reverse order of removal.

Inspection of Front Wiper and Washer Switch Circuit

INFOID:000000007330378

Refer to [LT-65, "Combination Switch Inspection"](#).

Removal and Installation of Washer Tank

INFOID:000000007330379

REMOVAL

1. Remove the front grille. Refer to [EI-21, "Removal and Installation"](#).
2. Remove clip (A) and pull washer tank inlet (1) out of washer tank.
 - ⇐: Vehicle front

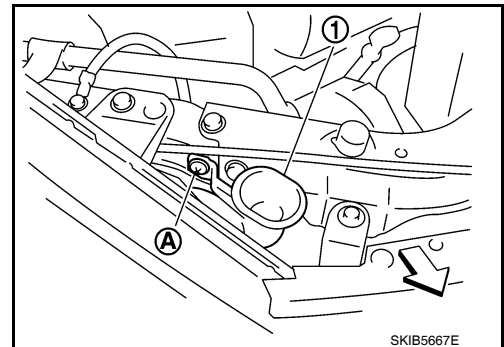

3. Remove the front fender protector. Refer to [EI-24, "Removal and Installation"](#).
4. Disconnect the washer motor connector and washer fluid level sensor connector.
5. Remove the washer tank screw (A).
 - ⇐: Vehicle front
6. Remove the washer tube (1), and remove washer tank (2) from the vehicle.
 - ⇐: Vehicle front

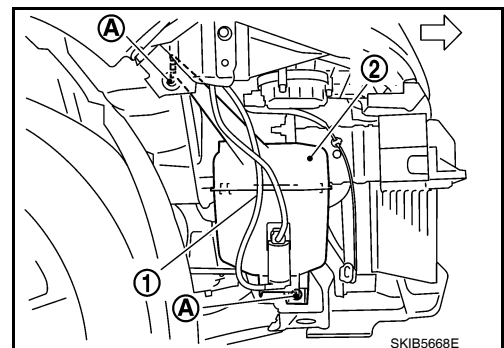

A
B
C
D
E
F
G
H
I
J
L
M
N
O
P

WW

FRONT WIPER AND WASHER SYSTEM

< SERVICE INFORMATION >

INSTALLATION

Installation is in the reverse order of removal.

Washer tank nuts : 4.5 N·m (0.46 kg-m, 40 in-lb)

Washer tank screw : 4.5 N·m (0.46 kg-m, 40 in-lb)

CAUTION:

After installation, add water up to the upper level of washer tank inlet, and check for water leaks.

Removal and Installation of Front Washer Motor

INFOID:000000007330380

REMOVAL

1. Remove the front fender protector RH. Refer to [EI-24. "Component"](#) .
2. Disconnect washer motor connector (1) and remove washer tube.
 - ⇐: Vehicle front
3. Pull out front washer motor (2) in the direction shown. Remove the front washer motor (2) from washer tank.
 - ⇐: Vehicle front

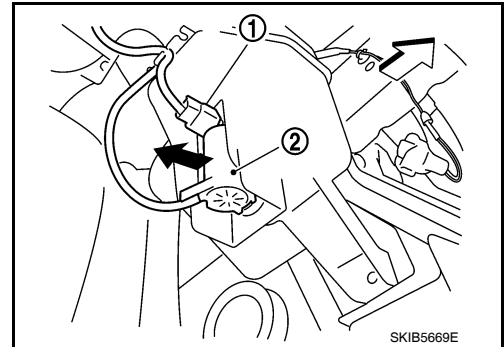

INSTALLATION

Installation is in the reverse order of removal.

CAUTION:

When installing washer motor, there should be no packing twists, etc.

REAR WIPER AND WASHER SYSTEM

< SERVICE INFORMATION >

REAR WIPER AND WASHER SYSTEM

Component Parts and Harness Connector Location

INFOID:000000007330381

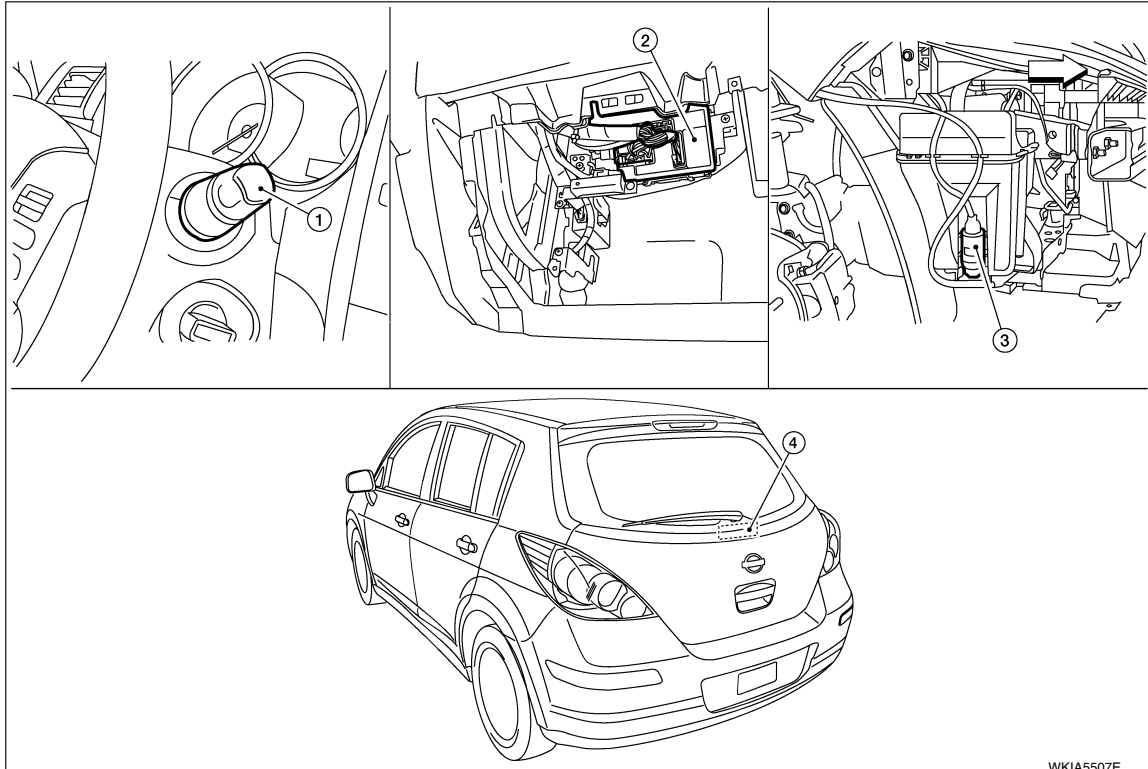

1. Combination switch (wiper switch) M28
 2. BCM M18, M19, M20 (view with glove box removed)
 3. Front and rear washer motor E2 (view with front bumper fascia removed)
 4. Rear wiper motor D404
- ⇐ Front

System Description

INFOID:000000007330382

WW

- The combination switch (wiper switch) is composed of a combination of 5 output terminals and 5 input terminals. Terminal combination status is read by the BCM (body control module) when switch is turned ON.
- The BCM controls rear wiper ON and INT (intermittent) operation.

Power is supplied at all times

- through 40A fusible link (letter **g**, located in fuse and fusible link box)
- to BCM terminal 70.

With the ignition switch in ON or START position, power is supplied

- through 15A fuse [No. 4, located in the fuse block (J/B)]
- to combination switch (wiper switch) terminal 2
- through 10A fuse [No. 6, located in the fuse block (J/B)]
- to BCM terminal 38.

Ground is supplied

- to BCM terminal 67, and
- to combination switch (wiper switch) terminal 12
- through grounds M57 and M61.

REAR WIPER OPERATION

When the ignition switch is in the ON or START position, and the rear combination switch (wiper switch) is in the ON position, the BCM detects a rear wiper ON request through the combination switch (wiper switch) reading function and controls the rear wiper motor as follows.

Power is supplied

- through BCM terminal 55
- to rear wiper motor terminal 1.

Ground is supplied

A
B
C
D
E
F
G
H
I
J
L
M
N
O
P

REAR WIPER AND WASHER SYSTEM

< SERVICE INFORMATION >

- to rear wiper motor terminal 3
- through grounds B117, B132 and D402.

With power and ground supplied, the rear wiper motor operates.

INTERMITTENT OPERATION

The rear wiper motor operates the wiper arm at low speed approximately every 7 seconds.

When the combination switch (wiper switch) is in the rear wiper INT position, the BCM detects a rear wiper INT request through the combination switch (wiper switch) reading function.

When BCM operates rear wiper motor, power is supplied

- through BCM terminal 55
- to rear wiper motor terminal 1.

Ground is supplied

- to rear wiper motor terminal 3
- through grounds B117, B132 and D402.

With power and ground supplied, the rear wiper operates in intermittent mode.

AUTO STOP OPERATION

When the rear wiper arm is not located at the base of the rear window, and the rear combination switch (wiper switch) is turned OFF, the rear wiper motor will continue to operate until the rear wiper arm is at the base of the rear window. When the rear wiper arm reaches the base, rear wiper motor terminals 2 and 1 are connected.

Ground is supplied

- to BCM terminal 44
- through rear wiper motor terminal 2, and
- through rear wiper motor terminal 3, and
- through grounds B117, B132 and D402.

REAR WASHER OPERATION

When the ignition switch is in the ON or START position, and the front and rear washer switches are OFF, the front and rear washer motor is supplied power

- through 15A fuse [No. 4, located in the fuse block (J/B)]
- to combination switch (wiper switch) terminal 14
- through combination switch (wiper switch) terminal 11
- to front and rear washer motor terminal 2.

When the rear combination switch (wiper switch) is in rear washer position, the BCM detects a rear washer signal by BCM combination switch (wiper switch) reading function. Combination switch (wiper switch) ground is supplied

- to front and rear washer motor terminal 1
- through combination switch (wiper switch) terminal 13, and
- through combination switch (wiper switch) terminal 12
- through grounds M57 and M61.

With ground supplied, the front and rear washer motor is operated in the rear direction.

When the BCM detects that the rear washer motor has operated for 0.4 seconds or longer, BCM operates the rear wiper motor.

When the BCM detects that the rear washer switch is in OFF, the rear wiper motor cycles approximately 3 times and then stops.

If the rear washer is operated with the rear combination switch (wiper switch) in the INT position, normal rear wiper operation will take over. Once the rear washer switch is released the rear wiper will return to INT operation.

BCM Combination Switch (Wiper Switch) Reading Function

Refer to [BCS-4, "System Description"](#) .

REAR WIPER AND WASHER SYSTEM

< SERVICE INFORMATION >

Terminal and Reference Value for BCM

INFOID:000000007330384

Refer to [BCS-12, "Terminal and Reference Value for BCM"](#) .

How to Proceed with Trouble Diagnosis

INFOID:000000007330385

1. Confirm the symptoms and customer complaint.
2. Understand operation description and function description. Refer to [WW-27, "System Description"](#) .
3. Perform the Preliminary Check. Refer to [WW-31, "Preliminary Check"](#) .
4. Check symptom and repair or replace the cause of malfunction.
5. Does the rear wiper operate normally? If YES: GO TO 6. If NO: GO TO 4.
6. Inspection End.

Preliminary Check

INFOID:000000007330386

CHECK POWER SUPPLY AND GROUND CIRCUIT FOR BCM

Refer to [BCS-16, "BCM Power Supply and Ground Circuit Inspection"](#) .

CONSULT Function (BCM)

INFOID:000000007330387

Refer to [WW-12, "CONSULT Function \(BCM\)"](#) .

Rear Wiper Does Not Operate

INFOID:000000007330388

1. REAR WIPER ACTIVE TEST

1. Select "BCM" on CONSULT, and select "WIPER" on "SELECT TEST ITEM" screen.
2. Select "ACTIVE TEST" on "SELECT DIAG MODE" screen.
3. Select "RR WIPER" on "SELECT TEST ITEM" screen.
4. Make sure rear wiper operates.

Wiper should operate.

OK or NG

- OK >> GO TO 6.
NG >> GO TO 2.

2. CHECK REAR WIPER MOTOR CIRCUIT

1. Turn ignition switch OFF.
2. Disconnect BCM and rear wiper motor.
3. Check continuity between rear wiper motor connector (A) D404 terminal 1 and BCM connector (B) M19 terminal 55.

55 - 1 : Continuity should exist.

OK or NO

- OK >> GO TO 3.
NO >> Repair or replace harness.

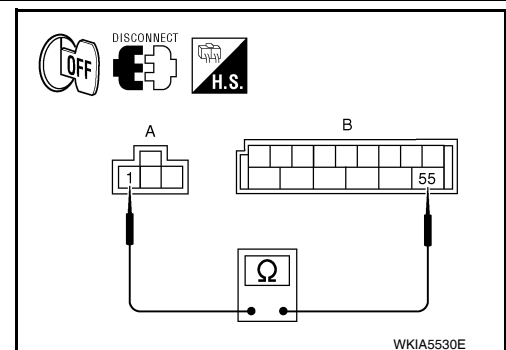

3. CHECK REAR WIPER MOTOR SHORT CIRCUIT

A
B
C
D
E
F
G
H
I
J
L
M
N
O
P

WW

REAR WIPER AND WASHER SYSTEM

< SERVICE INFORMATION >

Check continuity between rear wiper motor harness D404 terminal 1 and ground.

1 - Ground : Continuity should not exist.

OK or NG

- OK >> GO TO 4.
- NG >> Repair or replace harness.

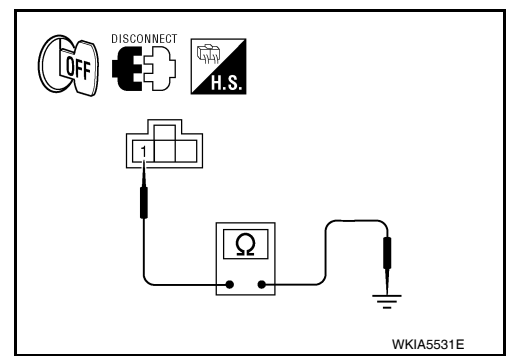

4. CHECK GROUND CIRCUIT

Check continuity between rear wiper motor connector D404 terminal 3 and ground.

3 - Ground : Continuity should exist.

OK or NG

- OK >> GO TO 5.
- NG >> Repair or replace harness.

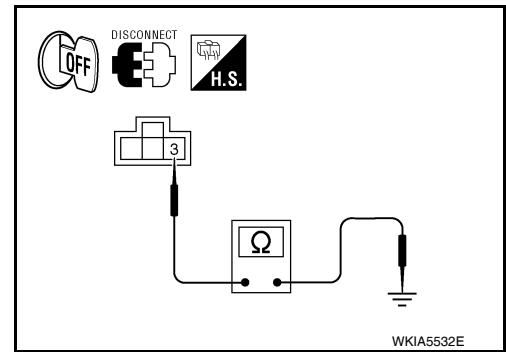

5. CHECK REAR WIPER OPERATING

1. Connect BCM and rear wiper motor.
2. Select "RR WIPER" during "ACTIVE TEST". Refer to [WW-13. "CONSULT Function \(IPDM E/R\)"](#). When rear wiper is operating, check voltage between BCM harness connector and ground.

BCM		(-)	Condition	Voltage (Approx.)
(+) Connector Terminal				
M19	55	Ground	Stopped	0V
			ON operation	Battery voltage

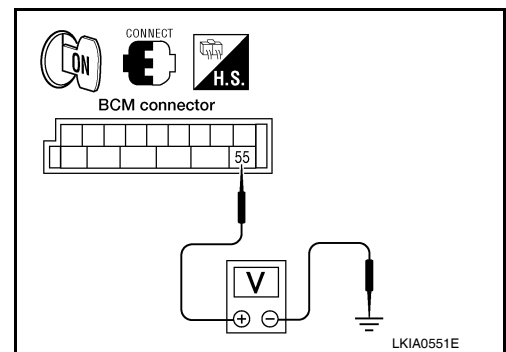

OK or NG

- OK >> Replace rear wiper motor. Refer to [WW-34. "Removal and Installation"](#).
- NG >> Replace BCM. Refer to [BCS-19. "Removal and Installation of BCM"](#).

6. CHECK COMBINATION SWITCH (WIPER SWITCH) INPUT SIGNAL

Select "BCM" on CONSULT. With "WIPER" data monitor, make sure "RR WIPER INT", "RR WIPER ON" turn ON-OFF according to operation of combination switch (wiper switch).

When combination switch (wiper switch) is in INT position : RR WIPER INT ON

When combination switch (wiper switch) is in ON position : RR WIPER ON ON

OK or NG

- OK >> Replace BCM. Refer to [BCS-19. "Removal and Installation of BCM"](#).
- NG >> Check the combination switch (wiper switch). Refer to [BCS-4. "System Description"](#).

REAR WIPER AND WASHER SYSTEM

< SERVICE INFORMATION >

Rear Wiper Stop Position Is Incorrect

INFOID:000000007330389

1. CHECK COMBINATION SWITCH (WIPER SWITCH) INPUT SIGNAL

Select "BCM" on CONSULT. With "WIPER" data monitor, make sure "RR WIPER STOP" turns ON-OFF according to wiper operation.

When combination switch : RR WIPER STOP OFF (wiper switch) is in OFF position

OK or NG

- OK >> Replace BCM. Refer to [BCS-19. "Removal and Installation of BCM"](#).
- NG >> GO TO 2.

2. CHECK REAR WIPER MOTOR CIRCUIT

1. Turn ignition switch OFF.
2. Disconnect BCM and rear wiper motor.
3. Check continuity between rear wiper motor connector (A) D404 terminal 2 and BCM connector (B) M19 terminal 44.

44 - 2 : Continuity should exist.

OK or NG

- OK >> GO TO 3.
- NG >> Repair or replace harness.

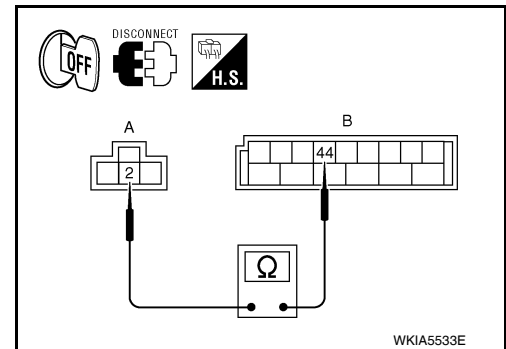

3. CHECK REAR WIPER MOTOR SHORT CIRCUIT

Check continuity between rear wiper motor connector D404 terminal 2 and ground.

2 - Ground : Continuity should not exist.

OK or NG

- OK >> GO TO 4.
- NG >> Repair or replace harness.

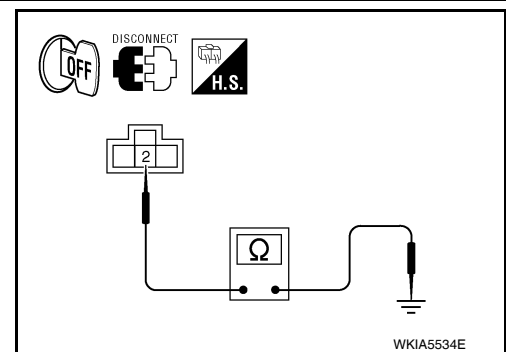

4. CHECK GROUND CIRCUIT

Check continuity between rear wiper motor connector D404 terminal 3 and ground.

3 - Ground : Continuity should exist.

OK or NG

- OK >> GO TO 5.
- NG >> Repair or replace harness.

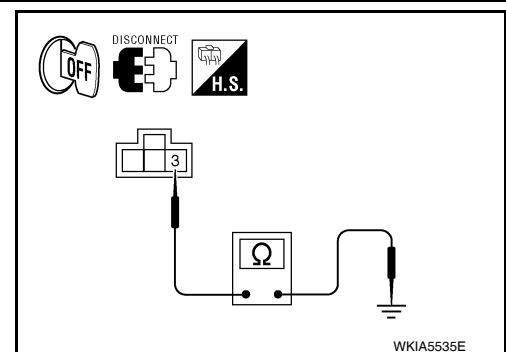

5. CHECK AUTO STOP SIGNAL

A
B
C
D
E
F
G
H
I
J
WW
L
M
N
O
P

REAR WIPER AND WASHER SYSTEM

< SERVICE INFORMATION >

1. Connect BCM.
2. Turn ignition switch ON.
3. Check voltage between rear wiper motor connector D404 terminal 2 and ground.

2 - Ground : Battery voltage should exist.

OK or NG

- OK >> Replace BCM. Refer to [BCS-19, "Removal and Installation of BCM"](#).
- NG >> Replace rear wiper motor. Refer to [WW-34, "Removal and Installation"](#).

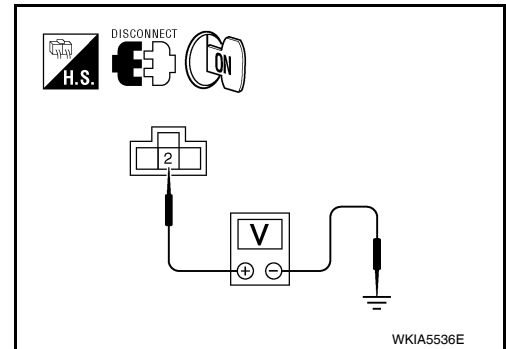

Only Rear Wiper Does Not Operate

INFOID:000000007330390

1. CHECK COMBINATION SWITCH (WIPER SWITCH) INPUT SIGNAL

Select "BCM" on CONSULT. With "WIPER" data monitor, make sure "RR WIPER ON" turns ON-OFF according to operation of combination switch (wiper switch).

When rear combination switch (wiper switch) is in ON position : RR WIPER ON ON

OK or NG

- OK >> Replace BCM. Refer to [BCS-19, "Removal and Installation of BCM"](#).
- NG >> Check the combination switch (wiper switch). Refer to [BCS-4, "System Description"](#).

Only Rear Wiper Intermittent Does Not Operate

INFOID:000000007330391

1. CHECK COMBINATION SWITCH (WIPER SWITCH) INPUT SIGNAL

Select "BCM" on CONSULT. With "WIPER" data monitor, make sure "RR WIPER INT" turns ON-OFF according to operation of combination switch (wiper switch).

When rear combination switch (wiper switch) is in INT position : RR WIPER INT ON

OK or NG

- OK >> Replace BCM. Refer to [BCS-19, "Removal and Installation of BCM"](#).
- NG >> Check the combination switch (wiper switch). Refer to [BCS-4, "System Description"](#).

Wiper Does Not Wipe When Rear Washer Operates

INFOID:000000007330392

1. CHECK COMBINATION SWITCH (WIPER SWITCH) INPUT SIGNAL

Select "BCM" on CONSULT. With "WIPER" data monitor, make sure "RR WASHER SW" turns ON-OFF according to operation of rear washer switch.

When rear combination switch (wiper switch) is in WASHER position : RR WASHER SW ON

OK or NG

- OK >> Replace BCM. Refer to [BCS-19, "Removal and Installation of BCM"](#).
- NG >> Check the combination switch (wiper switch). Refer to [BCS-4, "System Description"](#).

Removal and Installation

INFOID:000000007330393

REAR WIPER ARM

Removal

REAR WIPER AND WASHER SYSTEM

< SERVICE INFORMATION >

1. Raise wiper arm cover (1), and remove the rear wiper arm nut (A).
2. Remove the wiper arm.
3. Remove wiper blade.

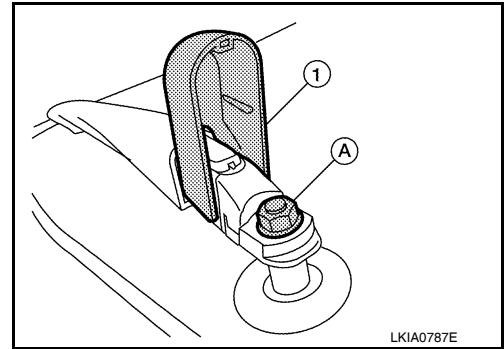

Installation

1. Operate rear wiper motor one full cycle, then turn "OFF" (Auto Stop).
2. Clean pivot area as shown. This will reduce the possibility of wiper arm looseness.
3. Install wiper blade.
4. Install wiper arm so that the arm rests in the stopper and tighten rear wiper arm nut.
5. Install wiper arm cover.

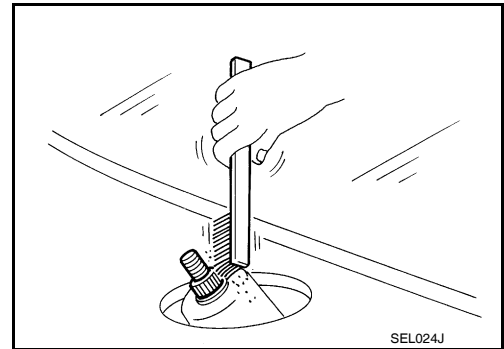

REAR WIPER MOTOR

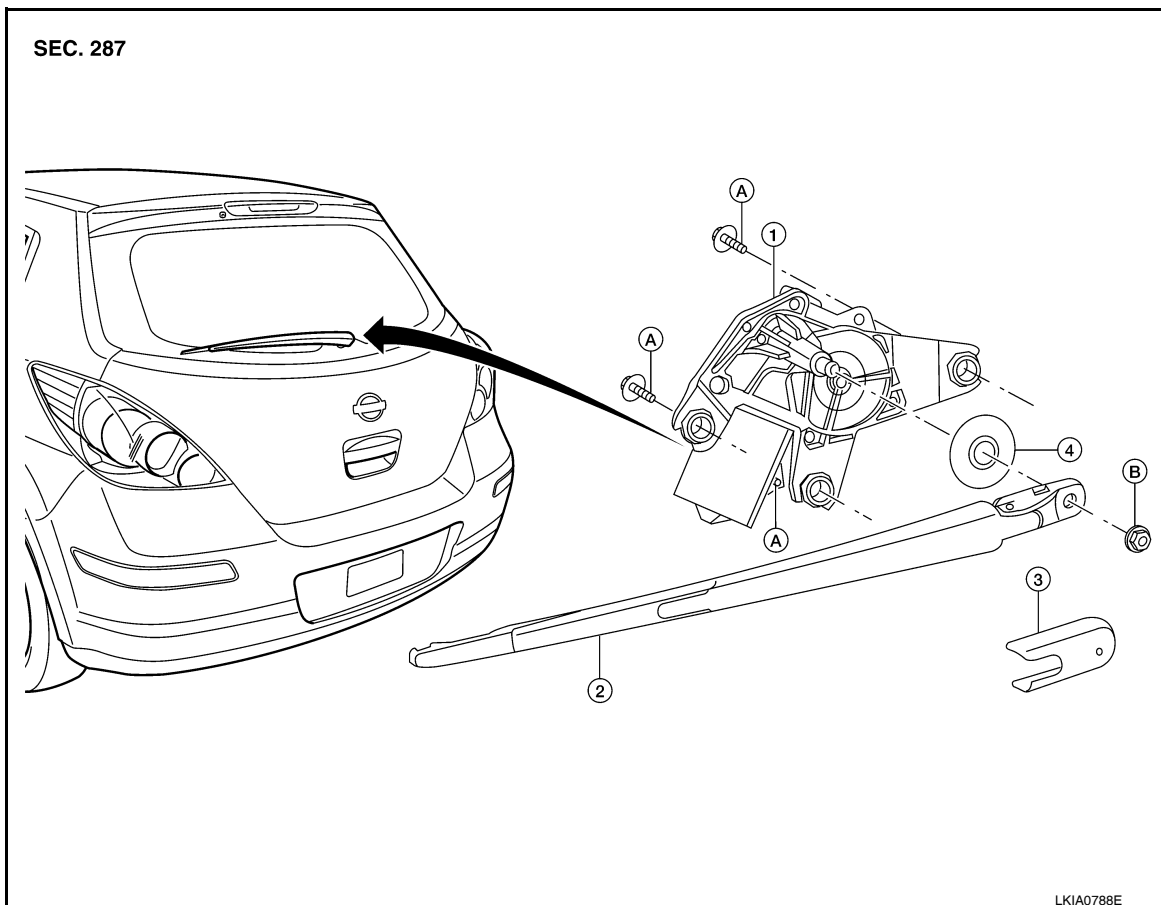

1. Rear wiper motor
4. Pivot cap

2. Rear wiper arm and blade
- A. Wiper motor bolts

3. Wiper arm cover
- B. Rear wiper motor nut

A
B
C
D
E
F
G
H
I
J
L
M
N
O
P

WW

REAR WIPER AND WASHER SYSTEM

< SERVICE INFORMATION >

Removal

1. Remove wiper arm. Refer to "REAR WIPER ARM" .
2. Raise arm cap.
3. Remove the rear wiper motor nut, remove the rear wiper arm and blade.
4. Remove the back door lower finisher. Refer to [EI-34. "Removal and Installation"](#) .
5. Disconnect the rear wiper motor connector (B).
6. Remove the bolts (A) and remove the rear wiper motor (1).

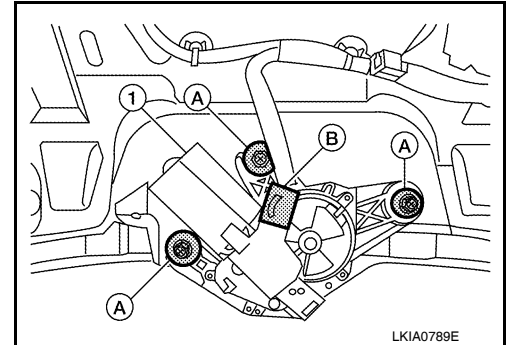

Installation

Installation is in the reverse order of removal.

CAUTION:

Do not drop the wiper motor or cause it to contact other parts.

REAR WASHER TUBE LAYOUT

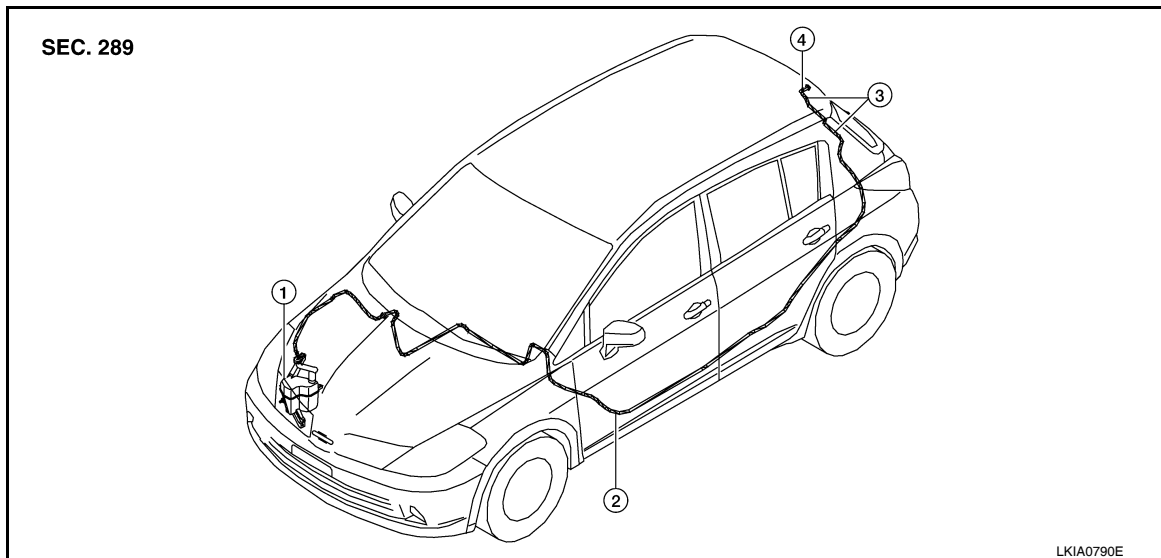

- | | | | | | |
|---|------------------------|---|--------------------------------|---|-------------|
| 1 | Washer fluid reservoir | 2 | Washer fluid tube to rear door | 3 | Check valve |
| 4 | Rear washer nozzle | | | | |

NOTE:

Connect the check valve (2) to the washer fluid tube (1) so that the directional arrow on the check valve (2) points towards the washer nozzle tube (3).

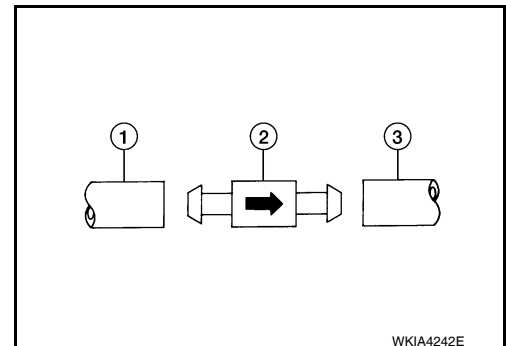

REAR WASHER NOZZLE

REAR WIPER AND WASHER SYSTEM

< SERVICE INFORMATION >

Removal

1. Remove the back door side garnish. Refer to [EI-34. "Removal and Installation"](#) .
2. Disconnect rear washer tube from rear washer nozzle.
3. Release retaining clips and remove washer nozzle.

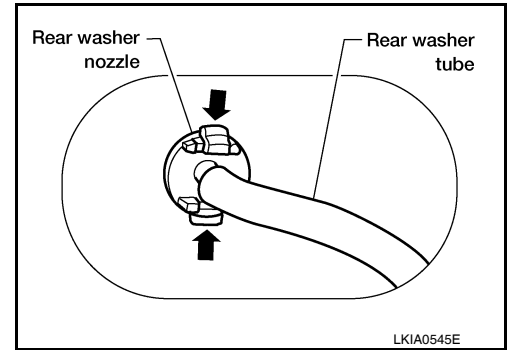

Installation

Installation is in the reverse order of removal.

NOTE:

- Do not pinch the rear washer tube when installing the back door side garnish.
- Inspect rear washer nozzle for proper spray pattern, adjust as necessary. Refer to [WW-37. "Washer Nozzle Adjustment"](#).

WASHER FLUID RESERVOIR

Refer to [WW-25. "Removal and Installation of Washer Tank"](#) .

WIPER AND WASHER SWITCH

Refer to [WW-25. "Removal and Installation of Front Wiper and Washer Switch"](#) .

WASHER MOTOR

Refer to [WW-26. "Removal and Installation of Front Washer Motor"](#) .

Washer Nozzle Adjustment

INFOID:000000007330394

Adjust the washer nozzle to specification using suitable tool as shown.

Adjustable range : $\pm 15^\circ$ (In any direction)

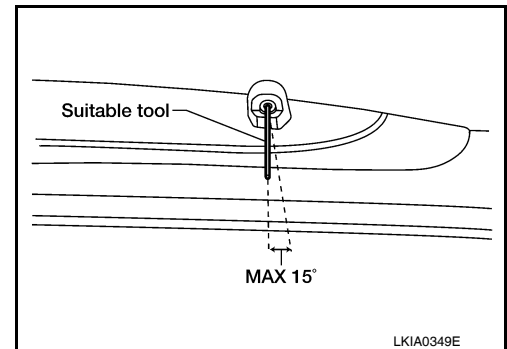

- Rear washer nozzle (1)
- Back glass (2)
- Center line (A)
- 148 mm (5.83 in) (B)
- 27 mm (1.06 in) (C)
- 35 mm (1.38 in) (D)
- Black printed area (E)
- Spray target area (F)

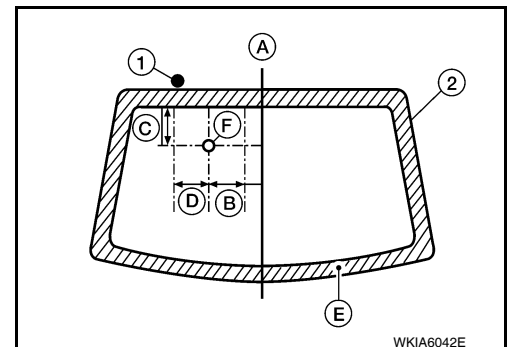

POWER SOCKET

< SERVICE INFORMATION >

POWER SOCKET

Wiring Diagram - P/SCKT -

INFOID:000000007330395

WW-P/SCKT-01

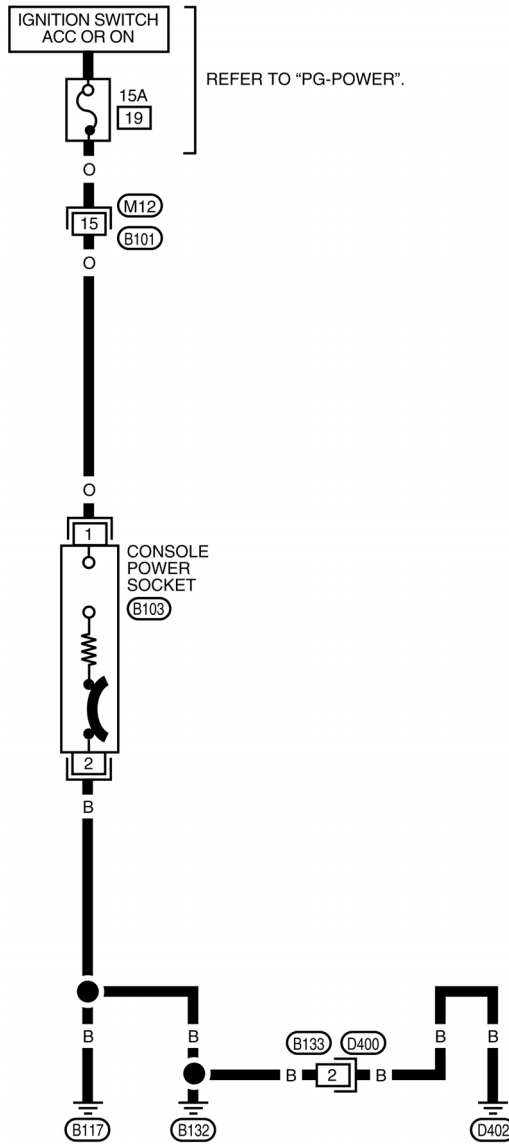

AALWA0379GB

Removal and Installation

INFOID:000000007330396

REMOVAL

1. Remove the fuse for the power socket.

POWER SOCKET

< SERVICE INFORMATION >

2. Remove the console mask. Refer to [JP-11, "Component Parts"](#).
3. Insert one end of the Tool (A) into one of the square holes inside the power socket.

Tool number: — (J-42059)

4. Lift up the handle of the Tool until the other end of the Tool is inside the socket and snaps into the other square hole in the power socket.
5. Pull the power socket straight out with the Tool.
6. Disconnect power socket connector.

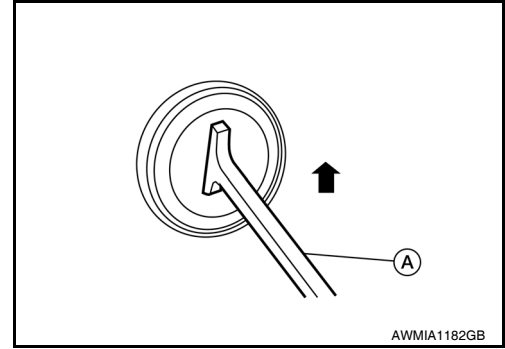

Installation

Installation is in the reverse order of removal.

NOTE:

Make sure to align the tab with the square notched area during installation.

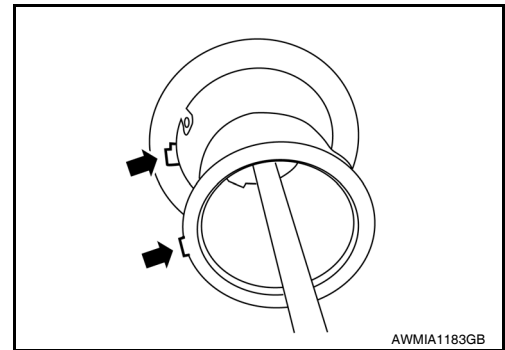

A
B
C
D
E
F
G
H
I
J
L
M
N
O
P

WW

HORN

< SERVICE INFORMATION >

HORN

Wiring Diagram - HORN -

INFOID:000000007330397

WW-HORN-01

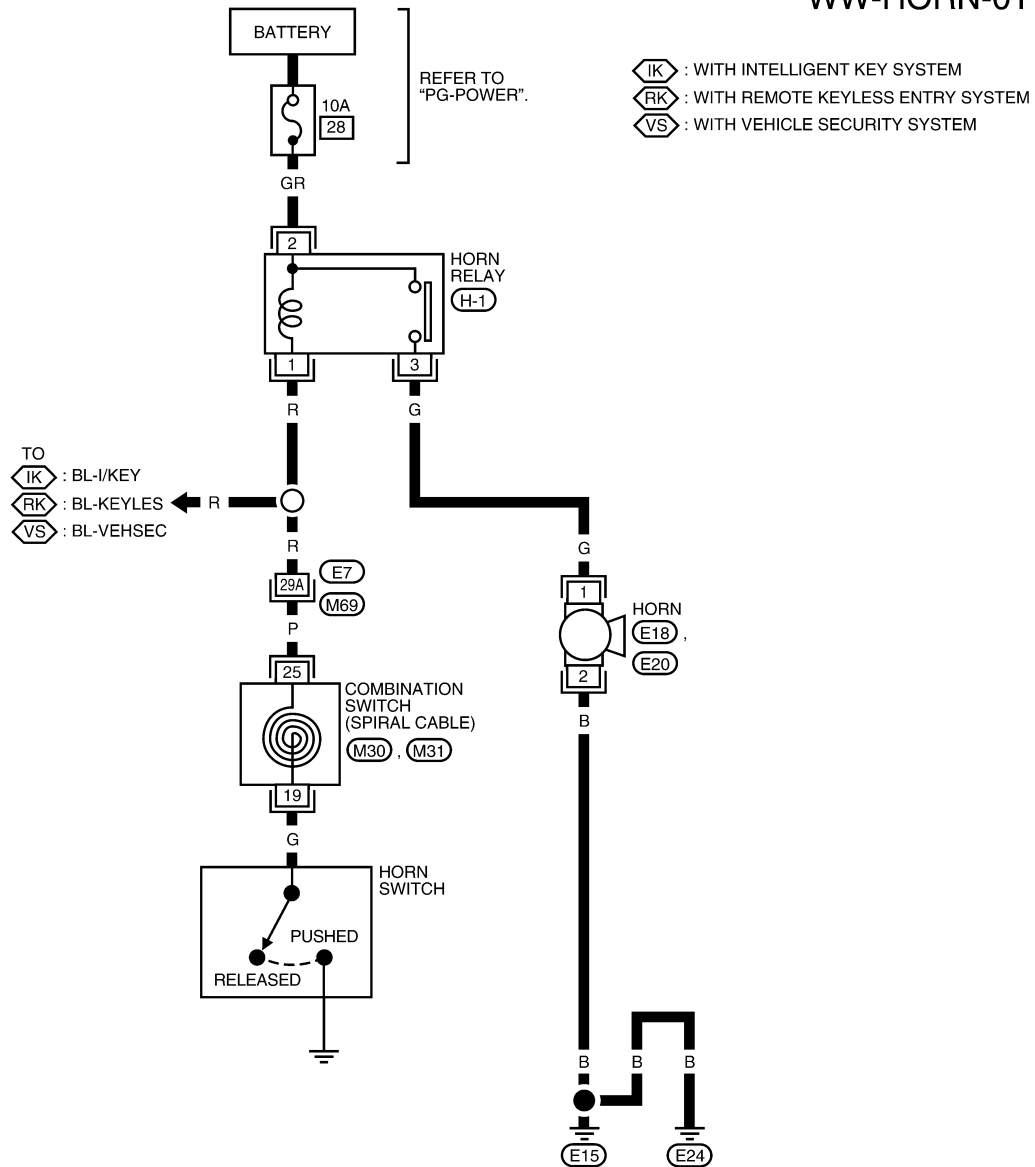

REFER TO THE FOLLOWING.
 (M69) - SUPER MULTIPLE JUNCTION (SMJ)

*: THIS CONNECTOR IS NOT SHOWN IN "HARNES LAYOUT" OF PG SECTION.

ABLWA1011GB

Removal and Installation

INFOID:000000007330398

REMOVAL

1. Remove the front grille. Refer to [EI-21, "Removal and Installation"](#).

HORN

< SERVICE INFORMATION >

2. Disconnect the horn connector.
3. Remove the horn nut (A) and remove the horn (1).

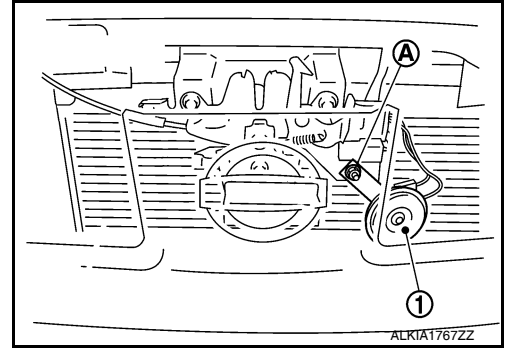

INSTALLATION

Installation is in the reverse order of removal.

A
B
C
D
E
F
G
H
I
J
L
M
N
O
P

WW