

AUTOMATIC TRANSMISSION

SECTION **AT**

CONTENTS

TROUBLE DIAGNOSIS - INDEX	4	
Alphabetical & P No. Index for DTC	4	
PRECAUTIONS	6	
Supplemental Restraint System (SRS) "AIR BAG" and "SEAT BELT PRE-TENSIONER"	6	
Precautions for On Board Diagnostic (OBD) System of A/T and Engine.....	6	
Precautions	6	
Service Notice or Precautions	8	
Wiring Diagrams and Trouble Diagnosis.....	9	
PREPARATION	10	
Special Service Tools	10	
OVERALL SYSTEM	12	
A/T Electrical Parts Location	12	
Circuit Diagram	13	
Cross-sectional View	14	
Hydraulic Control Circuit.....	15	
Shift Mechanism	16	
Control System	25	
Control Mechanism.....	26	
Control Valve	31	
ON BOARD DIAGNOSTIC SYSTEM		
DESCRIPTION	33	
Introduction	33	
OBD-II Function for A/T System.....	33	
One or Two Trip Detection Logic of OBD-II	33	
OBD-II Diagnostic Trouble Code (DTC).....	33	
Malfunction Indicator Lamp (MIL).....	37	
CONSULT-II	37	
Diagnostic Procedure Without CONSULT-II.....	46	
TROUBLE DIAGNOSIS - INTRODUCTION	55	
Introduction	55	
Work Flow.....	59	
TROUBLE DIAGNOSIS - BASIC INSPECTION	62	
A/T Fluid Check	62	
Stall Test	62	
Line Pressure Test.....	65	
Road Test.....	66	
TROUBLE DIAGNOSIS - GENERAL DESCRIPTION	84	
Symptom Chart.....	84	
TCM Terminals and Reference Value.....	97	
TROUBLE DIAGNOSIS FOR POWER SUPPLY	101	
Wiring Diagram - AT - MAIN.....	101	
Diagnostic Procedure	102	
DTC P0705 PARK/NEUTRAL POSITION (PNP) SWITCH	104	
Description	104	
Wiring Diagram - AT - PNP/SW.....	106	
Diagnostic Procedure	107	
Component Inspection.....	109	
DTC P0710 A/T FLUID TEMPERATURE SENSOR CIRCUIT	110	
Description	110	
Wiring Diagram - AT - FTS.....	112	
Diagnostic Procedure	113	
Component Inspection.....	115	
DTC P0720 VEHICLE SPEED SENSOR.A/T (REVOLUTION SENSOR)	116	
Description	116	
Wiring Diagram - AT - VSSA/T	118	
Diagnostic Procedure	119	
Component Inspection.....	120	
DTC P0725 ENGINE SPEED SIGNAL	121	
Description	121	
Wiring Diagram - AT - ENGSS	122	
Diagnostic Procedure	123	
DTC P0731 IMPROPER SHIFTING TO 1ST GEAR POSITION	125	
Description	125	
Wiring Diagram - AT - 1ST	128	
Diagnostic Procedure	129	
Component Inspection.....	130	
DTC P0732 IMPROPER SHIFTING TO 2ND GEAR POSITION	131	
Description	131	
Wiring Diagram - AT - 2ND.....	134	

GI
MA
EM
LC
EC
FE
CL
MT
AT
TF
PD
AX
SU
BR
ST
RS
BT
HA
SC
EL
IDX

CONTENTS (Cont'd)

Diagnostic Procedure	135	DTC BATT/FLUID TEMP SEN (A/T FLUID TEMP	
Component Inspection.....	135	SENSOR CIRCUIT AND TCM POWER SOURCE)....	193
DTC P0733 IMPROPER SHIFTING TO 3RD GEAR		Description	193
POSITION	137	Wiring Diagram - AT - BA/FTS	195
Description	137	Diagnostic Procedure	196
Wiring Diagram - AT - 3RD.....	140	Component Inspection.....	198
Diagnostic Procedure	141	DTC VEHICLE SPEED SENSOR.MTR	199
Component Inspection.....	142	Description.....	199
DTC P0734 IMPROPER SHIFTING TO 4TH GEAR		Wiring Diagram - AT - VSSMTR.....	201
POSITION	143	Diagnostic Procedure	202
Description	143	DTC TURBINE REVOLUTION SENSOR (VG33ER	
Wiring Diagram - AT - 4TH.....	147	ONLY)	203
Diagnostic Procedure	148	Description	203
Component Inspection.....	151	Wiring Diagram - AT - TRSA/T	205
DTC P0740 TORQUE CONVERTER CLUTCH		Diagnostic Procedure	206
SOLENOID VALVE.....	152	Component Inspection.....	207
Description	152	DTC CONTROL UNIT (RAM), CONTROL UNIT	
Wiring Diagram - AT - TCV.....	154	(ROM).....	208
Diagnostic Procedure	155	Description	208
Component Inspection.....	156	Diagnostic Procedure	209
DTC P0744 IMPROPER LOCK-UP OPERATION	157	DTC CONTROL UNIT (EEP ROM)	210
Description	157	Description	210
Wiring Diagram - AT - TCCSIG	159	Diagnostic Procedure	211
Diagnostic Procedure	160	TROUBLE DIAGNOSES FOR SYMPTOMS.....	212
Component Inspection.....	163	Wiring Diagram - AT - NONDTC	212
DTC P0745 LINE PRESSURE SOLENOID VALVE	164	1. O/D OFF Indicator Lamp Does Not Come On....	215
Description	164	2. Engine Cannot Be Started In P and N Position..	217
Wiring Diagram - AT - LPSV.....	166	3. In "P" Position, Vehicle Moves Forward Or	
Diagnostic Procedure	167	Backward When Pushed	218
Component Inspection.....	168	4. In N Position, Vehicle Moves	219
DTC P0750 SHIFT SOLENOID VALVE A	169	5. Large Shock. N -> R Position	221
Description	169	6. Vehicle Does Not Creep Backward In R	
Wiring Diagram - AT - SSV/A	171	Position	223
Diagnostic Procedure	172	7. Vehicle Does Not Creep Forward In D, 2 Or 1	
Component Inspection.....	173	Position	226
DTC P0755 SHIFT SOLENOID VALVE B	174	8. Vehicle Cannot Be Started From D ₁	229
Description	174	9. A/T Does Not Shift: D ₁ -> D ₂ Or Does Not	
Wiring Diagram - AT - SSV/B	176	Kickdown: D ₄ -> D ₂	232
Diagnostic Procedure	177	10. A/T Does Not Shift: D ₂ -> D ₃	235
Component Inspection.....	178	11. A/T Does Not Shift: D ₃ -> D ₄	238
DTC P1705 THROTTLE POSITION SENSOR	179	12. A/T Does Not Perform Lock-up.....	241
Description	179	13. A/T Does Not Hold Lock-up Condition	243
Wiring Diagram - AT - TPS.....	182	14. Lock-up Is Not Released.....	245
Diagnostic Procedure	183	15. Engine Speed Does Not Return To Idle (Light	
Component Inspection.....	187	Braking D ₄ -> D ₃).....	246
DTC P1760 OVERRUN CLUTCH SOLENOID		16. Vehicle Does Not Start From D ₁	248
VALVE.....	188	17. A/T Does Not Shift: D ₄ -> D ₃ , When	
Description	188	Overdrive Control Switch ON -> OFF	249
Wiring Diagram - AT - OVRCSV.....	190	18. A/T Does Not Shift: D ₃ -> 2 ₂ , When Selector	
Diagnostic Procedure	191	Lever D -> 2 Position	250
Component Inspection.....	192	19. A/T Does Not Shift: 2 ₂ -> 1 ₁ , When Selector	
		Lever 2 -> 1 Position	251

CONTENTS (Cont'd)

20. Vehicle Does Not Decelerate By Engine		
Brake.....	252	
21. TCM Self-diagnosis Does Not Activate (PNP, Overdrive Control and Throttle Position Switches Circuit Checks)	252	
A/T SHIFT LOCK SYSTEM	260	
Description	260	
Wiring Diagram - SHIFT -	261	
Diagnostic Procedure	262	
Component Check.....	264	
KEY INTERLOCK CABLE	265	
Components.....	265	
Removal.....	265	
Installation.....	266	
ON-VEHICLE SERVICE	267	
Control Valve Assembly and Accumulators.....	267	
Revolution Sensor Replacement.....	268	
Turbine Revolution Sensor Replacement (VG33ER only).....	268	
Rear Oil Seal Replacement.....	268	
Parking Components Inspection.....	269	
Park/Neutral Position (PNP) Switch Adjustment	270	
Manual Control Linkage Adjustment.....	270	
REMOVAL AND INSTALLATION	271	
Removal.....	271	
Installation.....	272	
OVERHAUL	274	
Components.....	274	
Oil Channel	276	
Locations of Needle Bearings, Thrust Washers and Snap Rings	277	
DISASSEMBLY	278	
REPAIR FOR COMPONENT PARTS	289	
Oil Pump.....	289	
Control Valve Assembly.....	293	GI
Control Valve Upper Body	299	
Control Valve Lower Body	304	MA
Reverse Clutch	306	
High Clutch	310	
Forward and Overrun Clutches	312	EM
Low & Reverse Brake.....	316	
Forward Clutch Drum Assembly.....	320	
Rear Internal Gear and Forward Clutch Hub	322	LC
Band Servo Piston Assembly	325	
Parking Pawl Components	329	
ASSEMBLY	331	EC
Assembly (1).....	331	
Adjustment	339	FE
Assembly (2).....	341	
SERVICE DATA AND SPECIFICATIONS (SDS)	348	
General Specifications.....	348	CL
Shift Schedule.....	348	
Stall Revolution.....	348	MT
Line Pressure.....	349	
Return Springs.....	349	
Accumulator O-ring.....	350	
Clutches and Brakes	350	AT
Oil Pump and Low One-way Clutch.....	353	
Total End Play.....	353	TF
Reverse Clutch Drum End Play	353	
Removal and Installation	353	PD
Shift Solenoid Valves	353	
Solenoid Valves	353	
A/T Fluid Temperature Sensor.....	354	AX
Turbine Revolution Sensor	354	
Revolution Sensor	354	
Dropping Resistor	354	SU

TROUBLE DIAGNOSIS — INDEX

Alphabetical & P No. Index for DTC

Alphabetical & P No. Index for DTC

NGAT0179

ALPHABETICAL INDEX FOR DTC

NGAT0179S01

Items (CONSULT-II screen terms)	DTC	Reference page
	CONSULT-II GST*1	
A/T 1ST GR FNCTN	P0731	AT-125
A/T 2ND GR FNCTN	P0732	AT-131
A/T 3RD GR FNCTN	P0733	AT-137
A/T 4TH GR FNCTN	P0734	AT-143
A/T TCC S/V FNCTN	P0744	AT-157
ATF TEMP SEN/CIRC	P0710	AT-110
ENGINE SPEED SIG	P0725	AT-121
L/PRESS SOL/CIRC	P0745	AT-164
O/R CLTCH SOL/CIRC	P1760	AT-188
PNP SW/CIRC	P0705	AT-104
SFT SOL A/CIRC*2	P0750	AT-169
SFT SOL B/CIRC*2	P0755	AT-174
TCC SOLENOID/CIRC	P0740	AT-152
TP SEN/CIRC A/T*2	P1705	AT-179
VEH SPD SEN/CIR AT*3	P0720	AT-116

*1: These numbers are prescribed by SAE J2012.

*2: When the fail-safe operation occurs, the MIL illuminates.

*3: The MIL illuminates when both the "Revolution sensor signal" and the "Vehicle speed sensor signal" meet the fail-safe condition at the same time.

TROUBLE DIAGNOSIS — INDEX

Alphabetical & P No. Index for DTC (Cont'd)

P NO. INDEX FOR DTC

-NGAT0179S02

DTC	Items (CONSULT-II screen terms)	Reference page
CONSULT-II GST*1		
P0705	PNP SW/CIRC	AT-104
P0710	ATF TEMP SEN/CIRC	AT-110
P0720	VEH SPD SEN/CIR AT*3	AT-116
P0725	ENGINE SPEED SIG	AT-121
P0731	A/T 1ST GR FNCTN	AT-125
P0732	A/T 2ND GR FNCTN	AT-131
P0733	A/T 3RD GR FNCTN	AT-137
P0734	A/T 4TH GR FNCTN	AT-143
P0740	TCC SOLENOID/CIRC	AT-152
P0744	A/T TCC S/V FNCTN	AT-157
P0745	L/PRESS SOL/CIRC	AT-164
P0750	SFT SOL A/CIRC*2	AT-169
P0755	SFT SOL B/CIRC*2	AT-174
P1705	TP SEN/CIRC A/T*2	AT-179
P1760	O/R CLTCH SOL/CIRC	AT-188

*1: These numbers are prescribed by SAE J2012.

*2: When the fail-safe operation occurs, the MIL illuminates.

*3: The MIL illuminates when both the "Revolution sensor signal" and the "Vehicle speed sensor signal" meet the fail-safe condition at the same time.

GI
MA
EM
LC
EC
FE
CL
MT
AT
TF
PD
AX
SU
BR
ST
RS
BT
HA
SC
EL
IDX

PRECAUTIONS

Supplemental Restraint System (SRS) "AIR BAG" and "SEAT BELT PRE-TENSIONER"

Supplemental Restraint System (SRS) "AIR BAG" and "SEAT BELT PRE-TENSIONER"

NGAT0001

The supplemental Restraint System such as "AIR BAG" and "SEAT BELT PRE-TENSIONER" used along with a seat belt, helps to reduce the risk or severity of injury to the driver and front passenger for certain types of collision. The Supplemental Restraint System consists of driver air bag module (located in the center of the steering wheel), front passenger air bag module (located on the instrument panel on passenger side), seat belt pre-tensioners, a diagnosis sensor unit, crash zone sensor, seat belt buckle switches, warning lamp, wiring harness and spiral cable.

Information necessary to service the system safely is included in the **RS section** of this Service Manual.

WARNING:

- To avoid rendering the SRS inoperative, which could increase the risk of personal injury or death in the event of a collision which would result in air bag inflation, all maintenance should be performed by an authorized NISSAN dealer.
- Improper maintenance, including incorrect removal and installation of the SRS, can lead to personal injury caused by unintentional activation of the system. For removal of Spiral Cable and Air Bag Module, see the RS section.
- Do not use electrical test equipment on any circuit related to the SRS unless instructed to in this Service Manual. SRS wiring harnesses can be identified by yellow and/or orange harness connectors.

Precautions for On Board Diagnostic (OBD) System of A/T and Engine

NGAT0002

The ECM has an on board diagnostic system. It will light up the malfunction indicator lamp (MIL) to warn the driver of a malfunction causing emission deterioration.

CAUTION:

- Be sure to turn the ignition switch OFF and disconnect the negative battery terminal before any repair or inspection work. The open/short circuit of related switches, sensors, solenoid valves, etc. will cause the MIL to light up.
- Be sure to connect and lock the connectors securely after work. A loose (unlocked) connector will cause the MIL to light up due to an open circuit. (Be sure the connector is free from water, grease, dirt, bent terminals, etc.)
- Be sure to route and secure the harnesses properly after work. Interference of the harness with a bracket, etc. may cause the MIL to light up due to a short circuit.
- Be sure to connect rubber tubes properly after work. A misconnected or disconnected rubber tube may cause the MIL to light up due to a malfunction of the fuel injection system, etc.
- Be sure to erase the unnecessary malfunction information (repairs completed) from the TCM and ECM before returning the vehicle to the customer.

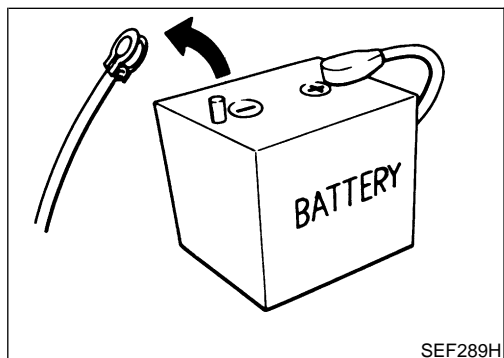

Precautions

NGAT0003

- Before connecting or disconnecting the TCM harness connector, turn ignition switch OFF and disconnect negative battery terminal. Failure to do so may damage the TCM. Because battery voltage is applied to TCM even if ignition switch is turned off.

PRECAUTIONS

Precautions (Cont'd)

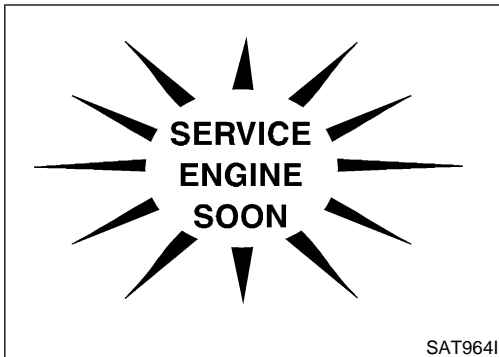
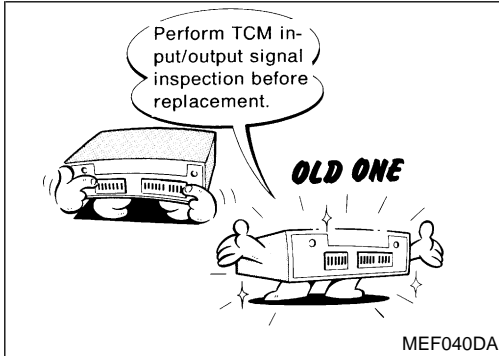
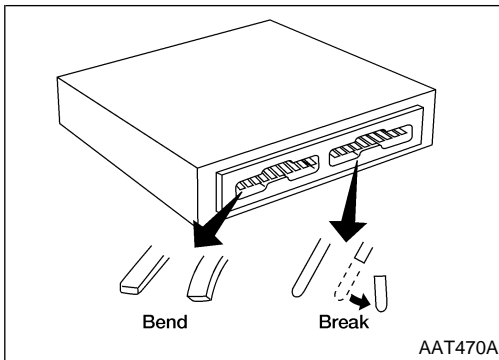

- When connecting or disconnecting pin connectors into or from TCM, take care not to damage pin terminals (bend or break).
Make sure that there are not any bends or breaks on TCM pin terminal, when connecting pin connectors.

GI

MA

EM

LC

EC

FE

CL

MT

- Before replacing TCM, perform TCM input/output signal inspection and make sure whether TCM functions properly or not. Refer to "TCM INSPECTION TABLE", AT-97.

AT

- After performing each TROUBLE DIAGNOSIS, perform "DTC (Diagnostic Trouble Code) CONFIRMATION PROCEDURE".
The DTC should not be displayed in the "DTC CONFIRMATION PROCEDURE" if the repair is completed.

TF

PD

AX

- Before proceeding with disassembly, thoroughly clean the outside of the transmission. It is important to prevent the internal parts from becoming contaminated by dirt or other foreign matter.
- Disassembly should be done in a clean work area.
- Use lint-free cloth or towels for wiping parts clean. Common shop rags can leave fibers that could interfere with the operation of the transmission.
- Place disassembled parts in order for easier and proper assembly.
- All parts should be carefully cleaned with a general purpose, non-flammable solvent before inspection or reassembly.
- Gaskets, seals and O-rings should be replaced any time the transmission is disassembled.
- It is very important to perform functional tests whenever they are indicated.
- The valve body contains precision parts and requires extreme care when parts are removed and serviced. Place disassembled valve body parts in order for easier and proper assembly. Care will also prevent springs and small parts from becoming scattered or lost.
- Properly installed valves, sleeves, plugs, etc. will slide along bores in valve body under their own weight.

SU

BR

ST

RS

BT

HA

SC

EL

IDX

PRECAUTIONS

Precautions (Cont'd)

- Before assembly, apply a coat of recommended ATF to all parts. Apply petroleum jelly to protect O-rings and seals, or hold bearings and washers in place during assembly. Do not use grease.
- Extreme care should be taken to avoid damage to O-rings, seals and gaskets when assembling.
- Replace ATF cooler if excessive foreign material is found in oil pan or clogging strainer. Refer to “ATF COOLER SERVICE”, AT-9.
- After overhaul, refill the transmission with new ATF.
- When the A/T drain plug is removed, only some of the fluid is drained. Old A/T fluid will remain in torque converter and ATF cooling system.
Always follow the procedures when changing A/T fluid. Refer to **MA-40**, “Changing A/T Fluid”.

Service Notice or Precautions

NGAT0004

FAIL-SAFE

NGAT0004S01

The TCM has an electronic Fail-Safe (limp home mode). This allows the vehicle to be driven even if a major electrical input/output device circuit is damaged.

Under Fail-Safe, the vehicle always runs in third gear, even with a shift lever position of 1, 2 or D. The customer may complain of sluggish or poor acceleration.

When the ignition key is turned ON following Fail-Safe operation, O/D OFF indicator lamp blinks for about 8 seconds. Refer to “TCM SELF-DIAGNOSTIC PROCEDURE (NO TOOLS)”, AT-47.

The blinking of the O/D OFF indicator lamp for about 8 seconds will appear only once and be cleared. The customer may resume normal driving conditions.

Always follow the “Work Flow”. Refer to AT-59.

The SELF-DIAGNOSIS results will be as follows:

The first SELF-DIAGNOSIS will indicate damage to the vehicle speed sensor or the revolution sensor.

During the next SELF-DIAGNOSIS, performed after checking the sensor, no damages will be indicated.

TORQUE CONVERTER SERVICE

NGAT0004S04

The torque converter should be replaced under any of the following conditions:

- External leaks in the hub weld area.
- Converter hub is scored or damaged.
- Converter pilot is broken, damaged or fits poorly into crankshaft.
- Steel particles are found after flushing the cooler and cooler lines.
- Pump is damaged or steel particles are found in the converter.
- Vehicle has TCC shudder and/or no TCC apply. Replace only after all hydraulic and electrical diagnoses have been made. (Converter clutch material may be glazed.)
- Converter is contaminated with engine coolant containing antifreeze.
- Internal failure of stator roller clutch.
- Heavy clutch debris due to overheating (blue converter).
- Steel particles or clutch lining material found in fluid filter or on magnet when no internal parts in unit are worn or damaged — indicates that lining material came from converter.

The torque converter should not be replaced if:

- The fluid has an odor, is discolored, and there is no evidence of metal or clutch facing particles.
- The threads in one or more of the converter bolt holes are damaged.

PRECAUTIONS

Service Notice or Precautions (Cont'd)

- Transmission failure did not display evidence of damaged or worn internal parts, steel particles or clutch plate lining material in unit and inside the fluid filter.
- Vehicle has been exposed to high mileage (only). The exception may be where the torque converter clutch dampener plate lining has seen excess wear by vehicles operated in heavy and/or constant traffic, such as taxi, delivery or police use.

GI

MA

ATF COOLER SERVICE

NGAT0004S02

Replace ATF cooler if excessive foreign material is found in oil pan or clogging strainer.

Replace radiator lower tank (which includes ATF cooler) with a new one and flush cooler line using cleaning solvent and compressed air.

EM

OBD-II SELF-DIAGNOSIS

NGAT0004S03

- A/T self-diagnosis is performed by the TCM in combination with the ECM. The results can be read through the blinking pattern of the O/D OFF indicator or the malfunction indicator lamp (MIL). Refer to "SELF-DIAGNOSTIC RESULT TEST MODE" the table on AT-38 for the indicator used to display each self-diagnostic result.
- The self-diagnostic results indicated by the MIL are automatically stored in both the ECM and TCM memories.

LC

EC

FE

Always perform the procedure "HOW TO ERASE DTC" on AT-35 to complete the repair and avoid unnecessary blinking of the MIL.

- The following self-diagnostic items can be detected using ECM self-diagnostic results mode* only when the O/D OFF indicator lamp does not indicate any malfunctions.
 - Park/neutral position (PNP) switch
 - A/T 1st, 2nd, 3rd, or 4th gear function
 - A/T TCC S/V function (lock-up)

CL

MT

*: For details of OBD-II, refer to **EC-660** (VG33E only) or **EC-1232** (VG33ER only), "ON BOARD DIAGNOSTIC SYSTEM DESCRIPTION".

AT

- **Certain systems and components, especially those related to OBD, may use a new style slide-locking type harness connector. For description and how to disconnect, refer to EL-6, "Description".**

TF

Wiring Diagrams and Trouble Diagnosis

NGAT0005

When you read wiring diagrams, refer to the following:

- Refer to **GI-10**, "HOW TO READ WIRING DIAGRAMS".
- Refer to **EL-10**, "POWER SUPPLY ROUTING" for power distribution circuit.

PD

AX

When you perform trouble diagnosis, refer to the following:

- Refer to **GI-33**, "How to Follow Test Groups in Trouble Diagnoses".
- Refer to **GI-22**, "HOW TO PERFORM EFFICIENT DIAGNOSIS FOR AN ELECTRICAL INCIDENT".

SU

BR

ST

RS

BT

HA

SC

EL

IDX

PREPARATION

Special Service Tools

Special Service Tools

NGAT0006

The actual shapes of Kent-Moore tools may differ from those of special service tools illustrated here.

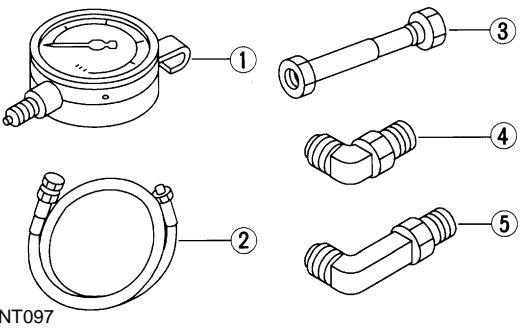
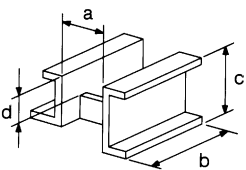
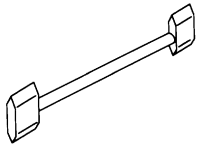
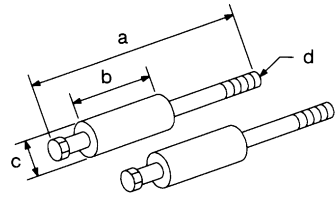
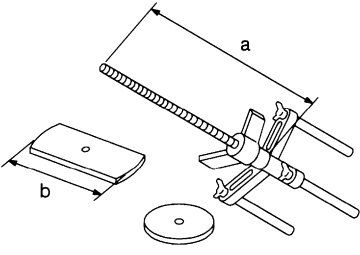
Tool number (Kent-Moore No.) Tool name	Description
ST2505S001 (J34301-C) Oil pressure gauge set 1 ST25051001 (—) Oil pressure gauge 2 ST25052000 (—) Hose 3 ST25053000 (—) Joint pipe 4 ST25054000 (—) Adapter 5 ST25055000 (—) Adapter	Measuring line pressure  NT097
ST07870000 (J37068) Transmission case stand	Disassembling and assembling A/T a: 182 mm (7.17 in) b: 282 mm (11.10 in) c: 230 mm (9.06 in) d: 100 mm (3.94 in)  NT421
KV31102100 (J37065) Torque converter one-way clutch check tool	Checking one-way clutch in torque converter  NT098
ST25850000 (J25721-A) Sliding hammer	Removing oil pump assembly a: 179 mm (7.05 in) b: 70 mm (2.76 in) c: 40 mm (1.57 in) dia. d: M12 x 1.75P  NT422
KV31102400 (J34285 and J34285-87) Clutch spring compressor	Removing and installing clutch return springs a: 320 mm (12.60 in) b: 174 mm (6.85 in)  NT423

PREPARATION

Special Service Tools (Cont'd)

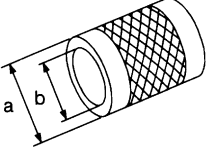
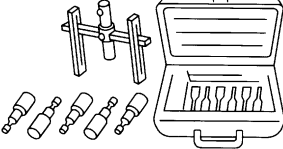
Tool number (Kent-Moore No.) Tool name	Description		
ST33200000 (J26082) Drift	 <p>NT091</p>	Installing oil pump housing oil seal Installing rear oil seal a: 60 mm (2.36 in) dia. b: 44.5 mm (1.752 in) dia.	GI MA EM
(J34291) Shim setting gauge set	 <p>NT101</p>	Selecting oil pump cover bearing race and oil pump thrust washer	LC EC FE
			CL MT
			AT
			TF
			PD
			AX
			SU
			BR
			ST
			RS
			BT
			HA
			SC
			EL
			IDX

OVERALL SYSTEM

A/T Electrical Parts Location

NGAT0007

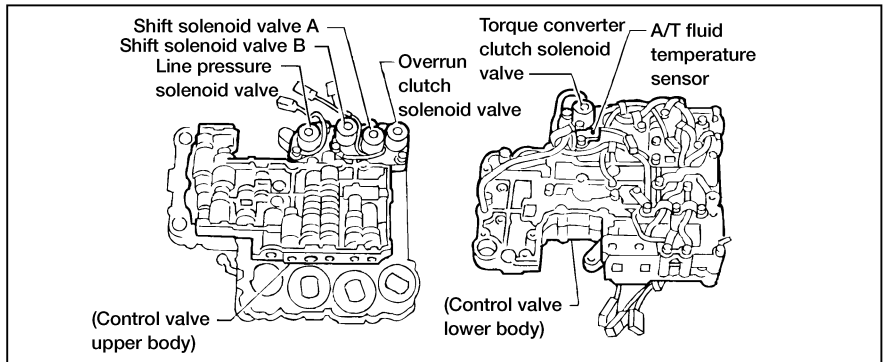
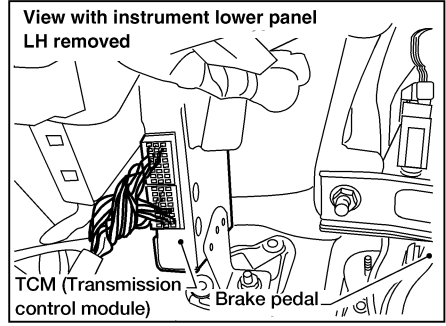
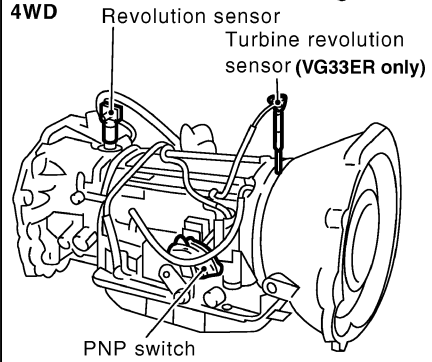
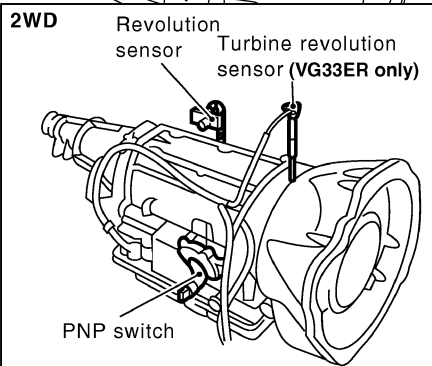
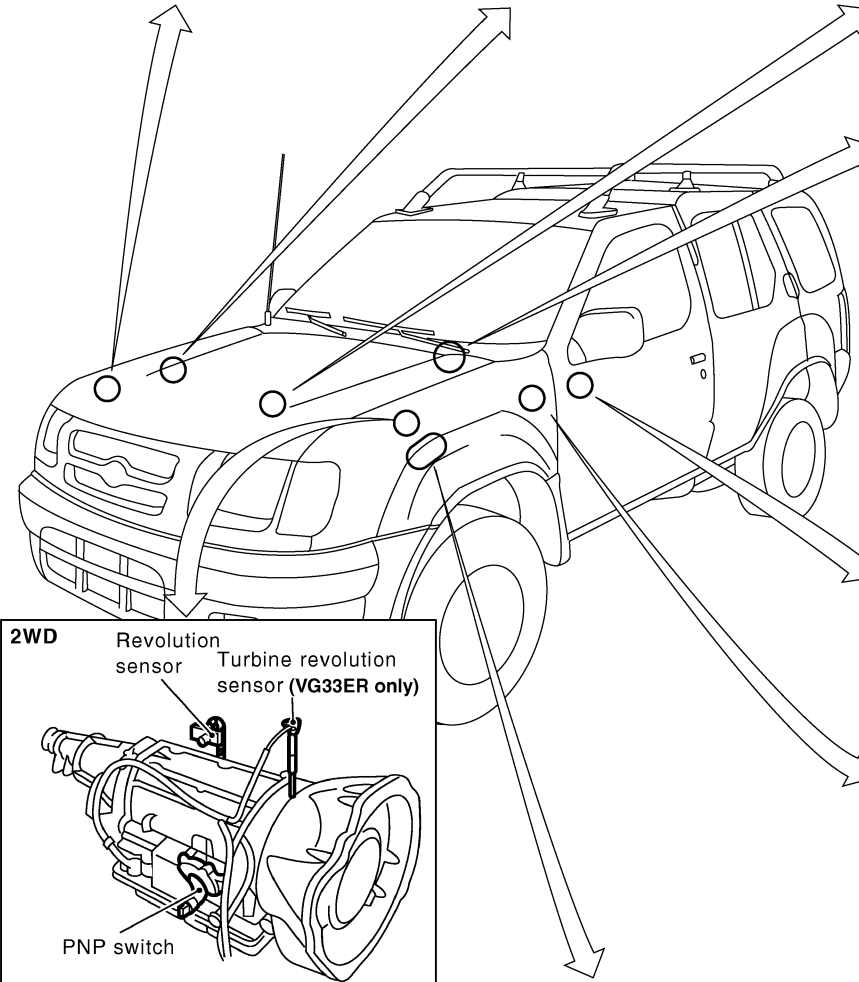
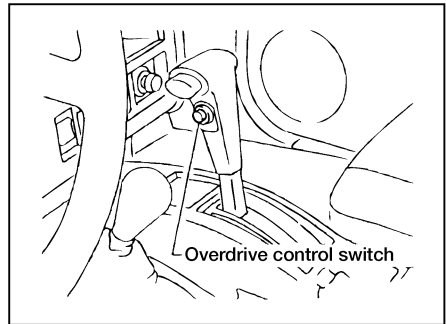
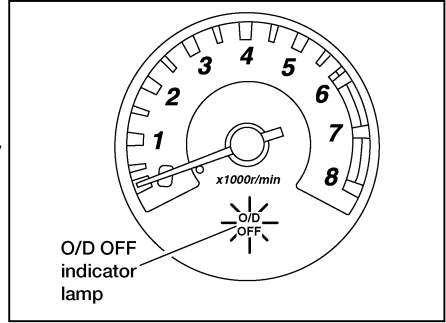
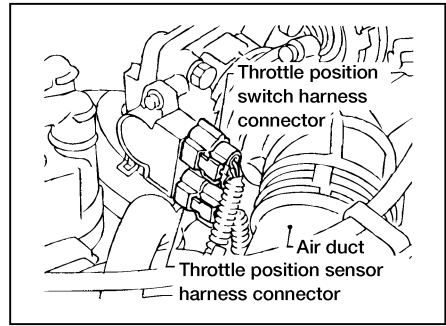
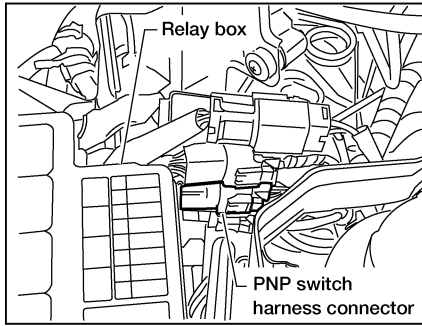
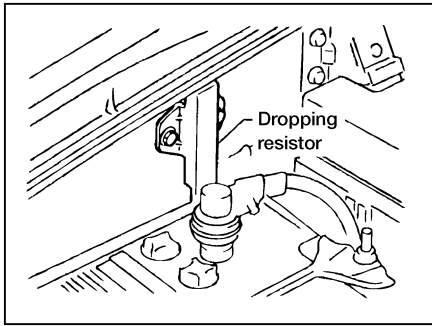

OVERALL SYSTEM

Circuit Diagram

NGAT0008

Circuit Diagram

- (AS) : With ASCD
- (VR) : With VG33ER
- (4W) : With 4-wheel drive

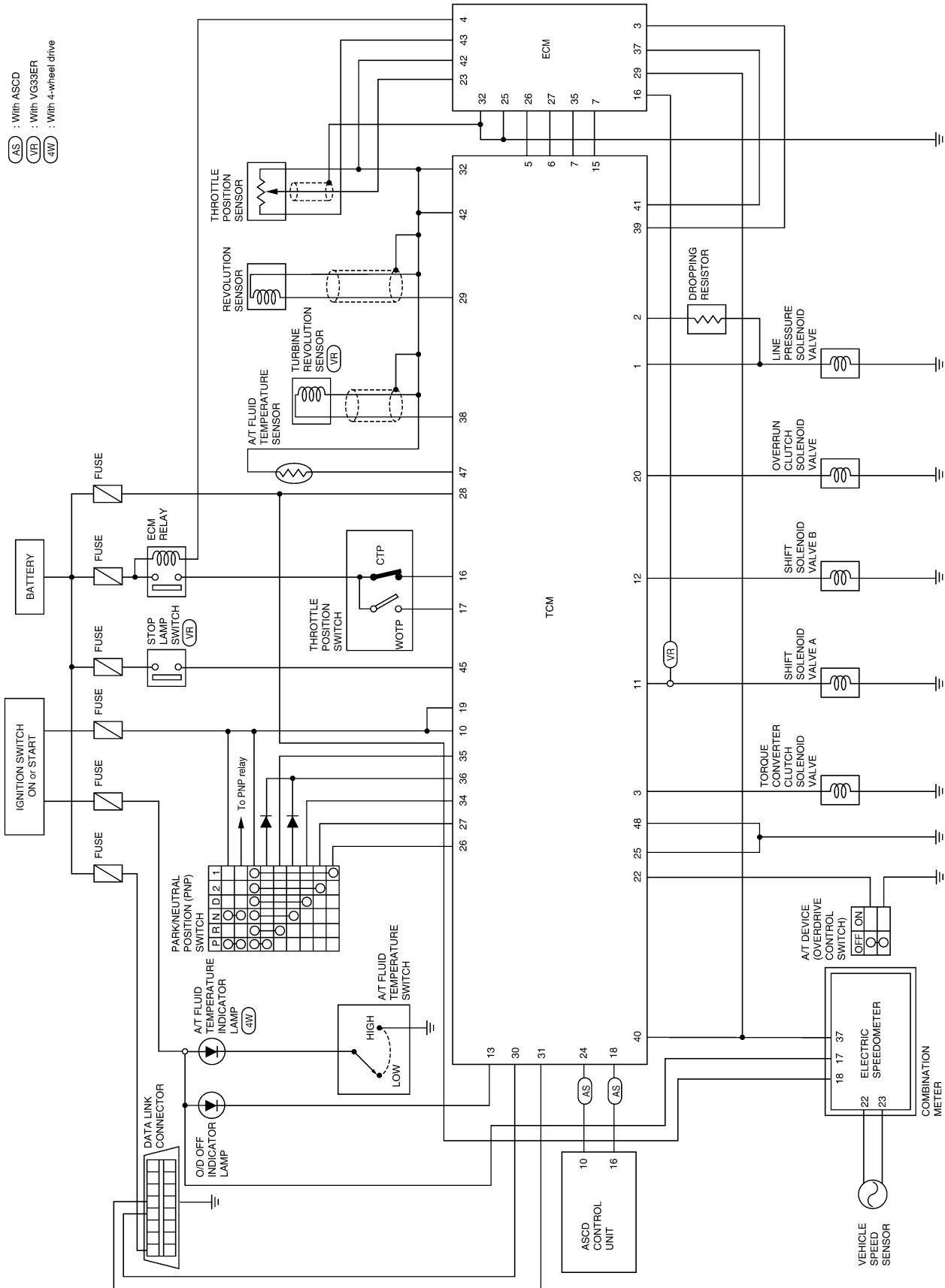

- GI
- MA
- EM
- LC
- EC
- FE
- CL
- MT
- AT**
- TF
- PD
- AX
- SU
- BR
- ST
- RS
- BT
- HA
- SC
- EL
- IDX

WAT541

OVERALL SYSTEM

Cross-sectional View

Cross-sectional View

NGAT0010

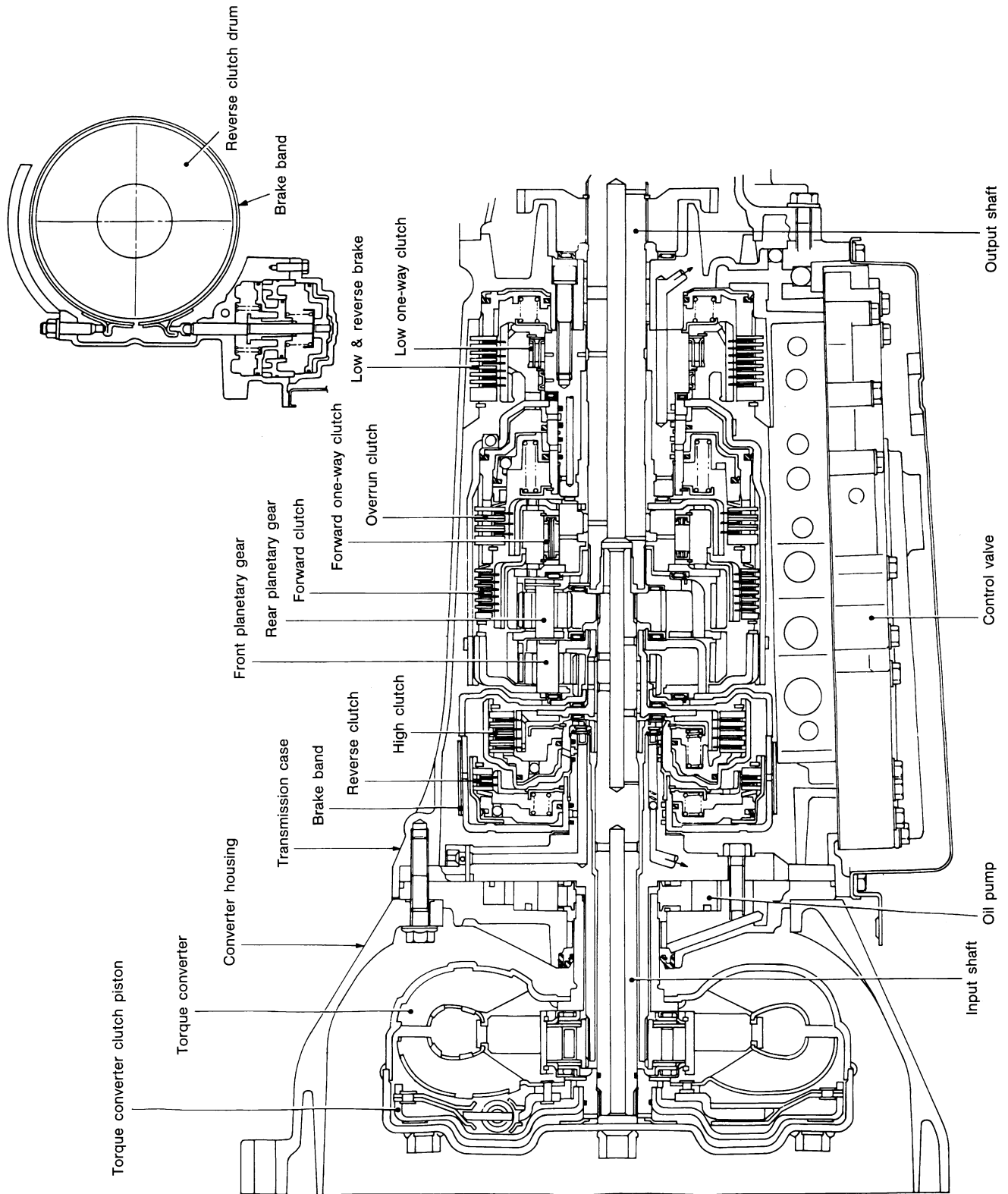

SAT125BA

OVERALL SYSTEM

Hydraulic Control Circuit

Hydraulic Control Circuit

NGAT0011

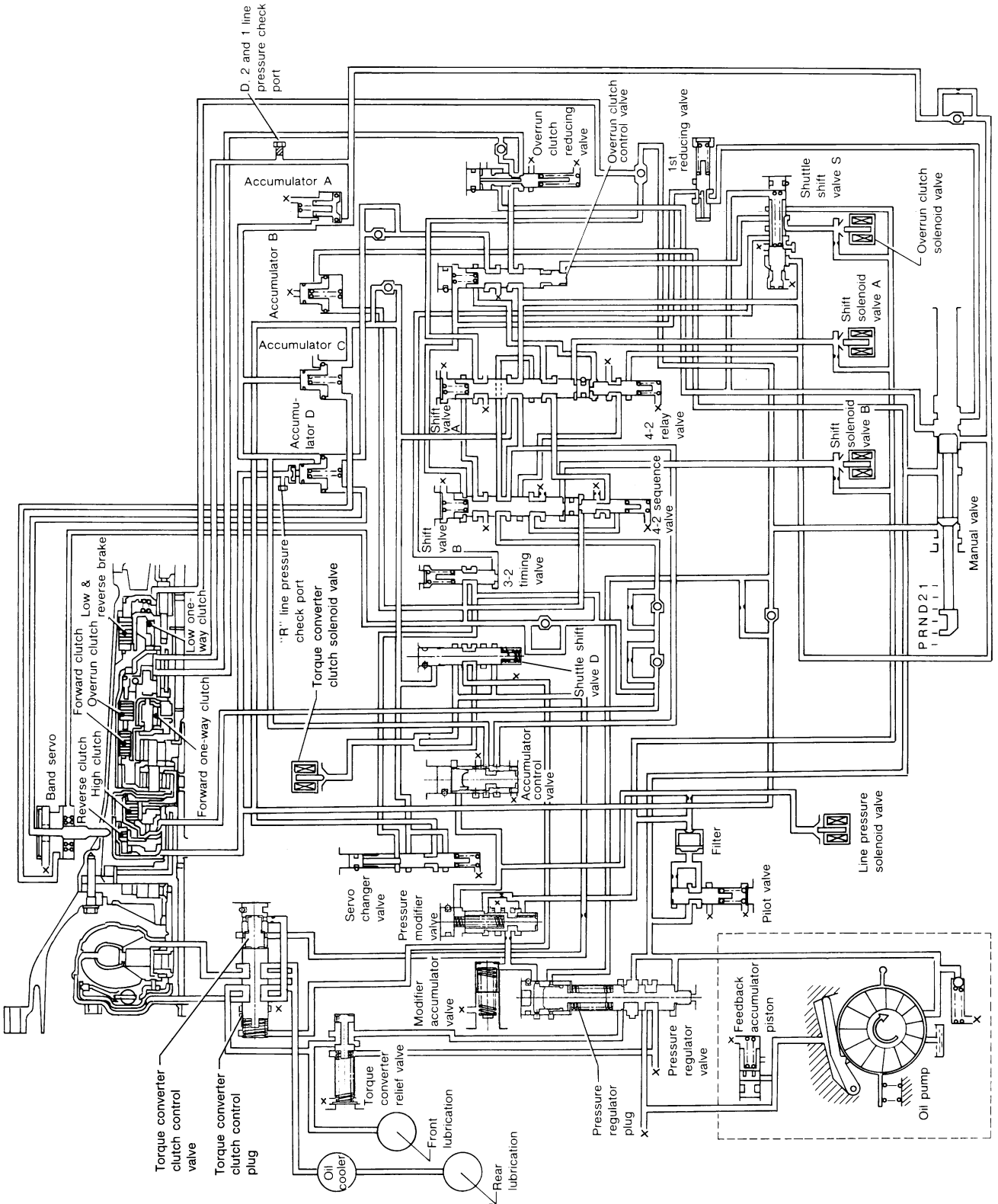

GI
MA
EM
LC
EC
FE
CL
MT
AT
TF
PD
AX
SU
BR
ST
RS
BT
HA
SC
EL
IDX

WAT371

OVERALL SYSTEM

Shift Mechanism

Shift Mechanism

NGAT0012

The automatic transmission uses compact, dual planetary gear systems to improve power-transmission efficiency, simplify construction and reduce weight.

It also employs an optimum shift control and superwide gear ratios. They improve starting performance and acceleration during medium and high-speed operation.

Two one-way clutches are also employed: one is used for the forward clutch and the other for the low clutch. These one-way clutches, combined with four accumulators, reduce shifting shock to a minimum.

CONSTRUCTION

NGAT0012S01

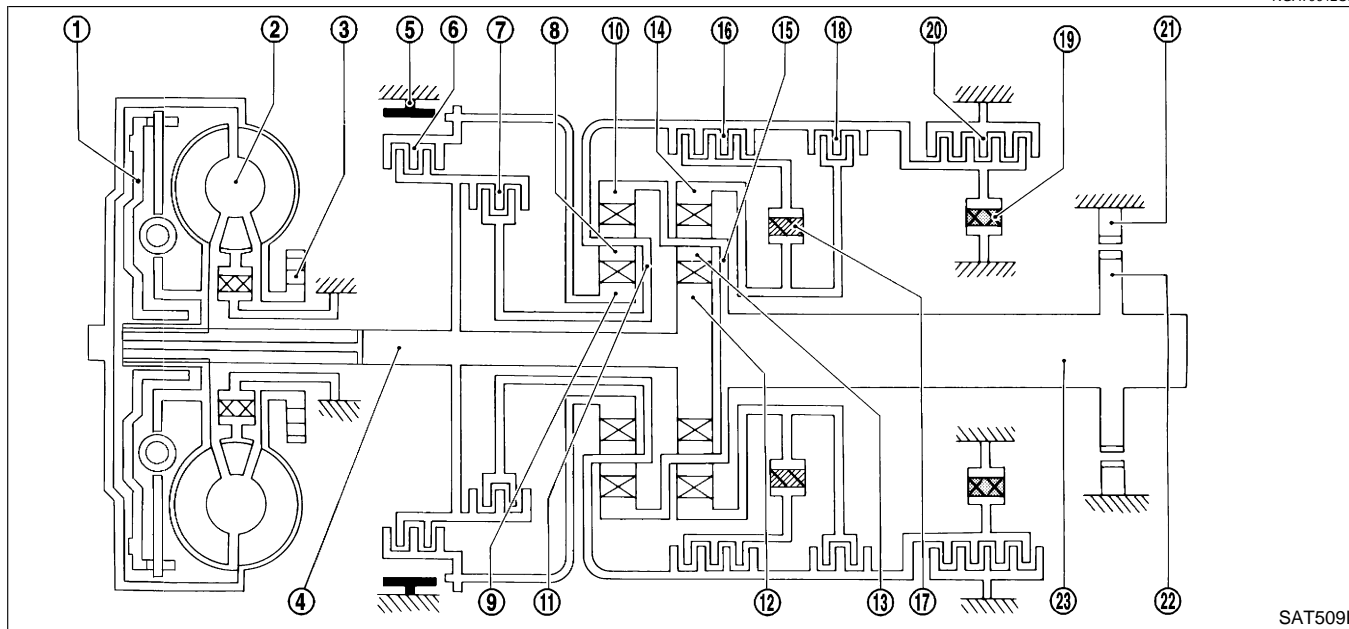

- | | | |
|-----------------------------------|-----------------------------|----------------------------|
| 1. Torque converter clutch piston | 9. Front sun gear | 17. Forward one-way clutch |
| 2. Torque converter | 10. Front internal gear | 18. Overrun clutch |
| 3. Oil pump | 11. Front planetary carrier | 19. Low one-way clutch |
| 4. Input shaft | 12. Rear sun gear | 20. Low & reverse brake |
| 5. Brake band | 13. Rear pinion gear | 21. Parking pawl |
| 6. Reverse clutch | 14. Rear internal gear | 22. Parking gear |
| 7. High clutch | 15. Rear planetary carrier | 23. Output shaft |
| 8. Front pinion gear | 16. Forward clutch | |

OVERALL SYSTEM

Shift Mechanism (Cont'd)

FUNCTION OF CLUTCH AND BRAKE

-NGAT0012S02

Clutch and brake components	Abbr.	Function
Reverse clutch 6	R/C	To transmit input power to front sun gear 9 .
High clutch 7	H/C	To transmit input power to front planetary carrier 11 .
Forward clutch 16	F/C	To connect front planetary carrier 11 with forward one-way clutch 17 .
Overrun clutch 18	O/C	To connect front planetary carrier 11 with rear internal gear 14 .
Brake band 5	B/B	To lock front sun gear 9 .
Forward one-way clutch 17	F/O.C	When forward clutch 16 is engaged, to stop rear internal gear 14 from rotating in opposite direction against engine revolution.
Low one-way clutch 19	L/O.C	To stop front planetary carrier 11 from rotating in opposite direction against engine revolution.
Low & reverse brake 20	L & R/B	To lock front planetary carrier 11 .

CLUTCH AND BAND CHART

NGAT0012S03

Shift position	Reverse clutch	High clutch	Forward clutch	Over-run clutch	Band servo			Forward one-way clutch	Low one-way clutch	Low & reverse brake	Lock-up	Remarks
					2nd apply	3rd release	4th apply					
P												PARK POSITION
R	○									○		REVERSE POSITION
N												NEUTRAL POSITION
D*4	1st		○	*1D				B	B			Automatic shift 1 ↔ 2 ↔ 3 ↔ 4
	2nd		○	*1A	○			B				
	3rd		○	○	*1A	*2C	C	B			*5○	
	4th		○	C		*3C	C	○			○	
2	1st		○	D				B	B			Automatic shift 1 ↔ 2
	2nd		○	A	○			B				
1	1st		○	○				B	B	○		Locks (held stationary) in 1st speed 1 ↔ 2
	2nd		○	○	○			B				

*1: Operates when overdrive control switch is being set in OFF position.

*2: Oil pressure is applied to both 2nd "apply" side and 3rd "release" side of band servo piston. However, brake band does not contract because oil pressure area on the "release" side is greater than that on the "apply" side.

*3: Oil pressure is applied to 4th "apply" side in condition *2 above, and brake band contracts.

*4: A/T will not shift to 4th when overdrive control switch is set in OFF position.

*5: Operates when overdrive control switch is OFF.

○ : Operates.

A: Operates when throttle opening is less than 3/16, activating engine brake.

B: Operates during "progressive" acceleration.

C: Operates but does not affect power transmission.

D: Operates when throttle opening is less than 3/16, but does not affect engine brake.

OVERALL SYSTEM

Shift Mechanism (Cont'd)

POWER TRANSMISSION

-NGAT0012S04

P and N Positions

NGAT0012S0401

- P position
Similar to the N position, no control members operate. The parking pawl interconnected with the select lever engages with the parking gear to mechanically hold the output shaft so that the power train is locked.
- N position
No control members operate. Power from the input shaft is not transmitted to the output shaft since the clutch does not operate.

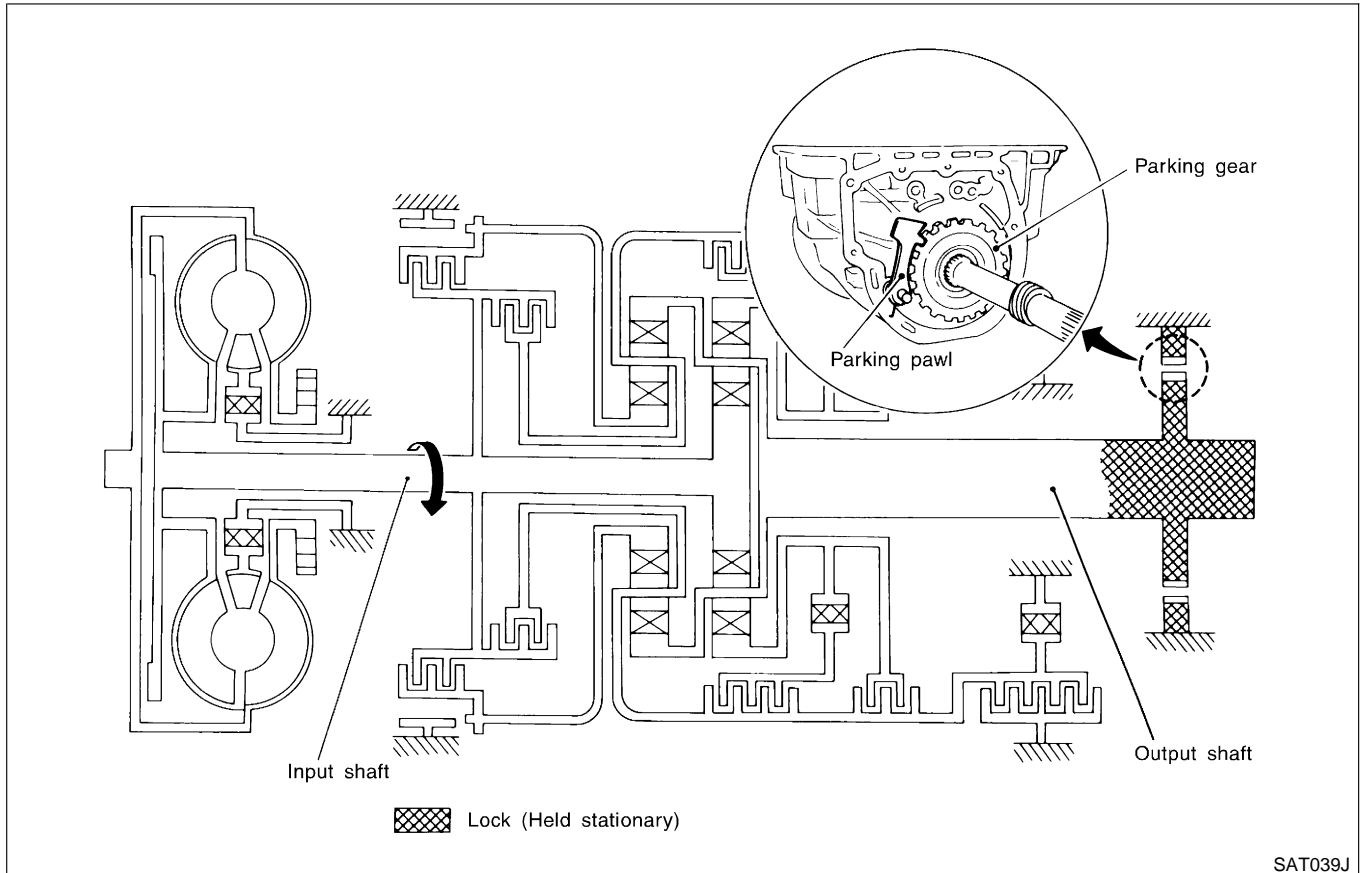

OVERALL SYSTEM

Shift Mechanism (Cont'd)

-NGAT0012S0406

1₁ Position

<p>Forward clutch Forward one-way clutch Overrun clutch Low and reverse brake</p>	<p>As overrun clutch engages, rear internal gear is locked by the operation of low and reverse brake. This is different from that of D₁ and 2₁.</p>
<p>Engine brake</p>	<p>Overrun clutch always engages, therefore engine brake can be obtained when decelerating.</p>

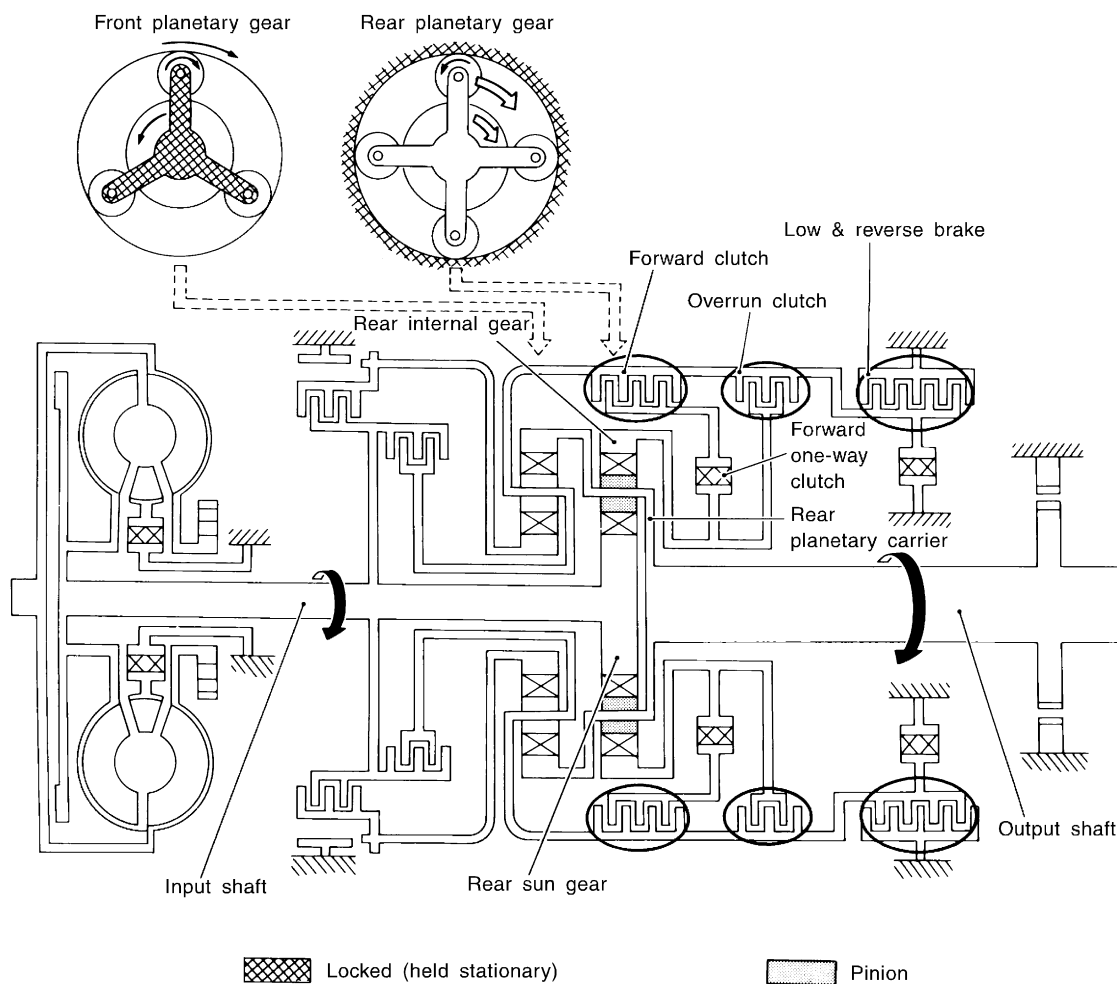

Power flow

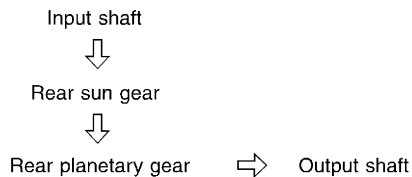

SAT100J

GI

MA

EM

LC

EC

FE

CL

MT

AT

TF

PD

AX

SU

BR

ST

RS

BT

HA

SC

EL

IDX

OVERALL SYSTEM

Shift Mechanism (Cont'd)

D₁ and 2₁ Positions

=NGAT0012S0402

<p>Forward one-way clutch Forward clutch Low one-way clutch</p>	<p>Rear internal gear is locked to rotate counterclockwise because of the functioning of these three clutches. (Start-up at D₁)</p>
<p>Overrun clutch engagement conditions (Engine brake)</p>	<p>D₁: Overdrive control switch in OFF Throttle opening less than 3/16 2₁: Throttle opening less than 3/16 At D₁ and 2₁ positions, engine brake is not activated due to free turning of low one-way clutch.</p>

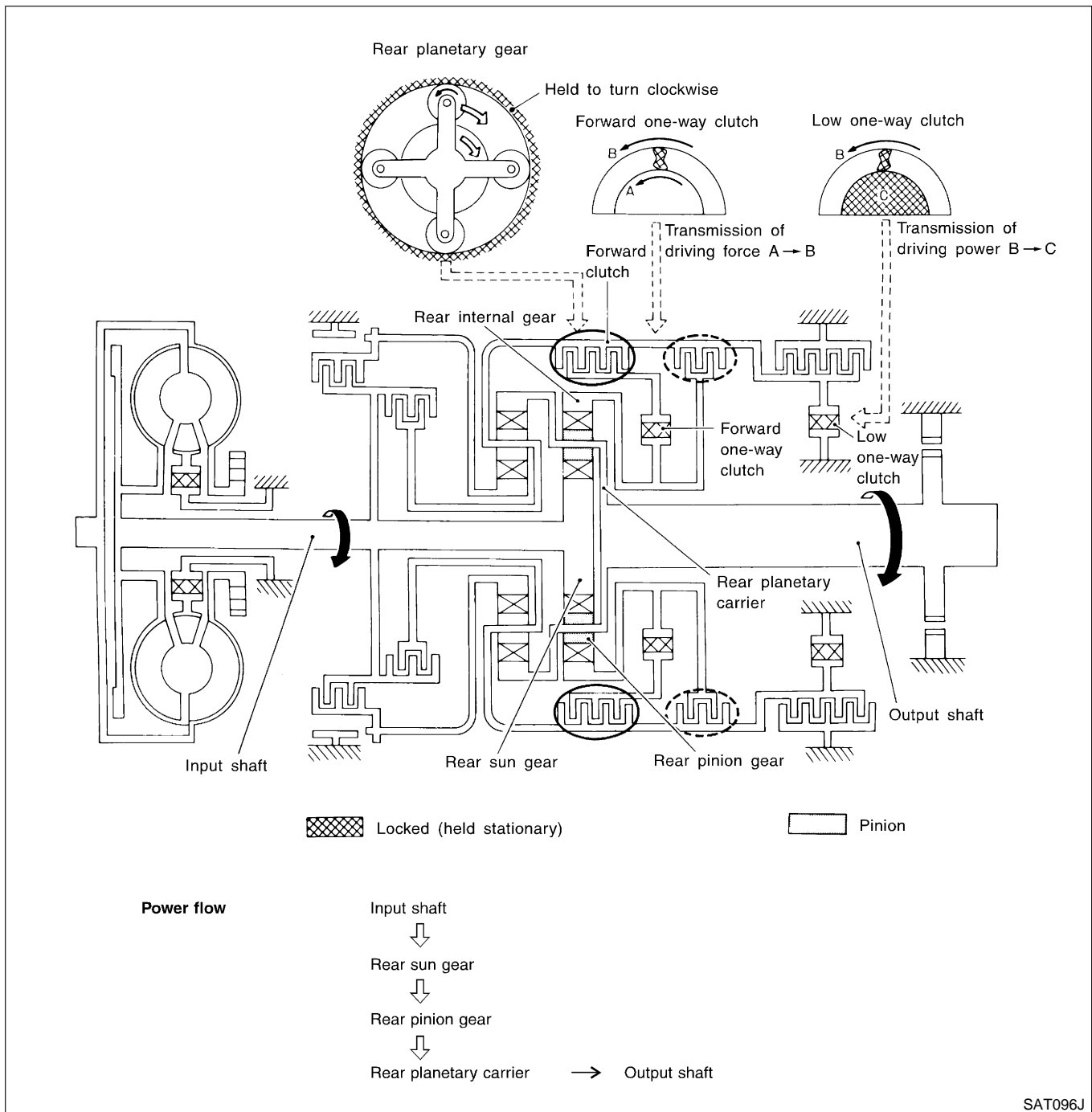

SAT096J

OVERALL SYSTEM

Shift Mechanism (Cont'd)

D₂, 2₂ and 1₂ Positions

-NGAT0012S0403

<p>Forward clutch Forward one-way clutch Brake band</p>	<p>Rear sun gear drives rear planetary carrier and combined front internal gear. Front internal gear now rotates around front sun gear accompanying front planetary carrier. As front planetary carrier transfers the power to rear internal gear through forward clutch and forward one-way clutch, this rotation of rear internal gear increases the speed of rear planetary carrier compared with that of the 1st speed.</p>
<p>Overrun clutch engagement conditions</p>	<p>D₂: Overdrive control switch in OFF Throttle opening less than 3/16 2₂: Throttle opening less than 3/16 1₂: Always engaged</p>

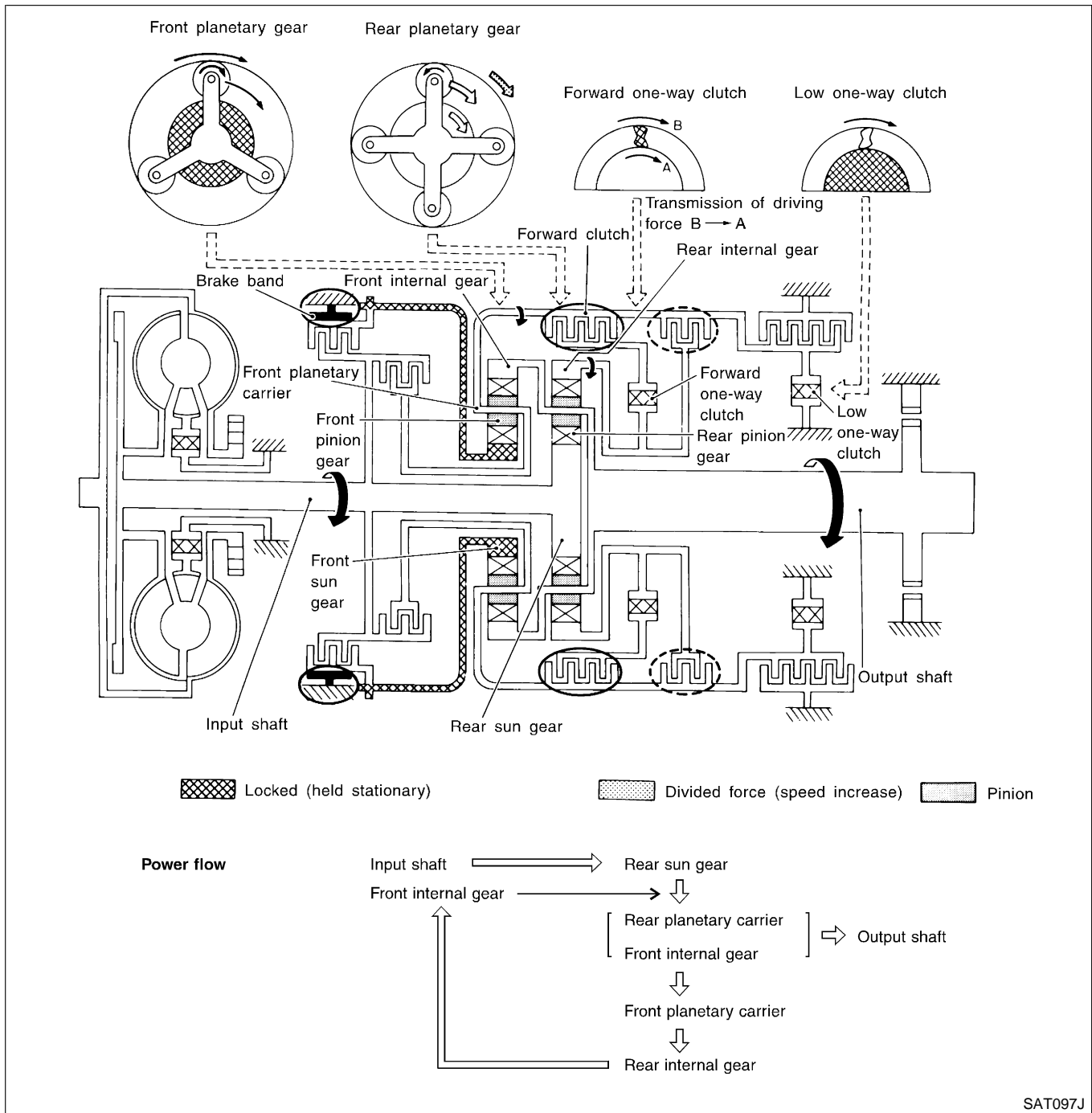

SAT097J

GI
MA
EM
LC
EC
FE
CL
MT
AT
TF
PD
AX
SU
BR
ST
RS
BT
HA
SC
EL
IDX

OVERALL SYSTEM

Shift Mechanism (Cont'd)

D₃ Position

-NGAT0012S0404

<p>High clutch Forward clutch Forward one-way clutch</p>	<p>Input power is transmitted to front planetary carrier through high clutch. And front planetary carrier is connected to rear internal gear by operation of forward clutch and forward one-way clutch. This rear internal gear rotation and another input (the rear sun gear) accompany rear planetary carrier to turn at the same speed.</p>
<p>Overrun clutch engagement conditions</p>	<p>D₃: Overdrive control switch in OFF Throttle opening less than 3/16</p>

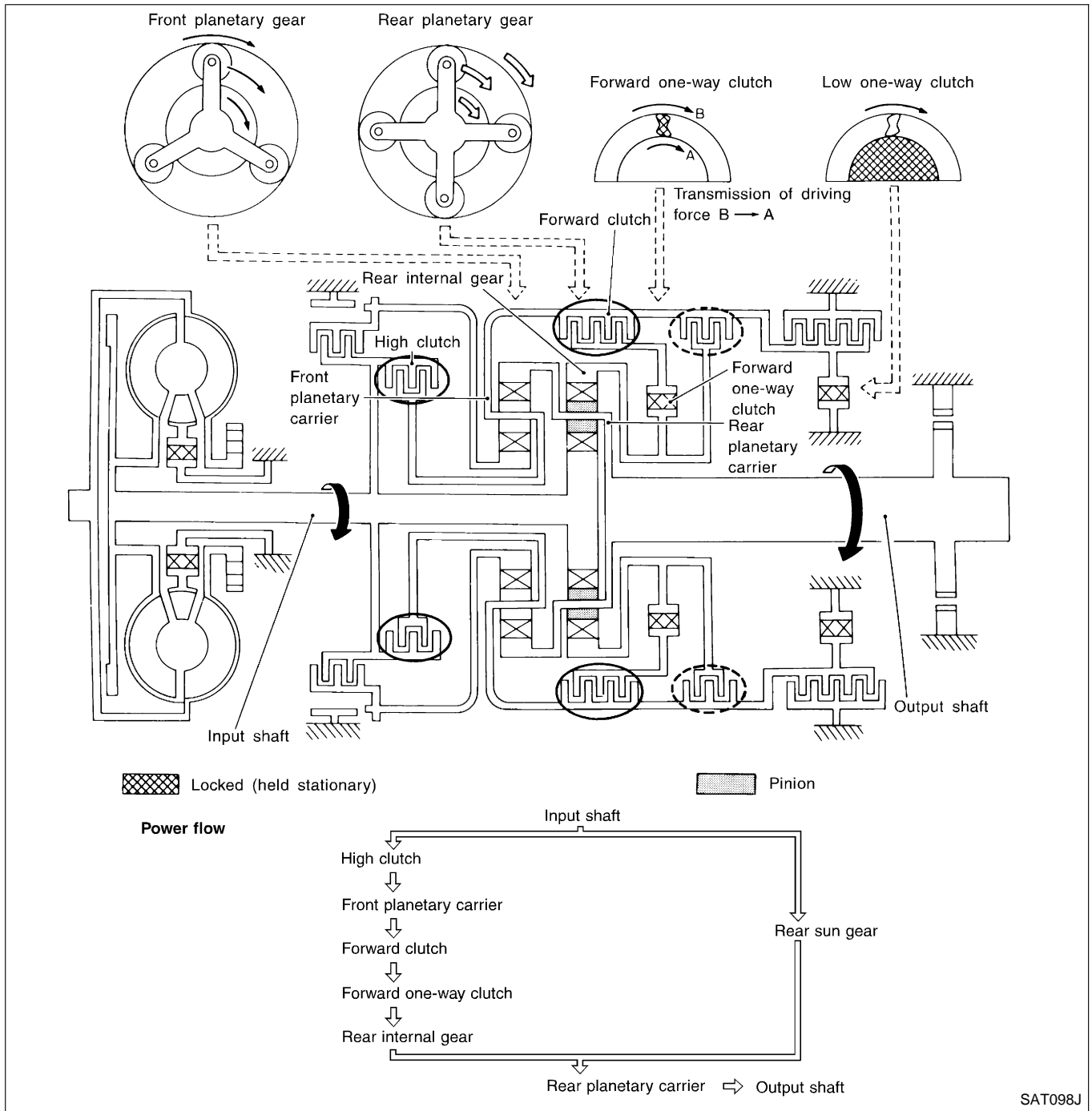

SAT098J

OVERALL SYSTEM

Shift Mechanism (Cont'd)

-NGAT0012S0405

D₄ (O/D) Position

<p>High clutch Brake band Forward clutch (Does not affect power transmission)</p>	<p>Input power is transmitted to front carrier through high clutch. This front planetary carrier turns around the sun gear which is fixed by brake band and makes front internal gear (output) turn faster.</p>	<p>GI MA EM LC EC FE CL MT AT</p>
<p>Engine brake</p>	<p>At D₄ position, there is no one-way clutch in the power transmission line and engine brake can be obtained when decelerating.</p>	<p>TF PD AX SU BR ST RS BT HA SC EL IDX</p>

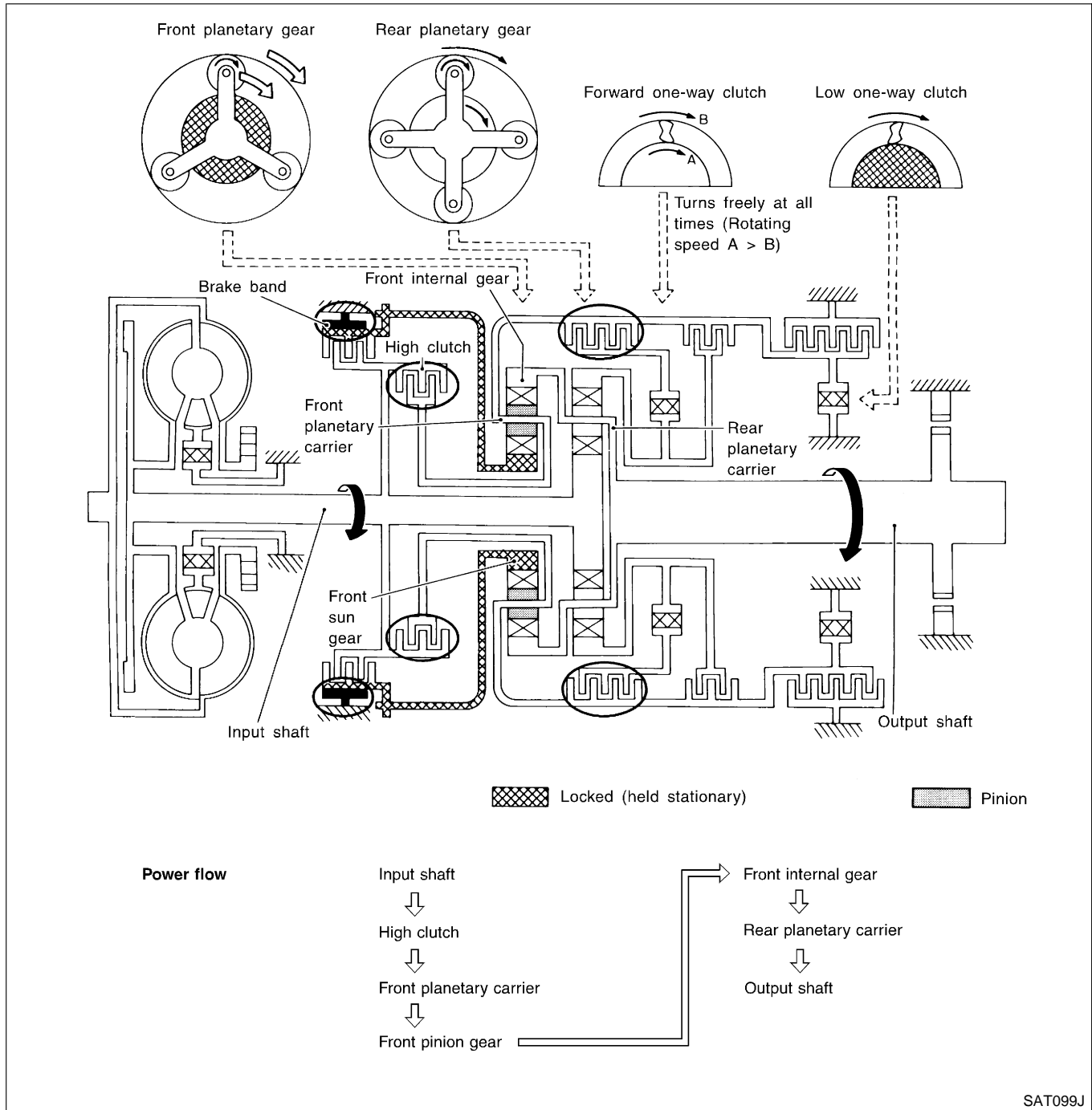

SAT099J

OVERALL SYSTEM

Shift Mechanism (Cont'd)

R Position

-NGAT0012S0407

<p>Reverse clutch Low and reverse brake</p>	<p>Front planetary carrier is stationary because of the operation of low and reverse brake. Input power is transmitted to front sun gear through reverse clutch, which drives front internal gear in the opposite direction.</p>
<p>Engine brake</p>	<p>As there is no one-way clutch in the power transmission line, engine brake can be obtained when decelerating.</p>

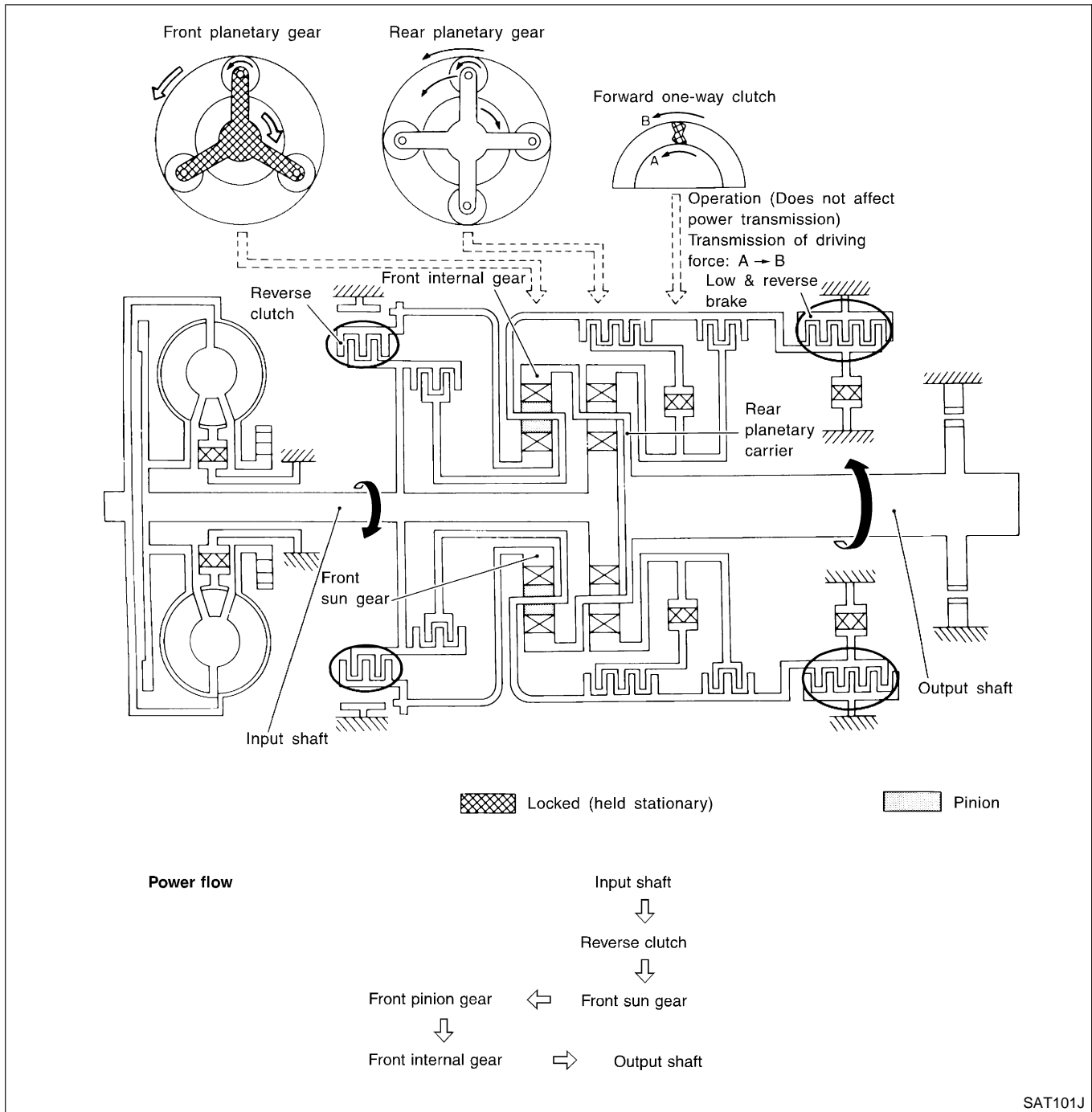

SAT101J

OVERALL SYSTEM

Control System

Control System

=NGAT0013

NGAT0013S01

OUTLINE

The automatic transmission senses vehicle operating conditions through various sensors. It always controls the optimum shift position and reduces shifting and lock-up shocks.

SENSORS		TCM		ACTUATORS
PNP switch Throttle position sensor Closed throttle position switch Wide open throttle position switch Engine speed signal A/T fluid temperature sensor Revolution sensor Vehicle speed sensor Overdrive control switch ASCD control unit Stoplamp switch (VG33ER only) Turbine revolution sensor (VG33ER only)	▶	Shift control Line pressure control Lock-up control Overrun clutch control Timing control Fail-safe control Self-diagnosis CONSULT-II communication line Duet-EA control	▶	Shift solenoid valve A Shift solenoid valve B Overrun clutch solenoid valve Torque converter clutch solenoid valve Line pressure solenoid valve O/D OFF indicator lamp

CONTROL SYSTEM

NGAT0013S02

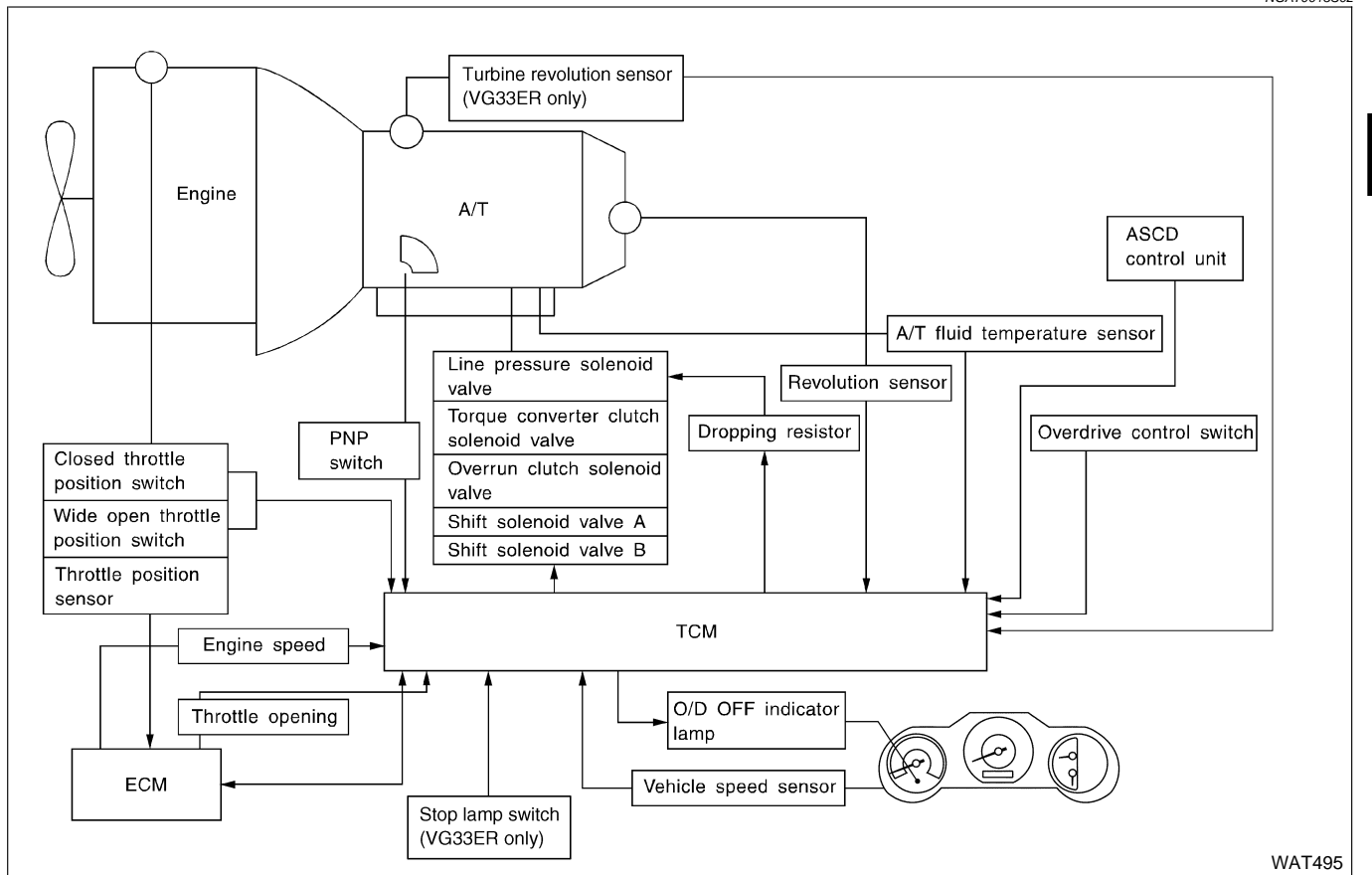

OVERALL SYSTEM

Control System (Cont'd)

TCM FUNCTION

=NGAT0013S03

The function of the TCM is to:

- Receive input signals sent from various switches and sensors.
- Determine required line pressure, shifting point, lock-up operation, and engine brake operation.
- Send required output signals to the respective solenoids.

INPUT/OUTPUT SIGNAL OF TCM

NGAT0013S04

	Sensors and solenoid valves	Function
Input	PNP switch	Detects select lever position and sends a signal to TCM.
	Throttle position sensor	Detects throttle valve position and sends a signal to TCM.
	Closed throttle position switch	Detects throttle valve's fully-closed position and sends a signal to TCM.
	Wide open throttle position switch	Detects a throttle valve position of greater than 1/2 of full throttle and sends a signal to TCM.
	Engine speed signal	From ECM.
	A/T fluid temperature sensor	Detects transmission fluid temperature and sends a signal to TCM.
	Revolution sensor	Detects output shaft rpm and sends a signal to TCM.
	Vehicle speed sensor	Used as an auxiliary vehicle speed sensor. Sends a signal when revolution sensor (installed on transmission) malfunctions.
	Overdrive control switch	Sends a signal, which prohibits a shift to "D ₄ " (overdrive) position, to the TCM.
	ASCD control unit	Sends the cruise signal and "D ₄ " (overdrive) cancellation signal from ASCD control unit to TCM.
	Turbine revolution sensor (VG33ER only)	Sends the input shaft revolution signal.
Stoplamp switch (VG33ER only)	Sends the lock-up release signal to the TCM at the time of D ₄ (lock-up).	
Output	Shift solenoid valve A/B	Selects shifting point suited to driving conditions in relation to a signal sent from TCM.
	Line pressure solenoid valve	Regulates (or decreases) line pressure suited to driving conditions in relation to a signal sent from TCM.
	Torque converter clutch solenoid valve	Regulates (or decreases) lock-up pressure suited to driving conditions in relation to a signal sent from TCM.
	Overrun clutch solenoid valve	Controls an "engine brake" effect suited to driving conditions in relation to a signal sent from TCM.
	O/D OFF indicator lamp	Shows TCM faults, when A/T control components malfunction.

Control Mechanism

NGAT0180

LINE PRESSURE CONTROL

NGAT0180S01

TCM has the various line pressure control characteristics to meet the driving conditions.

An ON-OFF duty signal is sent to the line pressure solenoid valve based on TCM characteristics.

Hydraulic pressure on the clutch and brake is electronically controlled through the line pressure solenoid valve to accommodate engine torque. This results in smooth shift operation.

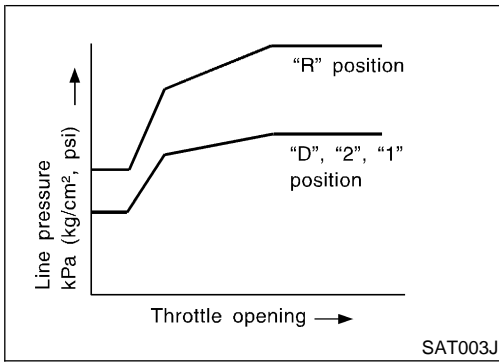

Normal Control

The line pressure to throttle opening characteristics is set for suitable clutch operation. NGAT0180S0101

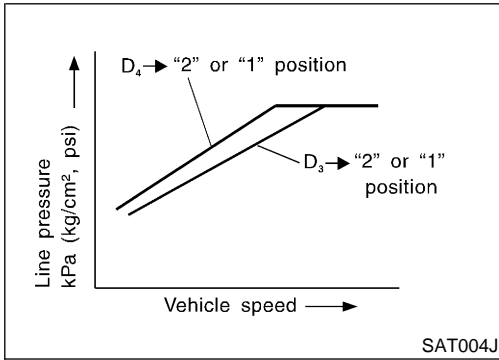

Back-up Control (Engine brake)

If the selector lever is shifted to "2" position while driving in D₄ (OD) or D₃, great driving force is applied to the clutch inside the transmission. Clutch operating pressure (line pressure) must be increased to deal with this driving force. NGAT0180S0102

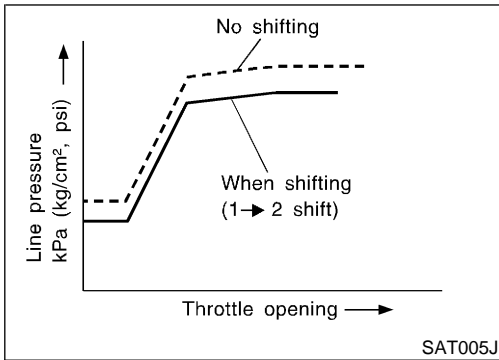

During Shift Change

The line pressure is temporarily reduced corresponding to a change in engine torque when shifting gears (that is, when the shift solenoid valve is switched for clutch operation) to reduce shifting shock. NGAT0180S0103

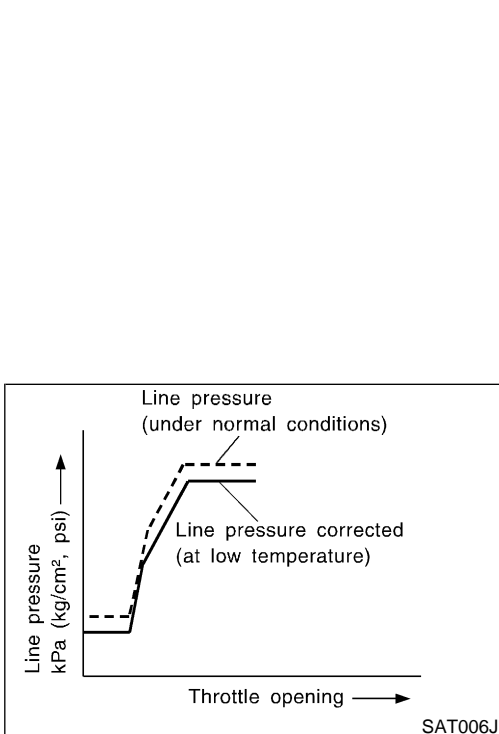

At Low Fluid Temperature

- Fluid viscosity and frictional characteristics of the clutch facing change with fluid temperature. Clutch engaging or band-contacting pressure is compensated for, according to fluid temperature, to stabilize shifting quality. NGAT0180S0104

- The line pressure is reduced below 60°C (140°F) to prevent shifting shock due to low viscosity of automatic transmission fluid when temperature is low.

GI
MA
EM
LC
EC
FE
CL
MT
AT
TF
PD
AX
SU
BR
ST
RS
BT
HA
SC
EL
IDX

OVERALL SYSTEM

Control Mechanism (Cont'd)

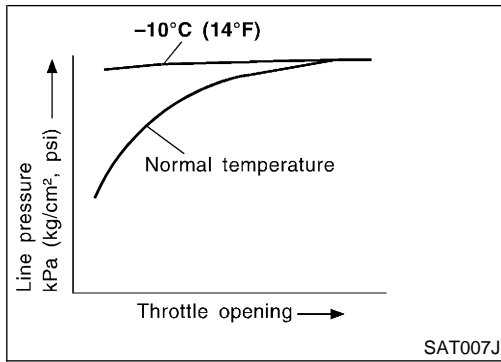

- Line pressure is increased to a maximum irrespective of the throttle opening when fluid temperature drops to -10°C (14°F). This pressure rise is adopted to prevent a delay in clutch and brake operation due to extreme drop of fluid viscosity at low temperature.

SHIFT CONTROL

NGAT0180S02

The shift is regulated entirely by electronic control to accommodate vehicle speed and varying engine operations. This is accomplished by electrical signals transmitted by the revolution sensor and throttle position sensor. This results in improved acceleration performance and fuel economy.

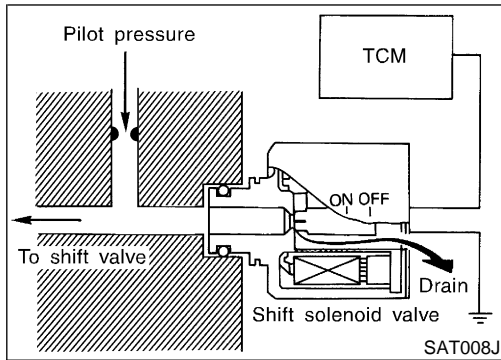

Control of Shift Solenoid Valves A and B

NGAT0180S0201

The TCM activates shift solenoid valves A and B according to signals from the throttle position sensor and revolution sensor to select the optimum gear position on the basis of the shift schedule memorized in the TCM.

The shift solenoid valve performs simple ON-OFF operation. When set to ON, the drain circuit closes and pilot pressure is applied to the shift valve.

[Relation between shift solenoid valves A and B and gear positions]

Shift solenoid valve	Gear position				
	D ₁ , 2 ₁ , 1 ₁	D ₂ , 2 ₂ , 1 ₂	D ₃	D ₄ (OD)	N-P
A	ON (Closed)	OFF (Open)	OFF (Open)	ON (Closed)	ON (Closed)
B	ON (Closed)	ON (Closed)	OFF (Open)	OFF (Open)	ON (Closed)

Control of Shift Valves A and B

NGAT0180S0202

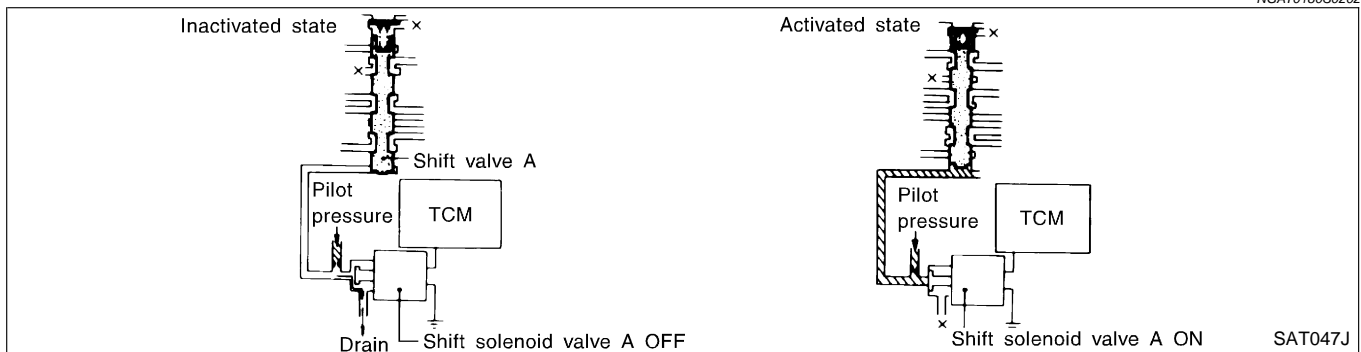

OVERALL SYSTEM

Control Mechanism (Cont'd)

Pilot pressure generated by the operation of shift solenoid valves A and B is applied to the end face of shift valves A and B.

The drawing above shows the operation of shift valve B. When the shift solenoid valve is "ON", pilot pressure applied to the end face of the shift valve overcomes spring force, moving the valve upward.

LOCK-UP CONTROL

The torque converter clutch piston in the torque converter is locked to eliminate torque converter slip to increase power transmission efficiency. The solenoid valve is controlled by an ON-OFF duty signal sent from the TCM. The signal is converted to oil pressure signal which controls the torque converter clutch piston.

Conditions for Lock-up Operation

When vehicle is driven in 4th gear position, vehicle speed and throttle opening are detected. If the detected values fall within the lock-up zone memorized in the TCM, lock-up is performed.

Overdrive control switch	ON	OFF
Selector lever	"D" position	
Gear position	D ₄	D ₃
Vehicle speed sensor	More than set value	
Throttle position sensor	Less than set opening	
Closed throttle position switch	OFF	
A/T fluid temperature sensor	More than 40°C (104°F)	

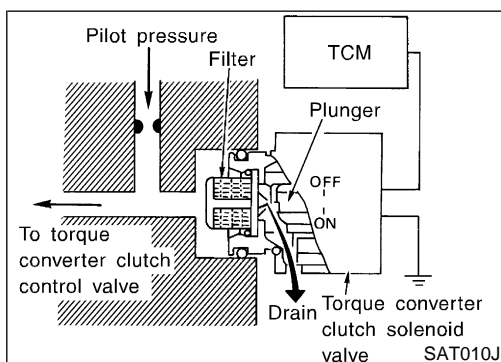

Torque Converter Clutch Solenoid Valve Control

The torque converter clutch solenoid valve is controlled by the TCM. The plunger closes the drain circuit during the OFF period, and opens the circuit during the ON period. If the percentage of OFF-time increases in one cycle, the pilot pressure drain time is reduced and pilot pressure remains high.

The torque converter clutch piston is designed to slip to adjust the ratio of ON-OFF, thereby reducing lock-up shock.

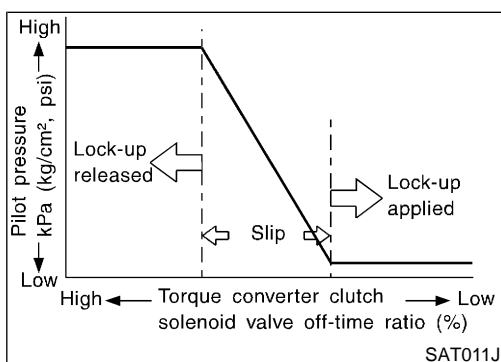

OFF-time INCREASING
 ↓
 Amount of drain DECREASING
 ↓
 Pilot pressure HIGH
 ↓
 Lock-up RELEASING

OVERALL SYSTEM

Control Mechanism (Cont'd)

Torque Converter Clutch Control Valve Operation

NGAT0180S0303

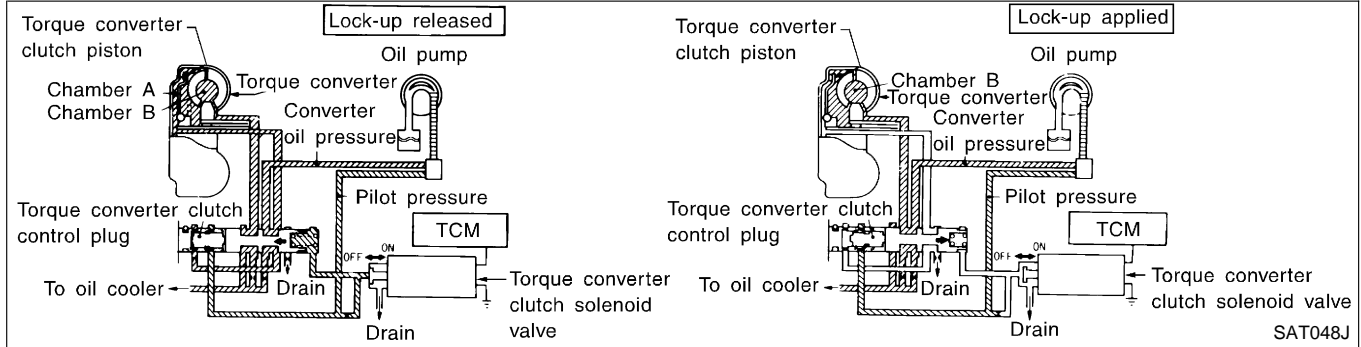

Lock-up Released

The OFF-duration of the torque converter clutch solenoid valve is long, and pilot pressure is high. The pilot pressure pushes the end face of the torque converter clutch control valve in combination with spring force to move the valve to the left. As a result, converter pressure is applied to chamber A (torque converter clutch piston release side). Accordingly, the torque converter clutch piston remains unlocked.

Lock-up Applied

When the OFF-duration of the torque converter clutch solenoid valve is short, pilot pressure drains and becomes low. Accordingly, the control valve moves to the right by the pilot pressure of the other circuit and converter pressure. As a result, converter pressure is applied to chamber B, keeping the torque converter clutch piston applied.

Also smooth lock-up is provided by transient application and release of the lock-up.

OVERRUN CLUTCH CONTROL (ENGINE BRAKE CONTROL)

NGAT0180S04

Forward one-way clutch is used to reduce shifting shocks in downshifting operations. This clutch transmits engine torque to the wheels. However, drive force from the wheels is not transmitted to the engine because the one-way clutch rotates idle. This means the engine brake is not effective.

The overrun clutch operates when the engine brake is needed.

Overrun Clutch Operating Conditions

NGAT0180S0401

	Gear position	Throttle opening
D position	D ₁ , D ₂ , D ₃ gear position	Less than 3/16
2 position	2 ₁ , 2 ₂ gear position	
1 position	1 ₁ , 1 ₂ gear position	At any position

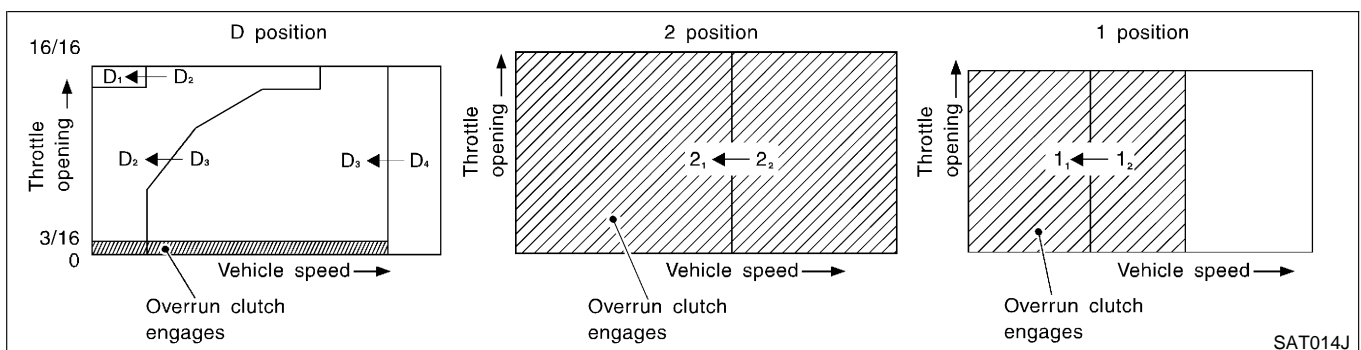

SAT014J

OVERALL SYSTEM

Control Mechanism (Cont'd)

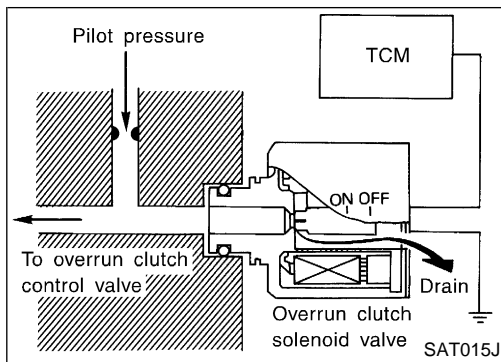

Overrun Clutch Solenoid Valve Control

NGAT0180S0402

The overrun clutch solenoid valve is operated by an ON-OFF signal transmitted by the TCM to provide overrun clutch control (engine brake control).

When this solenoid valve is ON, the pilot pressure drain port closes. When it is OFF, the drain port opens.

During the solenoid valve ON pilot pressure is applied to the end face of the overrun clutch control valve.

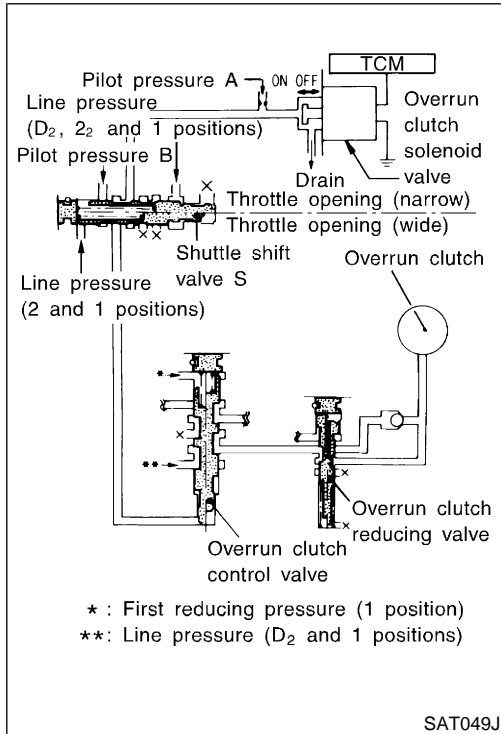

Overrun Clutch Control Valve Operation

NGAT0180S0403

When the solenoid valve is ON, pilot pressure A is applied to the overrun clutch control valve. This pushes up the overrun clutch control valve. The line pressure is then shut off so that the clutch does not engage.

When the solenoid valve is OFF, pilot pressure A is not generated. At this point, the overrun clutch control valve moves downward by spring force. As a result, overrun clutch operation pressure is provided by the overrun clutch reducing valve. This causes the overrun clutch to engage.

In the 1 position, the overrun clutch control valve remains pushed down so that the overrun clutch is engaged at all times.

Control Valve

NGAT0181

NGAT0181S01

FUNCTION OF CONTROL VALVE

Valve name	Function
<ul style="list-style-type: none"> ● Pressure regulator valve ● Pressure regulator plug ● Pressure regulator sleeve plug 	Regulate oil discharged from the oil pump to provide optimum line pressure for all driving conditions.
Pressure modifier valve	Used as a signal supplementary valve to the pressure regulator valve. Regulates pressure-modifier pressure (signal pressure) which controls optimum line pressure for all driving conditions.
Modifier accumulator piston	Smooths hydraulic pressure regulated by the pressure modifier valve to prevent pulsations.
Pilot valve	Regulates line pressure to maintain a constant pilot pressure level which controls lock-up mechanism, overrun clutch, 3-2 timing required for shifting.
Accumulator control valve Accumulator control sleeve	Regulate accumulator back-pressure to pressure suited to driving conditions.
Manual valve	Directs line pressure to oil circuits corresponding to select positions. Hydraulic pressure drains when the shift lever is in Neutral.

GI

MA

EM

LC

EC

FE

CL

MT

AT

TF

PD

AX

SU

BR

ST

RS

BT

HA

SC

EL

IDX

OVERALL SYSTEM

Control Valve (Cont'd)

Valve name	Function
Shift valve A	Simultaneously switches three oil circuits using output pressure of shift solenoid valve A to meet driving conditions (vehicle speed, throttle opening, etc.). Provides automatic downshifting and up-shifting (1st → 2nd → 3rd → 4th gears/4th → 3rd → 2nd → 1st gears) in combination with shift valve B.
Shift valve B	Simultaneously switches three oil circuits using output pressure of shift solenoid valve B in relation to driving conditions (vehicle speed, throttle opening, etc.). Provides automatic downshifting and up-shifting (1st → 2nd → 3rd → 4th gears/4th → 3rd → 2nd → 1st gears) in combination with shift valve A.
Shuttle shift valve S	Switches hydraulic circuits to provide 3-2 timing control and overrun clutch control in relation to the throttle opening. Inactivates the overrun clutch to prevent interlocking in 4th gear when the throttle is wide open.
Overrun clutch control valve	Switches hydraulic circuits to prevent engagement of the overrun clutch simultaneously with application of the brake band in 4th gear. (Interlocking occurs if the overrun clutch engages during D ₄ gear operation.)
4-2 relay valve	Memorizes that the transmission is in 4th gear. Prevents the transmission from downshifting from 4th gear to 3rd and then to 2nd in combination with 4-2 sequence valve and shift valves A and B when downshifting from 4th to 2nd gear.
4-2 sequence valve	Prevents band servo pressure from draining before high clutch operating pressure and band servo releasing pressure drain (from the same circuit) during downshifting from 4th to 2nd gear.
Servo charger valve	An accumulator and a one-way orifice are used in the 2nd gear band servo oil circuit to dampen shifting shock when shifting from 1st to 2nd gear. To maintain adequate flow rate when downshifting from 4th or 3rd gear to 2nd gear, the servo charger valve directs 2nd gear band servo hydraulic pressure to the circuit without going through the one-way orifice when downshifting from 3rd or a higher gear.
3-2 timing valve	Prevents a late operation of the brake band when shifting selector lever from D to 1 or 2 position while driving in D ₃ .
1 reducing valve	Reduces low & reverse brake pressure to dampen engine-brake shock when downshifting from the 1 position 2nd gear to 1st gear.
Overrun clutch reducing valve	Reduces oil pressure directed to the overrun clutch and prevents engine-brake shock. In 1 and 2 positions, line pressure acts on the overrun clutch reducing valve to increase the pressure-regulating point, with resultant engine brake capability.
Torque converter relief valve	Prevents an excessive rise in torque converter pressure.
Torque converter clutch control valve, torque converter clutch control plug and torque converter clutch control sleeve	Activate or inactivate the lock-up function. Also provide smooth lock-up through transient application and release of the lock-up system.
Shuttle shift valve D	Switches hydraulic circuits so that output pressure of the torque converter clutch solenoid valve acts on the lock-up valve in the D position of 2nd, 3rd and 4th gears. (In the D position 1st gear, lock-up is inhibited.) <ul style="list-style-type: none"> ● Lock-up control is not affected in D position 2nd, 3rd or 4th gears, unless output pressure of the torque converter clutch solenoid valve is generated by a signal from the control unit.

Introduction

NGAT0014

The A/T system has two self-diagnostic systems.

The first is the emission-related on board diagnostic system (OBD-II) performed by the TCM in combination with the ECM. The malfunction is indicated by the MIL (malfunction indicator lamp) and is stored as a DTC in the ECM memory but not the TCM memory.

The second is the TCM original self-diagnosis indicated by the O/D OFF indicator lamp. The malfunction is stored in the TCM memory. The detected items are overlapped with OBD-II self-diagnostic items. For detail, refer to "SELF-DIAGNOSTIC RESULT TEST MODE", AT-38.

OBD-II Function for A/T System

NGAT0182

The ECM provides emission-related on board diagnostic (OBD-II) functions for the A/T system. One function is to receive a signal from the TCM used with OBD-related parts of the A/T system. The signal is sent to the ECM when a malfunction occurs in the corresponding OBD-related part. The other function is to indicate a diagnostic result by means of the MIL (malfunction indicator lamp) on the instrument panel. Sensors, switches and solenoid valves are used as sensing elements.

The MIL automatically illuminates in One or Two Trip Detection Logic when a malfunction is sensed in relation to A/T system parts.

One or Two Trip Detection Logic of OBD-II

NGAT0015

ONE TRIP DETECTION LOGIC

NGAT0015S01

If a malfunction is sensed during the first test drive, the MIL will illuminate and the malfunction will be stored in the ECM memory as a DTC. The TCM is not provided with such a memory function.

TWO TRIP DETECTION LOGIC

NGAT0015S02

When a malfunction is sensed during the first test drive, it is stored in the ECM memory as a 1st trip DTC (diagnostic trouble code) or 1st trip freeze frame data. At this point, the MIL will not illuminate. — First Trip If the same malfunction that was experienced during the first test drive is sensed during the second test drive, the MIL will illuminate. — Second Trip

A/T-related parts for which the MIL illuminates during the first or second test drive are listed below.

Items	MIL	
	One trip detection	Two trip detection
Shift solenoid valve A — DTC: P0750 (1108)	X	
Shift solenoid valve B — DTC: P0755 (1201)	X	
Throttle position sensor or switch — DTC: P1705 (1206)	X	
Except above		X

The "trip" in the "One or Two Trip Detection Logic" means a driving mode in which self-diagnosis is performed during vehicle operation.



OBD-II Diagnostic Trouble Code (DTC)

NGAT0016

HOW TO READ DTC AND 1ST TRIP DTC

NGAT0016S01

DTC and 1st trip DTC can be read by the following methods.

( with CONSULT-II or  GST) CONSULT-II or GST (Generic Scan Tool) Examples: P0705, P0710, P0720, P0725, etc.

These DTCs are prescribed by SAE J2012.

(CONSULT-II also displays the malfunctioning component or system.)

- **1st trip DTC No. is the same as DTC No.**
- **Output of the diagnostic trouble code indicates that the indicated circuit has a malfunction. However, in case of the Mode II and GST they do not indicate whether the malfunction is still occurring or occurred in the past and returned to normal. CONSULT-II can identify them as shown below. Therefore, using CONSULT-II (if available) is recommended.**

A sample of CONSULT-II display for DTC and 1st trip DTC is shown below. DTC or 1st trip DTC of a malfunction is displayed in SELF-DIAGNOSTIC RESULTS mode for "ENGINE" with CONSULT-II. Time data indicates how many times the vehicle was driven after the last detection of a DTC.

ON BOARD DIAGNOSTIC SYSTEM DESCRIPTION

OBD-II Diagnostic Trouble Code (DTC) (Cont'd)

SELECT SYSTEM
A/T
ENGINE

SAT014K

If the DTC is being detected currently, the time data will be "0".

SELF-DIAG RESULTS	
DTC RESULTS	TIME
PNP SW/CIRC [P0705]	0

SAT015K

If a 1st trip DTC is stored in the ECM, the time data will be "[1t]".

SELF-DIAG RESULTS	
DTC RESULTS	TIME
PNP SW/CIRC [P0705]	1 t

SAT016K

Freeze Frame Data and 1st Trip Freeze Frame Data

NGAT0016S0101

The ECM has a memory function, which stores the driving condition such as fuel system status, calculated load value, engine coolant temperature, short term fuel trim, long term fuel trim, engine speed and vehicle speed at the moment the ECM detects a malfunction.

Data which are stored in the ECM memory, along with the 1st trip DTC, are called 1st trip freeze frame data, and the data, stored together with the DTC data, are called freeze frame data and displayed on CONSULT-II or GST. The 1st trip freeze frame data can only be displayed on the CONSULT-II screen, not on the GST. For detail, refer to **EC-682** (VG33E only) or **EC-1254** (VG33ER only), "CONSULT-II".

Only one set of freeze frame data (either 1st trip freeze frame data or freeze frame data) can be stored in the ECM. 1st trip freeze frame data is stored in the ECM memory along with the 1st trip DTC. There is no priority for 1st trip freeze frame data and it is updated each time a different 1st trip DTC is detected. However, once freeze frame data (2nd trip detection/MIL on) is stored in the ECM memory, 1st trip freeze frame data is no longer stored. Remember, only one set of freeze frame data can be stored in the ECM. The ECM has the following priorities to update the data.

ON BOARD DIAGNOSTIC SYSTEM DESCRIPTION

OBD-II Diagnostic Trouble Code (DTC) (Cont'd)

Priority	Items	
1	Freeze frame data	Misfire — DTC: P0300 - P0306 (0701, 0603 - 0608) Fuel Injection System Function — DTC: P0171 (0115), P0172 (0114), P0174 (0209), P0175 (0210)
2		Except the above items (Includes A/T related items)
3	1st trip freeze frame data	

Both 1st trip freeze frame data and freeze frame data (along with the DTCs) are cleared when the ECM memory is erased.

HOW TO ERASE DTC

The diagnostic trouble code can be erased by CONSULT-II, GST or ECM DIAGNOSTIC TEST MODE as described following.

- If the battery terminal is disconnected, the diagnostic trouble code will be lost within 24 hours.
- When you erase the DTC, using CONSULT-II or GST is easier and quicker than switching the mode selector on the ECM.

The following emission-related diagnostic information is cleared from the ECM memory when erasing DTC related to OBD-II. For details, refer to **EC-661** (VG33E only) or **EC-1246** (VG33ER only), "How to Erase Emission-related Diagnostic Information".

- Diagnostic trouble codes (DTC)
- 1st trip diagnostic trouble codes (1st trip DTC)
- Freeze frame data
- 1st trip freeze frame data
- System readiness test (SRT) codes
- Test values

HOW TO ERASE DTC (WITH CONSULT-II)

- If a DTC is displayed for both ECM and TCM, it needs to be erased for both ECM and TCM.
1. If the ignition switch stays ON after repair work, be sure to turn ignition switch OFF once. Wait at least 5 seconds and then turn it ON (engine stopped) again.
 2. Turn CONSULT-II ON and touch "A/T".
 3. Touch "SELF-DIAG RESULTS".
 4. Touch "ERASE". (The DTC in the TCM will be erased.) Then touch "BACK" twice.
 5. Touch "ENGINE".
 6. Touch "SELF-DIAG RESULTS".
 7. Touch "ERASE". (The DTC in the ECM will be erased.)

GI

MA

EM

LC

EC

FE

CL

MT

AT

TF

PD

AX

SU

BR

ST

RS

BT

HA

SC

EL

IDX

ON BOARD DIAGNOSTIC SYSTEM DESCRIPTION

OBD-II Diagnostic Trouble Code (DTC) (Cont'd)

How to erase DTC (With CONSULT-II)

1. If the ignition switch stays "ON" after repair work, be sure to turn ignition switch "OFF" once. Wait at least 10 seconds and then turn it "ON" (engine stopped) again.

DIAGNOSIS SYSTEM SELECTION
A/T
ENGINE



DIAGNOSIS MODE SELECTION
WORK SUPPORT
SELF DIAGNOSIS
DATA MONITOR
DTC WORK SUPPORT
TCM PART NUMBER



SELF DIAG RESULTS	
DTC RESULTS	
T/C CLUTCH SCLV	

2. Turn CONSULT-II "ON", and touch "A/T".

3. Turn "SELF DIAGNOSIS".

4. Touch "ERASE". (The DTC in the TCM will be erased.)

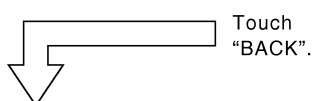

DIAGNOSIS SYSTEM SELECTION
A/T
ENGINE

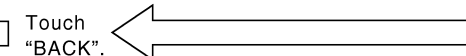

SELECT DIAG MODE
WORK SUPPORT
SELF-DIAG RESULTS
DATA MONITOR
DATA MONITOR (SPEC)
ACTIVE TEST
DTC & SRT CONFIRMATION



SELF DIAG RESULTS	
DTC RESULTS	TIME
PNP SW/CIRC [P0705]	0

5. Touch "ENGINE".

6. Touch "SELF DIAGNOSIS".

7. Touch "ERASE". (The DTC in the ECM will be erased.)

SAT286K

HOW TO ERASE DTC (WITH GST)

NGAT0016S04

1. If the ignition switch stays ON after repair work, be sure to turn ignition switch OFF once. Wait at least 5 seconds and then turn it ON (engine stopped) again.
2. Perform "OBD-II SELF-DIAGNOSTIC PROCEDURE (NO TOOLS)". Refer to "OBD-II SELF-DIAGNOSTIC PROCEDURE (NO TOOLS)", AT-46. (The engine warm-up step can be skipped when performing the diagnosis only to erase the DTC.)
3. Select Mode 4 with Generic Scan Tool (GST). For details, refer to **EC-695** (VG33E only) or **EC-1198** (VG33ER only), "Generic Scan Tool (GST)".

HOW TO ERASE DTC (NO TOOLS)

NGAT0016S05

1. If the ignition switch stays ON after repair work, be sure to turn ignition switch OFF once. Wait at least 5 seconds and then turn it ON (engine stopped) again.
2. Perform "TCM SELF-DIAGNOSTIC PROCEDURE (NO TOOLS)". Refer to "TCM SELF-DIAGNOSTIC PROCEDURE (NO TOOLS)", AT-47. (The engine warm-up step can be skipped when performing the diagnosis only to erase the DTC.)

ON BOARD DIAGNOSTIC SYSTEM DESCRIPTION

Malfunction Indicator Lamp (MIL)

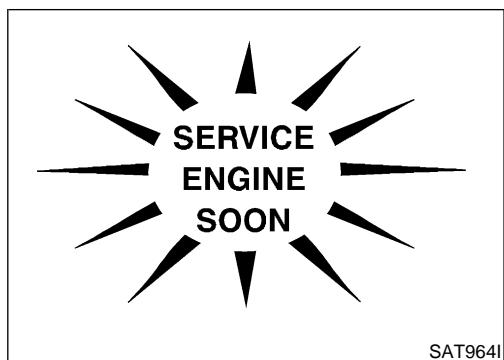

Malfunction Indicator Lamp (MIL)

NGAT0183

1. The malfunction indicator lamp will light up when the ignition switch is turned ON without the engine running. This is for checking the lamp.
 - If the malfunction indicator lamp does not light up, refer to **EL-94** "Circuit Diagram" or **EC-675** (VG33E only) or **EC-1247** (VG33ER only), "Description". (Or refer to **EC-1171** (VG33E only) or **EC-1751** (VG33ER only), "MIL & DATA LINK CONNECTORS".)
2. When the engine is started, the malfunction indicator lamp should go off.

If the lamp remains on, the on board diagnostic system has detected an emission-related (OBD-II) malfunction. For detail, refer to **EC-660** (VG33E only) or **EC-1232** (VG33ER only), "ON BOARD DIAGNOSTIC SYSTEM DESCRIPTION".

CONSULT-II

NGAT0184

After performing "SELF-DIAGNOSTIC PROCEDURE (WITH CONSULT-II)" (AT-38), place check marks for results on the "Diagnostic Worksheet", AT-57. Reference pages are provided following the items.

NOTICE:

- 1) The CONSULT-II electrically displays shift timing and lock-up timing (that is, operation timing of each solenoid). Check for time difference between actual shift timing and the CONSULT-II display. If the difference is noticeable, mechanical parts (except solenoids, sensors, etc.) may be malfunctioning. Check mechanical parts using applicable diagnostic procedures.
- 2) Shift schedule (which implies gear position) displayed on CONSULT-II and that indicated in Service Manual may differ slightly. This occurs because of the following reasons:
 - Actual shift schedule has more or less tolerance or allowance,
 - Shift schedule indicated in Service Manual refers to the point where shifts start, and
 - Gear position displayed on CONSULT-II indicates the point where shifts are completed.
- 3) Shift solenoid valve "A" or "B" is displayed on CONSULT-II at the start of shifting. Gear position is displayed upon completion of shifting (which is computed by TCM).
- 4) Additional CONSULT-II information can be found in the Operation Manual supplied with the CONSULT-II unit.

ON BOARD DIAGNOSTIC SYSTEM DESCRIPTION

CONSULT-II (Cont'd)

SELECT SYSTEM
A/T
ENGINE

SAT014K



REAL-TIME DIAG
ENG SPEED SIG

SAT987J

④ SELF-DIAGNOSTIC PROCEDURE (WITH CONSULT-II) NGAT0184S01



1. Turn on CONSULT-II and touch "ENGINE" for OBD-II detected items or touch "A/T" for TCM self-diagnosis.
If A/T is not displayed, check TCM power supply and ground circuit. Refer to "Wiring Diagram—AT—MAIN", AT-101. If result is NG, refer to **EL-10**, "POWER SUPPLY ROUTING".
2. Touch "SELF-DIAG RESULTS".
Display shows malfunction experienced since the last erasing operation.
CONSULT-II performs REAL-TIME SELF-DIAGNOSIS.
Also, any malfunction detected while in this mode will be displayed at real time.

SELF-DIAGNOSTIC RESULT TEST MODE NGAT0184S02

Detected items (Screen terms for CONSULT-II, "SELF-DIAG RESULTS" test mode)		Malfunction is detected when ...	TCM self-diagnosis	OBD-II (DTC)
"A/T"	"ENGINE"		 Available by O/D OFF indicator lamp or "A/T" on CONSULT-II	 Available by malfunction indicator lamp*2, "ENGINE" on CONSULT-II or GST
PNP switch circuit	—	● TCM does not receive the correct voltage signal (based on the gear position) from the switch.	—	P0705
—	PNP SW/CIRC			
Revolution sensor	—	● TCM does not receive the proper voltage signal from the sensor.	X	P0720
VHCL SPEED SEN-A/T	VEH SPD SEN/CIR AT			
Vehicle speed sensor (Meter)	—	● TCM does not receive the proper voltage signal from the sensor.	X	—
VHCL SPEED SEN-MTR	—			
A/T 1st gear function	—	● A/T cannot be shifted to the 1st gear position even if electrical circuit is good.	—	P0731*1
—	A/T 1ST GR FNCTN			
A/T 2nd gear function	—	● A/T cannot be shifted to the 2nd gear position even if electrical circuit is good.	—	P0732*1
—	A/T 2ND GR FNCTN			
A/T 3rd gear function	—	● A/T cannot be shifted to the 3rd gear position even if electrical circuit is good.	—	P0733*1
—	A/T 3RD GR FNCTN			



ON BOARD DIAGNOSTIC SYSTEM DESCRIPTION

CONSULT-II (Cont'd)

Detected items (Screen terms for CONSULT-II, "SELF-DIAG RESULTS" test mode)		Malfunction is detected when ...	TCM self-diagnosis	OBD-II (DTC)	
"A/T"	"ENGINE"		 Available by O/D OFF indicator lamp or "A/T" on CONSULT-II	 Available by malfunction indicator lamp*2, "ENGINE" on CON- SULT-II or GST	
A/T 4th gear function		● A/T cannot be shifted to the 4th gear position even if electrical circuit is good.	—	P0734*1	GI
—	A/T 4TH GR FNCTN				MA
A/T TCC S/V function (lock-up)		● A/T cannot perform lock-up even if electrical circuit is good.	—	P0744*1	EM
—	A/T TCC S/V FNCTN				LC
Shift solenoid valve A		● TCM detects an improper voltage drop when it tries to operate the solenoid valve.	X	P0750	EC
SHIFT SOLENOID/V A	SFT SOL A/CIRC				FE
Shift solenoid valve B		● TCM detects an improper voltage drop when it tries to operate the solenoid valve.	X	P0755	CL
SHIFT SOLENOID/V B	SFT SOL B/CIRC				MT
Overrun clutch solenoid valve		● TCM detects an improper voltage drop when it tries to operate the solenoid valve.	X	P1760	AT
OVERRUN CLUTCH S/V	O/R CLUCH SOL/ CIRC				TF
T/C clutch solenoid valve		● TCM detects an improper voltage drop when it tries to operate the solenoid valve.	X	P0740	TF
T/C CLUTCH SOL/V	TCC SOLENOID/ CIRC				PD
Line pressure solenoid valve		● TCM detects an improper voltage drop when it tries to operate the solenoid valve.	X	P0745	PD
LINE PRESSURE S/V	L/PRESS SOL/ CIRC				AX
Throttle position sensor Throttle position switch		● TCM receives an excessively low or high voltage from the sensor.	X	P1705	SU
THROTTLE POSI SEN	TP SEN/CIRC A/T				BR
Engine speed signal		● TCM does not receive the proper voltage signal from the ECM.	X	P0725	SU
ENGINE SPEED SIG					ST
A/T fluid temperature sensor		● TCM receives an excessively low or high voltage from the sensor.	X	P0710	RS
BATT/FLUID TEMP SEN	ATF TEMP SEN/ CIRC				RS
Turbine revolution sensor (VG33ER only)		● TCM does not receive the proper voltage signal from the sensor.	X	—	BT
TURBINE REV	—				HA
TCM (RAM)		● TCM memory (RAM) is malfunctioning.	—	—	HA
CONTROL UNIT (RAM)	—				SC
TCM (ROM)		● TCM memory (ROM) is malfunctioning.	—	—	EL
CONTROL UNIT (ROM)	—				EL

ON BOARD DIAGNOSTIC SYSTEM DESCRIPTION

CONSULT-II (Cont'd)

Detected items (Screen terms for CONSULT-II, "SELF-DIAG RESULTS" test mode)		Malfunction is detected when ...	TCM self-diagnosis	OBD-II (DTC)
			 Available by O/D OFF indicator lamp or "A/T" on CONSULT-II	 Available by malfunction indicator lamp*2, "ENGINE" on CONSULT-II or GST
"A/T"	"ENGINE"			
TCM EEPROM		<ul style="list-style-type: none"> TCM memory (EEPROM) is malfunctioning. 	—	—
CONT UNIT (EEPROM)	—			
Initial start		<ul style="list-style-type: none"> This is not a malfunction message (Whenever shutting off a power supply to the control unit, this message appears on the screen.) 	X	—
INITIAL START	—			
No failure (NO DTC IS DETECTED FURTHER TESTING MAY BE REQUIRED**)		<ul style="list-style-type: none"> No failure has been detected. 	X	X

X: Applicable

—: Not applicable

*1: These malfunctions cannot be displayed by MIL  if another malfunction is assigned to MIL.

*2: Refer to **EC-675** (VG33E only) or **EC-1247** (VG33ER only), "Malfunction Indicator Lamp (MIL)".

DATA MONITOR MODE (A/T)

NGAT0184S03

Item	Display	Monitor item		Description	Remarks
		TCM input signals	Main signals		
Vehicle speed sensor 1 (A/T) (Revolution sensor)	VHCL/S SE-A/T [km/h] or [mph]	X	—	<ul style="list-style-type: none"> Vehicle speed computed from signal of revolution sensor is displayed. 	When racing engine in "N" or "P" position with vehicle stationary, CONSULT-II data may not indicate 0 km/h (0 mph).
Vehicle speed sensor 2 (Meter)	VHCL/S SE-MTR [km/h] or [mph]	X	—	<ul style="list-style-type: none"> Vehicle speed computed from signal of vehicle speed sensor is displayed. 	Vehicle speed display may not be accurate under approx. 10 km/h (6 mph). It may not indicate 0 km/h (0 mph) when vehicle is stationary.
Throttle position sensor	THRTL POS SEN [V]	X	—	<ul style="list-style-type: none"> Throttle position sensor signal voltage is displayed. 	
A/T fluid temperature sensor	FLUID TEMP SE [V]	X	—	<ul style="list-style-type: none"> A/T fluid temperature sensor signal voltage is displayed. Signal voltage lowers as fluid temperature rises. 	
Battery voltage	BATTERY VOLT [V]	X	—	<ul style="list-style-type: none"> Source voltage of TCM is displayed. 	
Engine speed	ENGINE SPEED [rpm]	X	X	<ul style="list-style-type: none"> Engine speed, computed from engine speed signal, is displayed. 	Engine speed display may not be accurate under approx. 800 rpm. It may not indicate 0 rpm even when engine is not running.

ON BOARD DIAGNOSTIC SYSTEM DESCRIPTION

CONSULT-II (Cont'd)

Item	Display	Monitor item		Description	Remarks	
		TCM input signals	Main signals			
Turbine revolution sensor (VG33ER only)	TURBINE REV [rpm]	X	—	<ul style="list-style-type: none"> Turbine revolution computed from signal of turbine revolution sensor is displayed. 	Error may occur under approx. 800 rpm and will not indicate 0 rpm even if engine is not running.	GI MA EM
Overdrive control switch	OVERDRIVE SW [ON/OFF]	X	—	<ul style="list-style-type: none"> ON/OFF state computed from signal of overdrive control SW is displayed. 		LC
P/N position switch	PN POSI SW [ON/OFF]	X	—	<ul style="list-style-type: none"> ON/OFF state computed from signal of P/N position SW is displayed. 		EC
R position switch	R POSITION SW [ON/OFF]	X	—	<ul style="list-style-type: none"> ON/OFF state computed from signal of R position SW is displayed. 		FE
D position switch	D POSITION SW [ON/OFF]	X	—	<ul style="list-style-type: none"> ON/OFF state computed from signal of D position SW is displayed. 		CL
2 position switch	2 POSITION SW [ON/OFF]	X	—	<ul style="list-style-type: none"> ON/OFF status, computed from signal of 2 position SW, is displayed. 		MT
1 position switch	1 POSITION SW [ON/OFF]	X	—	<ul style="list-style-type: none"> ON/OFF status, computed from signal of 1 position SW, is displayed. 		AT TF
ASCD cruise signal	ASCD-CRUISE [ON/OFF]	X	—	<ul style="list-style-type: none"> Status of ASCD cruise signal is displayed. ON ... Cruising state OFF ... Normal running state 	<ul style="list-style-type: none"> This is displayed even when no ASCD is mounted. 	PD AX
ASCD-O/D cut signal	ASCD-O/D CUT [ON/OFF]	X	—	<ul style="list-style-type: none"> Status of ASCD O/D release signal is displayed. ON ... O/D released OFF ... O/D not released 	<ul style="list-style-type: none"> This is displayed even when no ASCD is mounted. 	SU BR
Kickdown switch	KICKDOWN SW [ON/OFF]	X	—	<ul style="list-style-type: none"> ON/OFF status, computed from signal of kickdown SW, is displayed. 	<ul style="list-style-type: none"> This is displayed even when no kickdown switch is equipped. 	ST
Closed throttle position switch	CLOSED THL/SW [ON/OFF]	X	—	<ul style="list-style-type: none"> ON/OFF status, computed from signal of closed throttle position SW, is displayed. 		RS BT
Wide open throttle position switch	W/O THRL/P-SW [ON/OFF]	X	—	<ul style="list-style-type: none"> ON/OFF status, computed from signal of wide open throttle position SW, is displayed. 		HA
Stop lamp switch (VG33ER only)	BRAKE SW [ON/OFF]	X	—	<ul style="list-style-type: none"> ON/OFF status is displayed ON...Brake pedal switch is depressed. OFF...Brake pedal switch is released. 		SC EL

ON BOARD DIAGNOSTIC SYSTEM DESCRIPTION

CONSULT-II (Cont'd)

Item	Display	Monitor item		Description	Remarks
		TCM input signals	Main signals		
Gear position	GEAR	—	X	<ul style="list-style-type: none"> ● Gear position data used for computation by TCM, is displayed. 	
Selector lever position	SLCT LVR POSI	—	X	<ul style="list-style-type: none"> ● Selector lever position data, used for computation by TCM, is displayed. 	<ul style="list-style-type: none"> ● A specific value used for control is displayed if fail-safe is activated due to error.
Vehicle speed	VEHICLE SPEED [km/h] or [mph]	—	X	<ul style="list-style-type: none"> ● Vehicle speed data, used for computation by TCM, is displayed. 	
Throttle position	THROTTLE POSI [1/8]	—	X	<ul style="list-style-type: none"> ● Throttle position data, used for computation by TCM, is displayed. 	<ul style="list-style-type: none"> ● A specific value used for control is displayed if fail-safe is activated due to error.
Line pressure duty	LINE PRES DTY [%]	—	X	<ul style="list-style-type: none"> ● Control value of line pressure solenoid valve, computed by TCM from each input signal, is displayed. 	
Torque converter clutch solenoid valve duty	TCC S/V DUTY [%]	—	X	<ul style="list-style-type: none"> ● Control value of torque converter clutch solenoid valve, computed by TCM from each input signal, is displayed. 	
Shift solenoid valve A	SHIFT S/V A [ON/OFF]	—	X	<ul style="list-style-type: none"> ● Control value of shift solenoid valve A, computed by TCM from each input signal, is displayed. 	Control value of solenoid is displayed even if solenoid circuit is disconnected. The "OFF" signal is displayed if solenoid circuit is shorted.
Shift solenoid valve B	SHIFT S/V B [ON/OFF]	—	X	<ul style="list-style-type: none"> ● Control value of shift solenoid valve B, computed by TCM from each input signal, is displayed. 	
Overrun clutch solenoid valve	OVERRUN/C S/V [ON/OFF]	—	X	<ul style="list-style-type: none"> ● Control value of overrun clutch solenoid valve computed by TCM from each input signal is displayed. 	
Self-diagnosis display lamp (O/D OFF indicator lamp)	SELF-D DP LMP [ON/OFF]	—	X	<ul style="list-style-type: none"> ● Control status of O/D OFF indicator lamp is displayed. 	

X: Applicable

—: Not applicable

ON BOARD DIAGNOSTIC SYSTEM DESCRIPTION

CONSULT-II (Cont'd)

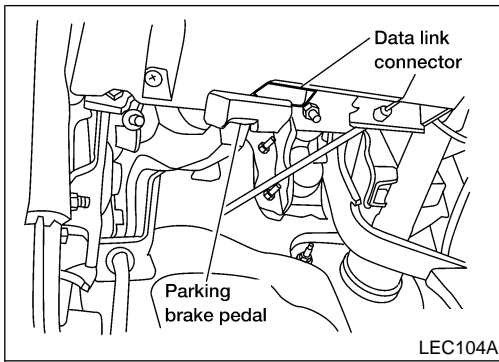

DTC WORK SUPPORT MODE WITH CONSULT-II

NGAT0184S04

CONSULT-II Setting Procedure

NGAT0184S0401

1. Turn ignition switch OFF.
2. Connect CONSULT-II to Data Link Connector. Data link connector for CONSULT-II is located in the lower instrument panel on driver side.

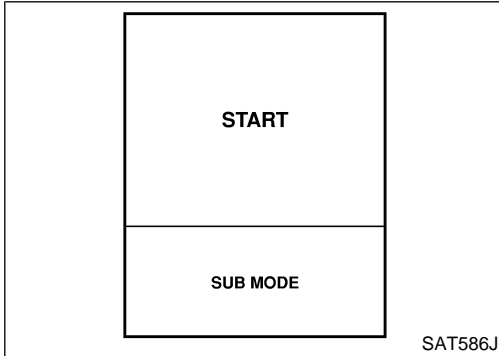

3. Turn ignition switch ON
4. Touch "START".

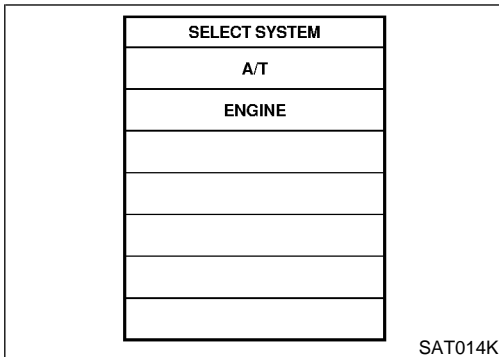

5. Touch "A/T".

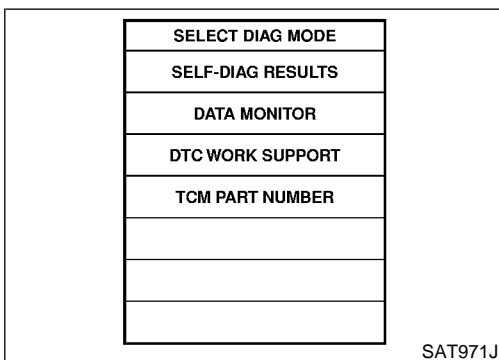

6. Touch "DTC WORK SUPPORT".

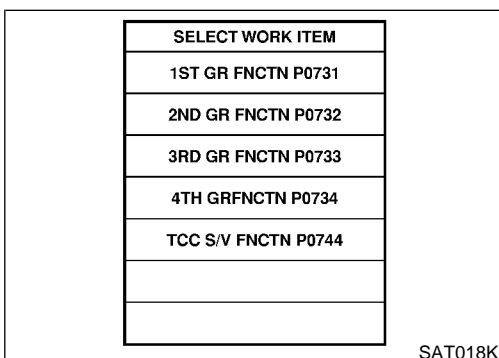

7. Touch select item menu (1ST, 2ND, etc.).

GI

MA

EM

LC

EC

FE

CL

MT

AT

TF

PD

AX

SU

BR

ST

RS

BT

HA

SC

EL

IDX

ON BOARD DIAGNOSTIC SYSTEM DESCRIPTION

CONSULT-II (Cont'd)

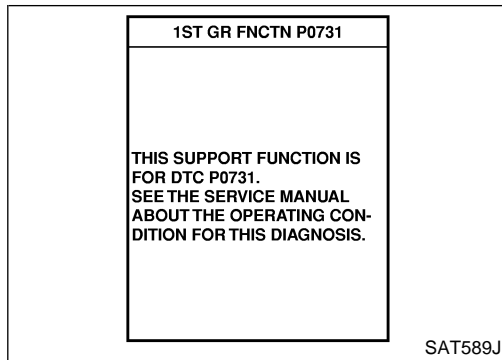

8. Touch "START".

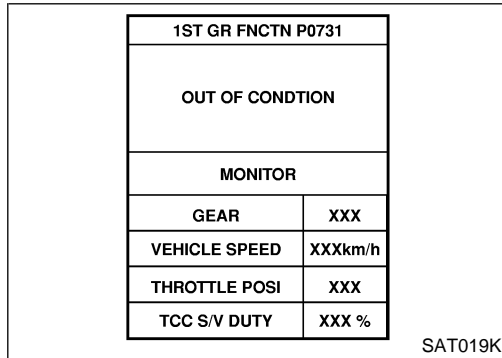

9. Perform driving test according to "DTC CONFIRMATION PROCEDURE" in "TROUBLE DIAGNOSIS FOR DTC".

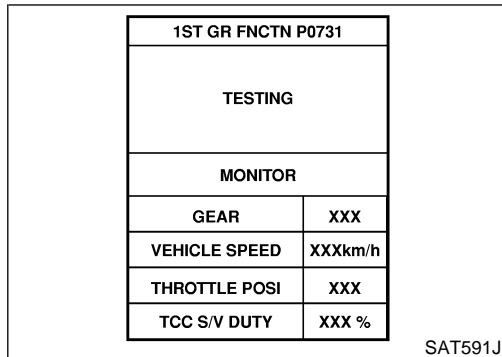

- When testing conditions are satisfied, CONSULT-II screen changes from "OUT OF CONDITION" to "TESTING".

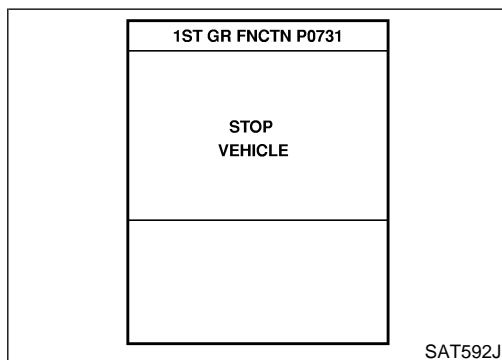

10. Stop vehicle. If "NG" appears on the screen, malfunction may exist. Go to "DIAGNOSTIC PROCEDURE".

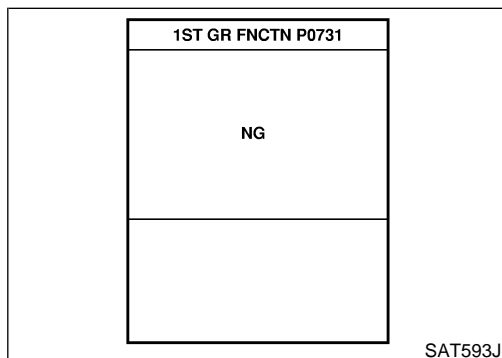

ON BOARD DIAGNOSTIC SYSTEM DESCRIPTION

CONSULT-II (Cont'd)

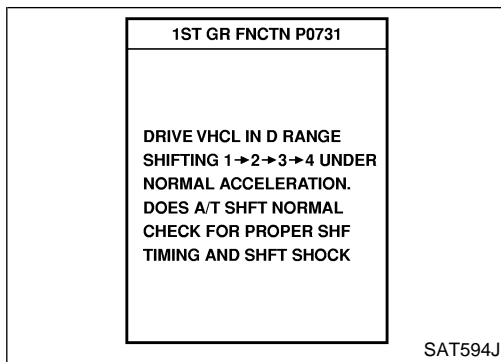

11. Perform test drive to check gear shift feeling in accordance with instructions displayed.

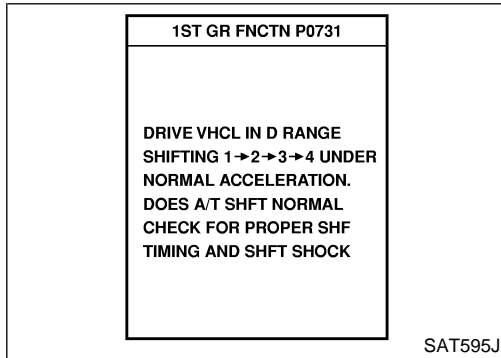

12. Touch "YES" or "NO".

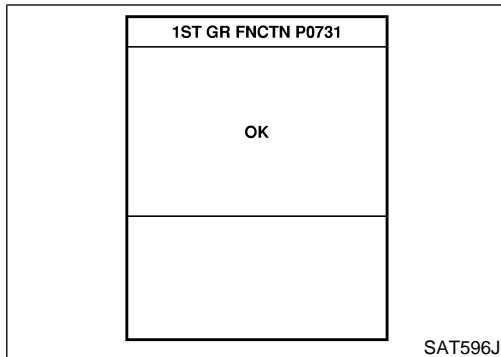

13. CONSULT-II procedure ended. If "NG" appears on the screen, a malfunction may exist. Go to "DIAGNOSTIC PROCEDURE".

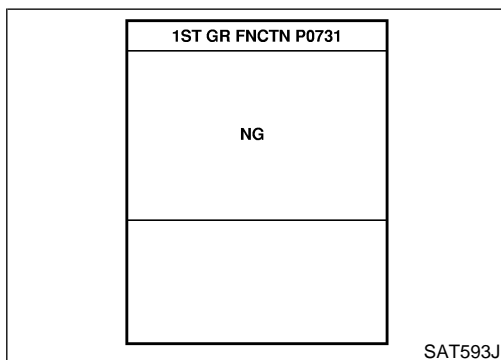

DTC WORK SUPPORT MODE

NGAT0184S05

DTC work support item	Description	Check item
1ST GR FNCTN P0731	<p>Following items for "A/T 1st gear function (P0731)" can be confirmed.</p> <ul style="list-style-type: none"> Self-diagnosis status (whether the diagnosis is being conducted or not) Self-diagnosis result (OK or NG) 	<ul style="list-style-type: none"> Shift solenoid valve A Shift solenoid valve B Each clutch Hydraulic control circuit

GI
MA
EM
LC
EC
FE
CL
MT
AT
TF
PD
AX
SU
BR
ST
RS
BT
HA
SC
EL
IDX

ON BOARD DIAGNOSTIC SYSTEM DESCRIPTION

CONSULT-II (Cont'd)

DTC work support item	Description	Check item
2ND GR FNCTN P0732	Following items for "A/T 2nd gear function (P0732)" can be confirmed. ● Self-diagnosis status (whether the diagnosis is being conducted or not) ● Self-diagnosis result (OK or NG)	<ul style="list-style-type: none"> ● Shift solenoid valve B ● Each clutch ● Hydraulic control circuit
3RD GR FNCTN P0733	Following items for "A/T 3rd gear function (P0733)" can be confirmed. ● Self-diagnosis status (whether the diagnosis is being conducted or not) ● Self-diagnosis result (OK or NG)	<ul style="list-style-type: none"> ● Shift solenoid valve A ● Each clutch ● Hydraulic control circuit
4TH GR FNCTN P0734	Following items for "A/T 4th gear function (P0734)" can be confirmed. ● Self-diagnosis status (whether the diagnosis is being conducted or not) ● Self-diagnosis result (OK or NG)	<ul style="list-style-type: none"> ● Shift solenoid valve A ● Shift solenoid valve B ● Overrun clutch solenoid valve ● Line pressure solenoid valve ● Each clutch ● Hydraulic control circuit
TCC S/V FNCTN P0744	Following items for "A/T TCC S/V function (lock-up) (P0744)" can be confirmed. ● Self-diagnosis status (whether the diagnosis is being conducted or not) ● Self-diagnosis result (OK or NG)	<ul style="list-style-type: none"> ● Torque converter clutch solenoid valve ● Each clutch ● Hydraulic control circuit

Diagnostic Procedure Without CONSULT-II

OBD-II SELF-DIAGNOSTIC PROCEDURE (WITH GST) ^{NGAT0207}
 Refer to **EC-695** (VG33E only) or **EC-1267** (VG33ER only), "Generic Scan Tool (GST)". ^{NGAT0207S01}

OBD-II SELF-DIAGNOSTIC PROCEDURE (NO TOOLS)
 Refer to **EC-675** (VG33E only) or **EC-1247** (VG33ER only), "Malfunction Indicator Lamp (MIL)". ^{NGAT0207S02}

ON BOARD DIAGNOSTIC SYSTEM DESCRIPTION

Diagnostic Procedure Without CONSULT-II (Cont'd)



TCM SELF-DIAGNOSTIC PROCEDURE (NO TOOLS)

NGAT0207S03

1	CHECK O/D OFF INDICATOR LAMP		
		<p>1. Selector lever in P position. Start the engine. Warm engine to normal operating temperature.</p> <p>2. Turn ignition switch to OFF position.</p> <p>3. Wait at least 5 seconds.</p> <div style="text-align: center;"> <p>OVERDRIVE ON/OFF →</p> <p>P</p> </div> <p>4. Turn ignition switch to ON position. (Do not start engine.)</p> <p>5. Does O/D OFF indicator lamp come on for about 2 seconds?</p> <div style="text-align: center;"> <p>O/D OFF indicator lamp</p> </div> <p style="text-align: center;">Yes or No</p>	<p>SAT9671</p> <p>WAT496</p>
	Yes	▶ GO TO 2.	
	No	▶ Go to "1. O/D OFF Indicator Lamp Does Not Come On", AT-215.	

GI
MA
EM
LC
EC
FE
CL
MT
AT
TF
PD
AX
SU
BR
ST
RS
BT
HA
SC
EL
IDX

ON BOARD DIAGNOSTIC SYSTEM DESCRIPTION

Diagnostic Procedure Without CONSULT-II (Cont'd)

2 JUDGEMENT PROCEDURE STEP 1

1. Turn ignition switch to OFF position.
2. Turn ignition switch to ACC position.
3. Move selector lever from P to D position.
4. Turn ignition switch to ON position. Do not start engine.
5. Depress and hold overdrive control switch in OFF position (the O/D OFF indicator lamp will be ON) until directed to release the switch. If O/D OFF indicator lamp does not come on, go to step 3 in test no. 3 "DIAGNOSTIC PROCEDURE" (AT-253).
6. Turn ignition switch to OFF position.

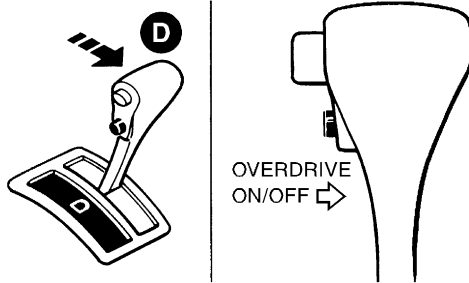

SAT968I

7. Turn ignition switch to ON position (Do not start engine).
8. Release the overdrive control switch (the O/D OFF indicator lamp will be OFF).
 - Wait for more than 2 seconds after ignition switch ON.
9. Move selector lever to 2 position.
10. Depress and release the overdrive control switch (the O/D OFF indicator lamp will be ON).
11. Depress and hold the overdrive control switch (the O/D OFF indicator lamp will be OFF) until directed to release the switch.

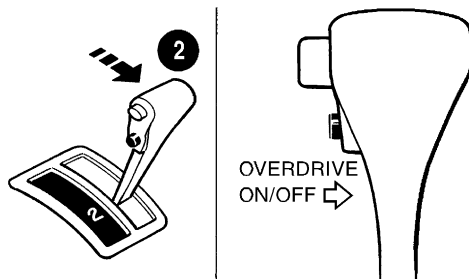

SAT969I

▶ GO TO 3.

ON BOARD DIAGNOSTIC SYSTEM DESCRIPTION

Diagnostic Procedure Without CONSULT-II (Cont'd)

3 JUDGEMENT PROCEDURE STEP 2

1. Move selector lever to 1 position.
2. Release the overdrive control switch.
3. Depress and release the overdrive control switch (the O/D OFF indicator lamp will be ON).
4. Depress and release the overdrive control switch (the O/D OFF indicator lamp will be OFF).
5. Depress and hold the overdrive control switch (the O/D OFF indicator lamp will be ON) until directed to release the switch.

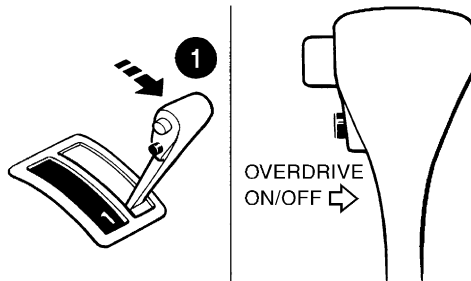

SAT970I

6. Depress accelerator pedal fully and release.
7. Release the overdrive control switch (the O/D OFF indicator lamp will begin to flash ON and OFF).

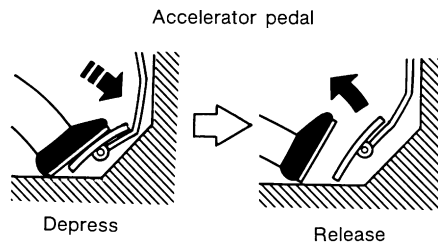

SAT981F

▶ GO TO 4.

4 CHECK SELF-DIAGNOSIS CODE

Check O/D OFF indicator lamp.
Refer to "JUDGEMENT OF SELF-DIAGNOSIS CODE", AT-50.

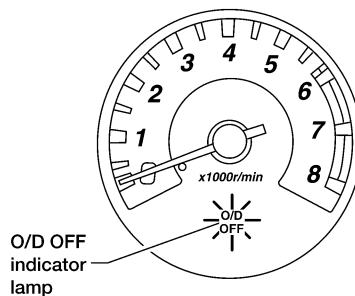

WAT496

▶ DIAGNOSIS END

GI
MA
EM
LC
EC
FE
CL
MT
AT
TF
PD
AX
SU
BR
ST
RS
BT
HA
SC
EL
IDX

ON BOARD DIAGNOSTIC SYSTEM DESCRIPTION

Diagnostic Procedure Without CONSULT-II (Cont'd)

JUDGEMENT OF SELF-DIAGNOSIS CODE (VG33E ONLY)

NGAT0207S04

O/D OFF indicator lamp:

All judgement flickers are same.

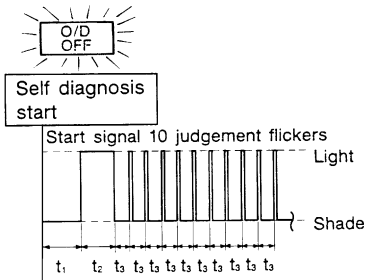

SAT436F

All circuits that can be confirmed by self-diagnosis are OK.

1st judgement flicker is longer than others.

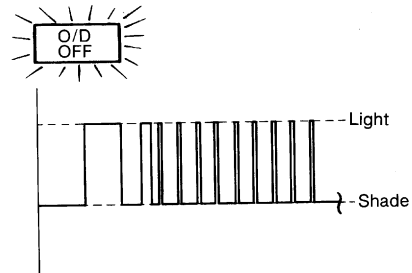

SAT437F

Revolution sensor circuit is short-circuited or disconnected.

⇒ Go to **VEHICLE SPEED SENSOR-A/T (REVOLUTION SENSOR)** , AT-116.

2nd judgement flicker is longer than others.

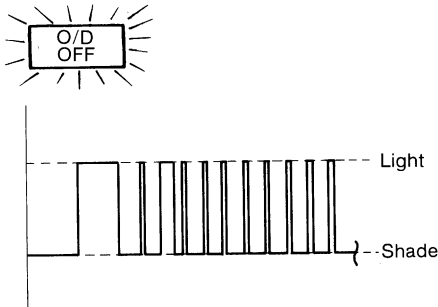

SAT439F

Vehicle speed sensor circuit is short-circuited or disconnected.

⇒ Go to **VEHICLE SPEED SENSOR-MTR**, AT-199.

3rd judgement flicker is longer than others.

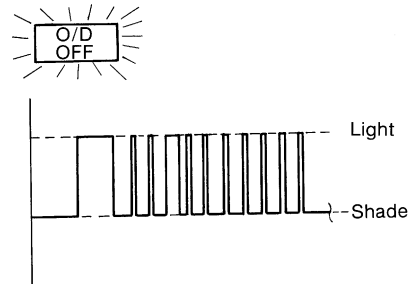

SAT441F

Throttle position sensor circuit is short-circuited or disconnected.

⇒ Go to **THROTTLE POSITION SENSOR** , AT-179.

4th judgement flicker is longer than others.

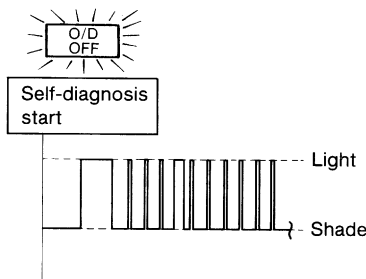

SAT443F

Shift solenoid valve A circuit is short-circuited or disconnected.

⇒ Go to **SHIFT SOLENOID VALVE A** , AT-169.

5th judgement flicker is longer than others.

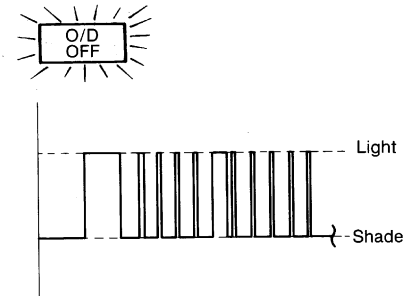

SAT445F

Shift solenoid valve B circuit is short-circuited or disconnected.

⇒ Go to **SHIFT SOLENOID VALVE B** , AT-174.

ON BOARD DIAGNOSTIC SYSTEM DESCRIPTION

Diagnostic Procedure Without CONSULT-II (Cont'd)

O/D OFF indicator lamp:

6th judgement flicker is longer than others.

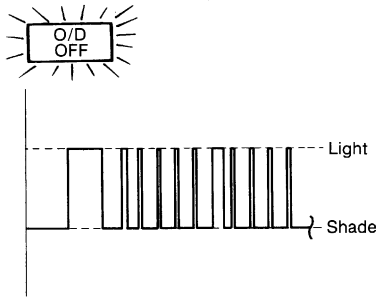

SAT447F

Overrun clutch solenoid valve circuit is short-circuited or disconnected.

⇒ Go to **VERRUN CLUTCH SOLENOID VALVE (DTC: 1203)**, AT-188.

7th judgement flicker is longer than others.

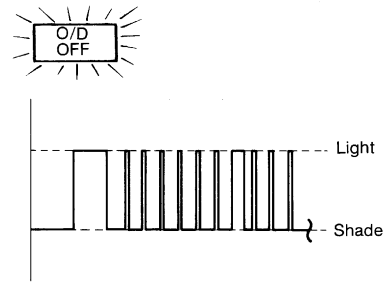

SAT449F

Torque converter clutch solenoid valve circuit is short-circuited or disconnected.

⇒ Go to **TORQUE CONVERTER CLUTCH SOLENOID VALVE**, AT-152.

8th judgement flicker is longer than others.

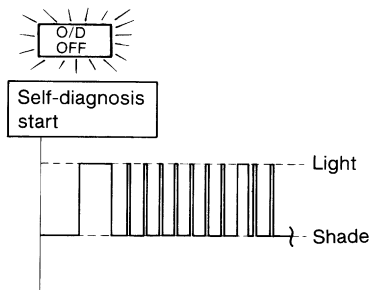

SAT451F

A/T fluid temperature sensor is disconnected or TCM power source circuit is damaged.

⇒ Go to **A/T FLUID TEMPERATURE SENSOR AND TCM POWER SOURCE**, AT-193.

9th judgement flicker is longer than others.

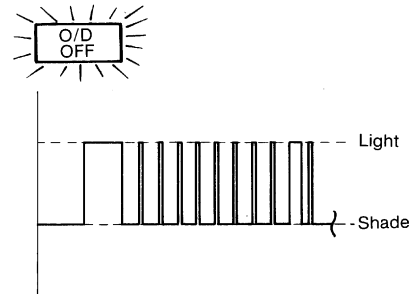

SAT453F

Engine speed signal circuit is short-circuited or disconnected.

⇒ Go to **ENGINE SPEED SIGNAL** AT-121.

10th judgement flicker is longer than others.

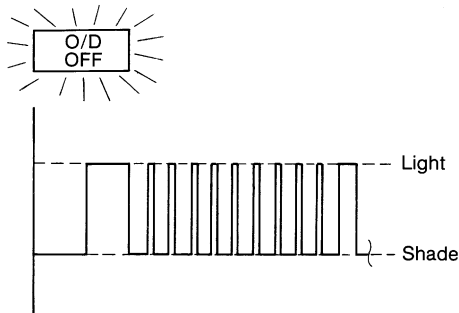

SAT455F

Line pressure solenoid valve circuit is short-circuited or disconnected.

⇒ Go to **LINE PRESSURE SOLENOID VALVE**, AT-164.

Flickers as shown below.

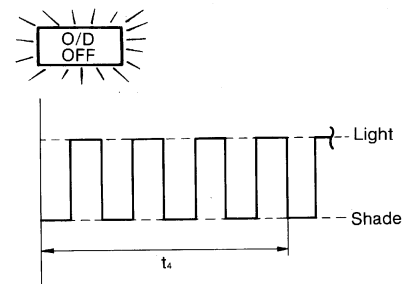

SAT457F

Battery power is low.

Battery has been disconnected for a long time.

Battery is connected conversely.

(When reconnecting TCM connectors. — This is not a problem.)

GI

MA

EM

LC

EC

FE

CL

MT

AT

TF

PD

AX

SU

BR

ST

RS

BT

HA

SC

EL

IDX

ON BOARD DIAGNOSTIC SYSTEM DESCRIPTION

Diagnostic Procedure Without CONSULT-II (Cont'd)

O/D OFF indicator lamp:

Lamp comes on.

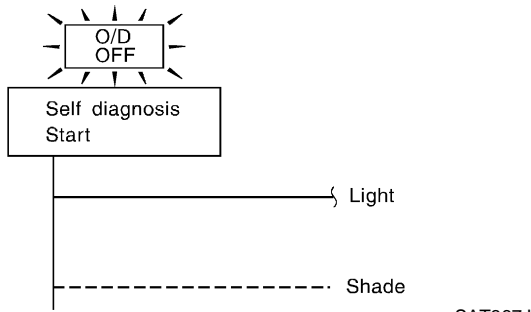

PNP switch, overdrive control switch or throttle position switch circuit is disconnected or TCM is damaged.

⇒ Go to 21. TCM Self-diagnosis Does Not Activate PNP, OVERDRIVE CONTROL AND THROTTLE POSITION SWITCHES), AT-252.

$t_1 = 2.5$ seconds $t_2 = 2.0$ seconds $t_3 = 1.0$ second $t_4 = 1.0$ second

JUDGEMENT OF SELF-DIAGNOSIS CODE (VG33ER ONLY)

NGAT0207S05

O/D OFF indicator lamp:

All judgement flickers are same.

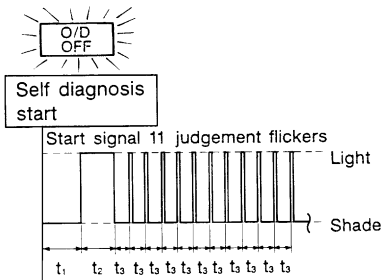

LAT425

All circuits that can be confirmed by self-diagnosis are OK.

1st judgement flicker is longer than others.

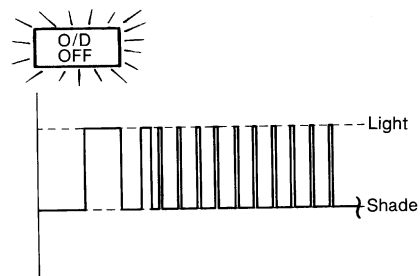

LAT426

Revolution sensor circuit is short-circuited or disconnected.

⇒ Go to "DTC P0720 VEHICLE SPEED SENSOR-A/T (REVOLUTION SENSOR)", AT-116.

2nd judgement flicker is longer than others.

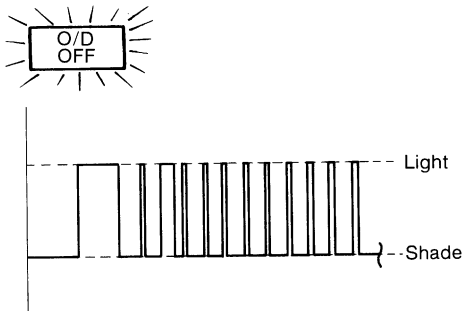

LAT427

Vehicle speed sensor circuit is short-circuited or disconnected.

⇒ Go to "DTC VEHICLE SPEED SENSOR-MTR", AT-199.

3rd judgement flicker is longer than others.

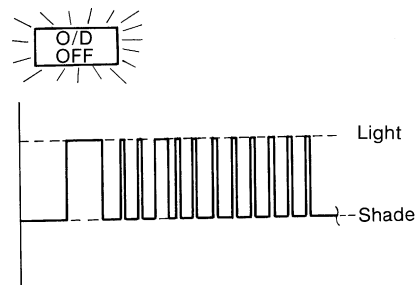

LAT428

Throttle position sensor circuit is short-circuited or disconnected.

⇒ Go to "DTC P1705 THROTTLE POSITION SENSOR", AT-179.

ON BOARD DIAGNOSTIC SYSTEM DESCRIPTION

Diagnostic Procedure Without CONSULT-II (Cont'd)

O/D OFF indicator lamp:

4th judgement flicker is longer than others.

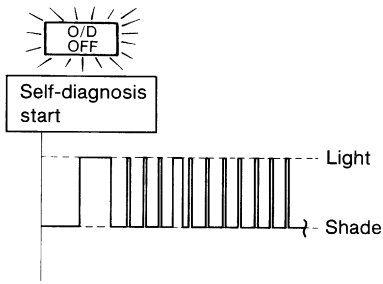

LAT429

Shift solenoid valve A circuit is short-circuited or disconnected.
⇒ Go to "DTC P0750 SHIFT SOLENOID VALVE A", AT-169.

5th judgement flicker is longer than others.

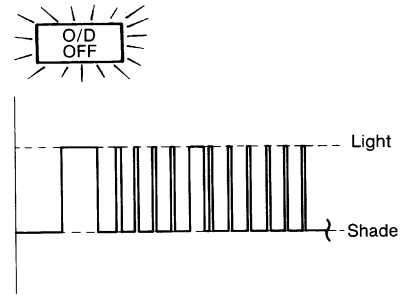

LAT430

Shift solenoid valve B circuit is short-circuited or disconnected.
⇒ Go to "DTC P0755 SHIFT SOLENOID VALVE B", AT-174.

6th judgement flicker is longer than others.

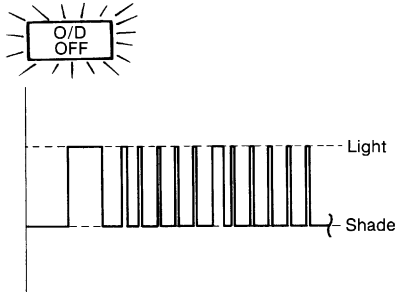

LAT431

Overrun clutch solenoid valve circuit is short-circuited or disconnected.
⇒ Go to "DTC P1760 OVERRUN CLUTCH SOLENOID VALVE", AT-188.

7th judgement flicker is longer than others.

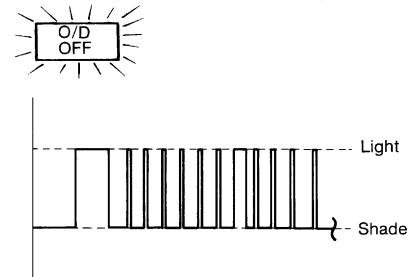

LAT432

Torque converter clutch solenoid valve circuit is short-circuited or disconnected.
⇒ Go to "DTC P0740 TORQUE CONVERTER CLUTCH SOLENOID VALVE", AT-152.

8th judgement flicker is longer than others.

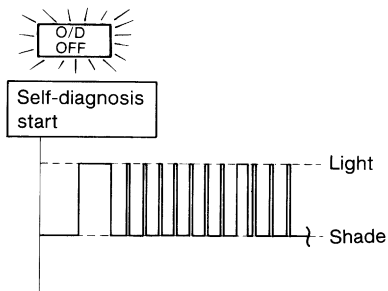

LAT433

A/T fluid temperature sensor is disconnected or TCM power source circuit is damaged.
⇒ Go to "DTC BATT/FLUID TEMP SEN (A/T FLUID TEMP SENSOR CIRCUIT AND TCM POWER SOURCE)", AT-193.

9th judgement flicker is longer than others.

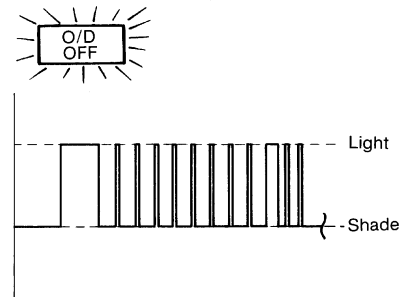

LAT434

Engine speed signal circuit is short-circuited or disconnected.
⇒ Go to "DTC P0725 ENGINE SPEED SIGNAL", AT-121.

GI

MA

EM

LC

EC

FE

CL

MT

AT

TF

PD

AX

SU

BR

ST

RS

BT

HA

SC

EL

IDX

ON BOARD DIAGNOSTIC SYSTEM DESCRIPTION

Diagnostic Procedure Without CONSULT-II (Cont'd)

O/D OFF indicator lamp:

10th judgement flicker is longer than others.

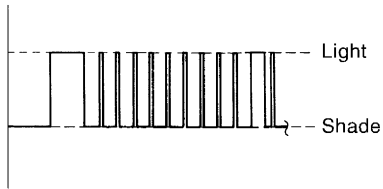
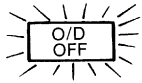

LAT435

⇒ Go to "DTC TURBINE REVOLUTION SENSOR", AT-164.

11th judgement flicker is longer than others.

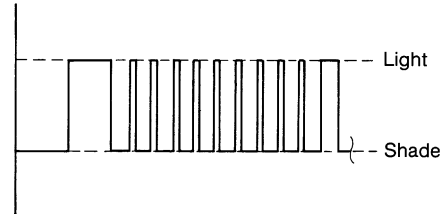
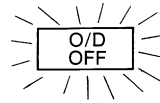

SAT455F

Line pressure solenoid valve circuit is short-circuited or disconnected.
⇒ Go to "DTC P0745 LINE PRESSURE SOLENOID VALVE", AT-164.

Flickers as shown below.

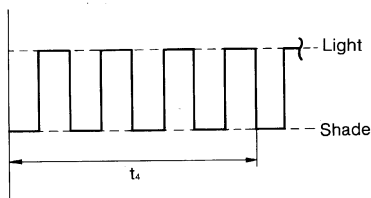
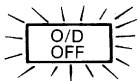

SAT457F

Battery power is low.
Battery has been disconnected for a long time.
Battery is connected conversely.
(When reconnecting TCM connectors. — This is not a problem.)

Lamp comes on.

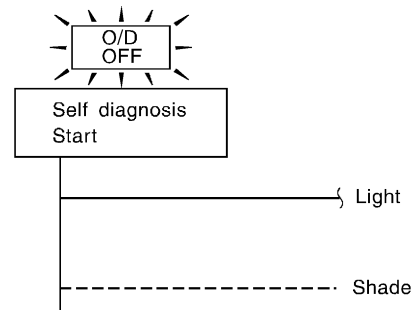

SAT367J

PNP switch, overdrive control switch or throttle position switch circuit is disconnected or TCM is damaged.
⇒ Go to "21. TCM Self-diagnosis Does Not Activate (PNP, Overdrive Control and Throttle Position Switches Circuit Checks), AT-252.

$t_1 = 2.5$ seconds $t_2 = 2.0$ seconds $t_3 = 1.0$ second $t_4 = 1.0$ second

TROUBLE DIAGNOSIS — INTRODUCTION

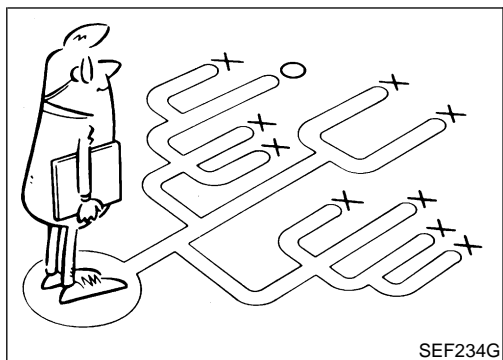
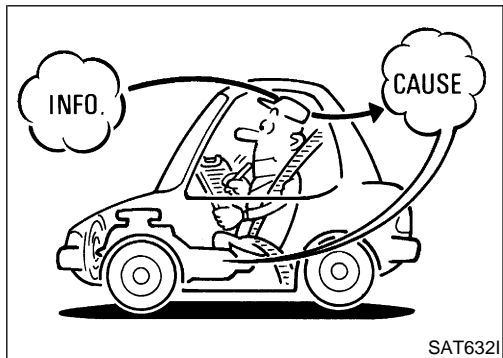
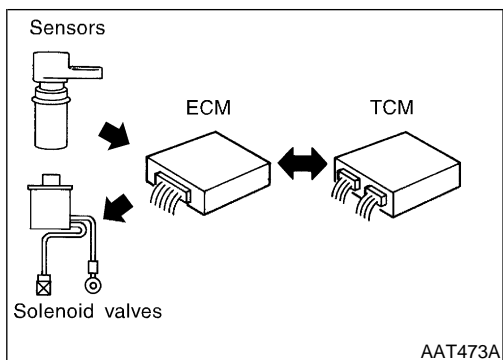

Introduction

NGAT0019

The TCM receives a signal from the vehicle speed sensor, throttle position sensor or PNP switch and provides shift control or lock-up control via A/T solenoid valves.

The TCM also communicates with the ECM by means of a signal sent from sensing elements used with the OBD-related parts of the A/T system for malfunction-diagnostic purposes. The TCM is capable of diagnosing malfunctioning parts while the ECM can store malfunctions in its memory.

Input and output signals must always be correct and stable in the operation of the A/T system. The A/T system must be in good operating condition and be free of valve seizure, solenoid valve malfunction, etc.

It is much more difficult to diagnose a problem that occurs intermittently rather than continuously. Most intermittent problems are caused by poor electric connections or improper wiring. In this case, careful checking of suspected circuits may help prevent the replacement of good parts.

A visual check only may not find the cause of the problems. A road test with CONSULT-II (or GST) or a circuit tester connected should be performed. Follow the "Work Flow". Refer to "Work Flow", AT-59.

Before undertaking actual checks, take a few minutes to talk with a customer who approaches with a driveability complaint. The customer can supply good information about such problems, especially intermittent ones. Find out what symptoms are present and under what conditions they occur. A "Diagnostic Worksheet" like the example should be used. Refer to "Diagnostic Worksheet", AT-57. Start your diagnosis by looking for "conventional" problems first. This will help troubleshoot driveability problems on an electronically controlled engine vehicle.

Also check related Service bulletins.

GI

MA

EM

LC

EC

FE

CL

MT

AT

TF

PD

AX

SU

BR

ST

RS

BT

HA

SC

EL

IDX

TROUBLE DIAGNOSIS — INTRODUCTION

Introduction (Cont'd)

Diagnostic Worksheet

-NGAT0019S0102

1.	<input type="checkbox"/> Read the Fail-safe Remarks and listen to customer complaints.	AT-8	GI		
2.	<input type="checkbox"/> CHECK A/T FLUID	AT-62			
	<input type="checkbox"/> Leakage (Follow specified procedure) <input type="checkbox"/> Fluid condition <input type="checkbox"/> Fluid level		MA		
3.	Perform STALL TEST and LINE PRESSURE TEST.	AT-62, AT-65	EM		
	<input type="checkbox"/> Stall test — Mark possible damaged components/others.		LC		
	<table border="1" style="width: 100%; border-collapse: collapse;"> <tr> <td style="width: 50%; vertical-align: top;"> <input type="checkbox"/> Torque converter one-way clutch <input type="checkbox"/> Reverse clutch <input type="checkbox"/> Forward clutch <input type="checkbox"/> Overrun clutch <input type="checkbox"/> Forward one-way clutch </td> <td style="width: 50%; vertical-align: top;"> <input type="checkbox"/> Low & reverse brake <input type="checkbox"/> Low one-way clutch <input type="checkbox"/> Engine <input type="checkbox"/> Line pressure is low <input type="checkbox"/> Clutches and brakes except high clutch and brake band are OK </td> </tr> </table>	<input type="checkbox"/> Torque converter one-way clutch <input type="checkbox"/> Reverse clutch <input type="checkbox"/> Forward clutch <input type="checkbox"/> Overrun clutch <input type="checkbox"/> Forward one-way clutch	<input type="checkbox"/> Low & reverse brake <input type="checkbox"/> Low one-way clutch <input type="checkbox"/> Engine <input type="checkbox"/> Line pressure is low <input type="checkbox"/> Clutches and brakes except high clutch and brake band are OK		EC
<input type="checkbox"/> Torque converter one-way clutch <input type="checkbox"/> Reverse clutch <input type="checkbox"/> Forward clutch <input type="checkbox"/> Overrun clutch <input type="checkbox"/> Forward one-way clutch	<input type="checkbox"/> Low & reverse brake <input type="checkbox"/> Low one-way clutch <input type="checkbox"/> Engine <input type="checkbox"/> Line pressure is low <input type="checkbox"/> Clutches and brakes except high clutch and brake band are OK				
	<input type="checkbox"/> Line pressure test — Suspected parts:		FE		
4.	<input type="checkbox"/> Perform all ROAD TEST and mark required procedures.	AT-66	CL		
4-1.	Check before engine is started.	AT-67			
	<input type="checkbox"/> SELF-DIAGNOSTIC PROCEDURE - Mark detected items.		MT		
	<input type="checkbox"/> PNP switch, AT-104. <input type="checkbox"/> A/T fluid temperature sensor, AT-110. <input type="checkbox"/> Vehicle speed sensor-A/T (Revolution sensor), AT-116. <input type="checkbox"/> Engine speed signal, AT-121. <input type="checkbox"/> Torque converter clutch solenoid valve, AT-152. <input type="checkbox"/> Line pressure solenoid valve, AT-164. <input type="checkbox"/> Shift solenoid valve A, AT-169. <input type="checkbox"/> Shift solenoid valve B, AT-174. <input type="checkbox"/> Throttle position sensor, AT-179. <input type="checkbox"/> Overrun clutch solenoid valve, AT-188. <input type="checkbox"/> A/T fluid temperature sensor and TCM power source, AT-193. <input type="checkbox"/> PNP, overdrive control and throttle position switches, AT-252. <input type="checkbox"/> Vehicle speed sensor-MTR, AT-199. <input type="checkbox"/> Control unit (RAM), control unit (ROM), AT-208. <input type="checkbox"/> Control unit (EEP ROM), AT-210. <input type="checkbox"/> Battery <input type="checkbox"/> Others		AT		
4-2.	Check at idle	AT-69	TF		
	<input type="checkbox"/> 1. O/D OFF Indicator Lamp Does Not Come On, AT-215. <input type="checkbox"/> 2. Engine Cannot Be Started In P And N Position, AT-217. <input type="checkbox"/> 3. In P Position, Vehicle Moves Forward Or Backward When Pushed, AT-218. <input type="checkbox"/> 4. In N Position, Vehicle Moves, AT-219. <input type="checkbox"/> 5. Large Shock. N → R Position, AT-221. <input type="checkbox"/> 6. Vehicle Does Not Creep Backward In R Position, AT-223. <input type="checkbox"/> 7. Vehicle Does Not Creep Forward In D, 2 Or 1 Position, AT-226.		PD		

AT

TF

PD

AX

SU

BR

ST

RS

BT

HA

SC

EL

IDX

TROUBLE DIAGNOSIS — INTRODUCTION

Introduction (Cont'd)

4.	4-3.	Cruise test	AT-70 AT-74
		Part-1	
		<input type="checkbox"/> 8. Vehicle Cannot Be Started From D ₁ , AT-229. <input type="checkbox"/> 9. A/T Does Not Shift: D ₁ → D ₂ Or Does Not Kickdown: D ₄ → D ₂ , AT-232. <input type="checkbox"/> 10. A/T Does Not Shift: D ₂ →D ₃ , AT-235. <input type="checkbox"/> 11. A/T Does Not Shift: D ₃ →D ₄ , AT-238. <input type="checkbox"/> 12. A/T Does Not Perform Lock-up, AT-241. <input type="checkbox"/> 13. A/T Does Not Hold Lock-up Condition, AT-243. <input type="checkbox"/> 14. Lock-up Is Not Released, AT-245. <input type="checkbox"/> 15. Engine Speed Does Not Return To Idle (Light Braking D ₄ → D ₃), AT-246.	
		Part-2	AT-78
		<input type="checkbox"/> 9. A/T Does Not Shift: D ₁ → D ₂ Or Does Not Kickdown: D ₄ → D ₂ , AT-232. <input type="checkbox"/> 10. A/T Does Not Shift: D ₂ →D ₃ , AT-235. <input type="checkbox"/> 11. A/T Does Not Shift: D ₃ →D ₄ , AT-238. <input type="checkbox"/> 16. Vehicle Does Not Start From D ₁ , AT-248.	
		Part-3	AT-80
		<input type="checkbox"/> 17. A/T Does Not Shift: D ₄ →D ₃ When Overdrive Control Switch ON → OFF, AT-249 <input type="checkbox"/> 15. Engine Speed Does Not Return To Idle (Engine Brake In D ₃), AT-246. <input type="checkbox"/> 18. A/T Does Not Shift: D ₃ →2 ₂ , When Selector Lever D → 2 Position, AT-250. <input type="checkbox"/> 15. Engine Speed Does Not Return To Idle (Engine Brake In 2 ₂), AT-246. <input type="checkbox"/> 19. A/T Does Not Shift: 2 ₂ →1 ₁ , When Selector Lever 2 → 1 Position, AT-251. <input type="checkbox"/> 20. Vehicle Does Not Decelerate By Engine Brake, AT-252. <input type="checkbox"/> SELF-DIAGNOSTIC PROCEDURE — Mark detected items.	
		<input type="checkbox"/> PNP switch, AT-104. <input type="checkbox"/> A/T fluid temperature sensor, AT-110. <input type="checkbox"/> Vehicle speed sensor-A/T (Revolution sensor), AT-116. <input type="checkbox"/> Engine speed signal, AT-121. <input type="checkbox"/> Torque converter clutch solenoid valve, AT-152. <input type="checkbox"/> Line pressure solenoid valve, AT-164. <input type="checkbox"/> Shift solenoid valve A, AT-169. <input type="checkbox"/> Shift solenoid valve B, AT-174. <input type="checkbox"/> Throttle position sensor, AT-179. <input type="checkbox"/> Overrun clutch solenoid valve, AT-188. <input type="checkbox"/> A/T fluid temperature sensor and TCM power source, AT-193. <input type="checkbox"/> PNP, overdrive control and throttle position switches, AT-252. <input type="checkbox"/> Vehicle speed sensor-MTR, AT-199. <input type="checkbox"/> Turbine revolution sensor (VG33ER only), AT-203. <input type="checkbox"/> Control unit (RAM), control unit (ROM), AT-208. <input type="checkbox"/> Control unit (EEP ROM), AT-210. <input type="checkbox"/> Battery <input type="checkbox"/> Others	
5.		<input type="checkbox"/> For self-diagnosis NG items, inspect each component. Repair or replace the damaged parts.	AT-38
6.		<input type="checkbox"/> Perform all ROAD TEST and re-mark required procedures.	AT-66
7.		<input type="checkbox"/> Perform DTC CONFIRMATION PROCEDURE for following MIL indicating items and check out NG items. Refer to EC-661 (VG33E only) or EC-1233 (VG33ER only), "Emission-related Diagnostic Information".	EC-661 (VG33E only) or EC-1233 (VG33ER only)
		<input type="checkbox"/> DTC (P0731, 1103) A/T 1st gear function, AT-125. <input type="checkbox"/> DTC (P0732, 1104) A/T 2nd gear function, AT-131. <input type="checkbox"/> DTC (P0733, 1105) A/T 3rd gear function, AT-137. <input type="checkbox"/> DTC (P0734, 1106) A/T 4th gear function, AT-143. <input type="checkbox"/> DTC (P0744, 1107) A/T TCC S/V function (lock-up), AT-157.	
8.		<input type="checkbox"/> Perform the Diagnostic Procedures for all remaining items marked NG. Repair or replace the damaged parts. Refer to the Symptom Chart when you perform the procedures. (The chart also shows some other possible symptoms and the component inspection orders.)	AT-84
9.		<input type="checkbox"/> Erase DTC from TCM and ECM memories.	AT-35

Work Flow

HOW TO PERFORM TROUBLE DIAGNOSES FOR QUICK AND ACCURATE REPAIR

NGAT0020

NGAT0020S01

A good understanding of the malfunction conditions can make troubleshooting faster and more accurate.

In general, each customer feels differently about a problem. It is important to fully understand the symptoms or conditions for a customer complaint.

Make good use of the two sheets provided. Refer to "INFORMATION FROM CUSTOMER", AT-56 and "DIAGNOSTIC WORKSHEET, AT-57 to perform the best troubleshooting possible.

GI

MA

EM

LC

EC

FE

CL

MT

AT

TF

PD

AX

SU

BR

ST

RS

BT

HA

SC

EL

IDX

TROUBLE DIAGNOSIS — INTRODUCTION

Work Flow (Cont'd)

WORK FLOW CHART

NGAT0020S02

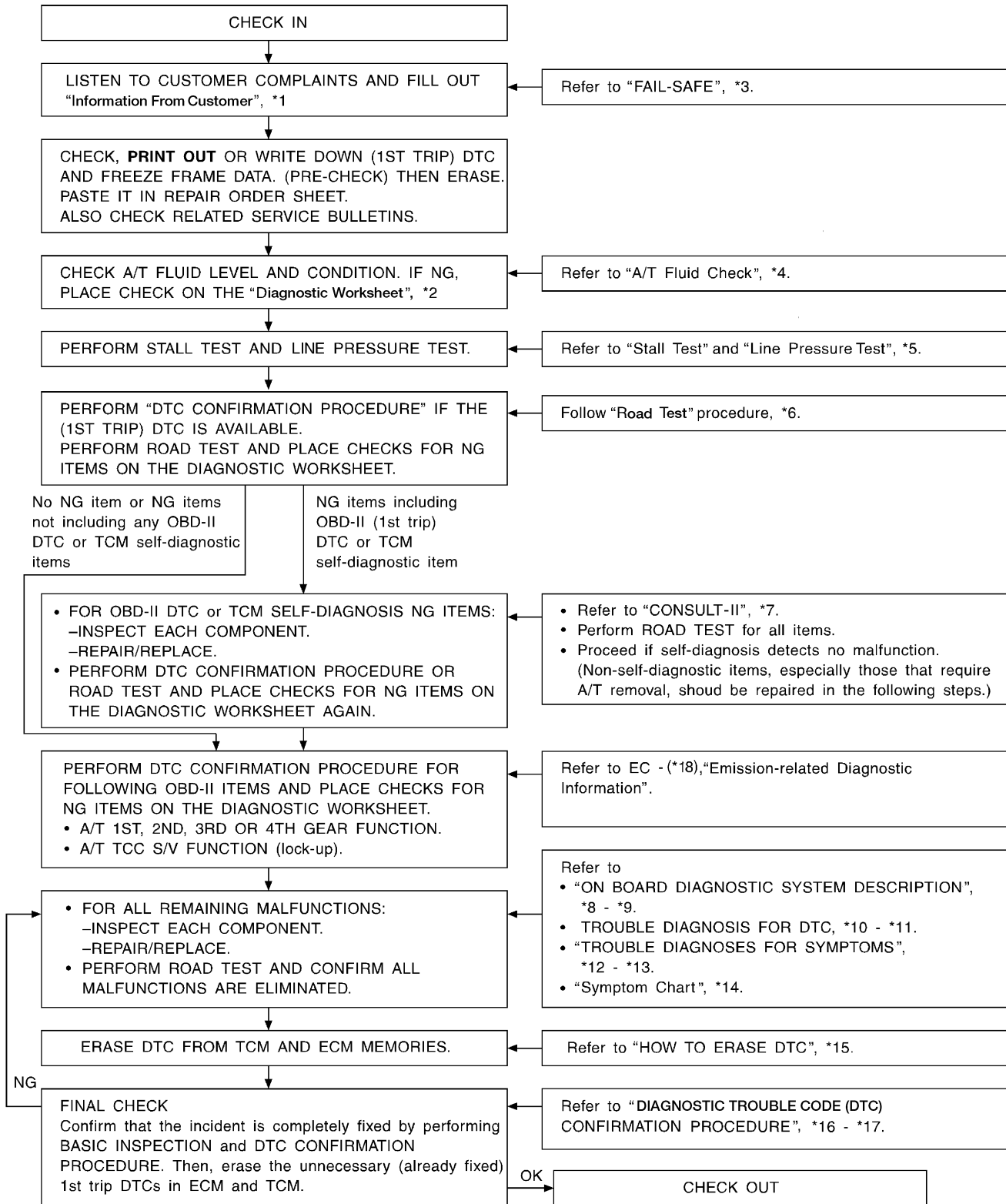

WAT372

*1: AT-56

*2: AT-57

*3: AT-8

*4: AT-62

*5: AT-62, 65

*6: AT-66

*7: AT-37

*8: AT-33

*9: AT-50

*10: AT-104

*11: AT-210

*12: AT-212

*13: AT-252

*14: AT-84

*15: AT-35

*16: AT-105

*17: AT-210

*18: **EC-661** (VG33E), **EC-1233**

TROUBLE DIAGNOSIS — INTRODUCTION

Work Flow (Cont'd)

(VG33ER)

GI

MA

EM

LC

EC

FE

CL

MT

AT

TF

PD

AX

SU

BR

ST

RS

BT

HA

SC

EL

IDX

TROUBLE DIAGNOSIS — BASIC INSPECTION

A/T Fluid Check

A/T Fluid Check

NGAT0021

FLUID LEAKAGE CHECK

NGAT0021S01

1. Clean area suspected of leaking. — for example, mating surface of converter housing and transmission case.
2. Start engine, apply foot brake, place selector lever in D position and wait a few minutes.
3. Stop engine.
4. Check for fresh leakage.

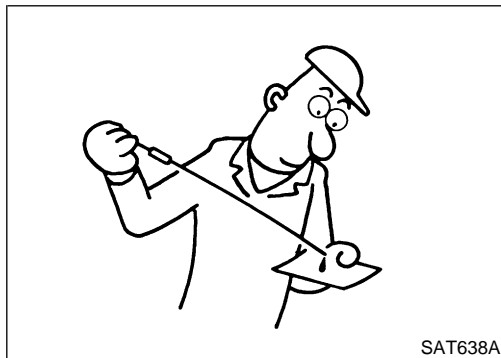

FLUID CONDITION CHECK

NGAT0021S02

Fluid color	Suspected problem
Dark or black with burned odor	Wear of frictional material
Milky pink	Water contamination — Road water entering through filler tube or breather
Varnished fluid, light to dark brown and tacky	Oxidation — Over or under filling, — Overheating

FLUID LEVEL CHECK

NGAT0021S03

Refer to **MA-39**, "Checking A/T Fluid".

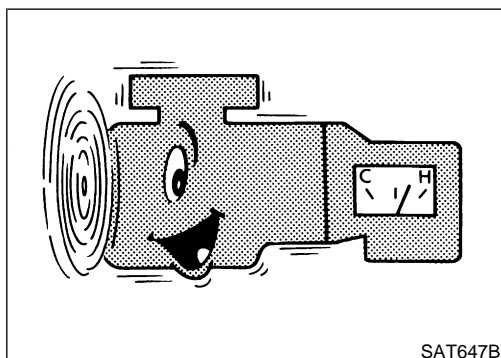

Stall Test

NGAT0022

STALL TEST PROCEDURE

NGAT0022S01

1. Check A/T fluid and engine oil levels. If necessary, add fluid and oil.
2. Drive vehicle for approx. 10 minutes or until engine oil and ATF reach operating temperature.

ATF operating temperature:

50 - 80°C (122 - 176°F)

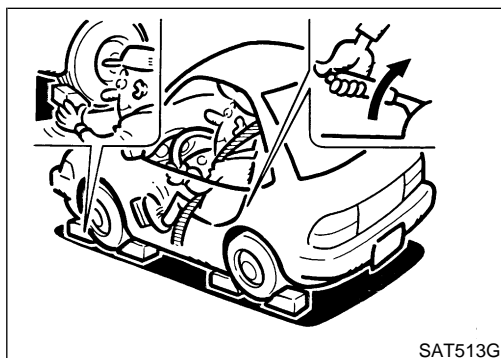

3. Set parking brake and block wheels.
 4. Install a tachometer where it can be seen by driver during test.
- **It is good practice to put a mark on point of specified engine rpm on indicator.**

TROUBLE DIAGNOSIS — BASIC INSPECTION

Stall Test (Cont'd)

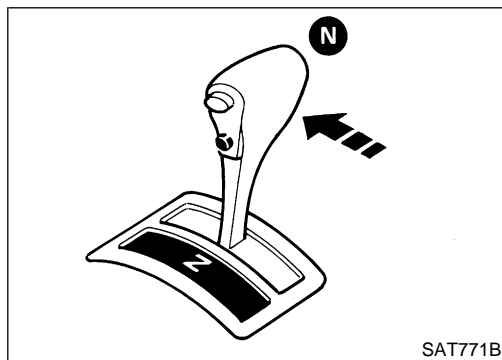
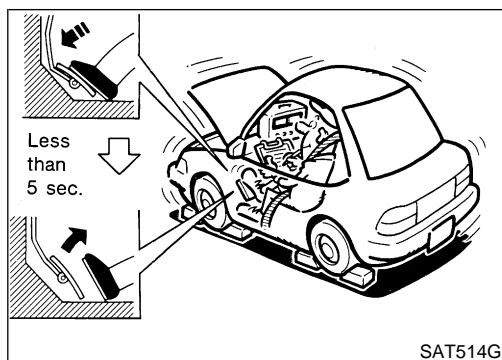

5. Start engine, apply foot brake, and place selector lever in D position.
6. Accelerate to wide open throttle gradually while applying foot brake.
7. Quickly note the engine stall revolution and immediately release throttle.

- **During test, never hold throttle wide open for more than 5 seconds.**

Stall revolution:
2,440 - 2,640 rpm

8. Move selector lever to N position.
9. Cool off ATF.
- **Run engine at idle for at least one minute.**
10. Repeat steps 5 through 9 with selector lever in 2, 1 and R positions.

JUDGEMENT OF STALL TEST

The test result and possible damaged components relating to each result are shown in the illustration. In order to pinpoint the possible damaged components, follow the "Work Flow" shown in AT-59.

NOTE:

Stall revolution is too high in D or 2 position:

- Slippage occurs in 1st gear but not in 2nd and 3rd gears. Low one-way clutch slippage
- Slippage occurs at the following gears:
1st through 3rd gears in D position and engine brake functions.
1st and 2nd gears in 2 position and engine brake functions with accelerator pedal released (fully closed throttle). Forward clutch or forward one-way clutch slippage

Stall revolution is too high in R position:

- Engine brake does not function in 1 position. Low & reverse brake slippage
- Engine brake functions in 1 position. Reverse clutch slippage

Stall revolution within specifications:

- Vehicle does not achieve speed of more than 80 km/h (50 MPH). One-way clutch seizure in torque converter housing

CAUTION:

Be careful since automatic fluid temperature increases abnormally.

- Slippage occurs in 3rd and 4th gears in D position. High clutch slippage
- Slippage occurs in 2nd and 4th gear in D position. Brake band slippage

Stall revolution less than specifications:

- Poor acceleration during starts. One-way clutch seizure in torque converter

GI
MA
EM
LC
EC
FE
CL
MT
AT
TF
PD
AX
SU
BR
ST
RS
BT
HA
SC
EL
IDX

TROUBLE DIAGNOSIS — BASIC INSPECTION

Stall Test (Cont'd)

Selector lever position	Judgement		
	L	O	H
D	L	O	H
2	L	O	H
1	L	O	O
R	L	H	H

O : Stall revolution is normal.
 H : Stall revolution is higher than specified.
 L : Stall revolution is lower than specified.

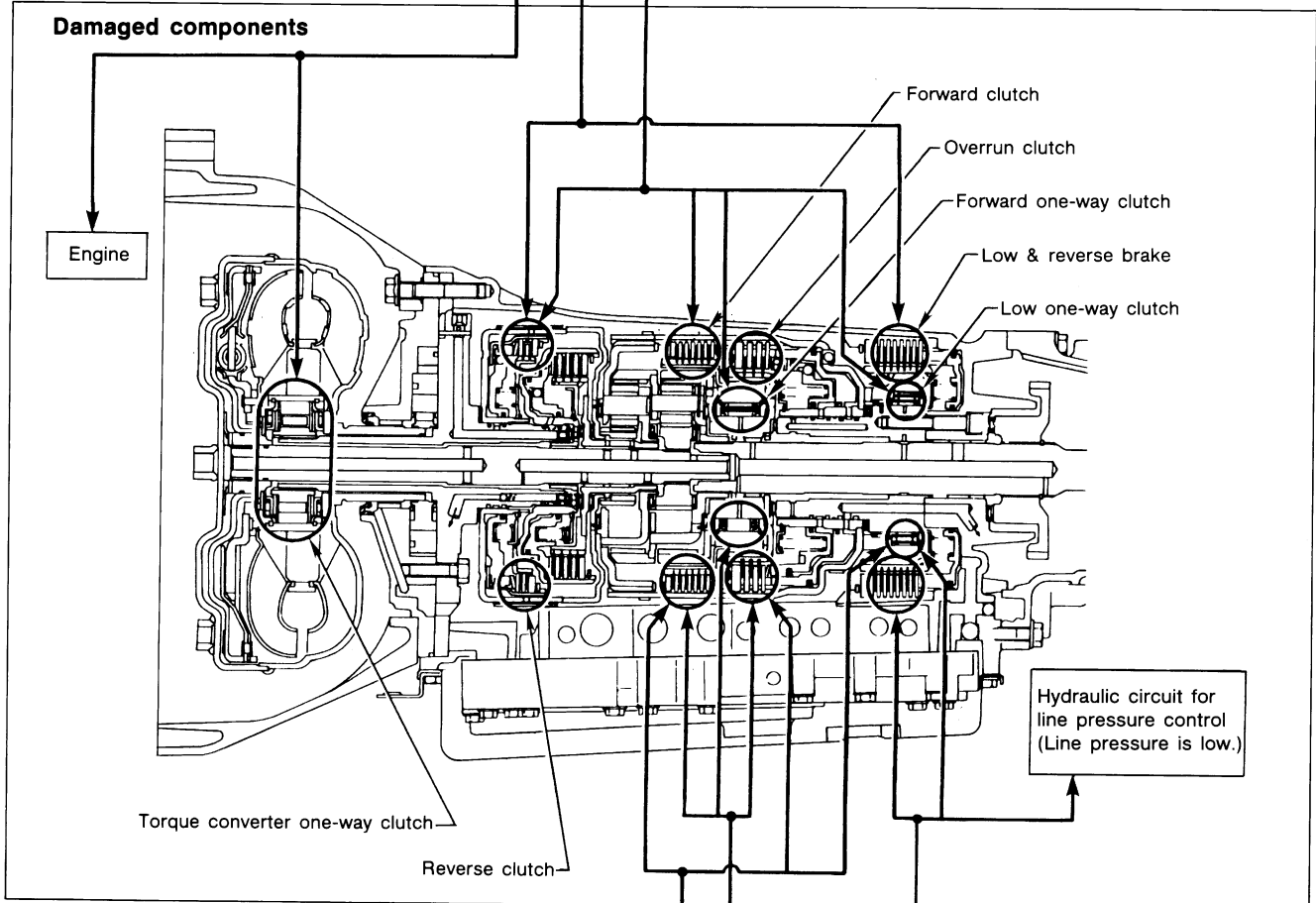

D	H	H	H	O
2	H	H	H	O
1	O	H	H	O
R	O	O	H	O
Selector lever position	Judgement			

SAT392H

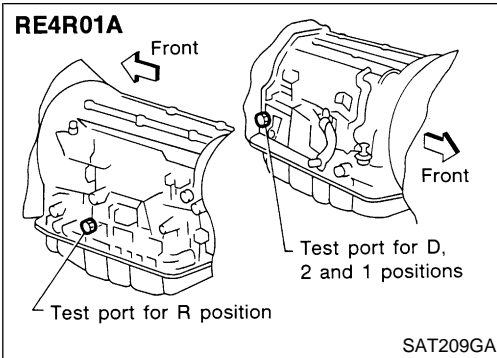

Line Pressure Test

LINE PRESSURE TEST PORTS

- Location of line pressure test ports.
- **Always replace line pressure plugs as they are self-sealing bolts.**

NGAT0023

NGAT0023S03

GI

MA

EM

LC

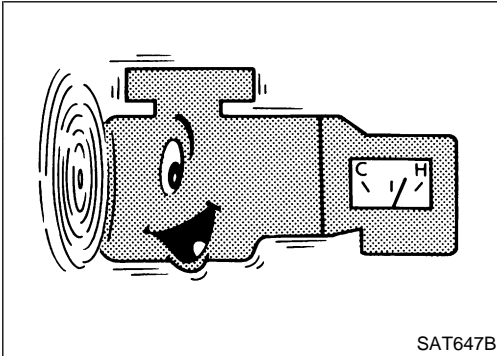

LINE PRESSURE TEST PROCEDURE

1. Check A/T fluid and engine oil levels. If necessary, add fluid and oil.
2. Drive vehicle for approx. 10 minutes or until engine oil and ATF reach operating temperature.

ATF operating temperature:
50 - 80°C (122 - 176°F)

NGAT0023S01

EC

FE

CL

MT

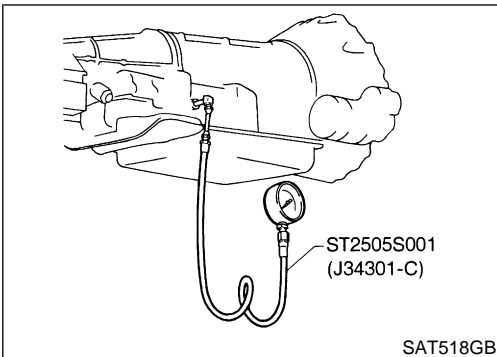

3. Install pressure gauge to corresponding line pressure port.

AT

TF

PD

AX

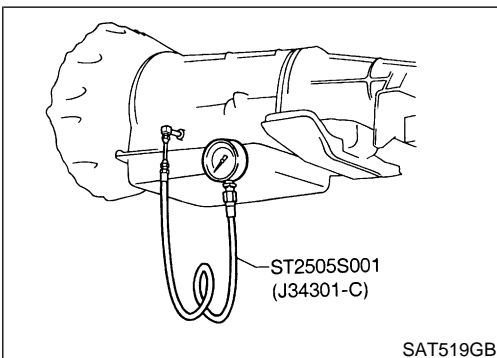

SU

BR

ST

RS

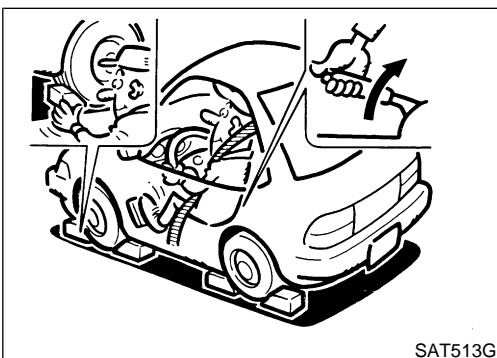

4. Set parking brake and block wheels.
 - **Continue to depress brake pedal fully while line pressure test is being performed at stall speed.**

BT

HA

SC

EL

IDX

TROUBLE DIAGNOSIS — BASIC INSPECTION

Line Pressure Test (Cont'd)

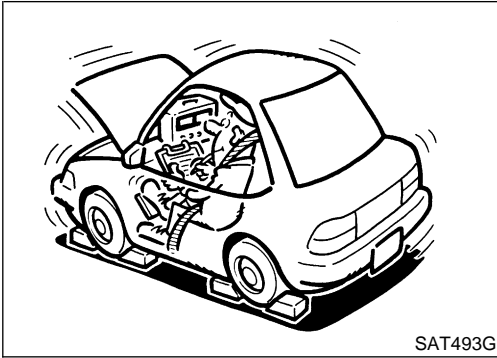

5. Start engine and measure line pressure at idle and stall speed.
 - **When measuring line pressure at stall speed, follow the stall test procedure.**
- Line pressure:**
Refer to “Line Pressure”, AT-349.

JUDGEMENT OF LINE PRESSURE TEST

NGAT0023S02

	Judgement	Suspected parts
At idle	Line pressure is low in all positions.	<ul style="list-style-type: none"> ● Oil pump wear ● Control piston damage ● Pressure regulator valve or plug sticking ● Spring for pressure regulator valve damaged ● Fluid pressure leakage between oil strainer and pressure regulator valve ● Clogged strainer
	Line pressure is low in particular position.	<ul style="list-style-type: none"> ● Fluid pressure leakage between manual valve and particular clutch ● For example, line pressure is: <ul style="list-style-type: none"> — Low in R and 1 positions, but — Normal in D and 2 positions. Then, fluid leakage exists at or around low and reverse brake circuit. Refer to “CLUTCH AND BAND CHART”, AT-17.
	Line pressure is high.	<ul style="list-style-type: none"> ● Maladjustment of throttle position sensor ● Fluid temperature sensor damaged ● Line pressure solenoid valve sticking ● Short circuit of line pressure solenoid valve circuit ● Pressure modifier valve sticking ● Pressure regulator valve or plug sticking ● Open in dropping resistor circuit
At stall speed	Line pressure is low.	<ul style="list-style-type: none"> ● Maladjustment of throttle position sensor ● Line pressure solenoid valve sticking ● Short circuit of line pressure solenoid valve circuit ● Pressure regulator valve or plug sticking ● Pressure modifier valve sticking ● Pilot valve sticking

ROAD TEST PROCEDURE

1. Check before engine is started.



2. Check at idle.



3. Cruise test.

SAT786A

Road Test

DESCRIPTION

NGAT0024

NGAT0024S01

- The purpose of this test is to determine overall performance of the A/T and analyze causes of problems.
- The road test consists of the following three parts:
 - a) Check before engine is started
 - b) Check at idle
 - c) Cruise test

TROUBLE DIAGNOSIS — BASIC INSPECTION

Road Test (Cont'd)

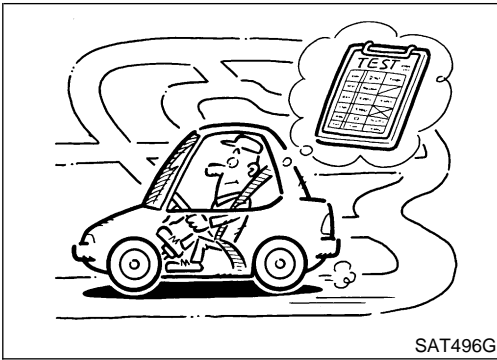

- Before road test, familiarize yourself with all test procedures and items to check.
- Conduct tests on all items until specified symptom is found. Troubleshoot items which check out No Good after road test. Refer to "ON BOARD DIAGNOSTIC SYSTEM DESCRIPTION" and "TROUBLE DIAGNOSES FOR SYMPTOMS", AT-33 to AT-50 and AT-212 to AT-252.

GI
MA

EM

LC

1. CHECK BEFORE ENGINE IS STARTED

NGAT0024S02

1	CHECK O/D OFF INDICATOR LAMP		
		<p>1. Park vehicle on flat surface. 2. Move selector lever to P position. 3. Turn ignition switch to OFF position. Wait at least 5 seconds.</p> <div style="text-align: center;"> <p>OVERDRIVE ON/OFF →</p> </div> <p>4. Turn ignition switch to ON position. (Do not start engine.) 5. Does O/D OFF indicator lamp come on for about 2 seconds?</p> <div style="text-align: center;"> <p>O/D OFF indicator lamp</p> </div>	<p>EC</p> <p>FE</p> <p>CL</p> <p>MT</p> <p style="background-color: black; color: white; text-align: center; font-weight: bold;">AT</p> <p>TF</p> <p>PD</p> <p>AX</p> <p>SU</p> <p>BR</p> <p>ST</p> <p>WAT496</p>
Yes or No			
Yes	▶	GO TO 2.	
No	▶	Go to "1. O/D OFF Indicator Lamp Does Not Come On", AT-215.	

EC

FE

CL

MT

AT

TF

SAT967I

PD

AX

SU

BR

ST

WAT496

RS

BT

HA

SC

EL

IDX

TROUBLE DIAGNOSIS — BASIC INSPECTION

Road Test (Cont'd)

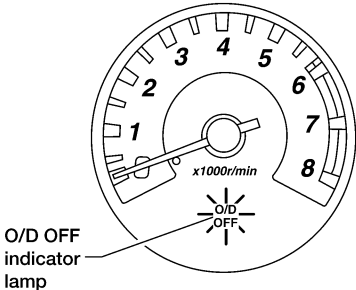
2	CHECK O/D OFF INDICATOR LAMP	
Does O/D OFF indicator lamp flicker for about 8 seconds?		
		
WAT496		
Yes or No		
Yes	▶	Perform self-diagnosis. Refer to "TCM SELF-DIAGNOSIS PROCEDURE (NO TOOLS)", AT-47.
No	▶	GO TO 3.

3	CHECK NG ITEM	
1. Turn ignition switch to OFF position. 2. Perform self-diagnosis and note NG items. Refer to "TCM SELF-DIAGNOSIS PROCEDURE (NO TOOLS)", AT-47.		
	▶	Go to "2. CHECK AT IDLE", AT-69.

TROUBLE DIAGNOSIS — BASIC INSPECTION

Road Test (Cont'd)

2. CHECK AT IDLE

-NGAT0024S03

1	CHECK ENGINE START	
<ol style="list-style-type: none"> 1. Park vehicle on flat surface. 2. Turn ignition switch to OFF position. 3. Move selector lever to P or N position. 4. Turn ignition switch to start position. 5. Is engine started? 		
Yes or No		
Yes	▶	GO TO 2.
No	▶	Go to "2. Engine Cannot Be Started In P and N Position", AT-217.

GI
MA
EM
LC

2	CHECK ENGINE START	
<ol style="list-style-type: none"> 1. Turn ignition switch to OFF position. 2. Move selector lever to D, 1, 2 or R position. 3. Turn ignition switch to start position. 4. Is engine started? 		
Yes or No		
Yes	▶	Go to "2. Engine Cannot Be Started In P and N Position", AT-217.
No	▶	GO TO 3.

EC
FE
CL
MT

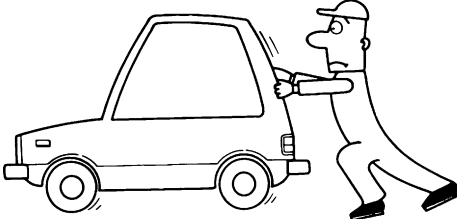
3	CHECK VEHICLE MOVE	
<ol style="list-style-type: none"> 1. Turn ignition switch to OFF position. 2. Move selector lever to P position. 3. Release parking brake. 4. Push vehicle forward or backward. 5. Does vehicle move when it is pushed forward or backward? 		
		
SAT796A		
Yes or No		
Yes	▶	Go to "3. In P Position, Vehicle Moves Forward Or Backward When Pushed", AT-218.
No	▶	GO TO 4.

AT
TF
PD
AX
SU
BR
ST
RS

4	CHECK VEHICLE MOVE	
<ol style="list-style-type: none"> 1. Apply parking brake. 2. Move selector lever to N position. 3. Turn ignition switch to START position and start engine. 4. Release parking brake. 5. Does vehicle move forward or backward? 		
Yes or No		
Yes	▶	Go to "4. In N Position, Vehicle Moves", AT-219.
No	▶	GO TO 5.

BT
HA
SC
EL

TROUBLE DIAGNOSIS — BASIC INSPECTION

Road Test (Cont'd)

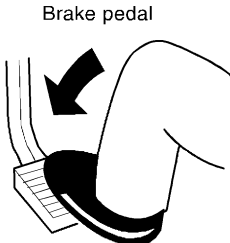
5	CHECK SHIFT SHOCK	
<ol style="list-style-type: none"> 1. Apply foot brake. 2. Move selector lever to R position. 3. Is there large shock when changing from N to R position? 		
		
SAT082J		
Yes or No		
Yes	▶	Go to "5. Large Shock. N → R Position", AT-221.
No	▶	GO TO 6.

6	CHECK VEHICLE MOVE	
<ol style="list-style-type: none"> 1. Release foot brake for several seconds. 2. Does vehicle creep backward when foot brake is released? 		
Yes or No		
Yes	▶	GO TO 7.
No	▶	Go to "6. Vehicle Does Not Creep Backward In R Position", AT-223.

7	CHECK VEHICLE MOVE	
<ol style="list-style-type: none"> 1. Move selector lever to D, 2 and 1 position and check if vehicle creeps forward. 2. Does vehicle creep forward in all three positions? 		
Yes or No		
Yes	▶	Go to "3. Cruise test", AT-70.
No	▶	Go to "7. Vehicle Does Not Creep Forward In D, 2 Or 1 Position", AT-226.

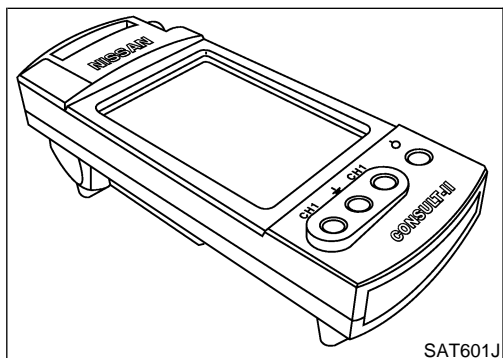

SAT601J

3. CRUISE TEST

- Check all items listed in Parts 1 through 3.

NGAT0024S04

With CONSULT-II

- Using CONSULT-II, conduct a cruise test and record the result.
- Print the result and ensure that shifts and lock-ups take place as per "Shift Schedule".

NGAT0024S0401

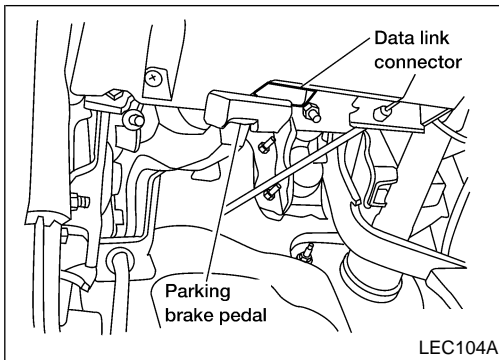

CONSULT-II Setting Procedure

NGAT0024S0402

1. Turn ignition switch OFF.
2. Connect "CONSULT-II" to Data Link Connector.
Data link connector is located in the lower instrument panel on driver side.

GI
MA

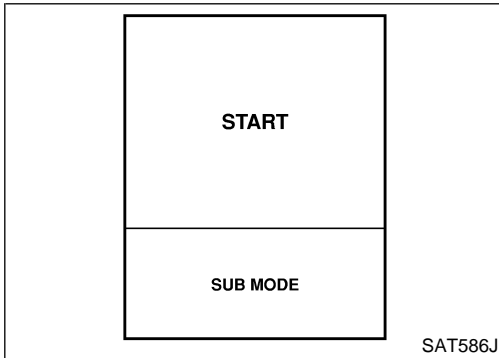

3. Turn ignition switch ON.
4. Touch "START".

EC
FE
CL

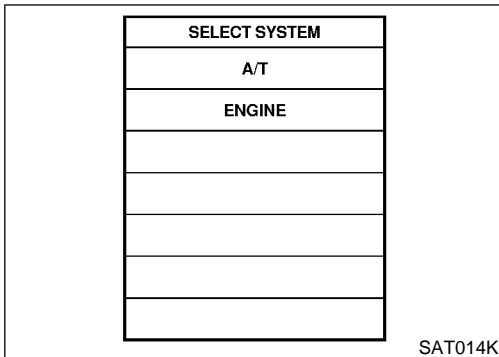

5. Touch "A/T".

AT
TF
PD
AX

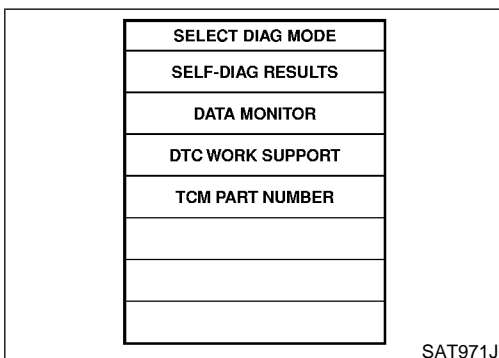

6. Touch "DATA MONITOR".

SU
BR
ST
RS

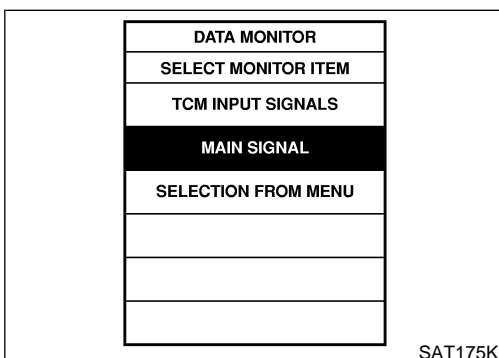

7. Touch "MAIN SIGNALS" or "TCM INPUT SIGNALS".
8. See "Numerical Display", "Barchart Display" or "Line Graph Display".

BT
HA
SC
EL

TROUBLE DIAGNOSIS — BASIC INSPECTION

Road Test (Cont'd)

SET RECORDING CONDITION						
AUTO TRIG						
MANU TRIG						
TRIGGER POINT						
<<	<input type="text"/>	>>				
0%	20%	40%	60%	80%	100%	
Recording Speed						
MIN	MAX					
<<	<input type="text"/>	>>				
/64	/32	/16	/8	/4	/2	FULL

SAT973J

9. Touch "SETTING" to set recording condition ("AUTO TRIG" or "MANU TRIG") and touch "BACK".
10. Touch "START".

DATA MONITOR	
MONITOR	NO DTC
ENGINE SPEED	XXX rpm
GEAR	XXX
SLCT LVR POSI	N/P
VEHICLE SPEED	XXX km/h
THROTTLE POSI	XXX
LINE PRES DTY	XX%
TCC S/V DUTY	XX%
SHIFT S/V A	XX
SHIFT S/V B	XX

SAT134K

11. When performing cruise test, touch "RECORD".

DATA MONITOR		
Recording Data	X%	DTC
		DETECTED
ENGINE SPEED	XXX rpm	
GEAR	XXX	
SLCT LVR POSI	N/P	
VEHICLE SPEED	XXX km/h	
THROTTLE POSI	XXX	
LINE PRES DTY	XX%	
TCC S/V DUTY	XX%	
SHIFT S/V A	XX	
SHIFT S/V B	XX	

SAT135K

12. After finishing cruise test part 1, touch "STOP".

REAL-TIME DIAG	
ENG SPEED SIG	

SAT987J

13. Touch "STORE" and touch "BACK".

STORE	
SYSTEM	SAVE REC DATA

SAT974J

TROUBLE DIAGNOSIS — BASIC INSPECTION

Road Test (Cont'd)

Cruise Test — Part 1

=NGAT0024S0404

1 CHECK STARTING GEAR (D₁) POSITION

1. Drive vehicle for approx. 10 minutes to warm engine oil and ATF up to operating temperature.

ATF operating temperature:

50 - 80°C (122 - 176°F)

2. Park vehicle on flat surface.
3. Set overdrive control switch to ON position.
4. Move selector lever to P position.

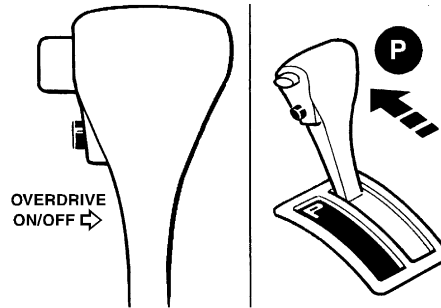

SAT001J

5. Start engine.
6. Move selector lever to D position.

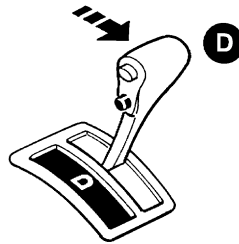

SAT952I

7. Accelerate vehicle by constantly depressing accelerator pedal halfway.

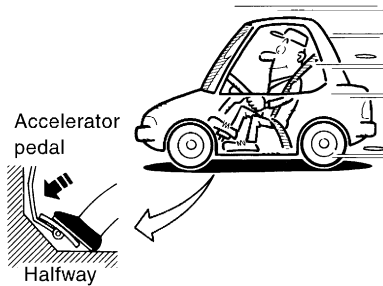

SAT953I

8. Does vehicle start from D₁?

Read gear position.

Yes or No

Yes



GO TO 2.

No



Go to "8. Vehicle Cannot Be Started From D₁", AT-229.

TROUBLE DIAGNOSIS — BASIC INSPECTION

Road Test (Cont'd)

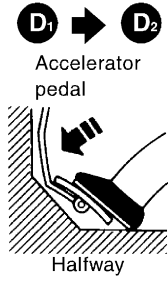
2	CHECK SHIFT UP (D₁ TO D₂)	
Does A/T shift from D ₁ to D ₂ at the specified speed? <input type="checkbox"/> Read gear position, throttle opening and vehicle speed. Specified speed when shifting from D ₁ to D ₂ : Refer to Shift schedule, AT-348.		
		
Yes or No		
Yes	▶	GO TO 3.
No	▶	Go to "9. A/T Does Not Shift: D ₁ → D ₂ or Does Not Kickdown: D ₄ → D ₂ ", AT-232.

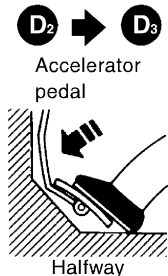
3	CHECK SHIFT UP (D₂ TO D₃)	
Does A/T shift from D ₂ to D ₃ at the specified speed? <input type="checkbox"/> Read gear position, throttle opening and vehicle speed. Specified speed when shifting from D ₂ to D ₃ : Refer to Shift schedule, AT-348.		
		
Yes or No		
Yes	▶	GO TO 4.
No	▶	Go to "10. A/T Does Not Shift: D ₂ → D ₃ ", AT-235.

GI
 MA
 EM
 LC
 EC
 FE
 CL
 MT
 AT
 TF
 PD
 AX
 SU
 BR
 ST
 RS
 BT
 HA
 SC
 EL
 IDX

TROUBLE DIAGNOSIS — BASIC INSPECTION

Road Test (Cont'd)

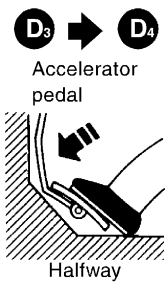
4	CHECK SHIFT UP (D₃ TO D₄)	
Does A/T shift from D ₃ to D ₄ at the specified speed? <input type="checkbox"/> Read gear position, throttle opening and vehicle speed. Specified speed when shifting from D ₃ to D ₄ : Refer to Shift schedule, AT-348.		
		
Yes or No		
Yes	▶	GO TO 5.
No	▶	Go to "11. A/T Does Not Shift: D ₃ → D ₄ ", AT-238.

SAT956I

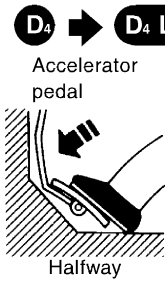
5	CHECK LOCK-UP (D₄ TO D₄ L/U)	
Does A/T perform lock-up at the specified speed? <input type="checkbox"/> Read vehicle speed, throttle position when lock-up duty becomes 94%. Specified speed when lock-up occurs: Refer to Shift schedule, AT-348.		
		
Yes or No		
Yes	▶	GO TO 6.
No	▶	Go to "12. A/T Does Not Perform Lock-up", AT-241.

SAT957I

6	CHECK HOLD LOCK-UP	
Does A/T hold lock-up condition for more than 30 seconds? <p style="text-align: center;">Yes or No</p>		
Yes	▶	GO TO 7.
No	▶	Go to "13. A/T Does Not Hold Lock-up Condition", AT-243.

TROUBLE DIAGNOSIS — BASIC INSPECTION

Road Test (Cont'd)

7	CHECK LOCK-UP OFF (D₄ L/U TO D₄)	
<p>1. Release accelerator pedal. 2. Is lock-up released when accelerator pedal is released?</p> <div style="text-align: center;"> </div> <p style="text-align: right;">SAT958I</p>		
Yes or No		
Yes	▶	GO TO 8.
No	▶	Go to "14. Lock-up Is Not Released", AT-245.

8	CHECK SHIFT DOWN (D₄ TO D₃)	
<p>1. Decelerate vehicle by applying foot brake lightly. 2. Does engine speed return to idle smoothly when A/T is shifted from D₄ to D₃?</p> <p> Read gear position and engine speed.</p> <div style="text-align: center;"> </div> <p style="text-align: right;">SAT959I</p>		
Yes or No		
Yes	▶	1. Stop vehicle. 2. Go to "Cruise test — Part 2", AT-78.
No	▶	Go to "15. Engine Speed Does Not Return To Idle (Light Braking D ₄ → D ₃)", AT-246.

GI
MA
EM
LC
EC
FE
CL
MT
AT
TF
PD
AX
SU
BR
ST
RS
BT
HA
SC
EL
IDX

TROUBLE DIAGNOSIS — BASIC INSPECTION

Road Test (Cont'd)

Cruise Test — Part 2

=NGAT0024S0405

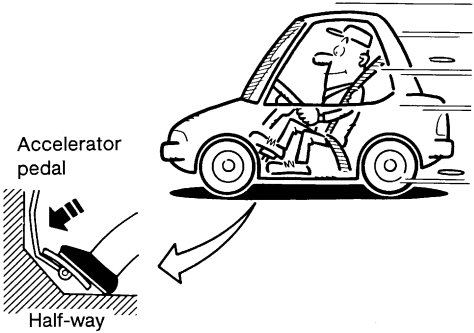
1	CHECK STARTING GEAR (D₁) POSITION	
<p>1. Confirm overdrive control switch is in ON position. 2. Confirm selector lever is in D position. 3. Accelerate vehicle by half throttle again. 4. Does vehicle start from D₁?</p> <p><input type="checkbox"/> Read gear position.</p>		
 <p>Accelerator pedal Half-way</p>		
Yes or No		
Yes	▶	GO TO 2.
No	▶	Go to "16. Vehicle Does Not Start From D ₁ ", AT-248.

SAT495G

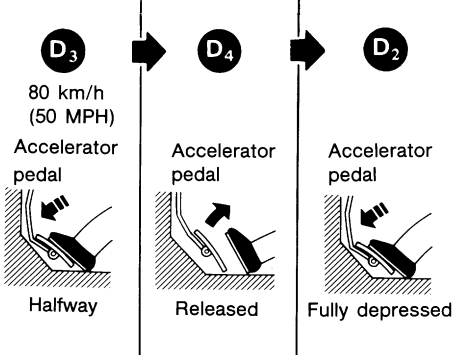
2	CHECK SHIFT UP AND SHIFT DOWN (D₃ TO D₄ TO D₂)	
<p>1. Accelerate vehicle to 80 km/h (50 MPH) as shown in illustration. 2. Release accelerator pedal and then quickly depress it fully. 3. Does A/T shift from D₄ to D₂ as soon as accelerator pedal is depressed fully?</p> <p><input type="checkbox"/> Read gear position and throttle position.</p>		
 <p>D₃ D₄ D₂</p> <p>80 km/h (50 MPH) Accelerator pedal Halfway</p> <p>Accelerator pedal Released</p> <p>Accelerator pedal Fully depressed</p>		
Yes or No		
Yes	▶	GO TO 3.
No	▶	Go to "9. A/T Does Not Shift: D ₃ → D ₄ Or Does Not Kickdown: D ₄ → D ₂ ", AT-232.

SAT404H

TROUBLE DIAGNOSIS — BASIC INSPECTION

Road Test (Cont'd)

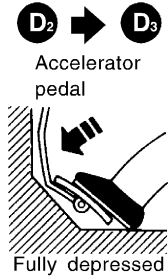
3	CHECK SHIFT UP (D₂ TO D₃)	<p>Does A/T shift from D₂ to D₃ at the specified speed?</p> <p>Ⓜ Read gear position, throttle position and vehicle speed. Specified speed when shifting from D₂ to D₃: Refer to Shift schedule, AT-348.</p> <div style="text-align: center;">  <p>Accelerator pedal Fully depressed</p> </div> <p style="text-align: right;">SAT960I</p>
Yes or No		
Yes	▶	GO TO 4.
No	▶	Go to "10. A/T Does Not Shift: D ₂ → D ₃ ", AT-235.

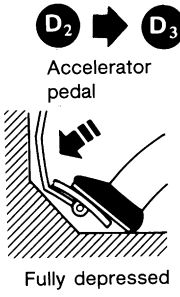
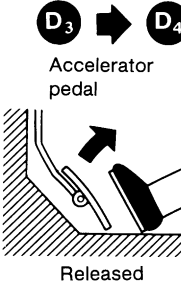
4	CHECK SHIFT UP (D₃ TO D₄) AND ENGINE BRAKE	<p>Release accelerator pedal after shifting from D₂ to D₃.</p> <p>Does A/T shift from D₃ to D₄ and does vehicle decelerate by engine brake?</p> <p>Ⓜ Read gear position, throttle position and vehicle speed.</p> <div style="display: flex; justify-content: space-around; align-items: center;"> <div style="text-align: center;">  <p>Accelerator pedal Fully depressed</p> </div> <div style="text-align: center;">  <p>Accelerator pedal Released</p> </div> </div> <p style="text-align: right;">SAT405H</p>
Yes or No		
Yes	▶	<ol style="list-style-type: none"> 1. Stop vehicle. 2. Go to "Cruise test — Part 3", AT-80.
No	▶	Go to "11. A/T Does Not Shift: D ₃ → D ₄ ", AT-238.

GI
 MA
 EM
 LC
 EC
 FE
 CL
 MT
AT
 TF
 PD
 AX
 SU
 BR
 ST
 RS
 BT
 HA
 SC
 EL
 IDX

TROUBLE DIAGNOSIS — BASIC INSPECTION

Road Test (Cont'd)

Cruise Test — Part 3

=NGAT0024S0406

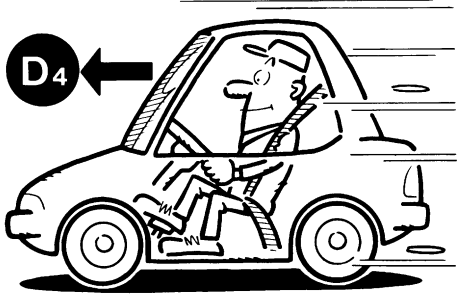
1	VEHICLE SPEED D₄ POSITION
<ol style="list-style-type: none"> 1. Confirm overdrive control switch is in ON position. 2. Confirm selector lever is in D position. 3. Accelerate vehicle using half-throttle to D₄. 	
	
SAT812A	
▶ GO TO 2.	

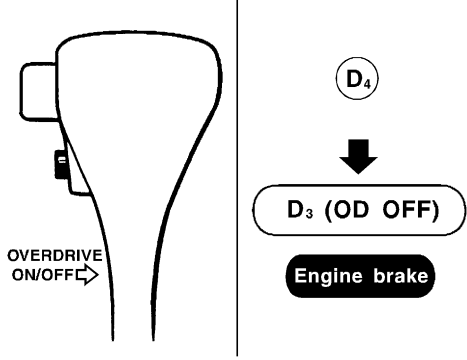
2	CHECK SHIFT DOWN (D₄ TO D₃)
<ol style="list-style-type: none"> 1. Release accelerator pedal. 2. Set overdrive control switch to OFF position while driving in D₄. 3. Does A/T shift from D₄ to D₃ (O/D OFF)? <p><input checked="" type="checkbox"/> Read gear position and vehicle speed.</p>	
	
Yes or No	
Yes	▶ GO TO 3.
No	▶ Go to "17. A/T Does Not Shift: D ₄ → D ₃ , When Overdrive Control Switch ON → OFF, AT-249.

SAT999I

TROUBLE DIAGNOSIS — BASIC INSPECTION

Road Test (Cont'd)

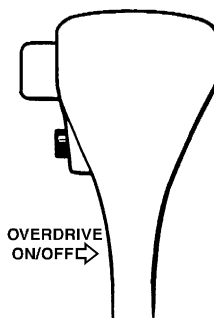
3	CHECK ENGINE BRAKE	<p>Does vehicle decelerate by engine brake?</p> <div style="display: flex; justify-content: space-around; align-items: center;">  <div style="text-align: center;"> <p>D₄</p> <p>↓</p> <p>D₃ (OD OFF)</p> <p>Engine brake</p> </div> </div> <p style="text-align: right;">SAT999I</p>	
Yes or No		Yes	▶ GO TO 4.
		No	▶ Go to "15. Engine Speed Does Not Return To Idle (Light Braking D ₄ → D ₃)", AT-246.

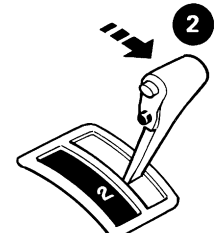
4	CHECK SHIFT DOWN (D₃ TO D₂)	<p>1. Move selector lever from D to 2 position while driving in D₃ (O/D OFF). 2. Does A/T shift from D₃ (O/D OFF) to 2₂? ☑ Read gear position.</p> <div style="display: flex; justify-content: space-around; align-items: center;">  <div style="text-align: center;"> <p>D₃ (OD OFF)</p> <p>↓</p> <p>2₂</p> <p>Engine brake</p> </div> </div> <p style="text-align: right;">SAT791GA</p>	
Yes or No		Yes	▶ GO TO 5.
		No	▶ Go to "18. A/T Does Not Shift: D ₃ → D ₂ , When Selector Lever "D" → "2" Position", AT-250.

GI
MA
EM
LC
EC
FE
CL
MT
AT
TF
PD
AX
SU
BR
ST
RS
BT
HA
SC
EL
IDX

TROUBLE DIAGNOSIS — BASIC INSPECTION

Road Test (Cont'd)

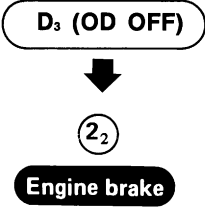
5	CHECK ENGINE BRAKE		
Does vehicle decelerate by engine brake?			
			SAT791GA
Yes or No			
Yes	▶	GO TO 6.	
No	▶	Go to "15. Engine Speed Does Not Return To Idle (Light Braking D ₄ → D ₃)", AT-246.	

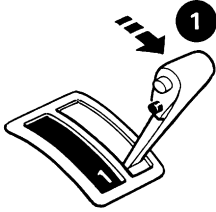
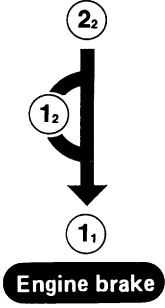
6	CHECK SHIFT DOWN (2₂ TO 1₁)		
1. Move selector lever from 2 to 1 position while driving in 2 ₂ . 2. Does A/T shift from 2 ₂ to 1 ₁ position?			
			SAT778B
Yes or No			
Yes	▶	GO TO 7.	
No	▶	Go to "19. A/T Does Not Shift: 2 ₂ → 1 ₁ , When Selector lever 2 → 1 Position", AT-251.	

TROUBLE DIAGNOSIS — BASIC INSPECTION

Road Test (Cont'd)

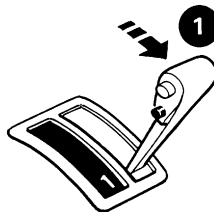
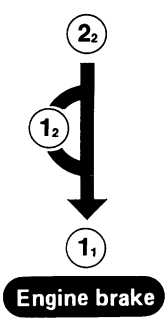
7	CHECK ENGINE BRAKE	
<p>Does vehicle decelerate by engine brake?</p> <div style="display: flex; justify-content: space-around; align-items: center;">   </div> <p style="text-align: center;">Yes or No</p> <p style="text-align: right;">SAT778B</p>		
Yes	▶	<ol style="list-style-type: none"> 1. Stop vehicle. 2. Perform self-diagnosis. Refer to TCM Self-Diagnosis Procedure (No Tools), AT-47.
No	▶	Go to "20. Vehicle Does Not Decelerate By Engine Brake", AT-252.

GI
MA
EM
LC
EC
FE
CL
MT
AT
TF
PD
AX
SU
BR
ST
RS
BT
HA
SC
EL
IDX

TROUBLE DIAGNOSIS — GENERAL DESCRIPTION

Symptom Chart

Symptom Chart

NGAT0026

Numbers are arranged in order of inspection.

Perform inspections starting with number one and work up.

Items	Symptom	Condition	Diagnostic Item	Reference Page	
				VG33E only	VG33ER only
No Lock-up Engagement/ TCC Inoperative	Torque converter is not locked up.	ON vehicle	1. Throttle position sensor (Adjustment)	EC-701	EC-1273
			2. Vehicle speed sensor-A/T (Revolution sensor) and vehicle speed sensor-MTR	AT-116, 199	
			3. Park/neutral position (PNP) switch adjustment	AT-270	
			4. Engine speed signal	AT-121	
			5. A/T fluid temperature sensor	AT-110	
			6. Line pressure test	AT-65	
			7. Torque converter clutch solenoid valve	AT-152	
			8. Control valve assembly	AT-267	
		OFF vehicle	9. Torque converter	AT-278	
	Torque converter clutch piston slip.	ON vehicle	1. Fluid level	AT-62	
			2. Throttle position sensor (Adjustment)	EC-701	EC-1273
			3. Line pressure test	AT-65	
			4. Torque converter clutch solenoid valve	AT-152	
			5. Line pressure solenoid valve	AT-164	
			6. Control valve assembly	AT-267	
			OFF vehicle	7. Torque converter	AT-278
	Lock-up point is extremely high or low. AT-241	ON vehicle	1. Throttle position sensor (Adjustment)	EC-701	EC-1273
			2. Vehicle speed sensor-A/T (Revolution sensor) and vehicle speed sensor-MTR	AT-116, 199	
			3. Torque converter clutch solenoid valve	AT-152	
			4. Control valve assembly	AT-267	
Shift Shock	Sharp shock in shifting from N to D position.	ON vehicle	1. Engine idling rpm	EC-648	EC-1220
			2. Throttle position sensor (Adjustment)	EC-701	EC-1273
			3. Line pressure test	AT-65	
			4. A/T fluid temperature sensor	AT-110	
			5. Engine speed signal	AT-121	
			6. Line pressure solenoid valve	AT-164	
			7. Control valve assembly	AT-267	
			8. Accumulator N-D	AT-267	
		OFF vehicle	9. Turbine revolution sensor	—	AT-203
			10. Forward clutch	AT-312	

TROUBLE DIAGNOSIS — GENERAL DESCRIPTION

Symptom Chart (Cont'd)

Items	Symptom	Condition	Diagnostic Item	Reference Page		
				VG33E only	VG33ER only	
Shift Shock	Too sharp a shock in change from D ₁ to D ₂ .	ON vehicle	1. Throttle position sensor (Adjustment)	EC-701	EC-1273	GI
			2. Line pressure test	AT-65		MA
			3. Accumulator servo release	AT-267		EM
			4. Control valve assembly	AT-267		EM
			5. A/T fluid temperature sensor	AT-110		LC
		OFF vehicle	6. Brake band	AT-341		LC
	Too sharp a shock in change from D ₂ to D ₃ .	ON vehicle	1. Throttle position sensor (Adjustment)	EC-701	EC-1273	EC
			2. Line pressure test	AT-65		EC
			3. Control valve assembly	AT-267		FE
		OFF vehicle	4. High clutch	AT-310		FE
			5. Brake band	AT-341		CL
	Too sharp a shock in change from D ₃ to D ₄ .	ON vehicle	1. Throttle position sensor (Adjustment)	EC-701	EC-1273	CL
			2. Line pressure test	AT-65		MT
			3. Control valve assembly	AT-267		MT
		OFF vehicle	4. Brake band	AT-341		AT
			5. Overrun clutch	AT-312		AT
	Gear change shock felt during deceleration by releasing accelerator pedal.	ON vehicle	1. Throttle position sensor (Adjustment)	EC-701	EC-1273	TF
			2. Line pressure test	AT-65		TF
			3. Overrun clutch solenoid valve	AT-188		PD
			4. Control valve assembly	AT-267		AX
Large shock changing from 1 ₂ to 1 ₁ in 1 position.	ON vehicle	1. Control valve assembly	AT-267		SU	
	ON vehicle	2. Low & reverse brake	AT-316		SU	

GI
MA
EM
LC
EC
FE
CL
MT
AT
TF
PD
AX
SU
BR
ST
RS
BT
HA
SC
EL
IDX

TROUBLE DIAGNOSIS — GENERAL DESCRIPTION

Symptom Chart (Cont'd)

Items	Symptom	Condition	Diagnostic Item	Reference Page	
				VG33E only	VG33ER only
Improper Shift Timing	Too high a gear change point from D ₁ to D ₂ , from D ₂ to D ₃ , from D ₃ to D ₄ . AT-232, 235, 238	ON vehicle	1. Throttle position sensor (Adjustment)	EC-701	EC-1273
			2. Vehicle speed sensor-A/T (Revolution sensor) and vehicle speed sensor-MTR	AT-116, 199	
			3. Shift solenoid valve A	AT-169	
			4. Shift solenoid valve B	AT-174	
	Gear change directly from D ₁ to D ₃ occurs.	ON vehicle	1. Fluid level	AT-62	
		OFF vehicle	2. Accumulator servo release	AT-267	
	Too high a change point from D ₄ to D ₃ , from D ₃ to D ₂ , from D ₂ to D ₁ .	ON vehicle	1. Throttle position sensor (Adjustment)	EC-701	EC-1273
			2. Vehicle speed sensor-A/T (Revolution sensor) and vehicle speed sensor-MTR	AT-116, 199	
			3. Shift solenoid valve A	AT-169	
			4. Shift solenoid valve B	AT-174	
Kickdown does not operate when depressing pedal in D ₄ within kick-down vehicle speed.	ON vehicle	1. Throttle position sensor (Adjustment)	EC-701	EC-1273	
		2. Vehicle speed sensor-A/T (Revolution sensor) and vehicle speed sensor-MTR	AT-116, 199		
		3. Shift solenoid valve A	AT-169		
		4. Shift solenoid valve B	AT-174		
Improper Shift Timing	Kickdown operates or engine over-runs when depressing pedal in D ₄ beyond kick-down vehicle speed limit.	ON vehicle	1. Vehicle speed sensor-A/T (Revolution sensor) and vehicle speed sensor-MTR	AT-116, 199	
			2. Throttle position sensor (Adjustment)	EC-701	EC-1273
			3. Shift solenoid valve A	AT-169	
			4. Shift solenoid valve B	AT-174	
	Gear change from 2 ₂ to 2 ₃ in 2 position.	ON vehicle	1. Park/neutral position (PNP) switch adjustment	AT-270	
	Gear change from 1 ₁ to 1 ₂ in 1 position.	ON vehicle	1. Park/neutral position (PNP) switch adjustment	AT-270	
2. Manual control linkage adjustment			AT-270		

TROUBLE DIAGNOSIS — GENERAL DESCRIPTION

Symptom Chart (Cont'd)

Items	Symptom	Condition	Diagnostic Item	Reference Page		
				VG33E only	VG33ER only	
No Down Shift	Failure to change gear from D ₄ to D ₃ .	ON vehicle	1. Fluid level	AT-62		GI
			2. Throttle position sensor (Adjustment)	EC-701	EC-1273	MA
			3. Overrun clutch solenoid valve	AT-188		EM
			4. Shift solenoid valve A	AT-169		LC
			5. Line pressure solenoid valve	AT-164		EC
			6. Control valve assembly	AT-267		FE
		OFF vehicle	7. Low & reverse brake	AT-316		CL
			8. Overrun clutch	AT-312		MT
	Failure to change gear from D ₃ to D ₂ or from D ₄ to D ₂ .	ON vehicle	1. Fluid level	AT-62		AT
			2. Throttle position sensor (Adjustment)	EC-701	EC-1273	TF
			3. Shift solenoid valve A	AT-169		PD
			4. Shift solenoid valve B	AT-174		AX
			5. Control valve assembly	AT-267		SU
		OFF vehicle	6. High clutch	AT-310		BR
			7. Brake band	AT-341		ST
	Failure to change gear from D ₂ to D ₁ or from D ₃ to D ₁ .	ON vehicle	1. Fluid level	AT-62		RS
			2. Throttle position sensor (Adjustment)	EC-701	EC-1273	BT
			3. Shift solenoid valve A	AT-169		HA
			4. Shift solenoid valve B	AT-174		SC
			5. Control valve assembly	AT-267		EL
		OFF vehicle	6. Low one-way clutch	AT-320		IDX
			7. High clutch	AT-310		
			8. Brake band	AT-341		

TROUBLE DIAGNOSIS — GENERAL DESCRIPTION

Symptom Chart (Cont'd)

Items	Symptom	Condition	Diagnostic Item	Reference Page	
				VG33E only	VG33ER only
No Down Shift	Failure to change from D ₃ to 2 ₂ when changing lever into 2 position. AT-246	ON vehicle	1. Park/neutral position (PNP) switch adjustment	AT-270	
			2. Throttle position sensor (Adjustment)	EC-701	EC-1273
			3. Overrun clutch solenoid valve	AT-188	
			4. Shift solenoid valve B	AT-174	
			5. Shift solenoid valve A	AT-169	
			6. Control valve assembly	AT-267	
			7. Manual control linkage adjustment	AT-270	
	OFF vehicle	8. Brake band	AT-341		
		9. Overrun clutch	AT-312		
	Does not change from 1 ₂ to 1 ₁ in 1 position.	ON vehicle	1. Park/neutral position (PNP) switch adjustment	AT-270	
			2. Vehicle speed sensor-A/T (Revolution sensor) and vehicle speed sensor-MTR	AT-116, 199	
			3. Shift solenoid valve A	AT-169	
			4. Control valve assembly	AT-267	
			5. Overrun clutch solenoid valve	AT-188	
OFF vehicle		6. Overrun clutch	AT-312		
		7. Low & reverse brake	AT-316		
No Up Shift	Failure to change gear from D ₁ to D ₂ .	ON vehicle	1. Park/neutral position (PNP) switch adjustment	AT-270	
			2. Manual control linkage adjustment	AT-270	
			3. Shift solenoid valve A	AT-169	
			4. Control valve assembly	AT-267	
			5. Vehicle speed sensor-A/T (Revolution sensor) and vehicle speed sensor-MTR	AT-116, 199	
		OFF vehicle	6. Brake band	AT-341	
	Failure to change gear from D ₂ to D ₃ .	ON vehicle	1. Park/neutral position (PNP) switch adjustment	AT-270	
			2. Manual control linkage adjustment	AT-270	
			3. Shift solenoid valve B	AT-174	
			4. Control valve assembly	AT-267	
			5. Vehicle speed sensor-A/T (Revolution sensor) and vehicle speed sensor-MTR	AT-116, 199	
		OFF vehicle	6. High clutch	AT-310	
			7. Brake band	AT-341	

TROUBLE DIAGNOSIS — GENERAL DESCRIPTION

Symptom Chart (Cont'd)

Items	Symptom	Condition	Diagnostic Item	Reference Page		
				VG33E only	VG33ER only	
No Up Shift	Failure to change gear from D ₃ to D ₄ .	ON vehicle	1. Park/neutral position (PNP) switch adjustment	AT-270		GI
			2. Manual control linkage adjustment	AT-270		MA
			3. Shift solenoid valve A	AT-169		EM
			4. Vehicle speed sensor-A/T (Revolution sensor) and vehicle speed sensor-MTR	AT-116, 199		LC
			5. A/T fluid temperature sensor	AT-110		EC
		OFF vehicle	6. Brake band	AT-341		EC
	A/T does not shift to D ₄ when driving with over-drive control switch ON.	ON vehicle	1. Throttle position sensor (Adjustment)	EC-701	EC-1273	
			2. Park/neutral position (PNP) switch adjustment	AT-270		FE
			3. Vehicle speed sensor-A/T (Revolution sensor) and vehicle speed sensor-MTR	AT-116, 199		CL
			4. Shift solenoid valve A	AT-169		MT
5. Overrun clutch solenoid valve			AT-188		AT	
6. Control valve assembly			AT-267			
7. A/T fluid temperature sensor			AT-110			
8. Line pressure solenoid valve			AT-164			
		OFF vehicle	9. Brake band	AT-341		TF
			10. Overrun clutch	AT-312		PD
Slips/Will Not Engage	Vehicle will not run in R position (but runs in D, 2 and 1 positions). Clutch slips. Very poor acceleration. AT-223	ON vehicle	1. Manual control linkage adjustment	AT-270		
			2. Line pressure test	AT-65		AX
			3. Line pressure solenoid valve	AT-164		SU
			4. Control valve assembly	AT-267		
		OFF vehicle	5. Reverse clutch	AT-306		BR
			6. High clutch	AT-310		
			7. Forward clutch	AT-312		ST
			8. Overrun clutch	AT-312		
			9. Low & reverse brake	AT-316		RS
		ON vehicle	1. Manual control linkage adjustment	AT-270		BT
	OFF vehicle	2. Low one-way clutch	AT-320		HA	

TROUBLE DIAGNOSIS — GENERAL DESCRIPTION

Symptom Chart (Cont'd)

Items	Symptom	Condition	Diagnostic Item	Reference Page	
				VG33E only	VG33ER only
Slips/Will Not Engage	Vehicle will not run in D, 1, 2 positions (but runs in R position). Clutch slips. Very poor acceleration. AT-226	ON vehicle	1. Fluid level	AT-62	
			2. Line pressure test	AT-65	
			3. Line pressure solenoid valve	AT-164	
			4. Control valve assembly	AT-267	
			5. Accumulator N-D	AT-267	
		OFF vehicle	6. Reverse clutch	AT-306	
			7. High clutch	AT-310	
			8. Forward clutch	AT-312	
			9. Forward one-way clutch	AT-322	
			10. Low one-way clutch	AT-320	
	Clutches or brakes slip somewhat in starting.	ON vehicle	1. Fluid level	AT-62	
			2. Manual control linkage adjustment	AT-270	
			3. Throttle position sensor (Adjustment)	EC-701	EC-1273
			4. Line pressure test	AT-65	
			5. Line pressure solenoid valve	AT-164	
			6. Control valve assembly	AT-267	
			7. Accumulator N-D	AT-267	
		OFF vehicle	8. Forward clutch	AT-312	
			9. Reverse clutch	AT-306	
			10. Low & reverse brake	AT-316	
			11. Oil pump	AT-289	
			12. Torque converter	AT-278	
	No creep at all. AT-223, 226	ON vehicle	1. Fluid level	AT-62	
			2. Line pressure test	AT-65	
3. Control valve assembly			AT-267		
OFF vehicle		4. Forward clutch	AT-312		
		5. Oil pump	AT-289		
		6. Torque converter	AT-278		
Almost no shock or clutches slipping in change from D ₁ to D ₂ .	ON vehicle	1. Fluid level	AT-62		
		2. Throttle position sensor (Adjustment)	EC-701	EC-1273	
		3. Line pressure test	AT-65		
		4. Accumulator servo release	AT-267		
		5. Control valve assembly	AT-267		
	OFF vehicle	6. Brake band	AT-341		

TROUBLE DIAGNOSIS — GENERAL DESCRIPTION

Symptom Chart (Cont'd)

Items	Symptom	Condition	Diagnostic Item	Reference Page		
				VG33E only	VG33ER only	
Slips/Will Not Engage	Almost no shock or slipping in change from D ₂ to D ₃ .	ON vehicle	1. Fluid level	AT-62		GI
			2. Throttle position sensor (Adjustment)	EC-701	EC-1273	MA
			3. Line pressure test	AT-65		EM
			4. Control valve assembly	AT-267		
		OFF vehicle	5. High clutch	AT-310		LC
			6. Forward clutch	AT-312		
	Almost no shock or slipping in change from D ₃ to D ₄ .	ON vehicle	1. Fluid level	AT-62		EC
			2. Throttle position sensor (Adjustment)	EC-701	EC-1273	FE
			3. Line pressure test	AT-65		
			4. Control valve assembly	AT-267		
		OFF vehicle	5. High clutch	AT-310		CL
			6. Brake band	AT-341		
	Races extremely fast or slips in changing from D ₄ to D ₃ when depressing pedal.	ON vehicle	1. Fluid level	AT-62		MT
			2. Throttle position sensor (Adjustment)	EC-701	EC-1273	AT
			3. Line pressure test	AT-65		TF
			4. Line pressure solenoid valve	AT-164		
			5. Control valve assembly	AT-267		PD
		OFF vehicle	6. High clutch	AT-310		
			7. Forward clutch	AT-312		
	Races extremely fast or slips in changing from D ₄ to D ₂ when depressing pedal.	ON vehicle	1. Fluid level	AT-62		AX
			2. Throttle position sensor (Adjustment)	EC-701	EC-1273	SU
			3. Line pressure test	AT-65		BR
			4. Line pressure solenoid valve	AT-164		
			5. Shift solenoid valve A	AT-169		ST
6. Control valve assembly			AT-267			
OFF vehicle		7. Brake band	AT-341		RS	
		8. Forward clutch	AT-312		BT	
Races extremely fast or slips in changing from D ₃ to D ₂ when depressing pedal.	ON vehicle	1. Fluid level	AT-62		HA	
		2. Throttle position sensor (Adjustment)	EC-701	EC-1273	SC	
		3. Line pressure test	AT-65		EL	
		4. Line pressure solenoid valve	AT-164			
		5. Control valve assembly	AT-267			
		6. A/T fluid temperature sensor	AT-110			
	OFF vehicle	7. Brake band	AT-341			
		8. Forward clutch	AT-312			
		9. High clutch	AT-310			

TROUBLE DIAGNOSIS — GENERAL DESCRIPTION

Symptom Chart (Cont'd)

Items	Symptom	Condition	Diagnostic Item	Reference Page	
				VG33E only	VG33ER only
Slips/Will Not Engage	Races extremely fast or slips in changing from D ₄ or D ₃ to D ₁ when depressing pedal.	ON vehicle	1. Fluid level	AT-62	
			2. Throttle position sensor (Adjustment)	EC-701	EC-1273
			3. Line pressure test	AT-65	
			4. Line pressure solenoid valve	AT-164	
			5. Control valve assembly	AT-267	
		OFF vehicle	6. Forward clutch	AT-312	
			7. Forward one-way clutch	AT-322	
			8. Low one-way clutch	AT-320	
	Vehicle will not run in any position.	ON vehicle	1. Fluid level	AT-62	
			2. Manual control linkage adjustment	AT-270	
3. Line pressure test			AT-65		
4. Line pressure solenoid valve			AT-164		
OFF vehicle		5. Oil pump	AT-289		
		6. High clutch	AT-310		
		7. Brake band	AT-341		
		8. Low & reverse brake	AT-316		
		9. Torque converter	AT-278		
		10. Parking pawl components	AT-329		

TROUBLE DIAGNOSIS — GENERAL DESCRIPTION

Symptom Chart (Cont'd)

Items	Symptom	Condition	Diagnostic Item	Reference Page		
				VG33E only	VG33ER only	
NOT USED	Engine cannot be started in P and N positions. AT-217	ON vehicle	1. Ignition switch and starter	EL-12 , and SC-12		GI
			2. Manual control linkage adjustment	AT-270		MA
			3. Park/neutral position (PNP) switch adjustment	AT-270		EM
	Engine starts in positions other than P and N. AT-217	ON vehicle	1. Manual control linkage adjustment	AT-270		LC
			2. Park/neutral position (PNP) switch adjustment	AT-270		EC
	Transmission noise in P and N positions.	ON vehicle	1. Fluid level	AT-62		FE
			2. Line pressure test	AT-65		FE
			3. Throttle position sensor (Adjustment)	EC-701	EC-1273	CL
			4. Vehicle speed sensor-A/T (Revolution sensor) and vehicle speed sensor-MTR	AT-116, 199		CL
			5. Engine speed signal	AT-121		MT
		OFF vehicle	6. Oil pump	AT-289		AT
			7. Torque converter	AT-278		AT
	Vehicle moves when changing into P position or parking gear does not disengage when shifted out of P position. AT-217	ON vehicle	1. Manual control linkage adjustment	AT-270		TF
		OFF vehicle	2. Parking pawl components	AT-329		PD

GI

MA

EM

LC

EC

FE

CL

MT

AT

TF

PD

AX

SU

BR

ST

RS

BT

HA

SC

EL

IDX

TROUBLE DIAGNOSIS — GENERAL DESCRIPTION

Symptom Chart (Cont'd)

Items	Symptom	Condition	Diagnostic Item	Reference Page		
				VG33E only	VG33ER only	
NOT USED	Vehicle runs in N position. AT-219	ON vehicle	1. Manual control linkage adjustment	AT-270		
		OFF vehicle	2. Forward clutch	AT-312		
			3. Reverse clutch	AT-306		
			4. Overrun clutch	AT-312		
	Vehicle braked when shifting into R position.	ON vehicle	1. Fluid level	AT-62		
			2. Manual control linkage adjustment	AT-270		
			3. Line pressure test	AT-65		
			4. Line pressure solenoid valve	AT-164		
			5. Control valve assembly	AT-267		
		OFF vehicle	6. High clutch	AT-310		
			7. Brake band	AT-325		
			8. Forward clutch	AT-312		
			9. Overrun clutch	AT-312		
	Excessive creep.	ON vehicle	1. Engine idling rpm	EC-648	EC-1220	
	Engine stops when shifting lever into R, D, 2 and 1.	ON vehicle	1. Engine idling rpm	EC-648	EC-1220	
			2. Torque converter clutch solenoid valve	AT-152		
		3. Control valve assembly	AT-267			
	Vehicle braked by gear change from D ₁ to D ₂ .	OFF vehicle	4. Torque converter	AT-278		
		ON vehicle	1. Fluid level	AT-62		
			OFF vehicle	2. Reverse clutch	AT-306	
				3. Low & reverse brake	AT-316	
				4. High clutch	AT-310	
	5. Low one-way clutch	AT-320				
	Vehicle braked by gear change from D ₂ to D ₃ .	ON vehicle	1. Fluid level	AT-62		
		OFF vehicle	2. Brake band	AT-325		
	Vehicle braked by gear change from D ₃ to D ₄ .	ON vehicle	1. Fluid level	AT-62		
		OFF vehicle	2. Overrun clutch	AT-312		
			3. Forward one-way clutch	AT-322		
4. Reverse clutch			AT-306			

TROUBLE DIAGNOSIS — GENERAL DESCRIPTION

Symptom Chart (Cont'd)

Items	Symptom	Condition	Diagnostic Item	Reference Page		
				VG33E only	VG33ER only	
NOT USED NOT USED	Maximum speed not attained. Acceleration poor.	ON vehicle	1. Fluid level	AT-62		GI
			2. Park/neutral position (PNP) switch adjustment	AT-270		MA
			3. Shift solenoid valve A	AT-169		EM
			4. Shift solenoid valve B	AT-174		
			5. Control valve assembly	AT-267		LC
		OFF vehicle	6. Reverse clutch	AT-306		
			7. High clutch	AT-310		EC
			8. Brake band	AT-341		
			9. Low & reverse brake	AT-316		FE
			10. Oil pump	AT-289		
			11. Torque converter	AT-278		CL
	Transmission noise in D, 2, 1 and R positions.	ON vehicle	1. Fluid level	AT-62		MT
		ON vehicle	2. Torque converter	AT-278		
	Engine brake does not operate in "1" position. AT-248	ON vehicle	1. Park/neutral position (PNP) switch adjustment	AT-270		AT
			2. Manual control linkage adjustment	AT-270		TF
3. Throttle position sensor (Adjustment)			EC-701	EC-1273		
4. Vehicle speed sensor-A/T (Revolution sensor) and vehicle speed sensor-MTR			AT-116, 199		PD	
5. Shift solenoid valve A			AT-169		AX	
6. Control valve assembly			AT-267			
7. Overrun clutch solenoid valve			AT-188		SU	
OFF vehicle		8. Overrun clutch	AT-312			
		9. Low & reverse brake	AT-316		BR	

TROUBLE DIAGNOSIS — GENERAL DESCRIPTION

Symptom Chart (Cont'd)

Items	Symptom	Condition	Diagnostic Item	Reference Page	
				VG33E only	VG33ER only
NOT USED NOT USED	Transmission overheats.	ON vehicle	1. Fluid level	AT-62	
			2. Engine idling rpm	EC-648	EC-1220
			3. Throttle position sensor (Adjustment)	EC-701	EC-1273
			4. Line pressure test	AT-65	
			5. Line pressure solenoid valve	AT-164	
			6. Control valve assembly	AT-267	
		OFF vehicle	7. Oil pump	AT-289	
			8. Reverse clutch	AT-306	
			9. High clutch	AT-310	
			10. Brake band	AT-341	
			11. Forward clutch	AT-312	
			12. Overrun clutch	AT-312	
			13. Low & reverse brake	AT-316	
			14. Torque converter	AT-278	
	ATF shoots out during operation. White smoke emitted from exhaust pipe during operation.	ON vehicle	1. Fluid level	AT-62	
		OFF vehicle	2. Reverse clutch	AT-306	
			3. High clutch	AT-310	
			4. Brake band	AT-341	
			5. Forward clutch	AT-312	
			6. Overrun clutch	AT-312	
			7. Low & reverse brake	AT-316	
	Offensive smell at fluid charging pipe.	ON vehicle	1. Fluid level	AT-62	
		OFF vehicle	2. Torque converter	AT-278	
			3. Oil pump	AT-289	
			4. Reverse clutch	AT-306	
			5. High clutch	AT-310	
			6. Brake band	AT-341	
			7. Forward clutch	AT-312	
8. Overrun clutch			AT-312		
9. Low & reverse brake			AT-316		
Engine is stopped at R, D, 2 and 1 positions.	ON vehicle	1. Fluid level	AT-62		
		2. Torque converter clutch solenoid valve	AT-152		
		3. Shift solenoid valve B	AT-174		
		4. Shift solenoid valve A	AT-169		
		5. Control valve assembly	AT-267		

TROUBLE DIAGNOSIS — GENERAL DESCRIPTION

TCM Terminals and Reference Value

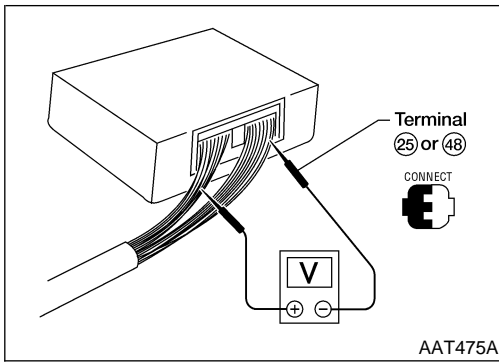

TCM Terminals and Reference Value

=NGAT0027

PREPARATION

NGAT0027S01

- Measure voltage between each terminal and terminal 25 or 48 by following "TCM INSPECTION TABLE".

TCM HARNESS CONNECTOR TERMINAL LAYOUT

NGAT0027S02

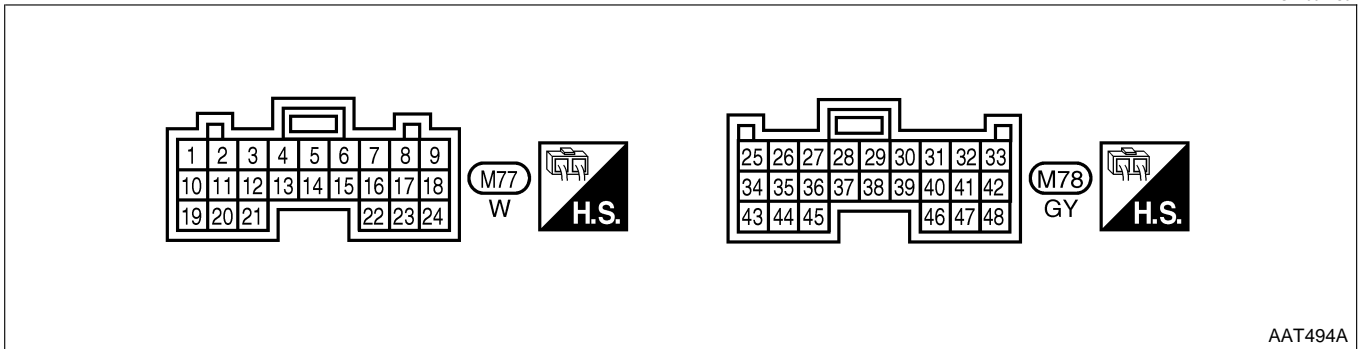

TCM INSPECTION TABLE









NGAT0027S03

(Data are reference values.)

Terminal No.	Wire color	Item	Condition	Judgement standard (Approx.)
1	GY/R	Line pressure solenoid valve	When releasing accelerator pedal after warming up engine.	1.5 - 2.5V
			When depressing accelerator pedal fully after warming up engine.	0V
2	BR/Y	Line pressure solenoid valve (with dropping resistor)	When releasing accelerator pedal after warming up engine.	5 - 14V
			When depressing accelerator pedal fully after warming up engine.	0V
3	G/OR	Torque converter clutch solenoid valve	When A/T performs lock-up	Battery voltage
			When A/T does not performs lock-up	0V
5*1	PU/W	DT1	—	—
6*1	P/B	DT2	—	—
7*1	G/R	DT3	—	—
10	W/R	Power source	When turning ignition ON.	Battery voltage
			When turning ignition OFF.	0V



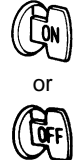



TROUBLE DIAGNOSIS — GENERAL DESCRIPTION

TCM Terminals and Reference Value (Cont'd)

Terminal No.	Wire color	Item	Condition		Judgement standard (Approx.)
11	L/W	Shift solenoid valve A		When shift solenoid valve A operates. (When driving in D ₁ or D ₄ .)	Battery voltage
				When shift solenoid valve A does not operate. (When driving in D ₂ or D ₃ .)	0V
12	L/Y	Shift solenoid valve B		When shift solenoid valve B operates. (When driving in D ₁ or D ₂ .)	Battery voltage
				When shift solenoid valve B does not operate. (When driving in D ₃ or D ₄ .)	0V
13	Y	O/D OFF indicator lamp		When setting overdrive control switch in OFF position.	0V
				When setting overdrive control switch in ON position.	Battery voltage
15*1	Y/G	OBD-II	—	—	—
16	BR/W	Closed throttle position switch (in throttle position switch)		When releasing accelerator pedal after warming up engine.	Battery voltage
				When depressing accelerator pedal after warming up engine.	0V
17	OR/B	Wide open throttle position switch (in throttle position switch)		When depressing accelerator pedal more than half-way after warming up engine.	Battery voltage
				When releasing accelerator pedal after warming up engine.	0V
18	B/Y	ASCD cruise signal		When ASCD cruise is being performed. ("CRUISE" light comes on.)	Battery voltage
				When ASCD cruise is not being performed. ("CRUISE" light does not come on.)	0V
19	W/R	Power source (same as No. 10)		When turning ignition ON.	Battery voltage
				When turning ignition OFF.	0V
20	L/B	Overrun clutch solenoid valve		When overrun clutch solenoid valve operates.	Battery voltage
				When overrun clutch shift solenoid valve does not operate.	0V
22	R	Overdrive control switch		When setting overdrive control switch in OFF position	0V
				When setting overdrive control switch in ON position	Battery voltage

TROUBLE DIAGNOSIS — GENERAL DESCRIPTION

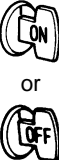

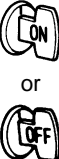







TCM Terminals and Reference Value (Cont'd)

Terminal No.	Wire color	Item	Condition		Judgement standard (Approx.)
24	GY	ASCD O/D cut signal		When ASCD permits O/D.	5 - 8V
				When ASCD requires O/D to be OFF.	0V
25	B/Y	Ground		—	0V
26	G/B	PNP switch 1 position		When setting selector lever to 1 position.	Battery voltage
				When setting selector lever to other position.	0V
27	G/W	PNP switch 2 position		When setting selector lever to 2 position.	Battery voltage
				When setting selector lever to other position.	0V
28	R/Y	Power source (Memory back-up)		When turning ignition switch to ON.	Battery voltage
				When turning ignition switch to OFF.	Battery voltage
29	B/R	Revolution sensor (Measure in AC range)		When vehicle cruises at 30 km/h (19 MPH).	1V or more Voltage rises gradually in response to vehicle speed.
				When vehicle parks.	0V
30*2	Y/R	DATA LINK CONNECTOR data in	—	—	—
31*2	GY/L	DATA LINK CONNECTOR data out	—	—	—
32	B/W	Throttle position sensor (Power source)		Ignition switch ON.	4.5 - 5.5V
				Ignition switch OFF.	0V

GI
MA
EM
LC
EC
FE
CL
MT
AT
TF
PD
AX
SU
BR
ST
RS
BT
HA
SC
EL
IDX

TROUBLE DIAGNOSIS — GENERAL DESCRIPTION

TCM Terminals and Reference Value (Cont'd)

Terminal No.	Wire color	Item	Condition		Judgement standard (Approx.)
34	L	PNP switch D position		When setting selector lever to D position.	Battery voltage
				When setting selector lever to other position.	0V
35	Y/R	PNP switch R position		When setting selector lever to R position.	Battery voltage
				When setting selector lever to other position.	0V
36	P	PNP switch P or N position		When setting selector lever to P or N position.	Battery voltage
				When setting selector lever to other position.	0V
38*3	Y	Turbine revolution sensor (measured in AC range)		When engine runs at approximately 1,000 rpm.	1.2 V
39	P/L	Engine speed signal		When engine runs at idle speed.	0.5 - 2.5V
40	G/B	Vehicle speed sensor		When moving vehicle at 2 to 3 km/h (1 to 2 MPH) for 1m (3 ft) or more.	Voltage varies between less than 1V and more than 4.5V
41	OR/L	Throttle position sensor		When depressing accelerator pedal slowly after warming up engine. (Voltage rises gradually in response to throttle position.)	Fully-closed throttle: 0.5V Fully-open throttle: 4V
42	BR	Throttle position sensor (Ground)	—	—	0V
45*3	BR/R	Stoplamp switch		When brake pedal is depressed.	Battery voltage
				When brake pedal is released.	0V
47	R/B	A/T fluid temperature sensor		When ATF temperature is 20°C (68°F).	1.5V
				When ATF temperature is 80°C (176°F).	0.5V
48	B/Y	Ground (same as No. 25)		—	0V

*1: These terminals are connected to the ECM.

*2: These terminals are connected to the Data Link Connector.

*3: VG33ER only.

TROUBLE DIAGNOSIS FOR POWER SUPPLY

Wiring Diagram — AT — MAIN

Wiring Diagram — AT — MAIN

NGAT0185

AT-MAIN-01

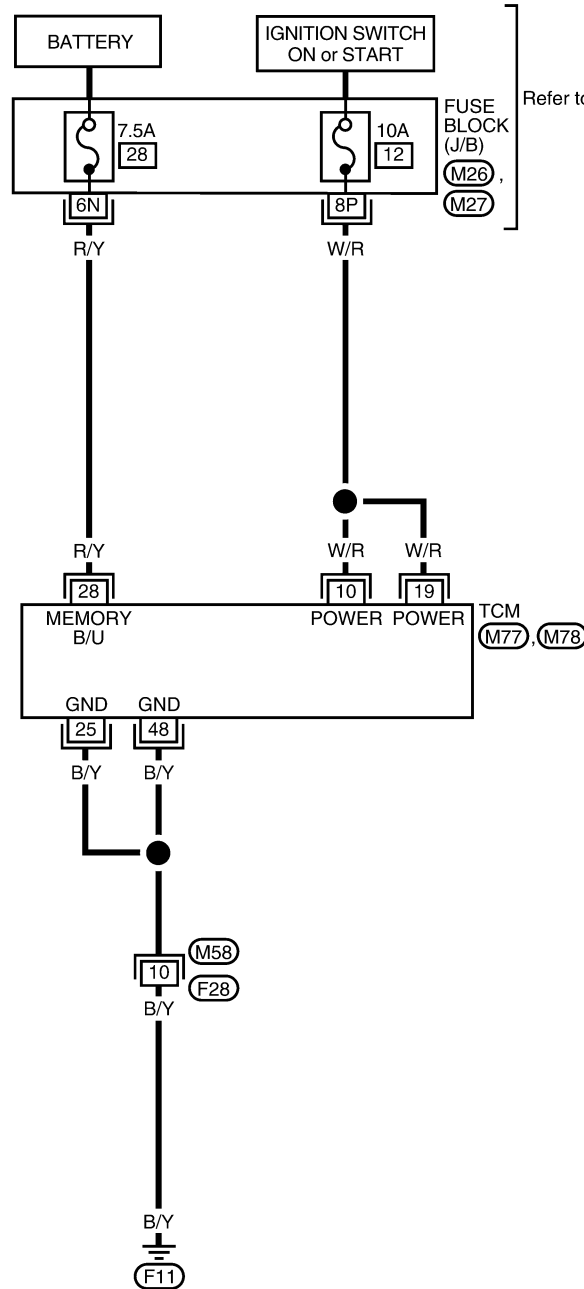

Refer to "EL-POWER".

- : Detectable line for DTC
- : Non-detectable line for DTC
- DL : With power door locks
- OD : Without power door locks

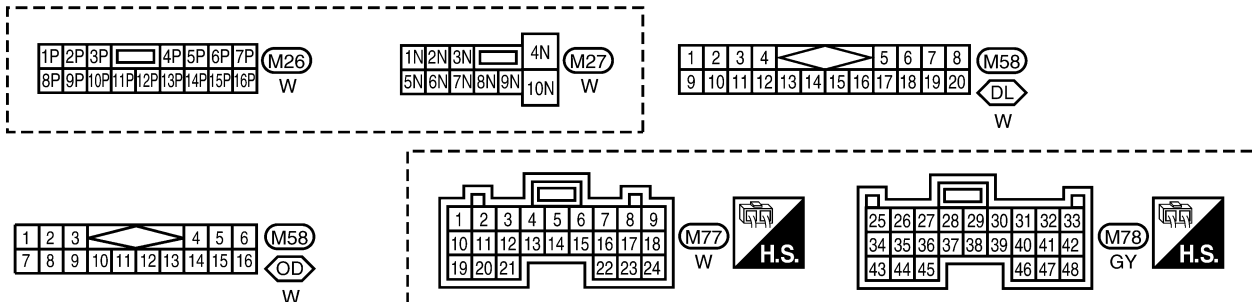

WAT518

GI
MA
EM
LC
EC
FE
CL
MT
AT
TF
PD
AX
SU
BR
ST
RS
BT
HA
SC
EL
IDX





TROUBLE DIAGNOSIS FOR POWER SUPPLY

Wiring Diagram — AT — MAIN (Cont'd)

TCM TERMINALS AND REFERENCE VALUE

NGAT0185S01

Remarks: Specification data are reference values.

Terminal No.	Wire color	Item	Condition		Judgement standard (Approx.)
10	W/R	Power source		When turning ignition switch to ON	Battery voltage
				When turning ignition switch to OFF	0V
19	W/R	Power source		Same as No. 10	
25	B/Y	Ground	—	—	0V
28	R/Y	Power source (Memory back-up)		When turning ignition switch to OFF	Battery voltage
				When turning ignition switch to ON	Battery voltage
48	B/Y	Ground (same as No. 25)	or 	When turning ignition switch to OFF	0V
				When turning ignition switch to ON	0V

Diagnostic Procedure

NGAT0209

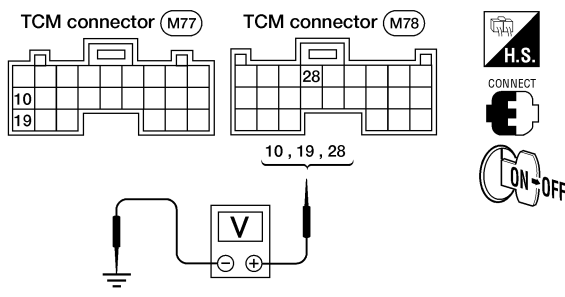
1	CHECK TCM POWER SOURCE
<p>1. Turn ignition switch to ON position. (Do not start engine.)</p> <p>2. Check voltage between TCM terminals (10, 19, 28) and ground.</p> <div style="text-align: center;">  </div> <p style="text-align: right;">Voltage: Battery voltage</p> <p>3. Turn ignition switch to OFF position.</p> <p>4. Check voltage between TCM terminal 28 and ground.</p> <p style="text-align: right;">Voltage: Battery voltage</p> <p style="text-align: center;">OK or NG</p>	
OK	▶ GO TO 2.
NG	▶ Check the following items: <ul style="list-style-type: none"> ● Harness for short or open between ignition switch and TCM terminals 10, 19 and 28 (Main harness) ● Ignition switch and fuse Refer to "POWER SUPPLY ROUTING", <i>EL-10</i> .

AAT476A

TROUBLE DIAGNOSIS FOR POWER SUPPLY

Diagnostic Procedure (Cont'd)

2	CHECK TCM GROUND CIRCUIT	
	<p>1. Turn ignition switch to OFF position.</p> <p>2. Disconnect TCM harness connector.</p> <p>3. Check continuity between terminals (25, 48) and ground. Refer to wiring diagrams.</p> <p style="padding-left: 20px;">Continuity should exist.</p> <p style="padding-left: 20px;">If OK, check harness for short to ground and short to power.</p> <p style="text-align: center;">OK or NG</p>	
OK	▶	INSPECTION END
NG	▶	Repair open circuit or short to ground or short to power in harness or connectors.

GI
MA
EM
LC
EC
FE
CL
MT
AT
TF
PD
AX
SU
BR
ST
RS
BT
HA
SC
EL
IDX

DTC P0705 PARK/NEUTRAL POSITION (PNP) SWITCH

Description

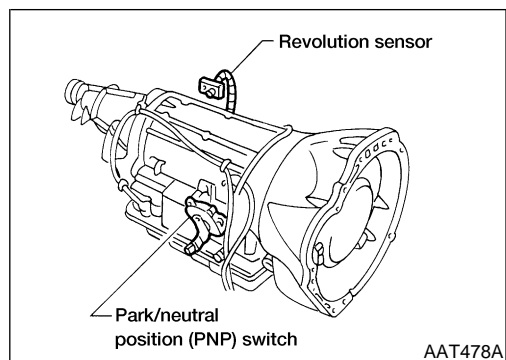

Description

- The PNP switch assembly includes a transmission range switch. NGAT0028
- The transmission range switch detects the selector position and sends a signal to the TCM.

TCM TERMINALS AND REFERENCE VALUE

NGAT0028S02

Remarks: Specification data are reference values.

Terminal No.	Wire color	Item	Condition	Judgement standard (Approx.)
26	G/B	PNP switch 1 position	When setting selector lever to 1 position.	Battery voltage
			When setting selector lever to other positions.	0V
27	G/W	PNP switch 2 position	When setting selector lever to 2 position.	Battery voltage
			When setting selector lever to other positions.	0V
34	L	PNP switch D position	When setting selector lever to D position.	Battery voltage
			When setting selector lever to other positions.	0V
35	Y	PNP switch R position	When setting selector lever to R position.	Battery voltage
			When setting selector lever to other positions.	0V
36	P	PNP switch P or N position	When setting selector lever to P or N position.	Battery voltage
			When setting selector lever to other positions.	0V



ON BOARD DIAGNOSIS LOGIC

NGAT0028S03

Diagnostic trouble code	Malfunction is detected when ...	Check item (Possible cause)
ⓘ : PNP SW/CIRC ⓘ : P0705	TCM does not receive the correct voltage signal from the switch based on the gear position.	<ul style="list-style-type: none"> • Harness or connectors (The PNP switch circuit is open or shorted.) • PNP switch

DTC P0705 PARK/NEUTRAL POSITION (PNP) SWITCH

Description (Cont'd)

SELECT SYSTEM
A/T
ENGINE

SAT014K

SELECT DIAG MODE
WORK SUPPORT
SELF-DIAG RESULTS
DATA MONITOR
DATA MONITOR (SPEC)
ACTIVE TEST
DTC & SRT CONFIRMATION

SEF949Y

DIAGNOSTIC TROUBLE CODE (DTC) CONFIRMATION PROCEDURE

NGAT0028S01

CAUTION:

Always drive vehicle at a safe speed.

NOTE:

If "DIAGNOSTIC TROUBLE CODE CONFIRMATION PROCEDURE" has been previously conducted, always turn ignition switch OFF and wait at least 5 seconds before conducting the next test.

After the repair, perform the following procedure to confirm the malfunction is eliminated.

Ⓜ With CONSULT-II

- 1) Turn ignition switch ON.
- 2) Select "DATA MONITOR" mode for "ENGINE" with CONSULT-II.
- 3) Start engine and maintain the following conditions for at least 5 consecutive seconds.

VHCL SPEED SE: 10 km/h (6 MPH) or more

THRTL POS SEN: More than 1.3V

Selector lever: D position (O/D ON or OFF)

Ⓜ With GST

Follow the procedure "With CONSULT-II".

GI

MA

EM

LC

EC

FE

CL

MT

AT

TF

PD

AX

SU

BR

ST

RS

BT

HA

SC

EL

IDX

DTC P0705 PARK/NEUTRAL POSITION (PNP) SWITCH

Wiring Diagram — AT — PNP/SW

Wiring Diagram — AT — PNP/SW

NGAT0186

AT-PNP/SW-01

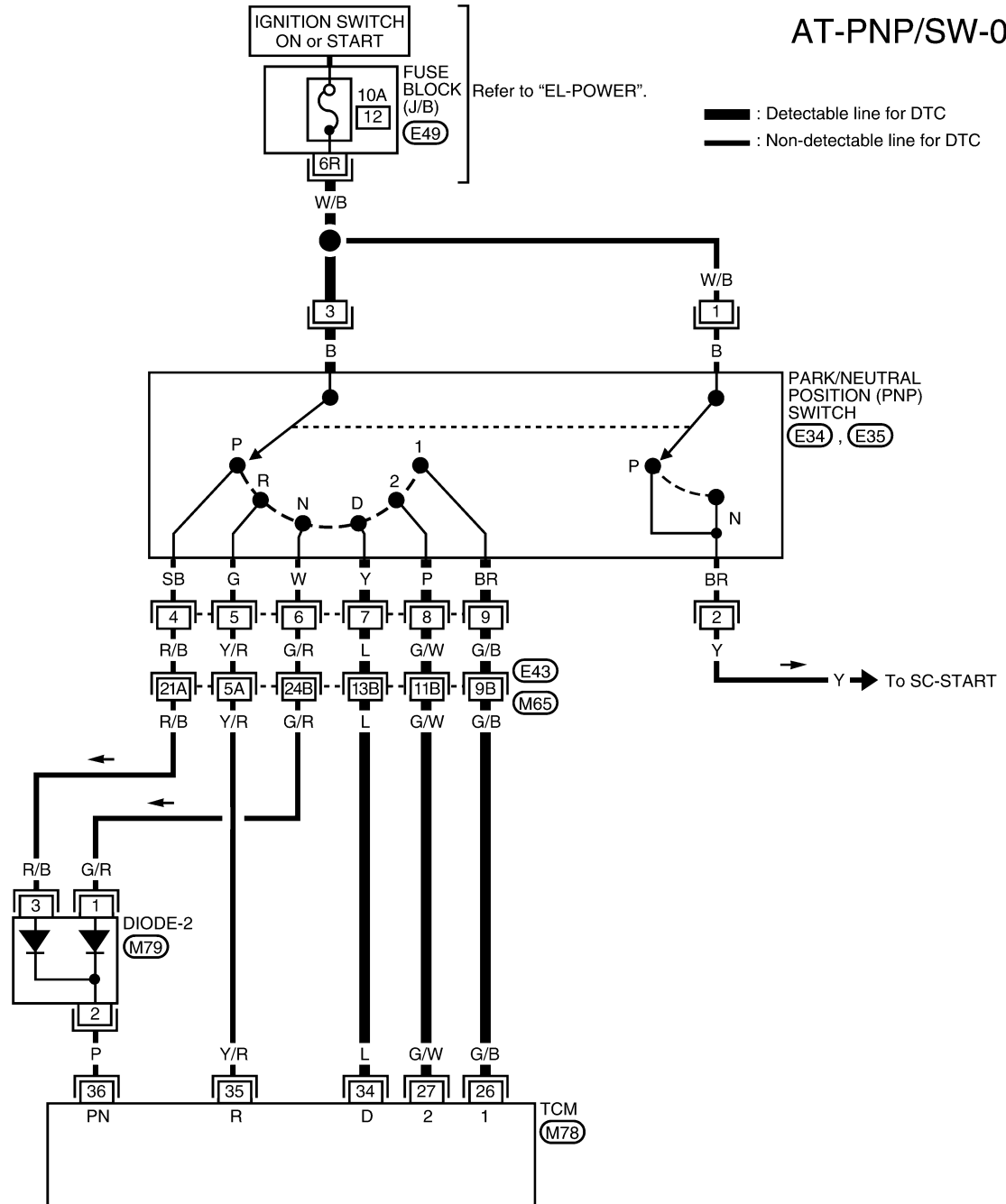

: Detectable line for DTC
 : Non-detectable line for DTC

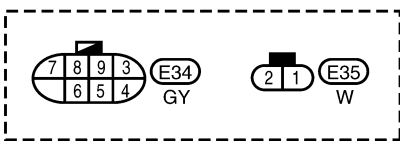
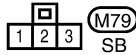
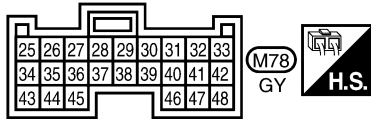

Refer to the following.
 M65, E43 - SUPER
 MULTIPLE JUNCTION (SMJ)

WAT510

DTC P0705 PARK/NEUTRAL POSITION (PNP) SWITCH

Diagnostic Procedure

Diagnostic Procedure

NGAT0029

1	CHECK PNP SWITCH CIRCUIT (With CONSULT-II)															
	<p> With CONSULT</p> <ol style="list-style-type: none"> 1. Turn ignition switch to ON position. (Do not start engine.) 2. Select "TCM INPUT SIGNALS" in "DATA MONITOR" mode for "A/T" with CONSULT-II. 3. Read out P, R, N, D, 2 and 1 position switches moving selector lever to each position. Check the signal of the selector lever position is indicated properly. 															
	<table border="1" style="margin: auto;"> <thead> <tr> <th colspan="2">DATA MONITOR</th> </tr> <tr> <th>MONITORING</th> <th></th> </tr> </thead> <tbody> <tr> <td>PN POSI SW</td> <td>OFF</td> </tr> <tr> <td>R POSITION SW</td> <td>OFF</td> </tr> <tr> <td>D POSITION SW</td> <td>OFF</td> </tr> <tr> <td>2 POSITION SW</td> <td>ON</td> </tr> <tr> <td>1 POSITION SW</td> <td>OFF</td> </tr> </tbody> </table>		DATA MONITOR		MONITORING		PN POSI SW	OFF	R POSITION SW	OFF	D POSITION SW	OFF	2 POSITION SW	ON	1 POSITION SW	OFF
DATA MONITOR																
MONITORING																
PN POSI SW	OFF															
R POSITION SW	OFF															
D POSITION SW	OFF															
2 POSITION SW	ON															
1 POSITION SW	OFF															
	SAT643J															
	OK or NG															
OK	▶	GO TO 3.														
NG	▶	<p>Check the following items:</p> <ul style="list-style-type: none"> ● PNP switch Refer to "Component Inspection", AT-109. ● Harness for short or open between ignition switch and PNP switch (Main harness) ● Harness for short or open between PNP switch and TCM (Main harness) ● Diode (P, N positions) 														

GI
MA
EM
LC
EC
FE
CL
MT
AT
TF
PD
AX
SU
BR
ST
RS
BT
HA
SC
EL
IDX

DTC P0705 PARK/NEUTRAL POSITION (PNP) SWITCH

Diagnostic Procedure (Cont'd)

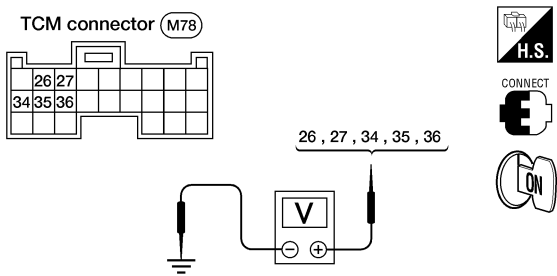
2	CHECK PNP SWITCH CIRCUIT (Without CONSULT-II)																																									
<p>⊗ Without CONSULT-II</p> <ol style="list-style-type: none"> Turn ignition switch to ON position. (Do not start engine.) Check voltage between TCM connector M78 terminals (26, 27, 34, 35, 36) and ground, while moving selector lever through each position. 																																										
																																										
AAT480A																																										
<table border="1" style="margin: auto; border-collapse: collapse;"> <thead> <tr> <th rowspan="2">Lever position</th> <th colspan="5">Terminals</th> </tr> <tr> <th>36</th> <th>35</th> <th>34</th> <th>27</th> <th>26</th> </tr> </thead> <tbody> <tr> <td>P, N</td> <td>B</td> <td>0</td> <td>0</td> <td>0</td> <td>0</td> </tr> <tr> <td>R</td> <td>0</td> <td>B</td> <td>0</td> <td>0</td> <td>0</td> </tr> <tr> <td>D</td> <td>0</td> <td>0</td> <td>B</td> <td>0</td> <td>0</td> </tr> <tr> <td>2</td> <td>0</td> <td>0</td> <td>0</td> <td>B</td> <td>0</td> </tr> <tr> <td>1</td> <td>0</td> <td>0</td> <td>0</td> <td>0</td> <td>B</td> </tr> </tbody> </table>		Lever position	Terminals					36	35	34	27	26	P, N	B	0	0	0	0	R	0	B	0	0	0	D	0	0	B	0	0	2	0	0	0	B	0	1	0	0	0	0	B
Lever position	Terminals																																									
	36	35	34	27	26																																					
P, N	B	0	0	0	0																																					
R	0	B	0	0	0																																					
D	0	0	B	0	0																																					
2	0	0	0	B	0																																					
1	0	0	0	0	B																																					
AAT479A																																										
Does battery voltage exist (B) or non-existent (0)?																																										
Yes	▶	GO TO 3.																																								
No	▶	<p>Check the following items:</p> <ul style="list-style-type: none"> ● PNP switch Refer to "Component Inspection", AT-109. ● Harness for short or open between ignition switch and PNP switch (Main harness) ● Harness for short or open between PNP switch and TCM (Main harness) ● Diode (P, N positions) 																																								

3	CHECK DTC	
Perform Diagnostic Trouble Code (DTC) confirmation procedure, AT-105.		
OK or NG		
OK	▶	INSPECTION END
NG	▶	<ol style="list-style-type: none"> Perform TCM input/output signal inspection. If NG, recheck TCM pin terminals for damage or loose connection with harness connector.

DTC P0705 PARK/NEUTRAL POSITION (PNP) SWITCH

Component Inspection

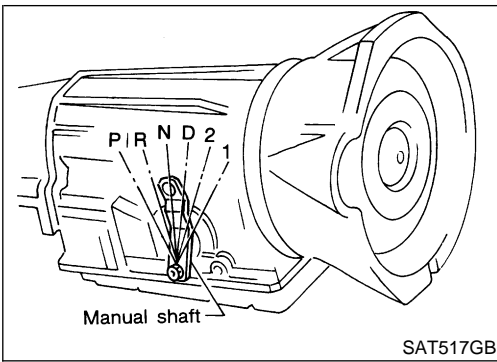

Component Inspection PNP SWITCH

NGAT0030

NGAT0030S02

1. Check continuity between terminals 1 and 2 and between terminals 3 and (4, 5, 6, 7, 8, 9) while moving manual shaft through each position.

Lever position	P	R	N	D	2	1
Terminal No.	1 - 2	3 - 5	1 - 2	3 - 7	3 - 8	3 - 9
	3 - 4		3 - 6			

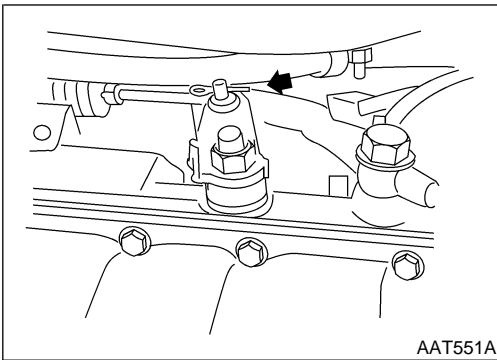
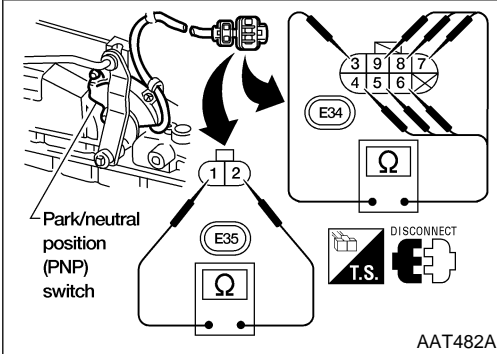

2. If NG, check again with manual control linkage disconnected from manual shaft of A/T assembly. Refer to step 1.
3. If OK on step 2, adjust manual control linkage. Refer to AT-270.

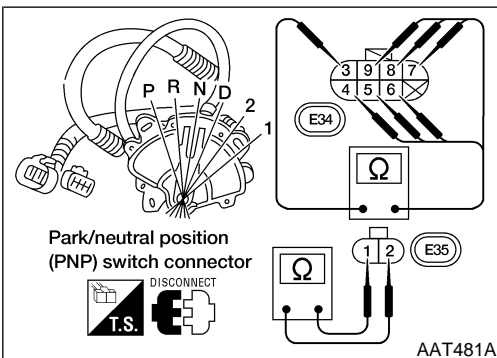

4. If NG on step 2, remove PNP switch from A/T and check continuity of PNP switch terminals. Refer to step 1.
5. If OK on step 4, adjust PNP switch. Refer to AT-270.
6. If NG on step 4, replace PNP switch.

GI
MA
EM
LC
EC
FE
CL
MT
AT
TF
PD
AX
SU
BR
ST
RS
BT
HA
SC
EL
IDX

DTC P0710 A/T FLUID TEMPERATURE SENSOR CIRCUIT

Description

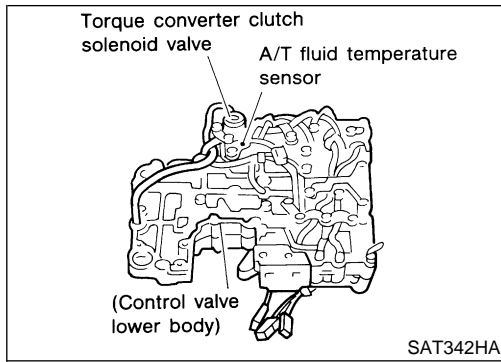

Description

The A/T fluid temperature sensor detects the A/T fluid temperature and sends a signal to the TCM. NGAT0031

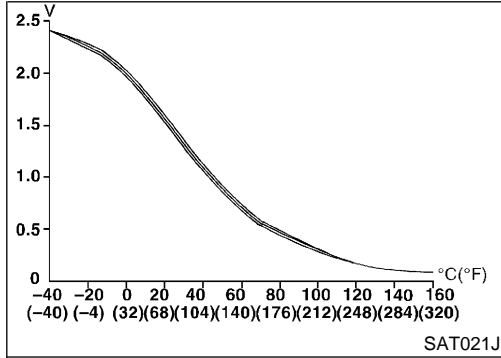

CONSULT-II REFERENCE VALUE IN DATA MONITOR MODE

Remarks: Specification data are reference values. NGAT0031S04

Monitor item	Condition	Specification (Approx.)	
A/T fluid temperature sensor	Cold [20°C (68°F)]	1.5V	2.5 kΩ
	Hot [80°C (176°F)]	0.5V	0.3 kΩ

TCM TERMINALS AND REFERENCE VALUE

Remarks: Specification data are reference values. NGAT0031S02

Terminal No.	Wire color	Item	Condition	Judgement standard (Approx.)
42	BR	Throttle position sensor (Ground)		—
47	R/B	A/T fluid temperature sensor		When ATF temperature is 20°C (68°F). When ATF temperature is 80°C (176°F).

ON BOARD DIAGNOSIS LOGIC

Diagnostic trouble code	Malfunction is detected when ...	Check item (Possible cause)
(P) : ATF TEMP SEN/CIRC (P) : P0710	TCM receives an excessively low or high voltage from the sensor.	<ul style="list-style-type: none"> Harness or connectors (The sensor circuit is open or shorted.) A/T fluid temperature sensor

DTC P0710 A/T FLUID TEMPERATURE SENSOR CIRCUIT

Description (Cont'd)

SELECT SYSTEM
A/T
ENGINE

SAT014K

SELECT DIAG MODE
WORK SUPPORT
SELF-DIAG RESULTS
DATA MONITOR
DATA MONITOR (SPEC)
ACTIVE TEST
DTC & SRT CONFIRMATION

SEF949Y

DIAGNOSTIC TROUBLE CODE (DTC) CONFIRMATION PROCEDURE

NGAT0031S01

CAUTION:

Always drive vehicle at a safe speed.

NOTE:

If "DIAGNOSTIC TROUBLE CODE CONFIRMATION PROCEDURE" has been previously conducted, always turn ignition switch OFF and wait at least 5 seconds before conducting the next test.

After the repair, perform the following procedure to confirm the malfunction is eliminated.

With CONSULT-II

- 1) Turn ignition switch ON and select "DATA MONITOR" mode for "ENGINE" with CONSULT-II.
- 2) Start engine and maintain the following conditions for at least 10 minutes (Total). (It is not necessary to maintain continuously.)

CMPS-RPM (REF): 450 rpm or more

VHCL SPEED SE: 10 km/h (6 MPH) or more

THRTL POS SEN: More than 1.2V

Selector lever: D position (O/D ON)

With GST

Follow the procedure "With CONSULT-II".

GI

MA

EM

LC

EC

FE

CL

MT

AT

TF

PD

AX

SU

BR

ST

RS

BT

HA

SC

EL

IDX

DTC P0710 A/T FLUID TEMPERATURE SENSOR CIRCUIT

Wiring Diagram — AT — FTS

Wiring Diagram — AT — FTS

NGAT0187

AT-FTS-01

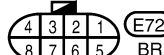
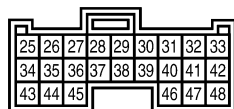
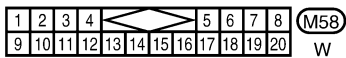
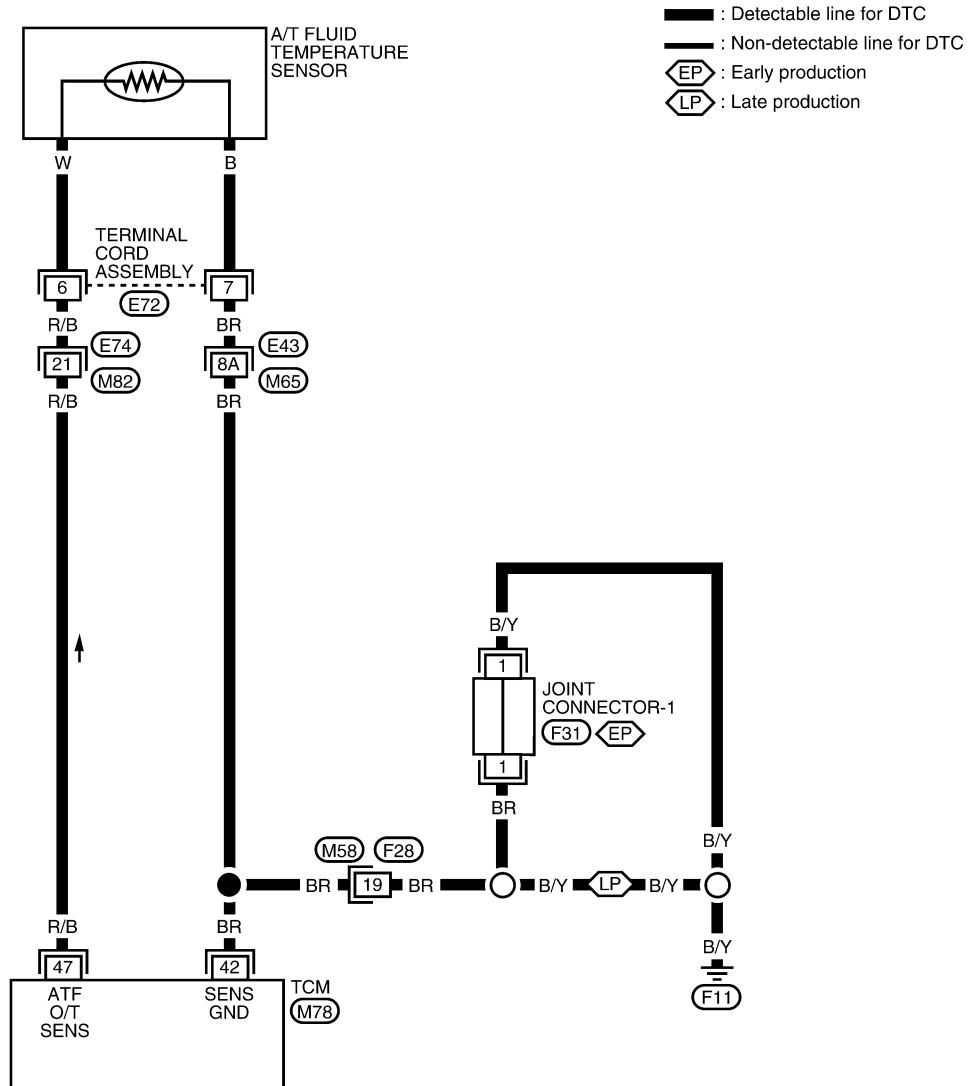

Refer to the following.
E43 - SUPER MULTIPLE JUNCTION (SMJ)
F31 - JOINT CONNECTOR

WAT542

DTC P0710 A/T FLUID TEMPERATURE SENSOR CIRCUIT

Diagnostic Procedure

Diagnostic Procedure

NGAT0032

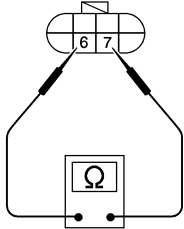
1	CHECK A/T FLUID TEMPERATURE SENSOR WITH TERMINAL CORD ASSEMBLY	
	<p>1. Turn ignition switch to OFF position. 2. Disconnect terminal cord assembly connector in engine compartment. 3. Check resistance between terminal cord assembly connector E72 terminals 6 and 7, when A/T is cold [20°C (68°F)].</p> <div style="text-align: center;"> <p>Terminal cord assembly connector (E72)</p>  <p>The diagram shows a terminal cord assembly connector with terminals 6 and 7. Wires from these terminals are connected to an ohmmeter (represented by a box with the Greek letter Ω). To the right of the diagram is a 'T.S. DISCONNECT' symbol, which is a square with a diagonal line and a gear-like shape below it.</p> </div> <p style="text-align: right;">AAT483A</p>	
	Is resistance approx. 2.5 kΩ?	
Yes	▶	GO TO 2.
No	▶	<p>1. Remove oil pan. 2. Check the following items:</p> <ul style="list-style-type: none"> ● A/T fluid temperature sensor Refer to "Component Inspection", AT-115. ● Harness of terminal cord assembly for short or open

GI
MA
EM
LC
EC
FE
CL
MT
AT
TF
PD
AX
SU
BR
ST
RS
BT
HA
SC
EL
IDX

DTC P0710 A/T FLUID TEMPERATURE SENSOR CIRCUIT

Diagnostic Procedure (Cont'd)

2	CHECK INPUT SIGNAL OF A/T FLUID TEMPERATURE SENSOR															
<p>Ⓜ With CONSULT-II</p> <ol style="list-style-type: none"> Start engine. Select "TCM INPUT SIGNALS" in "DATA MONITOR" mode for "A/T" with CONSULT-II. Read out the value of "FLUID TEMP SE". <p>Voltage: Cold [20°C (68°F)] → Hot [80°C (176°F)]: Approximately 1.5V → 0.5V</p> <table border="1" style="margin-left: auto; margin-right: auto;"> <thead> <tr> <th colspan="2">DATA MONITOR</th> </tr> <tr> <th>MONITORING</th> <th></th> </tr> </thead> <tbody> <tr> <td>VHCL/S SE-A/T</td> <td>XXX km/h</td> </tr> <tr> <td>VHCL/S SE-MTR</td> <td>XXX km/h</td> </tr> <tr> <td>THRTL POS SEN</td> <td>XXX V</td> </tr> <tr> <td>FLUID TEMP SE</td> <td>XXX V</td> </tr> <tr> <td>BATTERY VOLT</td> <td>XXX V</td> </tr> </tbody> </table> <p style="text-align: right;">SAT614J</p>			DATA MONITOR		MONITORING		VHCL/S SE-A/T	XXX km/h	VHCL/S SE-MTR	XXX km/h	THRTL POS SEN	XXX V	FLUID TEMP SE	XXX V	BATTERY VOLT	XXX V
DATA MONITOR																
MONITORING																
VHCL/S SE-A/T	XXX km/h															
VHCL/S SE-MTR	XXX km/h															
THRTL POS SEN	XXX V															
FLUID TEMP SE	XXX V															
BATTERY VOLT	XXX V															
<p>ⓧ Without CONSULT-II</p> <ol style="list-style-type: none"> Start engine. Check voltage between TCM connector M78 terminal 47 and ground while warming up A/T. <div style="text-align: center;"> </div> <p>Voltage: Cold [20°C (68°F)] → Hot [80°C (176°F)]: Approximately 1.5V → 0.5V</p> <p style="text-align: center;">OK or NG</p> <p style="text-align: right;">AAT484A</p>																
OK	▶	GO TO 3.														
NG	▶	<p>Check the following item:</p> <ul style="list-style-type: none"> Harness for short or open between TCM and terminal cord assembly (Main harness) 														

3	CHECK DTC	
<p>Perform Diagnostic Trouble Code (DTC) confirmation procedure. Refer to "DIAGNOSTIC TROUBLE CODE (DTC) CONFIRMATION PROCEDURE", AT-111.</p> <p style="text-align: center;">OK or NG</p>		
OK	▶	INSPECTION END
NG	▶	<ol style="list-style-type: none"> Perform TCM input/output signal inspection. If NG, recheck TCM pin terminals for damage or loose connection with harness connector.

DTC P0710 A/T FLUID TEMPERATURE SENSOR CIRCUIT

Component Inspection

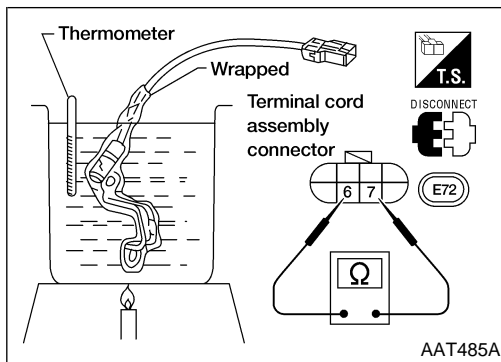

Component Inspection

A/T FLUID TEMPERATURE SENSOR

NGAT0033

NGAT0033S01

- For removal, refer to "REMOVAL", AT-267.
- Check resistance between terminals 6 and 7 while changing temperature as shown at left.

Temperature °C (°F)	Resistance
20 (68)	Approximately 2.5 kΩ
80 (176)	Approximately 0.3 kΩ

GI

MA

EM

LC

EC

FE

CL

MT

AT

TF

PD

AX

SU

BR

ST

RS

BT

HA

SC

EL

IDX

DTC P0720 VEHICLE SPEED SENSOR-A/T (REVOLUTION SENSOR)

Description

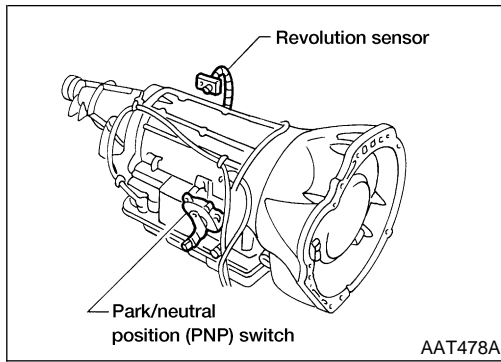



Description

The revolution sensor detects the revolution of the output shaft parking pawl lock gear and emits a pulse signal. The pulse signal is sent to the TCM which converts it into vehicle speed. NGAT0034

TCM TERMINALS AND REFERENCE VALUE

NGAT0034S02

Remarks: Specification data are reference values.

Terminal No.	Wire color	Item	Condition	Judgement standard (Approx.)
29	B/R	Revolution sensor (Measure in AC range)	 When vehicle cruises at 30 km/h (19 MPH).	1V or more Voltage rises gradually in response to vehicle speed.
			When vehicle parks.	0V
42	BR	Throttle position sensor (Ground)	 —	0V

ON BOARD DIAGNOSIS LOGIC

NGAT0034S03

Diagnostic trouble code	Malfunction is detected when ...	Check item (Possible cause)
(P) : VEH SPD SEN/CIR AT (S) : P0720	TCM does not receive the proper voltage signal from the sensor.	<ul style="list-style-type: none"> • Harness or connectors (The sensor circuit is open or shorted.) • Revolution sensor

DTC P0720 VEHICLE SPEED SENSOR-A/T (REVOLUTION SENSOR)

Description (Cont'd)

SELECT SYSTEM
A/T
ENGINE

SAT014K

SELECT DIAG MODE
SELF-DIAG RESULTS
DATA MONITOR
DTC WORK SUPPORT
TCM PART NUMBER

SAT971J

SELECT SYSTEM
A/T
ENGINE

SAT014K

SELECT DIAG MODE
WORK SUPPORT
SELF-DIAG RESULTS
DATA MONITOR
DATA MONITOR (SPEC)
ACTIVE TEST
DTC & SRT CONFIRMATION

SEF949Y

DIAGNOSTIC TROUBLE CODE (DTC) CONFIRMATION PROCEDURE

NGAT0034S01

CAUTION:

- Always drive vehicle at a safe speed.
- Be careful not to rev engine into the red zone on the tachometer.

NOTE:

If "DIAGNOSTIC TROUBLE CODE CONFIRMATION PROCEDURE" has been previously conducted, always turn ignition switch OFF and wait at least 5 seconds before conducting the next test.

After the repair, perform the following procedure to confirm the malfunction is eliminated.

With CONSULT-II

- Turn ignition switch ON and select "DATA MONITOR" mode for "A/T" with CONSULT-II.
- Drive vehicle and check for an increase of "VHCL/S SE-MTR" value.
If the check result is NG, go to "DIAGNOSTIC PROCEDURE", AT-202.
If the check result is OK, go to following step.
- Select "DATA MONITOR" mode for "ENGINE" with CONSULT-II.
- Start engine and maintain the following conditions for at least 5 consecutive seconds.
VHCL SPEED SE: 30 km/h (19 MPH) or more
THRTL POS SEN: More than 1.2V
Selector lever: D position (O/D ON)
Driving condition: Driving the vehicle uphill (increased engine load) will help maintain the driving conditions required for this test.
If the check result is NG, go to "DIAGNOSTIC PROCEDURE", AT-119.
If the check result is OK, go to following step.
- Maintain the following conditions for at least 5 consecutive seconds.
CMPS-RPM (REF): 3,500 rpm or more
THRTL POS SEN: More than 1.2V
Selector lever: D position (O/D ON)
Driving condition: Driving the vehicle uphill (increased engine load) will help maintain the driving conditions required for this test.

With GST

Follow the procedure "With CONSULT-II".

GI
MA
EM
LC
EC
FE
CL
MT
AT
TF
PD
AX
SU
BR
ST
RS
BT
HA
SC
EL
IDX

DTC P0720 VEHICLE SPEED SENSOR-A/T (REVOLUTION SENSOR)

Wiring Diagram — AT — VSSA/T

Wiring Diagram — AT — VSSA/T

NGAT0188

AT-VSSA/T-01

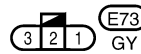
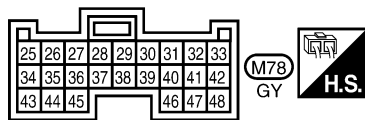
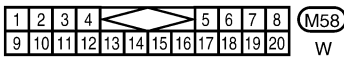
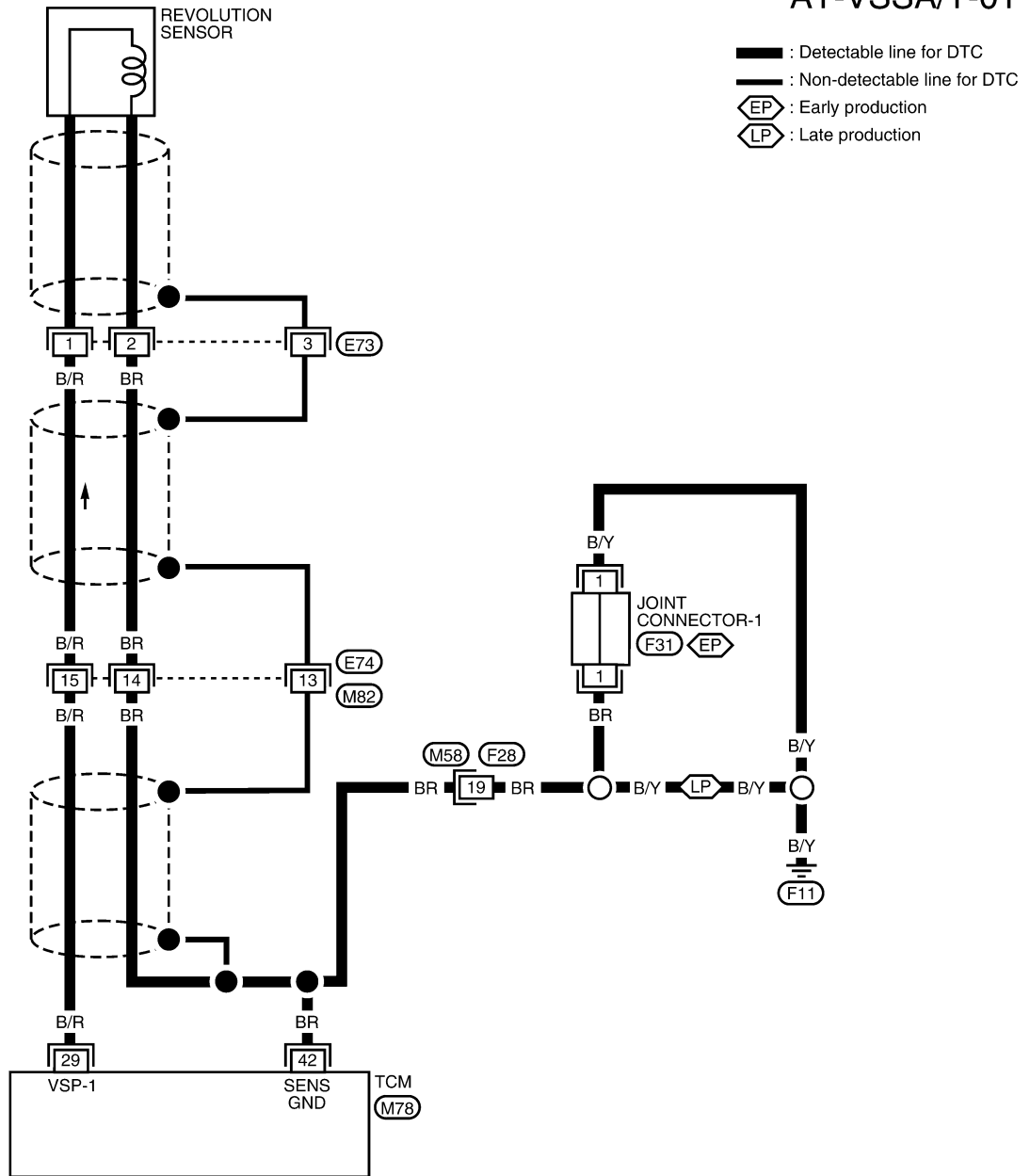

Refer to the following.
F31 - JOINT CONNECTOR

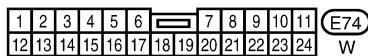

WAT543

DTC P0720 VEHICLE SPEED SENSOR-A/T (REVOLUTION SENSOR)

Diagnostic Procedure

Diagnostic Procedure

NGAT0035

1	CHECK REVOLUTION SENSOR	
Refer to "Component Inspection", AT-120.		
OK or NG		
OK	▶	GO TO 2.
NG	▶	Repair or replace revolution sensor.

GI
MA
EM

2	CHECK INPUT SIGNAL															
<p> With CONSULT-II</p> <ol style="list-style-type: none"> Start engine. Select "TCM INPUT SIGNALS" in "DATA MONITOR" mode for "A/T" with CONSULT-II. Read out the value of "VHCL/S SE-A/T" while driving. Check the value changes according to driving speed. 																
<table border="1"> <thead> <tr> <th colspan="2">DATA MONITOR</th> </tr> <tr> <th>MONITORING</th> <th></th> </tr> </thead> <tbody> <tr> <td>VHCL/S SE-A/T</td> <td>XXX km/h</td> </tr> <tr> <td>VHCL/S SE-MTR</td> <td>XXX km/h</td> </tr> <tr> <td>THRTL POS SEN</td> <td>XXX V</td> </tr> <tr> <td>FLUID TEMP SE</td> <td>XXX V</td> </tr> <tr> <td>BATTERY VOLT</td> <td>XXX V</td> </tr> </tbody> </table>			DATA MONITOR		MONITORING		VHCL/S SE-A/T	XXX km/h	VHCL/S SE-MTR	XXX km/h	THRTL POS SEN	XXX V	FLUID TEMP SE	XXX V	BATTERY VOLT	XXX V
DATA MONITOR																
MONITORING																
VHCL/S SE-A/T	XXX km/h															
VHCL/S SE-MTR	XXX km/h															
THRTL POS SEN	XXX V															
FLUID TEMP SE	XXX V															
BATTERY VOLT	XXX V															
SAT614J																

LC
EC
FE
CL
MT
AT

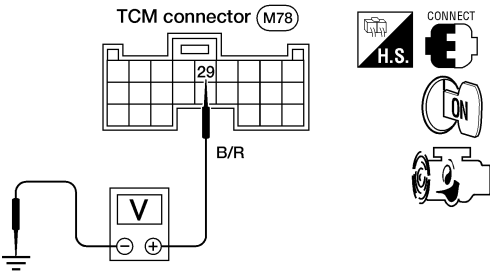
<p> Without CONSULT-II</p> <ol style="list-style-type: none"> Start engine. Check voltage between TCM connector M78 terminal 29 and ground while driving. (Measure with AC range.) 		
		
<p>Voltage:</p> <p>At 0 km/h (0 MPH): 0V</p> <p>At 30 km/h (19 MPH): 1V or more</p> <p>(Voltage rises gradually in response to vehicle speed.)</p>		
OK or NG		
OK	▶	GO TO 3.
NG	▶	<p>Check the following items:</p> <ul style="list-style-type: none"> Harness for short or open between TCM and revolution sensor (Main harness) Harness for short or open between revolution sensor and ECM (Main harness) Ground circuit for ECM <p>Refer to EC-740, "TROUBLE DIAGNOSIS FOR POWER SUPPLY".</p>

TF
PD
AX
SU
BR
ST
RS
BT
HA
SC

AAT486A

EL
IDX

DTC P0720 VEHICLE SPEED SENSOR-A/T (REVOLUTION SENSOR)

Diagnostic Procedure (Cont'd)

3	CHECK DTC	
Perform Diagnostic Trouble Code (DTC) confirmation procedure. Refer to "DIAGNOSTIC TROUBLE CODE (DTC) CONFIRMATION PROCEDURE", AT-117.		
OK or NG		
OK	▶	INSPECTION END
NG	▶	<ol style="list-style-type: none"> 1. Perform TCM input/output signal inspection. 2. If NG, recheck TCM pin terminals for damage or loose connection with harness connector.

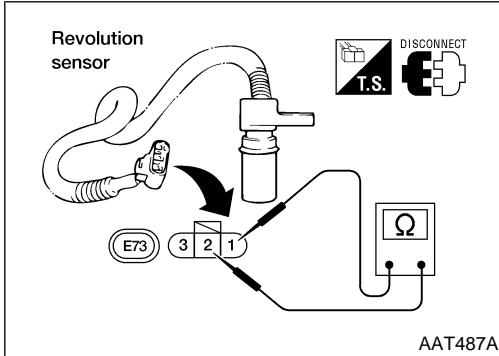

Component Inspection REVOLUTION SENSOR

NGAT0036

NGAT0036S01

- For removal, refer to "Revolution Sensor Replacement", AT-268.
- Check resistance between terminals 1 and 2.

Terminal No.		Resistance
1	2	500 - 650Ω

DTC P0725 ENGINE SPEED SIGNAL

Description

Description

The engine speed signal is sent from the ECM to the TCM. NGAT0037

TCM TERMINALS AND REFERENCE VALUE

NGAT0037S02

Remarks: Specification data are reference values.

Terminal No.	Wire color	Item	Condition	Judgement standard (Approx.)
39	P/L	Engine speed signal	 When engine runs at idle speed.	0.5 - 2.5V

ON BOARD DIAGNOSIS LOGIC

NGAT0037S03

Diagnostic trouble code	Malfunction is detected when ...	Check item (Possible cause)
(P) : ENGINE SPEED SIG (GST) : P0725	TCM does not receive the proper voltage signal from ECM.	<ul style="list-style-type: none"> Harness or connectors (The sensor circuit is open or shorted.)

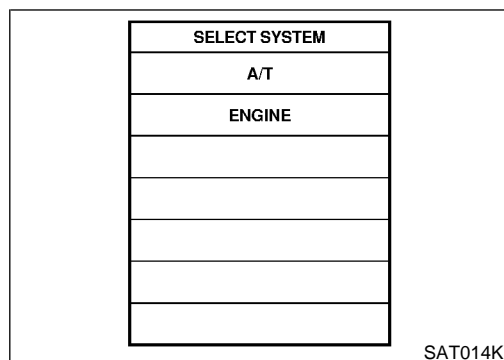

DIAGNOSTIC TROUBLE CODE (DTC) CONFIRMATION PROCEDURE

NGAT0037S01

CAUTION:

Always drive vehicle at a safe speed.

NOTE:

If "DIAGNOSTIC TROUBLE CODE CONFIRMATION PROCEDURE" has been previously conducted, always turn ignition switch OFF and wait at least 5 seconds before conducting the next test.

After the repair, perform the following procedure to confirm the malfunction is eliminated.

(P) With CONSULT-II

- Turn ignition switch ON and select "DATA MONITOR" mode for "ENGINE" with CONSULT-II.
- Start engine and maintain the following conditions for at least 10 consecutive seconds.

VHCL SPEED SE: 10 km/h (6 MPH) or more

THRTL POS SEN: More than 1.2V

Selector lever: D position (O/D ON)

(GST) With GST

Follow the procedure "With CONSULT-II".

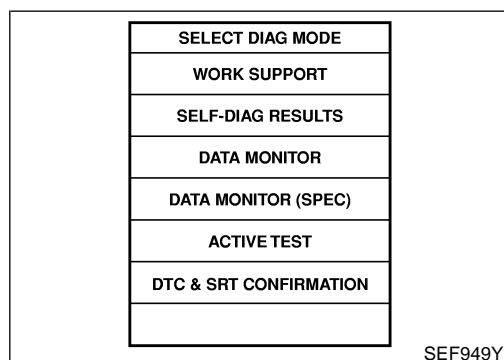

DTC P0725 ENGINE SPEED SIGNAL

Wiring Diagram — AT — ENGSS

Wiring Diagram — AT — ENGSS

NGAT0189

AT-ENGSS-01

: Detectable line for DTC
 : Non-detectable line for DTC

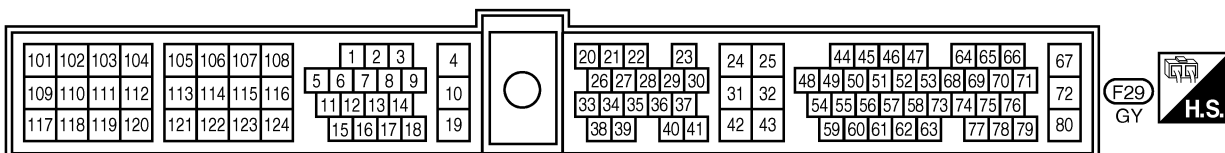
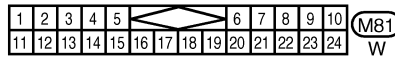
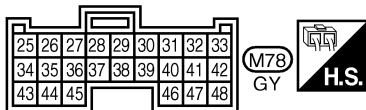
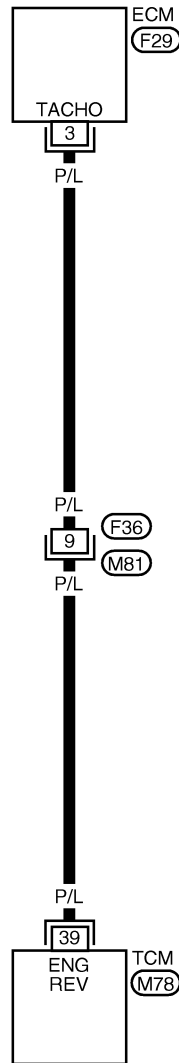

AAT585A

DTC P0725 ENGINE SPEED SIGNAL

Diagnostic Procedure

Diagnostic Procedure

NGAT0038

1	CHECK DTC WITH ECM	
Perform diagnostic test mode II (self-diagnostic results) for engine control. Check ignition signal circuit condition.		
OK or NG		
OK	▶	GO TO 2.
NG	▶	Check ignition signal circuit for engine control. Refer to EC-1138 (VG33E only) or EC-1718 (VG33ER only), "IGNITION SIGNAL".

2	CHECK INPUT SIGNAL															
<p> With CONSULT-II</p> <ol style="list-style-type: none"> Start engine. Select "TCM INPUT SIGNALS" in "DATA MONITOR" mode for "A/T" with CONSULT-II. Read out the value of "ENGINE SPEED". Check engine speed changes according to throttle position. 																
<table border="1"> <thead> <tr> <th colspan="2">DATA MONITOR</th> </tr> <tr> <th>MONITORING</th> <th></th> </tr> </thead> <tbody> <tr> <td>ENGINE SPEED</td> <td>XXX rpm</td> </tr> <tr> <td>TURBINE REV</td> <td>XXX rpm</td> </tr> <tr> <td>OVERDRIVE SW</td> <td>ON</td> </tr> <tr> <td>PN POSI SW</td> <td>OFF</td> </tr> <tr> <td>R POSITION SW</td> <td>OFF</td> </tr> </tbody> </table>			DATA MONITOR		MONITORING		ENGINE SPEED	XXX rpm	TURBINE REV	XXX rpm	OVERDRIVE SW	ON	PN POSI SW	OFF	R POSITION SW	OFF
DATA MONITOR																
MONITORING																
ENGINE SPEED	XXX rpm															
TURBINE REV	XXX rpm															
OVERDRIVE SW	ON															
PN POSI SW	OFF															
R POSITION SW	OFF															
SAT645J																

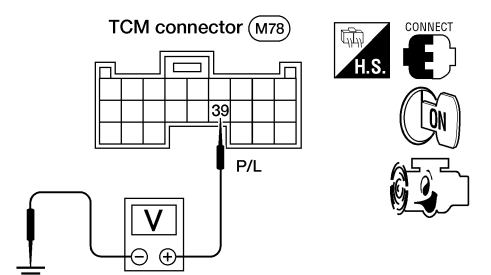
<p> Without CONSULT-II</p> <ol style="list-style-type: none"> Start engine. Check voltage between TCM harness connector M78 terminal 39 and ground. 		
		
AAT488A		
Does battery voltage (idle speed) 0.5 - 2.5V?		
Yes	▶	GO TO 3.
No	▶	<p>Check the following items:</p> <ul style="list-style-type: none"> ● Harness for short or open between TCM and ECM ● Resistor ● Ignition coil <p>Refer to EC-1138 (VG33E only) or EC-1718 (VG33ER only), "IGNITION SIGNAL".</p>

GI
MA
EM
LC
EC
FE
CL
MT
AT
TF
PD
AX
SU
BR
ST
RS
BT
HA
SC
EL
IDX

DTC P0725 ENGINE SPEED SIGNAL

Diagnostic Procedure (Cont'd)

3	CHECK DTC
Perform Diagnostic Trouble Code (DTC) confirmation procedure. Refer to "DIAGNOSTIC TROUBLE CODE (DTC) CONFIRMATION PROCEDURE", AT-121.	
OK or NG	
OK	▶ INSPECTION END
NG	▶ 1. Perform TCM input/output signal inspection. 2. If NG, recheck TCM pin terminals for damage or loose connection with harness connector.

DTC P0731 IMPROPER SHIFTING TO 1ST GEAR POSITION

Description

Description

- This is an OBD-II self-diagnostic item and not available in TCM self-diagnosis. NGAT0039
- This malfunction will not be detected while the O/D OFF indicator lamp is indicating another self-diagnosis malfunction.
- This malfunction is detected when the A/T does not shift into first gear position as instructed by the TCM. This is not caused by electrical malfunction (circuits open or shorted) but by mechanical malfunction such as control valve sticking, improper solenoid valve operation, etc.

Gear position	1	2	3	4
Shift solenoid valve A	ON (Closed)	OFF (Open)	OFF (Open)	ON (Closed)
Shift solenoid valve B	ON (Closed)	ON (Closed)	OFF (Open)	OFF (Open)

TCM TERMINALS AND REFERENCE VALUE

NGAT0039S02

Remarks: Specification data are reference values.

Terminal No.	Wire color	Item	Condition	Judgement standard (Approx.)
11	LW	Shift solenoid valve A	When shift solenoid valve A operates. (When driving in D ₁ or D ₄ .)	Battery voltage
			When shift solenoid valve A does not operate. (When driving in D ₂ or D ₃ .)	0V
12	LY	Shift solenoid valve B	When shift solenoid valve B operates. (When driving in D ₁ or D ₂ .)	Battery voltage
			When shift solenoid valve B does not operate. (When driving in D ₃ or D ₄ .)	0V



ON BOARD DIAGNOSIS LOGIC

NGAT0039S03

This diagnosis monitors actual gear position by checking the torque converter slip ratio calculated by TCM as follows:

$$\text{Torque converter slip ratio} = A \times C/B$$

A: Output shaft revolution signal from revolution sensor

B: Engine speed signal from ECM

C: Gear ratio determined as gear position which TCM supposes
If the actual gear position is higher than the position (1st) supposed by TCM, the slip ratio will be more than normal. In case the ratio exceeds the specified value, TCM judges this diagnosis malfunction.

This malfunction will be caused when either shift solenoid valve A is stuck open or shift solenoid valve B is stuck open.

Gear position supposed by TCM	1	2	3	4
In case of gear position with no malfunctions	1	2	3	4
In case of gear position with shift solenoid valve A stuck open	2*	2	3	3
In case of gear position with shift solenoid valve B stuck open	4*	3	3	4

*: P0731 is detected.

DTC P0731 IMPROPER SHIFTING TO 1ST GEAR POSITION

Description (Cont'd)

Diagnostic trouble code	Malfunction is detected when ...	Check item (Possible cause)
: A/T 1ST GR FNCTN : P0731	A/T cannot be shifted to the 1st gear position even if electrical circuit is good.	<ul style="list-style-type: none"> ● Shift solenoid valve A ● Shift solenoid valve B ● Each clutch ● Hydraulic control circuit

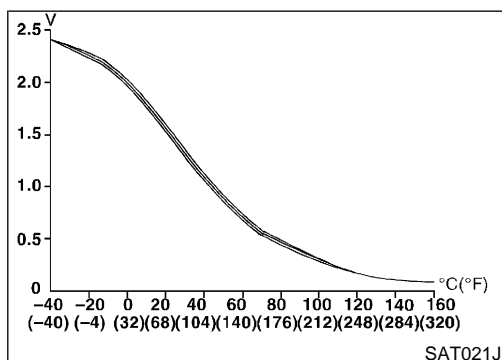
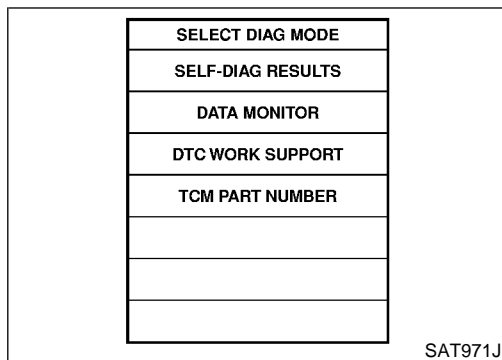
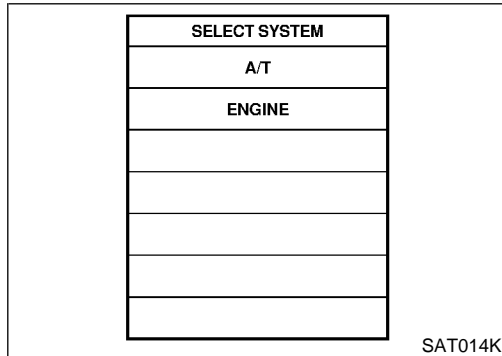

DIAGNOSTIC TROUBLE CODE (DTC) CONFIRMATION PROCEDURE

NGAT0039S01

CAUTION:

- Always drive vehicle at a safe speed.
- Be careful not to rev engine into the red zone on the tachometer.

NOTE:

If "DIAGNOSTIC TROUBLE CODE CONFIRMATION PROCEDURE" has been previously conducted, always turn ignition switch OFF and wait at least 5 seconds before conducting the next test.

TESTING CONDITIONS:

Always drive vehicle on a level road to improve the accuracy of test.

After the repair, perform the following procedure to confirm the malfunction is eliminated.

With CONSULT-II

- 1) Start engine and select "DATA MONITOR" mode for "A/T" with CONSULT-II.
- 2) Make sure that output voltage of A/T fluid temperature sensor is within the range below.

FLUID TEMP SEN: 0.4 - 1.5V

If out of range, drive the vehicle to decrease the voltage (warm up the fluid) or stop engine to increase the voltage (cool down the fluid).

- 3) Select "1ST GR FNCTN P0731" of "DTC WORK SUPPORT" mode for "A/T" with CONSULT-II and touch "START".
- 4) Accelerate vehicle to 17 to 23 km/h (11 to 14 MPH) under the following condition and release the accelerator pedal completely.

THROTTLE POSI: Less than 1/8 (at all times during step 4)
Selector lever: D position (O/D ON)

- Check that "GEAR" shows 2 after releasing pedal.
- 5) Depress accelerator pedal to WOT (more than 7/8 of "THROTTLE POSI") quickly from a speed of 17 to 23 km/h (11 to 14 MPH) until "TESTING" changes to "STOP VEHICLE" or "COMPLETED". (It will take approximately 3 seconds.)
 If the check result NG appears on CONSULT-II screen, go to "DIAGNOSTIC PROCEDURE", AT-129.
 If "STOP VEHICLE" appears on CONSULT-II screen, go to the following step.

- Check that "GEAR" shows 1 when depressing accelerator pedal to WOT.
- If "TESTING" does not appear on CONSULT-II for a long time, select "SELF-DIAG RESULTS" for "ENGINE". In case

DTC P0731 IMPROPER SHIFTING TO 1ST GEAR POSITION

Description (Cont'd)

a 1st trip DTC other than P0731 is shown, refer to applicable "TROUBLE DIAGNOSIS FOR DTC".

- 6) Stop vehicle.
- 7) Follow the instruction displayed. (Check for normal shifting referring to the table below.)

Vehicle condition	Gear on actual transmission shift pattern when screen is changed to 1 → 2 → 3 → 4
No malfunction exists	1 → 2 → 3 → 4
Malfunction for P0731 exists.	2 → 2 → 3 → 3
	4 → 3 → 3 → 4

- 8) Make sure that "OK" is displayed. (If "NG" is displayed, refer to "DIAGNOSTIC PROCEDURE".)
Refer to "DIAGNOSTIC PROCEDURE", AT-129.
Refer to "Shift Schedule", AT-348.

 **With GST**

Follow the procedure "With CONSULT-II".

GI

MA

EM

LC

EC

FE

CL

MT

AT

TF

PD

AX

SU

BR

ST

RS

BT

HA

SC

EL

IDX

DTC P0731 IMPROPER SHIFTING TO 1ST GEAR POSITION

Wiring Diagram — AT — 1ST

Wiring Diagram — AT — 1ST

NGAT0190

AT-1STSIG-01

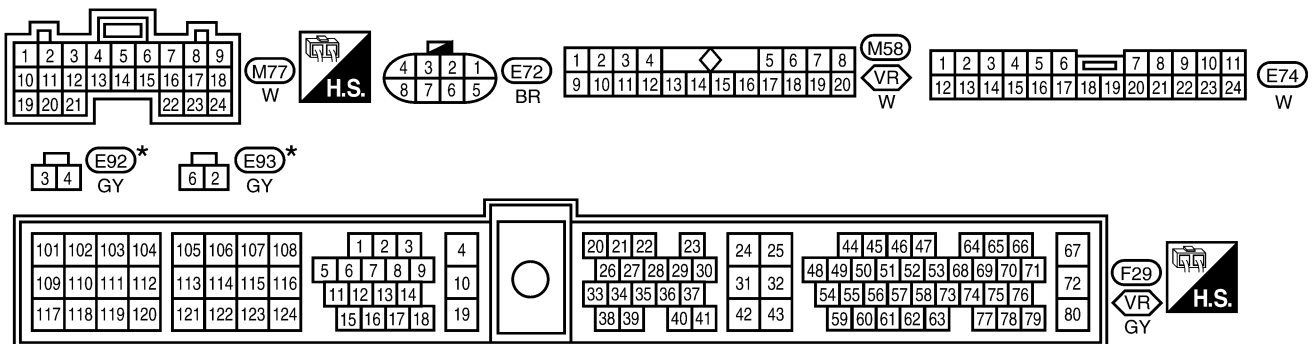
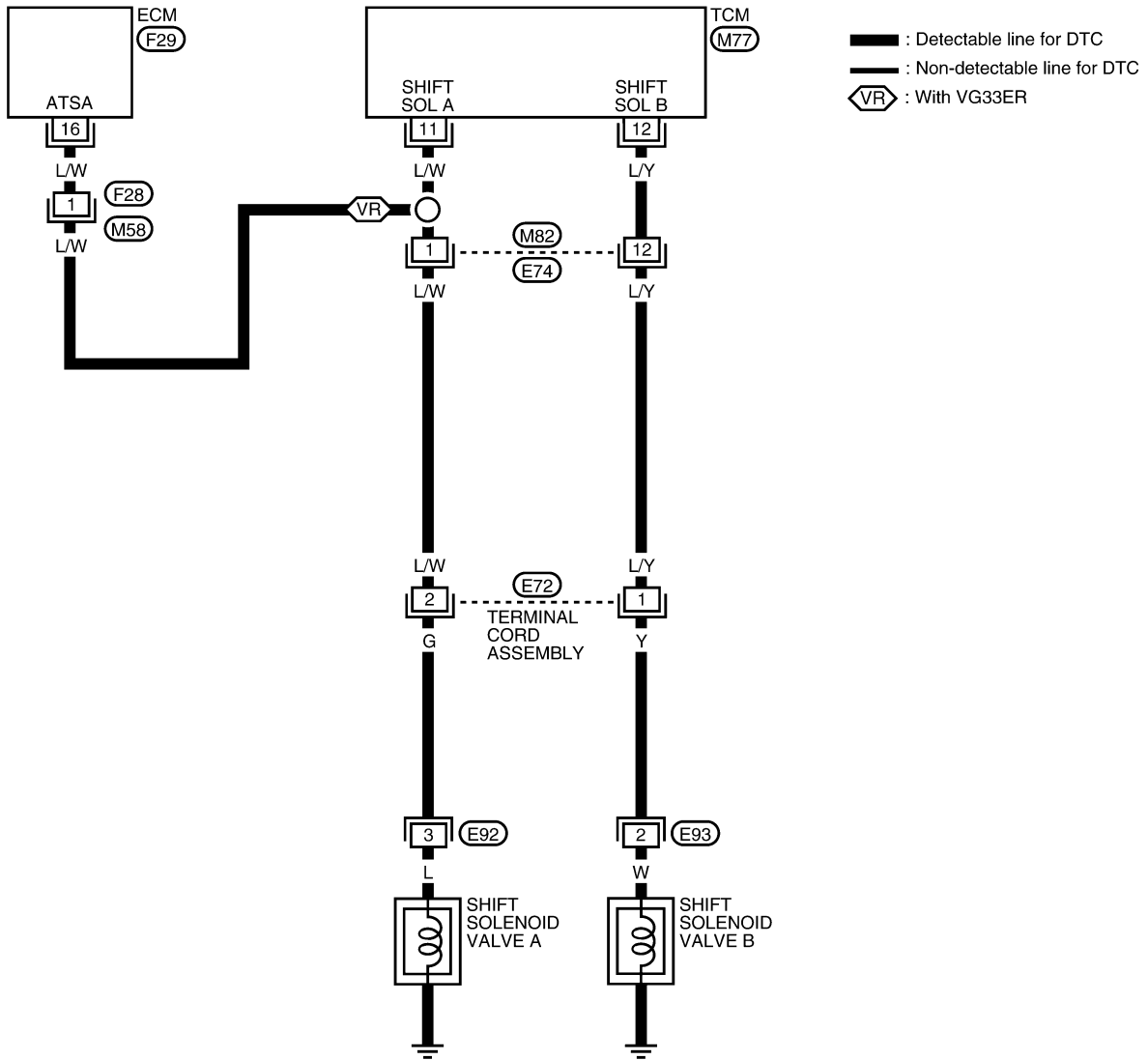

*: This connector is not shown in "HARNESS LAYOUT" of EL section.

WAT473

DTC P0731 IMPROPER SHIFTING TO 1ST GEAR POSITION

Diagnostic Procedure

Diagnostic Procedure

NGAT0040

1	CHECK SHIFT SOLENOID VALVE	
<p>1. Remove control valve assembly. Refer to "REMOVAL", AT-267. 2. Check shift solenoid valve operation.</p> <ul style="list-style-type: none"> ● Shift solenoid valve A ● Shift solenoid valve B <p>Refer to "Component Inspection", AT-130.</p> <p style="text-align: center;">OK or NG</p>		
OK	▶	GO TO 2.
NG	▶	Repair or replace shift solenoid valve assembly.

GI
MA
EM
LC

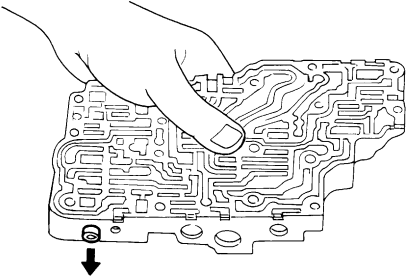
2	CHECK CONTROL VALVE	
<p>1. Disassemble control valve assembly. Refer to "Control Valve Assembly", AT-293. 2. Check to ensure that:</p> <ul style="list-style-type: none"> ● Valve, sleeve and plug slide along valve bore under their own weight. ● Valve, sleeve and plug are free from burrs, dents and scratches. ● Control valve springs are free from damage, deformation and fatigue. ● Hydraulic line is free from obstacles. <div style="text-align: center;">  </div> <p style="text-align: right;">SAT367H</p> <p style="text-align: center;">OK or NG</p>		
OK	▶	GO TO 3.
NG	▶	Repair control valve assembly.

EC
FE
CL
MT

AT

TF
PD
AX

3	CHECK DTC	
<p>Perform Diagnostic Trouble Code (DTC) confirmation procedure. Refer to "DIAGNOSTIC TROUBLE CODE (DTC) CONFIRMATION PROCEDURE", AT-126.</p> <p style="text-align: center;">OK or NG</p>		
OK	▶	INSPECTION END
NG	▶	Check control valve again. Repair or replace control valve assembly.

BR
ST

RS

BT

HA

SC

EL

IDX

DTC P0731 IMPROPER SHIFTING TO 1ST GEAR POSITION

Component Inspection

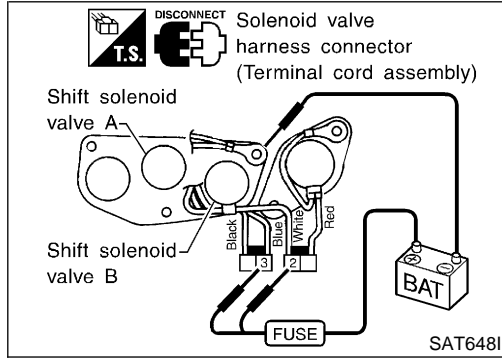
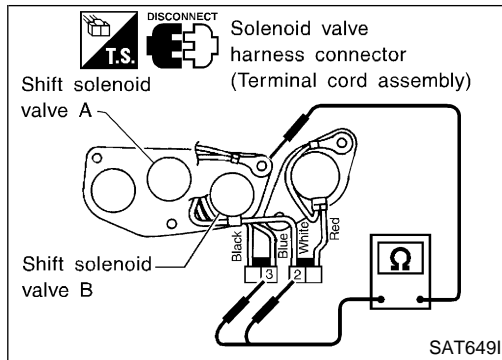

Component Inspection

SHIFT SOLENOID VALVE A AND B

=NGAT0041

NGAT0041S01

- For removal, refer to "REMOVAL", AT-267.

Resistance Check

NGAT0041S0101

- Check resistance between terminals (3 or 2) and ground.

Solenoid valve	Terminal No.	Resistance (Approx.)
Shift solenoid valve A	3	20 - 40Ω
Shift solenoid valve B	2	

Operation Check

NGAT0041S0102

- Check solenoid valve by listening for its operating sound while applying battery voltage to the terminals (3 or 2) and ground.

DTC P0732 IMPROPER SHIFTING TO 2ND GEAR POSITION

Description

Description

- This is an OBD-II self-diagnostic item and not available in TCM self-diagnosis. NGAT0042
- This malfunction will not be detected while the O/D OFF indicator lamp is indicating another self-diagnosis malfunction.
- This malfunction is detected when the A/T does not shift into second gear position as instructed by the TCM. This is not caused by electrical malfunction (circuits open or shorted) but by mechanical malfunction such as control valve sticking, improper solenoid valve operation, etc.

Gear position	1	2	3	4
Shift solenoid valve A	ON (Closed)	OFF (Open)	OFF (Open)	ON (Closed)
Shift solenoid valve B	ON (Closed)	ON (Closed)	OFF (Open)	OFF (Open)

TCM TERMINALS AND REFERENCE VALUE

NGAT0042S02

Remarks: Specification data are reference values.

Terminal No.	Wire color	Item	Condition	Judgement standard (Approx.)	
12	L/Y	Shift solenoid valve B		When shift solenoid valve B operates. (When driving in "D ₁ " or "D ₂ ".)	Battery voltage
				When shift solenoid valve B does not operate. (When driving in "D ₃ " or "D ₄ ".)	0V

ON BOARD DIAGNOSIS LOGIC

NGAT0042S03

This diagnosis monitors actual gear position by checking the torque converter slip ratio calculated by TCM as follows:

Torque converter slip ratio = A x C/B

A: Output shaft revolution signal from revolution sensor



B: Engine speed signal from ECM

C: Gear ratio determined as gear position which TCM supposes
 If the actual gear position is higher than the position (2nd) supposed by TCM, the slip ratio will be more than normal. In case the ratio exceeds the specified value, TCM judges this diagnosis malfunction.

This malfunction will be caused when shift solenoid valve B is stuck open.

Gear position supposed by TCM	1	2	3	4
In case of gear position with no malfunctions	1	2	3	4
In case of gear position with shift solenoid valve B stuck open	4	3*	3	4

*: P0732 is detected.

Diagnostic trouble code	Malfunction is detected when ...	Check item (Possible cause)
 : A/T 2ND SIGNAL  : P0732	A/T cannot be shifted to the 2nd gear position even if electrical circuit is good.	A/T cannot be shifted to the 2nd gear position even if electrical circuit is good.

DTC P0732 IMPROPER SHIFTING TO 2ND GEAR POSITION

Description (Cont'd)

SELECT SYSTEM
A/T
ENGINE

SAT014K

SELECT DIAG MODE
SELF-DIAG RESULTS
DATA MONITOR
DTC WORK SUPPORT
TCM PART NUMBER

SAT971J

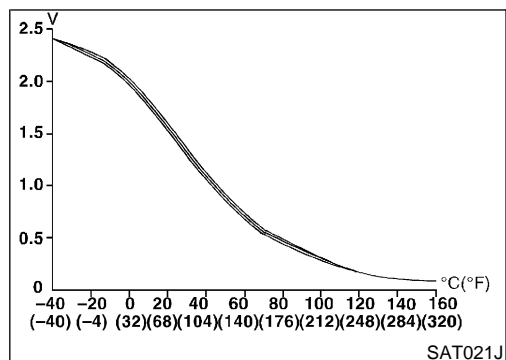

DIAGNOSTIC TROUBLE CODE (DTC) CONFIRMATION PROCEDURE

NGAT0042S01

CAUTION:

- Always drive vehicle at a safe speed.
- Be careful not to rev engine into the red zone on the tachometer.

NOTE:

If "DIAGNOSTIC TROUBLE CODE CONFIRMATION PROCEDURE" has been previously conducted, always turn ignition switch OFF and wait at least 5 seconds before conducting the next test.

TESTING CONDITIONS:

Always drive vehicle on a level road to improve the accuracy of test.

After the repair, perform the following procedure to confirm the malfunction is eliminated.

With CONSULT

- 1) Start engine and select "DATA MONITOR" mode for "A/T" with CONSULT.
- 2) Make sure that output voltage of A/T fluid temperature sensor is within the range below.

FLUID TEMP SEN: 0.4 - 1.5V

If out of range, drive the vehicle to decrease the voltage (warm up the fluid) or stop engine to increase the voltage (cool down the fluid).

- 3) Select "2ND GR FNCTN P0732" of "DTC WORK SUPPORT" mode for "A/T" with CONSULT-II and touch "START".
- 4) Accelerate vehicle to 50 to 55 km/h (31 to 34 MPH) under the following condition and release the accelerator pedal completely.

**THROTTLE POSI: Less than 1/8 (at all times during step 4)
Selector lever: D position (O/D ON)**

- Check that "GEAR" shows 3 or 4 after releasing pedal.
- 5) Depress accelerator pedal to WOT (more than 7/8 of "THROTTLE POSI") quickly from a speed of 50 to 55 km/h (31 to 34 MPH) until "TESTING" changes to "STOP VEHICLE" or "COMPLETED". (It will take approximately 3 seconds.)
If the check result NG appears on CONSULT-II screen, go to "Diagnostic Procedure", AT-135.
If "STOP VEHICLE" appears on CONSULT-II screen, go to following step.
 - Check that "GEAR" shows 2 when depressing accelerator pedal to WOT.
 - If "TESTING" does not appear on CONSULT-II for a long time, select "SELF-DIAG RESULTS" for "ENGINE". In case a 1st trip DTC other than P0732 is shown, refer to applicable "TROUBLE DIAGNOSIS FOR DTC".
 - 6) Stop vehicle.
 - 7) Follow the instruction displayed. (Check for normal shifting referring to the table below.)

Vehicle condition	Gear on actual transmission shift pattern when screen is changed to 1 → 2 → 3 → 4
No malfunction exists	1 → 2 → 3 → 4
Malfunction for P0732 exists.	4 → 3 → 3 → 4

- 8) Make sure that "OK" is displayed. (If "NG" is displayed, refer

DTC P0732 IMPROPER SHIFTING TO 2ND GEAR POSITION

Description (Cont'd)

to "DIAGNOSTIC PROCEDURE".) Refer to "Diagnostic Procedure", AT-135. Refer to shift schedule, AT-348.



With GST

Follow the procedure "With CONSULT-II".

GI

MA

EM

LC

EC

FE

CL

MT

AT

TF

PD

AX

SU

BR

ST

RS

BT

HA

SC

EL

IDX

DTC P0732 IMPROPER SHIFTING TO 2ND GEAR POSITION

Wiring Diagram — AT — 2ND

Wiring Diagram — AT — 2ND

NGAT0191

AT-2NDSIG-01

: Detectable line for DTC
 : Non-detectable line for DTC

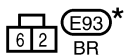
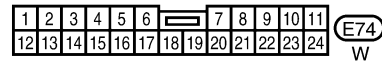
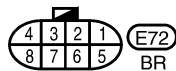
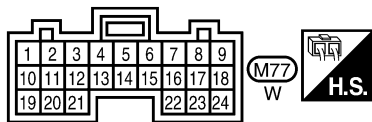
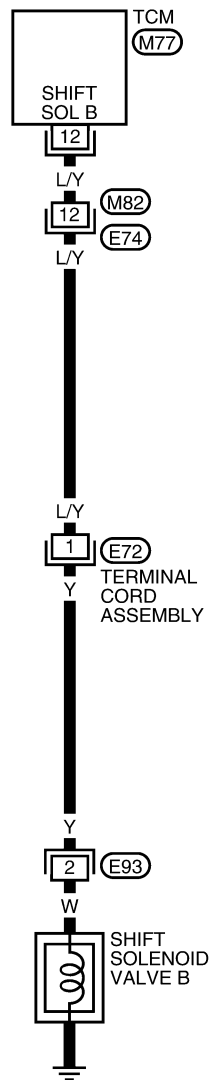

*: This connector is not shown in "HARNESS LAYOUT" of EL section.

LAT503

DTC P0732 IMPROPER SHIFTING TO 2ND GEAR POSITION

Diagnostic Procedure

Diagnostic Procedure

NGAT0043

1	CHECK SHIFT SOLENOID VALVE		
1. Remove control valve assembly. Refer to "REMOVAL", AT-267. 2. Check shift solenoid valve operation. <ul style="list-style-type: none"> ● Shift solenoid valve B Refer to "Component Inspection", AT-135.			
OK or NG			
OK	▶	GO TO 2.	
NG	▶	Repair or replace shift solenoid valve assembly.	

GI
MA
EM
LC

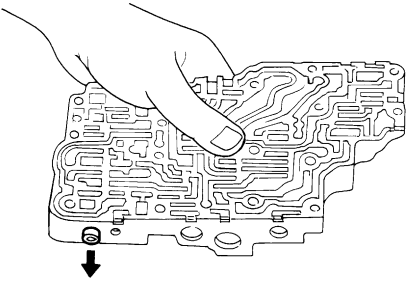
2	CHECK CONTROL VALVE		
1. Disassemble control valve assembly. Refer to "Control Valve Assembly", AT-293. 2. Check to ensure that: <ul style="list-style-type: none"> ● Valve, sleeve and plug slide along valve bore under their own weight. ● Valve, sleeve and plug are free from burrs, dents and scratches. ● Control valve springs are free from damage, deformation and fatigue. ● Hydraulic line is free from obstacles. 			
			
SAT367H			
OK or NG			
OK	▶	GO TO 3.	
NG	▶	Repair control valve assembly.	

EC
FE
CL
MT

AT

TF

PD

AX

SU

3	CHECK DTC		
Perform Diagnostic Trouble Code (DTC) confirmation procedure. Refer to "DIAGNOSTIC TROUBLE CODE (DTC) CONFIRMATION PROCEDURE", AT-132.			
OK or NG			
OK	▶	INSPECTION END	
NG	▶	Check control valve again. Repair or replace control valve assembly.	

BR

ST

RS

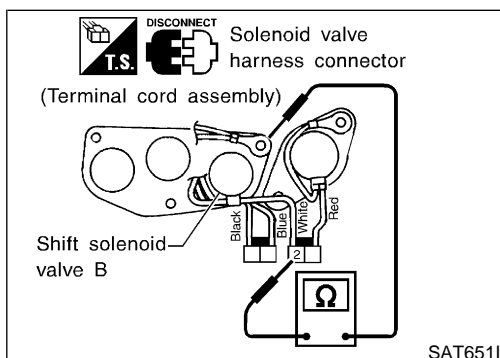

Component Inspection SHIFT SOLENOID VALVE B

NGAT0044

NGAT0044S01

- For removal, refer to "REMOVAL", AT-267.

Resistance Check

NGAT0044S0101

- Check resistance between terminal 2 and ground.

Solenoid valve	Terminal No.		Resistance (Approx.)
Shift solenoid valve B	2	Ground	20 - 40Ω

BT

HA

SC

EL

IDX

DTC P0732 IMPROPER SHIFTING TO 2ND GEAR POSITION

Component Inspection (Cont'd)

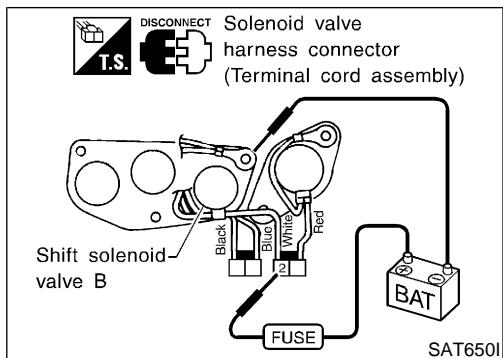

Operation Check

- Check solenoid valve by listening for its operating sound while applying battery voltage to the terminal 2 and ground. NGAT0044SD102

DTC P0733 IMPROPER SHIFTING TO 3RD GEAR POSITION

Description

Description

- This is an OBD-II self-diagnostic item and not available in TCM self-diagnosis. NGAT0045
- This malfunction will not be detected while the O/D OFF indicator lamp is indicating another self-diagnosis malfunction.
- This malfunction is detected when the A/T does not shift into third gear position as instructed by the TCM. This is not caused by electrical malfunction (circuits open or shorted) but by mechanical malfunction such as control valve sticking, improper solenoid valve operation, malfunctioning servo piston or brake band, etc.

Gear position	1	2	3	4
Shift solenoid valve A	ON (Closed)	OFF (Open)	OFF (Open)	ON (Closed)
Shift solenoid valve B	ON (Closed)	ON (Closed)	OFF (Open)	OFF (Open)

TCM TERMINALS AND REFERENCE VALUE

NGAT0045S02

Remarks: Specification data are reference values.

Terminal No.	Wire color	Item	Condition	Judgement standard (Approx.)
11	L/W	Shift solenoid valve A	 When shift solenoid valve A operates. (When driving in D ₁ or D ₄ .)	Battery voltage
			When shift solenoid valve A does not operate. (When driving in D ₂ or D ₃ .)	0V

ON BOARD DIAGNOSIS LOGIC

NGAT0045S03

This diagnosis monitors actual gear position by checking the torque converter slip ratio calculated by TCM as follows:

Torque converter slip ratio = A x C/B

A: Output shaft revolution signal from revolution sensor



B: Engine speed signal from ECM

C: Gear ratio determined as gear position which TCM supposes
If the actual gear position is higher than the position (3rd) supposed by TCM, the slip ratio will be more than normal. In case the ratio exceeds the specified value, TCM judges this diagnosis malfunction.

This malfunction will be caused when shift solenoid valve A is stuck closed.

Gear position supposed by TCM	1	2	3	4
In case of gear position with no malfunctions	1	2	3	4
In case of gear position with shift solenoid valve A stuck closed	1	1	4*	4

*: P0733 is detected.

Diagnostic trouble code	Malfunction is detected when ...	Check item (Possible cause)
 : A/T 3RD GR FNCTN	A/T cannot be shifted to the 3rd gear position even if electrical circuit is good.	<ul style="list-style-type: none"> ● Shift solenoid valve A ● Each clutch ● Hydraulic control circuit
 : P0733		

DTC P0733 IMPROPER SHIFTING TO 3RD GEAR POSITION

Description (Cont'd)

SELECT SYSTEM
A/T
ENGINE

SAT014K

SELECT DIAG MODE
SELF-DIAG RESULTS
DATA MONITOR
DTC WORK SUPPORT
TCM PART NUMBER

SAT971J

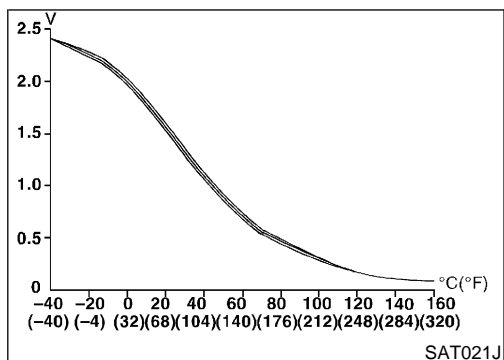

DIAGNOSTIC TROUBLE CODE (DTC) CONFIRMATION PROCEDURE

NGAT0045S01

CAUTION:

- Always drive vehicle at a safe speed.
- Be careful not to rev engine into the red zone on the tachometer.

NOTE:

If "DIAGNOSTIC TROUBLE CODE CONFIRMATION PROCEDURE" has been previously conducted, always turn ignition switch OFF and wait at least 5 seconds before conducting the next test.

TESTING CONDITIONS:

Always drive vehicle on a level road to improve the accuracy of test.

After the repair, perform the following procedure to confirm the malfunction is eliminated.

With CONSULT-II

- 1) Start engine and select "DATA MONITOR" mode for "A/T" with CONSULT-II.
- 2) Make sure that output voltage of A/T fluid temperature sensor is within the range below.

FLUID TEMP SEN: 0.4 - 1.5V

If out of range, drive the vehicle to decrease the voltage (warm up the fluid) or stop engine to increase the voltage (cool down the fluid).

- 3) Select "3RD GR FNCTN P0733" of "DTC WORK SUPPORT" mode for "A/T" with CONSULT-II and touch "START".
- 4) Accelerate vehicle to 70 to 85 km/h (43 to 53 MPH) under the following condition and release the accelerator pedal completely.

**THROTTLE POSI: Less than 1/8 (at all times during step 4)
Selector lever: D position (O/D ON)**

- Check that "GEAR" shows 4 after releasing pedal.
- 5) Depress accelerator pedal steadily with 3.5/8 - 4.5/8 of "THROTTLE POSI" from a speed of 70 to 85 km/h (43 to 53 MPH) until "TESTING" changes to "STOP VEHICLE" or "COMPLETED". (It will take approximately 3 seconds.)
If the check result NG appears on CONSULT-II screen, go to "Diagnostic Procedure", AT-141.
If "STOP VEHICLE" appears on CONSULT-II screen, go to following step.
 - Check that "GEAR" shows 3 when depressing accelerator pedal with 3.5/8 - 4.5/8 of "THROTTLE POSI".
 - If "TESTING" does not appear on CONSULT-II for a long time, select "SELF-DIAG RESULTS" for "ENGINE". In case a 1st trip DTC other than P0733 is shown, refer to applicable "TROUBLE DIAGNOSIS FOR DTC".
 - 6) Stop vehicle.
 - 7) Follow the instruction displayed. (Check for normal shifting referring to the table below.)

Vehicle condition	Gear on actual transmission shift pattern when screen is changed to 1 → 2 → 3 → 4
No malfunction exists.	1 → 2 → 3 → 4
Malfunction for P0733 exists.	1 → 1 → 4 → 4

- 8) Make sure that "OK" is displayed. (If "NG" is displayed, refer

DTC P0733 IMPROPER SHIFTING TO 3RD GEAR POSITION

Description (Cont'd)

to "Diagnostic Procedure".) Refer to "Diagnostic Procedure", AT-141.

Refer to "Shift Schedule", AT-348.

 **With GST**

Follow the procedure "With CONSULT-II".

GI

MA

EM

LC

EC

FE

CL

MT

AT

TF

PD

AX

SU

BR

ST

RS

BT

HA

SC

EL

IDX

DTC P0733 IMPROPER SHIFTING TO 3RD GEAR POSITION

Wiring Diagram — AT — 3RD

Wiring Diagram — AT — 3RD

NGAT0192

AT-3RDSIG-01

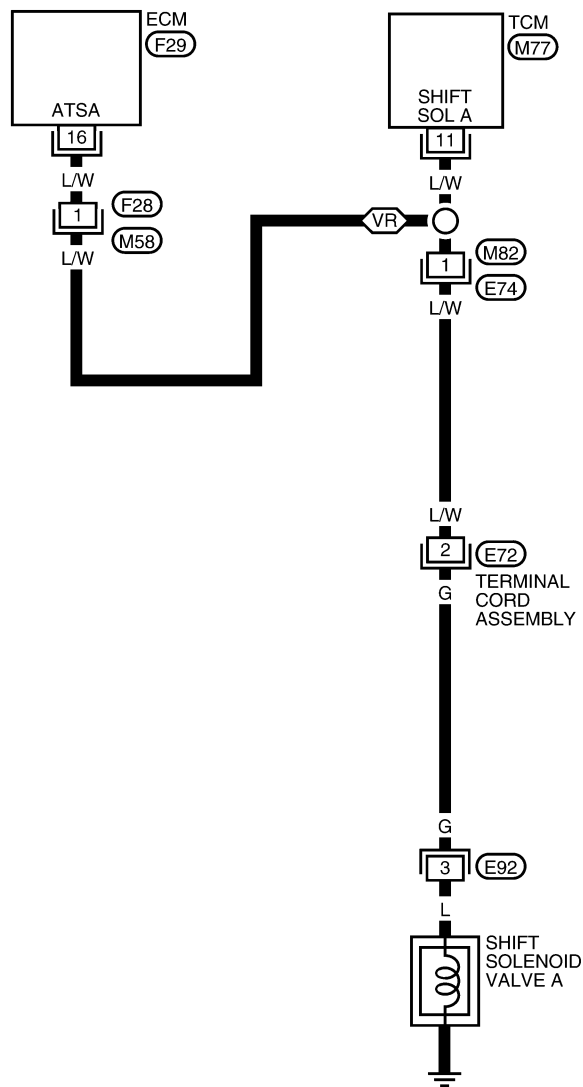

- : Detectable line for DTC
- : Non-detectable line for DTC
- VR : With VG33ER

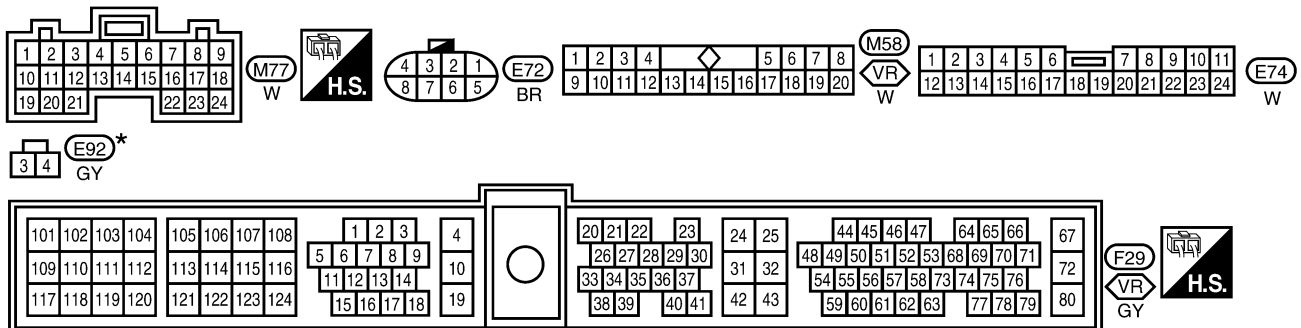

* : This connector is not shown in "HARNESS LAYOUT" of EL section.

WAT474

DTC P0733 IMPROPER SHIFTING TO 3RD GEAR POSITION

Diagnostic Procedure

Diagnostic Procedure

NGAT0046

1	CHECK SHIFT SOLENOID VALVE	
<p>1. Remove control valve assembly. Refer to "REMOVAL", AT-267. 2. Check shift solenoid valve operation.</p> <ul style="list-style-type: none"> ● Shift solenoid valve A <p>Refer to "Component Inspection", AT-142.</p> <p style="text-align: center;">OK or NG</p>		
OK	▶	GO TO 2.
NG	▶	Repair or replace shift solenoid valve assembly.

GI
MA
EM
LC

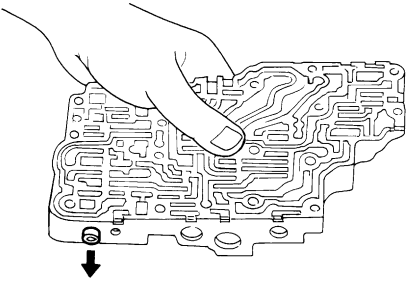
2	CHECK CONTROL VALVE	
<p>1. Disassemble control valve assembly. Refer to "Control Valve Assembly", AT-293. 2. Check to ensure that:</p> <ul style="list-style-type: none"> ● Valve, sleeve and plug slide along valve bore under their own weight. ● Valve, sleeve and plug are free from burrs, dents and scratches. ● Control valve springs are free from damage, deformation and fatigue. ● Hydraulic line is free from obstacles. <div style="text-align: center;">  </div> <p style="text-align: right;">SAT367H</p> <p style="text-align: center;">OK or NG</p>		
OK	▶	GO TO 3.
NG	▶	Repair control valve assembly.

EC
FE
CL
MT

AT

TF
PD

AX
SU

3	CHECK DTC	
<p>Perform Diagnostic Trouble Code (DTC) confirmation procedure. Refer to "DIAGNOSTIC TROUBLE CODE (DTC) CONFIRMATION PROCEDURE", AT-138.</p> <p style="text-align: center;">OK or NG</p>		
OK	▶	INSPECTION END
NG	▶	Check control valve again. Repair or replace control valve assembly.

BR
ST

RS
BT

HA
SC

EL
IDX

DTC P0733 IMPROPER SHIFTING TO 3RD GEAR POSITION

Component Inspection

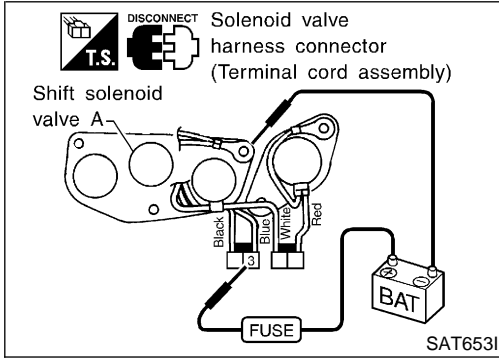
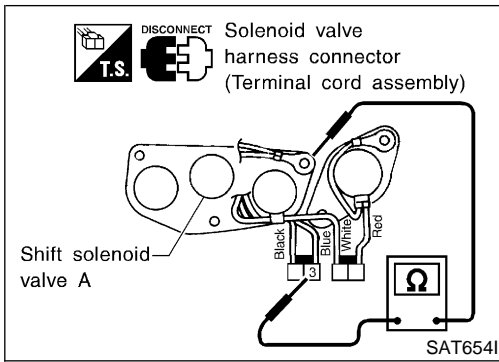

Component Inspection SHIFT SOLENOID VALVE A

=NGAT0047

NGAT0047S01

- For removal, refer to "REMOVAL", AT-267.

Resistance Check

NGAT0047S0101

- Check resistance between terminal 3 and ground.

Solenoid valve	Terminal No.		Resistance (Approx.)
Shift solenoid valve A	3	Ground	20 - 40Ω

Operation Check

NGAT0047S0102

- Check solenoid valve by listening for its operating sound while applying battery voltage to the terminal 3 and ground.

DTC P0734 IMPROPER SHIFTING TO 4TH GEAR POSITION

Description

Description

- This is an OBD-II self-diagnostic item and not available in TCM self-diagnosis. NGAT0048
- This malfunction will not be detected while the O/D OFF indicator lamp is indicating another self-diagnosis malfunction.
- This malfunction is detected when the A/T does not shift into fourth gear position or the torque converter clutch does not lock up as instructed by the TCM. This is not caused by electrical malfunction (circuits open or shorted) but by mechanical malfunction such as control valve sticking, improper solenoid valve operation, malfunctioning oil pump or torque converter clutch, etc.

CONSULT-II REFERENCE VALUE IN DATA MONITOR MODE

NGAT0048S04

Remarks: Specification data are reference values.



Monitor item	Condition	Specification (Approx.)
Torque converter clutch solenoid valve duty	Lock-up OFF	4%
	↓ Lock-up ON	↓ 94%
Line pressure solenoid valve duty	Small throttle opening (Low line pressure)	24%
	↓ Large throttle opening (High line pressure)	↓ 95%

Gear position	1	2	3	4
Shift solenoid valve A	ON (Closed)	OFF (Open)	OFF (Open)	ON (Closed)
Shift solenoid valve B	ON (Closed)	ON (Closed)	OFF (Open)	OFF (Open)

TCM TERMINALS AND REFERENCE VALUE

NGAT0048S02

Remarks: Specification data are reference values.

Terminal No.	Wire color	Item	Condition	Judgement standard (Approx.)	
1	GY/R	Line pressure solenoid valve		When releasing accelerator pedal after warming up engine.	1.5 - 2.5V
				When depressing accelerator pedal fully after warming up engine.	0V
2	BR/Y	Line pressure solenoid valve (with dropping resistor)		When releasing accelerator pedal after warming up engine.	5 - 14V
				When depressing accelerator pedal fully after warming up engine.	0V

DTC P0734 IMPROPER SHIFTING TO 4TH GEAR POSITION

Description (Cont'd)

Terminal No.	Wire color	Item	Condition		Judgement standard (Approx.)
11	L/W	Shift solenoid valve A		When shift solenoid valve A operates. (When driving in D ₁ or D ₄ .)	Battery voltage
				When shift solenoid valve A does not operate. (When driving in D ₂ or D ₃ .)	0V
12	L/Y	Shift solenoid valve B		When shift solenoid valve B operates. (When driving in D ₁ or D ₂ .)	Battery voltage
				When shift solenoid valve B does not operate. (When driving in D ₃ or D ₄ .)	0V

ON BOARD DIAGNOSIS LOGIC

NGAT004BS03

This diagnosis monitors actual gear position by checking the torque converter slip ratio calculated by TCM as follows:

Torque converter slip ratio = A x C/B

A: Output shaft revolution signal from revolution sensor

B: Engine speed signal from ECM



C: Gear ratio determined as gear position which TCM supposes

If the actual gear position is much lower than the position (4th) supposed by TCM, the slip ratio will be much less than normal. In case the ratio does not reach the specified value, TCM judges this diagnosis malfunction.

This malfunction will be caused when shift solenoid valve B is stuck closed.

Gear position supposed by TCM	1	2	3	4
In case of gear position with no malfunctions	1	2	3	4
In case of gear position with shift solenoid valve B stuck closed	1	2	2	1*

*: P0734 is detected.

Diagnostic trouble code	Malfunction is detected when ...	Check item (Possible cause)
 : A/T 4TH GR FNCTN  : P0734	A/T cannot be shifted to the 4th gear position even if electrical circuit is good.	<ul style="list-style-type: none"> ● Shift solenoid valve A ● Shift solenoid valve B ● Line pressure solenoid valve ● Each clutch ● Hydraulic control circuit

DTC P0734 IMPROPER SHIFTING TO 4TH GEAR POSITION

Description (Cont'd)

SELECT SYSTEM
A/T
ENGINE

SAT014K

SELECT DIAG MODE
SELF-DIAG RESULTS
DATA MONITOR
DTC WORK SUPPORT
TCM PART NUMBER

SAT971J

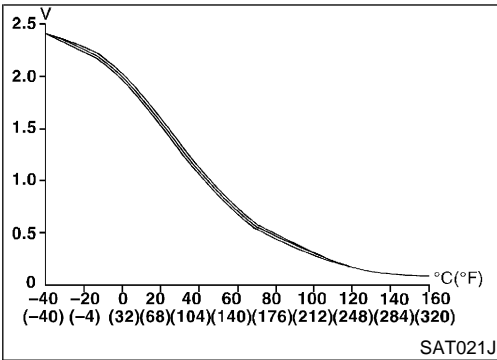

DIAGNOSTIC TROUBLE CODE (DTC) CONFIRMATION PROCEDURE

NGAT0048S01

CAUTION:

- Always drive vehicle at a safe speed.
- Be careful not to rev engine into the red zone on the tachometer.

NOTE:

If "DIAGNOSTIC TROUBLE CODE CONFIRMATION PROCEDURE" has been previously conducted, always turn ignition switch OFF and wait at least 5 seconds before conducting the next test.

TESTING CONDITIONS:

Always drive vehicle on a level road to improve the accuracy of test.

After the repair, perform the following procedure to confirm the malfunction is eliminated.

With CONSULT-II

- Start engine and select "DATA MONITOR" mode for "A/T" with CONSULT-II.
- Make sure that output voltage of A/T fluid temperature sensor is within the range below.

FLUID TEMP SEN: 0.4 - 1.5V

If out of range, drive the vehicle to decrease the voltage (warm up the fluid) or stop engine to increase the voltage (cool down the fluid).

- Select "4TH GR FNCTN P0734" of "DTC WORK SUPPORT" mode for "A/T" with CONSULT-II and touch "START".
- Accelerate vehicle to 50 to 60 km/h (31 to 37 MPH) under the following condition and release the accelerator pedal completely.

THROTTLE POSI: Less than 5.5/8 (at all times during step 4)

Selector lever: D position (O/D ON)

- Check that "GEAR" shows 3 after releasing pedal.
- Depress accelerator pedal steadily with 1/8 - 2/8 of "THROTTLE POSI" from a speed of 50 to 60 km/h (31 to 37 MPH) until "TESTING" has turned to "STOP VEHICLE" or "COMPLETED". (It will take approximately 3 seconds.)
If the check result NG appears on CONSULT-II screen, go to "Diagnostic Procedure", AT-148.
If "STOP VEHICLE" appears on CONSULT-II screen, go to following step.
 - Check that "GEAR" shows 4 when depressing accelerator pedal with 1/8 - 2/8 of "THROTTLE POSI".
 - If "TESTING" does not appear on CONSULT-II for a long time, select "SELF-DIAG RESULTS" for "ENGINE". In case a 1st trip DTC other than P0734 is shown, refer to applicable "TROUBLE DIAGNOSIS FOR DTC".
- Stop vehicle.
 - Follow the instruction displayed. (Check for normal shifting referring to the table below.)

Vehicle condition	Gear on actual transmission shift pattern when screen is changed to 1 → 2 → 3 → 4
No malfunction exists	1 → 2 → 3 → 4
Malfunction for P0734 exists.	1 → 2 → 2 → 1

GI
MA
EM
LC
EC
FE
CL
MT
AT
TF
PD
AX
SU
BR
ST
RS
BT
HA
SC
EL
IDX

DTC P0734 IMPROPER SHIFTING TO 4TH GEAR POSITION

Description (Cont'd)

- 8) Make sure that "OK" is displayed. If "NG" is displayed, refer to "Diagnostic Procedure", AT-148.
Refer to "Shift Schedule", AT-348.



With GST

Follow the procedure "With CONSULT-II".

DTC P0734 IMPROPER SHIFTING TO 4TH GEAR POSITION

Wiring Diagram — AT — 4TH

Wiring Diagram — AT — 4TH

NGAT0193

AT-4THSIG-01

— : Detectable line for DTC
 - - - : Non-detectable line for DTC

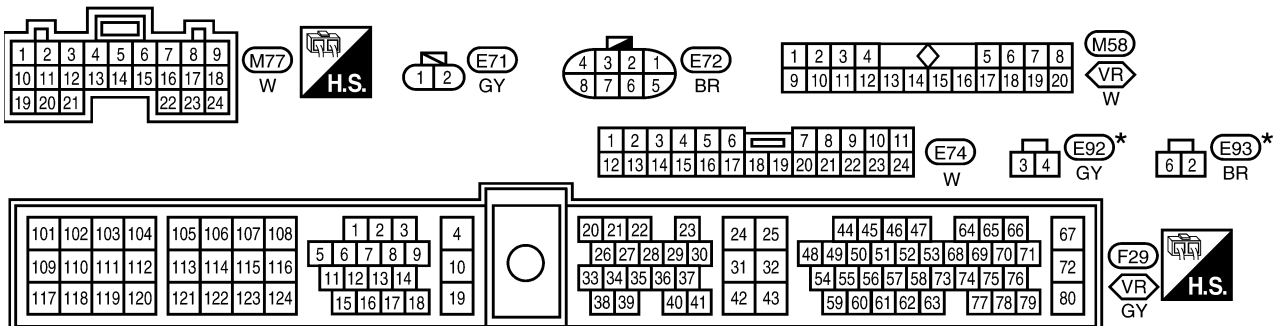
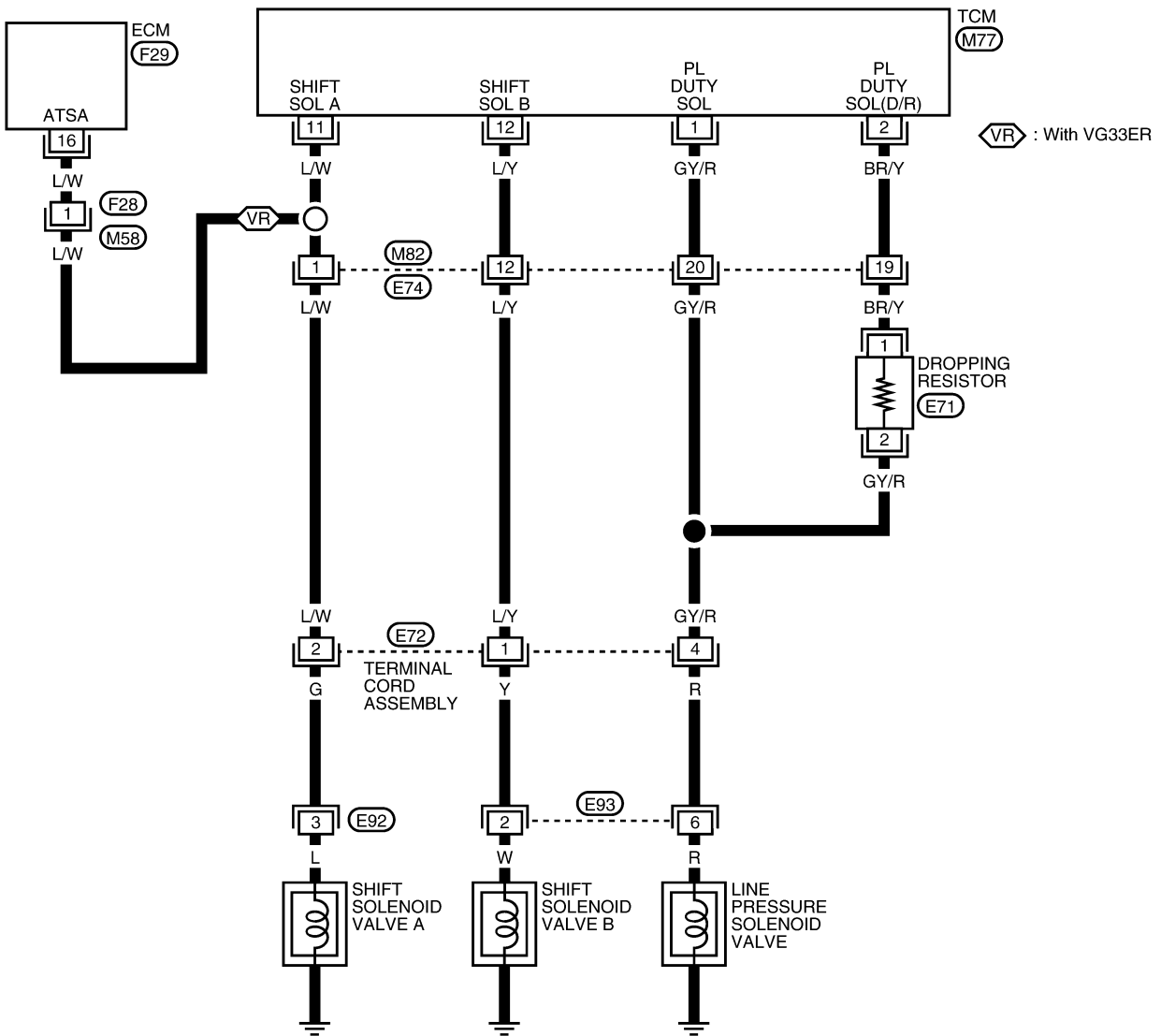

*: This connector is not shown in "HARNESS LAYOUT" of EL section.

WAT475

GI
 MA
 EM
 LC
 EC
 FE
 CL
 MT
AT
 TF
 PD
 AX
 SU
 BR
 ST
 RS
 BT
 HA
 SC
 EL
 IDX

DTC P0734 IMPROPER SHIFTING TO 4TH GEAR POSITION

Diagnostic Procedure

Diagnostic Procedure

NGAT0049

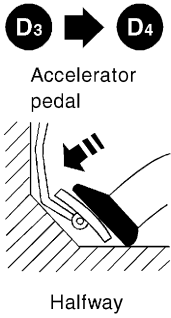
1	CHECK SHIFT UP (D₃ TO D₄)
Perform "Cruise test – Part 1", AT-74. Does A/T shift from D ₃ to D ₄ at the specified speed?	
 <p>Accelerator pedal</p> <p>Halfway</p>	
Yes or No	
Yes	▶ GO TO 9.
No	▶ GO TO 2.

SAT988H

2	CHECK LINE PRESSURE
Perform line pressure test. Refer to AT-65.	
OK or NG	
OK	▶ GO TO 3.
NG	▶ GO TO 7.

3	CHECK SOLENOID VALVES
1. Remove control valve assembly. Refer to "REMOVAL", AT-267. 2. Refer to "Component Inspection", AT-151.	
OK or NG	
OK	▶ GO TO 4.
NG	▶ Replace solenoid valve assembly.

DTC P0734 IMPROPER SHIFTING TO 4TH GEAR POSITION

Diagnostic Procedure (Cont'd)

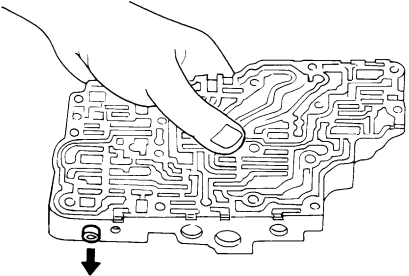
4	CHECK CONTROL VALVE	
<p>1. Disassemble control valve assembly. Refer to AT-293.</p> <p>2. Check to ensure that:</p> <ul style="list-style-type: none"> ● Valve, sleeve and plug slide along valve bore under their own weight. ● Valve, sleeve and plug are free from burrs, dents and scratches. ● Control valve springs are free from damage, deformation and fatigue. ● Hydraulic line is free from obstacles. 		
		
SAT367H		
OK or NG		
OK	▶	GO TO 5.
NG	▶	Repair control valve.

GI
MA
EM
LC
EC
FE
CL
MT

5	CHECK SHIFT UP (D₃ TO D₄)	
Does A/T shift from D ₃ to D ₄ at the specified speed?		
Yes or No		
Yes	▶	GO TO 9.
No	▶	Check control valve again. Repair or replace control valve assembly.

AT
TF
PD

6	CHECK LINE PRESSURE SOLENOID VALVE	
<p>1. Remove control valve assembly. Refer to AT-267.</p> <p>2. Refer to "Component Inspection", AT-151.</p>		
OK or NG		
OK	▶	GO TO 7.
NG	▶	Replace solenoid valve assembly.

AX
SU
BR
ST
RS
BT
HA
SC
EL
IDX

DTC P0734 IMPROPER SHIFTING TO 4TH GEAR POSITION

Diagnostic Procedure (Cont'd)

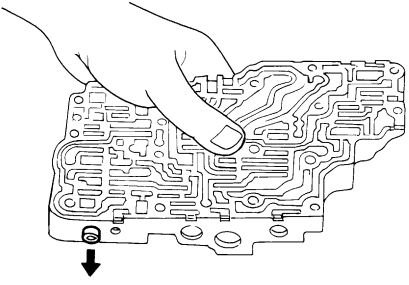
7	CHECK CONTROL VALVE
1. Disassemble control valve assembly. Refer to AT-293. 2. Check line pressure circuit valves for sticking. <ul style="list-style-type: none">● Pressure regulator valve● Pilot valve● Pressure modifier valve	
	
SAT367H	
OK or NG	
OK	▶ GO TO 8.
NG	▶ Repair control valve.

8	CHECK SHIFT UP (D₃ TO D₄)
Does A/T shift from D ₃ to D ₄ at the specified speed?	
OK or NG	
OK	▶ GO TO 9.
NG	▶ Check control valve again. Repair or replace control valve assembly.

9	CHECK DTC
Perform Diagnostic Trouble Code (DTC) confirmation procedure, AT-145.	
OK or NG	
OK	▶ INSPECTION END
NG	▶ Perform "Cruise test — Part 1" again and return to the start point of this flow chart.

DTC P0734 IMPROPER SHIFTING TO 4TH GEAR POSITION

Component Inspection

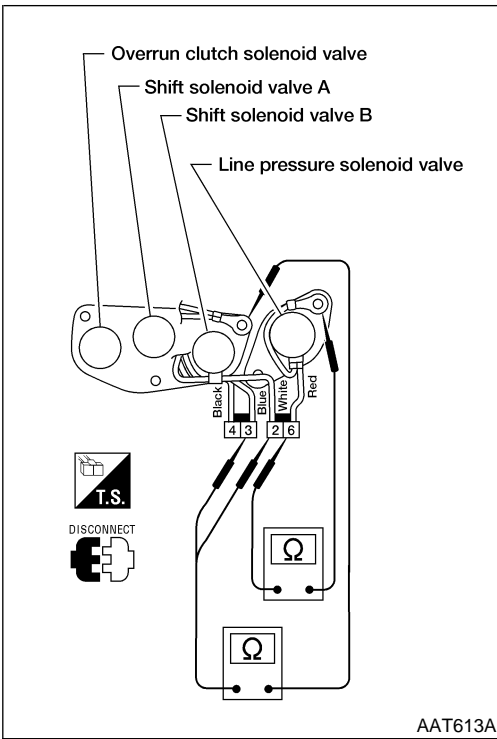

Component Inspection

NGAT0050

SOLENOID VALVES

NGAT0050S01

- For removal, refer to AT-267.

Resistance Check

NGAT0050S0102

- Check resistance between terminals (3, 2 or 6) and ground.

Solenoid valve	Terminal No.	Resistance (Approx.)
Shift solenoid valve A	3	20 - 40Ω
Shift solenoid valve B	2	
Line pressure solenoid valve	6	2.5 - 5Ω

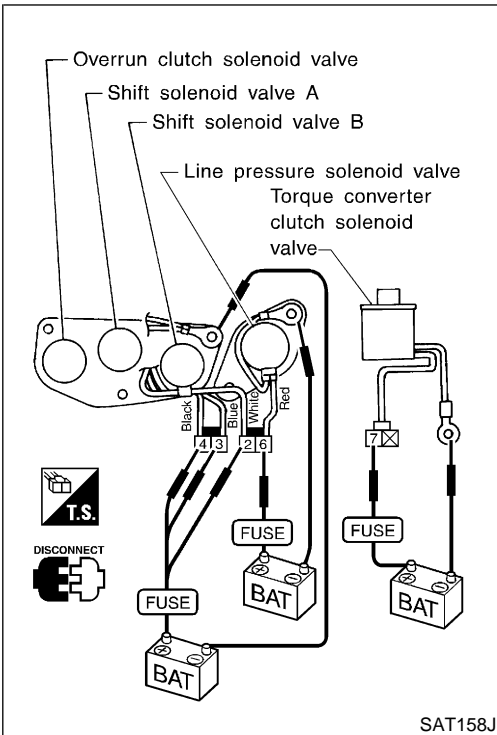

Operation Check

NGAT0050S0102

- Check solenoid valve by listening for its operating sound while applying battery voltage to the terminals (3, 2, 4, 6 or 7) and ground.

GI

MA

EM

LC

EC

FE

CL

MT

AT

TF

PD

AX

SU

BR

ST

RS

BT

HA

SC

EL

IDX

DTC P0740 TORQUE CONVERTER CLUTCH SOLENOID VALVE

Description

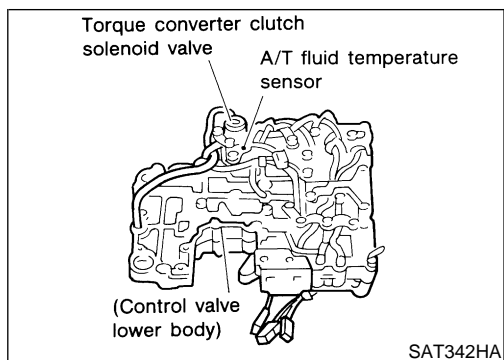

Description

The torque converter clutch solenoid valve is activated, with the gear in "D₄", by the TCM in response to signals sent from the vehicle speed and throttle position sensors. Lock-up piston operation will then be controlled.

Lock-up operation, however, is prohibited when A/T fluid temperature is too low.

When the accelerator pedal is depressed (less than 2/8) in lock-up condition, the engine speed should not change abruptly. If there is a big jump in engine speed, there is no lock-up.

CONSULT-II REFERENCE VALUE IN DATA MONITOR MODE

Remarks: Specification data are reference values.

NGAT0051S02

Monitor item	Condition	Specification (Approx.)
Torque converter clutch solenoid valve duty	Lock-up OFF	4%
	↓ Lock-up ON	↓ 94%

TCM TERMINALS AND REFERENCE VALUE

Remarks: Specification data are reference values.

NGAT0051S03

Terminal No.	Wire color	Item	Condition	Judgement standard (Approx.)
3	G/OR	Torque converter clutch solenoid valve	 When A/T performs lock-up.	8 - 15V
			When A/T does not perform lock-up.	0V

ON BOARD DIAGNOSIS LOGIC

NGAT0051S04

Diagnostic trouble code	Malfunction is detected when ...	Check item (Possible cause)
(P) : TCC SOLENOID/CIRC (P) : P0740	TCM detects an improper voltage drop when it tries to operate the solenoid valve.	<ul style="list-style-type: none"> • Harness or connectors (The solenoid circuit is open or shorted.) • T/C clutch solenoid valve

DTC P0740 TORQUE CONVERTER CLUTCH SOLENOID VALVE

Description (Cont'd)

SELECT SYSTEM
A/T
ENGINE

SAT014K

SELECT DIAG MODE
WORK SUPPORT
SELF-DIAG RESULTS
DATA MONITOR
DATA MONITOR (SPEC)
ACTIVE TEST
DTC & SRT CONFIRMATION

SEF949Y

DIAGNOSTIC TROUBLE CODE (DTC) CONFIRMATION PROCEDURE

NGAT0051S01

NOTE:

If "DIAGNOSTIC TROUBLE CODE CONFIRMATION PROCEDURE" has been previously conducted, always turn ignition switch OFF and wait at least 5 seconds before conducting the next test.

After the repair, perform the following procedure to confirm the malfunction is eliminated.

Ⓜ With CONSULT-II

- 1) Turn ignition switch ON.
- 2) Select "DATA MONITOR" mode for "ENGINE" with CONSULT-II and wait at least 1 second.

Ⓜ With GST

Follow the procedure "With CONSULT-II".

GI

MA

EM

LC

EC

FE

CL

MT

AT

TF

PD

AX

SU

BR

ST

RS

BT

HA

SC

EL

IDX

DTC P0740 TORQUE CONVERTER CLUTCH SOLENOID VALVE

Wiring Diagram — AT — TCV

Wiring Diagram — AT — TCV

NGAT0194

AT-TCV-01

: Detectable line for DTC
 : Non-detectable line for DTC

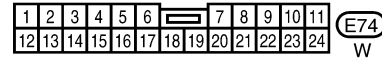
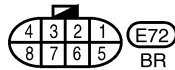
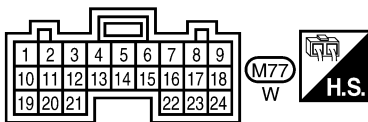
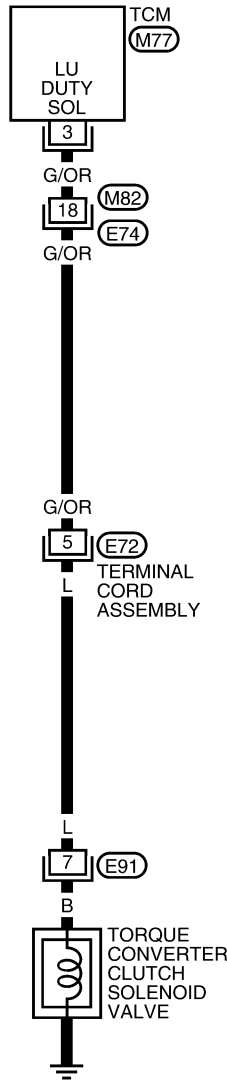

* : This connector is not shown in "HARNESS LAYOUT" of EL section.

LAT504

DTC P0740 TORQUE CONVERTER CLUTCH SOLENOID VALVE

Diagnostic Procedure

Diagnostic Procedure

NGAT0052

1	CHECK GROUND CIRCUIT	
1. Turn ignition switch to OFF position. 2. Disconnect terminal cord assembly connector in engine compartment. 3. Check resistance between terminal cord assembly connector E72 terminal 5 and ground. Refer to wiring diagram. <p style="text-align: center;">Is resistance approx. 10 - 20 Ω?</p>		
Yes	▶	GO TO 2.
No	▶	1. Remove oil pan. Refer to AT-267. 2. Check the following items: <ul style="list-style-type: none"> ● Torque converter clutch solenoid valve Refer to "Component Inspection", AT-156. ● Harness of terminal cord assembly for short or open

GI
MA
EM
LC
EC

2	CHECK RESISTANCE	
1. Turn ignition switch to OFF position. 2. Disconnect TCM harness connector. 3. Check resistance between terminal cord assembly connector E72 terminal 5 and TCM harness connector M77 terminal 3. Refer to wiring diagram. If OK, check harness for short to ground and short to power. <p style="text-align: center;">Is resistance approx. 0Ω?</p>		
Yes	▶	GO TO 3.
No	▶	Repair open circuit or short to ground or short to power in harness or connectors.

FE
CL
MT

AT

3	CHECK DTC	
Perform Diagnostic Trouble Code (DTC) confirmation procedure, AT-153. <p style="text-align: center;">OK or NG</p>		
OK	▶	INSPECTION END
NG	▶	1. Perform TCM input/output signal inspection. 2. If NG, recheck TCM pin terminals for damage or loose connection with harness connector.

TF
PD
AX
SU

BR

ST

RS

BT

HA

SC

EL

IDX

DTC P0740 TORQUE CONVERTER CLUTCH SOLENOID VALVE

Component Inspection

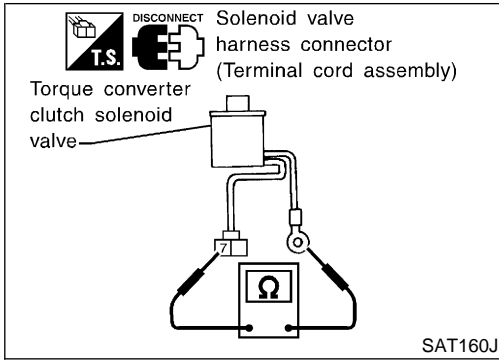

Component Inspection

TORQUE CONVERTER CLUTCH SOLENOID VALVE

=NGAT0053

NGAT0053S01

- For removal, refer to AT-267.

Resistance Check

NGAT0053S0101

- Check resistance between terminal 7 and ground.

Solenoid valve	Terminal No.		Resistance (Approx.)
Torque converter clutch solenoid valve	7	Ground	10 - 20Ω

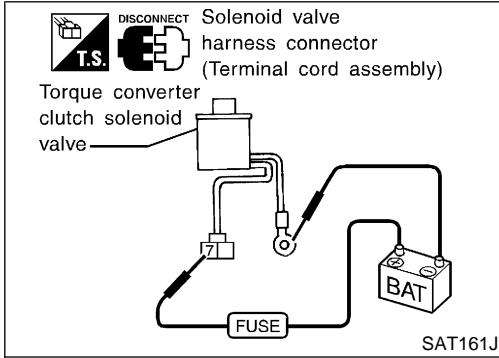

Operation Check

NGAT0053S0102

- Check solenoid valve by listening for its operating sound while applying battery voltage to the terminal 7 and ground.

DTC P0744 IMPROPER LOCK-UP OPERATION

Description

Description

- This is an OBD-II self-diagnostic item and not available in TCM self-diagnosis. NGAT0054
- This malfunction will not be detected while the O/D OFF indicator lamp is indicating another self-diagnosis malfunction. GI
- This malfunction is detected when the A/T does not shift into fourth gear position or the torque converter clutch does not lock up as instructed by the TCM. This is not caused by electrical malfunction (circuits open or shorted) but by mechanical malfunction such as control valve sticking, improper solenoid valve operation, malfunctioning oil pump or torque converter clutch, etc. MA
EM
LC

CONSULT-II REFERENCE VALUE IN DATA MONITOR MODE

NGAT0054S02



Remarks: Specification data are reference values.

Monitor item	Condition	Specification (Approx.)
Torque converter clutch solenoid valve duty	Lock-up OFF	4%
	↓	↓
	Lock-up ON	94%

TCM TERMINALS AND REFERENCE VALUE

NGAT0054S03

Remarks: Specification data are reference values.

Terminal No.	Wire color	Item	Condition	Judgement standard (Approx.)	
1	GY/R	Line pressure solenoid valve		When releasing accelerator pedal after warming up engine.	1.5 - 2.5V
				When depressing accelerator pedal fully after warming up engine.	0V
2	BR/Y	Line pressure solenoid valve (with dropping resistor)		When releasing accelerator pedal after warming up engine.	5 - 14V
				When depressing accelerator pedal fully after warming up engine.	0V
3	G/OR	Torque converter clutch solenoid valve		When A/T performs lock-up.	8 - 15V
				When A/T does not perform lock-up.	0V

ON BOARD DIAGNOSIS LOGIC

NGAT0054S04

This diagnosis monitors actual gear position by checking the torque converter slip ratio calculated by TCM as follows:

Torque converter slip ratio = A x C/B

A: Output shaft revolution signal from revolution sensor

B: Engine speed signal from ECM

C: Gear ratio determined as gear position which TCM supposes

If the actual gear position is much lower than the position (4th) supposed by TCM, the slip ratio will be much less than normal. In case the ratio does not reach the specified value, TCM judges this diagnosis malfunction. BT
HA

This malfunction will be caused when shift solenoid valve B is stuck closed. SC

Gear position supposed by TCM	1	2	3	4
In case of gear position with no malfunctions	1	2	3	4

DTC P0744 IMPROPER LOCK-UP OPERATION

Description (Cont'd)

In case of gear position with shift solenoid valve B stuck closed	1	2	2	1*
---	---	---	---	----

*: P0744 is detected.

Diagnostic trouble code	Malfunction is detected when ...	Check item (Possible cause)
(P) : A/T TCC S/V FNCTN (GST) : P0744	A/T cannot perform lock-up even if electrical circuit is good.	<ul style="list-style-type: none"> • Line pressure solenoid valve • Torque converter clutch solenoid valve • Each clutch • Hydraulic control circuit

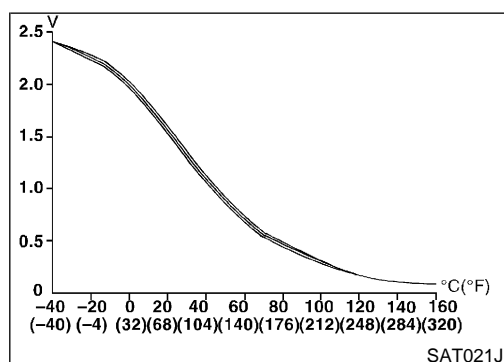
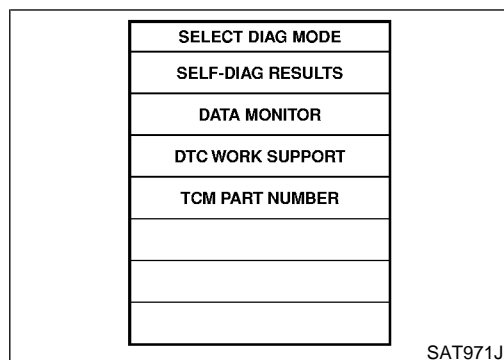
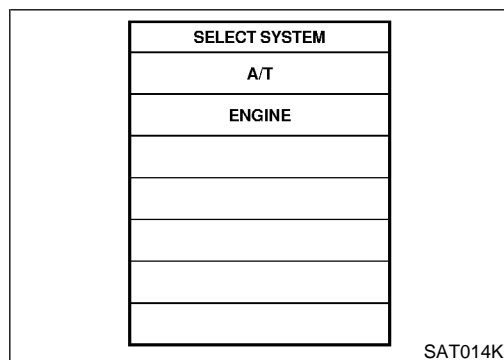

DIAGNOSTIC TROUBLE CODE (DTC) CONFIRMATION PROCEDURE

NGAT0054S01

CAUTION:

Always drive vehicle at a safe speed.

NOTE:

If "DIAGNOSTIC TROUBLE CODE CONFIRMATION PROCEDURE" has been previously conducted, always turn ignition switch OFF and wait at least 5 seconds before conducting the next test.

After the repair, perform the following procedure to confirm the malfunction is eliminated.

(P) With CONSULT-II

- 1) Start engine and select "DATA MONITOR" mode for "A/T" with CONSULT-II.
- 2) Make sure that output voltage of A/T fluid temperature sensor is within the range below.

FLUID TEMP SEN: 0.4 - 1.5V

If out of range, drive the vehicle to decrease the voltage (warm up the fluid) or stop engine to increase the voltage (cool down the fluid).

- 3) Select "TCC S/V FNCTN P0744" of "DTC WORK SUPPORT" mode for "A/T" with CONSULT-II and touch "START".
- 4) Accelerate vehicle to more than 70 km/h (43 MPH) and maintain the following condition continuously until "TESTING" has turned to "COMPLETED". (It will take approximately 30 seconds after "TESTING" shows.)

THROTTLE POSI: 1/8 - 2/8 (at all times during step 4)

Selector lever: D position (O/D ON)

TCC S/V DUTY: More than 94%

VHCL/S SE-A/T: Constant speed of more than 70 km/h (43 MPH)

- Check that "GEAR" shows 4.
 - For shift schedule, refer to "SERVICE DATA AND SPECIFICATIONS (SDS)", AT-348.
 - If "TESTING" does not appear on CONSULT-II for a long time, select "SELF-DIAG RESULTS". In case a 1st trip DTC other than P0744 is shown, refer to applicable "TROUBLE DIAGNOSIS FOR DTC".
- 5) Make sure that "OK" is displayed. (If "NG" is displayed, refer to "DIAGNOSTIC PROCEDURE".)
Refer to "DIAGNOSTIC PROCEDURE", AT-160.
Refer to "Shift Schedule", AT-348.

(GST) With GST

Follow the procedure "With CONSULT-II".

DTC P0744 IMPROPER LOCK-UP OPERATION

Wiring Diagram — AT — TCCSIG

Wiring Diagram — AT — TCCSIG

NGAT0195

AT-TCCSIG-01

: Detectable line for DTC
 : Non-detectable line for DTC

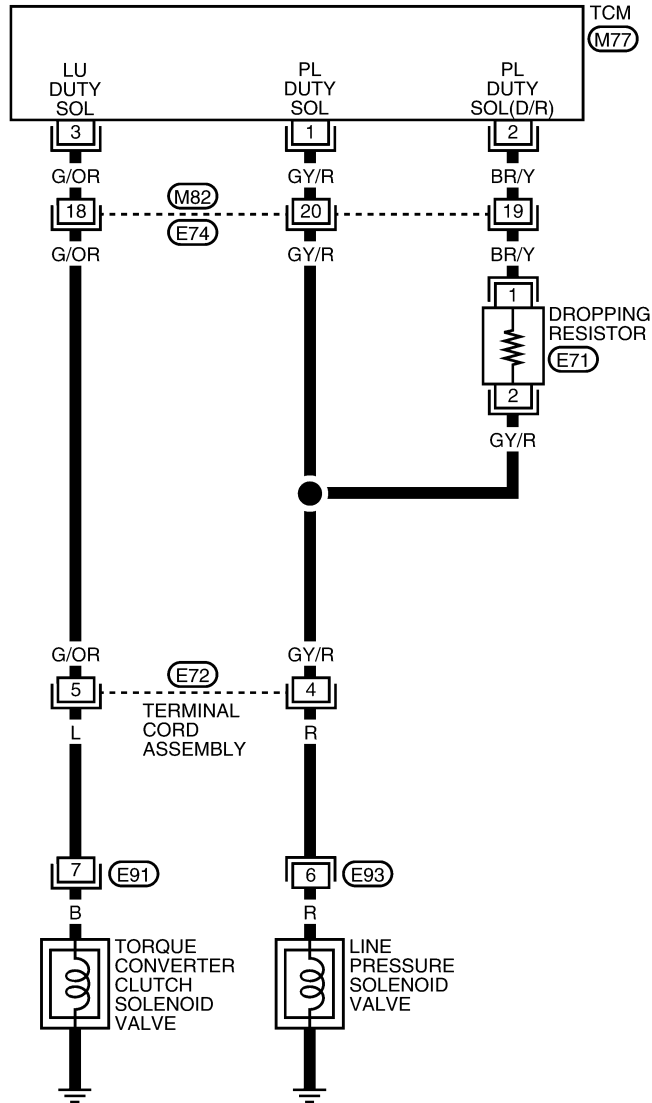

GI
MA
EM
LC
EC
FE
CL
MT
AT
TF
PD
AX
SU
BR
ST
RS
BT
HA
SC
EL
IDX

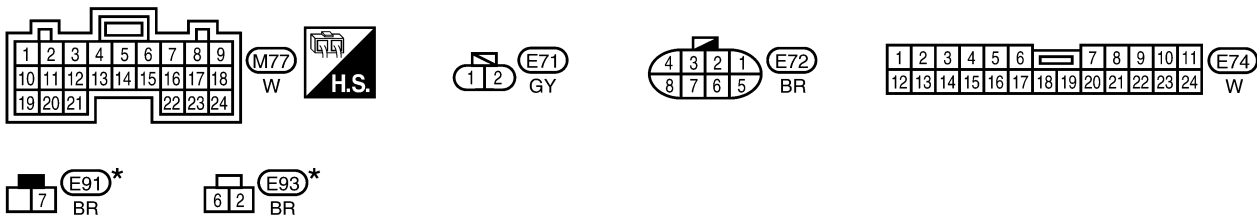

* : This connector is not shown in "HARNESS LAYOUT" of EL section.

DTC P0744 IMPROPER LOCK-UP OPERATION

Diagnostic Procedure

Diagnostic Procedure

=NGAT0055

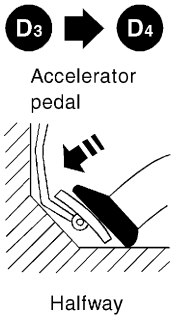
1	CHECK SHIFT UP (D₃ TO D₄)	
<p>During "Cruise test – Part 1", AT-74. Does A/T shift from D₃ to D₄ at the specified speed?</p> <div style="text-align: center;">  <p>Accelerator pedal</p> <p>Halfway</p> </div> <p>Yes or No</p>		
Yes	▶	Check for proper lock-up. GO TO 10.
No	▶	GO TO 2.

SAT988H

2	CHECK LINE PRESSURE	
<p>Perform line pressure test. Refer to AT-65.</p> <p style="text-align: center;">OK or NG</p>		
OK	▶	GO TO 3.
NG	▶	GO TO 6.

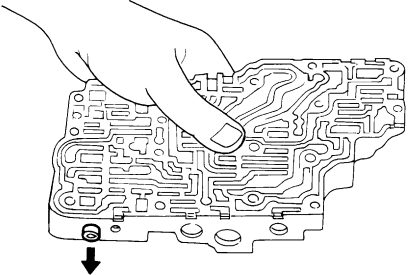
3	CHECK CONTROL VALVE	
<p>1. Disassemble control valve assembly. Refer to "Control Valve Assembly", AT-293. 2. Check to ensure that:</p> <ul style="list-style-type: none"> ● Valve, sleeve and plug slide along valve bore under their own weight. ● Valve, sleeve and plug are free from burrs, dents and scratches. ● Control valve springs are free from damage, deformation and fatigue. ● Hydraulic line is free from obstacles. <div style="text-align: center;">  </div> <p style="text-align: center;">OK or NG</p>		
OK	▶	GO TO 4.
NG	▶	Repair control valve.

SAT367H

DTC P0744 IMPROPER LOCK-UP OPERATION

Diagnostic Procedure (Cont'd)

4	CHECK SHIFT UP (D₃ TO D₄)
Does A/T shift from D ₃ to D ₄ at the specified speed?	
Yes or No	
Yes	▶ GO TO 5.
No	▶ Check control valve again. Repair or replace control valve assembly.

5	CHECK DTC
Perform Diagnostic Trouble Code (DTC) confirmation procedure. Refer to "DIAGNOSTIC TROUBLE CODE (DTC) CONFIRMATION PROCEDURE", AT-158.	
OK or NG	
OK	▶ INSPECTION END
NG	▶ Check for proper lock-up. GO TO 10.

6	CHECK LINE PRESSURE SOLENOID VALVE
1. Remove control valve assembly. Refer to "Control Valve Assembly and Accumulators", AT-267. 2. Check line pressure solenoid valve operation. Refer to "SOLENOID VALVES", AT-163.	
OK or NG	
OK	▶ GO TO 7.
NG	▶ Replace solenoid valve assembly.

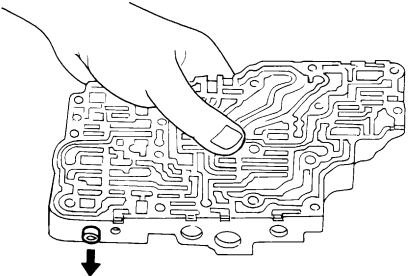
7	CHECK CONTROL VALVE
1. Disassemble control valve assembly. Refer to "Control Valve Assembly", AT-293. 2. Check line pressure circuit valves for sticking.	
<ul style="list-style-type: none"> ● Pressure regulator valve ● Pilot valve ● Pressure modifier valve 	
	
SAT367H	
OK or NG	
OK	▶ GO TO 8.
NG	▶ Repair control valve.

8	CHECK SHIFT UP (D₃ TO D₄)
Does A/T shift from D ₃ to D ₄ at the specified speed?	
Yes or No	
Yes	▶ GO TO 9.
No	▶ Check control valve again. Repair or replace control valve assembly.

GI
MA
EM
LC
EC
FE
CL
MT
AT
TF
PD
AX
SU
BR
ST
RS
BT
HA
SC
EL
IDX

DTC P0744 IMPROPER LOCK-UP OPERATION

Diagnostic Procedure (Cont'd)

9	CHECK DTC
Perform Diagnostic Trouble Code (DTC) confirmation procedure. Refer to "DIAGNOSTIC TROUBLE CODE (DTC) CONFIRMATION PROCEDURE", AT-158.	
OK or NG	
OK	▶ INSPECTION END
NG	▶ Check for proper lock-up. GO TO 10.

10	CHECK LOCK-UP CONDITION
During "Cruise test – Part 1", AT-74, Does A/T perform lock-up at the specified speed?	
Yes or No	
Yes	▶ Perform "Cruise test – Part 1" again and return to the start point of this flow chart.
No	▶ GO TO 11.

11	CHECK TORQUE CONVERTER CLUTCH SOLENOID VALVE
1. Remove control valve assembly. Refer to AT-267. 2. Check torque converter clutch solenoid valve operation. Refer to AT-163.	
OK or NG	
OK	▶ GO TO 12.
NG	▶ Replace solenoid valve assembly.

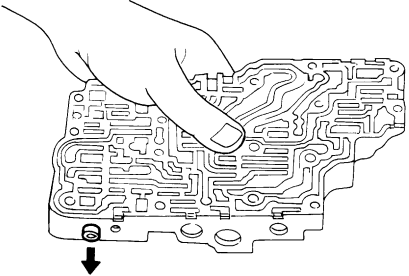
12	CHECK CONTROL VALVE
1. Disassemble control valve assembly. Refer to "Control Valve Assembly", AT-293. 2. Check control valves for sticking. <ul style="list-style-type: none">● Torque converter clutch control valve● Torque converter clutch relief valve	
	
SAT367H	
OK or NG	
OK	▶ GO TO 13.
NG	▶ Repair control valve

13	CHECK LOCK-UP CONDITION
Does A/T perform lock-up at the specified speed?	
Yes or No	
Yes	▶ GO TO 14.
No	▶ Check control valve again. Repair or replace control valve assembly.

DTC P0744 IMPROPER LOCK-UP OPERATION

Diagnostic Procedure (Cont'd)

14	CHECK DTC	
Perform Diagnostic Trouble Code (DTC) confirmation procedure. Refer to "DIAGNOSTIC TROUBLE CODE (DTC) CONFIRMATION PROCEDURE", AT-158.		
OK or NG		
OK	▶	INSPECTION END
NG	▶	Perform "Cruise test — Part 1" again and return to the start point of this flow chart.

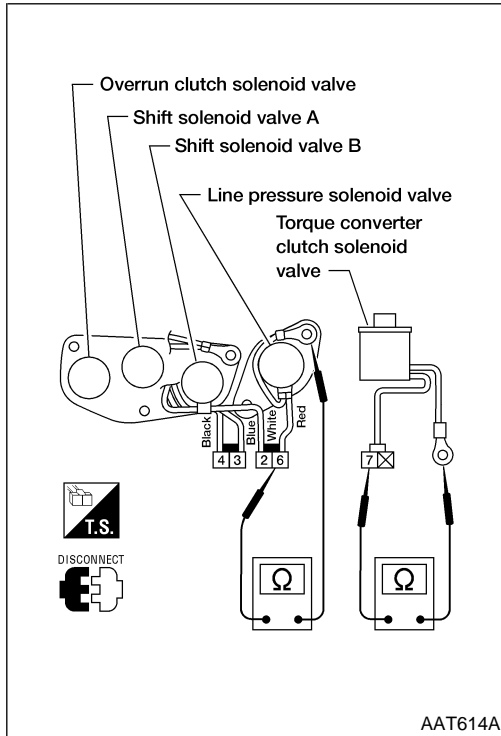

Component Inspection SOLENOID VALVES

NGAT0056

- For removal, refer to "Control Valve Assembly and Accumulators", AT-267.

NGAT0056S01

Resistance Check

NGAT0056S0101

- Check resistance between terminals (6 or 7) and ground.

Solenoid valve	Terminal No.	Resistance (Approx.)
Line pressure solenoid valve	6	Ground 2.5 - 5Ω
Torque converter clutch solenoid valve	7	

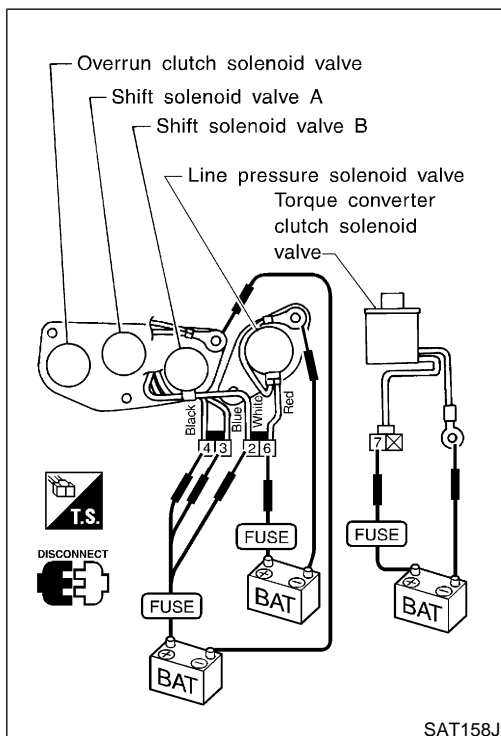

Operation Check

NGAT0056S0102

- Check solenoid valve by listening for its operating sound while applying battery voltage to the terminals (2, 3, 4, 6 or 7) and ground.

GI
MA
EM
LC
EC
FE
CL
MT
AT
TF
PD
AX
SU
BR
ST
RS
BT
HA
SC
EL
IDX

DTC P0745 LINE PRESSURE SOLENOID VALVE

Description

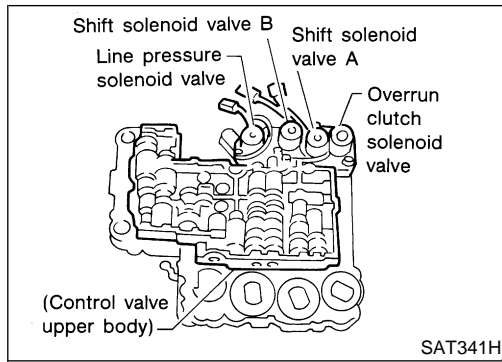

Description

The line pressure solenoid valve regulates the oil pump discharge pressure to suit the driving condition in response to a signal sent from the TCM. NGAT0057

The line pressure duty cycle value is not consistent when the closed throttle position switch is ON. To confirm the line pressure duty cycle at low pressure, the accelerator (throttle) should be open until the closed throttle position switch is OFF.

CONSULT-II REFERENCE VALUE IN DATA MONITOR MODE

NGAT0057S02

Remarks: Specification data are reference values.

Monitor item	Condition	Specification (Approx.)
Line pressure solenoid valve duty	Small throttle opening (Low line pressure)	24%
	↓ Large throttle opening (High line pressure)	↓ 95%

NOTE:

The line pressure duty cycle value is not consistent when the closed throttle position switch is ON. To confirm the line pressure duty cycle at low pressure, the accelerator (throttle) should be open until the closed throttle position switch is OFF.

TCM TERMINALS AND REFERENCE VALUE

NGAT0057S03

Remarks: Specification data are reference values.

Terminal No.	Wire color	Item	Condition	Judgement standard (Approx.)	
1	GY/R	Line pressure solenoid valve		When releasing accelerator pedal after warming up engine.	1.5 - 2.5V
				When depressing accelerator pedal fully after warming up engine.	0V
2	BR/Y	Line pressure solenoid valve (with dropping resistor)		When releasing accelerator pedal after warming up engine.	5 - 14V
				When depressing accelerator pedal fully after warming up engine.	0V

ON BOARD DIAGNOSIS LOGIC

NGAT0057S04

Diagnostic trouble code	Malfunction is detected when ...	Check item (Possible cause)
(P) : L/PRESS SOL/CIRC (GS) : P0745	TCM detects an improper voltage drop when it tries to operate the solenoid valve.	<ul style="list-style-type: none"> • Harness or connectors (The solenoid circuit is open or shorted.) • Line pressure solenoid valve

DTC P0745 LINE PRESSURE SOLENOID VALVE

Description (Cont'd)

SELECT SYSTEM
A/T
ENGINE

SAT014K

SELECT DIAG MODE
WORK SUPPORT
SELF-DIAG RESULTS
DATA MONITOR
DATA MONITOR (SPEC)
ACTIVE TEST
DTC & SRT CONFIRMATION

SEF949Y

DIAGNOSTIC TROUBLE CODE (DTC) CONFIRMATION PROCEDURE

NGAT0057S01

NOTE:

If "DIAGNOSTIC TROUBLE CODE CONFIRMATION PROCEDURE" has been previously conducted, always turn ignition switch OFF and wait at least 5 seconds before conducting the next test.

After the repair, perform the following procedure to confirm the malfunction is eliminated.

With CONSULT-II

- 1) Turn ignition switch ON and select "DATA MONITOR" mode for "ENGINE" with CONSULT-II.
- 2) Depress accelerator pedal completely and wait at least 1 second.

With GST

Follow the procedure "With CONSULT-II".

GI

MA

EM

LC

EC

FE

CL

MT

AT

TF

PD

AX

SU

BR

ST

RS

BT

HA

SC

EL

IDX

DTC P0745 LINE PRESSURE SOLENOID VALVE

Wiring Diagram — AT — LPSV

Wiring Diagram — AT — LPSV

NGAT0196

AT-LPSV-01

: Detectable line for DTC
 : Non-detectable line for DTC

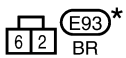
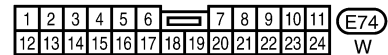
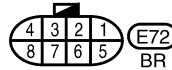
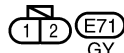
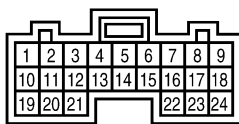
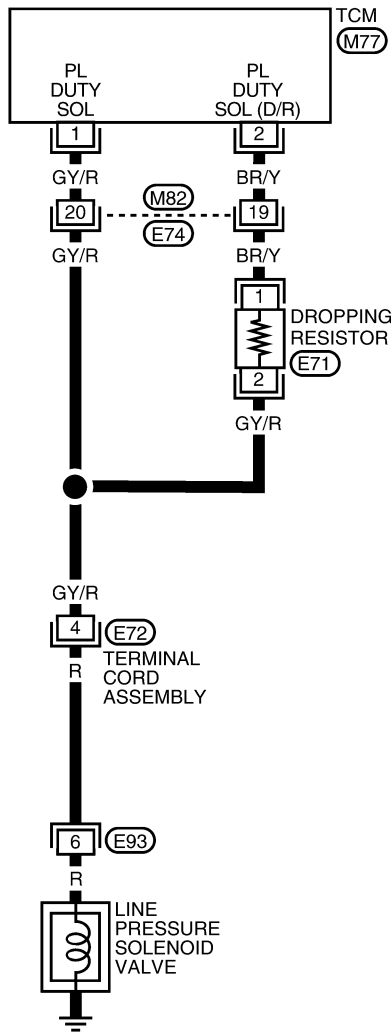

★ : This connector is not shown in "HARNESS LAYOUT" of EL section.

LAT506

DTC P0745 LINE PRESSURE SOLENOID VALVE

Diagnostic Procedure

Diagnostic Procedure

NGAT0058

1	CHECK GROUND CIRCUIT	
<p>1. Turn ignition switch to OFF position. 2. Disconnect terminal cord assembly connector in engine compartment. 3. Check resistance between terminal cord assembly connector E72 terminal 4 and ground. Refer to "Wiring Diagram — AT — LPSV", AT-166.</p> <p style="text-align: center;">Is resistance approx. 2.5 - 5Ω?</p>		
Yes	▶	GO TO 2.
No	▶	<p>1. Remove control valve assembly. Refer to AT-267.</p> <p>2. Check the following items:</p> <ul style="list-style-type: none"> ● Line pressure solenoid valve Refer to "Component Inspection", AT-168. ● Harness of terminal cord assembly for short or open

2	CHECK POWER SOURCE CIRCUIT	
<p>1. Turn ignition switch to OFF position. 2. Disconnect TCM harness connector. 3. Check resistance between terminal cord assembly connector E72 terminal 4 and TCM harness connector M77 terminal 2. Refer to "Wiring Diagram — AT — LPSV", AT-166.</p> <p style="text-align: center;">Is resistance approx. 12Ω?</p>		
Yes	▶	GO TO 3.
No	▶	<p>Check the following items:</p> <ul style="list-style-type: none"> ● Dropping resistor Refer to "Component Inspection", AT-168. ● Harness for short or open between TCM connector M77 terminal 2 and terminal cord assembly.

3	CHECK POWER SOURCE CIRCUIT	
<p>1. Turn ignition switch to OFF position. 2. Check resistance between terminal cord assembly connector E72 terminal 4 and TCM connector M77 terminal 1. Refer to "Wiring Diagram — AT — LPSV", AT-166.</p> <p style="text-align: center;">Is resistance approx. 0Ω?</p>		
Yes	▶	GO TO 4.
No	▶	Repair or replace harness between TCM connector and terminal cord assembly connector.

4	CHECK DTC	
<p>Perform Diagnostic Trouble Code (DTC) confirmation procedure. Refer to "DIAGNOSTIC TROUBLE CODE (DTC) CONFIRMATION PROCEDURE", AT-165.</p> <p style="text-align: center;">OK or NG</p>		
OK	▶	INSPECTION END
NG	▶	<p>1. Perform TCM input/output signal inspection. 2. If NG, recheck TCM pin terminals for damage or loose connection with harness connector.</p>

GI
MA
EM
LC
EC
FE
CL
MT
AT
TF
PD
AX
SU
BR
ST
RS
BT
HA
SC
EL
IDX

DTC P0745 LINE PRESSURE SOLENOID VALVE

Component Inspection

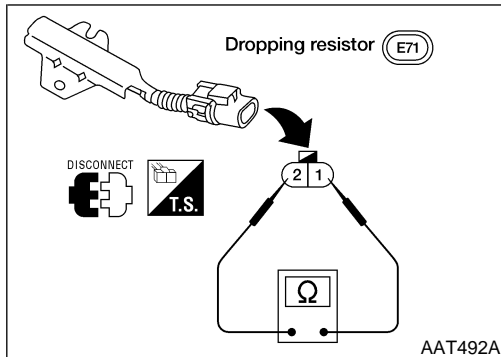
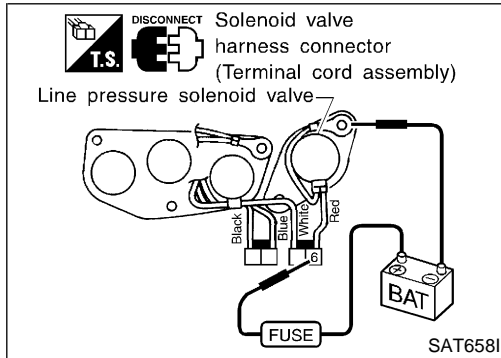
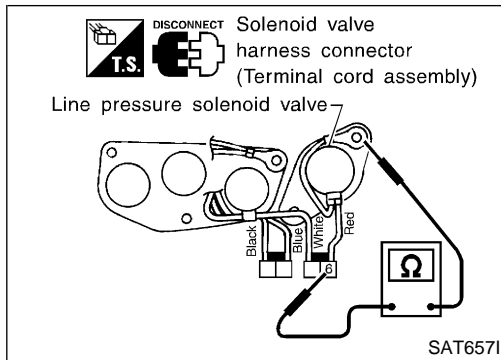

Component Inspection LINE PRESSURE SOLENOID VALVE

=NGAT0059

- For removal, refer to "Control Valve Assembly and Accumulators", AT-267.

NGAT0059S01

Resistance Check

NGAT0059S0101

- Check resistance between terminal 6 and ground.

Solenoid valve	Terminal No.		Resistance (Approx.)
Line pressure solenoid valve	6	Ground	2.5 - 5Ω

Operation Check

NGAT0059S0102

- Check solenoid valve by listening for its operating sound while applying battery voltage to the terminal 6 and ground.

DROPPING RESISTOR

NGAT0059S02

- Check resistance between terminals 1 and 2.

Resistance: Approx. 12Ω

DTC P0750 SHIFT SOLENOID VALVE A

Description

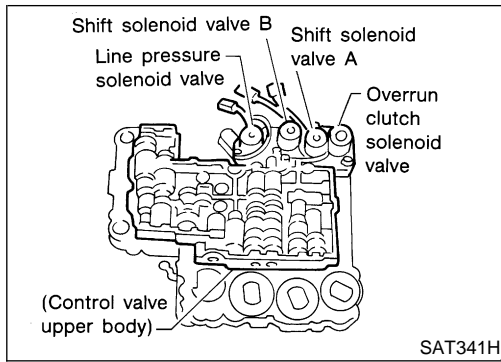

Description

Shift solenoid valves A and B are turned ON or OFF by the TCM ^{NGAT0060} in response to signals sent from the PNP switch, vehicle speed and throttle position sensors. Gears will then be shifted to the optimum position.

Gear position	1	2	3	4
Shift solenoid valve A	ON (Closed)	OFF (Open)	OFF (Open)	ON (Closed)
Shift solenoid valve B	ON (Closed)	ON (Closed)	OFF (Open)	OFF (Open)

TCM TERMINALS AND REFERENCE VALUE

NGAT0060S02

Remarks: Specification data are reference values.

Terminal No.	Wire color	Item	Condition	Judgement standard (Approx.)
11	L/W	Shift solenoid valve A	 When shift solenoid valve A operates. (When driving in D ₁ or D ₄ .)	Battery voltage
			When shift solenoid valve A does not operate. (When driving in D ₂ or D ₃ .)	0V

ON BOARD DIAGNOSIS LOGIC

NGAT0060S03

Diagnostic trouble code	Malfunction is detected when ...	Check item (Possible cause)
(P) : SFT SOL A/CIRC (P) : P0750	TCM detects an improper voltage drop when it tries to operate the solenoid valve.	<ul style="list-style-type: none"> • Harness or connectors (The solenoid circuit is open or shorted.) • Shift solenoid valve A

GI
MA
EM
LC
EC
FE
CL
MT
AT
TF
PD
AX
SU
BR
ST
RS
BT
HA
SC
EL
IDX

DTC P0750 SHIFT SOLENOID VALVE A

Description (Cont'd)

SELECT SYSTEM
A/T
ENGINE

SAT014K

SELECT DIAG MODE
WORK SUPPORT
SELF-DIAG RESULTS
DATA MONITOR
DATA MONITOR (SPEC)
ACTIVE TEST
DTC & SRT CONFIRMATION

SEF949Y

DIAGNOSTIC TROUBLE CODE (DTC) CONFIRMATION PROCEDURE

NGAT0060S01

CAUTION:

Always drive vehicle at a safe speed.

NOTE:

If "DIAGNOSTIC TROUBLE CODE CONFIRMATION PROCEDURE" has been previously conducted, always turn ignition switch OFF and wait at least 5 seconds before conducting the next test.

After the repair, perform the following procedure to confirm the malfunction is eliminated.

With CONSULT-II

- 1) Turn ignition switch ON and select "DATA MONITOR" mode for "ENGINE" with CONSULT-II.
- 2) Start engine.
- 3) Drive vehicle in D position and allow the transmission to shift 1 → 2 ("GEAR").

With GST

Follow the procedure "With CONSULT-II".

DTC P0750 SHIFT SOLENOID VALVE A

Wiring Diagram — AT — SSV/A

Wiring Diagram — AT — SSV/A

NGAT0197

AT-SSV/A-01

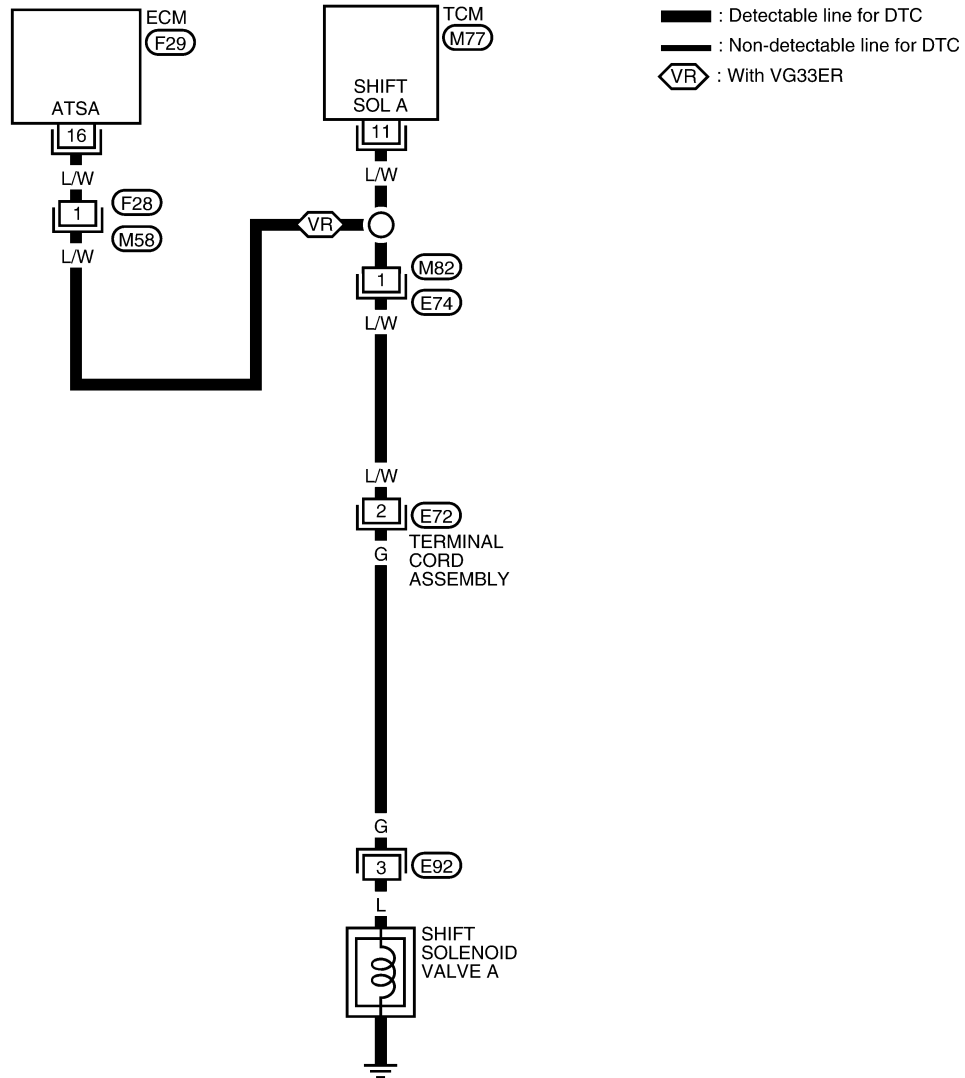

GI
MA
EM
LC
EC
FE
CL
MT
AT
TF
PD
AX
SU
BR
ST
RS
BT
HA
SC
EL
IDX

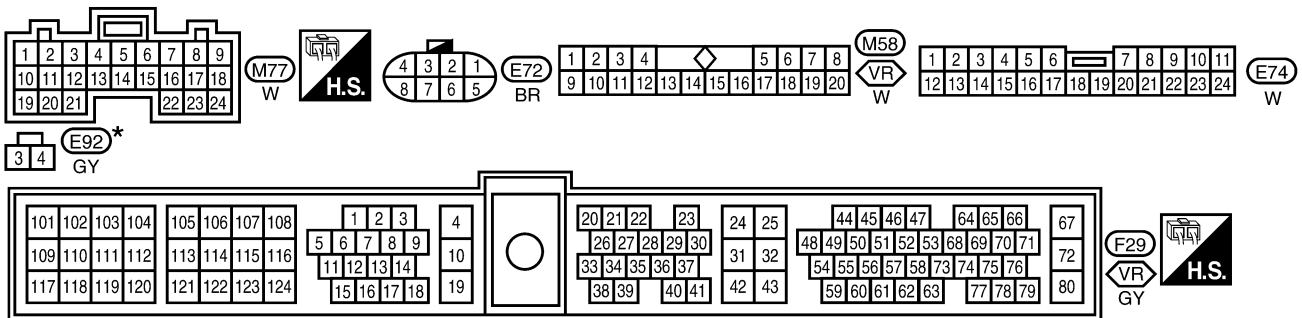

*: This connector is not shown in "HARNESS LAYOUT" of EL section.

WAT476

DTC P0750 SHIFT SOLENOID VALVE A

Diagnostic Procedure

Diagnostic Procedure

NGAT0061

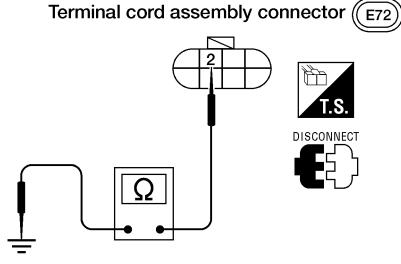
1	CHECK GROUND CIRCUIT	
<p>1. Turn ignition switch to OFF position. 2. Disconnect terminal cord assembly connector in engine compartment. 3. Check resistance between terminal cord assembly connector E72 terminal 2 and ground.</p>		
<p>Terminal cord assembly connector (E72)</p> 		
Is resistance approx. 20 - 40Ω?		
Yes	▶	GO TO 2.
No	▶	<p>1. Remove control valve assembly. Refer to AT-267.</p> <p>2. Check the following items:</p> <ul style="list-style-type: none"> ● Shift solenoid valve A Refer to "Component Inspection", AT-173. ● Harness of terminal cord assembly for short or open

AAT506A

2	CHECK POWER SOURCE CIRCUIT	
<p>1. Turn ignition switch to OFF position. 2. Disconnect TCM harness connector. 3. Check resistance between terminal cord assembly connector terminal 2 and TCM harness connector M77 terminal 11. Refer to wiring diagram.</p> <p>If OK, check harness for short to ground and short to power.</p>		
Is resistance approx. 0Ω?		
Yes	▶	GO TO 3.
No	▶	Repair open circuit or short to ground or short to power in harness or connectors.

3	CHECK DTC	
<p>Perform Diagnostic Trouble Code (DTC) confirmation procedure. Refer to "DIAGNOSTIC TROUBLE CODE (DTC) CONFIRMATION PROCEDURE", AT-170.</p>		
OK or NG		
OK	▶	INSPECTION END
NG	▶	<p>1. Perform TCM input/output signal inspection. 2. If NG, recheck TCM pin terminals for damage or loose connection with harness connector.</p>

DTC P0750 SHIFT SOLENOID VALVE A

Component Inspection

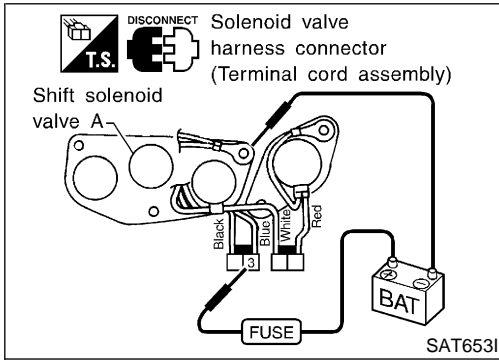
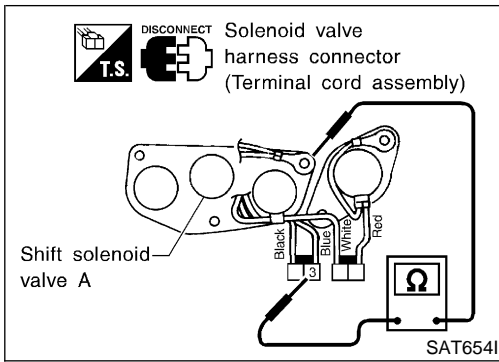

Component Inspection

SHIFT SOLENOID VALVE A

=NGAT0062

NGAT0062S01

- For removal, refer to “Control Valve Assembly and Accumulators”, AT-267.

Resistance Check

NGAT0062S0101

- Check resistance between terminal 3 and ground.

Solenoid valve	Terminal No.		Resistance (Approx.)
Shift solenoid valve A	3	Ground	20 - 40Ω

Operation Check

NGAT0062S0102

- Check solenoid valve by listening for its operating sound while applying battery voltage to the terminal 3 and ground.

GI

MA

EM

LC

EC

FE

CL

MT

AT

TF

PD

AX

SU

BR

ST

RS

BT

HA

SC

EL

IDX

DTC P0755 SHIFT SOLENOID VALVE B

Description

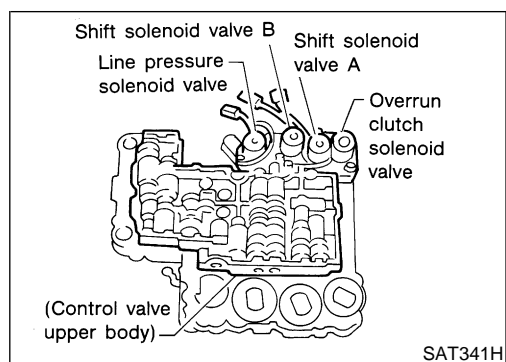

Description

Shift solenoid valves A and B are turned ON or OFF by the TCM ^{NGAT0063} in response to signals sent from the PNP switch, vehicle speed and throttle position sensors. Gears will then be shifted to the optimum position.

Gear position	1	2	3	4
Shift solenoid valve A	ON (Closed)	OFF (Open)	OFF (Open)	ON (Closed)
Shift solenoid valve B	ON (Closed)	ON (Closed)	OFF (Open)	OFF (Open)

TCM TERMINALS AND REFERENCE VALUE

NGAT0063S02

Remarks: Specification data are reference values.

Terminal No.	Wire color	Item	Condition	Judgement standard (Approx.)
12	LY	Shift solenoid valve B	 When shift solenoid valve B operates. (When driving in D ₁ or D ₂ .)	Battery voltage
			When shift solenoid valve B does not operate. (When driving in D ₃ or D ₄ .)	0V

ON BOARD DIAGNOSIS LOGIC

NGAT0063S03

Diagnostic trouble code	Malfunction is detected when ...	Check item (Possible cause)
(P) : SFT SOL B/CIRC (P) : P0755	TCM detects an improper voltage drop when it tries to operate the solenoid valve.	<ul style="list-style-type: none"> • Harness or connectors (The solenoid circuit is open or shorted.) • Shift solenoid valve B

DTC P0755 SHIFT SOLENOID VALVE B

Description (Cont'd)

SELECT SYSTEM
A/T
ENGINE

SAT014K

SELECT DIAG MODE
WORK SUPPORT
SELF-DIAG RESULTS
DATA MONITOR
DATA MONITOR (SPEC)
ACTIVE TEST
DTC & SRT CONFIRMATION

SEF949Y

DIAGNOSTIC TROUBLE CODE (DTC) CONFIRMATION PROCEDURE

NGAT0063S01

CAUTION:

Always drive vehicle at a safe speed.

NOTE:

If "DIAGNOSTIC TROUBLE CODE CONFIRMATION PROCEDURE" has been previously conducted, always turn ignition switch OFF and wait at least 5 seconds before conducting the next test.

After the repair, perform the following procedure to confirm the malfunction is eliminated.

Ⓜ With CONSULT-II

- 1) Turn ignition switch ON and select "DATA MONITOR" mode for "ENGINE" with CONSULT-II.
- 2) Drive vehicle in D position and allow the transmission to shift 1 → 2 → 3 ("GEAR").

Ⓜ With GST

Follow the procedure "With CONSULT-II".

GI

MA

EM

LC

EC

FE

CL

MT

AT

TF

PD

AX

SU

BR

ST

RS

BT

HA

SC

EL

IDX

DTC P0755 SHIFT SOLENOID VALVE B

Wiring Diagram — AT — SSV/B

Wiring Diagram — AT — SSV/B

NGAT0198

AT-SSV/B-01

: Detectable line for DTC
 : Non-detectable line for DTC

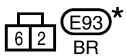
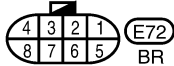
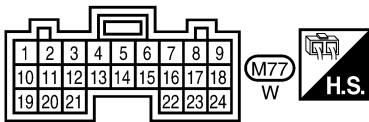
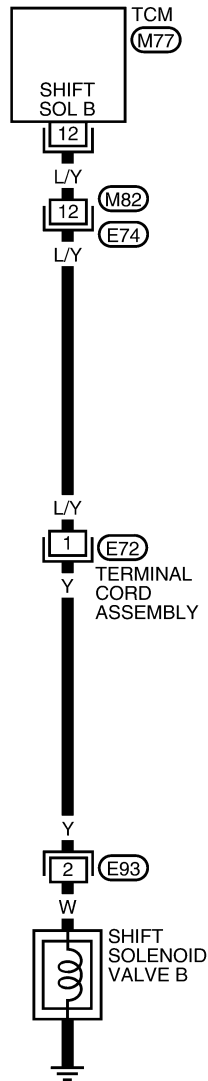

* : This connector is not shown in "HARNES LAYOUT" of EL section.

DTC P0755 SHIFT SOLENOID VALVE B

Diagnostic Procedure

Diagnostic Procedure

NGAT0064

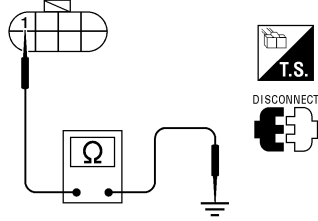
1	CHECK GROUND CIRCUIT	
<p>1. Turn ignition switch to OFF position. 2. Disconnect terminal cord assembly connector in engine compartment. 3. Check resistance between terminal cord assembly connector E72 terminal 1 and ground.</p> <p style="text-align: center;">Terminal cord assembly connector (E72)</p>  <p style="text-align: right;">AAT508A</p> <p style="text-align: center;">Is resistance approx. 20 - 40Ω?</p>		
Yes	▶	GO TO 2.
No	▶	<p>1. Remove control valve assembly. Refer to AT-267.</p> <p>2. Check the following items:</p> <ul style="list-style-type: none"> ● Shift solenoid valve B ● Refer to "Component Inspection", AT-178. ● Harness of terminal cord assembly for short or open

GI
MA
EM
LC
EC
FE
CL
MT
AT

2	CHECK POWER SOURCE CIRCUIT	
<p>1. Turn ignition switch to OFF position. 2. Disconnect TCM harness connector. 3. Check resistance between terminal cord assembly connector E72 terminal 1 and TCM harness connector M77 terminal 12. Refer to wiring diagram. If OK, check harness for short to ground and short to power.</p> <p style="text-align: center;">Is resistance approx. 0Ω?</p>		
Yes	▶	GO TO 3.
No	▶	Repair open circuit or short to ground or short to power in harness or connectors.

TF
PD
AX
SU

3	CHECK DTC	
<p>Perform Diagnostic Trouble Code (DTC) confirmation procedure. Refer to "DIAGNOSTIC TROUBLE CODE (DTC) CONFIRMATION PROCEDURE", AT-175.</p> <p style="text-align: center;">OK or NG</p>		
OK	▶	INSPECTION END
NG	▶	<p>1. Perform TCM input/output signal inspection. 2. If NG, recheck TCM pin terminals for damage or loose connection with harness connector.</p>

BR
ST
RS
BT

HA
SC
EL
IDX

DTC P0755 SHIFT SOLENOID VALVE B

Component Inspection

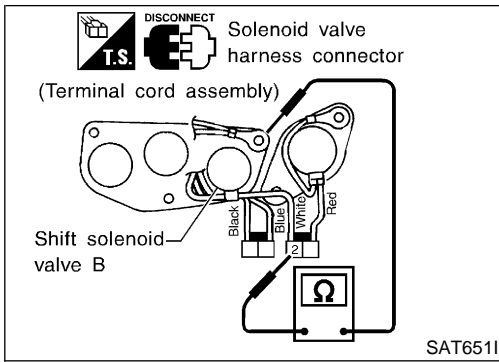

Component Inspection SHIFT SOLENOID VALVE B

=NGAT0065

NGAT0065S01

- For removal, refer to "REMOVAL", AT-267.

Resistance Check

NGAT0065S0101

- Check resistance between terminal 2 and ground.

Solenoid valve	Terminal No.		Resistance (Approx.)
Shift solenoid valve B	2	Ground	20 - 40 Ω

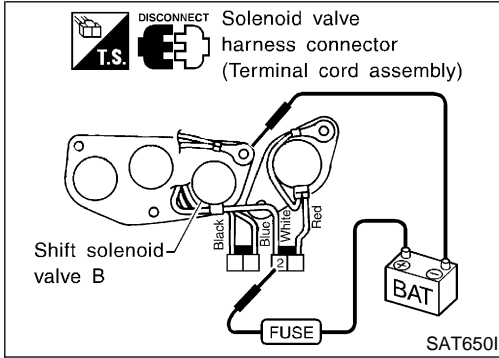

Operation Check

NGAT0065S0102

- Check solenoid valve by listening for its operating sound while applying battery voltage to the terminal 2 and ground.

DTC P1705 THROTTLE POSITION SENSOR

Description

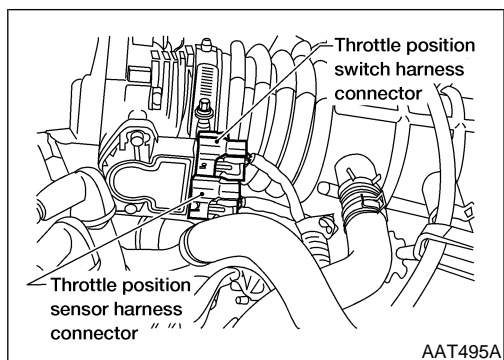

Description

NGAT0066

- Throttle position sensor
The throttle position sensor detects the throttle valve position and sends a signal to the TCM.
- Throttle position switch
Consists of a wide open throttle position switch and a closed throttle position switch. The wide open position switch sends a signal to the TCM when the throttle valve is open at least 1/2 of the full throttle position. The closed throttle position switch sends a signal to the TCM when the throttle valve is fully closed.

CONSULT-II REFERENCE VALUE IN DATA MONITOR MODE

NGAT0066S02

Remarks: Specification data are reference values.

Monitor item	Condition	Specification (Approx.)
Throttle position sensor	Fully-closed throttle	0.5V
	Fully-open throttle	4V

TCM TERMINALS AND REFERENCE VALUE

NGAT0066S03

Remarks: Specification data are reference values.

Terminal No.	Wire color	Item	Condition	Judgement standard (Approx.)	
16	BR/W	Closed throttle position switch (in throttle position switch)		When releasing accelerator pedal after warming up engine.	Battery voltage
				When depressing accelerator pedal after warming up engine.	0V
17	OR/B	Wide open throttle position switch (in throttle position switch)		When depressing accelerator pedal more than half-way after warming up engine.	Battery voltage
				When releasing accelerator pedal after warming up engine.	0V
32	B/W	Throttle position sensor (Power source)	or	Ignition switch ON.	4.5 - 5.5V
				Ignition switch OFF.	0V
41	OR/L	Throttle position sensor		When depressing accelerator pedal slowly after warming up engine. (Voltage rises gradually in response to throttle position.)	Fully-closed throttle: 0.5V Fully-open throttle: 4V
42	BR	Throttle position sensor (Ground)		—	0V

DTC P1705 THROTTLE POSITION SENSOR

Description (Cont'd)

ON BOARD DIAGNOSIS LOGIC

NGAT0066S04

Diagnostic trouble code	Malfunction is detected when ...	Check item (Possible cause)
④ : TP SEN/CIRC A/T ④ : P1705	TCM receives an excessively low or high voltage from the sensor.	<ul style="list-style-type: none"> • Harness or connectors (The solenoid circuit is open or shorted.) • Throttle position sensor • Throttle position switch

SELECT SYSTEM
A/T
ENGINE

SAT014K

DIAGNOSTIC TROUBLE CODE (DTC) CONFIRMATION PROCEDURE

NGAT0066S01

CAUTION:

Always drive vehicle at a safe speed.

NOTE:

If "DIAGNOSTIC TROUBLE CODE CONFIRMATION PROCEDURE" has been previously conducted, always turn ignition switch OFF and wait at least 5 seconds before conducting the next test.

After the repair, perform the following procedure to confirm the malfunction is eliminated.

SELECT DIAG MODE
SELF-DIAG RESULTS
DATA MONITOR
DTC WORK SUPPORT
TCM PART NUMBER

SAT971J

④ With CONSULT-II

- 1) Turn ignition switch ON and select "DATA MONITOR" mode for "A/T" with CONSULT-II.
- 2) Apply vacuum to the throttle opener, then check the following. Refer to step 1 and step 2 of "Preparation", "TCM SELF-DIAGNOSIS PROCEDURE (NO TOOLS)", AT-47.

Accelerator pedal condition	THRTL POS SEN	CLOSED THL/SW	W/O THRL/P-SW
Fully released	Less than 4.7V	ON	OFF
Partially depressed	0.1 - 4.6V	OFF	OFF
Fully depressed	More than 1.9 - 4.6V	OFF	ON

SELECT SYSTEM
A/T
ENGINE

SAT014K

If the check result is NG, go to "DIAGNOSTIC PROCEDURE", AT-183.

If the check result is OK, go to following step.

- 3) Turn ignition switch ON and select "DATA MONITOR" mode for "ENGINE" with CONSULT-II.
- 4) Start engine and maintain the following conditions for at least 3 consecutive seconds. Then release accelerator pedal completely.

VHCL SPEED SE: 10 km/h (6 MPH) or more

THRTL POS SEN: Approximately 3V or less

Selector lever: D position (O/D ON)

If the check result is NG, go to "DIAGNOSTIC PROCEDURE", AT-183.

If the check result is OK, go to following step.

- 5) Maintain the following conditions for at least 3 consecutive seconds. Then release accelerator pedal completely.

VHCL SPEED SE: 10 km/h (6 MPH) or more

Accelerator pedal: Wide open throttle

Selector lever: D position (O/D ON)

SELECT DIAG MODE
WORK SUPPORT
SELF-DIAG RESULTS
DATA MONITOR
DATA MONITOR (SPEC)
ACTIVE TEST
DTC & SRT CONFIRMATION

SEF949Y

DTC P1705 THROTTLE POSITION SENSOR

Description (Cont'd)

 With GST

Follow the procedure "With CONSULT-II".

GI

MA

EM

LC

EC

FE

CL

MT

AT

TF

PD

AX

SU

BR

ST

RS

BT

HA

SC

EL

IDX

DTC P1705 THROTTLE POSITION SENSOR

Wiring Diagram — AT — TPS

Wiring Diagram — AT — TPS

NGAT0199

AT-TPS-01

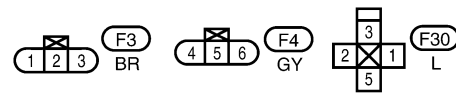
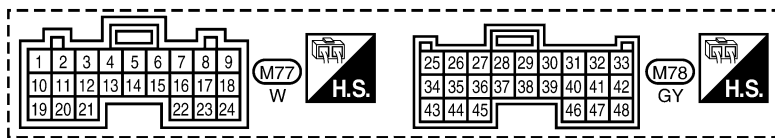
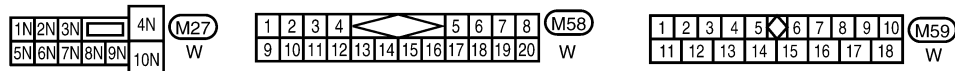
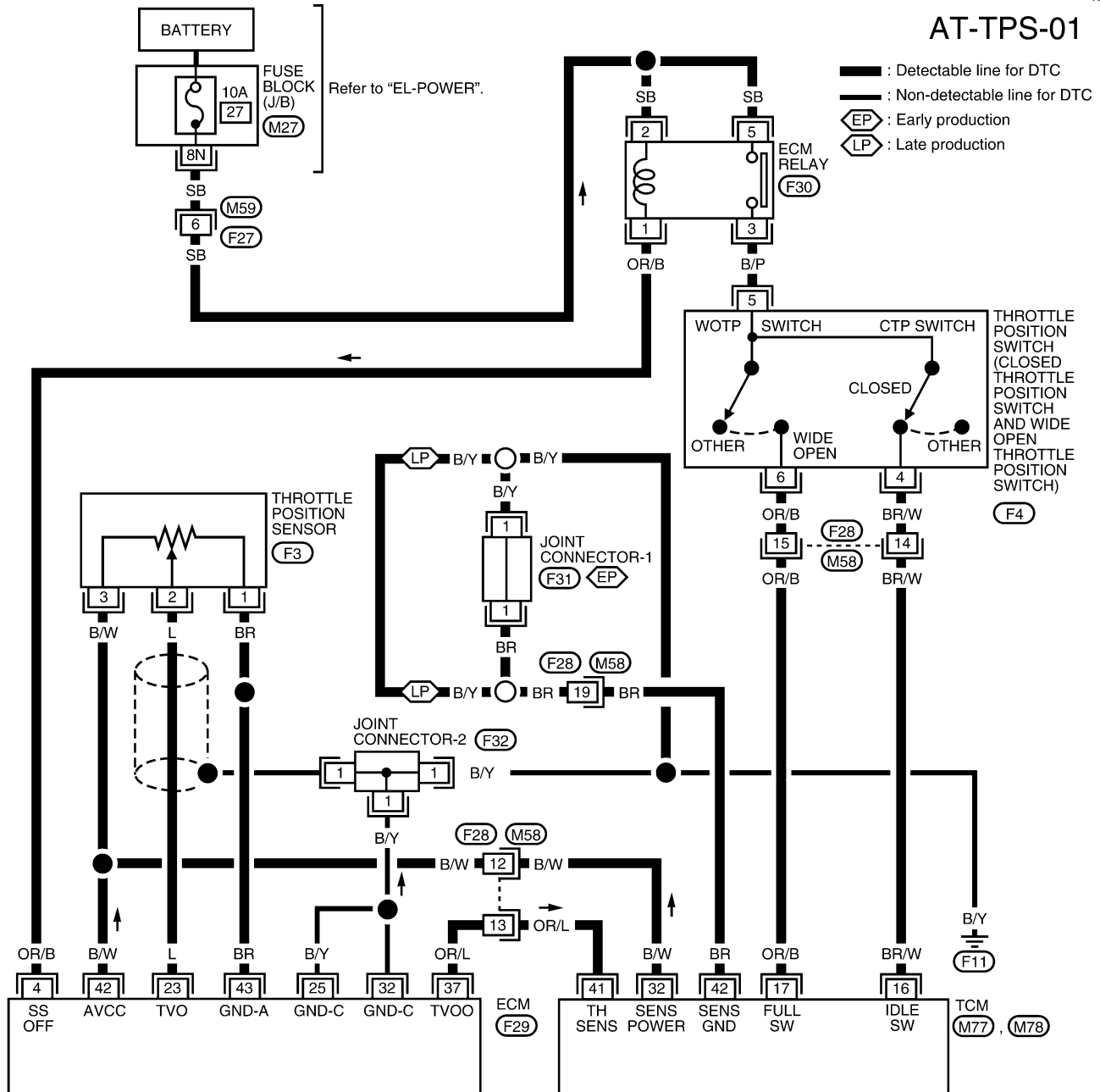

Refer to the following.
 (F32), (F31) - JOINT CONNECTOR
 (F29) - ELECTRICAL UNITS

DTC P1705 THROTTLE POSITION SENSOR

Diagnostic Procedure

Diagnostic Procedure

NGAT0067

1	CHECK DTC WITH ECM
Check P code CONSULT-II "ENGINE". Turn ignition switch "ON" and select "SELF-DIAG RESULTS" mode for "ENGINE" with CONSULT-II. Refer to EC-88 (VG33E only) or EC-1247 (VG33ER only), "MALFUNCTION INDICATOR LAMP (MIL)".	
OK or NG	
OK	▶ GO TO 2.
NG	▶ Check throttle position sensor circuit for engine control. Refer to EC-701 (VG33E only) or EC-1273 (VG33ER only), "BASIC INSPECTION".

GI

MA

EM

LC

EC

FE

CL

MT

AT

TF

PD

AX

SU

BR

ST

RS

BT

HA

SC

EL

IDX

DTC P1705 THROTTLE POSITION SENSOR

Diagnostic Procedure (Cont'd)

2 CHECK INPUT SIGNAL

With CONSULT-II

1. Turn ignition switch to ON position.
(Do not start engine.)
2. Select "TCM INPUT SIGNALS" in "DATA MONITOR" mode for "A/T" with CONSULT-II.
3. Read out the value of "THRTL POS SEN".

DATA MONITOR	
MONITORING	
VHCL/S SE-A/T	XXX km/h
VHCL/S SE-MTR	XXX km/h
THRTL POS SEN	XXX V
FLUID TEMP SE	XXX V
BATTERY VOLT	XXX V

SAT614J

Voltage:

Fully-closed throttle:
Approximately 0.5V
Fully-open throttle:
Approximately 4V

Without CONSULT-II

1. Turn ignition switch to ON position.
(Do not start engine.)
2. Check voltage between TCM connector M78 terminals 41 and 42 while accelerator pedal is depressed slowly.

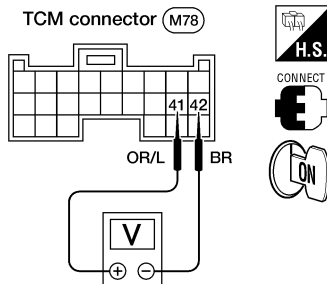

AAT474A

Voltage:

Fully-closed throttle valve:
Approximately 0.5V
Fully-open throttle valve:
Approximately 4V
(Voltage rises gradually in response to throttle position.)

OK or NG

OK (With CONSULT-II)	▶	GO TO 3.
OK (Without CONSULT-II)	▶	GO TO 4.
NG	▶	Check harness for short or open between ECM and TCM regarding throttle position sensor circuit. (Main harness)

DTC P1705 THROTTLE POSITION SENSOR

Diagnostic Procedure (Cont'd)

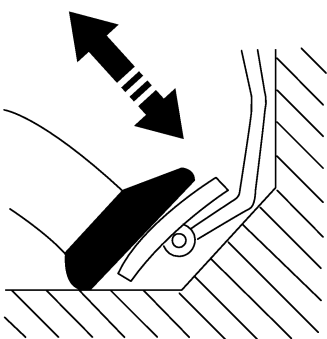
3	CHECK THROTTLE POSITION SWITCH CIRCUIT (With CONSULT-II)															
<p>Ⓜ With CONSULT-II</p> <ol style="list-style-type: none"> 1. Turn ignition switch to ON position. (Do not start engine.) 2. Select "TCM INPUT SIGNALS" in "DATA MONITOR" mode for "A/T" with CONSULT-II. 3. Read out "CLOSED THL/SW" and "W/O THRL/P-SW" depressing and releasing accelerator pedal. Check the signal of throttle position switch is indicated properly. 																
<table border="1" style="margin: auto; border-collapse: collapse;"> <thead> <tr> <th rowspan="2">Accelerator pedal condition</th> <th colspan="2">Data monitor</th> </tr> <tr> <th>CLOSED THL/SW</th> <th>W/O THRL/P-SW</th> </tr> </thead> <tbody> <tr> <td>Released</td> <td style="text-align: center;">ON</td> <td style="text-align: center;">OFF</td> </tr> <tr> <td>Fully depressed</td> <td style="text-align: center;">OFF</td> <td style="text-align: center;">ON</td> </tr> </tbody> </table>			Accelerator pedal condition	Data monitor		CLOSED THL/SW	W/O THRL/P-SW	Released	ON	OFF	Fully depressed	OFF	ON			
Accelerator pedal condition	Data monitor															
	CLOSED THL/SW	W/O THRL/P-SW														
Released	ON	OFF														
Fully depressed	OFF	ON														
<div style="display: flex; justify-content: space-around; align-items: center;">  <table border="1" style="margin: auto; border-collapse: collapse;"> <thead> <tr> <th colspan="2">DATA MONITOR</th> </tr> <tr> <th>MONITORING</th> <th></th> </tr> </thead> <tbody> <tr> <td>POWERSHIFT SW</td> <td style="text-align: center;">OFF</td> </tr> <tr> <td>CLOSED THL/SW</td> <td style="text-align: center;">OFF</td> </tr> <tr> <td>W/OTHRL/P-SW</td> <td style="text-align: center;">OFF</td> </tr> <tr> <td>HOLD SW</td> <td style="text-align: center;">OFF</td> </tr> <tr> <td>BRAKE SW</td> <td style="text-align: center;">ON</td> </tr> </tbody> </table> </div>			DATA MONITOR		MONITORING		POWERSHIFT SW	OFF	CLOSED THL/SW	OFF	W/OTHRL/P-SW	OFF	HOLD SW	OFF	BRAKE SW	ON
DATA MONITOR																
MONITORING																
POWERSHIFT SW	OFF															
CLOSED THL/SW	OFF															
W/OTHRL/P-SW	OFF															
HOLD SW	OFF															
BRAKE SW	ON															
<p>MTBL0011</p> <p>SAT646J</p>																
OK or NG																
OK	▶	GO TO 5.														
NG	▶	<p>Check the following items:</p> <ul style="list-style-type: none"> ● Throttle position switch Refer to "Component Inspection", AT-187. ● Harness for short or open between ignition switch and throttle position switch (Main harness) ● Harness for short or open between throttle position switch and TCM (Main harness) 														

GI
 MA
 EM
 LC
 EC
 FE
 CL
 MT
AT
 TF
 PD
 AX
 SU
 BR
 ST
 RS
 BT
 HA
 SC
 EL
 IDX

DTC P1705 THROTTLE POSITION SENSOR

Diagnostic Procedure (Cont'd)

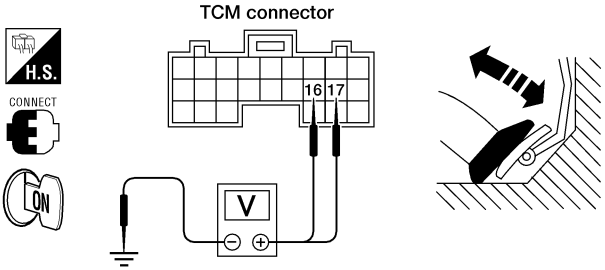
4	CHECK THROTTLE POSITION SWITCH CIRCUIT (Without CONSULT-II)												
<p>⊗ Without CONSULT-II</p> <ol style="list-style-type: none"> Turn ignition switch to ON position. (Do not start engine.) Check voltage between TCM connector M77 terminals [16 (BR/W), 17 (OR/B)] and ground while depressing, and releasing accelerator pedal slowly. (after warming up engine) 													
													
<table border="1" style="margin-left: auto;"> <thead> <tr> <th rowspan="2">Accelerator pedal condition</th> <th colspan="2">Voltage</th> </tr> <tr> <th>Terminal No. 16</th> <th>Terminal No. 17</th> </tr> </thead> <tbody> <tr> <td>Released</td> <td>Battery voltage</td> <td>0V</td> </tr> <tr> <td>Fully Depressed</td> <td>0V</td> <td>Battery voltage</td> </tr> </tbody> </table>			Accelerator pedal condition	Voltage		Terminal No. 16	Terminal No. 17	Released	Battery voltage	0V	Fully Depressed	0V	Battery voltage
Accelerator pedal condition	Voltage												
	Terminal No. 16	Terminal No. 17											
Released	Battery voltage	0V											
Fully Depressed	0V	Battery voltage											
LAT329													
OK or NG													
OK	▶	GO TO 5.											
NG	▶	<p>Check the following items:</p> <ul style="list-style-type: none"> ● Throttle position switch Refer to "Component Inspection", AT-187. ● Harness for short or open between ignition switch and throttle position switch (Main harness) ● Harness for short or open between throttle position switch and TCM (Main harness) 											

5	CHECK DTC	
<p>Perform Diagnostic Trouble Code (DTC) confirmation procedure. Refer to "DIAGNOSTIC TROUBLE CODE (DTC) CONFIRMATION PROCEDURE", AT-180.</p>		
OK or NG		
OK	▶	INSPECTION END
NG	▶	<ol style="list-style-type: none"> Perform TCM input/output signal inspection. If NG, recheck TCM pin terminals for damage or loose connection with harness connector.

DTC P1705 THROTTLE POSITION SENSOR

Component Inspection

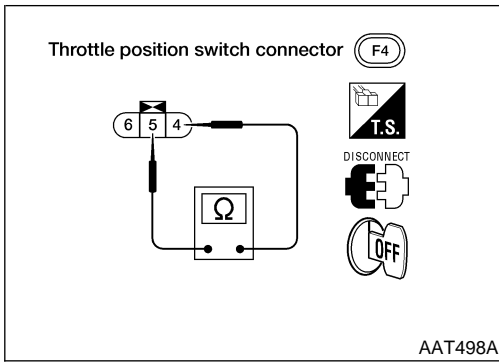

Component Inspection

THROTTLE POSITION SWITCH

=NGAT0205

NGAT0205S01

NGAT0205S0101

Closed Throttle Position Switch (Idle position)

- Check continuity between terminals 4 and 5.

Accelerator pedal condition	Continuity
Released	Yes
Depressed	No

- To adjust closed throttle position switch, refer to **EC-701** (VG33E only) or **EC-1273** (VG33ER only), "Basic Inspection".

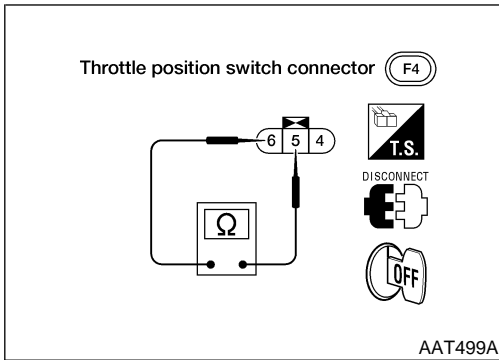

Wide Open Throttle Position Switch

NGAT0205S0102

- Check continuity between terminals 5 and 6.

Accelerator pedal condition	Continuity
Released	No
Depressed	Yes

GI
MA
EM
LC
EC
FE
CL
MT
AT
TF
PD
AX
SU
BR
ST
RS
BT
HA
SC
EL
IDX

DTC P1760 OVERRUN CLUTCH SOLENOID VALVE

Description

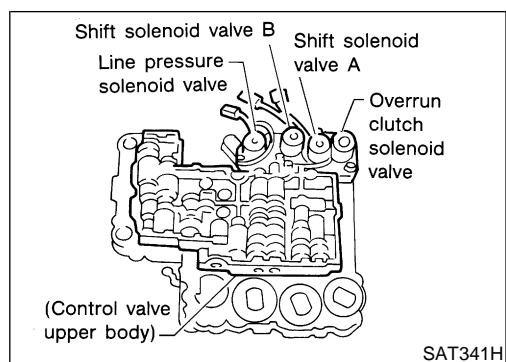

Description

The overrun clutch solenoid valve is activated by the TCM^{NGAT0068} in response to signals sent from the PNP switch, overdrive control switch, vehicle speed and throttle position sensors. The overrun clutch operation will then be controlled.

TCM TERMINALS AND REFERENCE VALUE

NGAT0068S02

Remarks: Specification data are reference values.

Terminal No.	Wire color	Item	Condition	Judgement standard (Approx.)
20	L/B	Overrun clutch solenoid valve	 When overrun clutch solenoid valve operates.	Battery voltage
			When overrun clutch solenoid valve does not operate.	0V

ON BOARD DIAGNOSIS LOGIC

NGAT0068S03

Diagnostic trouble code	Malfunction is detected when ...	Check item (Possible cause)
(P) : O/R CLTCH SOL/CIRC (P) : P1760	TCM detects an improper voltage drop when it tries to operate the solenoid valve.	<ul style="list-style-type: none"> ● Harness or connectors (The solenoid circuit is open or shorted.) ● Overrun clutch solenoid valve

DTC P1760 OVERRUN CLUTCH SOLENOID VALVE

Description (Cont'd)

SELECT SYSTEM
A/T
ENGINE

SAT014K

SELECT DIAG MODE
WORK SUPPORT
SELF-DIAG RESULTS
DATA MONITOR
DATA MONITOR (SPEC)
ACTIVE TEST
DTC & SRT CONFIRMATION

SEF949Y

DIAGNOSTIC TROUBLE CODE (DTC) CONFIRMATION PROCEDURE

=NGAT0068S01

CAUTION:

Always drive vehicle at a safe speed.

NOTE:

If "DIAGNOSTIC TROUBLE CODE CONFIRMATION PROCEDURE" has been previously conducted, always turn ignition switch OFF and wait at least 5 seconds before conducting the next test.

TESTING CONDITION:

Always drive vehicle on a level road to improve accuracy of test.

After the repair, perform the following procedure to confirm the malfunction is eliminated.

Ⓜ With CONSULT-II

- 1) Turn ignition switch ON and select "DATA MONITOR" mode for "ENGINE" with CONSULT-II.
- 2) Start engine.
- 3) Accelerate vehicle to a speed of more than 10 km/h (6MPH) in D position (O/D ON).
- 4) Release accelerator pedal completely in D position (O/D OFF).

Ⓜ With GST

Follow the procedure "With CONSULT-II".

GI

MA

EM

LC

EC

FE

CL

MT

AT

TF

PD

AX

SU

BR

ST

RS

BT

HA

SC

EL

IDX

DTC P1760 OVERRUN CLUTCH SOLENOID VALVE

Wiring Diagram — AT — OVRCSV

Wiring Diagram — AT — OVRCSV

NGAT0200

AT-OVRCSV-01

: Detectable line for DTC
 : Non-detectable line for DTC

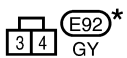
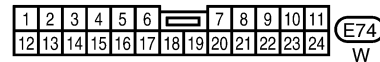
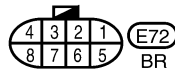
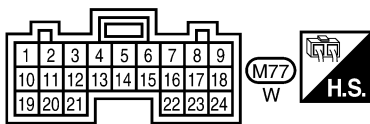
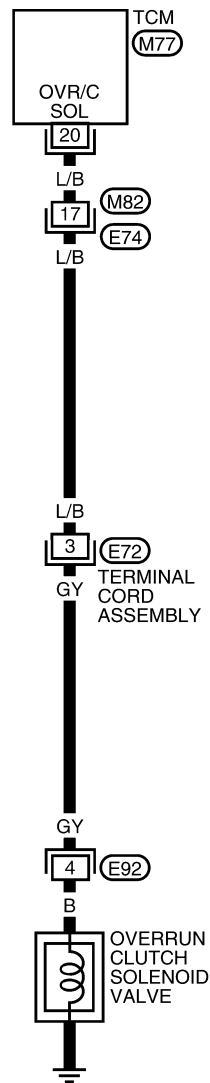

* : This connector is not shown in "HARNESS LAYOUT" of EL section.

LAT508

DTC P1760 OVERRUN CLUTCH SOLENOID VALVE

Diagnostic Procedure

Diagnostic Procedure

NGAT0069

1	CHECK GROUND CIRCUIT	
<p>1. Turn ignition switch to OFF position. 2. Disconnect terminal cord assembly connector in engine compartment. 3. Check resistance between terminal cord assembly connector E72 terminal 3 and ground.</p> <div style="text-align: center;"> <p>Terminal cord assembly connector (E72)</p> <p>Ω</p> <p>DISCONNECT</p> </div> <p style="text-align: right;">AAT500A</p> <p style="text-align: center;">Is resistance approx. 20 - 40Ω?</p>		
Yes	▶	GO TO 2.
No	▶	<p>1. Remove control valve assembly. Refer to "REMOVAL", AT-267.</p> <p>2. Check the following items:</p> <ul style="list-style-type: none"> ● Overrun clutch solenoid valve Refer to "Component Inspection", AT-192. ● Harness of terminal cord assembly for short or open

2	CHECK POWER SOURCE CIRCUIT	
<p>1. Turn ignition switch to OFF position. 2. Disconnect TCM harness connector. 3. Check resistance between terminal cord assembly connector E72 terminal 3 and TCM harness connector M77 terminal 20. Refer to "Wiring Diagram — AT — OVRCSV —", AT-190. If OK, check harness for short to ground and short to power.</p> <p style="text-align: center;">Is resistance approx 0Ω?</p>		
Yes	▶	GO TO 3.
No	▶	Repair open circuit or short to ground or short to power in harness or connectors.

3	CHECK DTC	
<p>Perform Diagnostic Trouble Code (DTC) confirmation procedure. Refer to "DIAGNOSTIC TROUBLE CODE (DTC) CONFIRMATION PROCEDURE", AT-189.</p> <p style="text-align: center;">OK or NG</p>		
OK	▶	INSPECTION END
NG	▶	<p>1. Perform TCM input/output signal inspection. 2. If NG, recheck TCM pin terminals for damage or loose connection with harness connector.</p>

GI
MA
EM
LC
EC
FE
CL
MT
AT
TF
PD
AX
SU
BR
ST
RS
BT
HA
SC
EL
IDX

DTC P1760 OVERRUN CLUTCH SOLENOID VALVE

Component Inspection

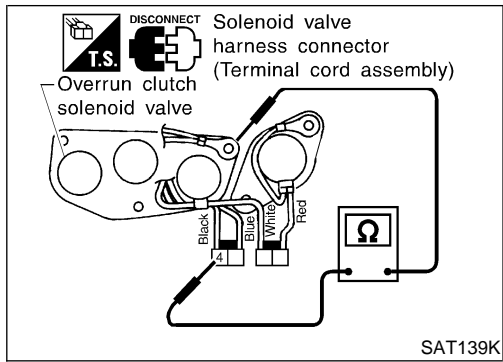

Component Inspection OVERRUN CLUTCH SOLENOID VALVE

=NGAT0070

NGAT0070S01

- For removal, refer to “REMOVAL”, AT-267.

Resistance Check

NGAT0070S0101

- Check resistance between terminal 4 and ground.

Solenoid valve	Terminal No.		Resistance (Approx.)
Overrun clutch solenoid valve	4	Ground	20 - 40Ω

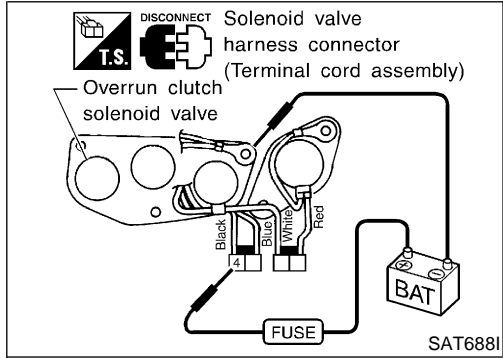

Operation Check

NGAT0070S0102

- Check solenoid valve by listening for its operating sound while applying battery voltage to the terminal 4 and ground.

DTC BATT/FLUID TEMP SEN (A/T FLUID TEMP SENSOR CIRCUIT AND TCM POWER SOURCE)

Description

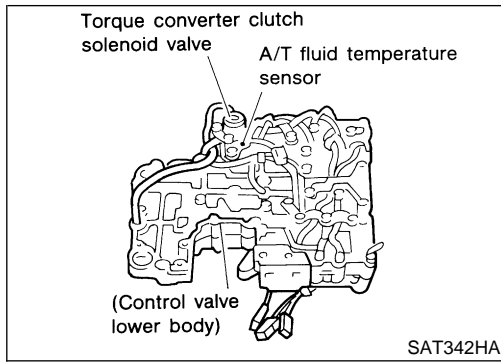

Description

The A/T fluid temperature sensor detects the A/T fluid temperature and sends a signal to the TCM. NGAT0172

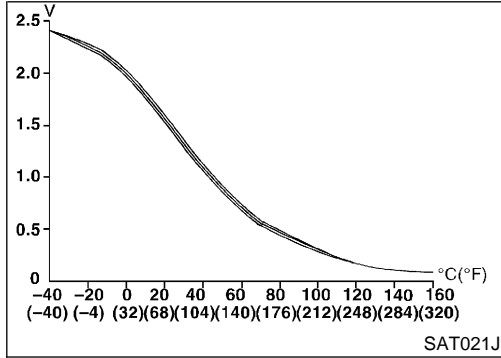

CONSULT-II REFERENCE VALUE IN DATA MONITOR MODE

NGAT0172S02

Remarks: Specification data are reference values.

Monitor item	Condition	Specification (Approx.)	
A/T fluid temperature sensor	Cold [20°C (68°F)]	1.5V	2.5 kΩ
	Hot [80°C (176°F)]	0.5V	0.3 kΩ

TCM TERMINALS AND REFERENCE VALUE

NGAT0172S03

Remarks: Specification data are reference values.

Terminal No.	Wire color	Item	Condition	Judgement standard (Approx.)
10	W/R	Power source	When turning ignition switch to ON.	Battery voltage
			When turning ignition switch to OFF.	0V
19	W/R	Power source (same as No. 10)	Same as No. 10	
28	R/Y	Power source (Memory back-up)	When turning ignition switch to OFF.	Battery voltage
			When turning ignition switch to ON.	Battery voltage
42	BR	Throttle position sensor (Ground)	—	0V
47	R/B	A/T fluid temperature sensor	When ATF temperature is 20°C (68°F).	1.5V
			When ATF temperature is 80°C (176°F).	0.5V

DTC BATT/FLUID TEMP SEN (A/T FLUID TEMP SENSOR CIRCUIT AND TCM POWER SOURCE)

Description (Cont'd)

ON BOARD DIAGNOSIS LOGIC

NGAT017ZS04

Diagnostic trouble code	Malfunction is detected when ...	Check item (Possible cause)
(P) : BATT/FLUID TEMP SEN (X) : 8th judgement flicker	TCM receives an excessively low or high voltage from the sensor.	<ul style="list-style-type: none"> • Harness or connectors (The sensor circuit is open or shorted.) • A/T fluid temperature sensor

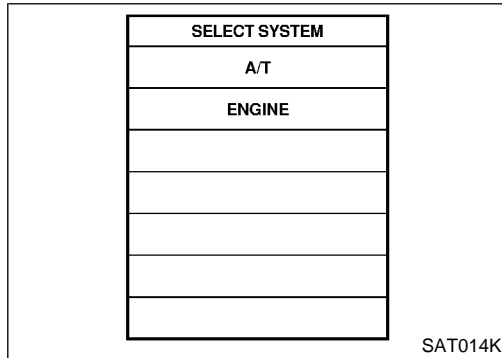

DIAGNOSTIC TROUBLE CODE (DTC) CONFIRMATION PROCEDURE

NGAT017ZS01

After the repair, perform the following procedure to confirm the malfunction is eliminated.

(P) With CONSULT-II

- 1) Start engine.
- 2) Select "DATA MONITOR" mode for "A/T" with CONSULT-II.
- 3) Drive vehicle under the following conditions:
Selector lever in D position, vehicle speed higher than 20 km/h (12 MPH).

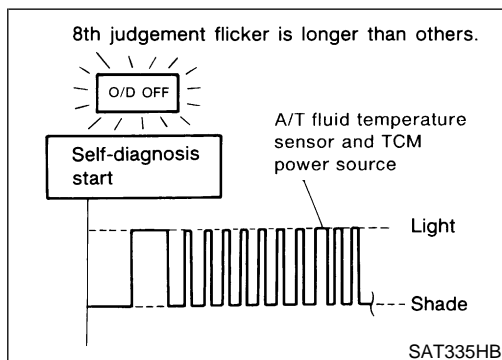
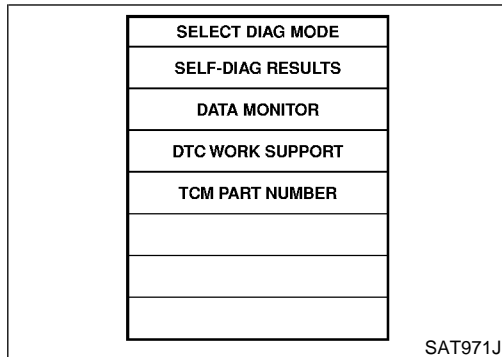

(X) Without CONSULT-II

- 1) Start engine.
- 2) Drive vehicle under the following conditions:
Selector lever in D position, vehicle speed higher than 20 km/h (12 MPH).
- 3) Perform self-diagnosis.
Refer to "TCM SELF-DIAGNOSTIC PROCEDURE (NO TOOLS)", AT-47.

DTC BATT/FLUID TEMP SEN (A/T FLUID TEMP SENSOR CIRCUIT AND TCM POWER SOURCE)

Diagnostic Procedure

Diagnostic Procedure

NGAT0173

1	CHECK TCM POWER SOURCE	
		<p>1. Turn ignition switch to ON position. (Do not start engine.)</p> <p>2. Check voltage between TCM terminals (10, 19, 28) and ground.</p> <div style="text-align: center;"> </div> <p>Voltage: Battery voltage</p> <p>3. Turn ignition switch to OFF position.</p> <p>4. Check voltage between TCM terminal 28 and ground.</p> <p>Voltage: Battery voltage</p> <p style="text-align: right;">AAT476A</p>
		OK or NG
OK	▶	GO TO 2.
NG	▶	<p>Check the following items:</p> <ul style="list-style-type: none"> ● Harness for short or open between ignition switch and TCM terminals (10, 19 and 28) (Main harness) ● Ignition switch and fuse <p>Refer to EL-10, "POWER SUPPLY ROUTING".</p>

2	CHECK A/T FLUID TEMPERATURE SENSOR WITH TERMINAL CORD ASSEMBLY	
		<p>1. Turn ignition switch to OFF position.</p> <p>2. Disconnect terminal cord assembly connector in engine compartment.</p> <p>3. Check resistance between terminal cord assembly connector E72 terminals 6 and 7 when A/T is cold [20°C (68°F)].</p> <div style="text-align: center;"> </div> <p style="text-align: right;">AAT502A</p>
		Is resistance approx. 2.5kΩ?
Yes	▶	GO TO 3.
No	▶	<p>1. Remove oil pan.</p> <p>2. Check the following items:</p> <ul style="list-style-type: none"> ● A/T fluid temperature sensor ● Refer to "Component Inspection", AT-198. ● Harness of terminal cord assembly for short or open

DTC BATT/FLUID TEMP SEN (A/T FLUID TEMP SENSOR CIRCUIT AND TCM POWER SOURCE)

Diagnostic Procedure (Cont'd)

3	CHECK INPUT SIGNAL OF A/T FLUID TEMPERATURE SENSOR														
<p>Ⓜ With CONSULT</p> <ol style="list-style-type: none"> Start engine. Select "TCM INPUT SIGNALS" in "DATA MONITOR" mode for "A/T" with CONSULT. Read out the value of "FLUID TEMP SE". 															
<table border="1" style="margin: auto;"> <thead> <tr> <th colspan="2">DATA MONITOR</th> </tr> <tr> <th>MONITORING</th> <th></th> </tr> </thead> <tbody> <tr> <td>VHCL/S SE-A/T</td> <td>XXX km/h</td> </tr> <tr> <td>VHCL/S SE-MTR</td> <td>XXX km/h</td> </tr> <tr> <td>THRTL POS SEN</td> <td>XXX V</td> </tr> <tr> <td>FLUID TEMP SE</td> <td>XXX V</td> </tr> <tr> <td>BATTERY VOLT</td> <td>XXX V</td> </tr> </tbody> </table>		DATA MONITOR		MONITORING		VHCL/S SE-A/T	XXX km/h	VHCL/S SE-MTR	XXX km/h	THRTL POS SEN	XXX V	FLUID TEMP SE	XXX V	BATTERY VOLT	XXX V
DATA MONITOR															
MONITORING															
VHCL/S SE-A/T	XXX km/h														
VHCL/S SE-MTR	XXX km/h														
THRTL POS SEN	XXX V														
FLUID TEMP SE	XXX V														
BATTERY VOLT	XXX V														
SAT614J															
<p>Voltage: Cold [20°C (68°F)] → Hot [80°C (176°F)]: Approximately 1.5V → 0.5V</p>															
<p>ⓧ Without CONSULT</p> <ol style="list-style-type: none"> Start engine. Check voltage between TCM connector M78 terminal 47 and ground while warming up A/T. 															
AAT503A															
<p>Voltage: Cold [20°C (68°F)] → Hot [80°C (176°F)]: Approximately 1.5V → 0.5V</p>															
OK or NG															
OK	▶ GO TO 4.														
NG	▶ Check the following item: ● Harness for short or open between TCM and terminal cord assembly (Main harness)														

4	CHECK DTC
Perform Diagnostic Trouble Code (DTC) confirmation Procedure, AT-194.	
OK or NG	
OK	▶ INSPECTION END
NG	▶ <ul style="list-style-type: none"> Perform TCM input/output signal inspection. If NG, recheck TCM pin terminals for damage or loose connection with harness connector.

GI
MA
EM
LC
EC
FE
CL
MT
AT
TF
PD
AX
SU
BR
ST
RS
BT
HA
SC
EL
IDX

DTC BATT/FLUID TEMP SEN (A/T FLUID TEMP SENSOR CIRCUIT AND TCM POWER SOURCE)

Component Inspection

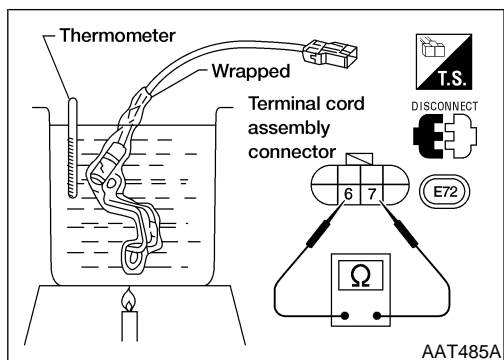

Component Inspection

A/T FLUID TEMPERATURE SENSOR

NGAT0174

NGAT0174S01

- For removal, refer to "REMOVAL", AT-267.
- Check resistance between terminals 6 and 7 while changing temperature as shown at left.

Temperature °C (°F)	Resistance (Approx.)
20 (68)	2.5 kΩ
80 (176)	0.3 kΩ

DTC VEHICLE SPEED SENSOR-MTR

Description

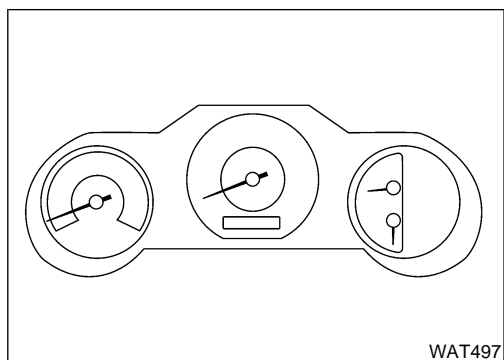

Description

The vehicle speed sensor-MTR is built into the unified meter control unit. The sensor functions as an auxiliary device to the revolution sensor when it is malfunctioning. The TCM will then use a signal sent from the vehicle speed sensor-MTR.

NGAT0071

GI

MA

EM

LC

TCM TERMINALS AND REFERENCE VALUE

NGAT0071S02

Remarks: Specification data are reference values.

Terminal No.	Wire color	Item	Condition	Judgement standard (Approx.)
40	G/B	Vehicle speed sensor	 When moving vehicle at 2 to 3 km/h (1 to 2 MPH) for 1 m (3 ft) or more.	Voltage varies between less than 1V and more than 4.5V

EC



FE

CL

MT

ON BOARD DIAGNOSIS LOGIC

NGAT0071S03

Diagnostic trouble code	Malfunction is detected when ...	Check item (Possible cause)
 : VHCL SPEED SEN-MTR	TCM does not receive the proper voltage signal from the sensor.	<ul style="list-style-type: none"> • Harness or connectors (The sensor circuit is open or shorted.) • Vehicle speed sensor
 : 2nd judgement flicker		

AT

TF

PD

AX

SU

BR

ST

RS

BT

HA

SC

EL

IDX

DTC VEHICLE SPEED SENSOR-MTR

Description (Cont'd)

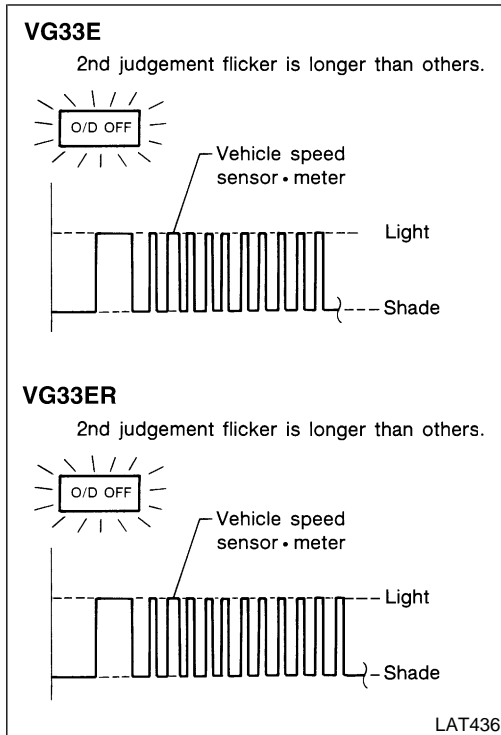
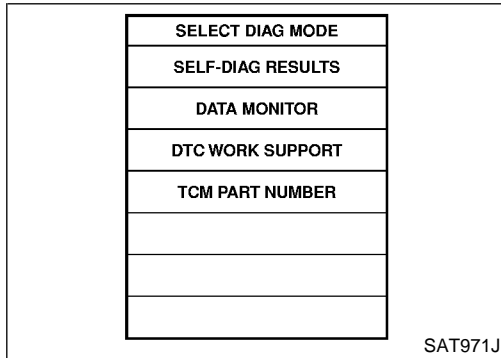
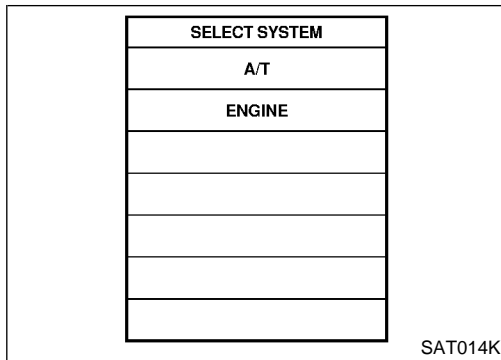

DIAGNOSTIC TROUBLE CODE (DTC) CONFIRMATION PROCEDURE

=NGAT0071S01

CAUTION:

- Always drive vehicle at a safe speed.
- If conducting this “DTC CONFIRMATION PROCEDURE” again, always turn ignition switch OFF and wait at least 5 seconds before continuing.

After the repair, perform the following procedure to confirm the malfunction is eliminated.

④ With CONSULT-II

- 1) Turn ignition switch ON and select “DATA MONITOR” mode for “A/T” with CONSULT-II.
- 2) Start engine and accelerate vehicle from 0 to 25 km/h (0 to 6 MPH).

⊗ Without CONSULT-II

- 1) Start engine.
- 2) Drive vehicle under the following conditions:
Selector lever in D position and vehicle speed higher than 25 km/h (16 MPH).
- 3) Perform self-diagnosis.
Refer to “TCM SELF-DIAGNOSTIC PROCEDURE (NO TOOLS)”, AT-47.

DTC VEHICLE SPEED SENSOR-MTR

Wiring Diagram — AT — VSSMTR

Wiring Diagram — AT — VSSMTR

NGAT0202

AT-VSSMTR-01

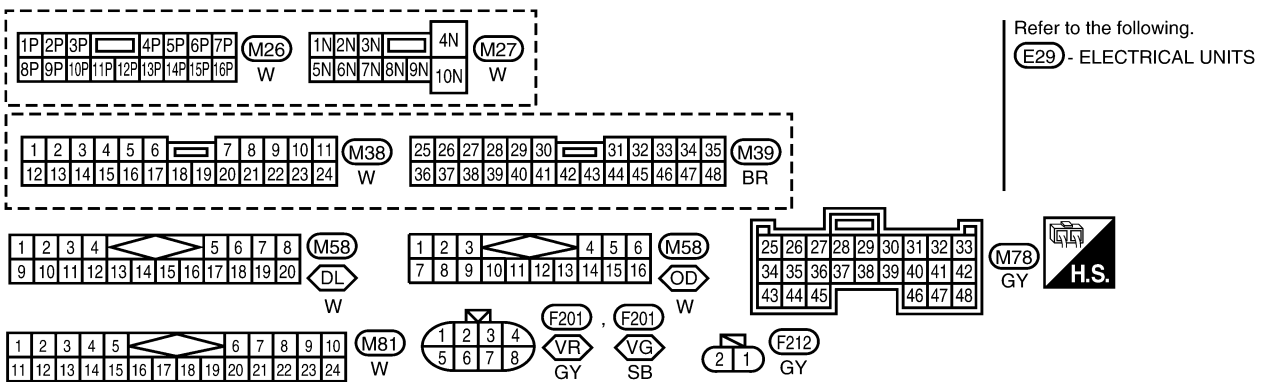
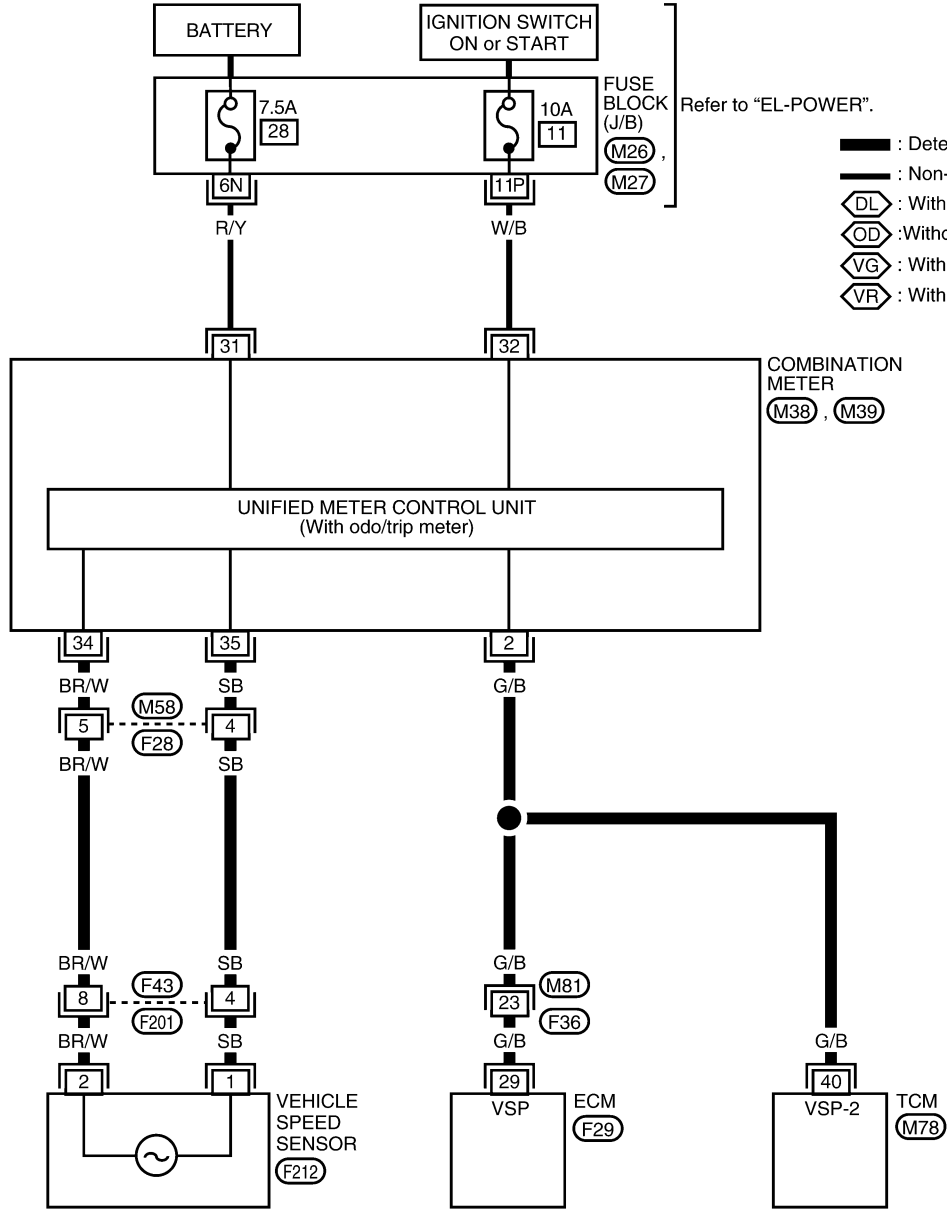



GI
 MA
 EM
 LC
 EC
 FE
 CL
 MT
AT
 TF
 PD
 AX
 SU
 BR
 ST
 RS
 BT
 HA
 SC
 EL
 IDX

DTC VEHICLE SPEED SENSOR-MTR

Diagnostic Procedure

Diagnostic Procedure

NGAT0072

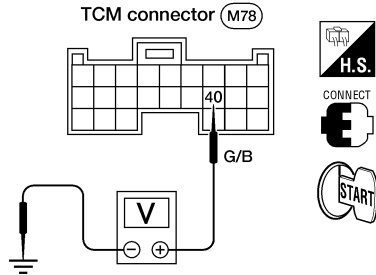
1	CHECK INPUT SIGNAL.														
<p> With CONSULT-II</p> <ol style="list-style-type: none"> Start engine. Select "TCM INPUT SIGNALS" in "DATA MONITOR" mode for "A/T" with CONSULT-II. Read out the value of "VHCL/S SE-MTR" while driving. Check the value changes according to driving speed. 															
<table border="1"> <thead> <tr> <th colspan="2">DATA MONITOR</th> </tr> <tr> <th>MONITORING</th> <th></th> </tr> </thead> <tbody> <tr> <td>VHCL/S SE-A/T</td> <td>XXX km/h</td> </tr> <tr> <td>VHCL/S SE-MTR</td> <td>XXX km/h</td> </tr> <tr> <td>THRTL POS SEN</td> <td>XXX V</td> </tr> <tr> <td>FLUID TEMP SE</td> <td>XXX V</td> </tr> <tr> <td>BATTERY VOLT</td> <td>XXX V</td> </tr> </tbody> </table>		DATA MONITOR		MONITORING		VHCL/S SE-A/T	XXX km/h	VHCL/S SE-MTR	XXX km/h	THRTL POS SEN	XXX V	FLUID TEMP SE	XXX V	BATTERY VOLT	XXX V
DATA MONITOR															
MONITORING															
VHCL/S SE-A/T	XXX km/h														
VHCL/S SE-MTR	XXX km/h														
THRTL POS SEN	XXX V														
FLUID TEMP SE	XXX V														
BATTERY VOLT	XXX V														
SAT614J															
<p> Without CONSULT-II</p> <ol style="list-style-type: none"> Start engine. Check voltage between TCM connector M78 terminal 40 and ground while driving at 2 to 3 km/h (1 to 2 MPH) for 1 m (3 ft) or more. 															
															
AAT504A															
Does battery voltage vary between less than 1V and more than 4.5V?															
Yes	▶ GO TO 2.														
No	▶ Check the following items: <ul style="list-style-type: none"> Vehicle speed sensor and ground circuit for vehicle speed sensor Refer to EL-75, "METERS AND GAUGES". Harness for short or open between TCM and vehicle speed sensor (Main harness) 														

2	CHECK DTC
Perform Diagnostic Trouble Code (DTC) confirmation procedure, AT-200.	
OK or NG	
OK	▶ INSPECTION END
NG	▶ <ol style="list-style-type: none"> Perform TCM input/output signal inspection. If NG, recheck TCM pin terminals for damage or loose connection with harness connector.

DTC TURBINE REVOLUTION SENSOR (VG33ER ONLY)

Description

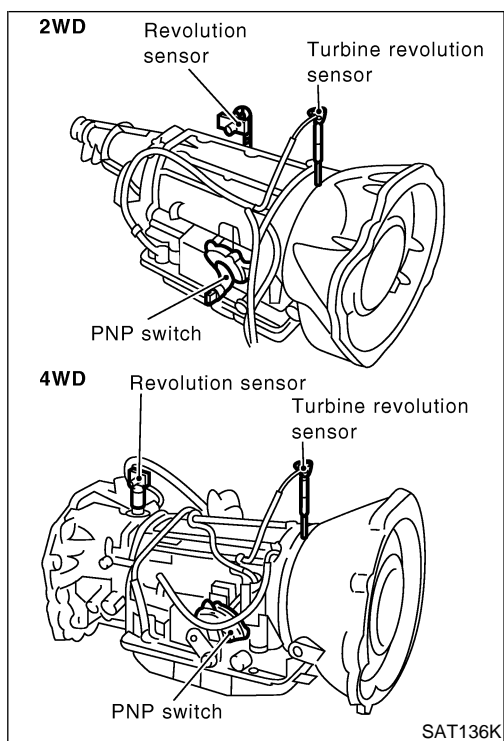

Description

The turbine revolution sensor detects input shaft rpm (revolutions per minute). It is located on the input side of the automatic transmission. The vehicle speed sensor A/T (Revolution sensor) is located on the output side of the automatic transmission. With the two sensors, input and output shaft rpms are accurately detected. The result is optimal shift timing during deceleration and improved shifting.





NGAT0215

GI
MA
EM
LC
EC
FE
CL
MT

TCM TERMINALS AND REFERENCE VALUE

NGAT0215S01

Remarks: Specification data are reference values.

Terminal No.	Wire color	Item	Condition	Judgement standard (Approx.)
38	Y	Turbine revolution sensor (Measure in AC range)	  When engine is running at 1,000 rpm	1.2V Voltage rises gradually in response to engine speed.
42	BR	Throttle position sensor (Ground)	  —	0V

AT

TF

PD



AX

SU

BR

ON BOARD DIAGNOSIS LOGIC

NGAT0215S02

Diagnostic trouble code	Malfunction is detected when ...	Check item (Possible cause)
 : TURBINE REV  : 10th judgement flicker	TCM does not receive the proper voltage signal from the sensor.	<ul style="list-style-type: none"> • Harness or connectors (The sensor circuit is open or shorted.) • Turbine revolution sensor

ST

RS

BT

HA

SC

EL

IDX

DTC TURBINE REVOLUTION SENSOR (VG33ER ONLY)

Description (Cont'd)

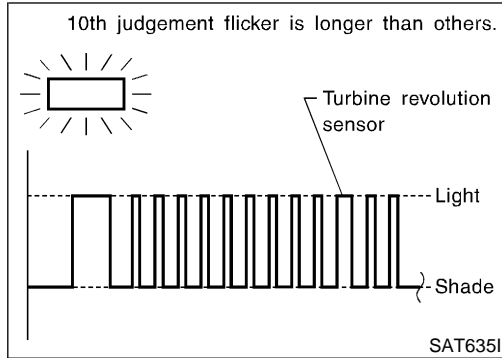
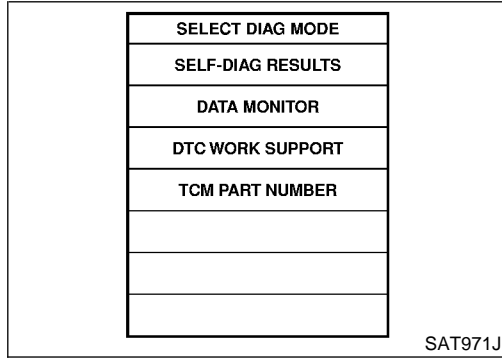
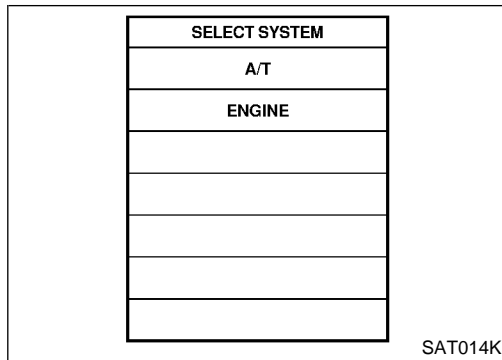

DIAGNOSTIC TROUBLE CODE (DTC) CONFIRMATION PROCEDURE

NGAT0215S03

CAUTION:

- Always drive vehicle at a safe speed.
- If conducting this “DTC CONFIRMATION PROCEDURE” again, always turn ignition switch “OFF” and wait at least 5 seconds before continuing.

After the repair, perform the following procedure to confirm the malfunction is eliminated.

With CONSULT-II

- 1) Start engine.
- 2) Select “DATA MONITOR” mode for “A/T” with CONSULT-II.
- 3) Drive vehicle under the following conditions:
Selector lever in “D”, vehicle speed higher than 40 km/h (25 MPH), engine speed higher than 1,500 rpm, throttle opening greater than 1.0/8 of the full throttle position and driving for more than 5 seconds.

No Tools

- 1) Start engine.
- 2) Drive vehicle under the following conditions:
Selector lever in “D”, vehicle speed higher than 40 km/h (25 MPH), engine speed higher than 1,500 rpm, throttle opening greater than 1/8 of the full throttle position and driving for more than 5 seconds.
- 3) Perform self-diagnosis.
Refer to “TCM SELF-DIAGNOSTIC PROCEDURE (No Tools)”, AT-47.

DTC TURBINE REVOLUTION SENSOR (VG33ER ONLY)

Wiring Diagram — AT — TRSA/T

Wiring Diagram — AT — TRSA/T

NGAT0216

AT-TRSA/T-01

- : Detectable line for DTC
- : Non-detectable line for DTC
- : Early production
- : Late production

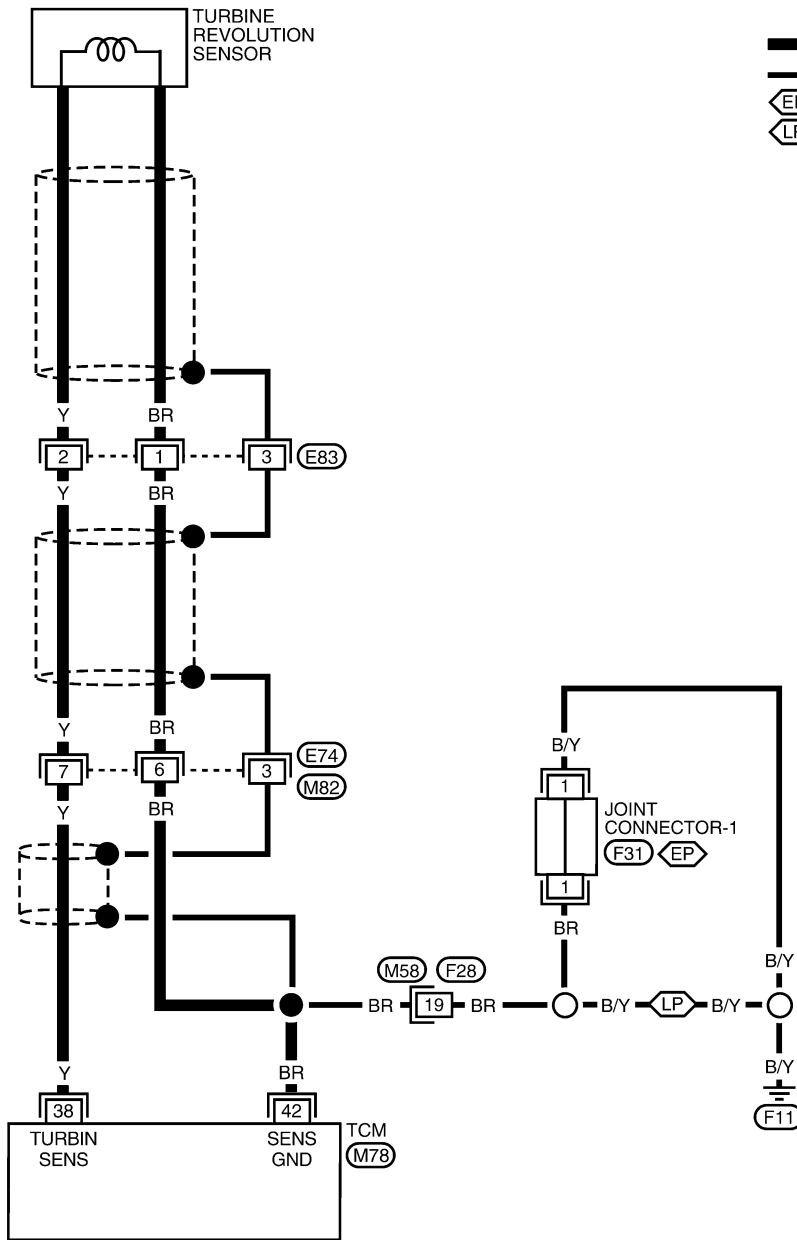

GI
MA
EM
LC
EC
FE
CL
MT
AT
TF
PD
AX
SU
BR
ST
RS
BT
HA
SC
EL
IDX

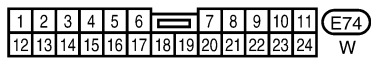
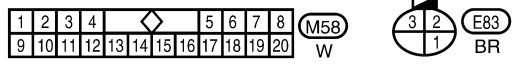
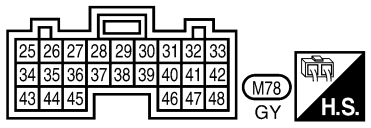

Refer to the following.
 - JOINT CONNECTOR

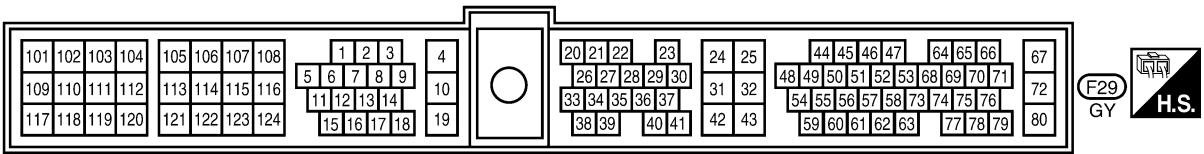



WAT546

DTC TURBINE REVOLUTION SENSOR (VG33ER ONLY)

Diagnostic Procedure

Diagnostic Procedure

NGAT0217

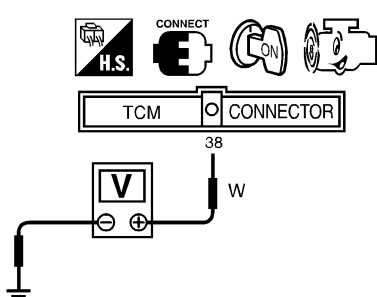
1	CHECK INPUT SIGNAL																
<p> With CONSULT-II</p> <ol style="list-style-type: none"> Start engine. Select "TCM INPUT SIGNALS" in "DATA MONITOR" mode for "A/T" with CONSULT-II. Read out the value of "TURBINE REV". Check the value changes according to engine speed. 																	
<table border="1"> <thead> <tr> <th colspan="2">DATA MONITOR</th> </tr> <tr> <th>MONITORING</th> <th></th> </tr> </thead> <tbody> <tr> <td>ENGINE SPEED</td> <td>XXX rpm</td> </tr> <tr> <td>TURBINE REV</td> <td>XXX rpm</td> </tr> <tr> <td>OVERDRIVE SW</td> <td>ON</td> </tr> <tr> <td>PN POSI SW</td> <td>OFF</td> </tr> <tr> <td>R POSITION SW</td> <td>OFF</td> </tr> </tbody> </table>				DATA MONITOR		MONITORING		ENGINE SPEED	XXX rpm	TURBINE REV	XXX rpm	OVERDRIVE SW	ON	PN POSI SW	OFF	R POSITION SW	OFF
DATA MONITOR																	
MONITORING																	
ENGINE SPEED	XXX rpm																
TURBINE REV	XXX rpm																
OVERDRIVE SW	ON																
PN POSI SW	OFF																
R POSITION SW	OFF																
SAT740J																	
<p> Without CONSULT-II</p> <ol style="list-style-type: none"> Start engine. Check voltage between TCM terminal 38 and ground. (Measure in AC range.) 																	
																	
<p>Approximately 1.2V (Voltage rises gradually in response to engine speed.)</p>																	
SAT140K																	
OK or NG																	
OK	▶	GO TO 3.															
NG	▶	GO TO 2.															

2	DETECT MALFUNCTIONING ITEM	Check harness for short or open between TCM and turbine revolution sensor.	
OK or NG			
OK	▶	GO TO 3.	
NG	▶	Repair or replace damaged parts.	

3	CHECK DTC	Perform "DIAGNOSTIC TROUBLE CODE (DTC) CONFIRMATION PROCEDURE", AT-204.	
OK or NG			
OK	▶	INSPECTION END	
NG	▶	GO TO 4.	

DTC TURBINE REVOLUTION SENSOR (VG33ER ONLY)

Diagnostic Procedure (Cont'd)

4	CHECK TCM INSPECTION	
1. Perform TCM input/output signal inspection. 2. If NG, recheck TCM pin terminal for damage or loose connection with harness connector. <p style="text-align: center;">OK or NG</p>		
OK	▶	INSPECTION END
NG	▶	Repair or replace damaged parts.

GI
MA
EM
LC
EC
FE
CL
MT
AT
TF
PD
AX
SU
BR
ST
RS
BT
HA
SC
EL
IDX

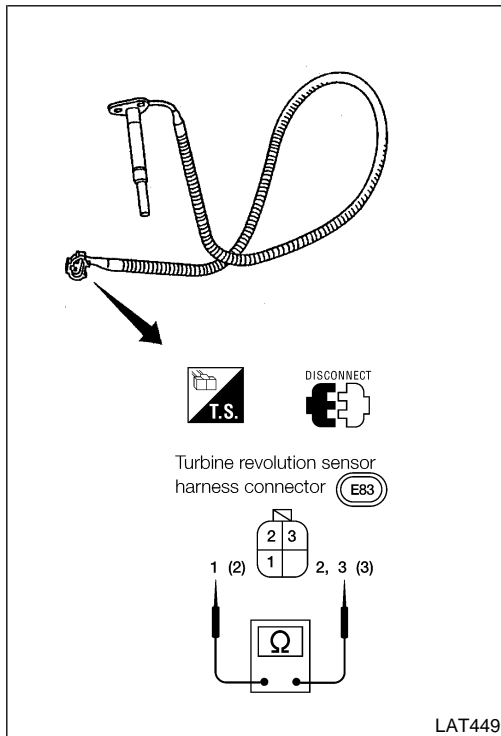

Component Inspection TURBINE REVOLUTION SENSOR

NGAT0218
NGAT0218S01

- Check resistance between terminals 1, 2 and 3.

Terminal No.		Resistance (Approx.)
1	2	2.4 - 2.8 kΩ
1	3	No continuity
2	3	No continuity

DTC CONTROL UNIT (RAM), CONTROL UNIT (ROM)

Description

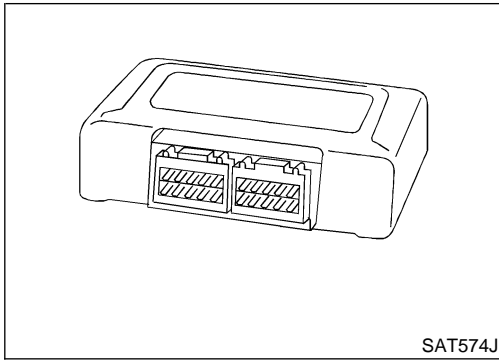

Description

The TCM consists of a microcomputer and connectors for signal input and output and for power supply. The unit controls the A/T. NGAT0206S01

ON BOARD DIAGNOSIS LOGIC

NGAT0206S0101

Diagnostic trouble code	Malfunction is detected when ...	Check Items (Possible Cause)
① : CONTROL UNIT (RAM) : CONTROL UNIT (ROM)	<ul style="list-style-type: none"> TCM memory (RAM) or (ROM) is malfunctioning. 	<ul style="list-style-type: none"> TCM

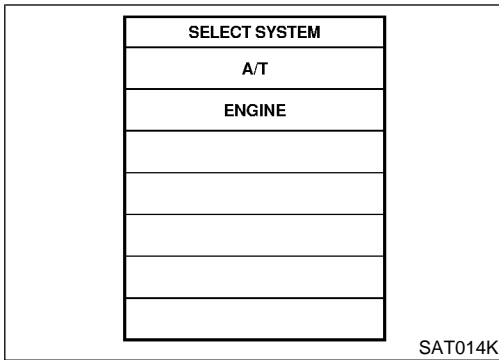

DIAGNOSTIC TROUBLE CODE (DTC) CONFIRMATION PROCEDURE

NGAT0206S0102

NOTE:

If "DTC Confirmation Procedure" has been previously conducted, always turn ignition switch OFF and wait at least 5 seconds before conducting the next test.

① With CONSULT-II

- 1) Turn ignition switch ON and select "DATA MONITOR" mode for A/T with CONSULT-II.
- 2) Start engine.
- 3) Run engine for at least 2 seconds at idle speed.

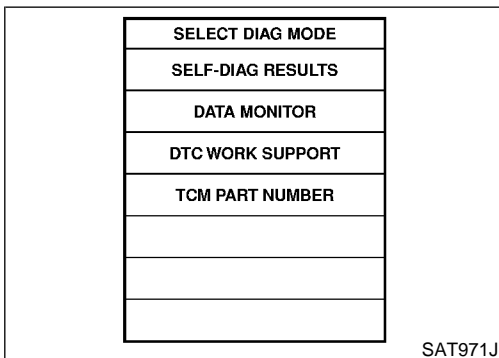

DTC CONTROL UNIT (RAM), CONTROL UNIT (ROM)

Diagnostic Procedure

Diagnostic Procedure

=NGAT0206S04

1	INSPECTION START	
<p> With CONSULT-II</p> <ol style="list-style-type: none"> 1. Turn ignition switch ON and select "SELF DIAG RESULTS" mode for A/T with CONSULT-II. 2. Touch "ERASE". 3. Perform "DIAGNOSTIC TROUBLE CODE (DTC) CONFIRMATION PROCEDURE", refer to AT-208. 4. Is the "CONTROL UNIT (RAM)" or "CONTROL UNIT (ROM)" displayed again? <p style="text-align: center;">Yes or No</p>		
Yes	▶	Replace TCM.
No	▶	INSPECTION END

GI

MA

EM

LC

EC

FE

CL

MT

AT

TF

PD

AX

SU

BR

ST

RS

BT

HA

SC

EL

IDX

DTC CONTROL UNIT (EEP ROM)

Description

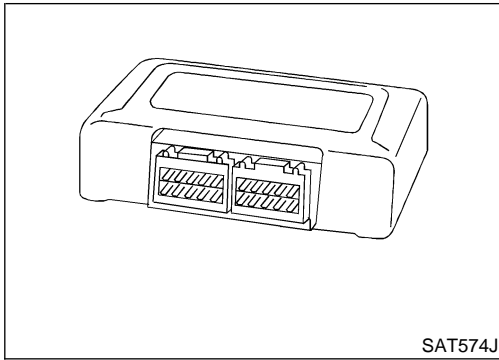

Description

The TCM consists of a microcomputer and connectors for signal input and output and for power supply. The unit controls the A/T. NGAT0208S01

ON BOARD DIAGNOSIS LOGIC

NGAT0208S0101

Diagnostic trouble code	Malfunction is detected when ...	Check item (possible cause)
Ⓛ : CONT UNIT (EEP ROM)	TCM memory (EEP ROM) is malfunctioning.	TCM

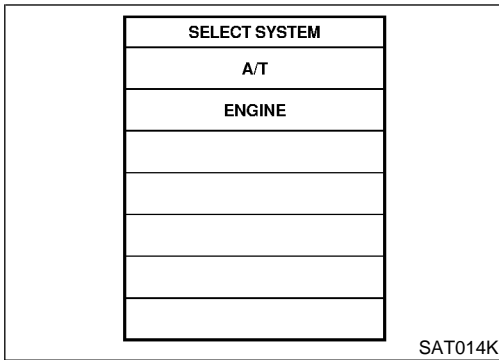

DIAGNOSTIC TROUBLE CODE (DTC) CONFIRMATION PROCEDURE

NGAT0208S0102

NOTE:

If "DIAGNOSTIC TROUBLE CODE CONFIRMATION PROCEDURE" has been previously conducted, always turn ignition switch OFF and wait at least 5 seconds before conducting the next test.

Ⓛ With CONSULT-II

- 1) Turn ignition switch ON and select "DATA MONITOR" mode for "A/T" with CONSULT-II.
- 2) Start engine.
- 3) Run engine for at least 2 seconds at idle speed.

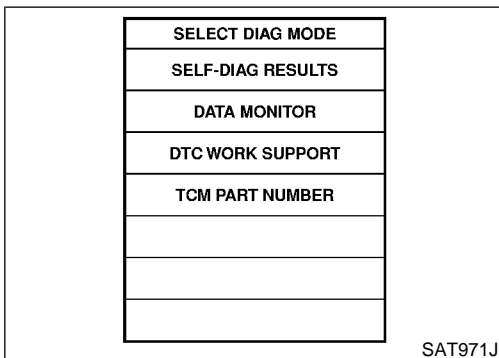

DTC CONTROL UNIT (EEP ROM)

Diagnostic Procedure

Diagnostic Procedure

NGAT0208S02

1	CHECK DTC	
<p> With CONSULT-II</p> <ol style="list-style-type: none"> 1. Turn ignition switch ON and select "SELF DIAG RESULTS" mode for A/T with CONSULT-II. 2. Move selector lever to "R" position. 3. Depress accelerator pedal (Full throttle position). 4. Touch "ERASE". 5. Turn ignition switch OFF for 10 seconds. PERFORM DIAGNOSTIC TROUBLE CODE (DTC) CONFIRMATION PROCEDURE. See previous page. <p style="text-align: center;">Is the "CONT UNIT (EEP ROM)" displayed again?</p>		
Yes	▶	Replace TCM
No	▶	INSPECTION END

GI
MA
EM
LC
EC
FE
CL
MT
AT
TF
PD
AX
SU
BR
ST
RS
BT
HA
SC
EL
IDX

TROUBLE DIAGNOSES FOR SYMPTOMS

Wiring Diagram — AT — NONDTC

Wiring Diagram — AT — NONDTC

NGAT0203

AT-NONDTC-01

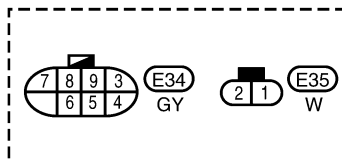
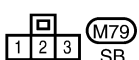
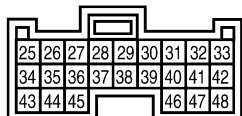
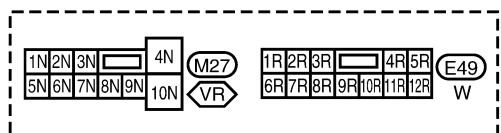
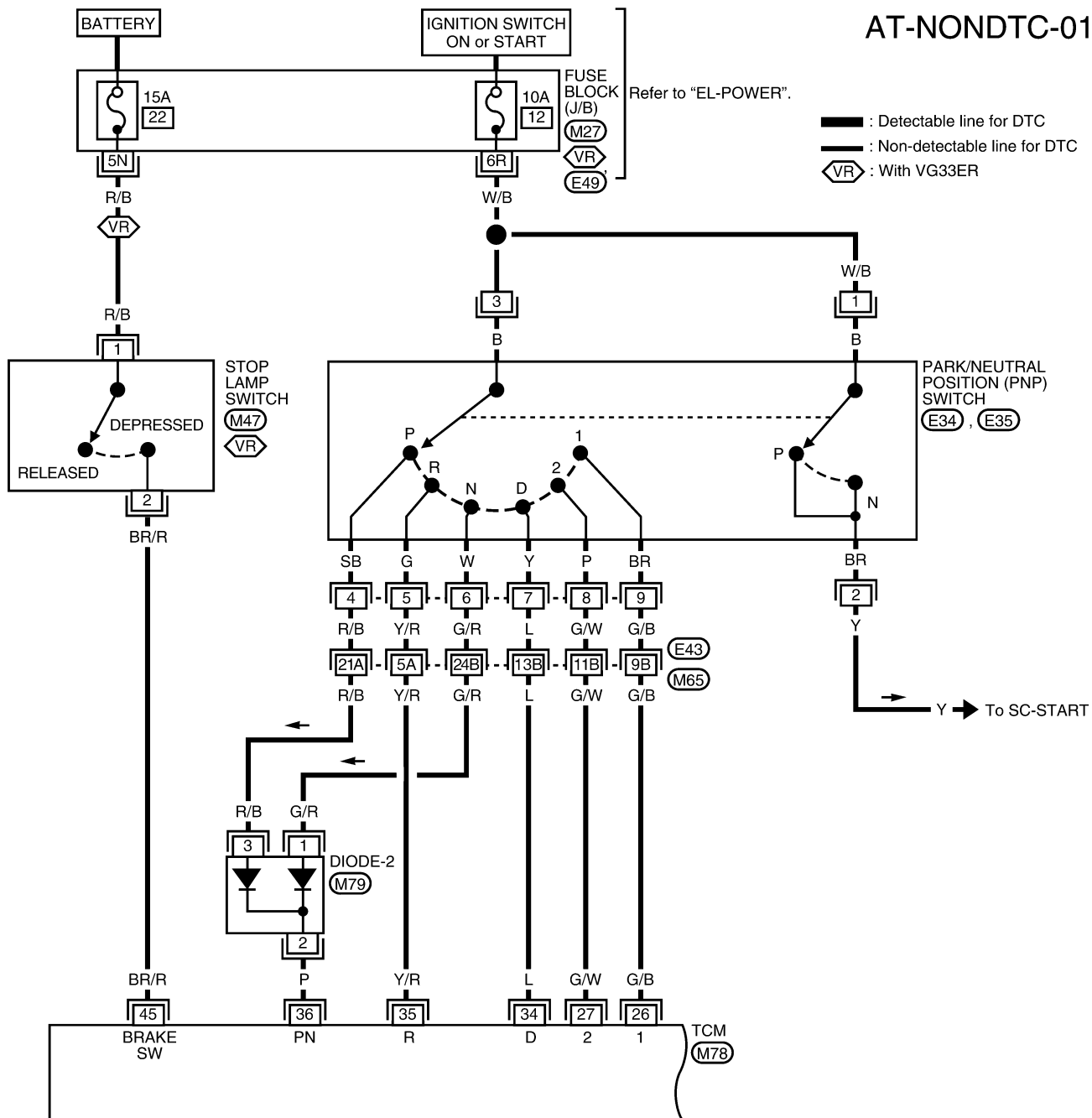

Refer to the following.
 (M65), (E43) - SUPER
 MULTIPLE JUNCTION (SMJ)

WAT517

TROUBLE DIAGNOSES FOR SYMPTOMS

Wiring Diagram — AT — NONDTC (Cont'd)

AT-NONDTC-02

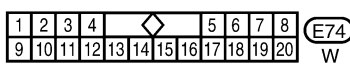
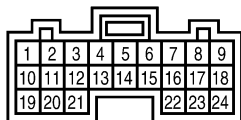
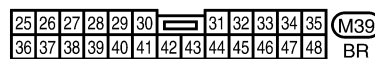
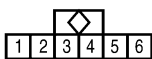
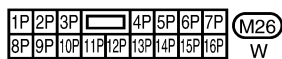
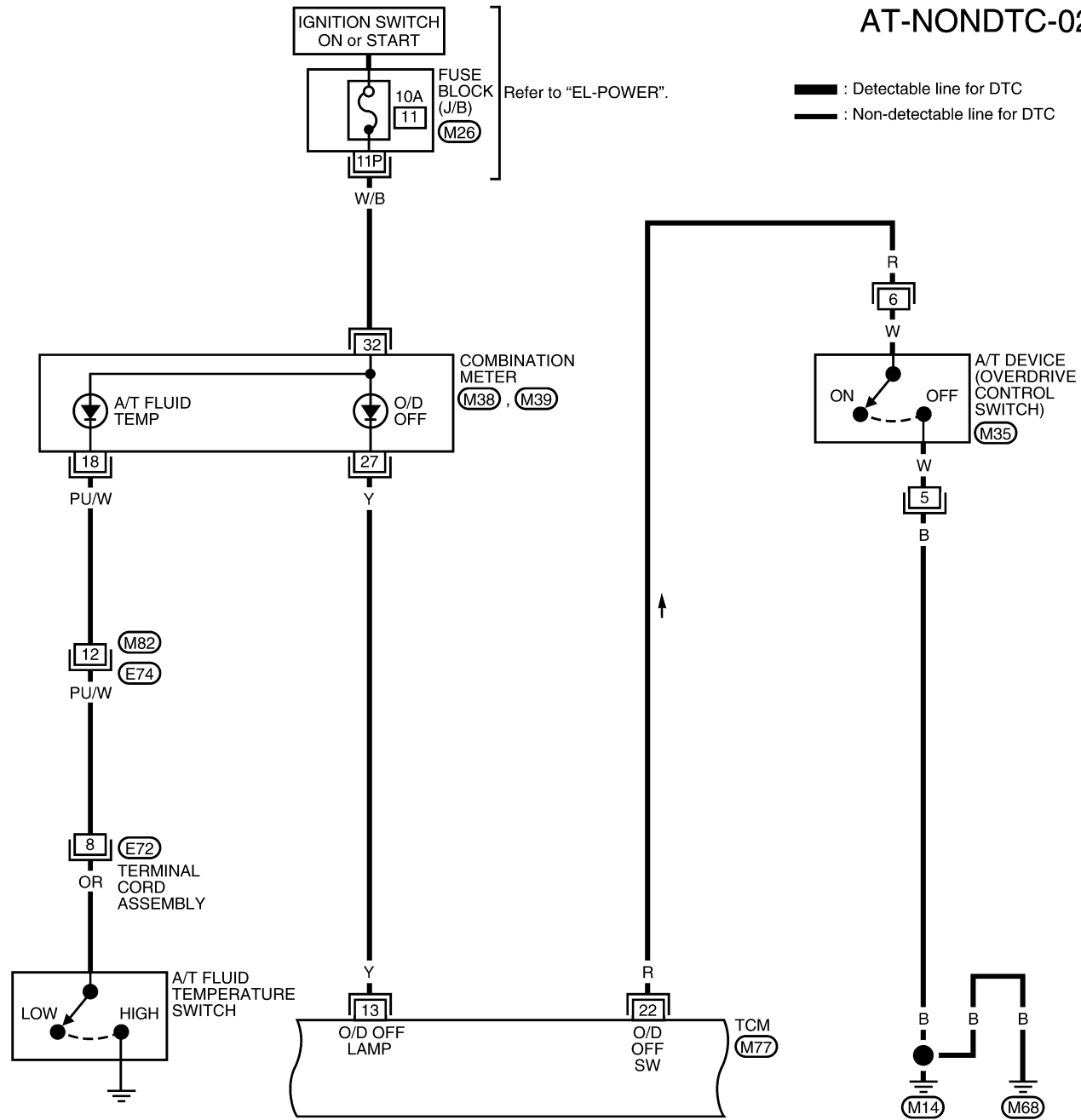

LAT492

GI
MA
EM
LC
EC
FE
CL
MT
AT
TF
PD
AX
SU
BR
ST
RS
BT
HA
SC
EL
IDX

TROUBLE DIAGNOSES FOR SYMPTOMS

Wiring Diagram — AT — NONDTC (Cont'd)

AT-NONDTC-03

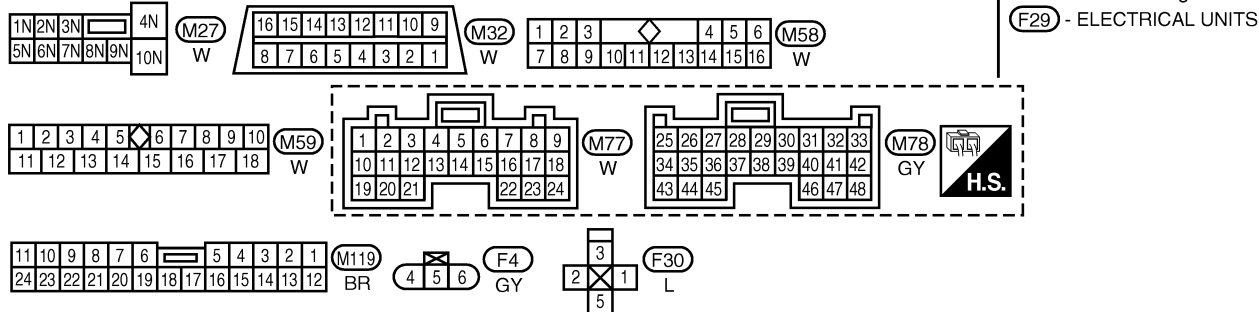
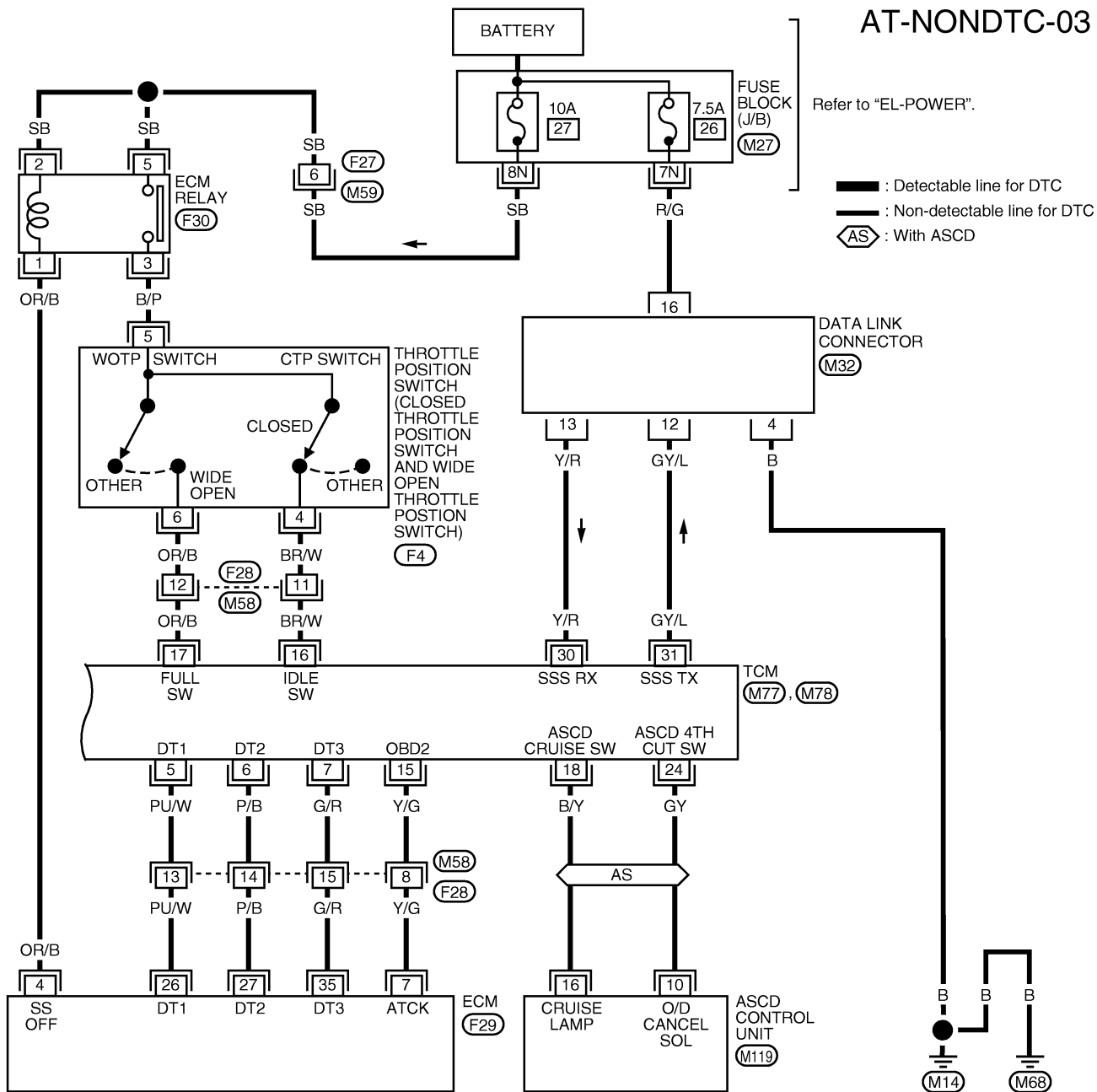

TROUBLE DIAGNOSES FOR SYMPTOMS

1. O/D OFF Indicator Lamp Does Not Come On

1. O/D OFF Indicator Lamp Does Not Come On

NGAT0073

SYMPTOM:

O/D OFF indicator lamp does not come on for about 2 seconds when turning ignition switch to ON.

1	CHECK TCM POWER SOURCE	<p>1. Turn ignition switch to ON position. (Do not start engine.)</p> <p>2. Check voltage between TCM terminals (10, 19, 28) and ground.</p> <div style="text-align: center;"> </div> <p style="text-align: right;">AAT476A</p> <p>Voltage: Battery voltage</p> <p>3. Turn ignition switch to OFF position.</p> <p>4. Check voltage between TCM terminal 28 and ground.</p> <p>Voltage: Battery voltage</p> <p style="text-align: center;">OK or NG</p>	GI MA EM LC EC FE CL MT
OK	▶	GO TO 2.	AT
NG	▶	<p>Check the following items:</p> <ul style="list-style-type: none"> ● Harness for short or open between ignition switch and TCM (Main harness) ● Refer to "Wiring Diagram — AT — MAIN", AT-101. ● Ignition switch and fuse <p>Refer to EL-10, "POWER SUPPLY ROUTING".</p>	TF PD

2	CHECK TCM GROUND CIRCUIT	<p>1. Turn ignition switch to OFF position.</p> <p>2. Disconnect TCM harness connector.</p> <p>3. Check resistance between TCM terminals (25, 48) and ground. Refer to "Wiring Diagram — AT — MAIN", AT-101. If OK, check harness for short to ground and short to power.</p> <p style="text-align: center;">Is resistance approx. 0Ω?</p>	AX SU BR
Yes	▶	GO TO 3.	RS
No	▶	<ul style="list-style-type: none"> ● Repair open circuit or short to ground or short to power in harness or connectors. ● Refer to "Wiring Diagram — AT — MAIN", AT-101. 	ST BT HA SC EL IDX

TROUBLE DIAGNOSES FOR SYMPTOMS

1. O/D OFF Indicator Lamp Does Not Come On (Cont'd)

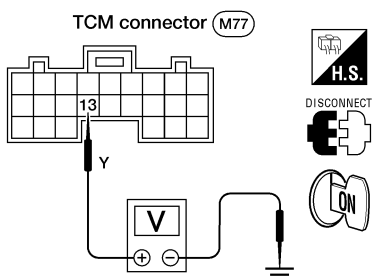
3	CHECK LAMP CIRCUIT	<p>1. Turn ignition switch to ON position. 2. Set overdrive control switch to ON position. 3. Check voltage between TCM connector M77 terminal 13 and ground.</p> <div style="text-align: center;">  </div> <p style="text-align: right;">AAT505A</p> <p style="text-align: center;">Does battery voltage exist?</p>
Yes	▶	GO TO 4.
No	▶	<p>Check the following items.</p> <ul style="list-style-type: none"> ● Fuse ● O/D OFF indicator lamp Refer to EL-94, "WARNING LAMPS". ● Harness for short or open between ignition switch and O/D OFF indicator lamp (Main harness) ● Refer to EL-10, "POWER SUPPLY ROUTING". ● Harness for short or open between O/D OFF indicator lamp and TCM

4	CHECK SYMPTOM	<p>Check again.</p> <p style="text-align: center;">OK or NG</p>
OK	▶	INSPECTION END
NG	▶	<p>1. Perform TCM input/output signal inspection. 2. If NG, recheck TCM pin terminals for damage or loose connection with harness connector.</p>

TROUBLE DIAGNOSES FOR SYMPTOMS



2. Engine Cannot Be Started In P and N Position

2. Engine Cannot Be Started In P and N Position

=NGAT0074

SYMPTOM:

Engine cannot be started with selector lever in P or N position.
 Engine cannot be started with selector lever in P. Engine can be started with selector lever in D, 2, 1 or R position.

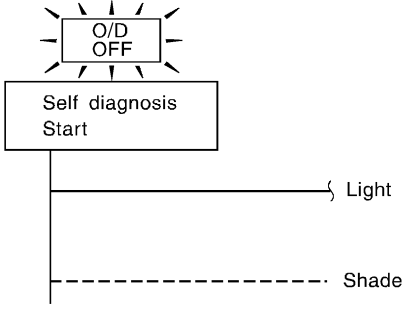
1	CHECK PNP SWITCH CIRCUIT
<p> With CONSULT-II Does "TCM INPUT SIGNALS" in Data Monitor show damage to PNP switch circuit?</p>	
<p> Without CONSULT-II Does self-diagnosis show damage to PNP switch circuit?</p>	
 <p>The diagram shows a box labeled "Self diagnosis Start" with a light symbol and a dashed line labeled "Shade". Above it is a box labeled "O/D OFF" with radiating lines.</p>	
Yes or No	
Yes	▶ Check PNP switch circuit. Refer to "DTC P0705", AT-104.
No	▶ GO TO 2.

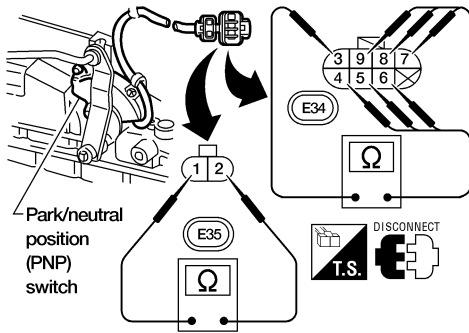
2	CHECK PNP SWITCH INSPECTION
<p>Check for short or open of PNP switch 2-pin connector. Refer to "Components Inspection", AT-109.</p>	
 <p>The diagram shows a "Park/neutral position (PNP) switch" with terminals 1 and 2. It is connected to a multimeter (E35) and a connector (E34) with terminals 3, 4, 5, 6, 7, 8, 9. A "DISCONNECT T.S." symbol is also shown.</p>	
OK or NG	
OK	▶ GO TO 3.
NG	▶ Repair or replace PNP switch.

3	CHECK STARTING SYSTEM
<p>Check starting system. Refer to SC-10, "System Description".</p>	
OK or NG	
OK	▶ INSPECTION END
NG	▶ Repair or replace damaged parts.

TROUBLE DIAGNOSES FOR SYMPTOMS

3. In "P" Position, Vehicle Moves Forward Or Backward When Pushed

3. In "P" Position, Vehicle Moves Forward Or Backward When Pushed

=NGAT0075

SYMPTOM:

Vehicle moves when it is pushed forward or backward with selector lever in P position.

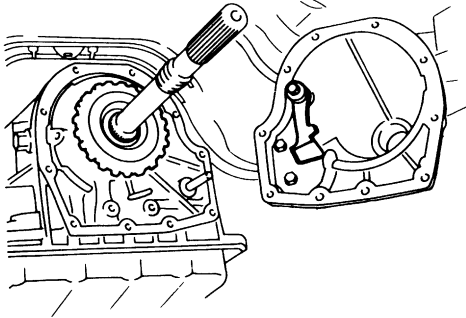
1	CHECK PARKING COMPONENTS
<p>Check parking components. Refer to "Parking Pawl Components", AT-329.</p> <div data-bbox="570 478 1032 793" data-label="Image"></div> <p data-bbox="1390 785 1471 806">SAT133B</p> <p data-bbox="756 827 867 848">OK or NG</p>	
OK	▶ INSPECTION END
NG	▶ Repair or replace damaged parts.

TROUBLE DIAGNOSES FOR SYMPTOMS



4. In N Position, Vehicle Moves

4. In N Position, Vehicle Moves

=NGAT0076

SYMPTOM:

Vehicle moves forward or backward when selecting N position.

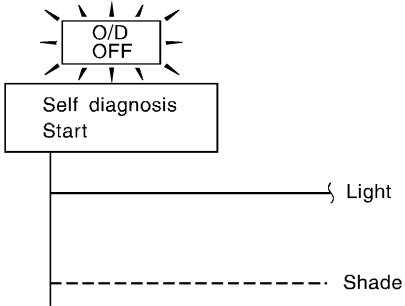
1	CHECK PNP SWITCH CIRCUIT
<p> With CONSULT-II Does "TCM INPUT SIGNALS" in Data Monitor show damage to PNP switch circuit?</p> <p> Without CONSULT-II Does self-diagnosis show damage to PNP switch circuit?</p>	
	
SAT367J	
Yes or No	
Yes	▶ Check PNP switch circuit. Refer to "DTC P0705", AT-104.
No	▶ GO TO 2.

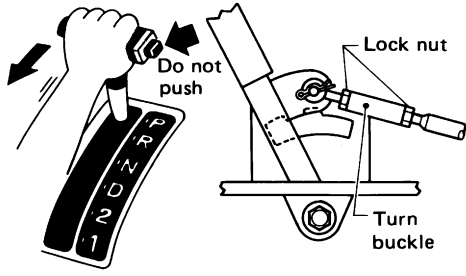
2	CHECK CONTROL LINKAGE
<p>Check control linkage. Refer to "Manual Control Linkage Adjustment", AT-270.</p>	
<p>"P" position</p> 	
SAT032G	
OK or NG	
OK	▶ GO TO 3.
NG	▶ Adjust control linkage. Refer to "Manual Control Linkage Adjustment", AT-270.

GI
MA
EM
LC
EC
FE
CL
MT
AT
TF
PD
AX
SU
BR
ST
RS
BT
HA
SC
EL
IDX

TROUBLE DIAGNOSES FOR SYMPTOMS

4. In N Position, Vehicle Moves (Cont'd)

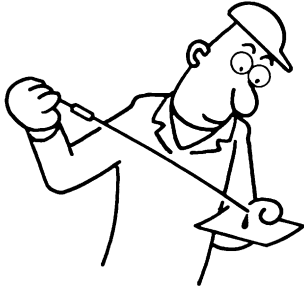
3	CHECK A/T FLUID LEVEL	Check A/T fluid level again.	
		SAT638A	
OK or NG			
OK	▶	GO TO 4.	
NG	▶	Refill ATF.	

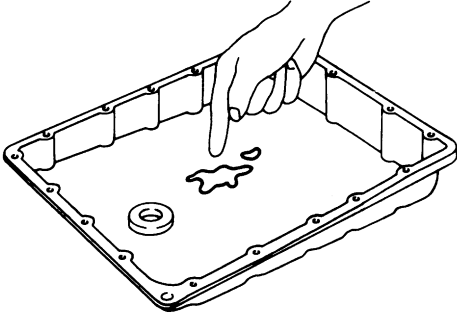
4	CHECK A/T FLUID CONDITION	1. Remove oil pan. 2. Check A/T fluid condition.	
		SAT171B	
OK or NG			
OK	▶	GO TO 5.	
NG	▶	1. Disassemble A/T. 2. Check the following items: <ul style="list-style-type: none"> ● Forward clutch assembly ● Overrun clutch assembly ● Reverse clutch assembly 	

5	CHECK SYMPTOM	Check again.	
OK or NG			
OK	▶	INSPECTION END	
NG	▶	1. Perform TCM input/output signal inspection. 2. If NG, recheck TCM pin terminals for damage or loose connection with harness connector.	

TROUBLE DIAGNOSES FOR SYMPTOMS

5. Large Shock. N → R Position

5. Large Shock. N → R Position

=NGAT0077

SYMPTOM:

There is large shock when changing from N to R position.

1	CHECK SELF-DIAGNOSTIC RESULTS	
Does self-diagnosis show damage to A/T fluid temperature sensor, line pressure solenoid valve or throttle position sensor circuit?		
<div style="display: flex; justify-content: space-around;"> <div style="text-align: center;"> <p>VG33E only</p> </div> <div style="text-align: center;"> <p>VG33ER only</p> </div> </div> <p style="text-align: right;">LAT456</p>		
Yes or No		
Yes	▶	Check damaged circuit. Refer to "DTC P0710 A/T FLUID TEMPERATURE SENSOR", "DTC P0745 LINE PRESSURE SOLENOID VALVE" or "DTC P1705 THROTTLE POSITION SENSOR", AT-113, 167 or 183.
No	▶	GO TO 2.

2	CHECK THROTTLE POSITION SENSOR	
Check throttle position sensor. Refer to EC-780 (VG33E only) or EC-1353 (VG33ER only), "DTC P0121, P0122, P0123 TP SENSOR".		
<p style="text-align: right;">AAT495A</p>		
OK or NG		
OK	▶	GO TO 3.
NG	▶	Repair or replace throttle position sensor.

GI

MA

EM

LC

EC

FE

CL

MT

AT

TF

PD

AX

SU

BR

ST

RS

BT

HA

SC

EL

IDX

TROUBLE DIAGNOSES FOR SYMPTOMS

5. Large Shock. N → R Position (Cont'd)

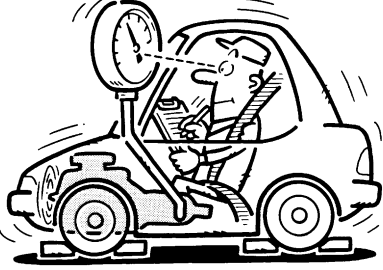
3	CHECK LINE PRESSURE	<p>Check line pressure at idle with selector lever in D position. Refer to "Line Pressure Test", AT-65.</p> <div style="text-align: center;">  </div> <p style="text-align: right;">SAT494G</p> <p style="text-align: center;">OK or NG</p>	
OK	▶	GO TO 4.	
NG	▶	<ol style="list-style-type: none"> 1. Remove control valve assembly. Refer to "Control Valve Assembly and Accumulators", AT-267. 2. Check the following items: <ul style="list-style-type: none"> ● Valves to control line pressure (Pressure regulator valve, pressure modifier valve, pilot valve and pilot filter) ● Line pressure solenoid valve 	

4	CHECK SYMPTOM	<p>Check again.</p> <p style="text-align: center;">OK or NG</p>	
OK	▶	INSPECTION END	
NG	▶	<ol style="list-style-type: none"> 1. Perform TCM input/output signal inspection. 2. If NG, recheck TCM pin terminals for damage or loose connection with harness connector. 	

TROUBLE DIAGNOSES FOR SYMPTOMS

6. Vehicle Does Not Creep Backward In R Position

6. Vehicle Does Not Creep Backward In R Position

=NGAT0078

SYMPTOM:

Vehicle does not creep backward when selecting R position.

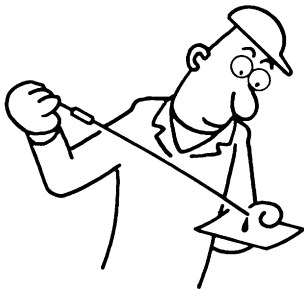
1	CHECK A/T FLUID LEVEL	<p>Check A/T fluid level again.</p> <div style="text-align: center;">  </div> <p style="text-align: right;">SAT638A</p> <p style="text-align: center;">OK or NG</p>	
OK	▶	GO TO 2.	
NG	▶	Refill ATF.	

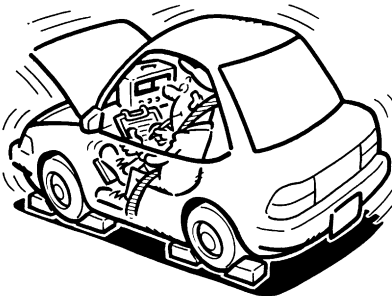
2	CHECK STALL TEST	<p>Check stall revolution with selector lever in 1 and R positions. Refer to "Stall Test", AT-62.</p> <div style="text-align: center;">  </div> <p style="text-align: right;">SAT493G</p> <p style="text-align: center;">OK or NG</p>	
OK	▶	GO TO 3.	
OK in "1" position, NG in R position	▶	<ol style="list-style-type: none"> 1. Remove control valve assembly. Refer to "Control Valve Assembly and Accumulators", AT-267. 2. Check the following items: <ul style="list-style-type: none"> ● Valves to control line pressure (Pressure regulator valve, pressure modifier valve, pilot valve and pilot filter) ● Line pressure solenoid valve 3. Disassemble A/T. 4. Check the following items: <ul style="list-style-type: none"> ● Oil pump assembly ● Torque converter ● Reverse clutch assembly ● High clutch assembly 	
NG in both 1 and R positions	▶	GO TO 6.	

GI
MA
EM
LC
EC
FE
CL
MT
AT
TF
PD
AX
SU
BR
ST
RS
BT
HA
SC
EL
IDX

TROUBLE DIAGNOSES FOR SYMPTOMS

6. Vehicle Does Not Creep Backward In R Position (Cont'd)

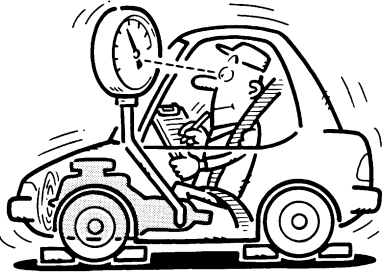
3	CHECK LINE PRESSURE	<p>Check line pressure at idle with selector lever in R position. Refer to "Line Pressure Test", AT-65.</p> <div style="text-align: center;">  </div> <p style="text-align: right;">SAT494G</p> <p style="text-align: center;">OK or NG</p>
OK	▶	GO TO 4.
NG	▶	<ol style="list-style-type: none"> 1. Remove control valve assembly. Refer to "Control Valve Assembly and Accumulators", AT-267. 2. Check the following items: <ul style="list-style-type: none"> ● Valves to control line pressure (Pressure regulator valve, pressure modifier valve, pilot valve and pilot filter) ● Line pressure solenoid valve 3. Disassemble A/T. 4. Check the following items: <ul style="list-style-type: none"> ● Oil pump assembly

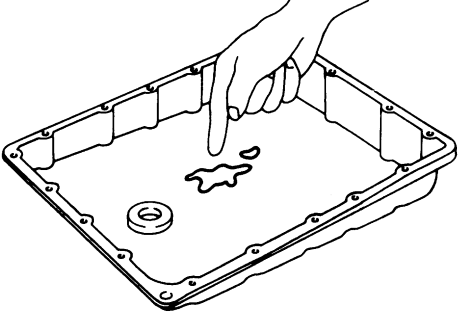
4	CHECK A/T FLUID CONDITION	<ol style="list-style-type: none"> 1. Remove oil pan. 2. Check A/T fluid condition. <div style="text-align: center;">  </div> <p style="text-align: right;">SAT171B</p> <p style="text-align: center;">OK or NG</p>
OK	▶	GO TO 5.
NG	▶	GO TO 6.

5	CHECK SYMPTOM	<p>Check again.</p> <p style="text-align: center;">OK or NG</p>
OK	▶	INSPECTION END
NG	▶	<ol style="list-style-type: none"> 1. Perform TCM input/output signal inspection. 2. If NG, recheck TCM pin terminals for damage or loose connection with harness connector.

TROUBLE DIAGNOSES FOR SYMPTOMS

6. Vehicle Does Not Creep Backward In R Position (Cont'd)

6	DETECT MALFUNCTIONING ITEM
<p>1. Remove control valve assembly. Refer to "Control Valve Assembly and Accumulators", AT-267.</p> <p>2. Check the following items:</p> <ul style="list-style-type: none"> ● Valves to control line pressure (Pressure regulator valve, pressure modifier valve, pilot valve and pilot filter) ● Line pressure solenoid valve <p>3. Disassemble A/T.</p> <p>4. Check the following items:</p> <ul style="list-style-type: none"> ● Oil pump assembly ● Torque converter ● Reverse clutch assembly ● High clutch assembly ● Low & reverse brake assembly ● Low one-way clutch 	
▶	Repair or replace damaged parts.

GI

MA

EM

LC

EC

FE

CL

MT

AT

TF

PD

AX

SU

BR

ST

RS

BT

HA

SC

EL

IDX

TROUBLE DIAGNOSES FOR SYMPTOMS

7. Vehicle Does Not Creep Forward In D, 2 Or 1 Position

7. Vehicle Does Not Creep Forward In D, 2 Or 1 Position

=NGAT0079

SYMPTOM:

Vehicle does not creep forward when selecting D, 2 or 1 position.

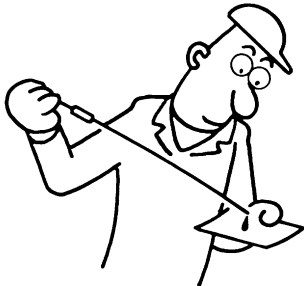
1	CHECK A/T FLUID LEVEL
Check A/T fluid level again.	
	
SAT638A	
OK or NG	
OK	▶ GO TO 2.
NG	▶ Refill ATF.

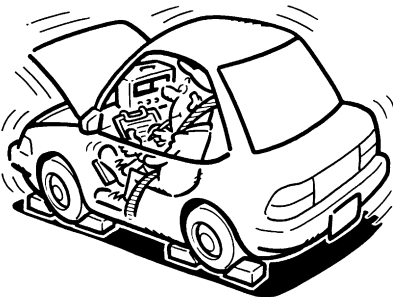
2	CHECK STALL TEST
Check stall revolution with selector lever in D position. Refer to "Stall Test", AT-62.	
	
SAT493G	
OK or NG	
OK	▶ GO TO 3.
NG	▶ GO TO 6.

TROUBLE DIAGNOSES FOR SYMPTOMS

7. Vehicle Does Not Creep Forward In D, 2 Or 1 Position (Cont'd)

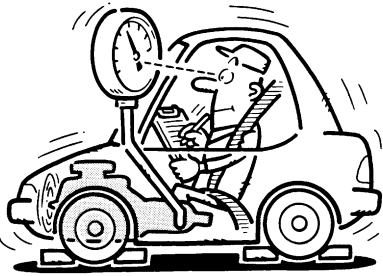
3	CHECK LINE PRESSURE	<p>Check line pressure at idle with selector lever in R position. Refer to "Line Pressure Test", AT-65.</p> <div style="text-align: center;">  </div> <p style="text-align: right;">SAT494G</p> <p style="text-align: center;">OK or NG</p>		GI MA EM LC EC FE CL MT
OK	▶	GO TO 4.		
NG	▶	<ol style="list-style-type: none"> 1. Remove control valve assembly. Refer to "Control Valve Assembly and Accumulators", AT-267. 2. Check the following items: <ul style="list-style-type: none"> ● Valves to control line pressure (Pressure regulator valve, pressure modifier valve, pilot valve and pilot filter) ● Line pressure solenoid valve 3. Disassemble A/T. 4. Check the following items: <ul style="list-style-type: none"> ● Oil pump assembly 		AT

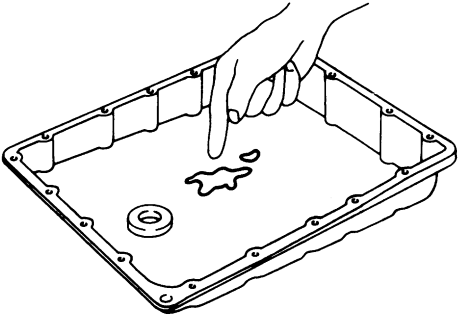
4	CHECK A/T FLUID CONDITION	<ol style="list-style-type: none"> 1. Remove oil pan. 2. Check A/T fluid condition. <div style="text-align: center;">  </div> <p style="text-align: right;">SAT171B</p> <p style="text-align: center;">OK or NG</p>		TF PD AX SU BR ST
OK	▶	GO TO 5.		
NG	▶	GO TO 6.		

5	CHECK SYMPTOM	<p>Check again.</p> <p style="text-align: center;">OK or NG</p>		BT HA
OK	▶	INSPECTION END		
NG	▶	<ol style="list-style-type: none"> 1. Perform TCM input/output signal inspection. 2. If NG, recheck TCM pin terminals for damage or loose connection with harness connector. 		SC EL

TROUBLE DIAGNOSES FOR SYMPTOMS

7. Vehicle Does Not Creep Forward In D, 2 Or 1 Position (Cont'd)

6	DETECT MALFUNCTIONING ITEM
<p>1. Remove control valve assembly. Refer to "Control Valve Assembly and Accumulators", AT-267.</p> <p>2. Check the following items:</p> <ul style="list-style-type: none">● Valves to control line pressure (Pressure regulator valve, pressure modifier valve, pilot valve and pilot filter)● Line pressure solenoid valve <p>3. Disassemble A/T.</p> <p>4. Check the following items:</p> <ul style="list-style-type: none">● Oil pump assembly● Forward clutch assembly● Forward one-way clutch● Low one-way clutch● Low & reverse brake assembly● Torque converter	
▶	Repair or replace damaged parts.

TROUBLE DIAGNOSES FOR SYMPTOMS

8. Vehicle Cannot Be Started From D₁

8. Vehicle Cannot Be Started From D₁

=NGAT0080

SYMPTOM:

Vehicle cannot be started from D₁ on Cruise test — Part 1.

1	CHECK SYMPTOM	
Is "6. Vehicle Does Not Creep Backward In R Position" OK?		
Yes or No		
Yes	▶	GO TO 2.
No	▶	Go to "6. Vehicle Does Not Creep Backward In R Position", AT-223.

2	CHECK SELF-DIAGNOSTIC RESULTS	
Does self-diagnosis show damage to vehicle speed sensor-A/T (revolution sensor), shift solenoid valve A, B or vehicle speed sensor-MTR after cruise test?		
SAT934FB		
Yes or No		
Yes	▶	Check damaged circuit. Refer to "DTC P0720 VEHICLE SPEED SENSOR-A/T (REVOLUTION SENSOR)", AT-119 "DTC P0750 SHIFT SOLENOID VALVE A", AT-172, "DTC P0755 SHIFT SOLENOID VALVE B", AT-177 or "DTC VEHICLE SPEED SENSOR. MTR", AT-202.
No	▶	GO TO 3.

3	CHECK THROTTLE POSITION SENSOR	
Check throttle position sensor. Refer to EC-780 (VG33E only) or EC-1353 (VG33ER only), "DTC P0121, P0122, P0123 TP SENSOR".		
AAT495A		
OK or NG		
OK	▶	GO TO 4.
NG	▶	Repair or replace throttle position sensor.

GI
 MA
 EM
 LC
 EC
 FE
 CL
 MT
AT
 TF
 PD
 AX
 SU
 BR
 ST
 RS
 BT
 HA
 SC
 EL
 IDX

TROUBLE DIAGNOSES FOR SYMPTOMS

8. Vehicle Cannot Be Started From D₁ (Cont'd)

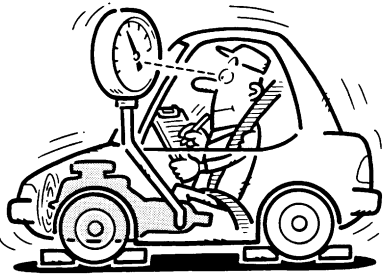
4	CHECK LINE PRESSURE	
<p>Check line pressure at stall point with selector lever in D position. Refer to "Line Pressure Test", AT-65.</p>		
		
SAT494G		
OK or NG		
OK	▶	GO TO 5.
NG	▶	GO TO 8.

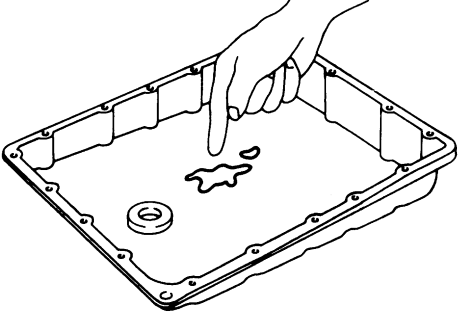
5	CHECK A/T FLUID CONDITION	
<p>1. Remove oil pan. 2. Check A/T fluid condition.</p>		
		
SAT171B		
OK or NG		
OK	▶	GO TO 6.
NG	▶	GO TO 8.

6	DETECT MALFUNCTIONING ITEM	
<p>1. Remove control valve assembly. Refer to "Control Valve Assembly and Accumulators", AT-267.</p> <p>2. Check the following items:</p> <ul style="list-style-type: none"> ● Shift valve A ● Shift valve B ● Shift solenoid valve A ● Shift solenoid valve B ● Pilot valve ● Pilot filter 		
OK or NG		
OK	▶	GO TO 7.
NG	▶	Repair or replace damaged parts.

TROUBLE DIAGNOSES FOR SYMPTOMS

8. Vehicle Cannot Be Started From D₁ (Cont'd)

7	CHECK SYMPTOM	
Check again.		
OK or NG		
OK	▶	INSPECTION END
NG	▶	<ol style="list-style-type: none"> 1. Perform TCM input/output signal inspection. 2. If NG, recheck TCM pin terminals for damage or loose connection with harness connector.

8	DETECT MALFUNCTIONING ITEM	
<ol style="list-style-type: none"> 1. Remove control valve assembly. Refer to "Control Valve Assembly and Accumulators", AT-267. 2. Check the following items: <ul style="list-style-type: none"> ● Shift valve A ● Shift valve B ● Shift solenoid valve A ● Shift solenoid valve B ● Pilot valve ● Pilot filter 3. Disassemble A/T. 4. Check the following items: <ul style="list-style-type: none"> ● Forward clutch assembly ● Forward one-way clutch ● Low one-way clutch ● High clutch assembly ● Torque converter ● Oil pump assembly 		
OK or NG		
OK	▶	GO TO 7.
NG	▶	Repair or replace damaged parts.

GI
 MA
 EM
 LC
 EC
 FE
 CL
 MT
AT
 TF
 PD
 AX
 SU
 BR
 ST
 RS
 BT
 HA
 SC
 EL
 IDX

TROUBLE DIAGNOSES FOR SYMPTOMS

9. A/T Does Not Shift: D₁ → D₂ Or Does Not Kickdown: D₄ → D₂

9. A/T Does Not Shift: D₁ → D₂ Or Does Not Kickdown: D₄ → D₂

=NGAT0081

SYMPTOM:

**A/T does not shift from D₁ to D₂ at the specified speed.
A/T does not shift from D₄ to D₂ when depressing accelerator pedal fully at the specified speed.**

1	CHECK SYMPTOM	
Are "7. Vehicle Does Not Creep Forward In D, 2 Or 1 Position" and "8. Vehicle Cannot Be Started From D ₁ " OK?		
Yes or No		
Yes	▶	GO TO 2.
No	▶	Go to "7. Vehicle Does Not Creep Forward In D, 2 Or 1 Position" and "8. Vehicle Cannot Be Started From D ₁ ", AT-226, 229.

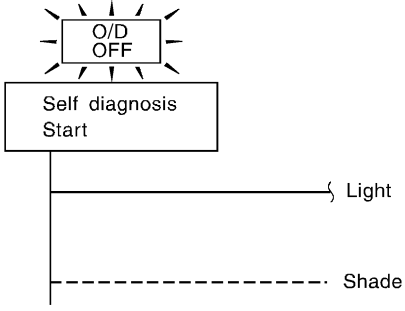
2	CHECK PNP SWITCH CIRCUIT	
<input checked="" type="checkbox"/> With CONSULT-II Does "TCM INPUT SIGNALS" in Data Monitor show damage to PNP switch circuit?		
<input type="checkbox"/> Without CONSULT-II Does self-diagnosis show damage to PNP switch circuit?		
		
Yes or No		
Yes	▶	Check PNP switch circuit. Refer to "Diagnostic Procedure", AT-107.
No	▶	GO TO 3.

SAT367J

3	CHECK VEHICLE SPEED SENSOR-A/T AND VEHICLE SPEED SENSOR-MTR CIRCUIT	
Check vehicle speed sensor-A/T (revolution sensor) and vehicle speed sensor-MTR circuit. Refer to "DTC P0720 VEHICLE SPEED SENSOR (REVOLUTION SENSOR)", AT-119 and "VEHICLE SPEED SENSOR-MTR", AT-202.		
OK or NG		
OK	▶	GO TO 4.
NG	▶	Repair or replace vehicle speed sensor-A/T (revolution sensor) and vehicle speed sensor-MTR circuits.

TROUBLE DIAGNOSES FOR SYMPTOMS

9. A/T Does Not Shift: $D_1 \rightarrow D_2$ Or Does Not Kickdown: $D_4 \rightarrow D_2$ (Cont'd)

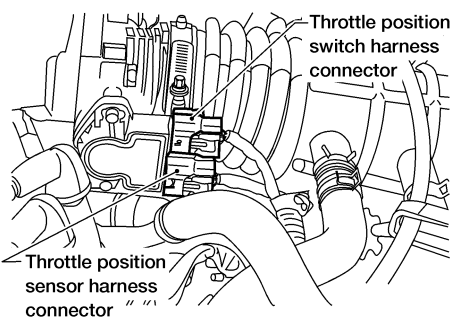
4	CHECK THROTTLE POSITION SENSOR	
<p>Check throttle position sensor. Refer to EC-780 (VG33E only) or EC-1353(VG33ER only), "DTC P0121, P0122, P0123 TP SENSOR".</p>		
 <p>Throttle position switch harness connector</p> <p>Throttle position sensor harness connector</p>		
AAT495A		
OK or NG		
OK	▶	GO TO 5.
NG	▶	Repair or replace throttle position sensor.

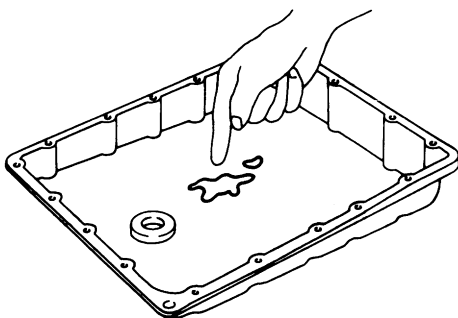
5	CHECK A/T FLUID CONDITION	
<p>1. Remove oil pan. 2. Check A/T fluid condition.</p>		
		
SAT171B		
OK or NG		
OK	▶	GO TO 6.
NG	▶	GO TO 8.

6	DETECT MALFUNCTIONING ITEM	
<p>1. Remove control valve assembly. Refer to "Control Valve Assembly and Accumulators", AT-267. 2. Check the following items:</p> <ul style="list-style-type: none"> ● Shift valve A ● Shift solenoid valve A ● Pilot valve ● Pilot filter 		
OK or NG		
OK	▶	GO TO 7.
NG	▶	Repair or replace damaged parts.

GI
MA
EM
LC
EC
FE
CL
MT
AT
TF
PD
AX
SU
BR
ST
RS
BT
HA
SC
EL
IDX

TROUBLE DIAGNOSES FOR SYMPTOMS

9. A/T Does Not Shift: $D_1 \rightarrow D_2$ Or Does Not Kickdown: $D_4 \rightarrow D_2$ (Cont'd)

7	CHECK SYMPTOM	
Check again.		
OK or NG		
OK	▶	INSPECTION END
NG	▶	<ol style="list-style-type: none"> 1. Perform TCM input/output signal inspection. 2. If NG, recheck TCM pin terminals for damage or loose connection with harness connector.

8	DETECT MALFUNCTIONING ITEM	
<ol style="list-style-type: none"> 1. Remove control valve assembly. Refer to "Control Valve Assembly and Accumulators", AT-267. 2. Check the following items: <ul style="list-style-type: none"> ● Shift valve A ● Shift solenoid valve A ● Pilot valve ● Pilot filter 3. Disassemble A/T. 4. Check the following items: <ul style="list-style-type: none"> ● Servo piston assembly ● Brake band ● Oil pump assembly 		
OK or NG		
OK	▶	GO TO 7.
NG	▶	Repair or replace damaged parts.

TROUBLE DIAGNOSES FOR SYMPTOMS

10. A/T Does Not Shift: D₂ → D₃

10. A/T Does Not Shift: D₂ → D₃

=NGAT0082

SYMPTOM:

A/T does not shift from D₂ to D₃ at the specified speed.

1	CHECK SYMPTOM	
Are "7. Vehicle Does Not Creep Forward In D, 2 Or 1 Position" and "8. Vehicle Cannot Be Started From D ₁ " OK?		
Yes or No		
Yes	▶	GO TO 2.
No	▶	Go to "7. Vehicle Does Not Creep Forward In D, 2 Or 1 Position" and "8. Vehicle Cannot Be Started From D ₁ ", AT-226, 229.

2	CHECK PNP SWITCH CIRCUIT	
<input type="checkbox"/> With CONSULT-II Does "TCM INPUT SIGNALS" in Data Monitor show damage to PNP switch circuit?		
<input checked="" type="checkbox"/> Without CONSULT-II Does self-diagnosis show damage to PNP switch circuit?		
Yes or No		
Yes	▶	Check PNP switch circuit. Refer to "Diagnostic Procedure", AT-107.
No	▶	GO TO 3.

3	CHECK THROTTLE POSITION SENSOR	
Check throttle position sensor. Refer to EC-780 (VG33E only) or EC-1353 (VG33ER only), "DTC P0121, P0122, P0123 TP SENSOR".		
OK or NG		
OK	▶	GO TO 4.
NG	▶	Repair or replace throttle position sensor.

GI

MA

EM

LC

EC

FE

CL

MT

AT

TF

PD

AX

SU

BR

ST

RS

BT

HA

SC

EL

IDX

TROUBLE DIAGNOSES FOR SYMPTOMS

10. A/T Does Not Shift: $D_2 \rightarrow D_3$ (Cont'd)

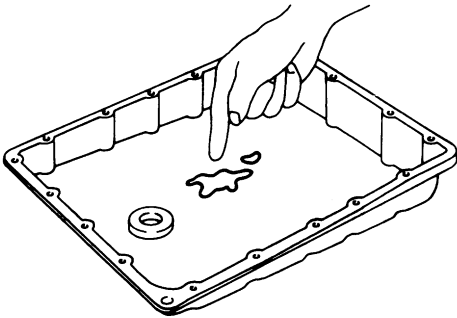
4	CHECK A/T FLUID CONDITION	
<p>1. Remove oil pan. 2. Check A/T fluid condition.</p>		
		
SAT171B		
OK or NG		
OK	▶	GO TO 5.
NG	▶	GO TO 7.

5	DETECT MALFUNCTIONING ITEM	
<p>1. Remove control valve assembly. Refer to "Control Valve Assembly and Accumulators", AT-267. 2. Check the following items:</p> <ul style="list-style-type: none"> ● Shift valve B ● Shift solenoid valve B ● Pilot valve ● Pilot filter 		
OK or NG		
OK	▶	GO TO 6.
NG	▶	Repair or replace damaged parts.

6	CHECK SYMPTOM	
Check again.		
OK or NG		
OK	▶	INSPECTION END
NG	▶	<p>1. Perform TCM input/output signal inspection. 2. If NG, recheck TCM pin terminals for damage or loose connection with harness connector.</p>

TROUBLE DIAGNOSES FOR SYMPTOMS

10. A/T Does Not Shift: D₂ → D₃ (Cont'd)

7	DETECT MALFUNCTIONING ITEM	
	1. Remove control valve assembly. Refer to "Control Valve Assembly and Accumulators", AT-267. 2. Check the following items: <ul style="list-style-type: none"> ● Shift valve B ● Shift solenoid valve B ● Pilot valve ● Pilot filter 3. Disassemble A/T. 4. Check the following items: <ul style="list-style-type: none"> ● Servo piston assembly ● High clutch assembly ● Oil pump assembly 	GI MA EM LC EC FE CL MT AT TF PD AX SU BR ST RS BT HA SC EL IDX
	OK or NG	
OK	▶	GO TO 6.
NG	▶	Repair or replace damaged parts.

TROUBLE DIAGNOSES FOR SYMPTOMS

11. A/T Does Not Shift: $D_3 \rightarrow D_4$

11. A/T Does Not Shift: $D_3 \rightarrow D_4$

=NGAT0083

SYMPTOM:

- A/T does not shift from D_3 to D_4 at the specified speed.
- A/T must be warm before D_3 to D_4 shift will occur.

1	CHECK SYMPTOM	
Are "7. Vehicle Does Not Creep Forward In D, 2 Or 1 Position" and "8. Vehicle Cannot Be Started From D_1 " OK?		
Yes or No		
Yes	▶	GO TO 2.
No	▶	Go to "7. Vehicle Does Not Creep Forward In D, 2 Or 1 Position" and "8. Vehicle Cannot Be Started From D_1 ", AT-226, 229.

2	CHECK SELF-DIAGNOSTIC RESULTS	
<p>Ⓜ With CONSULT-II Does self-diagnosis, after cruise test, show damage to any of the following circuits?</p> <ul style="list-style-type: none"> ● PNP switch ● Overdrive control switch ● A/T fluid temperature sensor ● Revolution sensor ● Shift solenoid valve A or B ● Vehicle speed sensor 		
SAT363HA		
Yes or No		
Yes	▶	Check damaged circuit. Refer to "DTC P1705 THROTTLE POSITION SENSOR", AT-179, "DTC P0710 A/T FLUID TEMPERATURE SENSOR", AT-113, "DTC P0720 VEHICLE SPEED SENSOR-A/T (REVOLUTION SENSOR)", AT-119, "DTC P0750 SHIFT SOLENOID VALVE A", AT-177, "DTC P0755 SHIFT SOLENOID VALVE B", AT-172, or "DTC VEHICLE SPEED SENSOR-MTR", AT-202.
No	▶	GO TO 3.

TROUBLE DIAGNOSES FOR SYMPTOMS

11. A/T Does Not Shift: D₃ → D₄ (Cont'd)

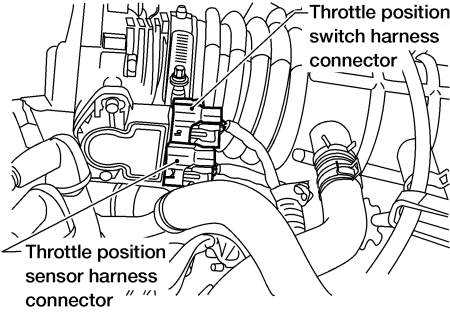
3	CHECK THROTTLE POSITION SENSOR	
<p>Check throttle position sensor. Refer to EC-780 (VG33E only) or EC-1353 (VG33ER only), "DTC P0121, P0122, P0123 TP SENSOR".</p>		
 <p>Throttle position switch harness connector</p> <p>Throttle position sensor harness connector</p>		
AAT495A		
OK or NG		
OK	▶	GO TO 4.
NG	▶	Repair or replace throttle position sensor.

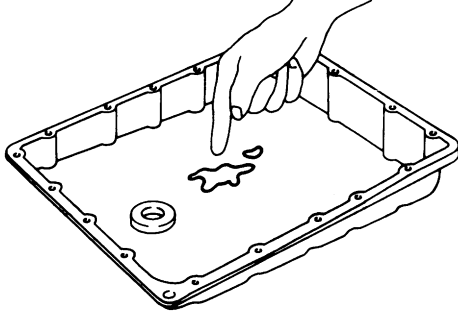
4	CHECK A/T FLUID CONDITION	
<p>1. Remove oil pan. 2. Check A/T fluid condition.</p>		
		
SAT171B		
OK or NG		
OK	▶	GO TO 5.
NG	▶	GO TO 7.

5	DETECT MALFUNCTIONING ITEM	
<p>1. Remove control valve assembly. Refer to "Control Valve Assembly and Accumulators", AT-267. 2. Check the following items:</p> <ul style="list-style-type: none"> ● Shift valve B ● Overrun clutch control valve ● Shift solenoid valve B ● Pilot valve ● Pilot filter 		
OK or NG		
OK	▶	GO TO 6.
NG	▶	Repair or replace damaged parts.

GI
MA
EM
LC
EC
FE
CL
MT
AT
TF
PD
AX
SU
BR
ST
RS
BT
HA
SC
EL
IDX

TROUBLE DIAGNOSES FOR SYMPTOMS

11. A/T Does Not Shift: $D_3 \rightarrow D_4$ (Cont'd)

6	CHECK SYMPTOM	
Check again.		
OK or NG		
OK	▶	INSPECTION END
NG	▶	<ol style="list-style-type: none"> 1. Perform TCM input/output signal inspection. 2. If NG, recheck TCM pin terminals for damage or loose connection with harness connector.

7	DETECT MALFUNCTIONING ITEM	
<ol style="list-style-type: none"> 1. Remove control valve assembly. Refer to "Control Valve Assembly and Accumulators", AT-267. 2. Check the following items: <ul style="list-style-type: none"> ● Shift valve B ● Overrun clutch control valve ● Shift solenoid valve B ● Pilot valve ● Pilot filter 3. Disassemble A/T. 4. Check the following items: <ul style="list-style-type: none"> ● Servo piston assembly ● Brake band ● Torque converter ● Oil pump assembly 		
OK or NG		
OK	▶	GO TO 6.
NG	▶	Repair or replace damaged parts.

TROUBLE DIAGNOSES FOR SYMPTOMS

12. A/T Does Not Perform Lock-up

12. A/T Does Not Perform Lock-up

=NGAT0084

SYMPTOM:

A/T does not perform lock-up at the specified speed.

1	CHECK SELF-DIAGNOSTIC RESULTS	
Does self-diagnosis show damage to torque converter clutch solenoid valve circuit after cruise test?		
Yes or No		
Yes	▶	Check torque converter clutch solenoid valve circuit. Refer to "Diagnostic Procedure", AT-155.
No	▶	GO TO 2.

2	CHECK THROTTLE POSITION SENSOR	
Check throttle position sensor. Refer to EC-780 (VG33E only) or EC-1353 (VG33ER only), "DTC P0121, P0122, P0123 TP SENSOR".		
OK or NG		
OK	▶	GO TO 3.
NG	▶	Repair or replace throttle position sensor.

3	DETECT MALFUNCTIONING ITEM	
1. Remove control valve assembly. Refer to "Control Valve Assembly and Accumulators", AT-267.		
2. Check following items:		
<ul style="list-style-type: none"> ● Torque converter clutch control valve ● Torque converter relief valve ● Torque converter clutch solenoid valve ● Pilot valve ● Pilot filter 		
OK or NG		
OK	▶	GO TO 4.
NG	▶	Repair or replace damaged parts.

GI

MA

EM

LC

EC

FE

CL

MT

AT

TF

PD

AX

SU

BR

ST

RS

BT

HA

SC

EL

IDX

TROUBLE DIAGNOSES FOR SYMPTOMS

12. A/T Does Not Perform Lock-up (Cont'd)

4	CHECK SYMPTOM
Check again.	
OK or NG	
OK	▶ INSPECTION END
NG	▶ 1. Perform TCM input/output signal inspection. 2. If NG, recheck TCM pin terminals for damage or loose connection with harness connector.

TROUBLE DIAGNOSES FOR SYMPTOMS

13. A/T Does Not Hold Lock-up Condition

13. A/T Does Not Hold Lock-up Condition

=NGAT0085

SYMPTOM:

A/T does not hold lock-up condition for more than 30 seconds.

1	CHECK DIAGNOSTIC RESULTS	
Does self-diagnosis show damage to engine speed signal circuit after cruise test?		
<p>The diagram illustrates the self-diagnosis process. At the top, a box labeled 'O/D OFF' has radiating lines above it. Below it, a box labeled 'Self-diagnosis start' has a vertical line leading to a series of vertical bars of varying heights, representing a signal waveform. A label 'Engine speed signal' points to this waveform. To the right, a horizontal line is labeled 'Light', and a dashed line below it is labeled 'Shade'.</p>		
SAT347H		
Yes or No		
Yes	▶	Check engine speed signal circuit. Refer to "Diagnostic Procedure", AT-123.
No	▶	GO TO 2.

2	CHECK A/T FLUID CONDITION	
<ol style="list-style-type: none"> 1. Remove oil pan. 2. Check A/T fluid condition. 		
<p>The diagram shows a hand pointing to a puddle of fluid on the surface of an oil pan. A bolt is visible on the pan's surface.</p>		
SAT171B		
OK or NG		
OK	▶	GO TO 3.
NG	▶	GO TO 5.

3	DETECT MALFUNCTIONING ITEM	
<ol style="list-style-type: none"> 1. Remove control valve assembly. Refer to "Control Valve Assembly and Accumulators", AT-267. 2. Check the following items: <ul style="list-style-type: none"> ● Torque converter clutch control valve ● Pilot valve ● Pilot filter 		
OK or NG		
OK	▶	GO TO 4.
NG	▶	Repair or replace damaged parts.

GI
MA
EM
LC
EC
FE
CL
MT
AT
TF
PD
AX
SU
BR
ST
RS
BT
HA
SC
EL
IDX

TROUBLE DIAGNOSES FOR SYMPTOMS

13. A/T Does Not Hold Lock-up Condition (Cont'd)

4	CHECK SYMPTOM	
Check again.		
OK or NG		
OK	▶	INSPECTION END
NG	▶	<ol style="list-style-type: none"> 1. Perform TCM input/output signal inspection. 2. If NG, recheck TCM pin terminals for damage or loose connection with harness connector.

5	DETECT MALFUNCTIONING ITEM	
<ol style="list-style-type: none"> 1. Remove control valve assembly. Refer to "Control Valve Assembly and Accumulators", AT-267. 2. Check the following items: <ul style="list-style-type: none"> ● Torque converter clutch control valve ● Pilot valve ● Pilot filter 3. Disassemble A/T. 4. Check torque converter and oil pump assembly. 		
OK or NG		
OK	▶	GO TO 4.
NG	▶	Repair or replace damaged parts.

TROUBLE DIAGNOSES FOR SYMPTOMS

14. Lock-up Is Not Released

14. Lock-up Is Not Released

=NGAT0086

SYMPTOM:

Lock-up is not released when accelerator pedal is released.

1	CHECK THROTTLE POSITION SWITCH CIRCUIT	
<p><input type="checkbox"/> With CONSULT-II Does "TCM INPUT SIGNALS" in Data Monitor show damage to closed throttle position switch circuit?</p> <p><input checked="" type="checkbox"/> Without CONSULT-II Does self-diagnosis show damage to closed throttle position switch circuit?</p>		
SAT367J		
Yes or No		
Yes	▶	Check closed throttle position switch circuit. Refer to "DTC P1705", AT-183.
No	▶	GO TO 2.

2	CHECK SYMPTOM	
Check again.		
OK or NG		
OK	▶	INSPECTION END
NG	▶	<ol style="list-style-type: none"> 1. Perform TCM input/output signal inspection. 2. If NG, recheck TCM pin terminals for damage or loose connection with harness connector.

GI

MA

EM

LC

EC

FE

CL

MT

AT

TF

PD

AX

SU

BR

ST

RS

BT

HA

SC

EL

IDX

TROUBLE DIAGNOSES FOR SYMPTOMS

15. Engine Speed Does Not Return To Idle (Light Braking $D_4 \rightarrow D_3$)

15. Engine Speed Does Not Return To Idle (Light Braking $D_4 \rightarrow D_3$)

=NGAT0087

SYMPTOM:

- Engine speed does not smoothly return to idle when A/T shifts from D_4 to D_3 .
- Vehicle does not decelerate by engine brake when turning overdrive control switch OFF.
- Vehicle does not decelerate by engine brake when shifting A/T from D to 2 position.

1	CHECK SELF-DIAGNOSTIC RESULTS	
Does self-diagnosis show damage to overrun clutch solenoid valve circuit after cruise test?		
SAT348H		
Yes or No		
Yes	▶	Check overrun clutch solenoid valve circuit. Refer to "Diagnostic Procedure", AT-191.
No	▶	GO TO 2.

2	CHECK THROTTLE POSITION SENSOR	
Check throttle position sensor. Refer to EC-780 (VG33E only) or EC-1353 (VG33ER only), "DTC P0121, P0122, P0123 TP SENSOR" ..		
AAT495A		
OK or NG		
OK	▶	GO TO 3.
NG	▶	Repair or replace throttle position sensor.

TROUBLE DIAGNOSES FOR SYMPTOMS

15. Engine Speed Does Not Return To Idle (Light Braking $D_4 \rightarrow D_3$) (Cont'd)

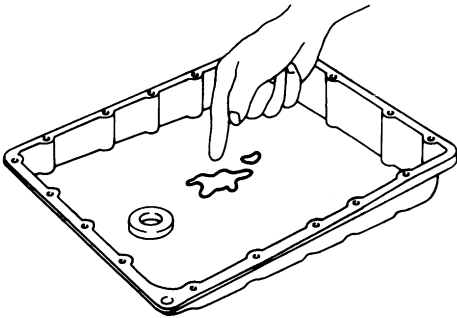
3	CHECK A/T FLUID CONDITION
<p>1. Remove oil pan. 2. Check A/T fluid condition.</p>	
	
SAT171B	
OK or NG	
OK	▶ GO TO 4.
NG	▶ GO TO 6.

4	DETECT MALFUNCTIONING ITEM
<p>1. Remove control valve assembly. Refer to "Control Valve Assembly and Accumulators", AT-267. 2. Check the following items:</p> <ul style="list-style-type: none"> ● Overrun clutch control valve ● Overrun clutch reducing valve ● Overrun clutch solenoid valve 	
OK or NG	
OK	▶ GO TO 5.
NG	▶ Repair or replace damaged parts.

5	CHECK SYMPTOM
Check again.	
OK or NG	
OK	▶ INSPECTION END
NG	▶ <ul style="list-style-type: none"> 1. Perform TCM input/output signal inspection. 2. If NG, recheck TCM pin terminals for damage or loose connection with harness connector.

6	DETECT MALFUNCTIONING ITEM
<p>1. Remove control valve assembly. Refer to "Control Valve Assembly and Accumulators", AT-267. 2. Check the following items:</p> <ul style="list-style-type: none"> ● Overrun clutch control valve ● Overrun clutch reducing valve ● Overrun clutch solenoid valve <p>3. Disassemble A/T. 4. Check the following items:</p> <ul style="list-style-type: none"> ● Overrun clutch assembly ● Oil pump assembly 	
OK or NG	
OK	▶ GO TO 5.
NG	▶ Repair or replace damaged parts.

GI
MA
EM
LC
EC
FE
CL
MT
AT
TF
PD
AX
SU
BR
ST
RS
BT
HA
SC
EL
IDX

TROUBLE DIAGNOSES FOR SYMPTOMS

16. Vehicle Does Not Start From D₁

16. Vehicle Does Not Start From D₁

NGAT0088

SYMPTOM:

Vehicle does not start from D₁ on Cruise test — Part 2.

1	CHECK SELF-DIAGNOSTIC RESULTS	
<p>Does self-diagnosis show damage to vehicle speed sensor-A/T (revolution sensor), shift solenoid valve A, B or vehicle speed sensor-MTR after cruise test?</p>		
SAT633I		
Yes or No		
Yes	▶	Check damaged circuit. Refer to "DTC P0720 VEHICLE SPEED SENSOR-A/T (REVOLUTION SENSOR)", AT-119, "DTC P0750 SHIFT SOLENOID VALVE A", AT-172, "DTC P0755 SHIFT SOLENOID VALVE B", AT-177, or "DTC VEHICLE SPEED SENSOR-MTR", AT-202.
No	▶	GO TO 2.

2	CHECK SYMPTOM	
Check again.		
OK or NG		
OK	▶	Go to "8. Vehicle Cannot Be Started From D ₁ ", AT-229.
NG	▶	<ol style="list-style-type: none"> 1. Perform TCM input/output signal inspection. 2. If NG, recheck TCM pin terminals for damage or loose connection with harness connector.

TROUBLE DIAGNOSES FOR SYMPTOMS

17. A/T Does Not Shift: D₄ → D₃, When Overdrive Control Switch ON → OFF

17. A/T Does Not Shift: D₄ → D₃, When Overdrive Control Switch ON → OFF

=NGAT0089

SYMPTOM:

A/T does not shift from D₄ to D₃ when changing overdrive control switch to OFF position.

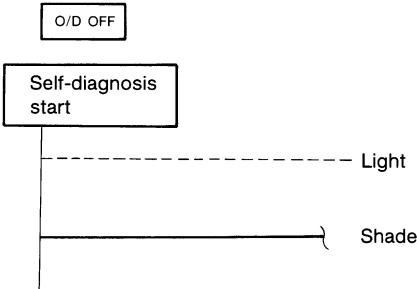
1	CHECK OVERDRIVE CONTROL SWITCH CIRCUIT	
<p><input type="checkbox"/> With CONSULT-II Does "TCM INPUT SIGNALS" in Data Monitor show damage to overdrive control switch circuit?</p>		
<p><input checked="" type="checkbox"/> Without CONSULT-II Does self-diagnosis show damage to overdrive control switch circuit?</p>		
 <pre> graph TD A[O/D OFF] --- B[Self-diagnosis start] B -.-> C[Light] B --- D[Shade] </pre>		
SAT344H		
Yes or No		
Yes	▶	Check overdrive control switch circuit. Refer to "Diagnostic Procedure", AT-253.
No	▶	Go to "10. A/T Does Not Shift: D ₂ → D ₃ ", AT-235.

GI

MA

EM

LC

EC

FE

CL

MT

AT

TF

PD

AX

SU

BR

ST

RS

BT

HA

SC

EL

IDX

TROUBLE DIAGNOSES FOR SYMPTOMS

18. A/T Does Not Shift: $D_3 \rightarrow 2_2$, When Selector Lever $D \rightarrow 2$ Position

18. A/T Does Not Shift: $D_3 \rightarrow 2_2$, When Selector Lever $D \rightarrow 2$ Position

=NGAT0090

SYMPTOM:

A/T does not shift from D_3 to 2_2 when changing selector lever from D to 2 position.

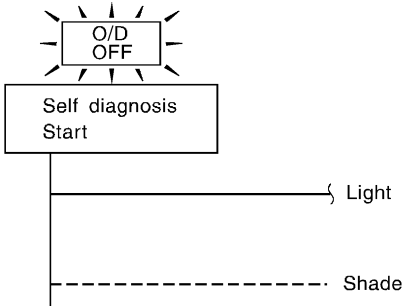
1	CHECK PNP SWITCH CIRCUIT
<p><input type="checkbox"/> With CONSULT-II Does "TCM INPUT SIGNALS" in Data Monitor show damage to PNP switch circuit?</p>	
<p><input checked="" type="checkbox"/> Without CONSULT-II Does self-diagnosis show damage to PNP switch circuit?</p> <div style="text-align: center; margin: 10px 0;">  <p>The diagram shows a box labeled 'O/D OFF' with radiating lines above it. Below it is a box labeled 'Self diagnosis Start'. A solid line connects 'Self diagnosis Start' to a bracket labeled 'Light'. A dashed line connects 'Self diagnosis Start' to a bracket labeled 'Shade'.</p> </div> <p style="text-align: right;">SAT367J</p>	
Yes or No	
Yes	▶ Check PNP switch circuit. Refer to "DIAGNOSTIC PROCEDURE", AT-107.
No	▶ Go to "9. A/T Does Not Shift: $D_1 \rightarrow D_2$ Or Does Not Kickdown: $D_4 \rightarrow D_2$ ", AT-232.

TROUBLE DIAGNOSES FOR SYMPTOMS



19. A/T Does Not Shift: 2₂ → 1₁, When Selector Lever 2 → 1 Position

19. A/T Does Not Shift: 2₂ → 1₁, When Selector Lever 2 → 1 Position

=NGAT0091

SYMPTOM:

A/T does not shift from 2₂ to 1₁ when changing selector lever from 2 to 1 position.

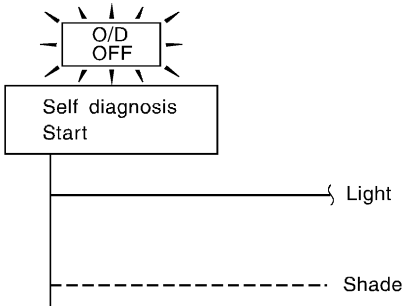
1	CHECK PNP SWITCH CIRCUIT	
<p> With CONSULT-II Does "TCM INPUT SIGNALS" in Data Monitor show damage to PNP switch circuit?</p>		
<p> Without CONSULT-II Does self-diagnosis show damage to PNP switch circuit?</p>		
		
SAT367J		
Yes or No		
Yes	▶	Check PNP switch circuit. Refer to "Diagnostic Procedure", AT-107.
No	▶	GO TO 2.

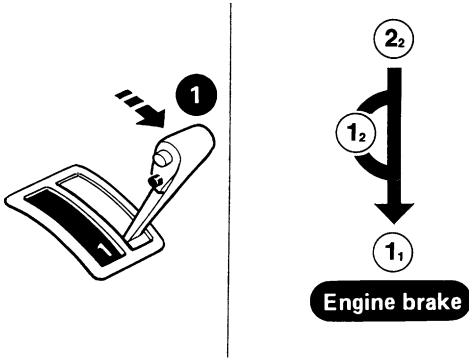
2	CHECK SYMPTOM	
Check again.		
		
OK or NG		
OK	▶	INSPECTION END
NG	▶	<ol style="list-style-type: none"> 1. Perform TCM input/output signal inspection. 2. If NG, recheck TCM pin terminals for damage or loose connection with harness connector.

TROUBLE DIAGNOSES FOR SYMPTOMS

20. Vehicle Does Not Decelerate By Engine Brake

20. Vehicle Does Not Decelerate By Engine Brake

NGAT0092

SYMPTOM:

Vehicle does not decelerate by engine brake when shifting from 2₂ (1₂) to 1₁.

1	CHECK SYMPTOM	
Is "6. Vehicle Does Not Creep Backward In R Position" OK?		
Yes or No		
Yes	▶	Go to "15. Engine Speed Does Not Return To Idle (Light Braking D ₄ → D ₃)", AT-246.
No	▶	Go to "6. Vehicle Does Not Creep Backward In R Position", AT-223.

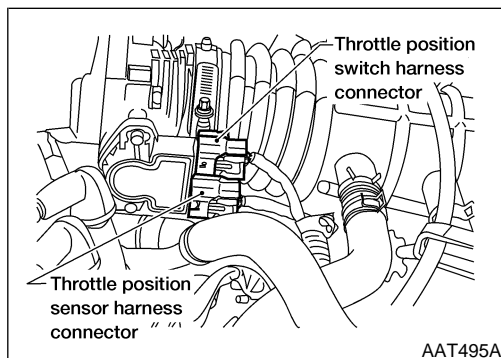
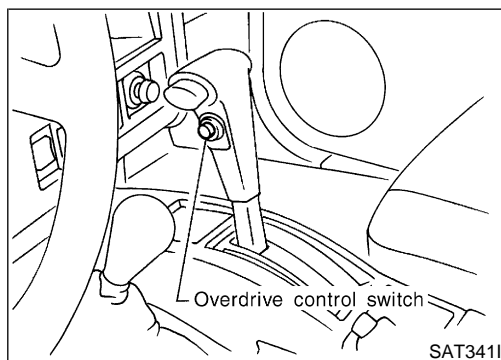
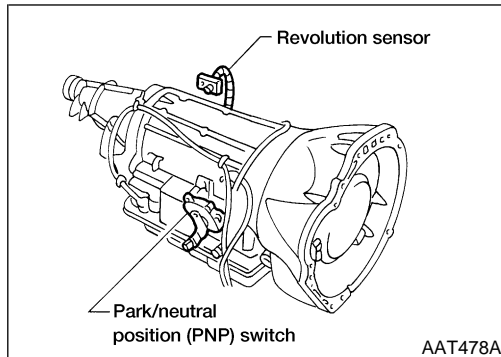

21. TCM Self-diagnosis Does Not Activate (PNP, Overdrive Control and Throttle Position Switches Circuit Checks)

NGAT0204

SYMPTOM:

O/D OFF indicator lamp does not come on in TCM self-diagnostic procedure even the lamp circuit is good.

DESCRIPTION

NGAT0204S01

- PNP switch
The PNP switch assembly includes a transmission range switch.
The transmission range switch detects the selector position and sends a signal to the TCM.
- Overdrive control switch
Detects the overdrive control switch position (ON or OFF) and sends a signal to the TCM.
- Throttle position switch
Consists of a wide open throttle position switch and a closed throttle position switch.
The wide open position switch sends a signal to the TCM when the throttle valve is open at least 1/2 of the full throttle position. The closed throttle position switch sends a signal to the TCM when the throttle valve is fully closed.

TROUBLE DIAGNOSES FOR SYMPTOMS

21. TCM Self-diagnosis Does Not Activate (PNP, Overdrive Control and Throttle Position Switches Circuit Checks) (Cont'd)

DIAGNOSTIC PROCEDURE

=NGAT0204S03

NOTE:

The diagnostic procedure includes inspections for the overdrive control and throttle position switch circuits.

1	CHECK PNP SWITCH CIRCUIT (With CONSULT-II)															
<p>With CONSULT-II</p> <ol style="list-style-type: none"> Turn ignition switch to ON position. (Do not start engine.) Select "TCM INPUT SIGNALS" in "DATA MONITOR" mode for "A/T" with CONSULT-II. Read out P, R, N, D, 2 and 1 position switches moving selector lever to each position. Check the signal of the selector lever position is indicated properly. 																
<table border="1"> <thead> <tr> <th colspan="2">DATA MONITOR</th> </tr> <tr> <th>MONITORING</th> <th></th> </tr> </thead> <tbody> <tr> <td>PN POSI SW</td> <td>OFF</td> </tr> <tr> <td>R POSITION SW</td> <td>OFF</td> </tr> <tr> <td>D POSITION SW</td> <td>OFF</td> </tr> <tr> <td>2 POSITION SW</td> <td>ON</td> </tr> <tr> <td>1 POSITION SW</td> <td>OFF</td> </tr> </tbody> </table>			DATA MONITOR		MONITORING		PN POSI SW	OFF	R POSITION SW	OFF	D POSITION SW	OFF	2 POSITION SW	ON	1 POSITION SW	OFF
DATA MONITOR																
MONITORING																
PN POSI SW	OFF															
R POSITION SW	OFF															
D POSITION SW	OFF															
2 POSITION SW	ON															
1 POSITION SW	OFF															
SAT643J																
OK or NG																
OK	▶	GO TO 3.														
NG	▶	<p>Check the following items:</p> <ul style="list-style-type: none"> PNP switch Refer to "Component Inspection", AT-258. Harness for short or open between ignition switch and PNP switch (Main harness) Harness for short or open between PNP switch and TCM (Main harness) 														

GI

MA

EM

LC

EC

FE

CL

MT

AT

TF

PD

AX

SU

BR

ST

RS

BT

HA

SC

EL

IDX

TROUBLE DIAGNOSES FOR SYMPTOMS

21. TCM Self-diagnosis Does Not Activate (PNP, Overdrive Control and Throttle Position Switches Circuit Checks) (Cont'd)

2 CHECK PNP SWITCH CIRCUIT (Without CONSULT-II)

⊗ Without CONSULT-II

1. Turn ignition switch to ON position.
(Do not start engine.)
2. Check voltage between TCM terminals (26, 27, 34, 35, 36) and ground while moving selector lever through each position.

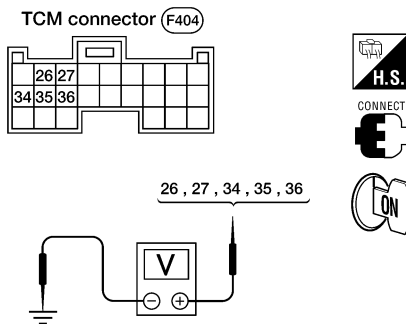
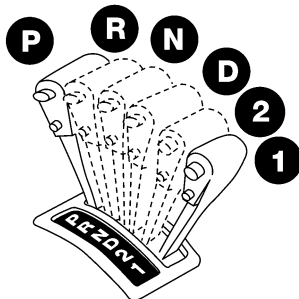

LAT457

Lever position	Terminals				
	36	35	34	27	26
P, N	B	0	0	0	0
R	0	B	0	0	0
D	0	0	B	0	0
2	0	0	0	B	0
1	0	0	0	0	B

AAT479A

Does battery voltage exist (B) or non-existent (0)?

Yes	▶	GO TO 3.
No	▶	Check the following items: <ul style="list-style-type: none"> ● PNP switch Refer to “Component Inspection”, AT-258. ● Harness for short or open between ignition switch and PNP switch (Main harness) ● Harness for short or open between PNP switch and TCM (Main harness)

TROUBLE DIAGNOSES FOR SYMPTOMS

21. TCM Self-diagnosis Does Not Activate (PNP, Overdrive Control and Throttle Position Switches Circuit Checks) (Cont'd)

3 CHECK OVERDRIVE CONTROL SWITCH CIRCUIT															
<p>Ⓜ With CONSULT-II</p> <ol style="list-style-type: none"> Turn ignition switch to ON position. (Do not start engine.) Select "TCM INPUT SIGNALS" in "DATA MONITOR" mode for "A/T" with CONSULT-II. Read out "OVERDRIVE SWITCH". Check the signal of the overdrive control switch is indicated properly. (Overdrive control switch ON displayed on CONSULT-II means overdrive OFF.) 	<table border="1" style="margin-left: auto; margin-right: auto;"> <thead> <tr> <th colspan="2">DATA MONITOR</th> </tr> <tr> <th colspan="2">MONITORING</th> </tr> </thead> <tbody> <tr> <td>ENGINE SPEED</td> <td>XXX rpm</td> </tr> <tr> <td>TURBINE REV</td> <td>XXX rpm</td> </tr> <tr> <td>OVERDRIVE SW</td> <td>ON</td> </tr> <tr> <td>PN POSI SW</td> <td>OFF</td> </tr> <tr> <td>R POSITION SW</td> <td>OFF</td> </tr> </tbody> </table> <p style="text-align: right;">SAT645J</p>	DATA MONITOR		MONITORING		ENGINE SPEED	XXX rpm	TURBINE REV	XXX rpm	OVERDRIVE SW	ON	PN POSI SW	OFF	R POSITION SW	OFF
DATA MONITOR															
MONITORING															
ENGINE SPEED	XXX rpm														
TURBINE REV	XXX rpm														
OVERDRIVE SW	ON														
PN POSI SW	OFF														
R POSITION SW	OFF														
<p>ⓧ Without CONSULT-II</p> <ol style="list-style-type: none"> Turn ignition switch to ON position. (Do not start engine.) Check voltage between TCM terminal 22 and ground when overdrive control switch is ON and OFF. 	<div style="text-align: center;"> </div> <p style="text-align: right;">AAT510A</p> <p>Voltage: Switch position ON: Battery voltage Switch position OFF: 1V or less</p> <p style="text-align: center;">OK or NG</p>														
<p>OK (With CONSULT-II) ▶</p>	<p>GO TO 4.</p>														
<p>OK (Without CONSULT-II) ▶</p>	<p>GO TO 5.</p>														
<p>NG ▶</p>	<p>Check the following items:</p> <ul style="list-style-type: none"> Overdrive control switch Refer to "Component Inspection", AT-257. Harness for short or open between TCM and overdrive control switch (Main harness) Harness for short or open of ground circuit for overdrive control switch (Main harness) 														

GI

MA

EM

LC

EC

FE

CL

MT

AT

TF

PD

AX

SU

BR

ST

RS

BT

HA

SC

EL

IDX

TROUBLE DIAGNOSES FOR SYMPTOMS

21. TCM Self-diagnosis Does Not Activate (PNP, Overdrive Control and Throttle Position Switches Circuit Checks) (Cont'd)

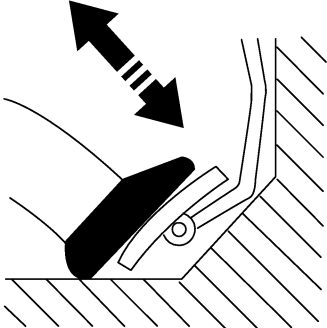
4	CHECK THROTTLE POSITION SWITCH CIRCUIT (With CONSULT-II)															
<p>Ⓜ With CONSULT-II</p> <ol style="list-style-type: none"> 1. Turn ignition switch to ON position. (Do not start engine.) 2. Select "TCM INPUT SIGNALS" in "DATA MONITOR" mode for "A/T" with CONSULT-II. 3. Read out "CLOSED THL/SW" and "W/O THRL/P-SW" depressing and releasing accelerator pedal. Check the signal of throttle position switch is indicated properly. 																
<table border="1" style="margin: auto; border-collapse: collapse;"> <thead> <tr> <th rowspan="2" style="text-align: center;">Accelerator pedal condition</th> <th colspan="2" style="text-align: center;">Data monitor</th> </tr> <tr> <th style="text-align: center;">CLOSED THL/SW</th> <th style="text-align: center;">W/O THRL/P-SW</th> </tr> </thead> <tbody> <tr> <td style="text-align: center;">Released</td> <td style="text-align: center;">ON</td> <td style="text-align: center;">OFF</td> </tr> <tr> <td style="text-align: center;">Fully depressed</td> <td style="text-align: center;">OFF</td> <td style="text-align: center;">ON</td> </tr> </tbody> </table>			Accelerator pedal condition	Data monitor		CLOSED THL/SW	W/O THRL/P-SW	Released	ON	OFF	Fully depressed	OFF	ON			
Accelerator pedal condition	Data monitor															
	CLOSED THL/SW	W/O THRL/P-SW														
Released	ON	OFF														
Fully depressed	OFF	ON														
<div style="display: flex; justify-content: space-around; align-items: center;">  <table border="1" style="margin: auto; border-collapse: collapse;"> <thead> <tr> <th colspan="2" style="text-align: center;">DATA MONITOR</th> </tr> <tr> <th style="text-align: center;">MONITORING</th> <th style="text-align: center;"></th> </tr> </thead> <tbody> <tr> <td style="text-align: center;">POWERSHIFT SW</td> <td style="text-align: center;">OFF</td> </tr> <tr> <td style="text-align: center;">CLOSED THL/SW</td> <td style="text-align: center;">OFF</td> </tr> <tr> <td style="text-align: center;">W/OTHRL/P-SW</td> <td style="text-align: center;">OFF</td> </tr> <tr> <td style="text-align: center;">HOLD SW</td> <td style="text-align: center;">OFF</td> </tr> <tr> <td style="text-align: center;">BRAKE SW</td> <td style="text-align: center;">ON</td> </tr> </tbody> </table> </div>			DATA MONITOR		MONITORING		POWERSHIFT SW	OFF	CLOSED THL/SW	OFF	W/OTHRL/P-SW	OFF	HOLD SW	OFF	BRAKE SW	ON
DATA MONITOR																
MONITORING																
POWERSHIFT SW	OFF															
CLOSED THL/SW	OFF															
W/OTHRL/P-SW	OFF															
HOLD SW	OFF															
BRAKE SW	ON															
<p>MTBL0011</p> <p>SAT646J</p>																
OK or NG																
OK	▶	GO TO 6.														
NG	▶	<p>Check the following items:</p> <ul style="list-style-type: none"> ● Throttle position switch Refer to "Component Inspection", AT-258. ● Harness for short or open between ignition switch and throttle position switch (Main harness) ● Harness for short or open between throttle position switch and TCM (Main harness) 														

TROUBLE DIAGNOSES FOR SYMPTOMS

21. TCM Self-diagnosis Does Not Activate (PNP, Overdrive Control and Throttle Position Switches Circuit Checks) (Cont'd)

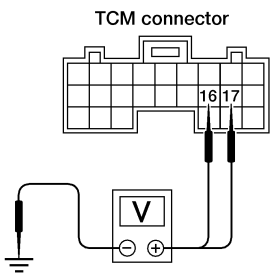
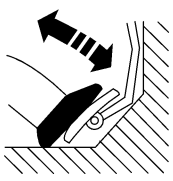
5	CHECK THROTTLE POSITION SWITCH CIRCUIT (Without CONSULT-II)												
<p>⊗ Without CONSULT-II</p> <ol style="list-style-type: none"> Turn ignition switch to ON position. (Do not start engine.) Check voltage between TCM terminals 16 (BR/W), 17 (OR/B) and ground while depressing, and releasing accelerator pedal slowly. (after warming up engine) 													
<div style="display: flex; justify-content: space-between; align-items: flex-start;"> <div style="text-align: center;">  </div> <div style="text-align: center;">  </div> <div style="text-align: center;">  </div> <div style="border: 1px solid black; padding: 5px;"> <table border="1"> <thead> <tr> <th rowspan="2">Accelerator pedal condition</th> <th colspan="2">Voltage</th> </tr> <tr> <th>Terminal No. 16</th> <th>Terminal No. 17</th> </tr> </thead> <tbody> <tr> <td>Released</td> <td>Battery voltage</td> <td>0V</td> </tr> <tr> <td>Fully Depressed</td> <td>0V</td> <td>Battery voltage</td> </tr> </tbody> </table> </div> </div>			Accelerator pedal condition	Voltage		Terminal No. 16	Terminal No. 17	Released	Battery voltage	0V	Fully Depressed	0V	Battery voltage
Accelerator pedal condition	Voltage												
	Terminal No. 16	Terminal No. 17											
Released	Battery voltage	0V											
Fully Depressed	0V	Battery voltage											
LAT329													
OK or NG													
OK	▶	GO TO 6.											
NG	▶	<p>Check the following items:</p> <ul style="list-style-type: none"> Throttle position switch Refer to "Component Inspection", AT-258. Harness for short or open between ignition switch and throttle position switch (Main harness) Harness for short or open between throttle position switch and TCM (Main harness) 											

6	CHECK DTC	
Perform Diagnostic procedure, AT-253.		
OK or NG		
OK	▶	INSPECTION END
NG	▶	<ol style="list-style-type: none"> Perform TCM input/output signal inspection. If NG, recheck TCM pin terminals for damage or loose connection with harness connector.

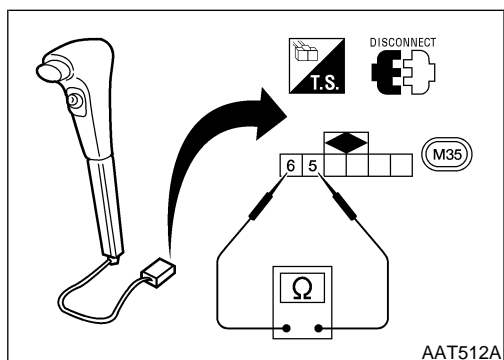

COMPONENT INSPECTION

Overdrive Control Switch

- Check continuity between terminals 5 and 6.

Continuity:

Switch position ON:

No

Switch position OFF:

Yes

NGAT0204S04

NGAT0204S0401

GI
MA
EM
LC
EC
FE
CL
MT
AT
TF
PD
AX
SU
BR
ST
RS
BT
HA
SC
EL
IDX

TROUBLE DIAGNOSES FOR SYMPTOMS

21. TCM Self-diagnosis Does Not Activate (PNP, Overdrive Control and Throttle Position Switches Circuit Checks) (Cont'd)

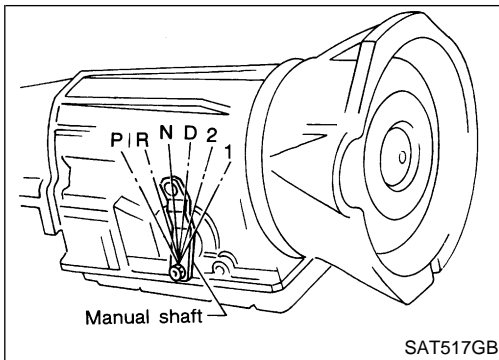

PNP Switch

NGAT0204S0402

1. Check continuity between terminals 1 and 2 and between terminals 3 and (4, 5, 6, 7, 8, 9) while moving manual shaft through each position.

Lever position	Terminal No.	
P	1 - 2	3 - 4
R		3 - 5
N	1 - 2	3 - 6
D		3 - 7
2		3 - 8
1		3 - 9

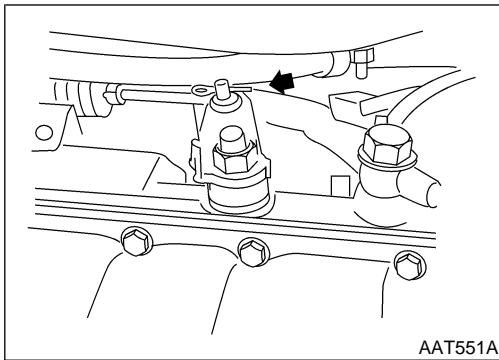
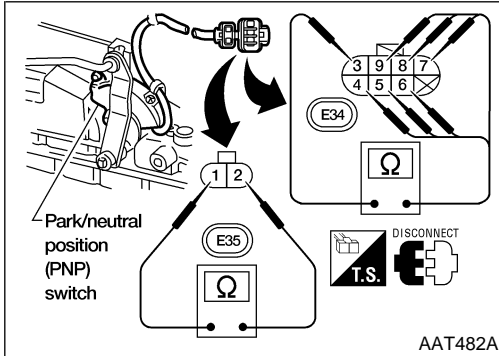

2. If NG, check again with manual control linkage disconnected from manual shaft of A/T assembly. Refer to step 1.
3. If OK on step 2, adjust manual control linkage. Refer to "Manual Control Linkage Adjustment", AT-270.

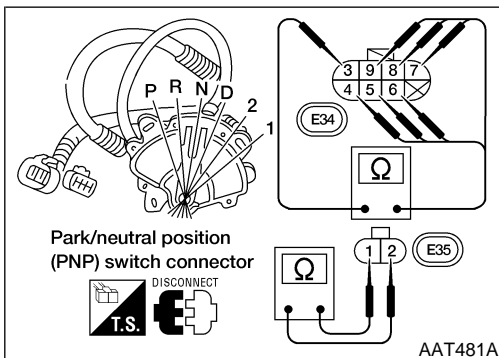

4. If NG on step 2, remove PNP switch from A/T and check continuity of PNP switch terminals. Refer to step 1.
5. If OK on step 4, adjust PNP switch. Refer to "Park/Neutral Position (PNP) Switch Adjustment", AT-270.
6. If NG on step 4, replace PNP switch.

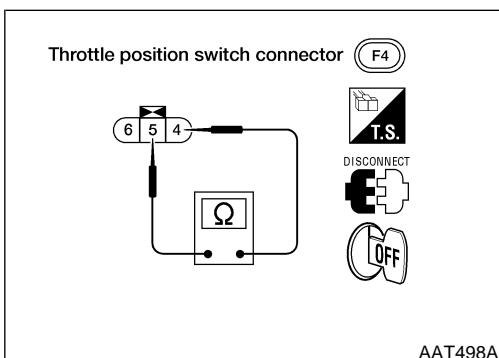

Throttle Position Switch

NGAT0204S0403

Closed Throttle Position Switch (Idle Position)

- Check continuity between terminals 4 and 5.

Accelerator pedal condition	Continuity
Released	Yes
Depressed	No

- To adjust closed throttle position switch, refer to **EC-701** (VG33E only) or **EC-1273** (VG33ER only), "Basic Inspection".

TROUBLE DIAGNOSES FOR SYMPTOMS

21. TCM Self-diagnosis Does Not Activate (PNP, Overdrive Control and Throttle Position Switches Circuit Checks) (Cont'd)

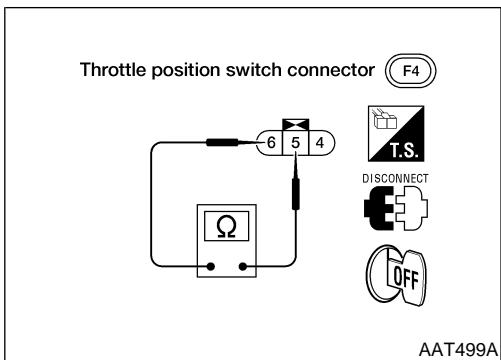

Wide Open Throttle Position Switch

- Check continuity between terminals 5 and 6.

Accelerator pedal condition	Continuity
Released	No
Depressed	Yes

GI

MA

EM

LC

EC

FE

CL

MT

AT

TF

PD

AX

SU

BR

ST

RS

BT

HA

SC

EL

IDX

A/T SHIFT LOCK SYSTEM

Description

Description

NGAT0093

- The mechanical key interlock mechanism also operates as a shift lock:
With the key switch turned to ON, the selector lever cannot be shifted from P (park) to any other position unless the brake pedal is depressed.
With the key removed, the selector lever cannot be shifted from P to any other position.
The key cannot be removed unless the selector lever is placed in P.
- The shift lock and key interlock mechanisms are controlled by the ON-OFF operation of the shift lock solenoid and by the operation of the rotator and slider located inside the key cylinder, respectively.

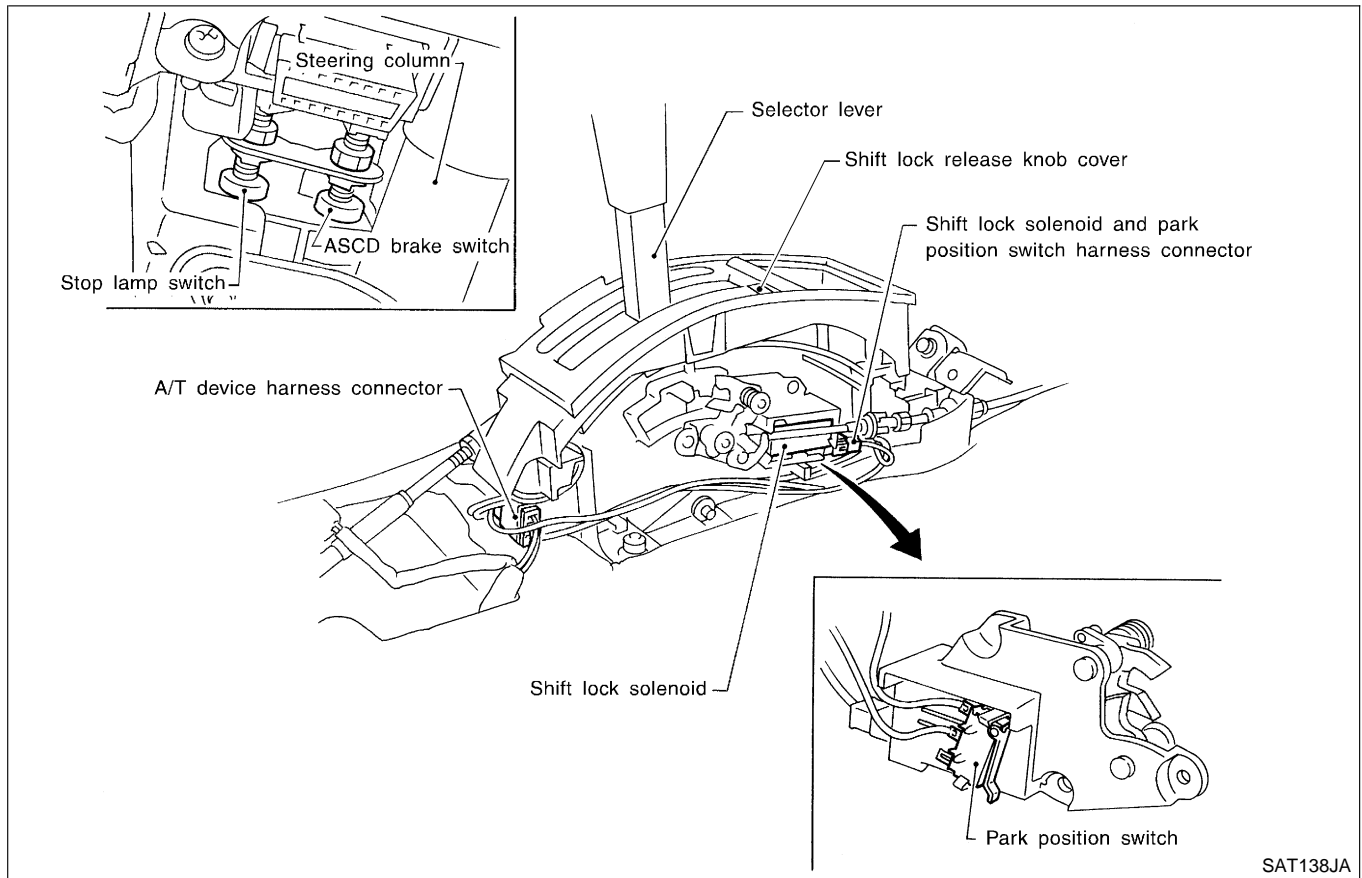

A/T SHIFT LOCK SYSTEM

Wiring Diagram — SHIFT —

Wiring Diagram — SHIFT —

NGAT0094

AT-SHIFT-01

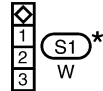
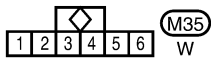
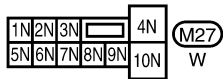
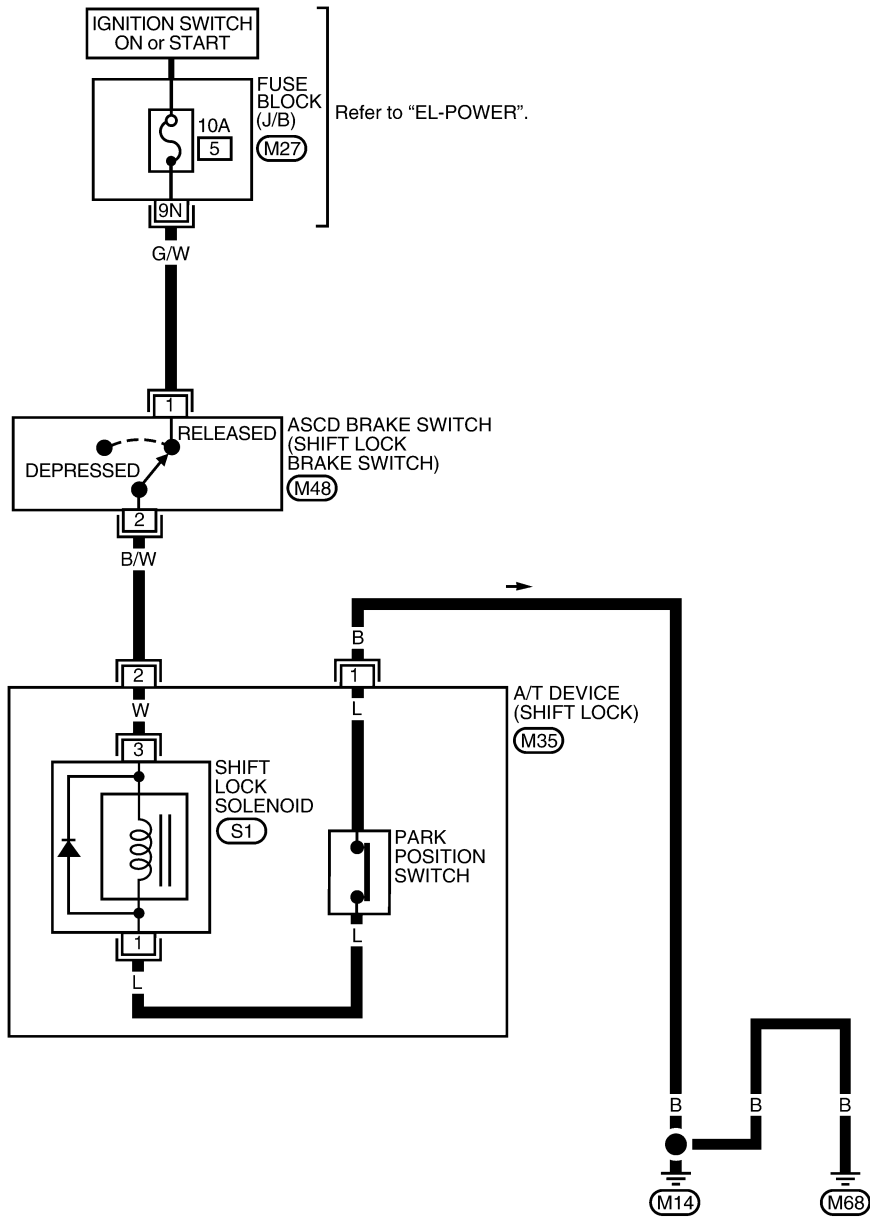

* : This connector is not shown in "HARNESS LAYOUT" of EL section.

WAT490

GI
MA
EM
LC
EC
FE
CL
MT
AT
TF
PD
AX
SU
BR
ST
RS
BT
HA
SC
EL
IDX

A/T SHIFT LOCK SYSTEM

Diagnostic Procedure

Diagnostic Procedure

NGAT0095

SYMPTOM 1:

- Selector lever cannot be moved from P position with key in ON position and brake pedal applied.
- Selector lever can be moved from P position with key in ON position and brake pedal released.
- Selector lever can be moved from P position when key is removed from key cylinder.

SYMPTOM 2:

Ignition key cannot be removed when selector lever is set to P position. It can be removed when selector lever is set to any position except P.



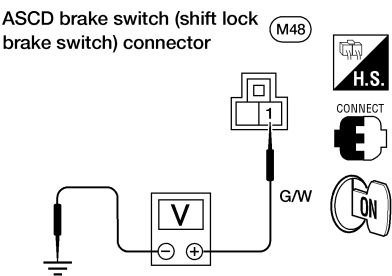

1	CHECK KEY INTERLOCK CABLE
Check key interlock cable for damage.	
OK or NG	
OK	▶ GO TO 2.
NG	▶ Repair key interlock cable. Refer to "Key Interlock Cable", AT-265.



2	CHECK SELECTOR LEVER POSITION
Check selector lever position for damage.	
OK or NG	
OK	▶ GO TO 3.
NG	▶ Check selector lever. Refer to "Park/Neutral Position (PNP) Switch Adjustment", AT-270 and "Manual Control Linkage Adjustment", AT-270.

3	CHECK POWER SOURCE
<p>1. Turn ignition switch to ON position. (Do not start engine.)</p> <p>2. Check voltage between ASCD brake switch (shift lock brake switch) connector</p>	
 <p>ASCD brake switch (shift lock brake switch) connector</p> <p>M48</p> <p>H.S.</p> <p>CONNECT</p> <p>G/W</p> <p>ON</p>	
AAT513A	
Does battery voltage exist?	
Yes	▶ GO TO 4.
No	▶ Check the following items: <ul style="list-style-type: none"> • Harness for short or open between battery and ASCD brake switch (shift lock brake switch) harness terminal 1 • Fuse • Ignition switch Refer to EL-10 , "POWER SUPPLY ROUTING".

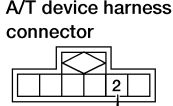
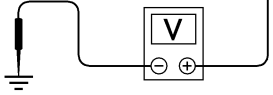
A/T SHIFT LOCK SYSTEM

Diagnostic Procedure (Cont'd)

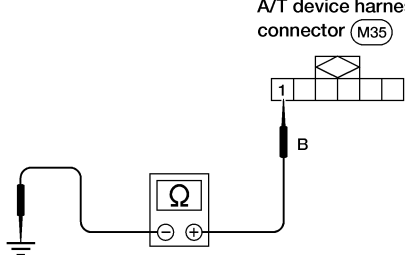
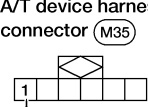
4	CHECK INPUT SIGNAL (BRAKE SWITCH)	
<p>Turn ignition switch to ON position. (Do not start engine.)</p> <ul style="list-style-type: none"> Check voltage between A/T device harness connector M35 terminal 2 (B/W) and ground. 		
<div style="display: flex; justify-content: space-between; align-items: flex-start;"> <div style="text-align: center;">  </div> <div style="text-align: center;">  </div> <div style="text-align: center;">  <p>A/T device harness connector</p> </div> <div style="text-align: center;">  </div> <div style="text-align: center;">  </div> </div> <p style="text-align: right;">Voltage: Brake pedal is depressed: 0V Brake pedal is released: Battery voltage</p>		
LAT330		
OK or NG		
OK	▶	GO TO 5.
NG	▶	<p>Check the following items:</p> <ul style="list-style-type: none"> Harness for short or open between A/T device harness connector 2 and ASCD brake switch (shift lock brake switch) harness connector 2 ASCD brake switch (shift lock brake switch) <p>Refer to "Component Check", AT-264.</p>

5	CHECK GROUND CIRCUIT	
<ol style="list-style-type: none"> Turn ignition switch to OFF position. Disconnect A/T device harness connector. Check continuity between A/T device harness terminal 1 and ground. 		
<div style="display: flex; justify-content: space-between; align-items: center;"> <div style="text-align: center;">  </div> <div style="text-align: center;">  <p>A/T device harness connector (M35)</p> </div> <div style="text-align: center;">  </div> </div> <p style="text-align: right;">AAT515A</p>		
OK or NG		
OK	▶	GO TO 6.
NG	▶	Repair harness or connector.

6	CHECK PARK POSITION SWITCH	
Refer to "Component Check", AT-264.		
OK or NG		
OK	▶	GO TO 7.
NG	▶	Replace park position switch.

GI
MA
EM
LC
EC
FE
CL
MT
AT
TF
PD
AX
SU
BR
ST
RS
BT
HA
SC
EL
IDX

A/T SHIFT LOCK SYSTEM

Diagnostic Procedure (Cont'd)

7	CHECK SHIFT LOCK SOLENOID
Refer to "Component Check", AT-264.	
OK or NG	
OK	▶ GO TO 8.
NG	▶ Replace shift lock solenoid.

8	CHECK SHIFT LOCK OPERATION
1. Reconnect shift lock harness connector. 2. Turn ignition switch from OFF to ON" position. (Do not start engine.) 3. Recheck shift lock operation.	
OK or NG	
OK	▶ INSPECTION END
NG	▶ 1. Perform A/T device input/output signal inspection test. ▶ 2. If NG, recheck harness connector connection.

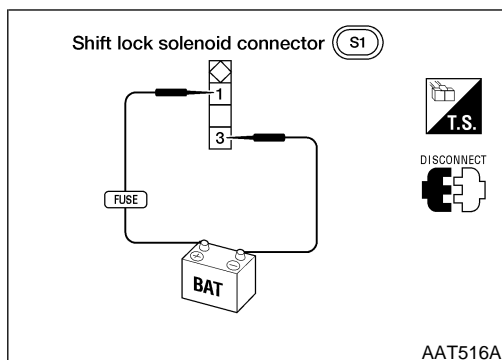

Component Check SHIFT LOCK SOLENOID

NGAT0096

NGAT0096S01

- Check operation by applying battery voltage between shift lock solenoid connector terminals 1 and 3.

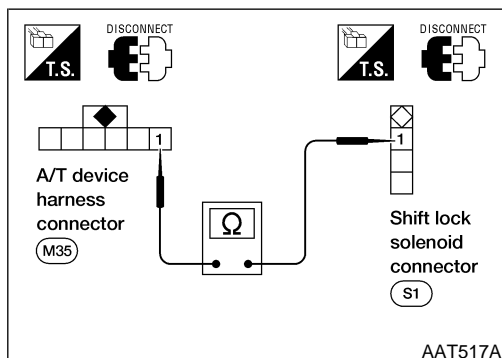

PARK POSITION SWITCH

NGAT0096S02

- Check continuity between A/T device (park position switch) harness connector terminal 1 and A/T device harness connector terminal 1.

Condition	Continuity
When selector lever is set in "P" position and selector lever button is released	Yes
Except above	No

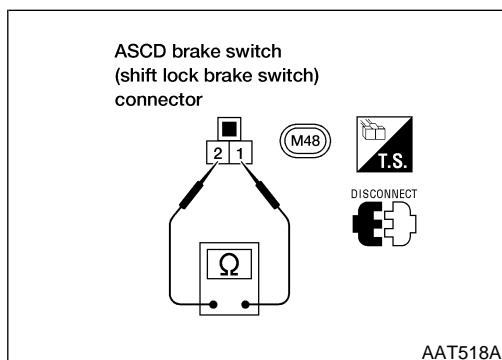

ASCD BRAKE SWITCH (SHIFT LOCK BRAKE SWITCH)

NGAT0096S03

- Check continuity between ASCD brake switch (shift lock brake switch) harness connector terminals 1 and 2.

Condition	Continuity
When brake pedal is depressed	No
When brake pedal is released	Yes

Check ASCD brake switch (shift lock brake switch) after adjusting brake pedal — refer to BR-12, "Adjustment".

Components

NGAT0097

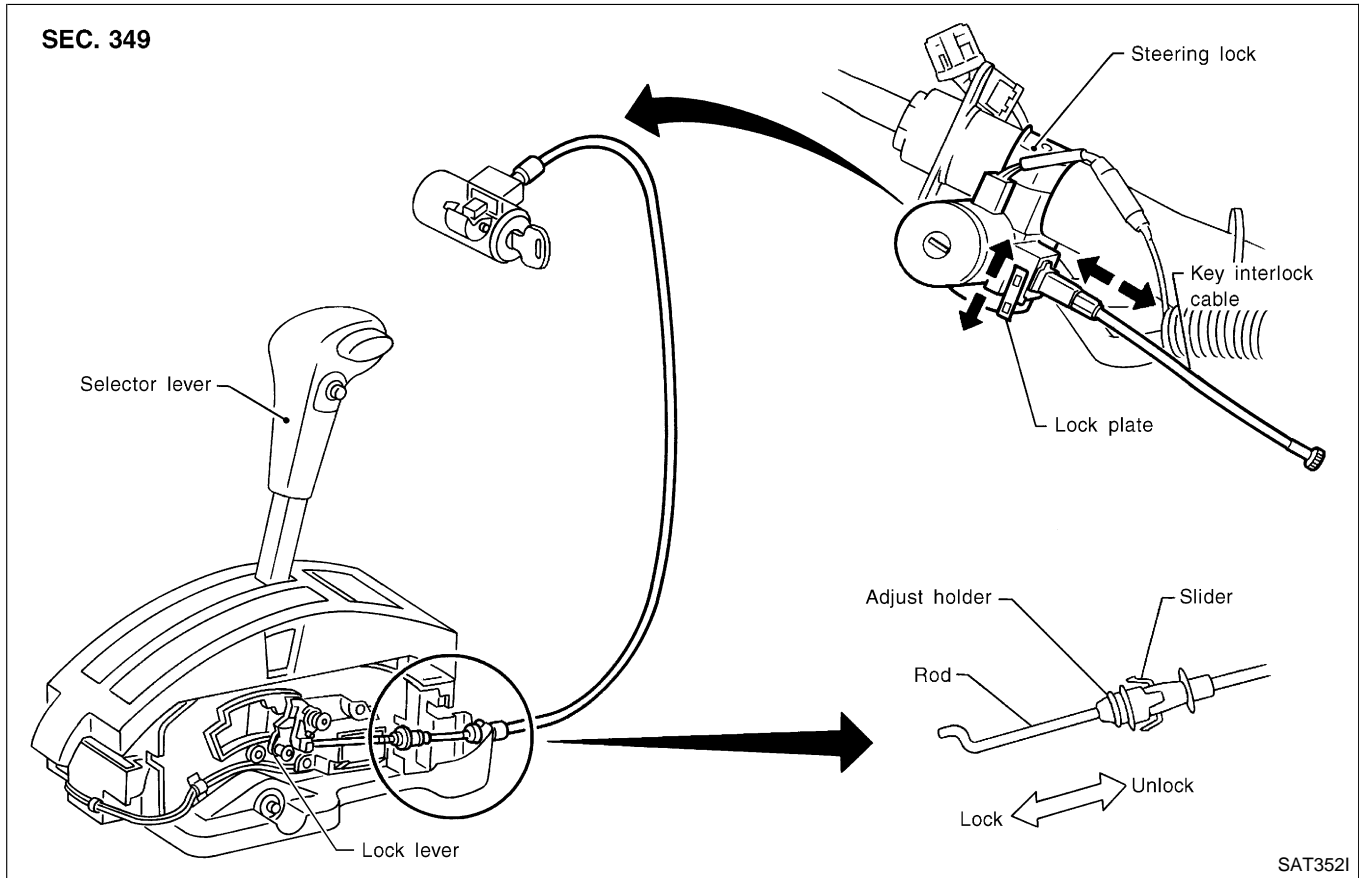

CAUTION:

- Install key interlock cable in such a way that it will not be damaged by sharp bends, twists or interference with adjacent parts.
- After installing key interlock cable to control device, make sure that casing cap and bracket are firmly secured in their positions. If casing cap can be removed with an external load of less than 39.2 N (4.0 kg, 8.8 lb), replace key interlock cable with new one.

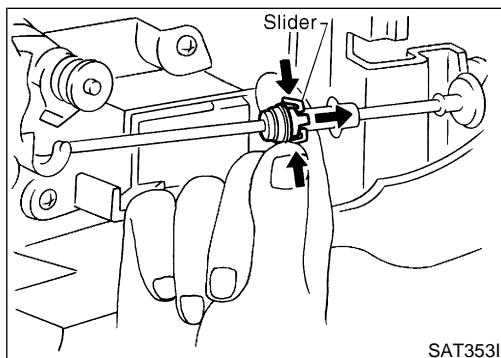

Removal

Unlock slider from adjuster holder and remove rod from cable.

NGAT0098

KEY INTERLOCK CABLE

Installation

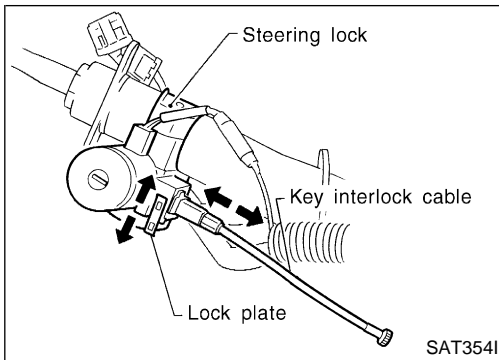

Installation

1. Set key interlock cable to steering lock assembly and install lock plate. NGAT0099
2. Clamp cable to steering column and fix to control cable with band.
3. Set selector lever to P position.

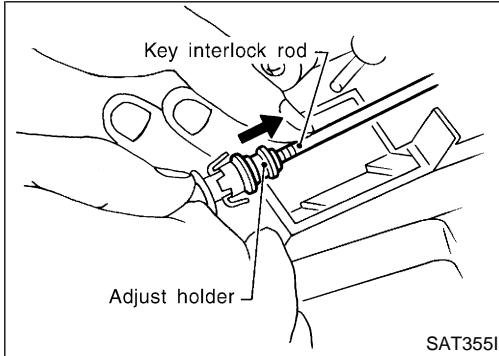

4. Insert interlock rod into adjuster holder.

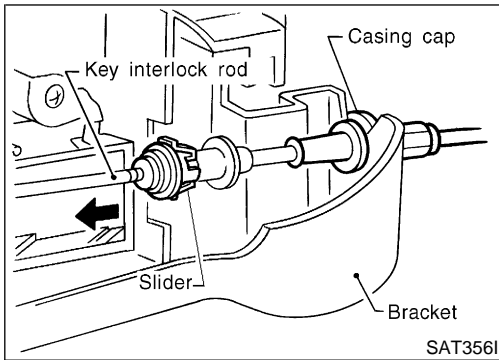

5. Install casing cap to bracket.
6. Move slider in order to fix adjuster holder to interlock rod.

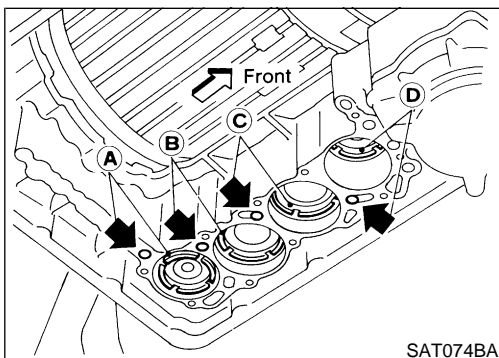
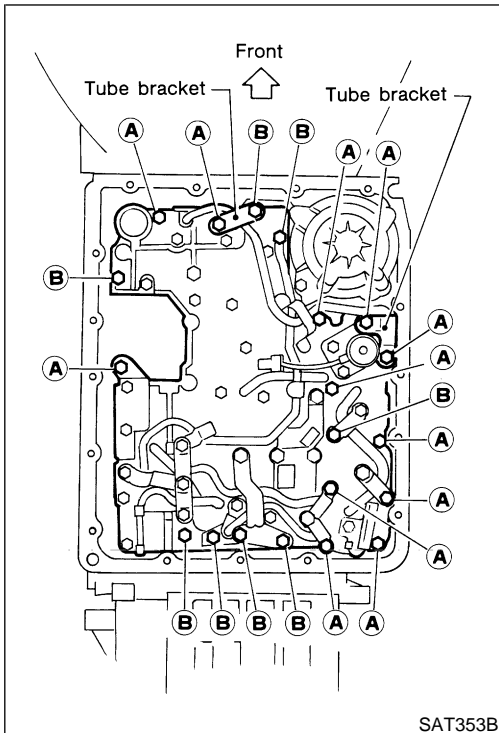
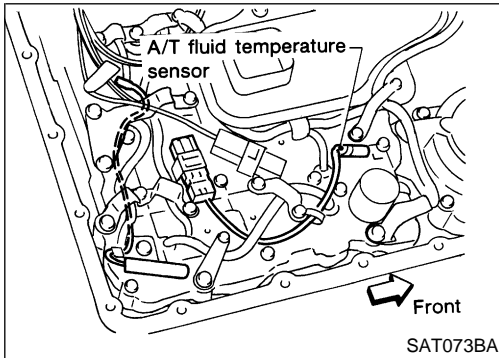
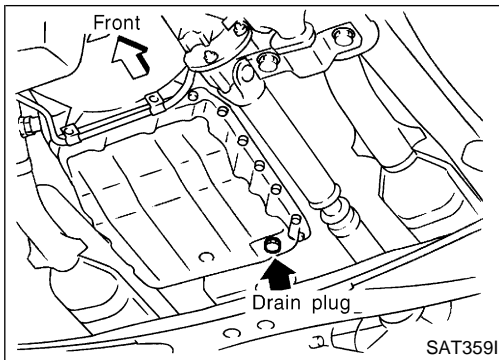

Control Valve Assembly and Accumulators

NGAT0100

NGAT0100S01

REMOVAL

1. Drain ATF through drain plug.
2. Remove exhaust front tube.
3. Remove oil pan and gasket.
- **Always replace oil pan bolts as they are self-sealing bolts.**

4. Remove A/T fluid temperature sensor if necessary.
5. Remove oil strainer.

6. Remove control valve assembly by removing fixing bolts and disconnecting harness connector.

Bolt length and location

Bolt symbol	ℓ mm (in)	
		ℓ
A		33 (1.30)
B		45 (1.77)

7. Remove solenoids and valves from valve body if necessary.
8. Remove terminal cord assembly if necessary.

9. Remove accumulator A, B, C and D by applying compressed air if necessary.

- **Hold each piston with rag.**
- 10. Reinstall any part removed.
- **Always use new sealing parts.**
- **Always replace oil pan bolts as they are self-sealing bolts.**

GI
MA
EM
LC
EC
FE
CL
MT
AT
TF
PD
AX
SU
BR
ST
RS
BT
HA
SC
EL
IDX

ON-VEHICLE SERVICE

Revolution Sensor Replacement

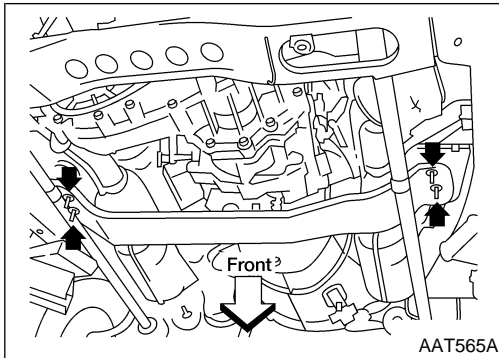

Revolution Sensor Replacement

NGAT0101

—4WD MODEL—

NGAT0101S01

1. Remove rear engine mounting member from side member while supporting A/T with transfer case with jack. Tighten rear engine mounting member to the specified torque. Refer to **EM-113**, "ENGINE REMOVAL".
 2. Lower A/T with transfer case as much as possible.
 3. Remove revolution sensor from A/T.
 4. Reinstall any part removed.
- **Always use new sealing parts.**

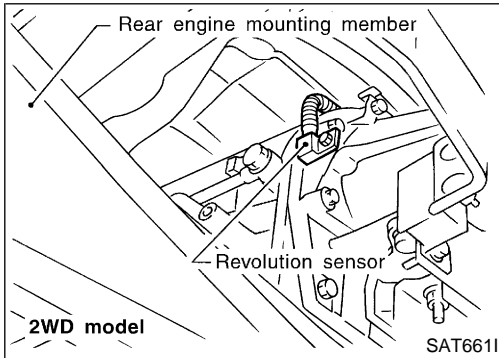

—2WD MODEL—

NGAT0101S02

- Remove revolution sensor from A/T.
- **Always use new sealing parts.**

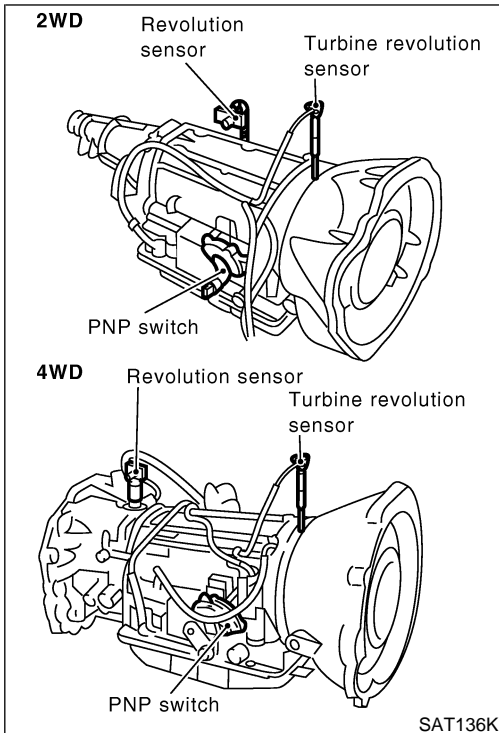

Turbine Revolution Sensor Replacement (VG33ER only)

NGAT0219

1. Remove A/T assembly. Refer to "Removal", AT-271.
 2. Remove turbine revolution sensor from A/T assembly upper side.
 3. Reinstall any part removed.
- **Always use new sealing parts.**

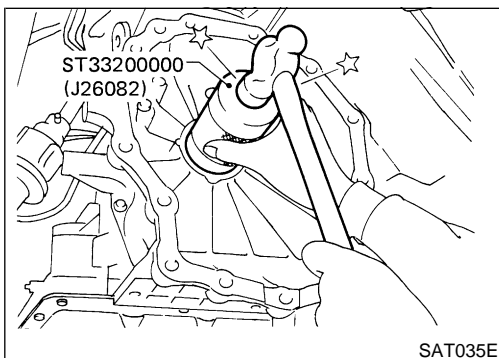

Rear Oil Seal Replacement

NGAT0102

—4WD MODEL—

NGAT0102S01

1. Remove transfer case from vehicle. Refer to **TF-10**, "Removal".
 2. Remove rear oil seal.
 3. Install rear oil seal.
- **Apply ATF before installing.**
4. Reinstall any part removed.

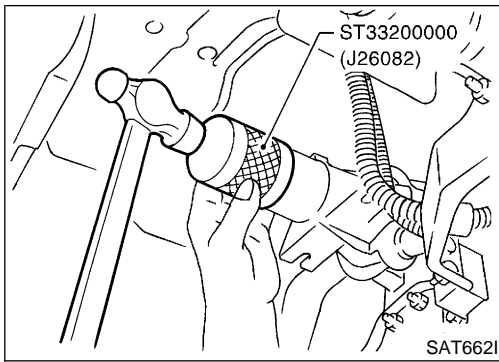

—2WD MODEL—

- 1) Remove propeller shaft from vehicle. Refer to **PD-8**, "Removal".
- 2) Remove rear oil seal.
- 3) Install rear oil seal.
- **Apply ATF before installing.**
- 4) Reinstall any part removed.

NGAT0102S02

GI
MA
EM
LC

Parking Components Inspection

—4WD MODEL—

1. Remove propeller shaft. Refer to **PD-8**, "Removal".

NGAT0103

NGAT0103S01

EC
FE
CL
MT

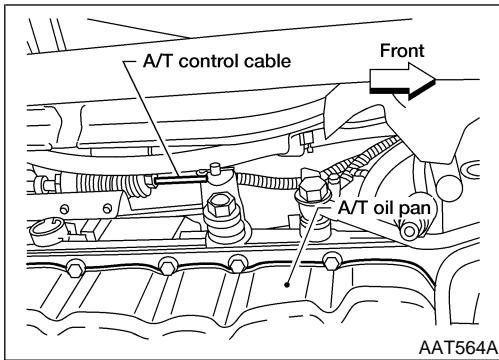

2. Remove transfer case from vehicle. Refer to **TF-10**, "Removal".
3. Remove A/T control cable bracket from transmission case.

AT

TF

PD

AX

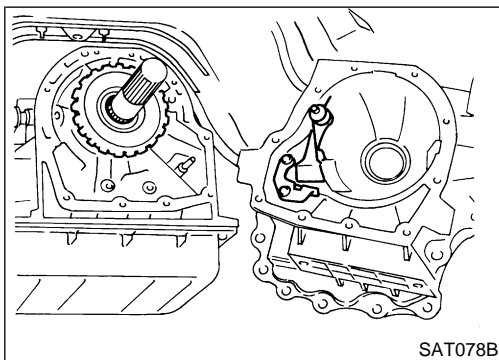

4. Support A/T assembly with a jack.
5. Remove adapter case from transmission case.
6. Replace parking components if necessary.
7. Reinstall any part removed.
- **Always use new sealing parts.**

SU

BR

—2WD MODEL—

- 1) Remove propeller shaft from vehicle. Refer to **PD-8**, "Removal".
- 2) Support A/T assembly with jack.
- 3) Remove rear engine mounting member. Tighten rear engine mounting member to the specified torque. Refer **EM-113**, "ENGINE REMOVAL".
- 4) Remove rear extension from transmission case.
- 5) Replace parking components if necessary.
- 6) Reinstall any part removed.
- **Always use new sealing parts.**

NGAT0103S02

ST

RS

BT

HA

SC

EL

IDX

ON-VEHICLE SERVICE

Park/Neutral Position (PNP) Switch Adjustment

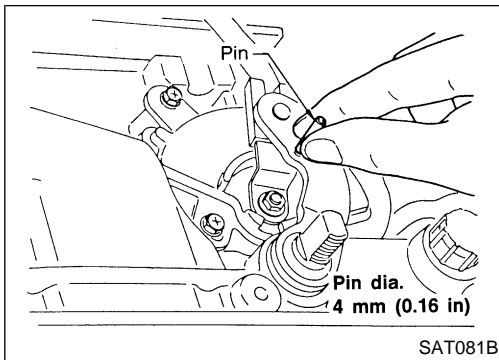

Park/Neutral Position (PNP) Switch Adjustment ^{NGAT0104}

1. Remove manual control linkage from manual shaft of A/T assembly.
2. Set manual shaft of A/T assembly in N position.
3. Loosen park/neutral position (PNP) switch fixing bolts.
4. Insert pin into adjustment holes in both park/neutral position (PNP) switch and manual shaft of A/T assembly as near vertical as possible.
5. Reinstall any part removed.
6. Check continuity of park/neutral position (PNP) switch. Refer to "Components Inspection", AT-109.

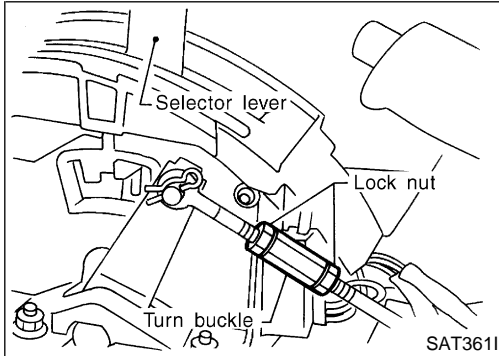

Manual Control Linkage Adjustment ^{NGAT0105}

Move selector lever from P position to 1 position. You should be able to feel the detents in each position. If the detents cannot be felt or the pointer indicating the position is improperly aligned, the linkage needs adjustment.

1. Place selector lever in P position.
2. Loosen lock nuts.
3. Tighten turn buckle until aligns with inner cable, pulling selector lever toward R position side without pushing button.
4. Back off turn buckle 1 turn and tighten lock nuts to the specified torque.
5. Move selector lever from P position to 1 position. Make sure that selector lever can move smoothly.

Lock nut:

 : 4.4 - 5.9 N·m (0.45 - 0.60 kg-m, 39.1 - 52.1 in-lb)

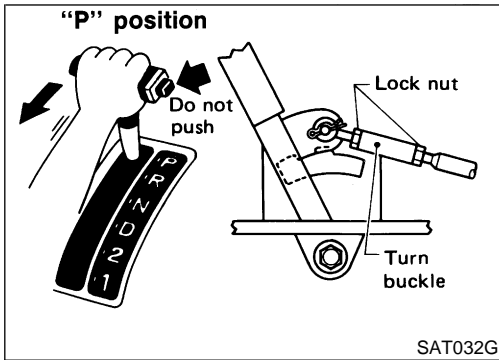

REMOVAL AND INSTALLATION

Removal

Removal —4WD MODEL—

NGAT0106

NGAT0106S01

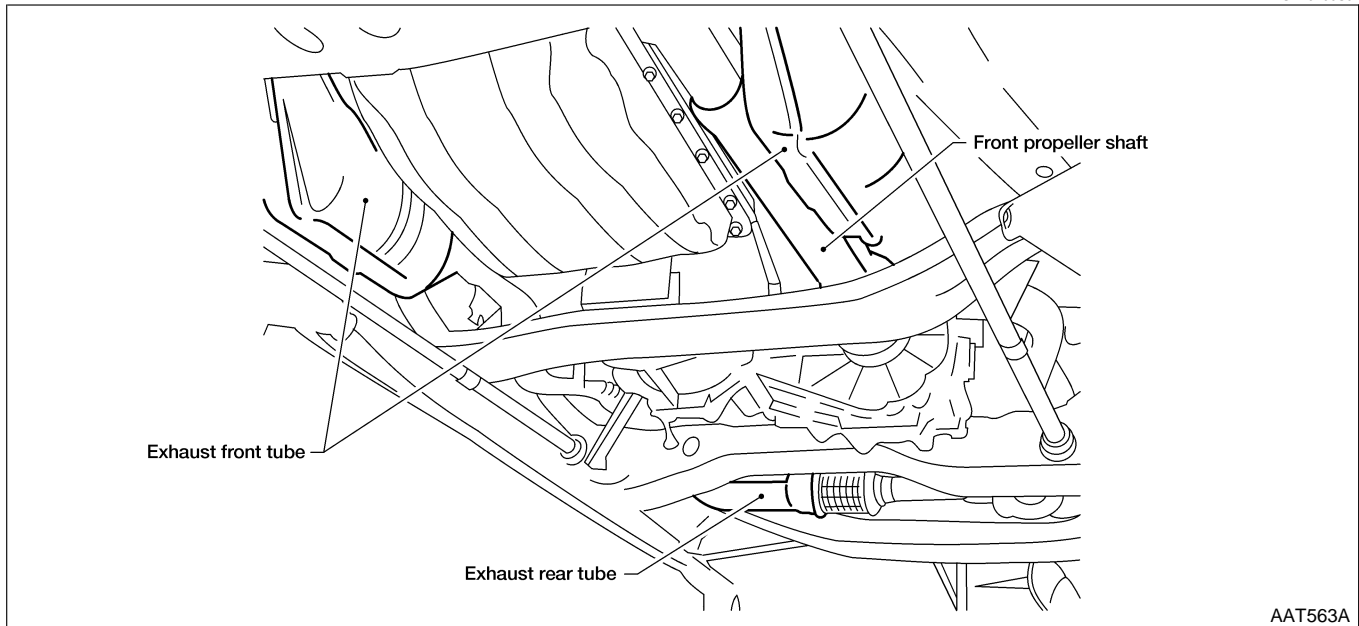

GI
MA
EM
LC
EC
FE
CL
MT

CAUTION:

When removing the A/T assembly from engine, first remove the crankshaft position sensor (OBD) from the A/T assembly upper side.

Be careful not to damage sensor edge.

1. Remove battery negative terminal.
 2. Remove exhaust front and rear tubes.
 3. Remove fluid charging pipe from A/T assembly.
 4. Remove oil cooler pipe from A/T assembly.
 5. Plug up openings such as the fluid charging pipe hole, etc.
 6. Remove propeller shaft. Refer to **PD-8**, "Removal".
 7. Remove transfer control linkage from transfer. Refer to **TF-10**, "Removal".
- Insert plug into rear oil seal after removing rear propeller shaft.
 - Be careful not to damage spline, sleeve yoke and rear oil seal.
8. Remove A/T control cable from A/T assembly.
 9. Disconnect A/T, turbine revolution sensor (VG33ER only) and vehicle speed sensor harness connectors.

AT
TF
PD
AX
SU
BR
ST
RS

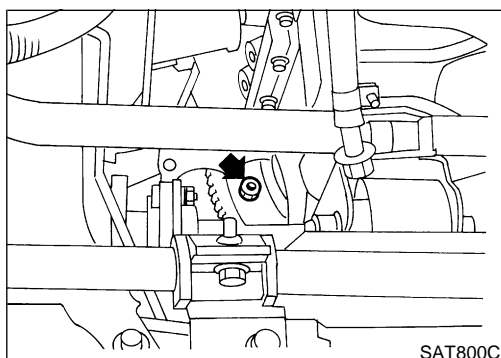

10. Remove starter motor.
Tightening torque:
Refer to SC-25, "VG33E MODELS".
11. Remove gusset (if equipped) and rear plate cover securing engine to A/T assembly.
12. Remove bolts securing torque converter to drive plate.
 - Remove the bolts by turning crankshaft.

BT
HA
SC
EL
IDX

REMOVAL AND INSTALLATION

Removal (Cont'd)

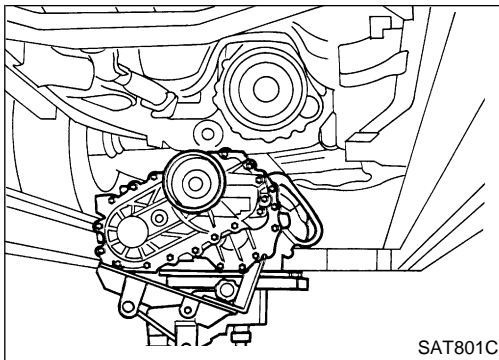

13. Support A/T and transfer assembly with a jack.
14. Remove rear engine mounting member from body and A/T assembly. Tighten rear engine mounting member to the specified torque. Refer to **EM-113**, "ENGINE REMOVAL".
15. Remove bolts securing A/T assembly to engine.
16. Lower A/T assembly with transfer.

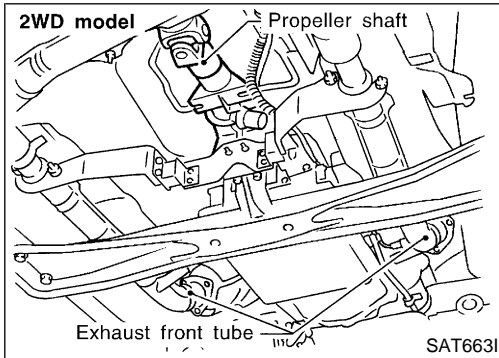

—2WD MODEL—

NGAT0106S02

1. Remove battery negative terminal.
 2. Remove exhaust front and rear tubes.
 3. Remove fluid charging pipe from A/T assembly.
 4. Remove oil cooler pipe from A/T assembly.
 5. Plug up openings such as the fluid charging pipe hole, etc.
 6. Remove propeller shaft. Refer to **PD-8**, "Removal".
 7. Remove transfer control linkage from transfer. Refer to **TF-10**, "Removal".
- **Insert plug into rear oil seal after removing rear propeller shaft.**
 - **Be careful not to damage spline, sleeve yoke and rear oil seal.**
8. Remove A/T control cable from A/T assembly.
 9. Disconnect A/T, turbine revolution sensor (VG33ER only) and vehicle speed sensor harness connectors.
 10. Remove starter motor.

Tightening torque:

Refer to **SC-25**, "VG33E AND VG33ER MODELS".

11. Remove gusset and rear plate cover securing engine to A/T assembly.
12. Remove bolts securing torque converter to drive plate.
- **Remove the bolts by turning crankshaft.**
13. Support A/T assembly with a jack.
14. Remove rear engine mounting member from body and A/T assembly. Tighten rear engine mounting member to the specified torque. Refer to **EM-113**, "ENGINE REMOVAL".
15. Remove bolts securing A/T assembly to engine.
16. Pull A/T assembly backwards.
- **Secure torque converter to prevent it from dropping.**
- **Secure A/T assembly to a jack.**
17. Lower A/T assembly.

Installation

NGAT0107

- Drive plate runout
 - Maximum allowable runout:
Refer to **EM-124**, "FLYWHEEL/DRIVE PLATE RUNOUT".

If this runout is out of specification, replace drive plate with ring gear.

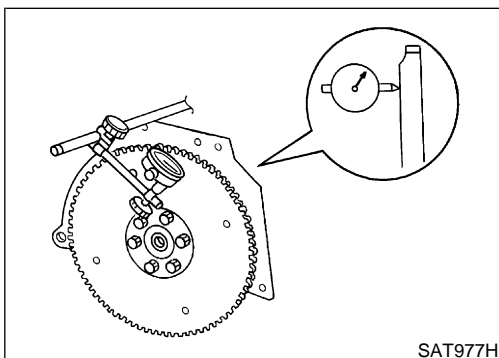

REMOVAL AND INSTALLATION

Installation (Cont'd)

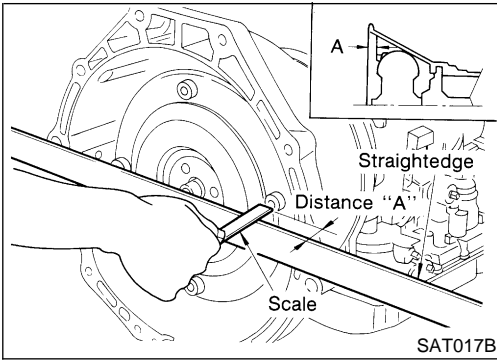

- When connecting torque converter to transmission, measure distance "A" to be certain that they are correctly assembled.

Distance "A":

VG33E only: 26.0 mm (1.024 in) or more

VG33ER only: 25.0 mm (0.984 in) or more

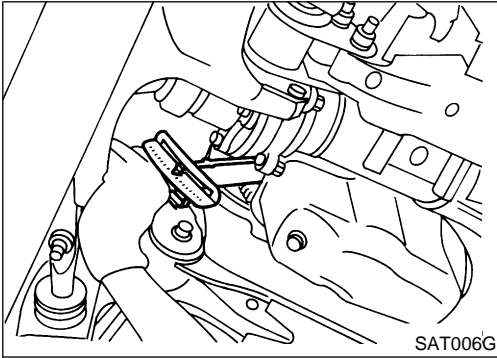

- Install converter to drive plate.
- After converter is installed to drive plate, rotate crankshaft several turns and check to be sure that transmission rotates freely without binding.**

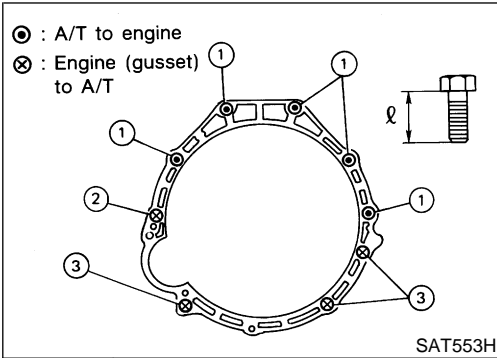

- Tighten bolts securing transmission.

Bolt No.	Tightening torque N-m (kg-m, ft-lb)	Bolt length "l" mm (in)
1	39 - 49 (4.0 - 5.0, 29 - 36)	47.5 (1.870)
2	39 - 49 (4.0 - 5.0, 29 - 36)	58.0 (2.283)
3	29 - 39 (3.0 - 4.0, 22 - 29)	25.0 (0.984)
Gusset (if equipped) to engine	29 - 39 (3.0 - 4.0, 22 - 29)	20.0 (0.787)

- Reinstall any part removed.

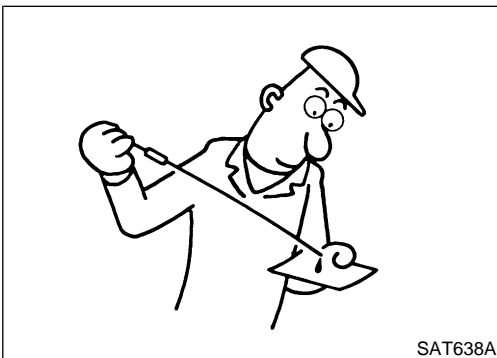

- Check fluid level in transmission.
- Move selector lever through all positions to be sure that transmission operates correctly. With parking brake applied, rotate engine at idling. Move selector lever through N to D, to 2, to 1 and to R positions. A slight shock should be felt by hand gripping selector each time transmission is shifted.
- Perform road test. Refer to "Road Test", AT-66.

GI
MA
EM
LC
EC
FE
CL
MT
AT
TF
PD
AX
SU
BR
ST
RS
BT
HA
SC
EL
IDX

OVERHAUL

Components

SEC. 311•313•315

- : N•m (kg-m, ft-lb)
- : Apply Genuine Anaerobic Liquid Gasket or equivalent. Refer to GI Section.
- : Apply ATF.
- (P) : Apply petroleum jelly.
- ★ : Select with proper thickness.

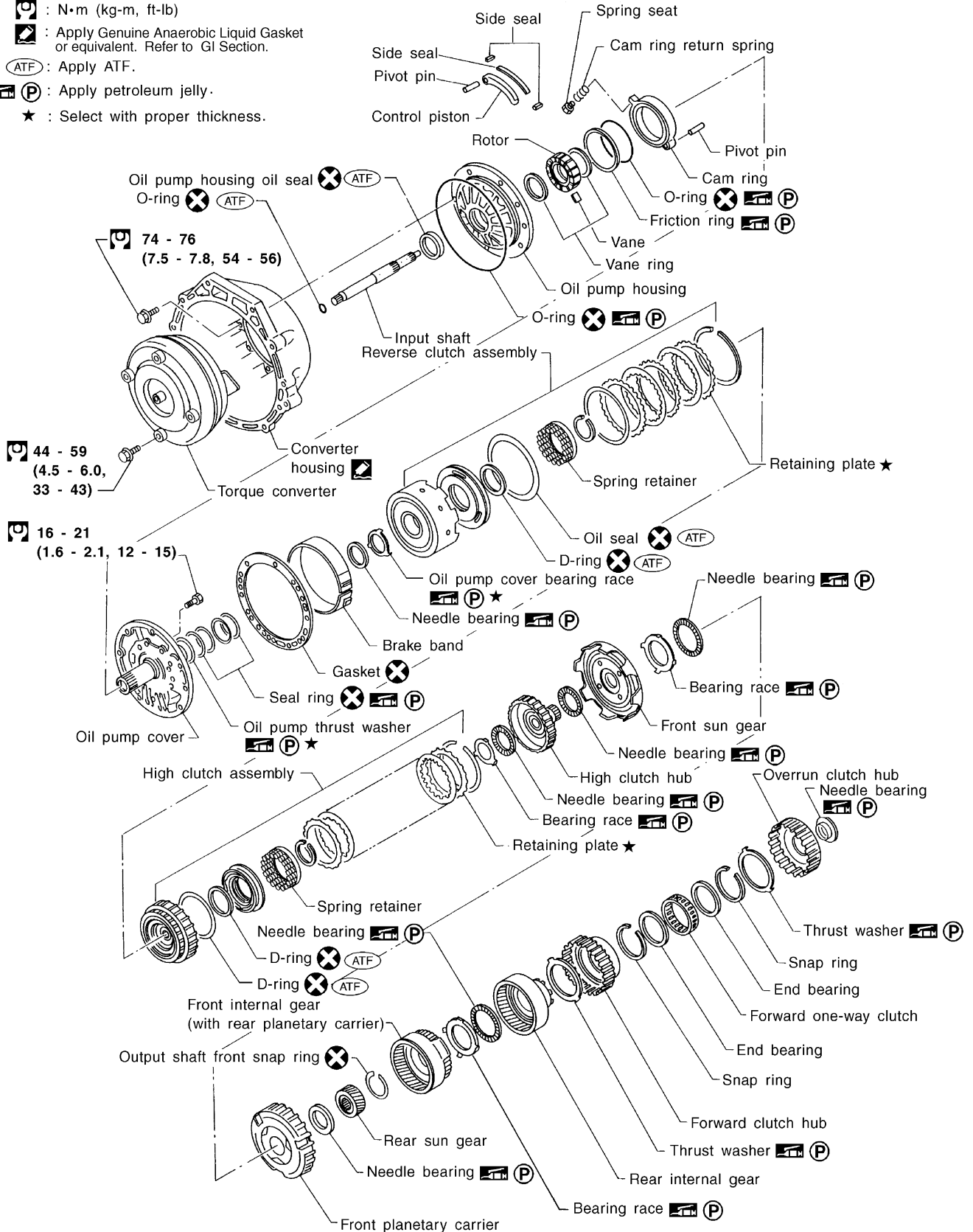

OVERHAUL

Components (Cont'd)

SEC. 311 • 315 • 317

: N·m (kg-m, in-lb)

: N·m (kg-m, ft-lb)

: Apply ATF.

(P) : Apply petroleum jelly.

★ : Select with proper thickness.

☆ : Adjustment is required.

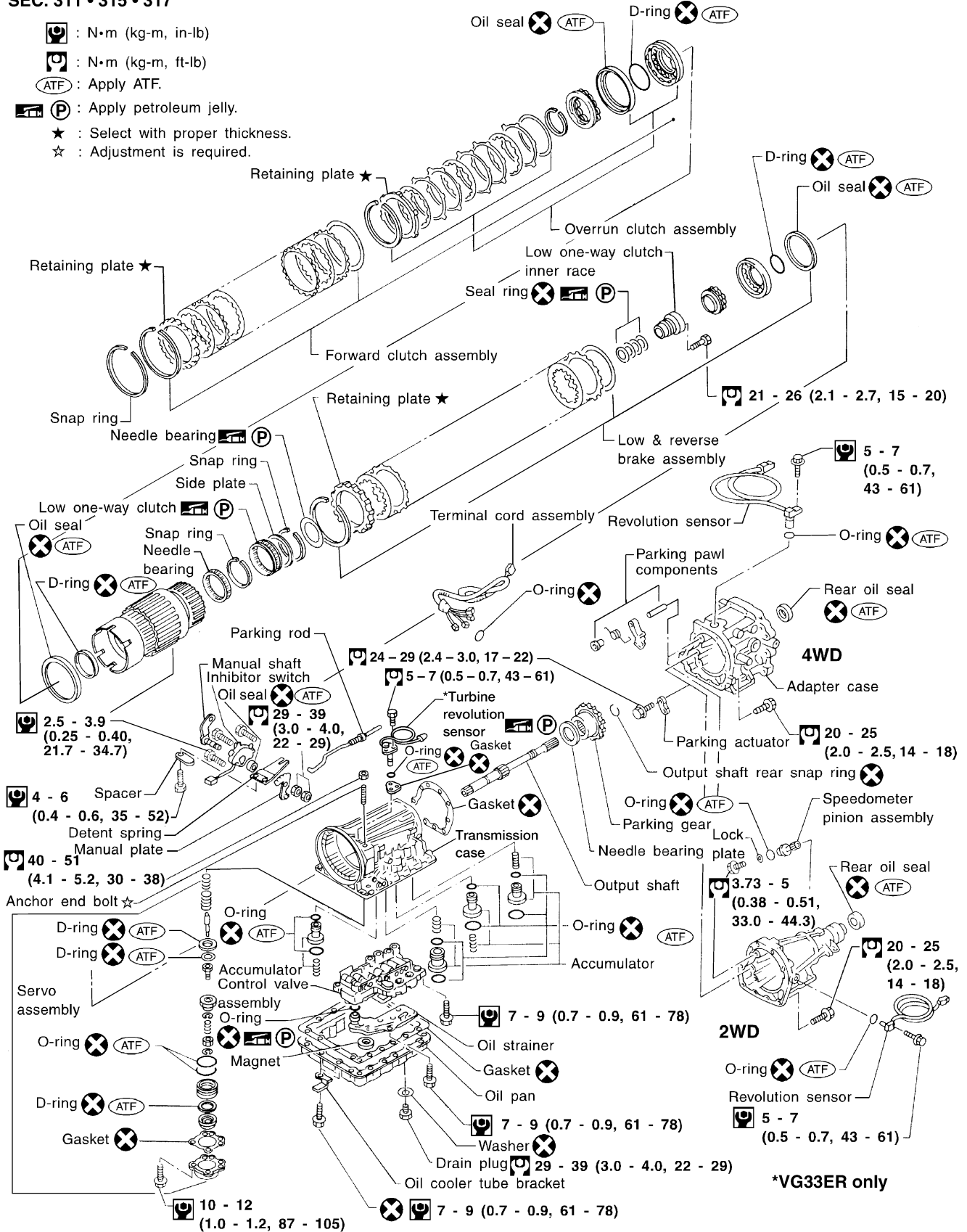

GI
MA
EM
LC
EC
FE
CL
MT
AT
TF
PD
AX
SU
BR
ST
RS
BT
HA
SC
EL
IDX

LAT438

OVERHAUL

Oil Channel

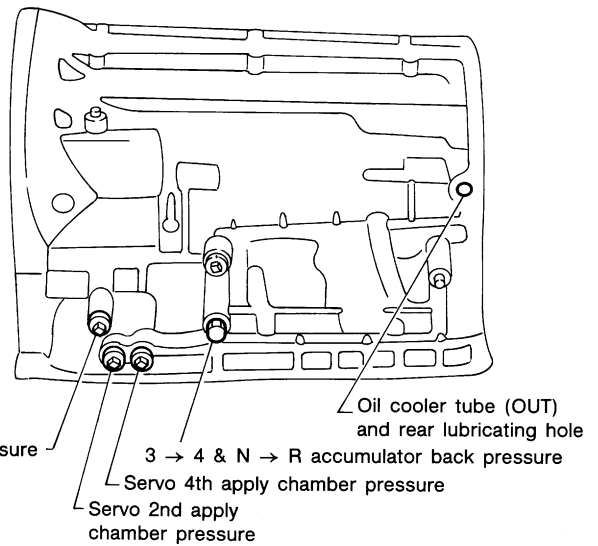
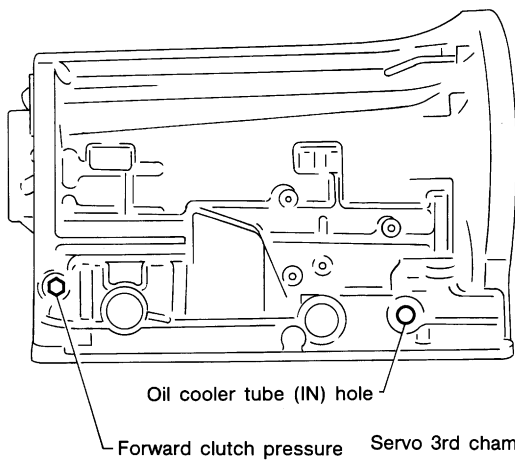
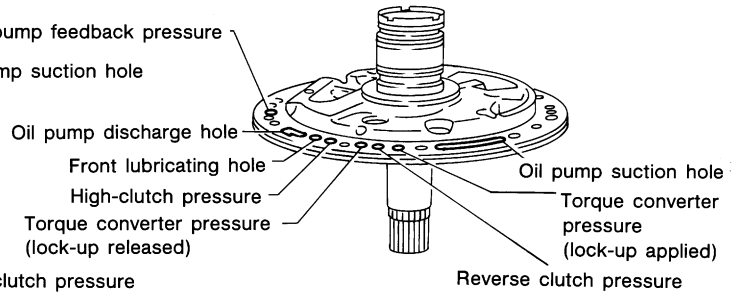
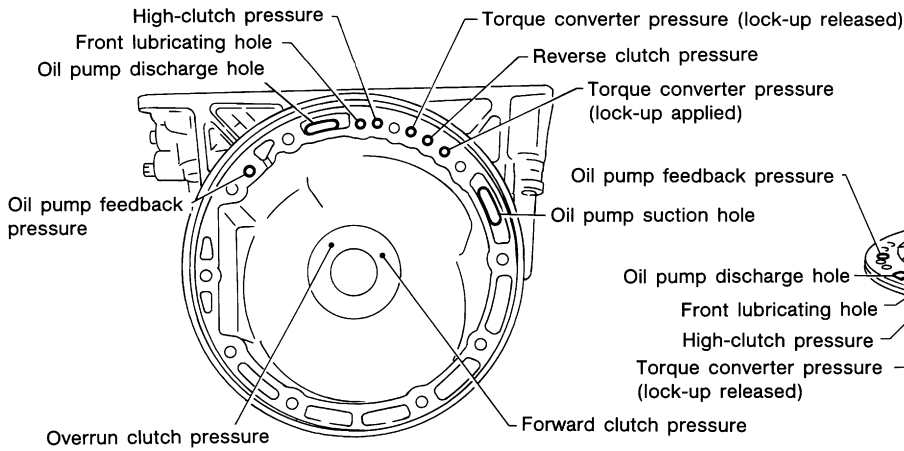
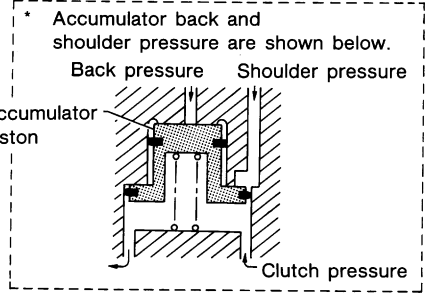
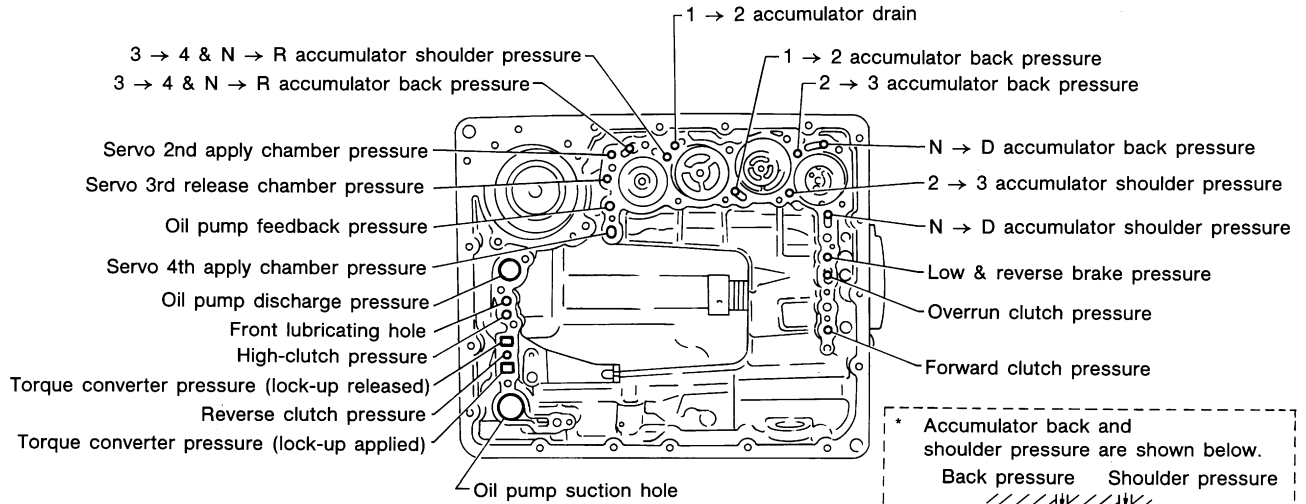

OVERHAUL

Locations of Needle Bearings, Thrust Washers and Snap Rings

Locations of Needle Bearings, Thrust Washers and Snap Rings

NGAT0110

Outer diameter of snap rings

Item number	Outer diameter mm (in)
②	161.0 (6.34)
③	140.1 (5.52)
④	156.4 (6.16)
⑥	142.0 (5.59)
⑦	159.2 (6.27)

Thrust washers

Item number	Color
①	Black
⑤	White

Outer diameter of needle bearings

Item number	Outer diameter mm (in)
⑧	47 (1.85)
⑨	53 (2.09)
⑪	78 (3.07)
⑫	53 (2.09)
⑬	78 (3.07)
⑭	57 (2.24)
⑮	78.1 (3.075)
⑯	64 (2.52)
⑰	53 (2.09)

Inner diameter of bearing races

Item number	Outer diameter mm (in)
⑪	58 (2.315)
⑬	58 (2.315)

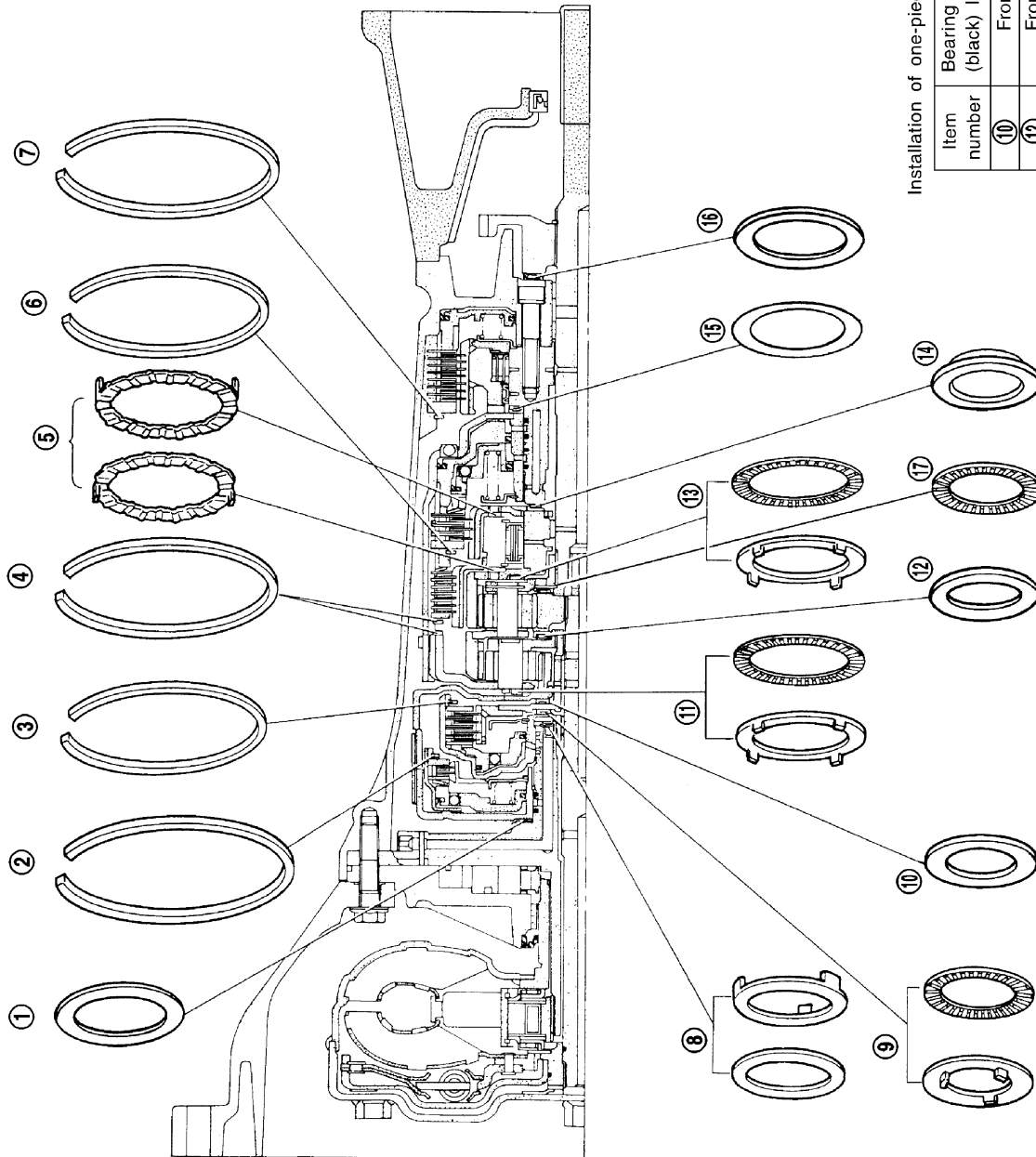

Installation of one-piece bearings

Item number	Bearing race (black) location
⑩	Front
⑫	Front
⑮	Rear side
⑯	Rear side

GI
MA
EM
LC
EC
FE
CL
MT
AT
TF
PD
AX
SU
BR
ST
RS
BT
HA
SC
EL
IDX

WAT378

DISASSEMBLY

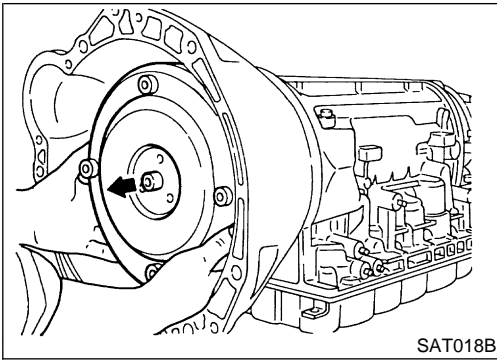

1. Drain ATF through drain plug.
2. Remove turbine revolution sensor (VG33ER only).
3. Remove torque converter by holding it firmly and turning while pulling straight out.

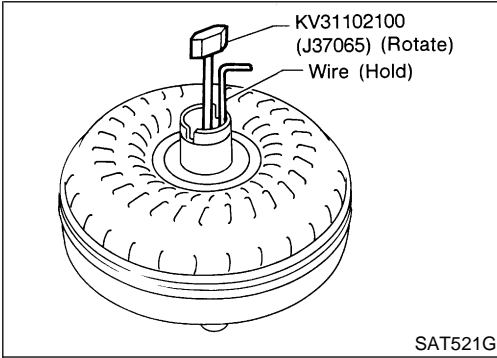

4. Check torque converter one-way clutch.
 - a. Insert Tool into spline of one-way clutch inner race.
 - b. Hook bearing support unitized with one-way clutch outer race with suitable wire.
 - c. Check that one-way clutch inner race rotates only clockwise with Tool while holding bearing support with wire.

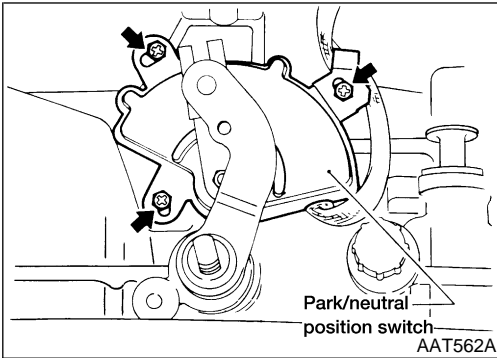

5. Remove park/neutral position (PNP) switch from transmission case.

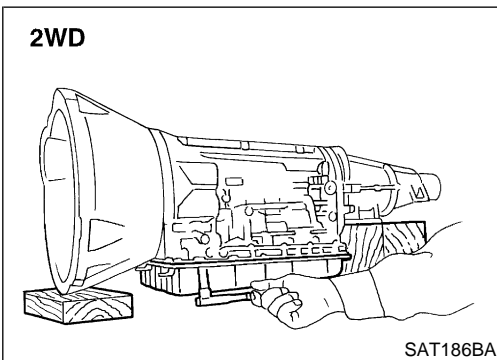

6. Remove oil pan.
 - Always place oil pan straight down so that foreign particles inside will not move.
 - Always replace oil pan bolts as they are self-sealing bolts.

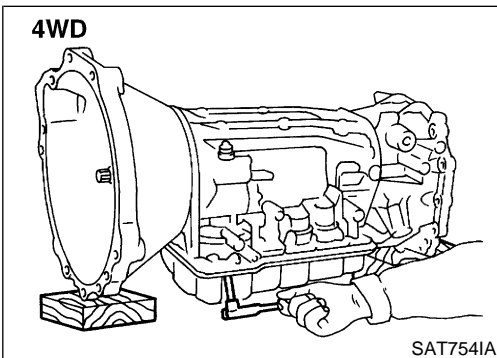

DISASSEMBLY

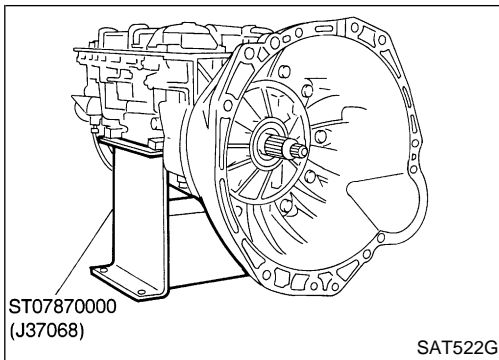

7. Place transmission into Tool with the control valve facing up.

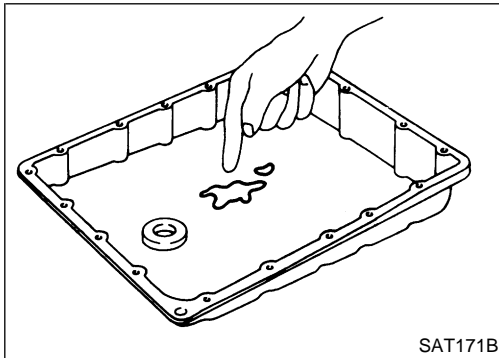

8. Check foreign materials in oil pan to help determine cause of malfunction. If the fluid is very dark, smells burned, or contains foreign particles, the frictional material (clutches, band) may need replacement. A tacky film that will not wipe clean indicates varnish build up. Varnish can cause valves, servo, and clutches to stick and may inhibit pump pressure.

- **If frictional material is detected, replace radiator after repair of A/T. Refer to LC-14, "Radiator".**

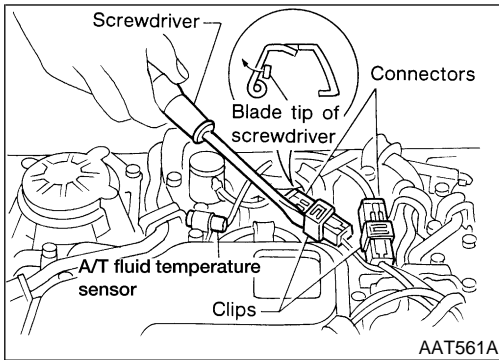

9. Remove torque converter clutch solenoid valve and A/T fluid temperature sensor connectors.

- **Be careful not to damage connector.**

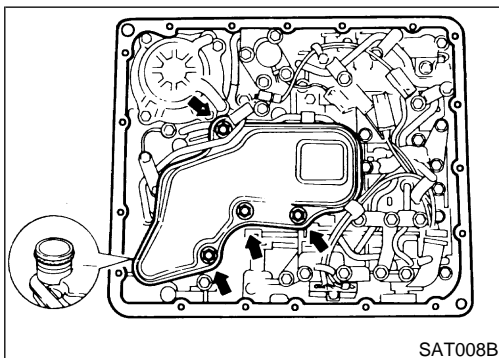

10. Remove oil strainer.

- Remove oil strainer from control valve assembly. Then remove O-ring from oil strainer.

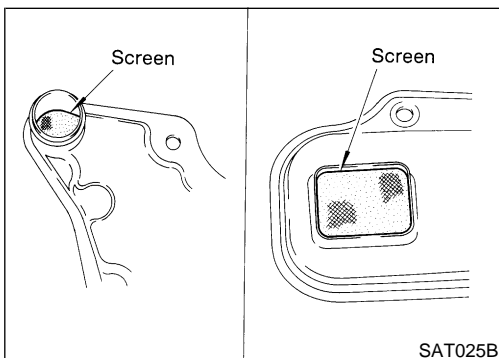

- Check oil strainer screen for damage.

GI

MA

EM

LC

EC

FE

CL

MT

AT

TF

PD

AX

SU

BR

ST

RS

BT

HA

SC

EL

IDX

DISASSEMBLY

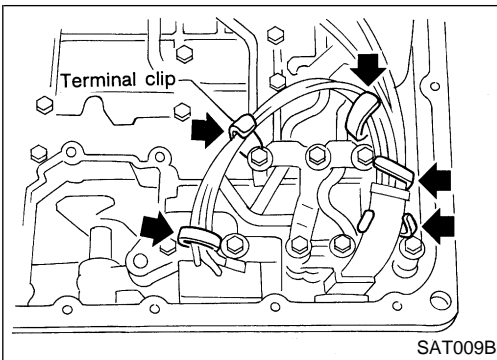

11. Remove control valve assembly.
- a. Straighten terminal clips to free terminal cords then remove terminal clips.

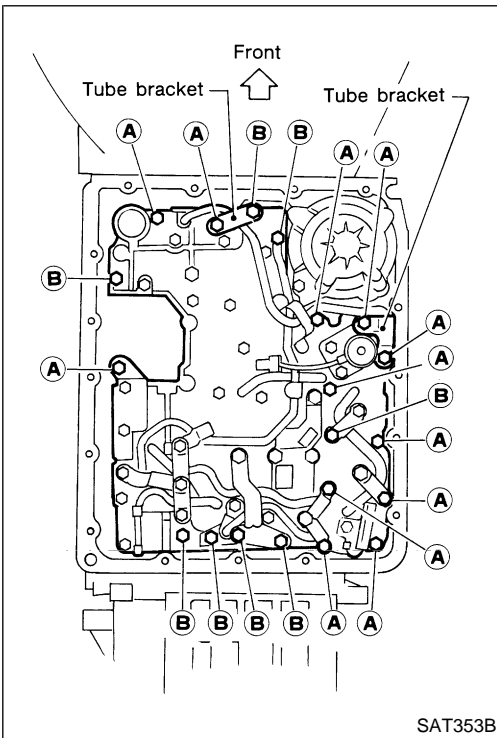

- b. Remove bolts A and B, and remove control valve assembly from transmission.

Bolt symbol	Length mm (in)
A	33 (1.30)
B	45 (1.77)

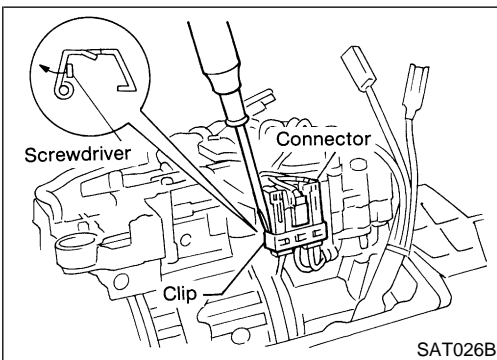

- c. Remove solenoid connector.
- **Be careful not to damage connector.**

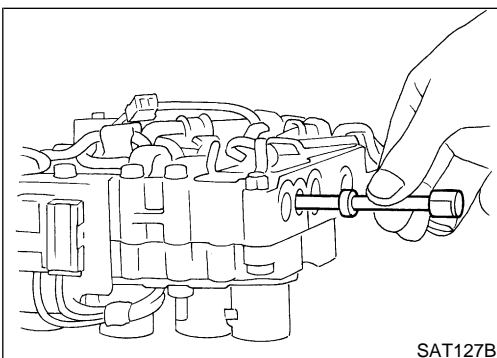

- d. Remove manual valve from control valve assembly.

DISASSEMBLY

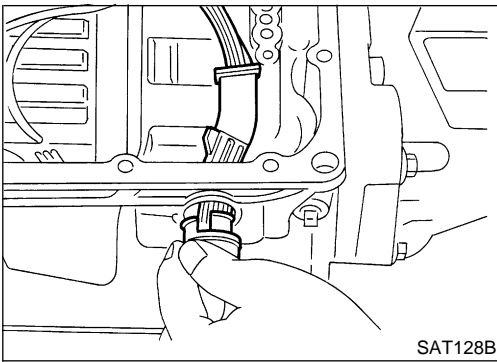

12. Remove terminal cord assembly from transmission case while pushing on stopper.

- Be careful not to damage cord.
- Do not remove terminal cord assembly unless it is damaged.

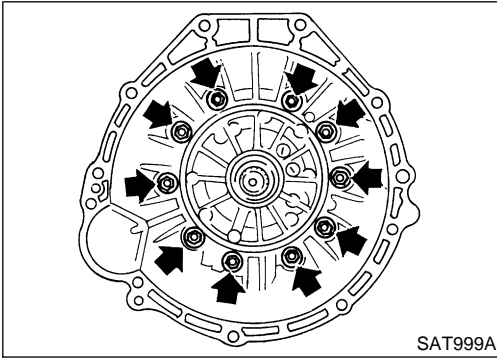

13. Remove converter housing from transmission case.

- Be careful not to scratch converter housing.

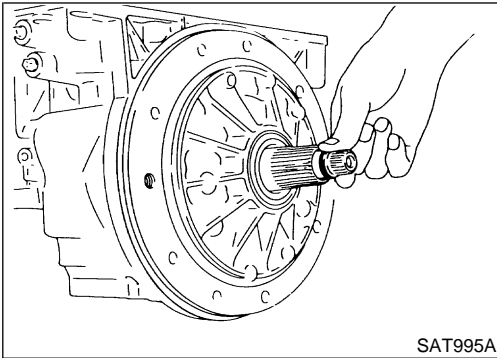

14. Remove O-ring from input shaft.

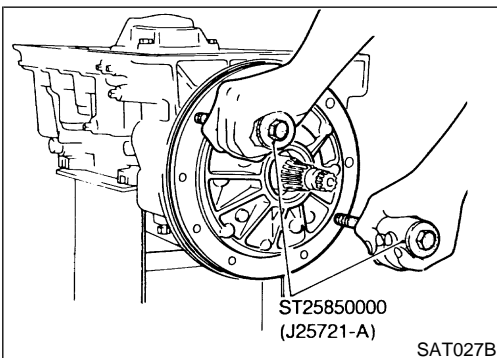

15. Remove oil pump assembly.

- a. Attach Tool to oil pump assembly and extract it evenly from transmission case.

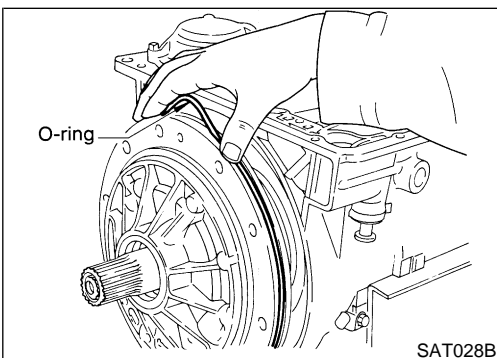

b. Remove O-ring from oil pump assembly.

c. Remove traces of sealant from oil pump housing.

- Be careful not to scratch pump housing.

GI

MA

EM

LC

EC

FE

CL

MT

AT

TF

PD

AX

SU

BR

ST

RS

BT

HA

SC

EL

IDX

DISASSEMBLY

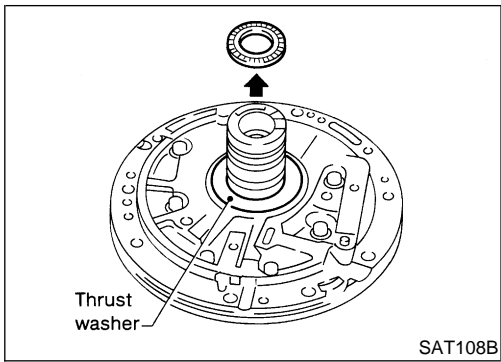

- d. Remove needle bearing and thrust washer from oil pump assembly.

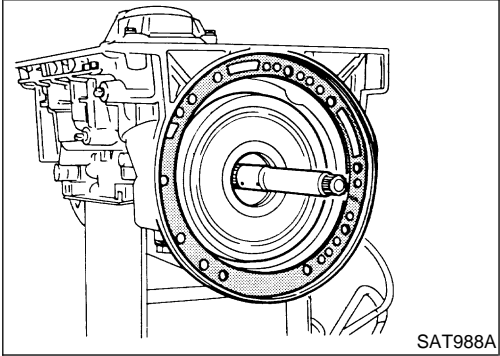

16. Remove input shaft and oil pump gasket.

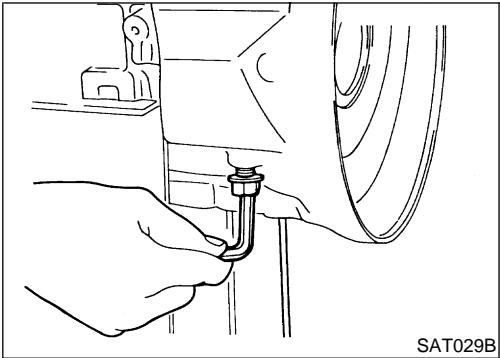

17. Remove brake band and band strut.

- a. Loosen lock nut and remove band servo anchor end pin from transmission case.

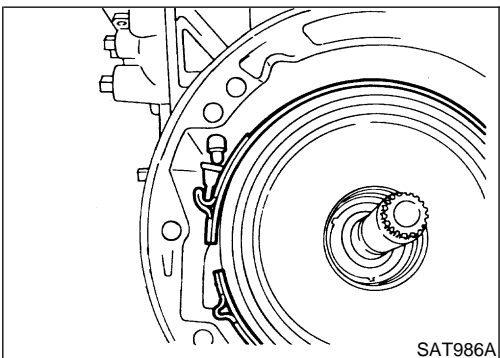

- b. Remove brake band and band strut from transmission case.

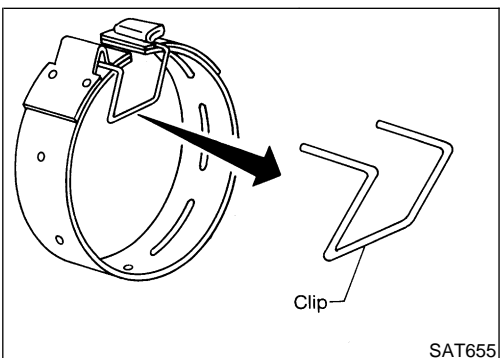

- c. Hold brake band in a circular shape with clip.

DISASSEMBLY

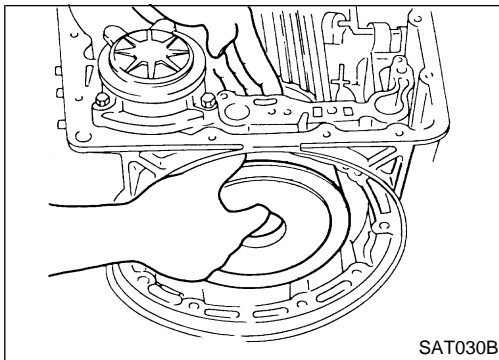

18. Remove front side clutch and gear components.
- Remove clutch pack (reverse clutch, high clutch and front sun gear) from transmission case.

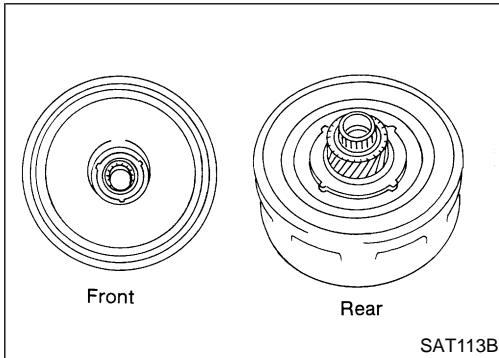

- Remove front bearing race from clutch pack.
- Remove rear bearing race from clutch pack.

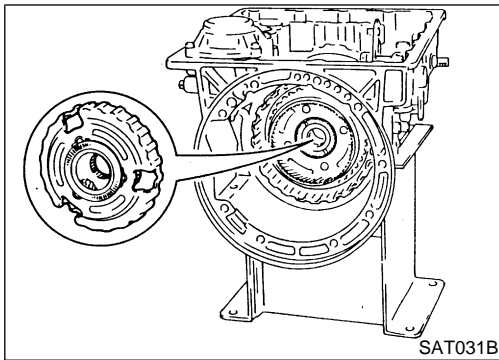

- Remove front planetary carrier from transmission case.

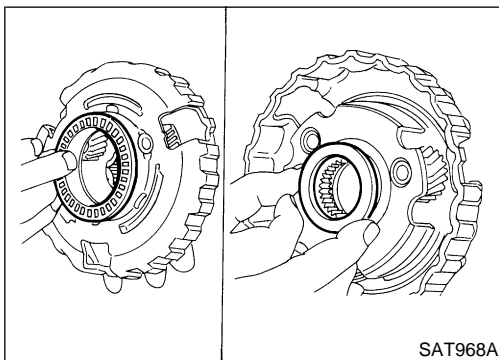

- Remove front needle bearing from front planetary carrier.
- Remove rear bearing from front planetary carrier.

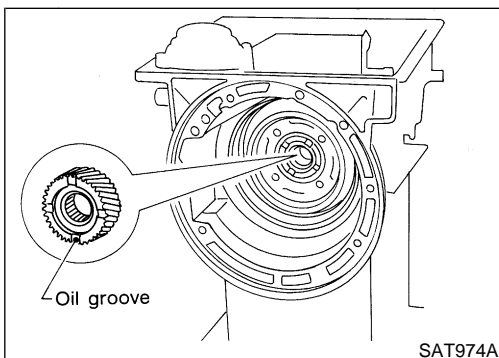

- Remove rear sun gear from transmission case.

GI

MA

EM

LC

EC

FE

CL

MT

AT

TF

PD

AX

SU

BR

ST

RS

BT

HA

SC

EL

IDX

DISASSEMBLY

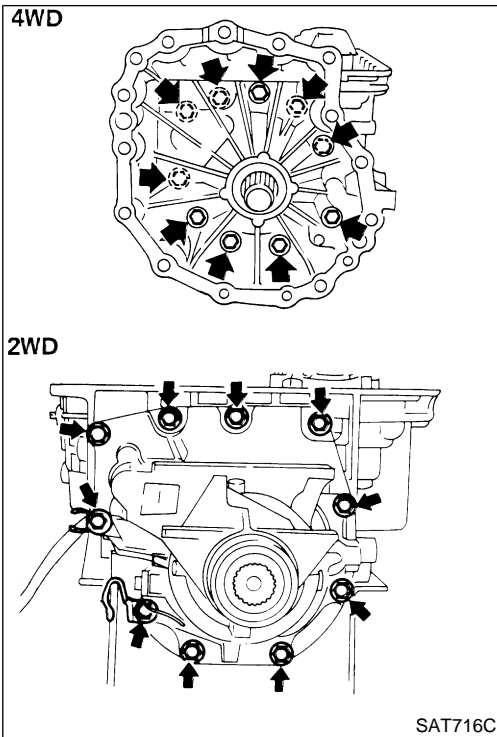

19. Remove rear extension or adapter case.
- Remove rear extension or adapter case from transmission case.
 - Remove rear extension or adapter case gasket from transmission case.

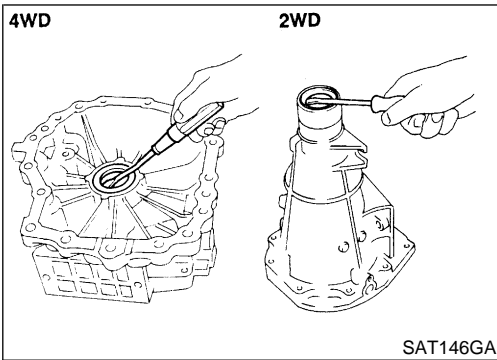

- Remove oil seal from adapter case or rear extension.
- Do not remove oil seal unless it is to be replaced.**

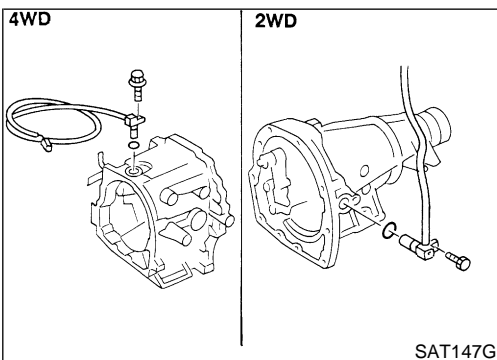

- Remove revolution sensor from adapter case or rear extension.
- Remove O-ring from revolution sensor.

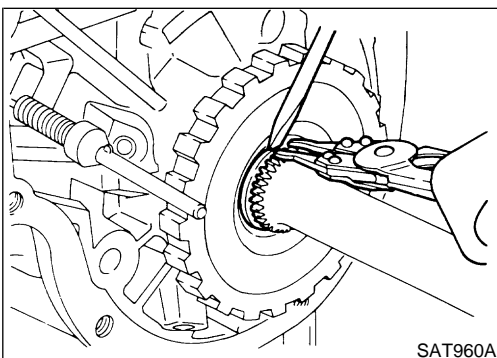

20. Remove output shaft and parking gear.
- Remove rear snap ring from output shaft.

DISASSEMBLY

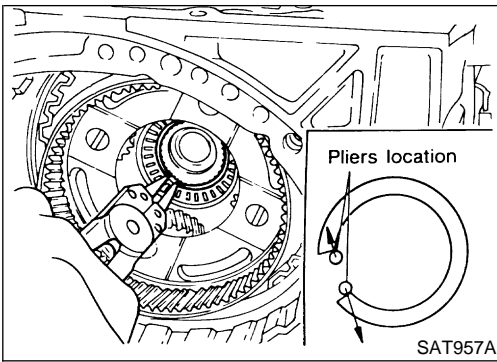

- b. Slowly push output shaft all the way forward.
 - **Do not use excessive force.**
- c. Remove snap ring from output shaft.

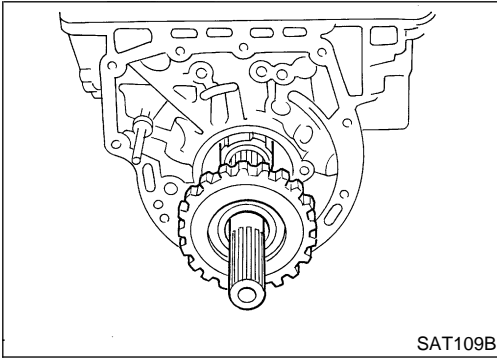

- d. Remove output shaft and parking gear as a unit from transmission case.
- e. Remove parking gear from output shaft.

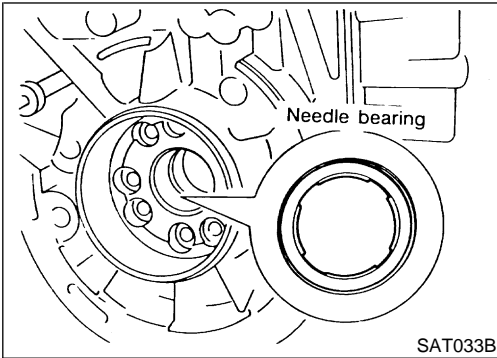

- f. Remove needle bearing from transmission case.

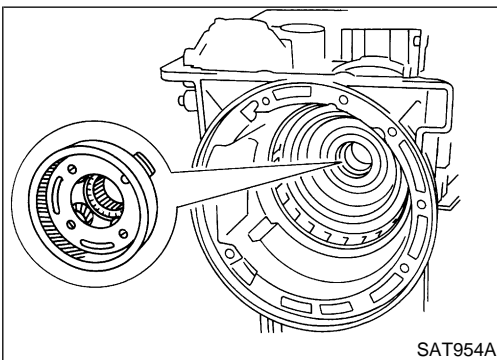

- 21. Remove rear side clutch and gear components.
 - a. Remove front internal gear.

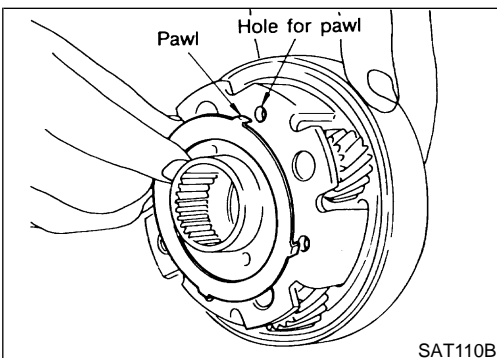

- b. Remove bearing race from front internal gear.

GI

MA

EM

LC

EC

FE

CL

MT

AT

TF

PD

AX

SU

BR

ST

RS

BT

HA

SC

EL

IDX

DISASSEMBLY

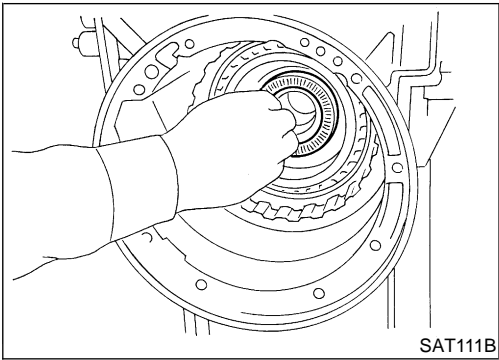

c. Remove needle bearing from rear internal gear.

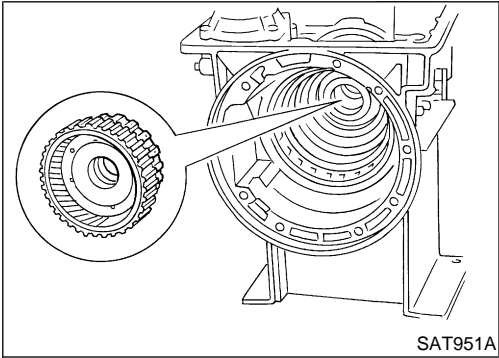

d. Remove rear internal gear, forward clutch hub and overrun clutch hub as a set from transmission case.

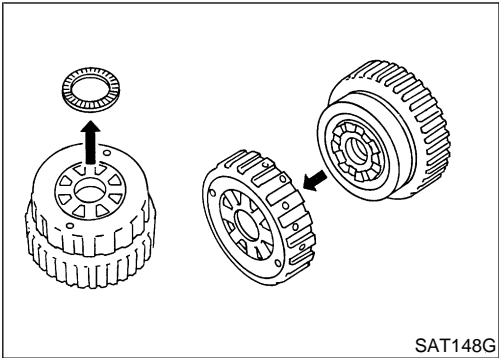

e. Remove needle bearing from overrun clutch hub.
f. Remove overrun clutch hub from rear internal gear and forward clutch hub.

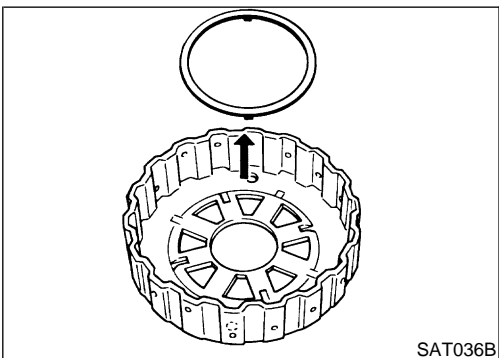

g. Remove thrust washer from overrun clutch hub.

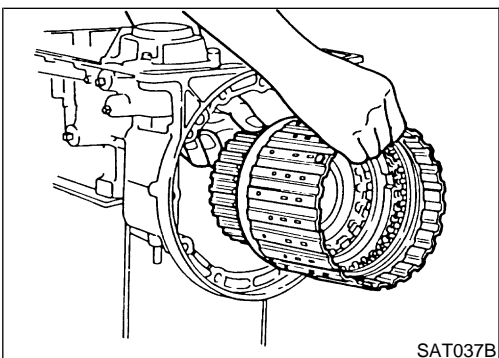

h. Remove forward clutch assembly from transmission case.

DISASSEMBLY

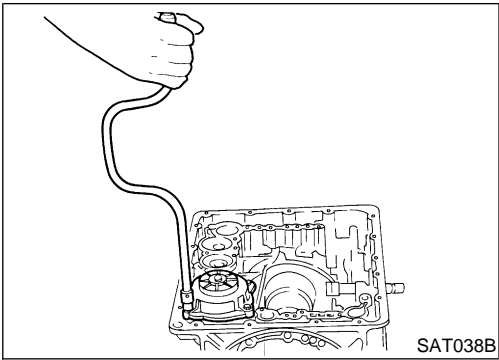

22. Remove band servo and accumulator components.
 a. Remove band servo retainer from transmission case.

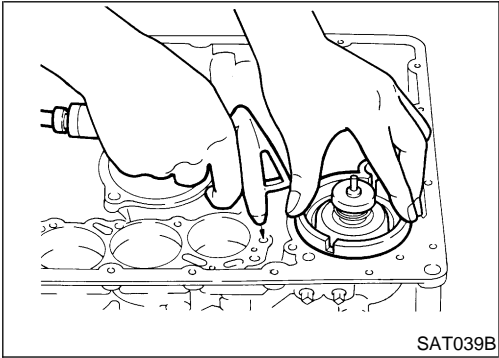

- b. Apply compressed air to oil hole until band servo piston comes out of transmission case.
 ● **Hold piston with a rag and gradually direct air to oil hole.**
 c. Remove return springs.

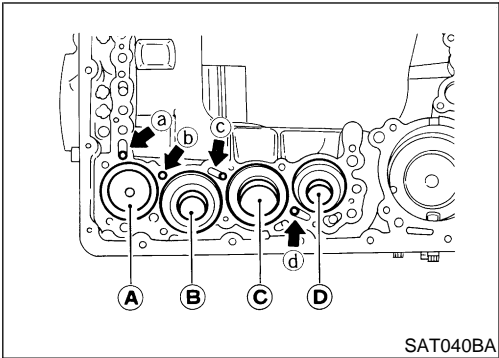

- d. Remove springs from accumulator pistons B, C and D.
 e. Apply compressed air to each oil hole until piston comes out.
 ● **Hold piston with a rag and gradually direct air to oil hole.**

Identification of accumulator pistons	A	B	C	D
Identification of oil holes	a	b	c	d

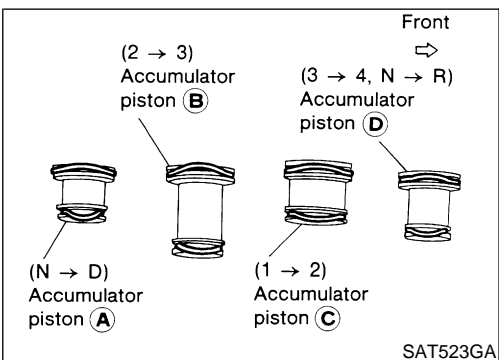

- f. Remove O-ring from each piston.

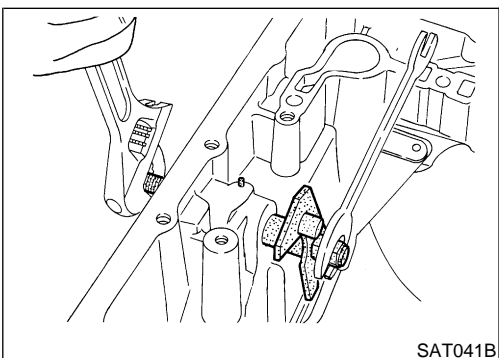

23. Remove manual shaft components, if necessary.
 a. Hold width across flats of manual shaft (outside the transmission case) and remove lock nut from shaft.

GI
 MA
 EM
 LC
 EC
 FE
 CL
 MT
 AT
 TF
 PD
 AX
 SU
 BR
 ST
 RS
 BT
 HA
 SC
 EL
 IDX

DISASSEMBLY

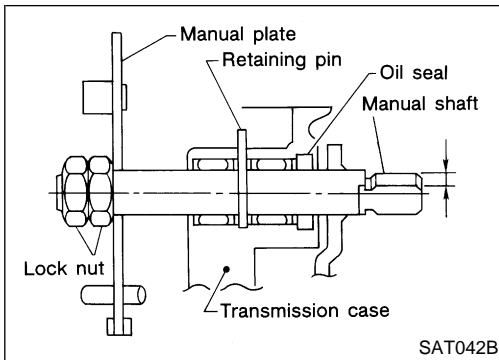

b. Remove retaining pin from transmission case.

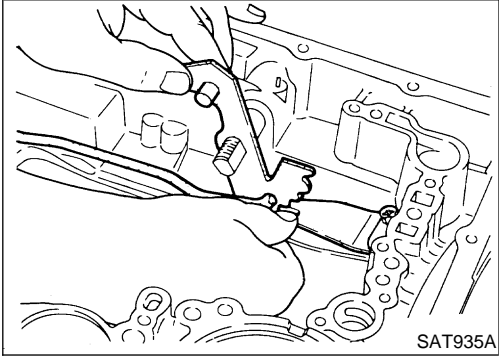

c. While pushing detent spring down, remove manual plate and parking rod from transmission case.

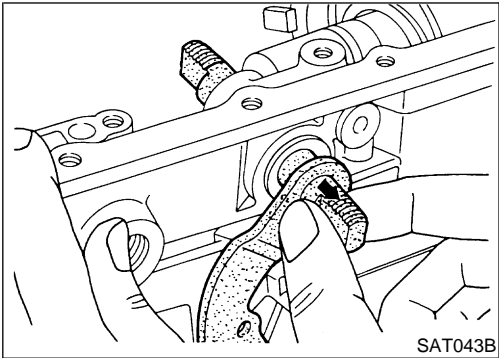

d. Remove manual shaft from transmission case.

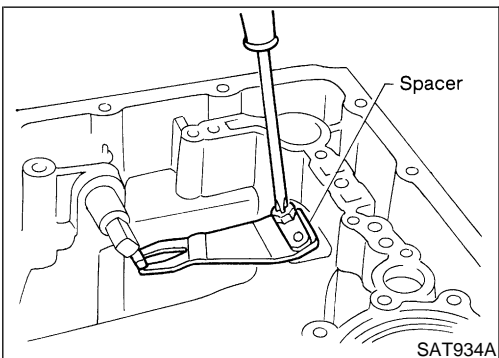

e. Remove spacer and detent spring from transmission case.

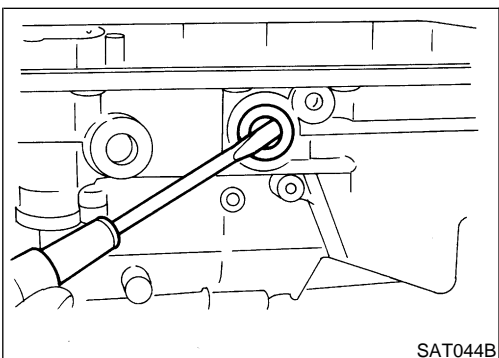

f. Remove oil seal from transmission case.

Oil Pump COMPONENTS

NGAT0112

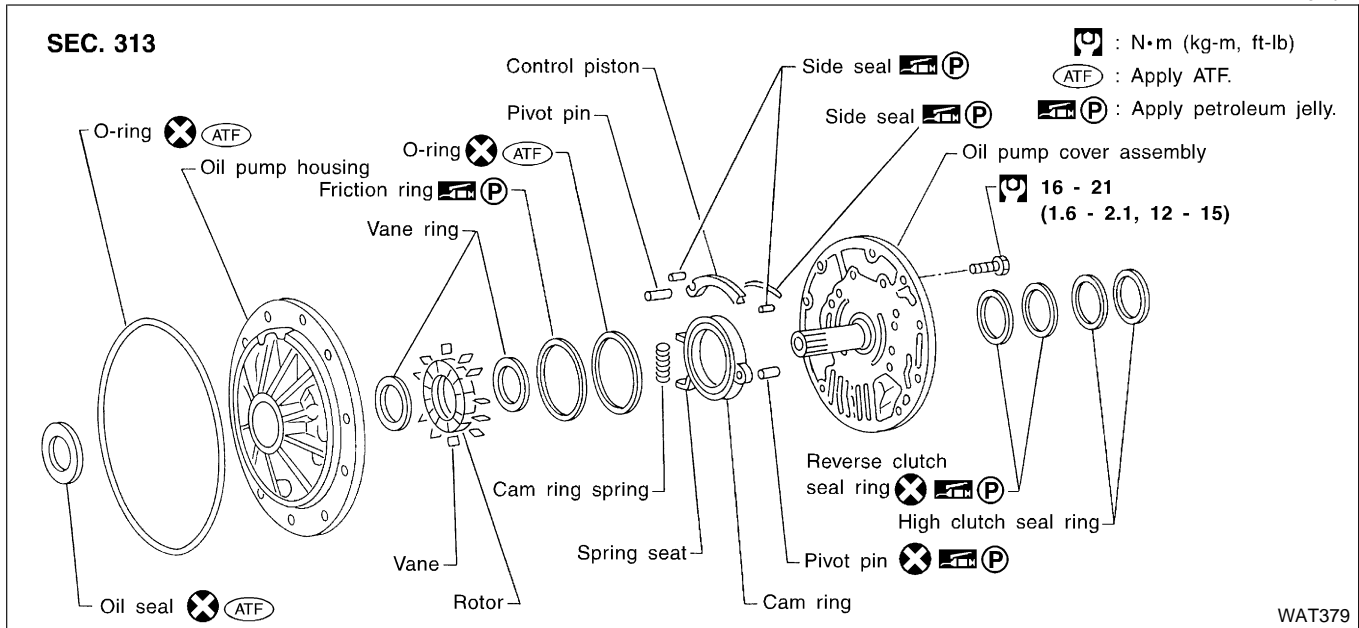

GI
MA
EM
LC
EC
FE
CL
MT

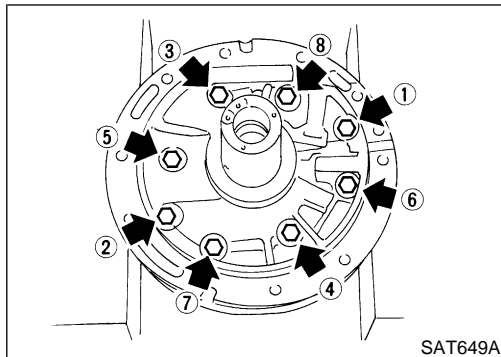

DISASSEMBLY

NGAT0113

- Loosen bolts in numerical order and remove oil pump cover.

AT

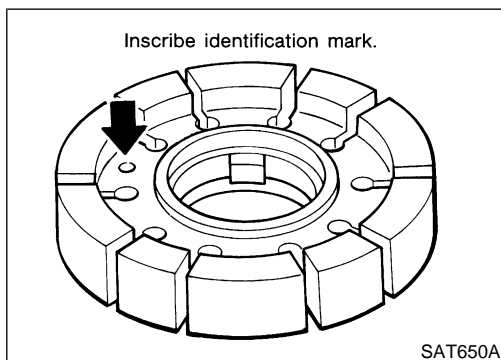

- Remove rotor, vane rings and vanes.
 - Inscribe a mark on back of rotor for identification of fore-aft direction when reassembling rotor. Then remove rotor.

TF

PD

AX

SU

BR

ST

RS

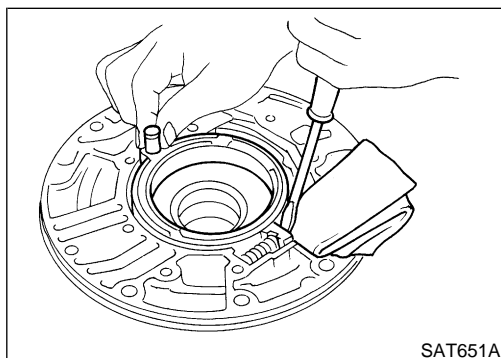

- While pushing on cam ring remove pivot pin.
 - Be careful not to scratch oil pump housing.

BT

HA

SC

EL

IDX

REPAIR FOR COMPONENT PARTS

Oil Pump (Cont'd)

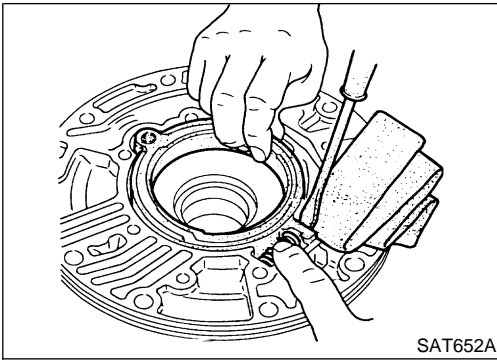

4. While holding cam ring and spring lift out cam ring spring.
 - Be careful not to damage oil pump housing.
 - Hold cam ring spring to prevent it from jumping.

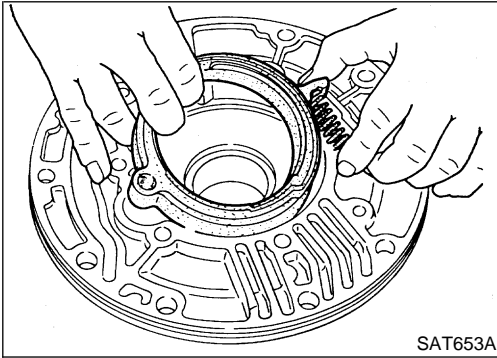

5. Remove cam ring and cam ring spring from oil pump housing.

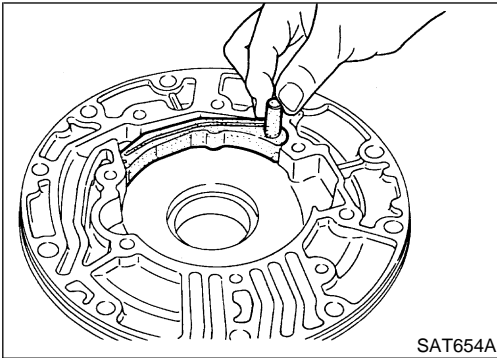

6. Remove pivot pin from control piston and remove control piston assembly.

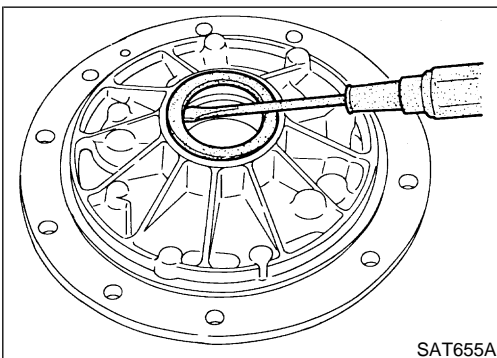

7. Remove oil seal from oil pump housing.
 - Be careful not to scratch oil pump housing.

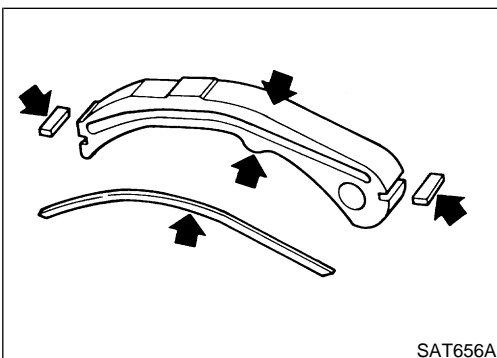

INSPECTION

Oil Pump Cover, Rotor, Vanes, Control Piston, Side Seals, Cam Ring and Friction Ring

NGAT0114

- Check for wear or damage.

NGAT0114S01

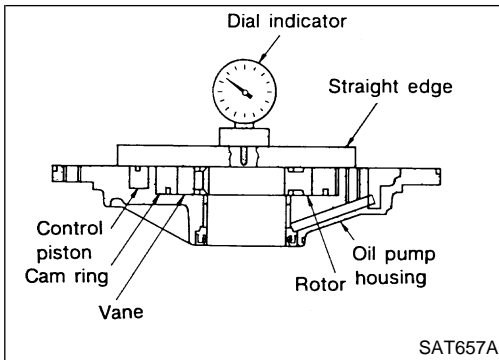

Side Clearances

NGAT0114S02

- Measure side clearances between end of oil pump housing and cam ring, rotor, vanes and control piston. Measure in at least four places along their circumferences. Maximum measured values should be within specified positions.
- **Before measurement, check that friction rings, O-ring, control piston side seals and cam ring spring are removed.**

Standard clearance (Cam ring, rotor, vanes and control piston):

Refer to "SERVICE DATA AND SPECIFICATIONS (SDS)", AT-353.

- If not within standard clearance, replace oil pump assembly except oil pump cover assembly.

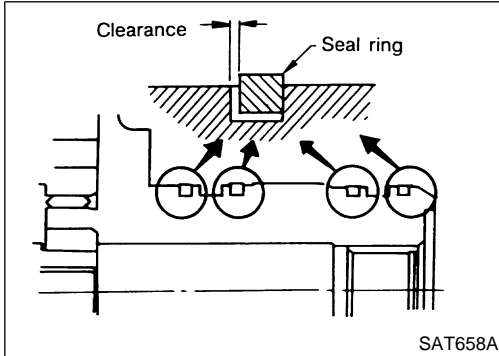

Seal Ring Clearance

NGAT0114S03

- Measure clearance between seal ring and ring groove.

Standard clearance:

0.10 - 0.25 mm (0.0039 - 0.0098 in)

Wear limit:

0.25 mm (0.0098 in)

- If not within wear limit, replace oil pump cover assembly.

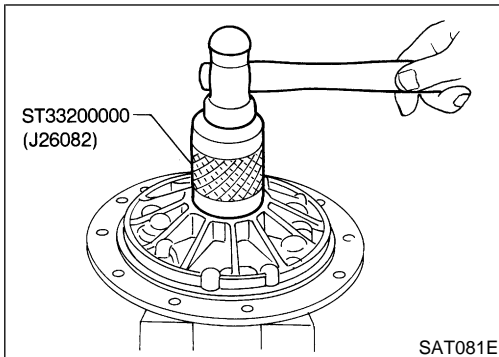

ASSEMBLY

NGAT0115

1. Drive oil seal into oil pump housing.
 - **Apply ATF to outer periphery and lip surface.**

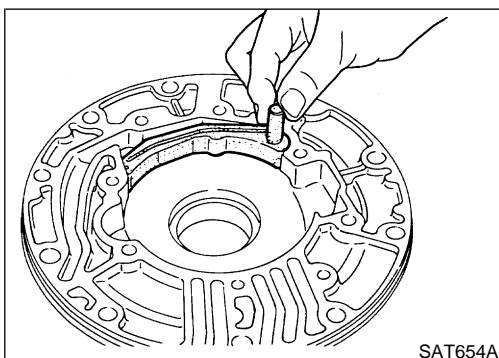

2. Install cam ring in oil pump housing by the following
 - a. Install side seal on control piston.
 - **Pay attention to its direction — Black surface goes toward control piston.**
 - **Apply petroleum jelly to side seal.**
 - b. Install control piston on oil pump.

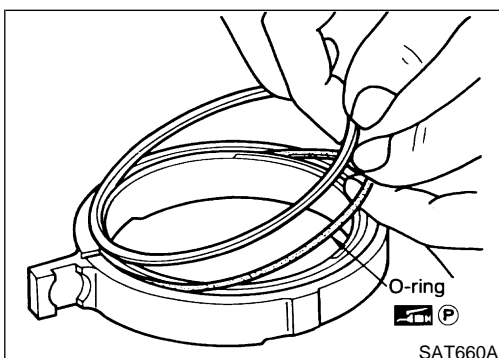

- c. Install O-ring and friction ring on cam ring.
 - **Apply petroleum jelly to O-ring.**

GI
MA
EM
LC
EC
FE
CL
MT
AT
TF
PD
AX
SU
BR
ST
RS
BT
HA
SC
EL
IDX

REPAIR FOR COMPONENT PARTS

Oil Pump (Cont'd)

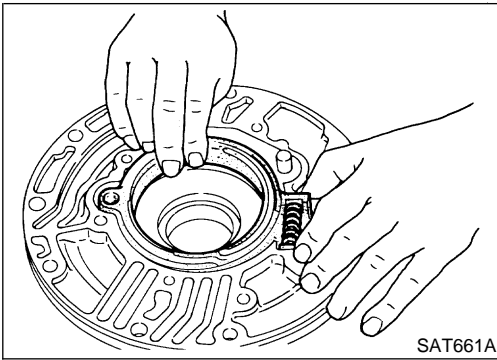

- d. Assemble cam ring, cam ring spring and spring seat. Install spring by pushing it against pump housing.

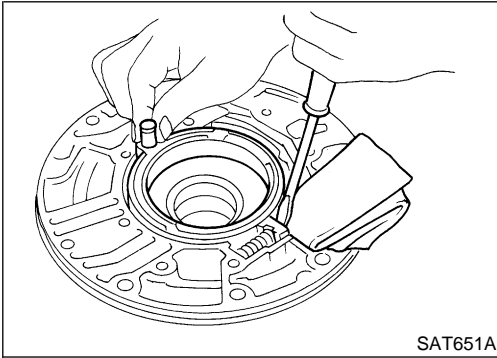

- e. While pushing on cam ring install pivot pin.

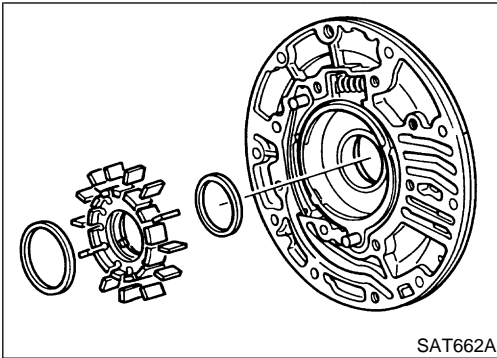

3. Install rotor, vanes and vane rings.
 - Pay attention to direction of rotor.

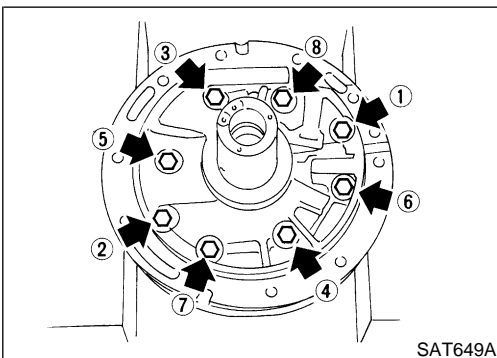

4. Install oil pump housing and oil pump cover.
 - a. Wrap masking tape around splines of oil pump cover assembly to protect seal. Position oil pump cover assembly in oil pump housing assembly, then remove masking tape.
 - b. Tighten bolts in a criss-cross pattern.

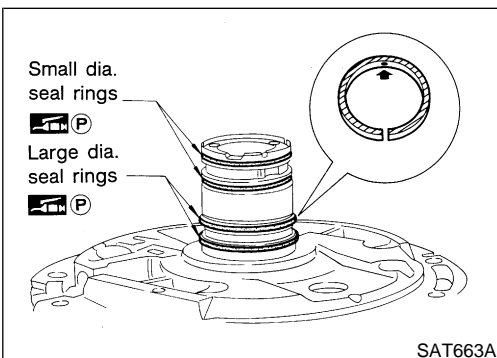

5. Install new seal rings carefully after packing ring grooves with petroleum jelly. Press rings down into jelly to a close fit.
 - Seal rings come in two different diameters. Check fit carefully in each groove.
 - Small dia. seal ring:
No mark
 - Large dia. seal ring:
Yellow mark in area shown by arrow
 - Do not spread gap of seal ring excessively while installing. It may deform ring.

Control Valve Assembly COMPONENTS

NGAT0116

SEC. 317

10 - 13
(1.0 - 1.3, 87 - 113)

Torque converter clutch solenoid valve

O-ring

Harness clip

7 - 9
(0.7 - 0.9, 61 - 78)

Harness clip

Lower body

Orifice check spring

Orifice check valve

Reamer bolt

Reamer bolt

Pilot filter

Separator plate

Side plate

Support plates

Steel ball

Upper body

O-ring

O-ring

Line pressure solenoid valve

3-unit solenoid assembly
(overrun clutch solenoid valve and
shift solenoid valves A and B)

7 - 9 (0.7 - 0.9, 61 - 78)

: N·m (kg-m, in-lb)

GI

MA

EM

LC

EC

FE

CL

MT

AT

TF

PD

AX

SU

BR

ST

RS

BT

HA

SC

EL

IDX

REPAIR FOR COMPONENT PARTS

Control Valve Assembly (Cont'd)

NGAT0117

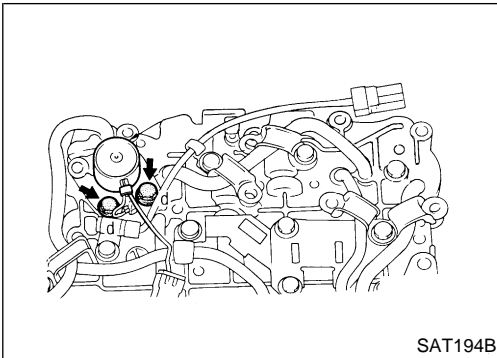

DISASSEMBLY

1. Remove solenoids.
 - a. Remove torque converter clutch solenoid valve and side plate from lower body.
 - b. Remove O-ring from solenoid.

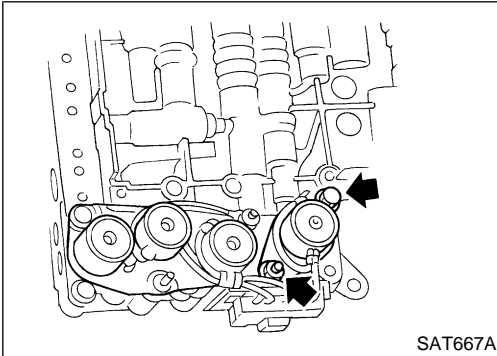

- c. Remove line pressure solenoid valve from upper body.
 - d. Remove O-ring from solenoid.

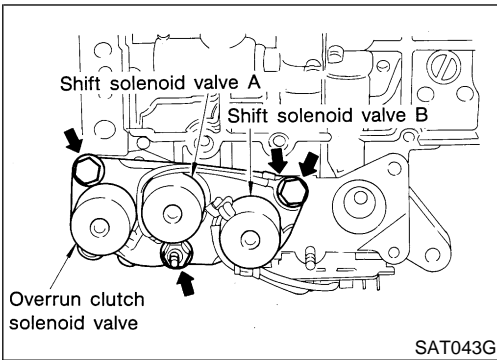

- e. Remove 3-unit solenoid assembly from upper body.
 - f. Remove O-rings from solenoids.

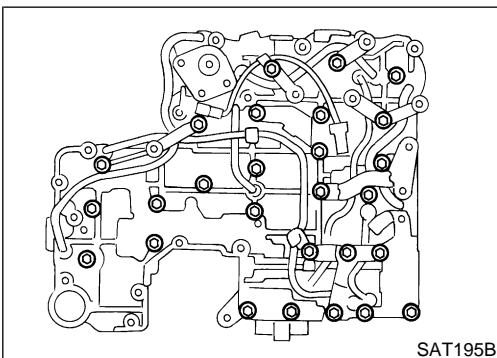

2. Disassemble upper and lower bodies.
 - a. Place upper body facedown, and remove bolts, reamer bolts, side plate and support plates.
 - b. Remove lower body and separator plate as a unit from upper body.
 - **Be careful not to drop pilot filter, orifice check valve, spring and steel balls.**

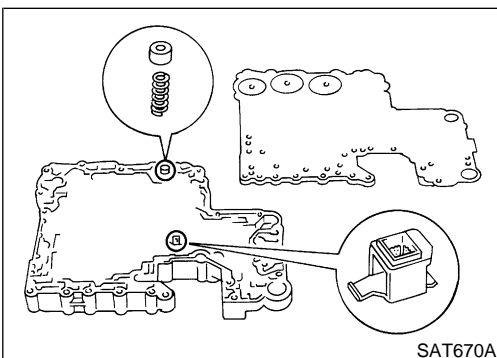

- c. Place lower body facedown, and remove separator plate.
 - d. Remove pilot filter, orifice check valve and orifice check spring.

REPAIR FOR COMPONENT PARTS

Control Valve Assembly (Cont'd)

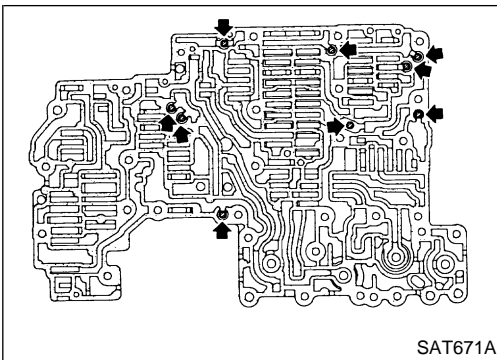

- e. Check to see that steel balls are properly positioned in upper body. Then remove them from upper body.

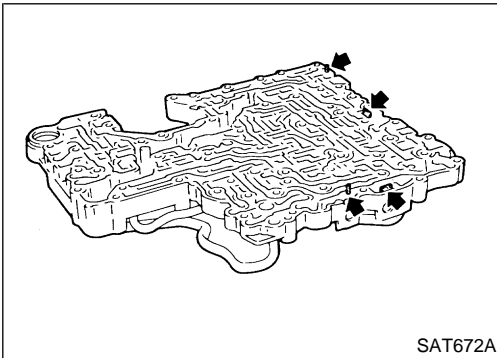

INSPECTION Lower and Upper Bodies

NGAT0118

NGAT0118S01

- Check to see that there are pins and retainer plates in lower body.

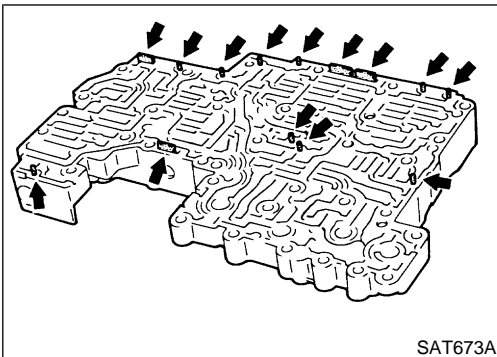

- Check to see that there are pins and retainer plates in upper body.
- **Be careful not to lose these parts.**

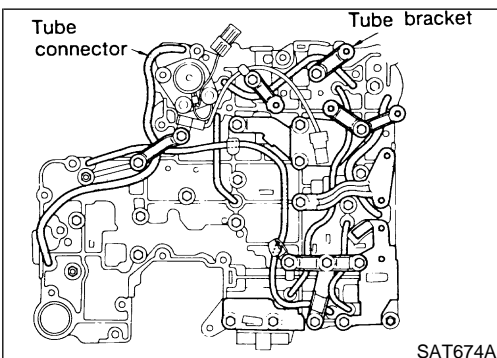

- Check to make sure that oil circuits are clean and free from damage.
- Check tube brackets and tube connectors for damage.

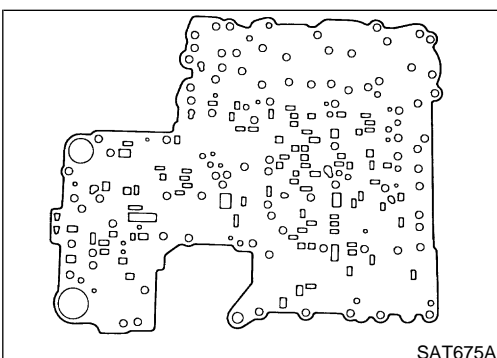

Separator Plate

NGAT0118S02

- Make sure that separator plate is free of damage and not deformed and oil holes are clean.

GI

MA

EM

LC

EC

FE

CL

MT

AT

TF

PD

AX

SU

BR

ST

RS

BT

HA

SC

EL

IDX

REPAIR FOR COMPONENT PARTS

Control Valve Assembly (Cont'd)

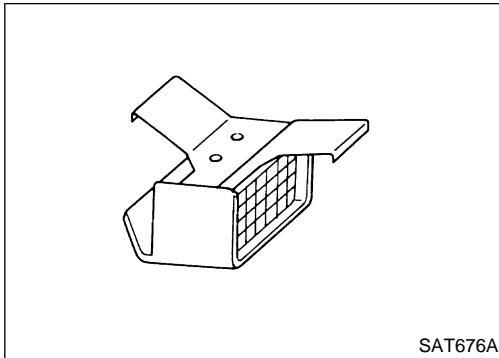

Pilot Filter

NGAT0118S03

- Check to make sure that filter is not clogged or damaged.

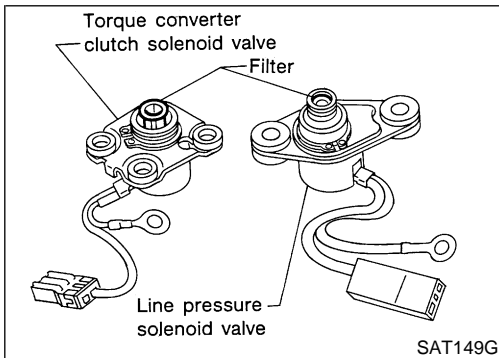

Torque Converter Clutch Solenoid Valve

NGAT0118S04

- Check that filter is not clogged or damaged.
- Measure resistance. Refer to "Component Inspection", AT-152.

Line Pressure Solenoid Valve

NGAT0118S05

- Check that filter is not clogged or damaged.
- Measure resistance. Refer to "Component Inspection", AT-164.

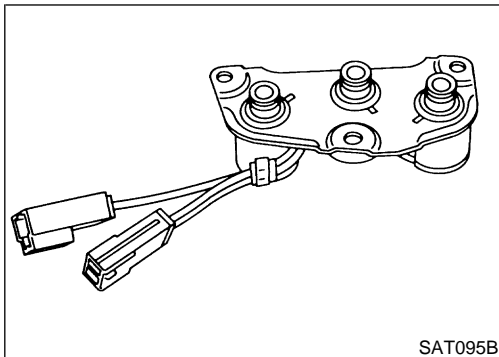

3-Unit Solenoid Assembly (Overrun Clutch Solenoid Valve and Shift Solenoid Valves A and B)

NGAT0118S06

- Measure resistance of each solenoid. Refer to "Component Inspection", AT-173, 178, 192.

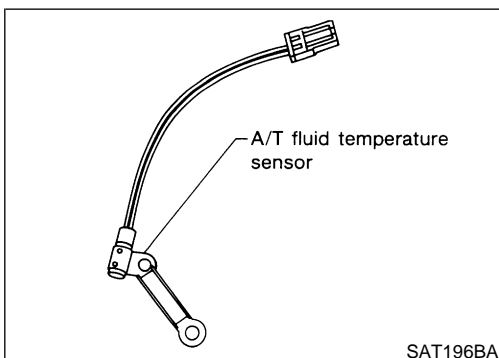

A/T Fluid Temperature Sensor

NGAT0118S07

- Measure resistance. Refer to "Component Inspection", AT-115.

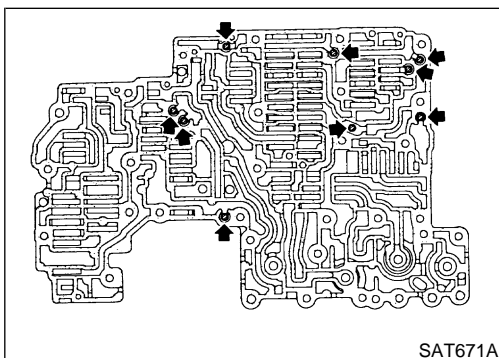

ASSEMBLY

NGAT0119

1. Install upper and lower bodies.
 - a. Place oil circuit of upper body face up. Install steel balls in their proper positions.

REPAIR FOR COMPONENT PARTS

Control Valve Assembly (Cont'd)

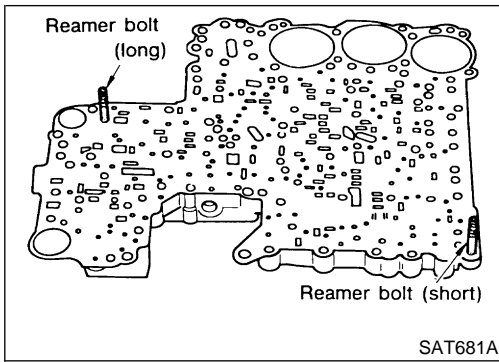

b. Install reamer bolts from bottom of upper body.

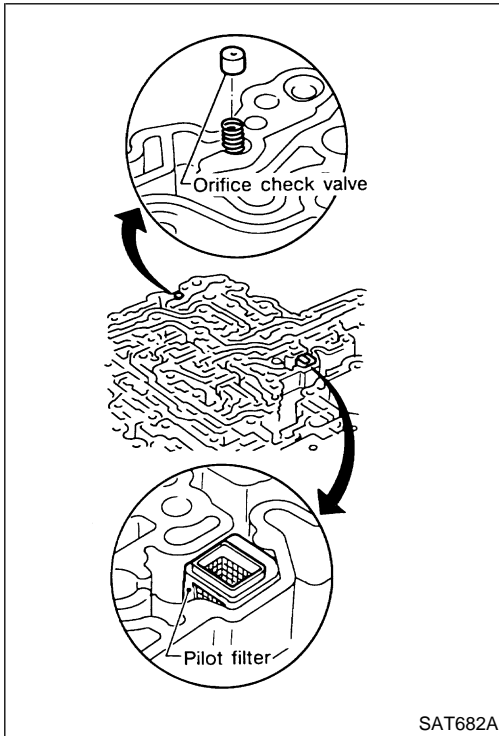

c. Place oil circuit of lower body face up. Install orifice check spring, orifice check valve and pilot filter.

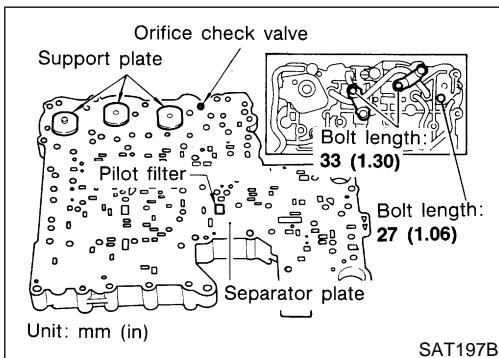

d. Install separator plate on lower body.

e. Install and temporarily tighten support plates, fluid temperature sensor and tube brackets.

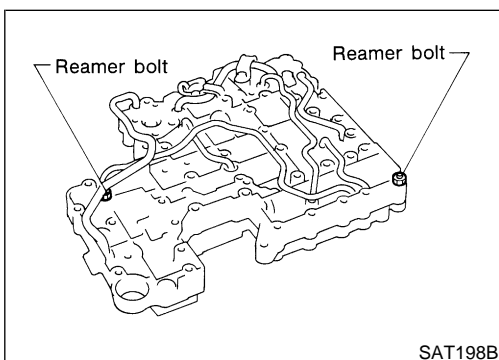

f. Temporarily assemble lower and upper bodies, using reamer bolt as a guide.

● **Be careful not to dislocate or drop steel balls, orifice check spring, orifice check valve and pilot filter.**

GI

MA

EM

LC

EC

FE

CL

MT

AT

TF

PD

AX

SU

BR

ST

RS

BT

HA

SC

EL

IDX

REPAIR FOR COMPONENT PARTS

Control Valve Assembly (Cont'd)

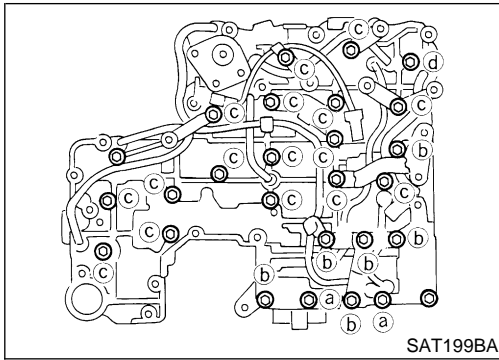

- g. Install and temporarily tighten bolts and tube brackets in their proper locations.

Bolt length and location:

Bolt symbol	a	b	c	d
Bolt length mm (in)	70 (2.76)	50 (1.97)	33 (1.30)	27 (1.06)

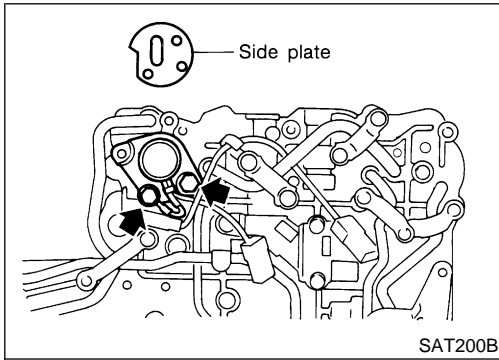

2. Install solenoids.
 a. Attach O-ring and install torque converter clutch solenoid valve and side plates onto lower body.

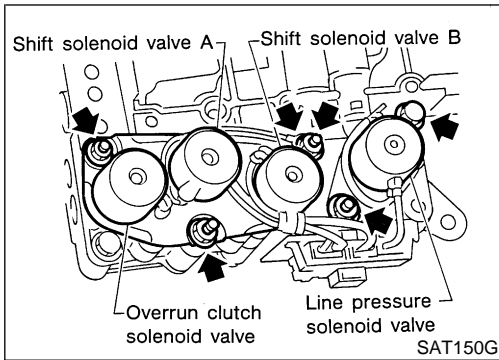

- b. Attach O-rings and install 3-unit solenoids assembly onto upper body.
 c. Attach O-ring and install line pressure solenoid valve onto upper body.
 3. Tighten all bolts.

REPAIR FOR COMPONENT PARTS

Control Valve Upper Body (Cont'd)

NGAT0121

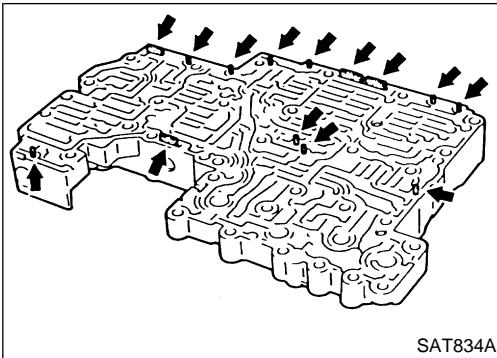

DISASSEMBLY

1. Remove valves at parallel pins.
 - Do not use a magnetic hand.

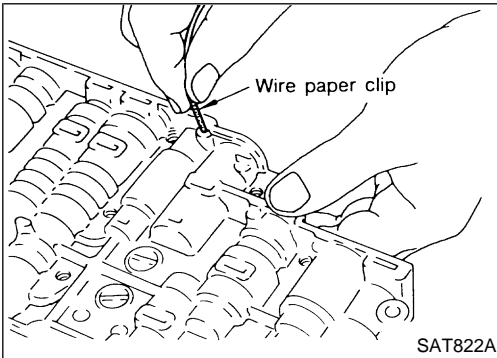

- a. Use a wire paper clip to push out parallel pins.

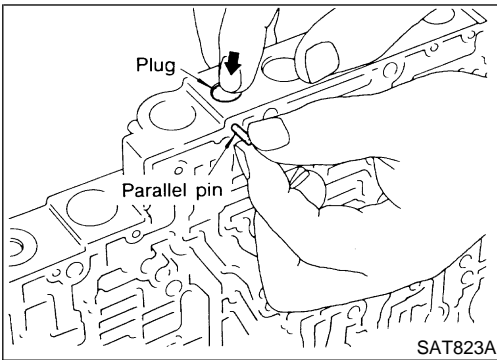

- b. Remove parallel pins while pressing their corresponding plugs and sleeves.
 - Remove plug slowly to prevent internal parts from jumping out.

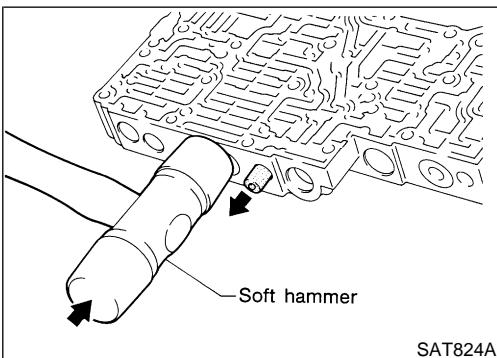

- c. Place mating surface of valve facedown, and remove internal parts.
 - If a valve is hard to remove, place valve body facedown and lightly tap it with a soft hammer.
 - Be careful not to drop or damage valves and sleeves.

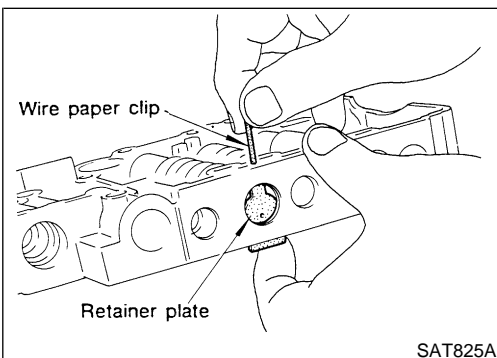

2. Remove valves at retainer plates.
 - a. Pry out retainer plate with wire paper clip.

REPAIR FOR COMPONENT PARTS

Control Valve Upper Body (Cont'd)

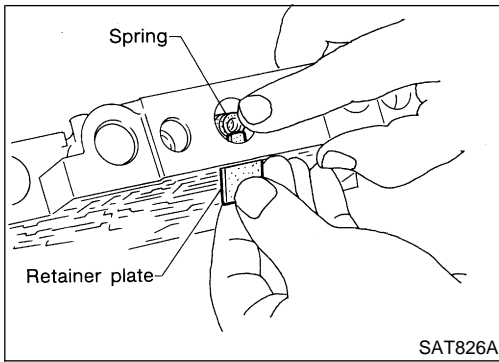

b. Remove retainer plates while holding spring.

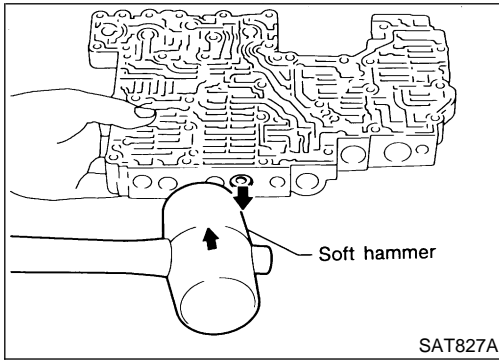

c. Place mating surface of valve facedown, and remove internal parts.

- If a valve is hard to remove, lightly tap valve body with a soft hammer.
- Be careful not to drop or damage valves, sleeves, etc.

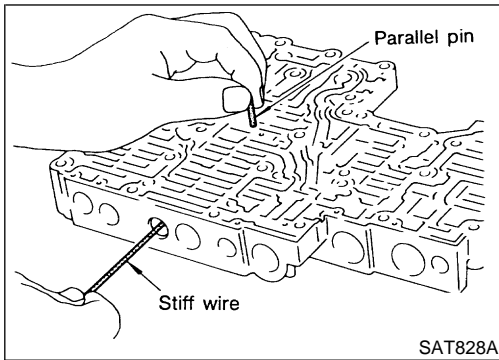

● 4-2 sequence valve and relay valve are located far back in upper body. If they are hard to remove, carefully push them out using stiff wire.

- Be careful not to scratch sliding surface of valve with wire.

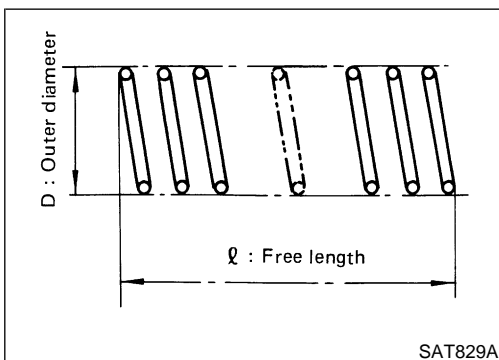

INSPECTION

Valve Springs

- Measure free length and outer diameter of each valve spring. Also check for damage or deformation.

Inspection standard:

Refer to "Return Springs", AT-349.

- Replace valve springs if deformed or fatigued.

Control Valves

- Check sliding surfaces of valves, sleeves and plugs.

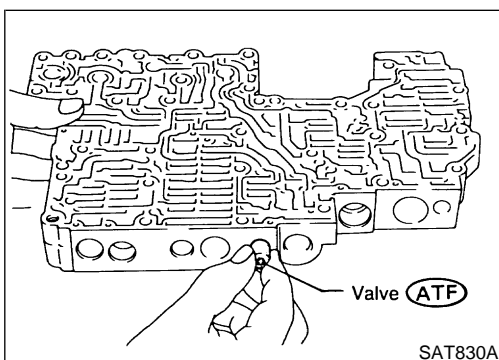

ASSEMBLY

1. Lubricate the control valve body and all valves with ATF. Install control valves by sliding them carefully into their bores.

- Be careful not to scratch or damage valve body.

GI

MA

EM

LC

EC

FE

CL

MT

AT

TF

PD

AX

SU

BR

ST

RS

BT

HA

SC

EL

IDX

REPAIR FOR COMPONENT PARTS

Control Valve Upper Body (Cont'd)

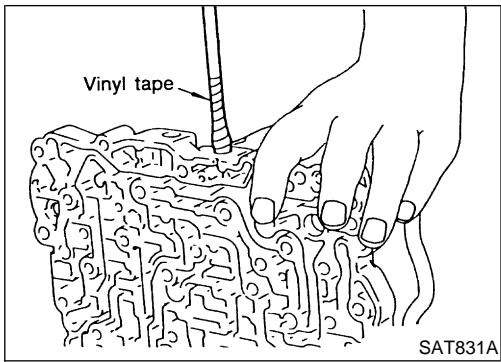

- Wrap a small screwdriver with vinyl tape and use it to insert the valves into proper position.

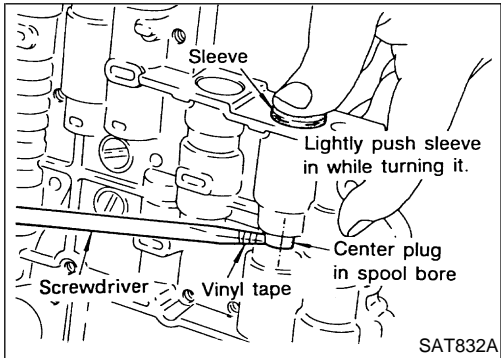

Pressure regulator valve

- If pressure regulator plug is not centered properly, sleeve cannot be inserted into bore in upper body. If this happens, use vinyl tape wrapped screwdriver to center sleeve until it can be inserted.
- Turn sleeve slightly while installing.

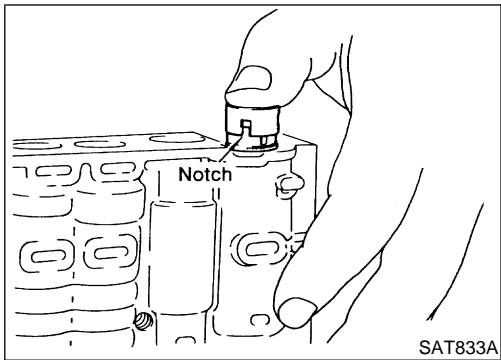

Accumulator control plug

- Align protrusion of accumulator control sleeve with notch in plug.
- Align parallel pin groove in plug with parallel pin, and install accumulator control valve.

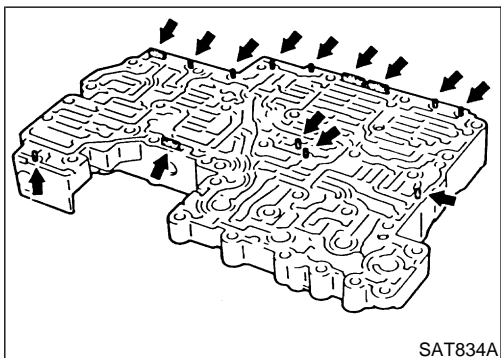

2. Install parallel pins and retainer plates.

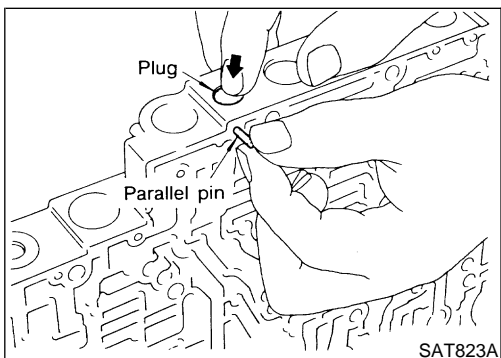

- While pushing plug, install parallel pin.

REPAIR FOR COMPONENT PARTS

Control Valve Upper Body (Cont'd)

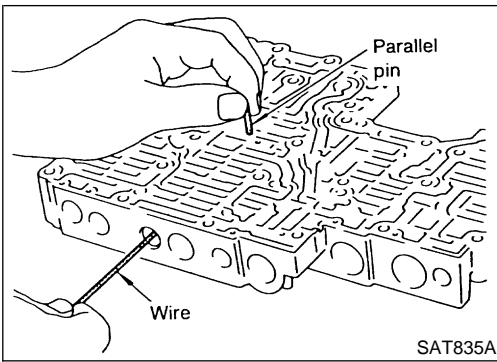

4-2 sequence valve and relay valve

- Push 4-2 sequence valve and relay valve with wire wrapped in vinyl tape to prevent scratching valve body. Install parallel pins.

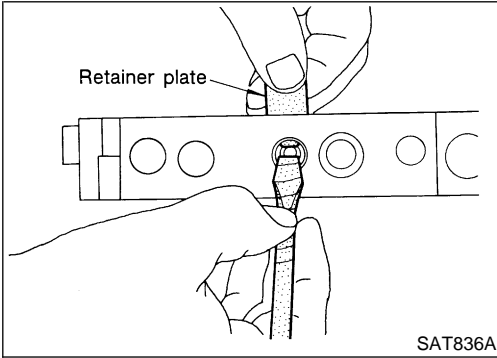

- Insert retainer plate while pushing spring.

GI

MA

EM

LC

EC

FE

CL

MT

AT

TF

PD

AX

SU

BR

ST

RS

BT

HA

SC

EL

IDX

REPAIR FOR COMPONENT PARTS

Control Valve Lower Body

Control Valve Lower Body

COMPONENTS

NGAT0124

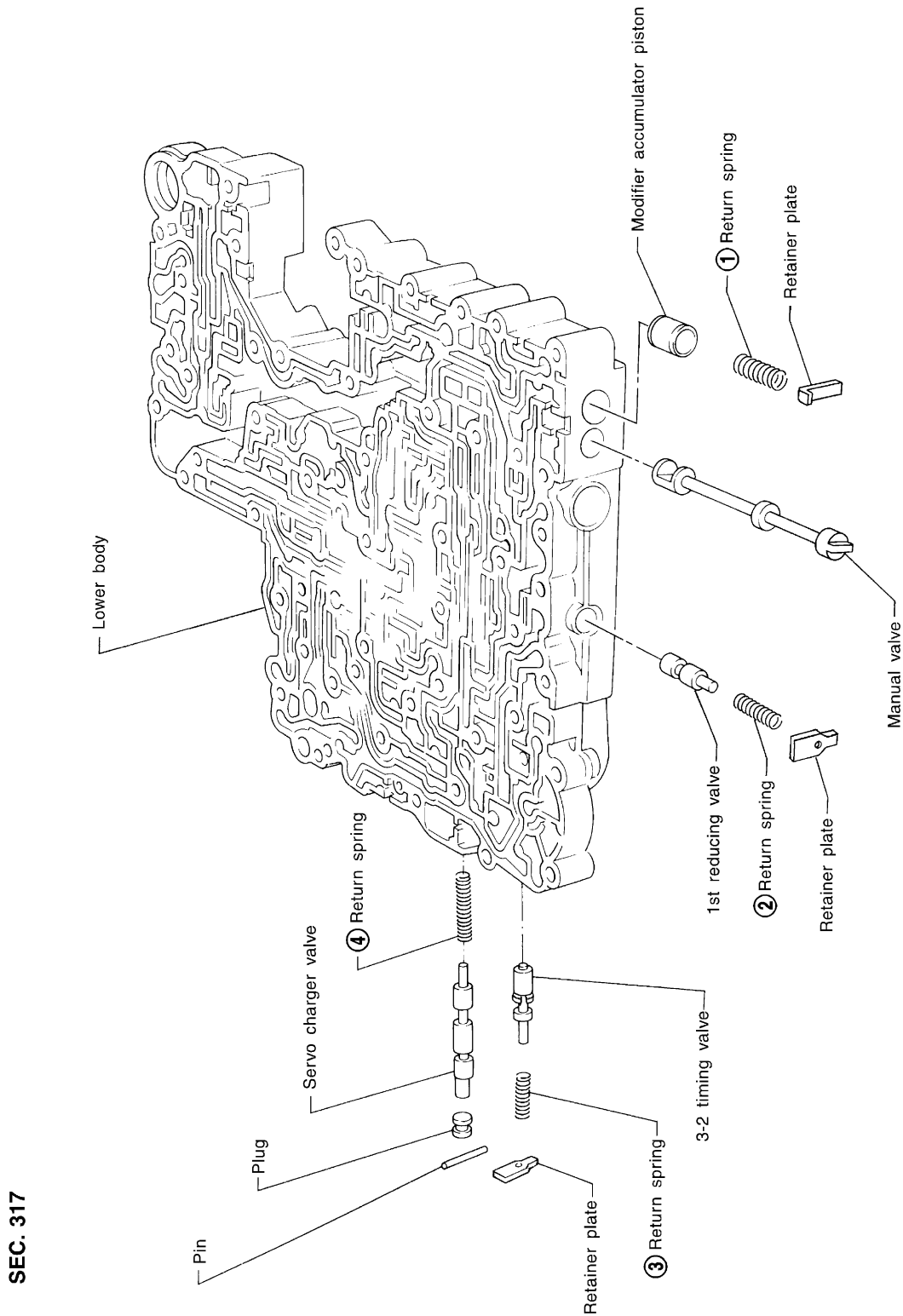

SAT9661

Apply ATF to all components before their installation.
Numbers preceding valve springs correspond with those shown in SDS on page AT-349.

REPAIR FOR COMPONENT PARTS

Control Valve Lower Body (Cont'd)

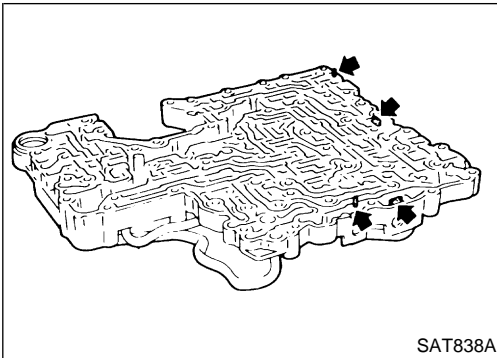

DISASSEMBLY

NGAT0125

1. Remove valves at parallel pins.
2. Remove valves at retainer plates.
For removal procedures, refer to "DISASSEMBLY", AT-300.

GI

MA

EM

LC

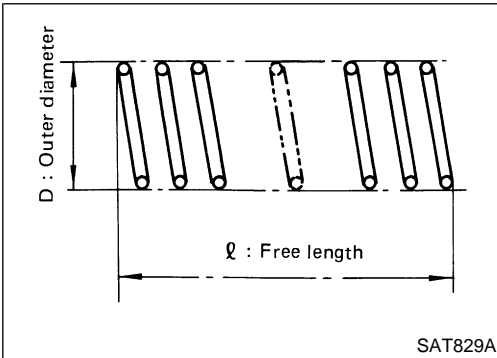

INSPECTION

NGAT0126

Valve Springs

NGAT0126S01

- Check each valve spring for damage or deformation. Also measure free length and outer diameter.

Inspection standard:

Refer to "Return Springs", AT-349.

- Replace valve springs if deformed or fatigued.

EC

FE

CL

Control Valves

NGAT0126S02

- Check sliding surfaces of control valves, sleeves and plugs for damage.

MT

ASSEMBLY

NGAT0127

- Install control valves.
For installation procedures, refer to "ASSEMBLY", AT-301.

AT

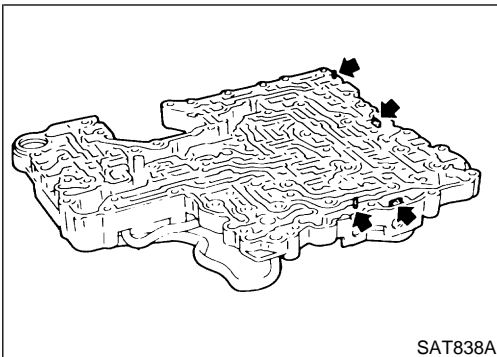

TF

PD

AX

SU

BR

ST

RS

BT

HA

SC

EL

IDX

REPAIR FOR COMPONENT PARTS

Reverse Clutch

Reverse Clutch COMPONENTS

NGAT0128

SEC. 315

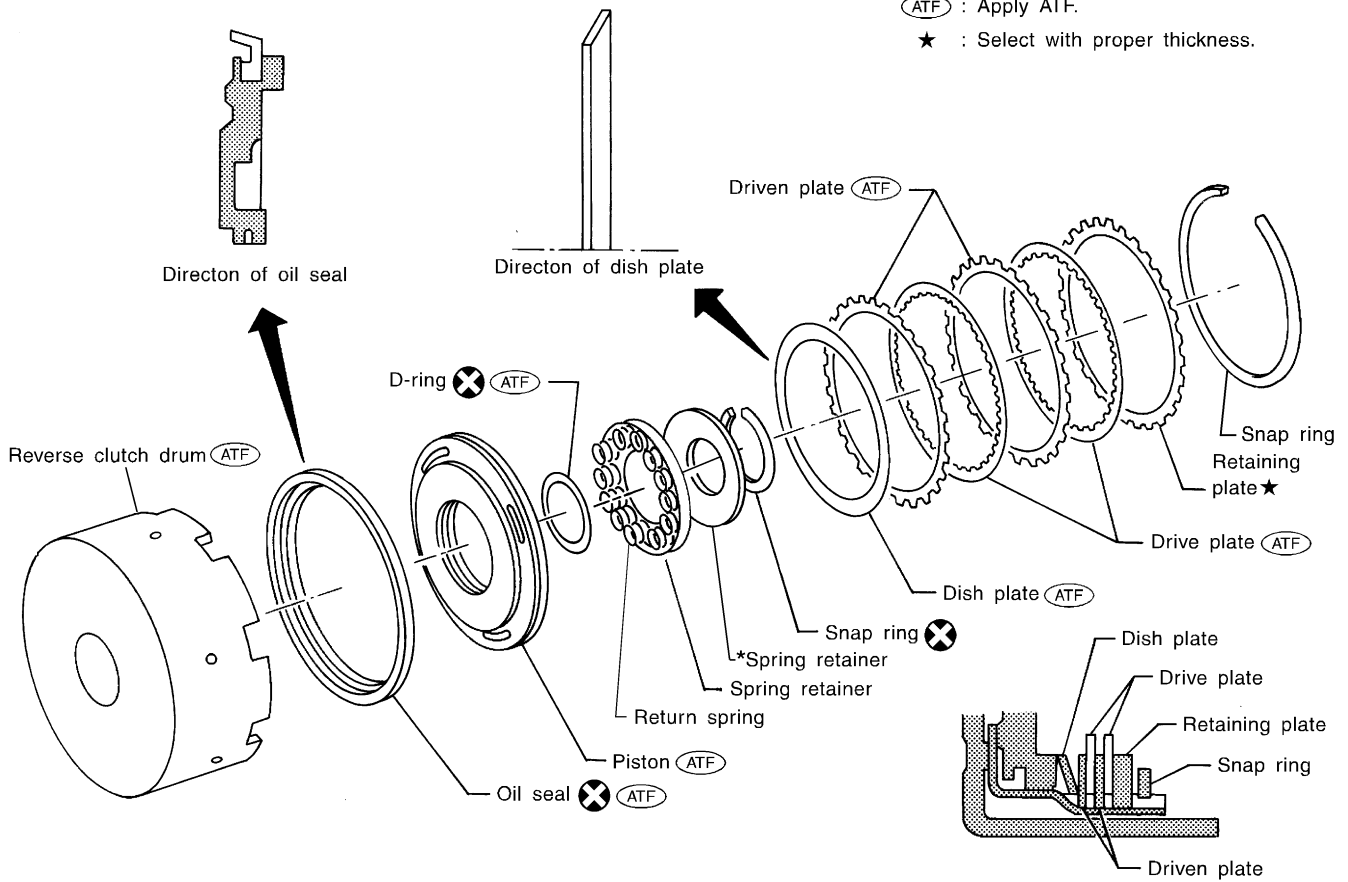

* : VG33ER

LAT441

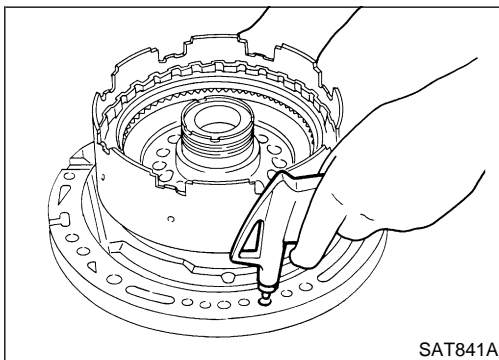

SAT841A

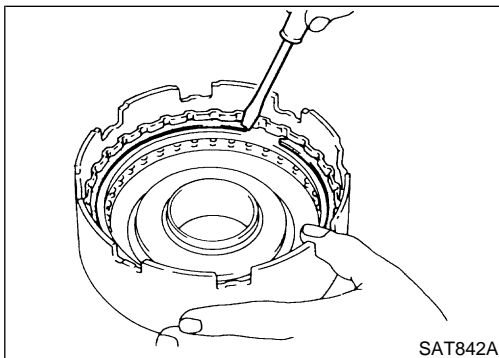

SAT842A

DISASSEMBLY

NGAT0129

1. Check operation of reverse clutch.
 - a. Install seal ring onto oil pump cover and install reverse clutch. Apply compressed air to oil hole.
 - b. Check to see that retaining plate moves to snap ring.
 - c. If retaining plate does not contact snap ring,
 - D-ring might be damaged.
 - Oil seal might be damaged.
 - Fluid might be leaking past piston check ball.
2. Remove drive plates, driven plates, retaining plate, dish plate and snap ring.

REPAIR FOR COMPONENT PARTS

Reverse Clutch (Cont'd)

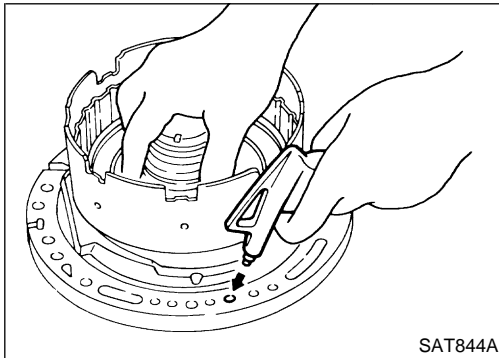
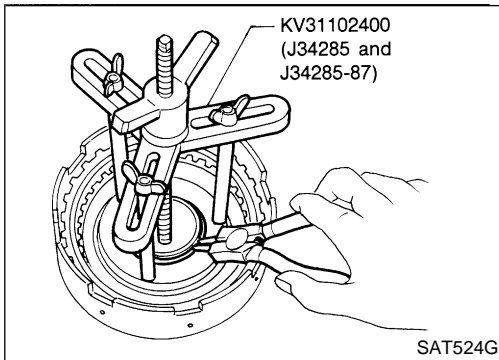

3. Remove snap ring from clutch drum while compressing clutch springs.
 - **Do not expand snap ring excessively.**
4. Remove spring retainer and return spring.
5. Install seal ring onto oil pump cover and install reverse clutch drum. While holding piston, gradually apply compressed air to oil hole until piston is removed.
 - **Do not apply compressed air abruptly.**
6. Remove D-ring and oil seal from piston.

GI
MA
EM
LC
EC
FE
CL
MT

INSPECTION

Reverse Clutch Snap Ring and Spring Retainer

- Check for deformation, fatigue or damage.

NGAT0130
NGAT0130S01

AT

TF

PD

AX

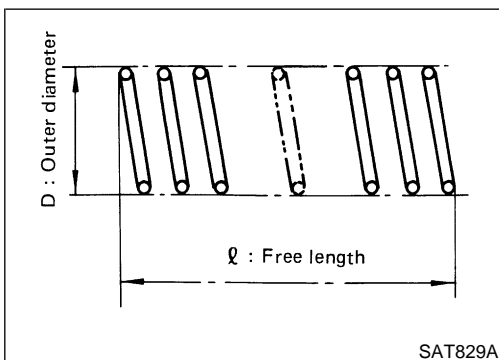

Reverse Clutch Return Springs (VG33E only)

- Check for deformation or damage. Also measure free length and outside diameter.

Inspection standard:

Refer to "Return Springs", AT-349.

NGAT0130S02

SU

BR

ST

RS

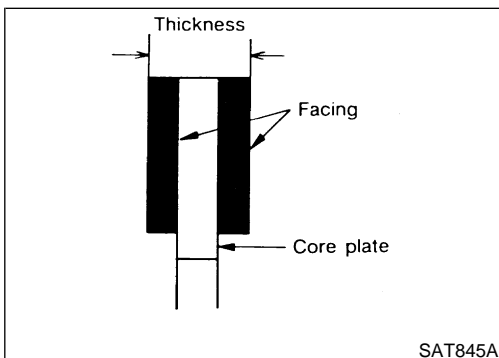

Reverse Clutch Drive Plates

- Check facing for burns, cracks or damage.
- Measure thickness of facing.

Thickness of drive plate:

Standard value: 1.90 - 2.05 mm (0.0748 - 0.0807 in)

Wear limit: 1.80 mm (0.0709 in)

- If not within wear limit, replace.

NGAT0130S03

BT

HA

SC

Reverse Clutch Dish Plate

- Check for deformation or damage.

NGAT0130S04

EL

IDX

REPAIR FOR COMPONENT PARTS

Reverse Clutch (Cont'd)

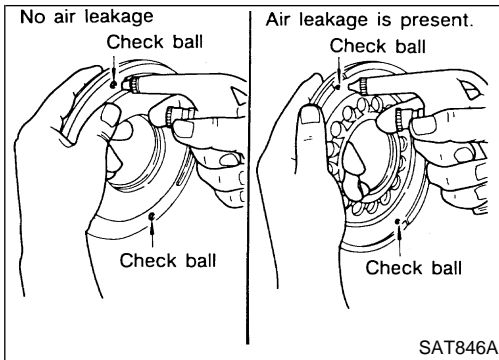

Reverse Clutch Piston

NGAT0130S05

- Shake piston to assure that balls are not seized.
- Apply compressed air to check ball oil hole opposite the return spring. Make sure there is no air leakage.
- Also apply compressed air to oil hole on return spring side to assure that air leaks past ball.

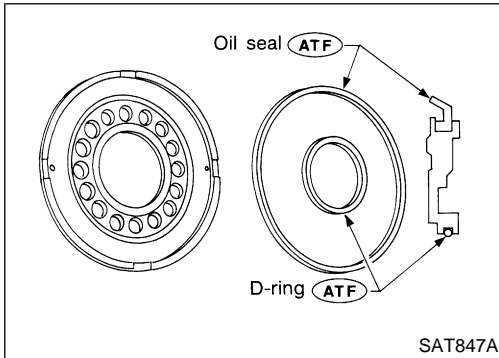

ASSEMBLY

NGAT0131

1. Install D-ring and oil seal on piston.
- **Apply ATF to both parts.**

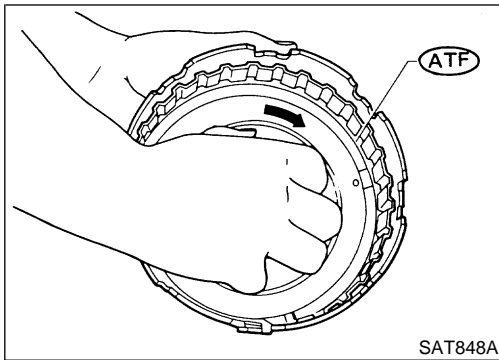

2. Install piston assembly by turning it slowly and evenly.
- **Apply ATF to inner surface of drum.**

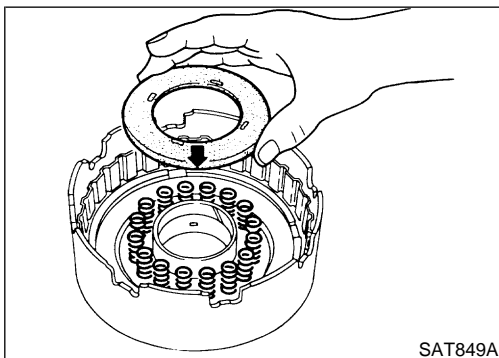

3. Install return springs and spring retainer (VG33E only) or spring retainer (VG33ER only).

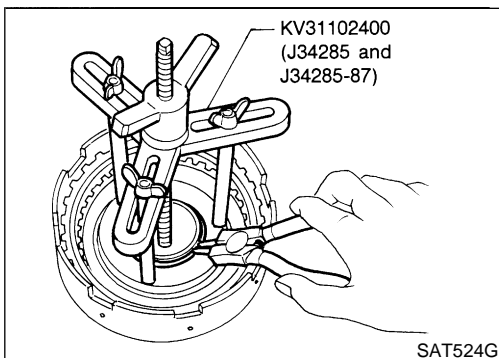

4. Install snap ring while compressing clutch springs.

REPAIR FOR COMPONENT PARTS

Reverse Clutch (Cont'd)

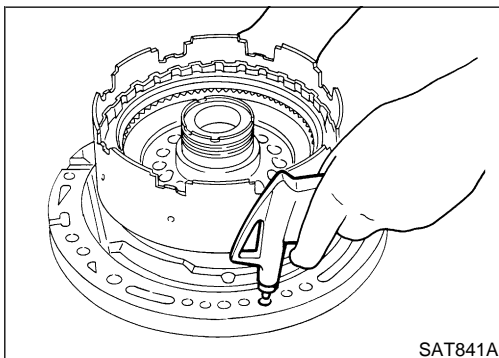
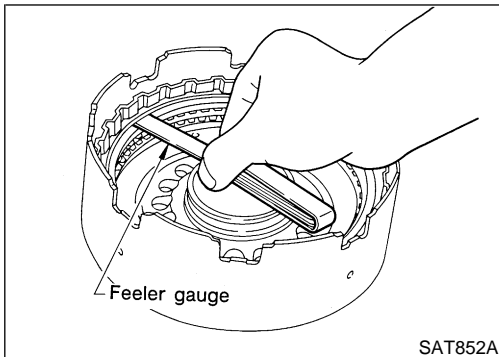
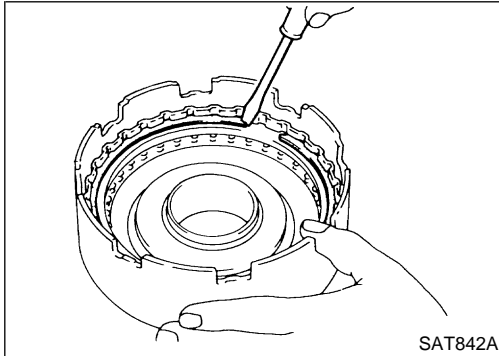
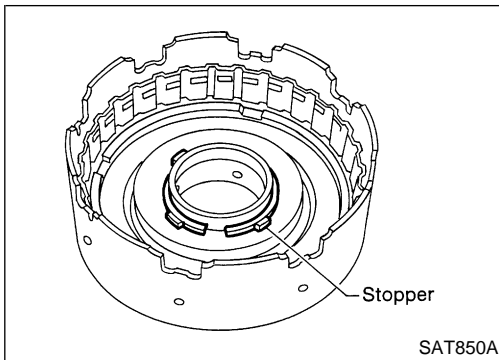

- Do not align snap ring gap with spring retainer stopper.

5. Install drive plates, driven plates, retaining plate and dish plate.
6. Install snap ring.

7. Measure clearance between retaining plate and snap ring. If not within allowable limit, select proper retaining plate.

Specified clearance:

Standard

0.5 - 0.8 mm (0.020 - 0.031 in)

Allowable limit

1.2 mm (0.047 in)

Retaining plate:

Refer to "REVERSE CLUTCH", AT-350.

8. Check operation of reverse clutch.
Refer to "DISASSEMBLY", AT-306.

GI

MA

EM

LC

EC

FE

CL

MT

AT

TF

PD

AX

SU

BR

ST

RS

BT

HA

SC

EL

IDX

REPAIR FOR COMPONENT PARTS

High Clutch

High Clutch COMPONENTS

NGAT0132

SEC. 315

For the number of clutch sheets (drive plate and driven plate), refer to the below cross-section.

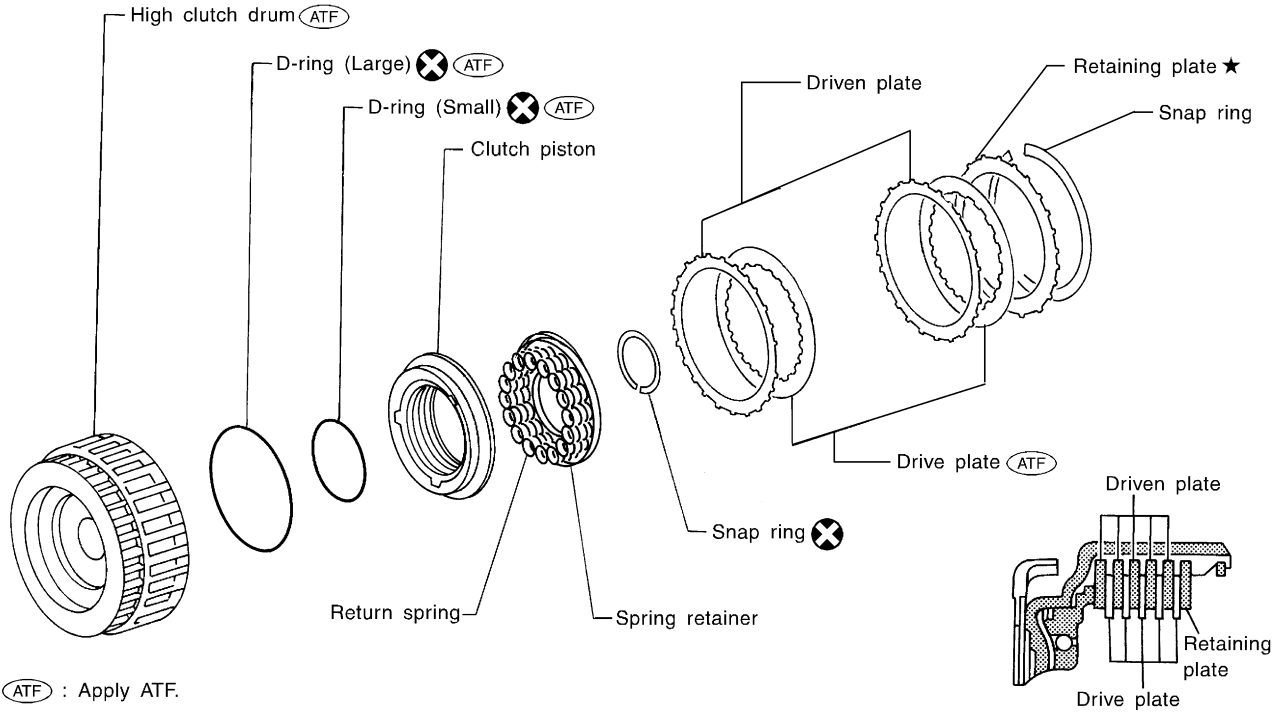

(ATF) : Apply ATF.

★ : Select with proper thickness.

LAT437

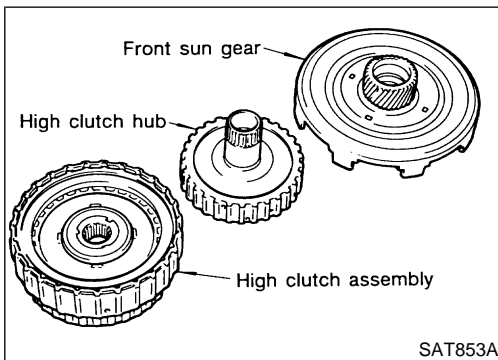

SAT853A

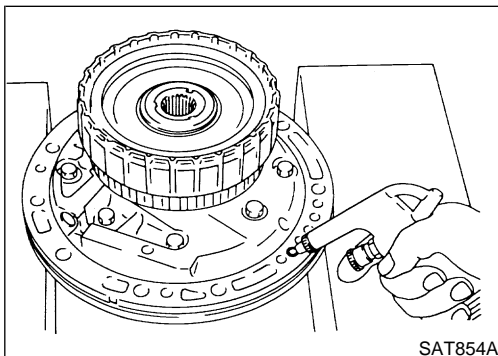

SAT854A

DISASSEMBLY AND ASSEMBLY

NGAT0133

Service procedures for high clutch are essentially the same as those for reverse clutch, with the following exception:

- Check of high clutch operation

REPAIR FOR COMPONENT PARTS

High Clutch (Cont'd)

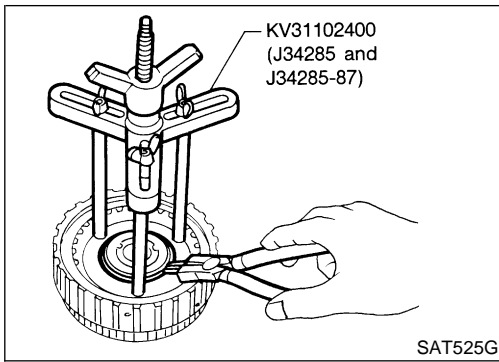

- Removal and installation of return spring

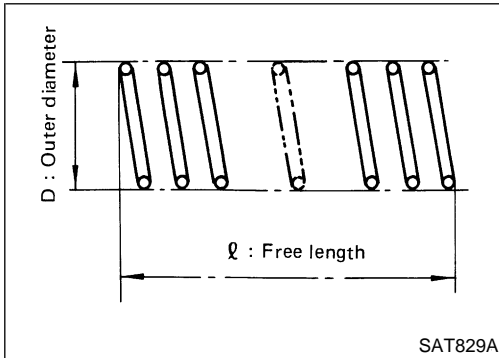

- Inspection of high clutch return springs
Inspection standard:
Refer to "Return Springs", AT-349.

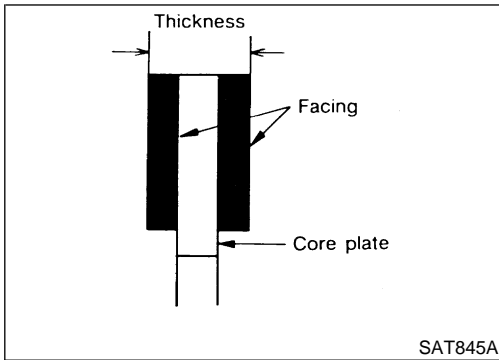

- Inspection of high clutch drive plate
Thickness of drive plate:
Standard
1.52 - 1.67 mm (0.0598 - 0.0657 in)
Wear limit
1.40 mm (0.0551 in)

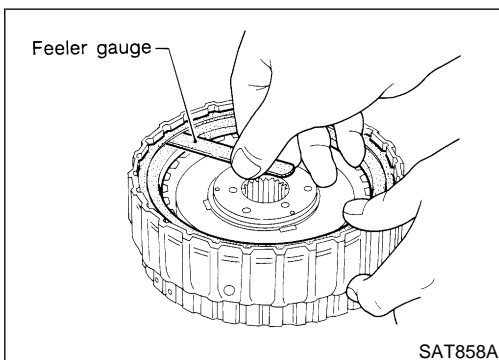

- Measurement of clearance between retaining plate and snap ring
Specified clearance:
Standard
1.8 - 2.2 mm (0.071 - 0.087 in)
Allowable limit
VG33E only: 2.8 mm (0.110 in)
VG33ER only: 2.2 mm (0.087 in)
Retaining plate:
Refer to "HIGH CLUTCH", AT-351.

GI

MA

EM

LC

EC

FE

CL

MT

AT

TF

PD

AX

SU

BR

ST

RS

BT

HA

SC

EL

IDX

REPAIR FOR COMPONENT PARTS

Forward and Overrun Clutches COMPONENTS

NGAT0134

SEC. 315

For the number of clutch sheets (drive plate and driven plate), refer to the below cross-section.

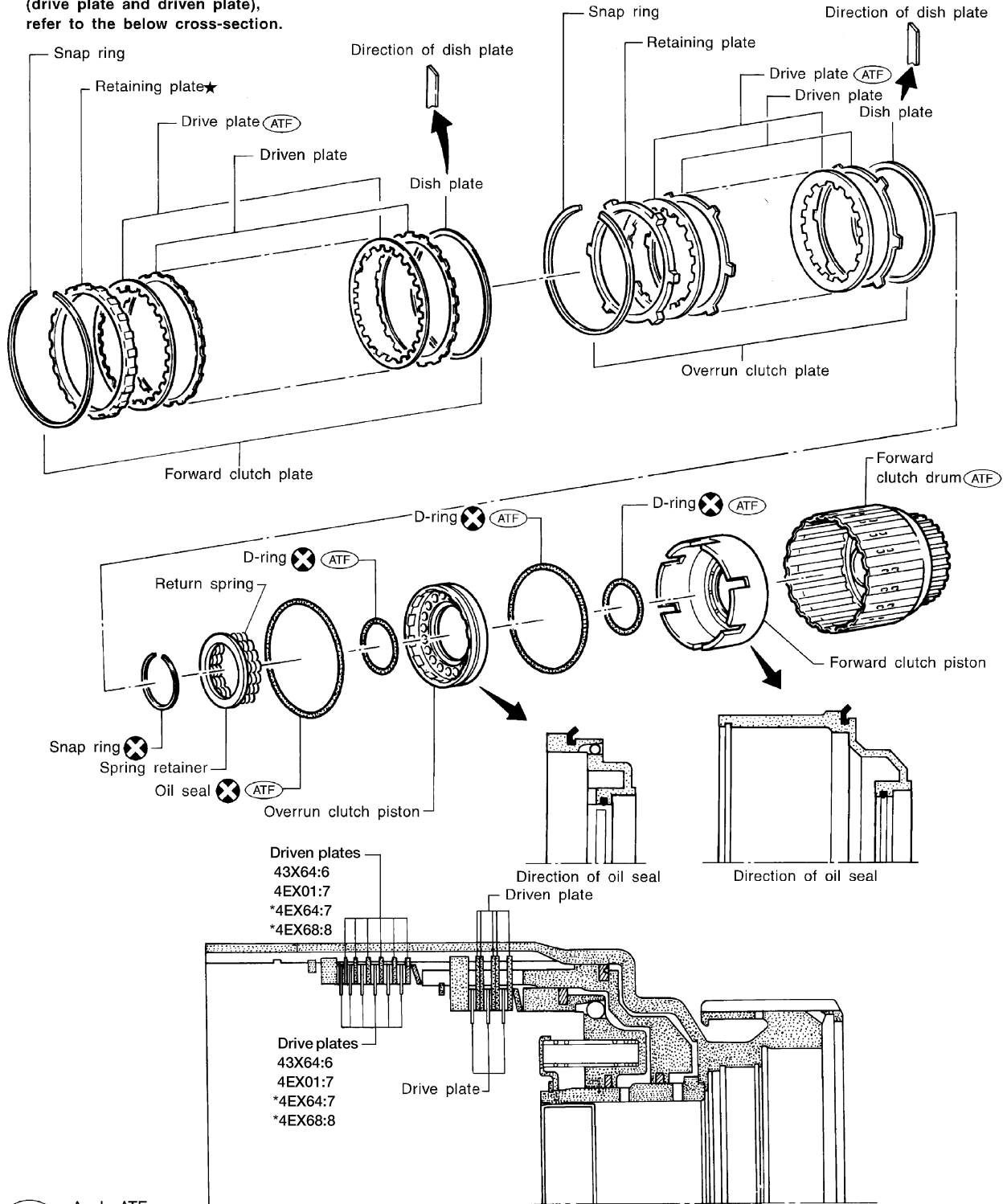

(ATF) : Apply ATF.

★ : Select with proper thickness.

* VG33ER only

REPAIR FOR COMPONENT PARTS

Forward and Overrun Clutches (Cont'd)

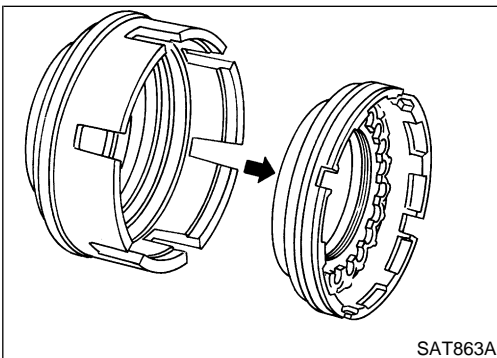
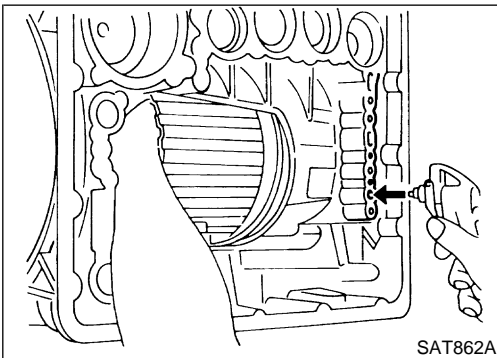
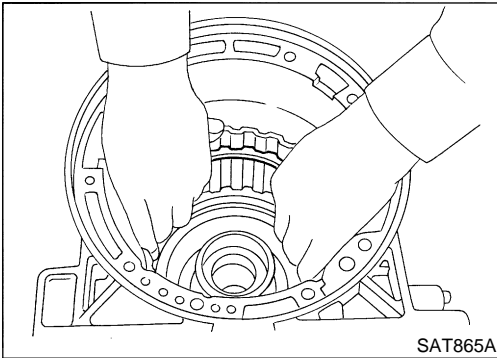
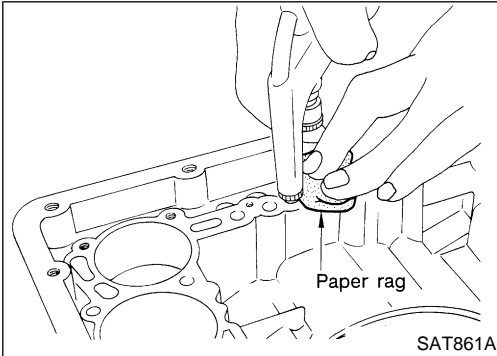
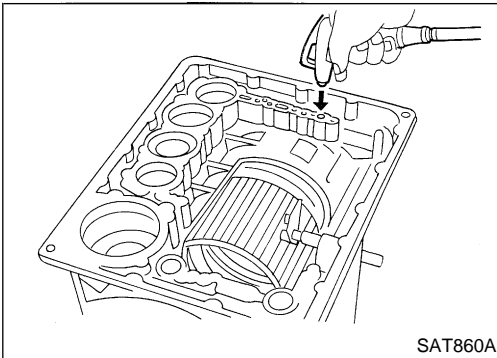

DISASSEMBLY AND ASSEMBLY

NGAT0135

Forward and overrun clutches are serviced essentially the same way as reverse clutch is serviced. However, note the following exceptions.

- Check of forward clutch operation

- Check of overrun clutch operation

- Removal of forward clutch drum
Remove forward clutch drum from transmission case by holding snap ring.

- Removal of forward clutch and overrun clutch pistons
a) While holding overrun clutch piston, gradually apply compressed air to oil hole.

- b) Remove overrun clutch from forward clutch.

GI

MA

EM

LC

EC

FE

CL

MT

AT

TF

PD

AX

SU

BR

ST

RS

BT

HA

SC

EL

IDX

REPAIR FOR COMPONENT PARTS

Forward and Overrun Clutches (Cont'd)

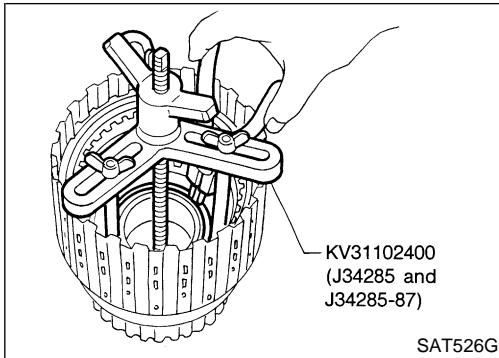

- Removal and installation of return springs

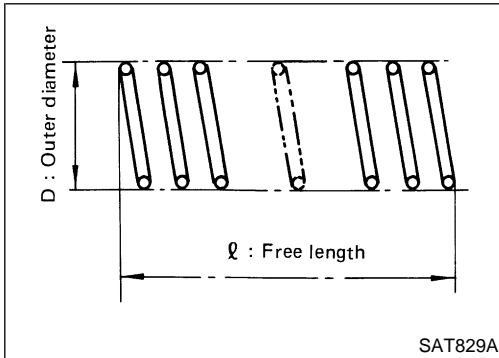

- Inspection of forward clutch and overrun clutch return springs

Inspection standard:

Refer to “Return Springs”, AT-349.

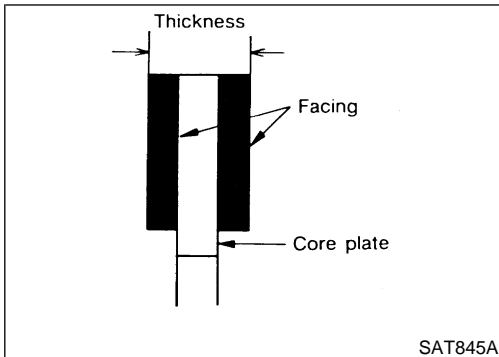

- Inspection of forward clutch drive plates

Thickness of drive plate:

Standard

1.52 - 1.67 mm (0.0598 - 0.0657 in)

Wear limit

1.40 mm (0.0551 in)

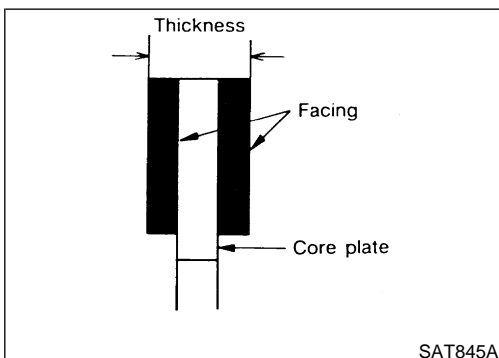

- Inspection of overrun clutch drive plates

Thickness of drive plate:

Standard

1.90 - 2.05 mm (0.0748 - 0.0807 in)

Wear limit

1.80 mm (0.0709 in)

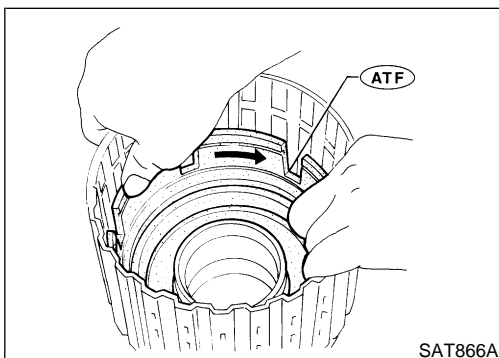

- Installation of forward clutch piston and overrun clutch piston
- a) Install forward clutch piston by turning it slowly and evenly.
- **Apply ATF to inner surface of clutch drum.**

REPAIR FOR COMPONENT PARTS

Forward and Overrun Clutches (Cont'd)

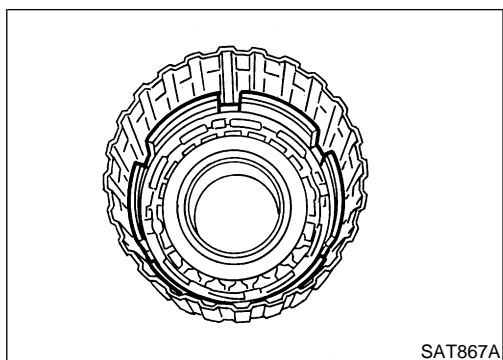

- Align notch in forward clutch piston with groove in forward clutch drum.

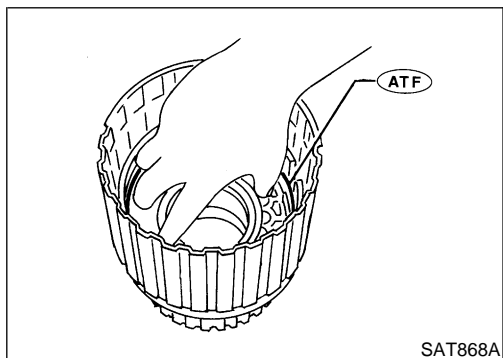

- b) Install overrun clutch by turning it slowly and evenly.
- Apply ATF to inner surface of forward clutch piston.

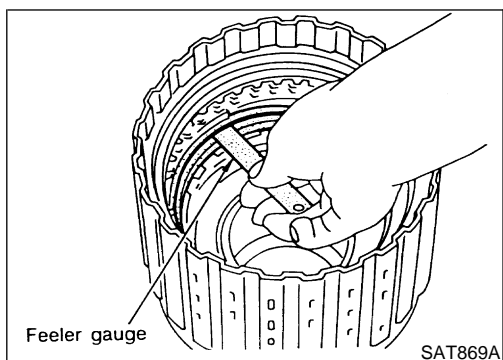

- Measurement of clearance between retaining plate and snap ring of overrun clutch

Specified clearance:

Standard

1.0 - 1.4 mm (0.039 - 0.055 in)

Allowable limit

VG33E only: 2.0 mm (0.079 in)

VG33ER only: 2.4 mm (0.094 in)

Retaining plate:

Refer to "FORWARD CLUTCH", AT-352.

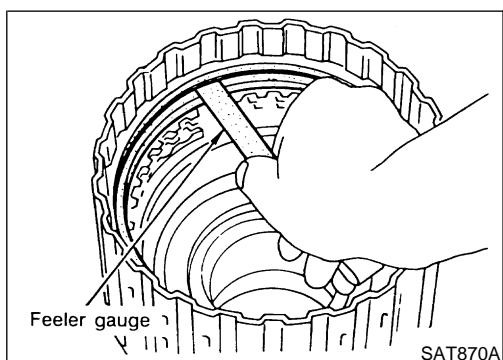

- Measurement of clearance between retaining plate and snap ring of forward clutch

Specified clearance:

Standard

0.35 - 0.75 mm (0.0138 - 0.0295 in)

Allowable limit

VG33E only: Model 43X64 (2WD) 1.95 mm (0.077 in)

VG33E only: Model 4EX01, 4FX06 (4WD) 2.15 mm (0.085 in)

VG33ER only: Model 4EX67 (2WD) 2.15 mm (0.085 in)

VG33ER only: Model 4EX68, 4FX07 (4WD) 2.35 mm (0.093 in)

Retaining plate:

Refer to "FORWARD CLUTCH", AT-351.

GI

MA

EM

LC

EC

FE

CL

MT

AT

TF

PD

AX

SU

BR

ST

RS

BT

HA

SC

EL

IDX

REPAIR FOR COMPONENT PARTS

Low & Reverse Brake

Low & Reverse Brake COMPONENTS

NGAT0136

SEC. 315

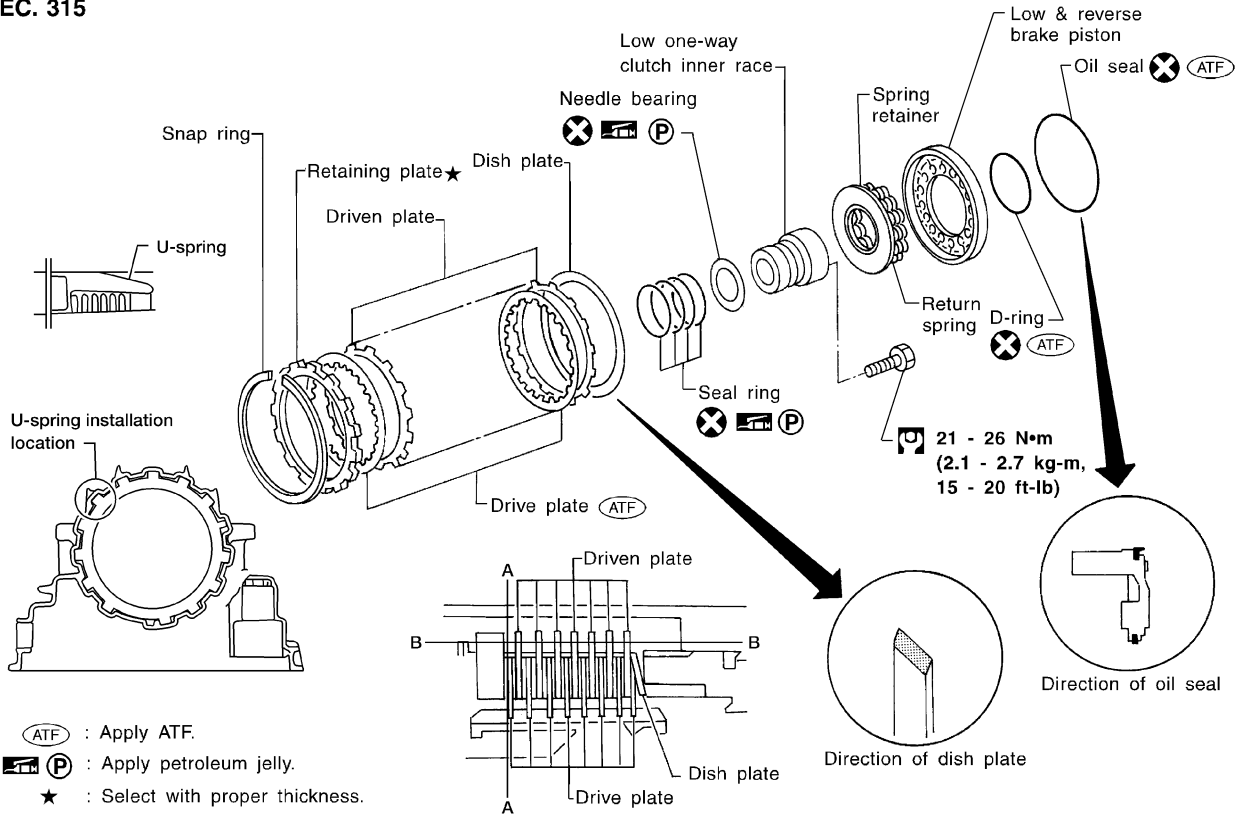

LAT423

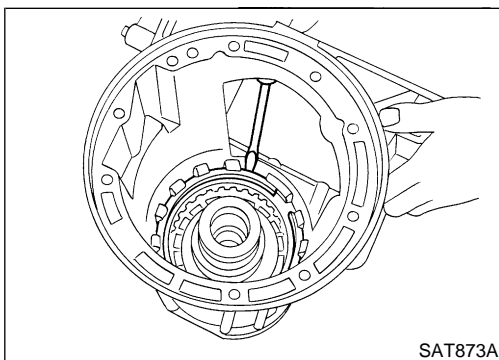
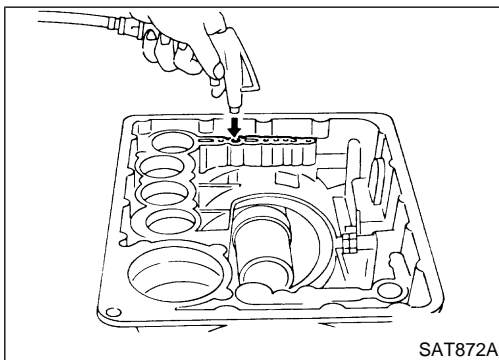

DISASSEMBLY

NGAT0137

1. Check operation of low and reverse brake.
 - a. Install seal ring onto oil pump cover and install reverse clutch. Apply compressed air to oil hole.
 - b. Check to see that retaining plate moves to snap ring.
 - c. If retaining plate does not contact snap ring,
 - D-ring might be damaged.
 - Oil seal might be damaged.
 - Fluid might be leaking past piston check ball.
2. Remove snap ring, low and reverse brake drive plates, driven plates and dish plate.

REPAIR FOR COMPONENT PARTS

Low & Reverse Brake (Cont'd)

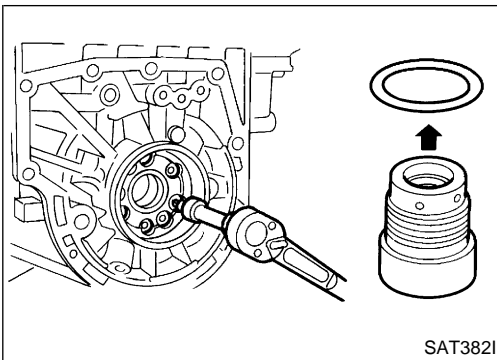

SAT382I

3. Remove low one-way clutch inner race, spring retainer and return spring from transmission case.
4. Remove seal rings from low one-way clutch inner race.
5. Remove needle bearing from low one-way clutch inner race.

GI

MA

EM

LC

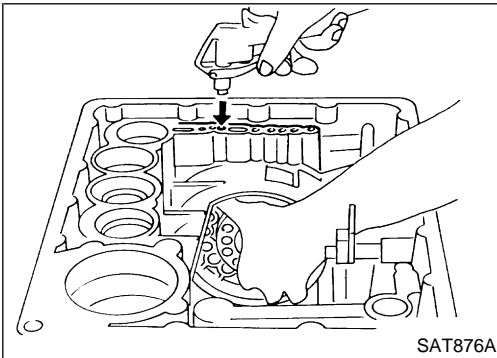

SAT876A

6. Remove low and reverse brake piston using compressed air.
7. Remove oil seal and D-ring from piston.

EC

FE

CL

MT

INSPECTION

Low and Reverse Brake Snap Ring and Spring Retainer NGAT0138 NGAT0138S01

AT

- Check for deformation, or damage.

TF

PD

AX

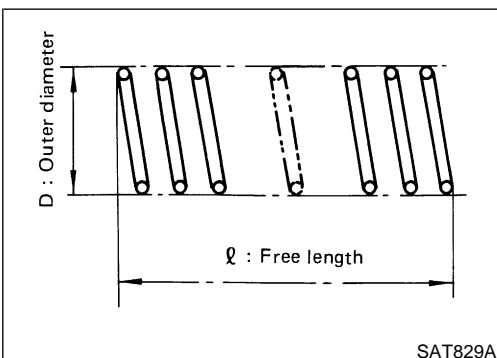

SAT829A

Low and Reverse Brake Return Springs

NGAT0138S02

- Check for deformation or damage. Also measure free length and outside diameter.

Inspection standard:

Refer to "Return Springs", AT-349.

SU

BR

ST

RS

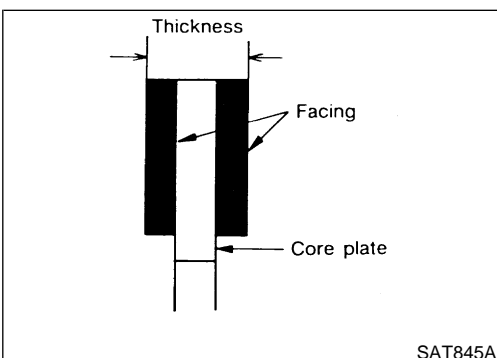

SAT845A

Low and Reverse Brake Drive Plates

NGAT0138S03

- Check facing for burns, cracks or damage.
- Measure thickness of facing.

Thickness of drive plate:

Standard value

1.52 - 1.67 mm (0.0598 - 0.0657 in)

Wear limit

1.40 mm (0.0551 in)

- If not within wear limit, replace.

BT

HA

SC

EL

IDX

REPAIR FOR COMPONENT PARTS

Low & Reverse Brake (Cont'd)

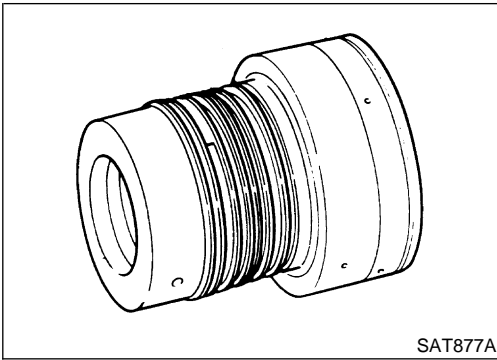

Low One-way Clutch Inner Race

NGAT0138S04

- Check frictional surface of inner race for wear or damage.

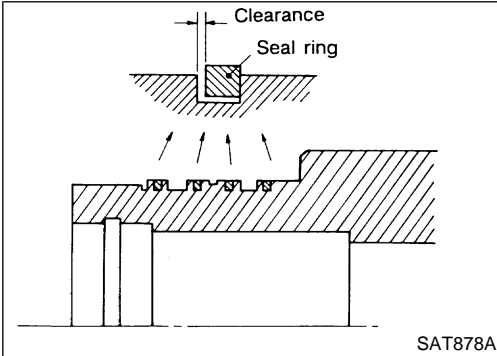

- Install a new seal rings onto low one-way clutch inner race.
- **Be careful not to expand seal ring gap excessively.**
- Measure seal ring-to-groove clearance.

Inspection standard:

Standard value: 0.10 - 0.25 mm (0.0039 - 0.0098 in)

Allowable limit: 0.25 mm (0.0098 in)

- If not within allowable limit, replace low one-way clutch inner race.

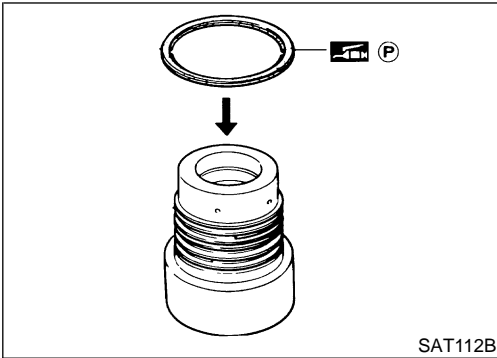

ASSEMBLY

NGAT0139

1. Install needle bearing onto one-way clutch inner race.
 - **Pay attention to its direction — Black surface goes to rear side.**
 - **Apply petroleum jelly to needle bearing.**

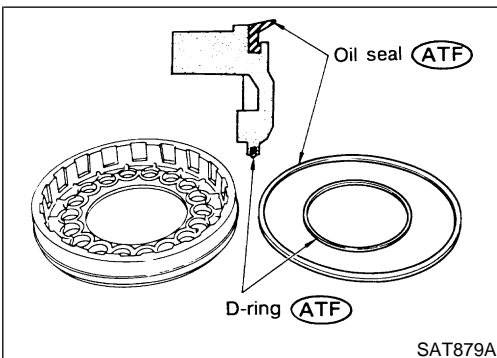

2. Install oil seal and D-ring onto piston.
 - **Apply ATF to oil seal and D-ring.**

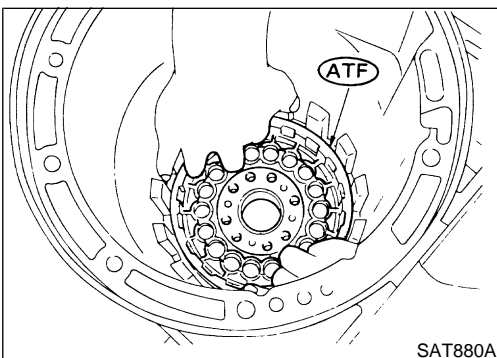

3. Install piston by rotating it slowly and evenly.
 - **Apply ATF to inner surface of transmission case.**

REPAIR FOR COMPONENT PARTS

Low & Reverse Brake (Cont'd)

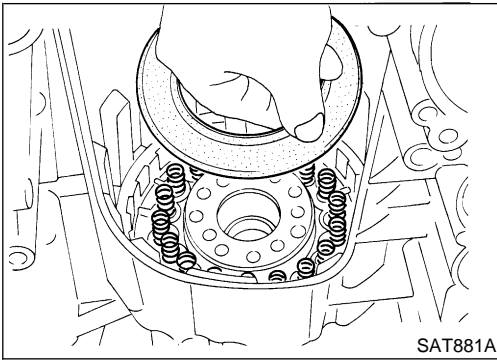

4. Install return springs, spring retainer and low one-way clutch inner race onto transmission case.
5. Install dish plate, low and reverse brake drive plates, driven plates and retaining plate.
6. Install snap ring on transmission case.

GI
MA

EM

LC

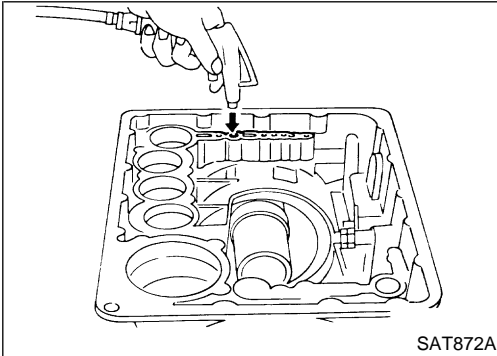

7. Check operation of low and reverse brake clutch piston. Refer to "DISASSEMBLY", AT-316.

EC

FE

CL

MT

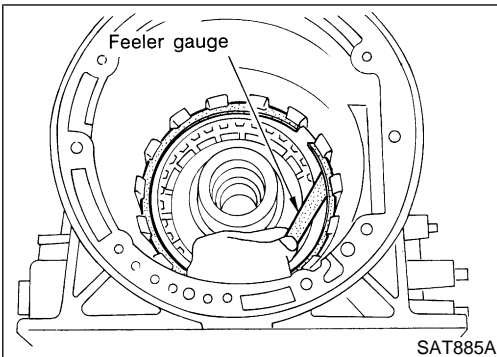

8. Measure clearance between retaining plate and snap ring. If not within allowable limit, select proper retaining plate.

Specified clearance:

Standard

0.8 - 1.1 mm (0.031 - 0.043 in)

Allowable limit

VG33E only: 2.5 mm (0.098 in)

VG33ER only: 2.7 mm (0.106 in)

Retaining plate:

Refer to "LOW & REVERSE BRAKE", AT-352.

AT

TF

PD

AX

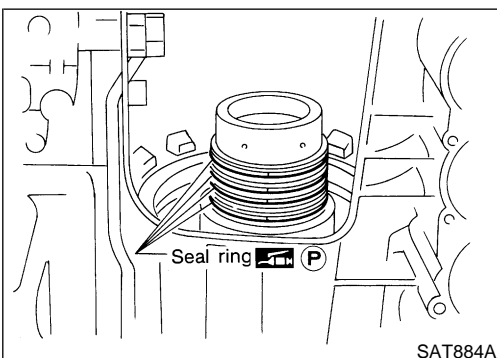

9. Install low one-way clutch inner race seal ring.
 - Apply petroleum jelly to seal ring.
 - Make sure seal rings are pressed firmly into place and held by petroleum jelly.

SU

BR

ST

RS

BT

HA

SC

EL

IDX

REPAIR FOR COMPONENT PARTS

Forward Clutch Drum Assembly

Forward Clutch Drum Assembly COMPONENTS

NGAT0140

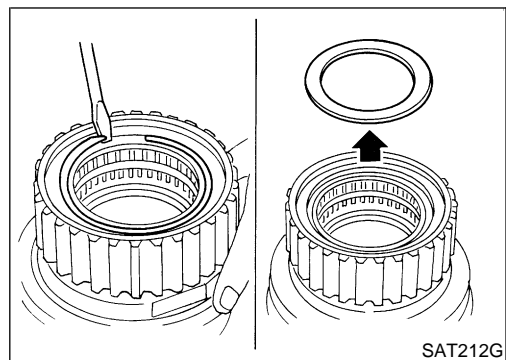
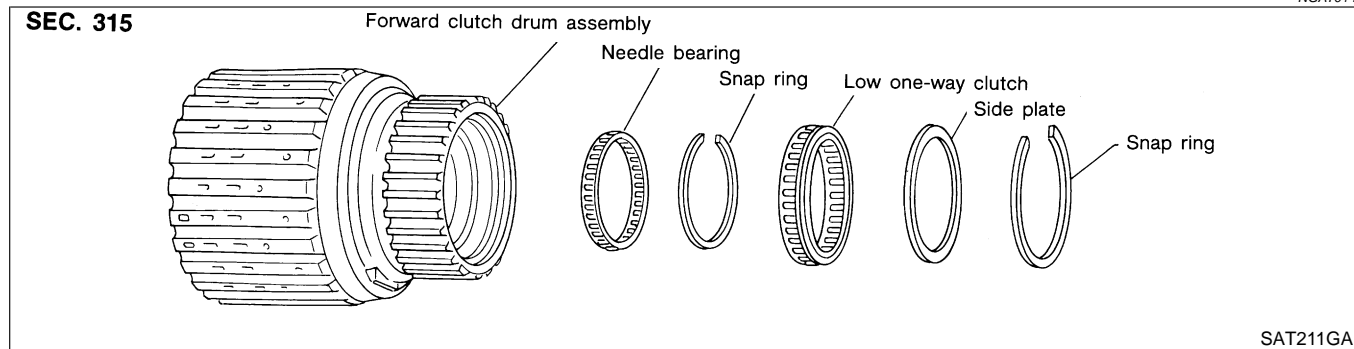

DISASSEMBLY

NGAT0141

1. Remove snap ring from forward clutch drum.
2. Remove side plate from forward clutch drum.

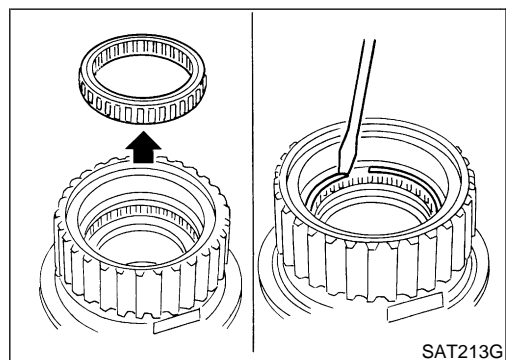

3. Remove low one-way clutch from forward clutch drum.
4. Remove snap ring from forward clutch drum.

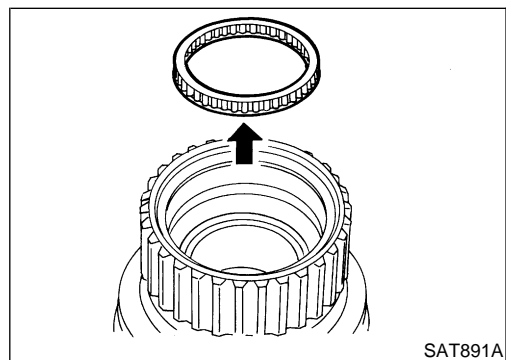

5. Remove needle bearing from forward clutch drum.

REPAIR FOR COMPONENT PARTS

Forward Clutch Drum Assembly (Cont'd)

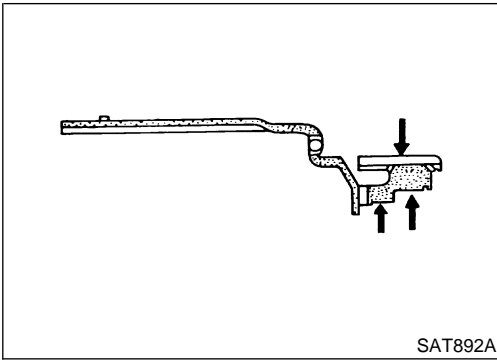

INSPECTION

Forward Clutch Drum

NGAT0142

NGAT0142S01

- Check spline portion for wear or damage.
- Check frictional surfaces of low one-way clutch and needle bearing for wear or damage.

GI

MA

EM

LC

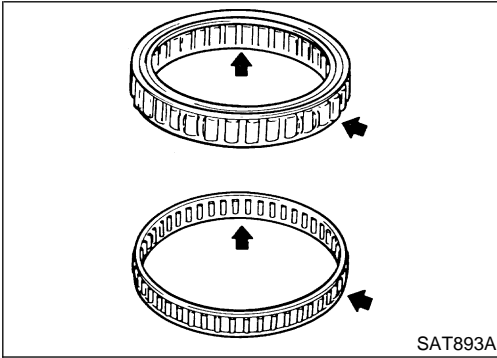

Needle Bearing and Low One-way Clutch

NGAT0142S02

- Check frictional surface for wear or damage.

EC

FE

CL

MT

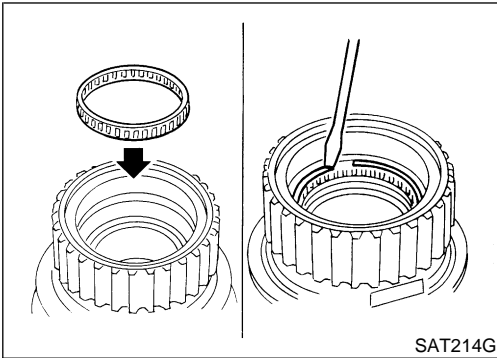

ASSEMBLY

NGAT0143

1. Install needle bearing in forward clutch drum.
2. Install snap ring onto forward clutch drum.

AT

TF

PD

AX

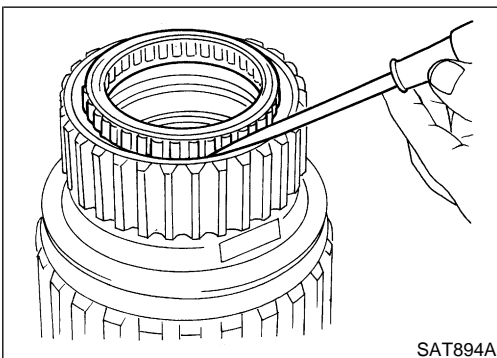

3. Install low one-way clutch onto forward clutch drum by pushing the roller in evenly.

SU

BR

ST

RS

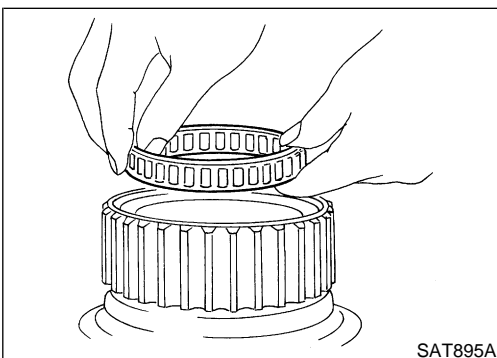

- Install low one-way clutch with flange facing rearward.

BT

HA

SC

EL

IDX

REPAIR FOR COMPONENT PARTS

Forward Clutch Drum Assembly (Cont'd)

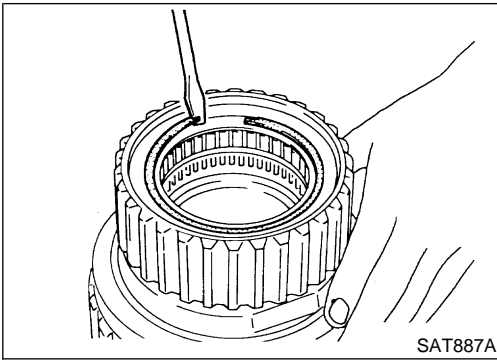

4. Install side plate onto forward clutch drum.
5. Install snap ring onto forward clutch drum.

Rear Internal Gear and Forward Clutch Hub COMPONENTS

NGAT0144

SEC. 315

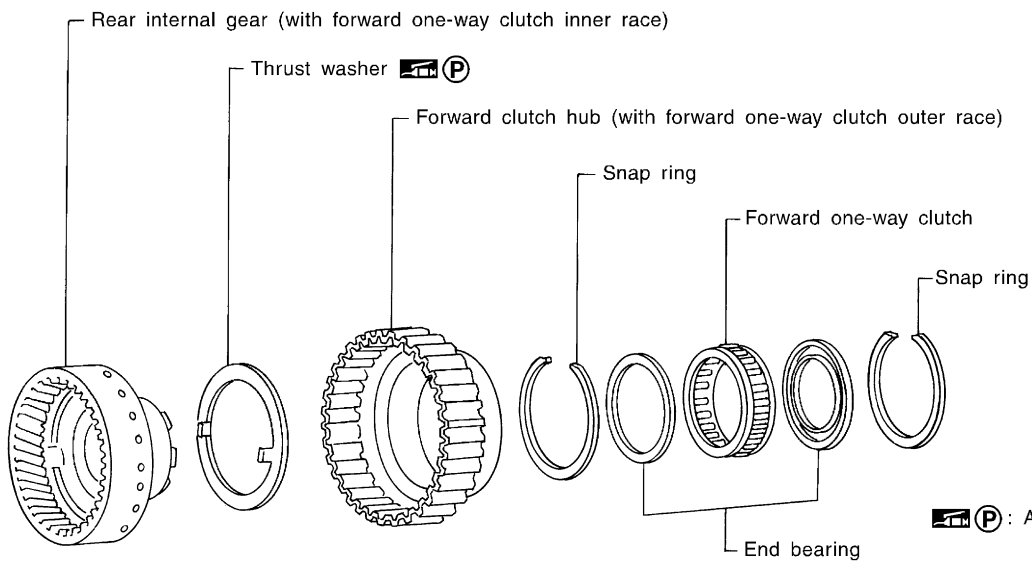

SAT896AA

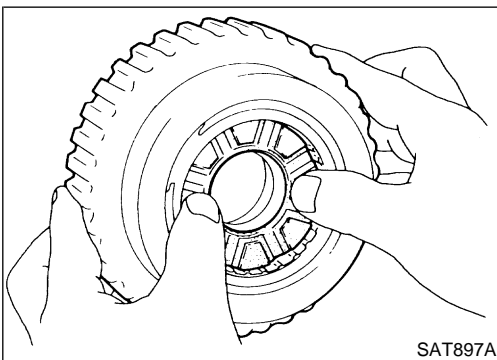

SAT897A

DISASSEMBLY

1. Remove rear internal gear by pushing forward clutch hub forward.

NGAT0145

2. Remove thrust washer from rear internal gear.

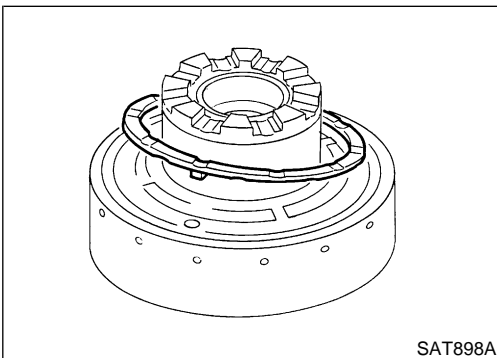

SAT898A

REPAIR FOR COMPONENT PARTS

Rear Internal Gear and Forward Clutch Hub (Cont'd)

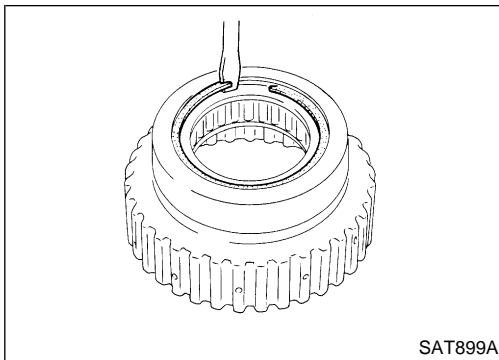

3. Remove snap ring from forward clutch hub.

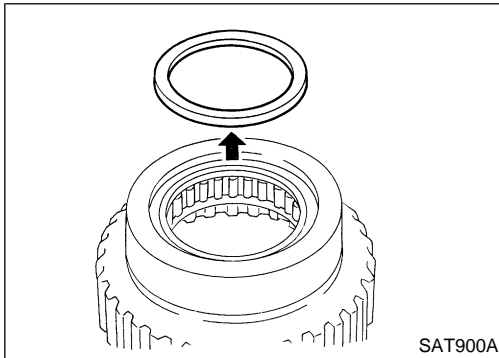

4. Remove end bearing.

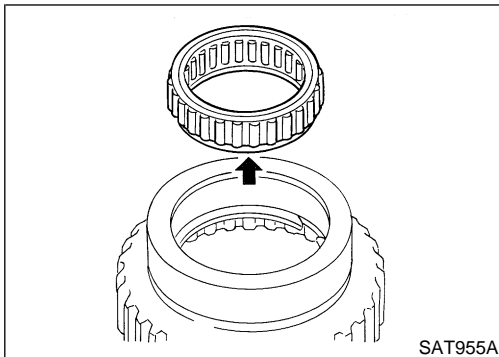

5. Remove forward one-way clutch and end bearing as a unit from forward clutch hub.

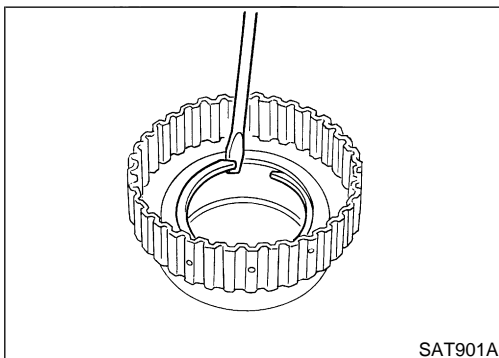

6. Remove snap ring from forward clutch hub.

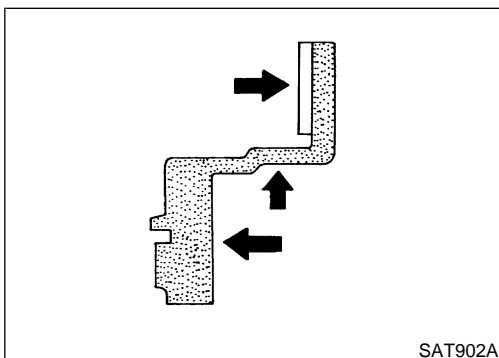

INSPECTION

Rear Internal Gear and Forward Clutch Hub

- Check gear for excessive wear, chips or cracks.
- Check frictional surfaces of forward one-way clutch and thrust washer for wear or damage.
- Check spline for wear or damage.

NGAT0146

NGAT0146S01

GI

MA

EM

LC

EC

FE

CL

MT

AT

TF

PD

AX

SU

BR

ST

RS

BT

HA

SC

EL

IDX

REPAIR FOR COMPONENT PARTS

Rear Internal Gear and Forward Clutch Hub (Cont'd)

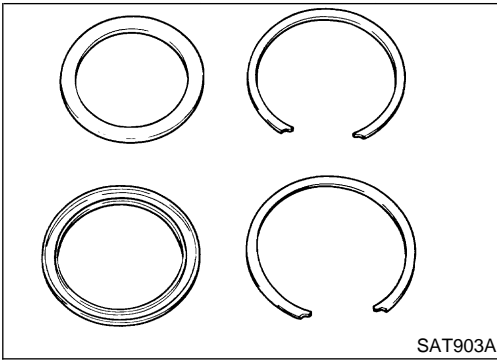

Snap Ring and End Bearing

NGAT0146S02

- Check for deformation or damage.

ASSEMBLY

NGAT0147

1. Install snap ring onto forward clutch hub.

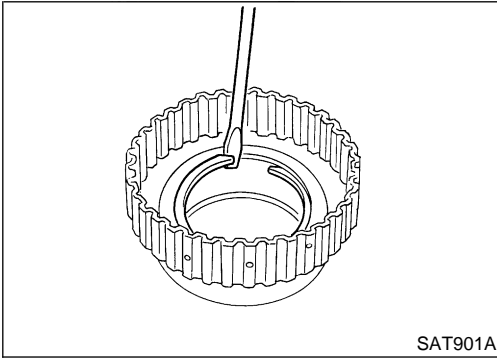

2. Install end bearing.

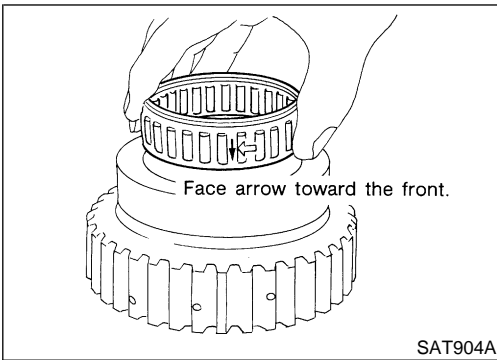

3. Install forward one-way clutch onto clutch hub.

- **Install forward one-way clutch with flange facing rearward.**

4. Install end bearing.

5. Install snap ring onto forward clutch hub.

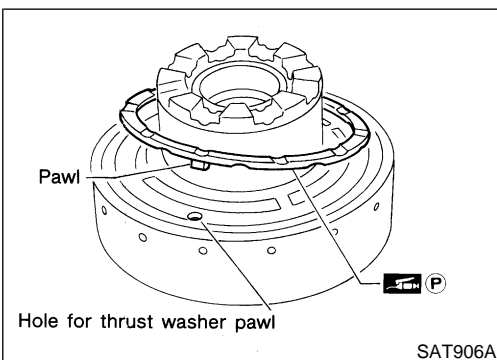

6. Install thrust washer onto rear internal gear.

- **Apply petroleum jelly to thrust washer.**

- **Securely insert pawls of thrust washer into holes in rear internal gear.**

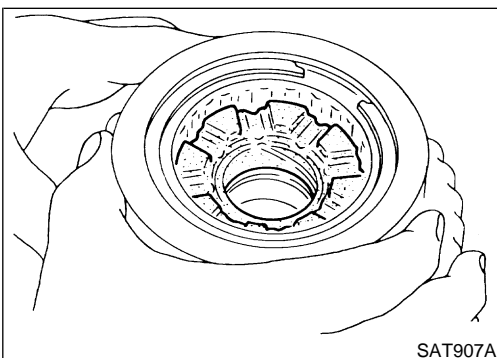

7. Position forward clutch hub in rear internal gear.

REPAIR FOR COMPONENT PARTS

Rear Internal Gear and Forward Clutch Hub (Cont'd)

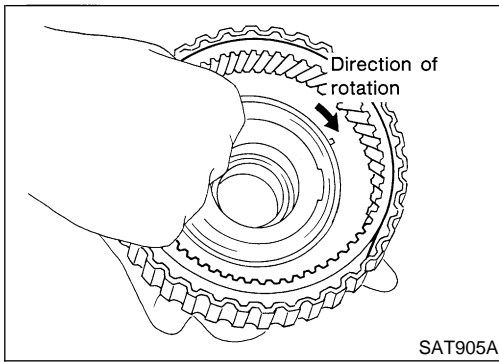

SAT905A

- After installing, check to assure that forward clutch hub rotates clockwise.

Band Servo Piston Assembly COMPONENTS

NGAT0148

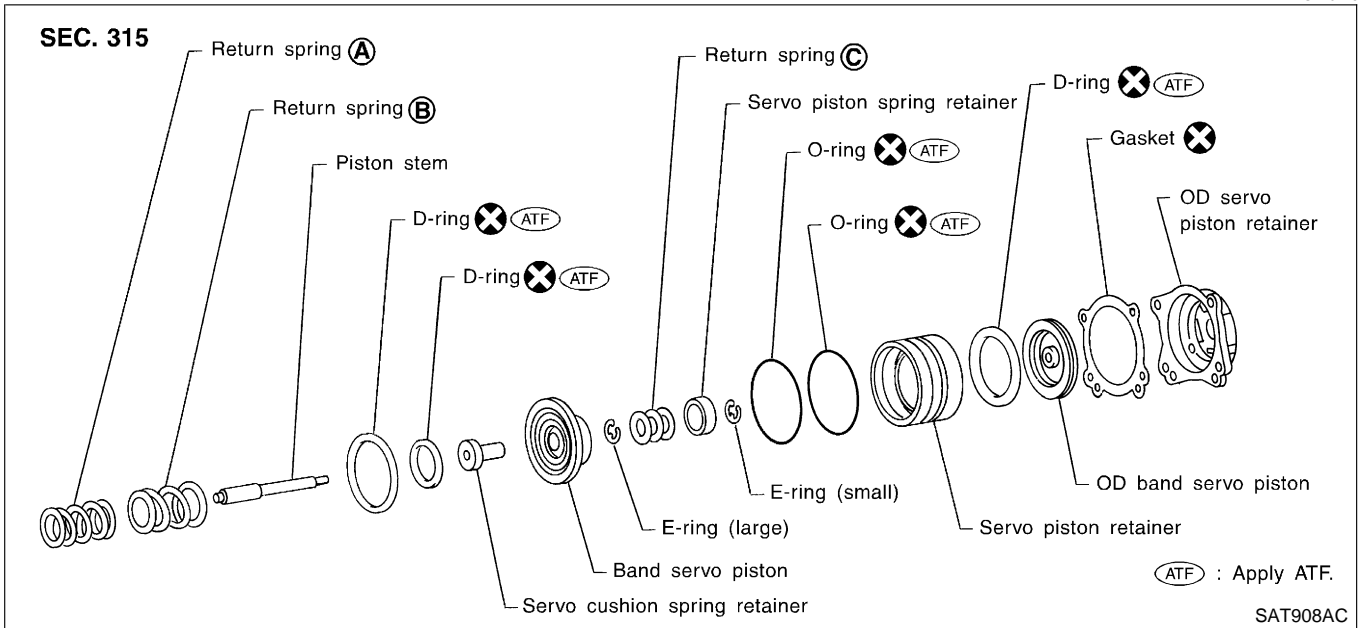

SAT908AC

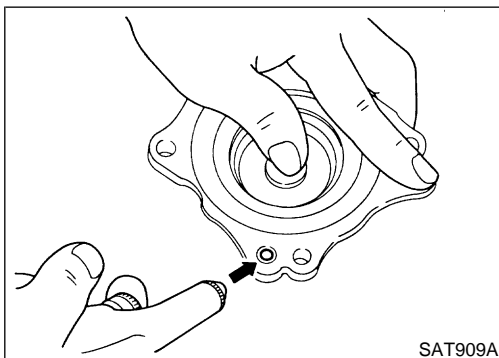

SAT909A

DISASSEMBLY

NGAT0149

- Block one oil hole in OD servo piston retainer and the center hole in OD band servo piston.
- Apply compressed air to the other oil hole in piston retainer to remove OD band servo piston from retainer.
- Remove D-ring from OD band servo piston.
- Remove band servo piston assembly from servo piston retainer by pushing it forward.

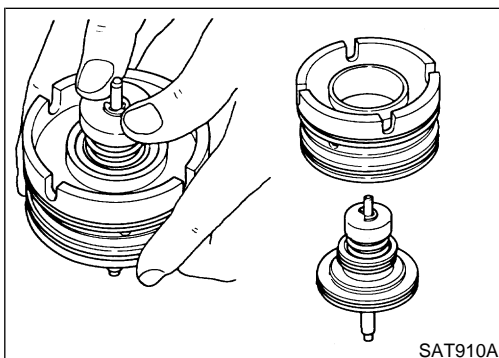

SAT910A

GI
MA
EM
LC
EC
FE
CL
MT
AT
TF
PD
AX
SU
BR
ST
RS
BT
HA
SC
EL
IDX

REPAIR FOR COMPONENT PARTS

Band Servo Piston Assembly (Cont'd)

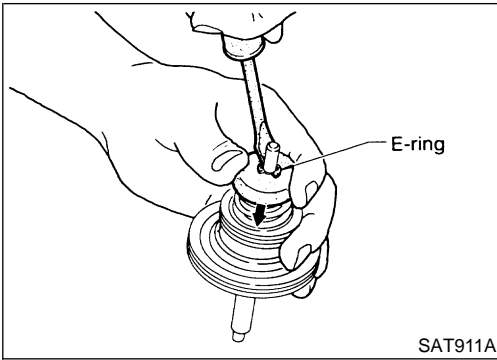

5. Place piston stem end on a wooden block. While pushing servo piston spring retainer down, remove E-ring.

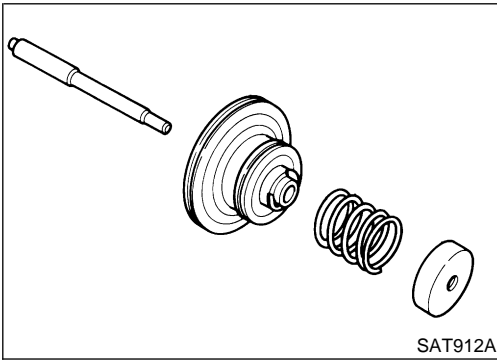

6. Remove servo piston spring retainer, return spring C and piston stem from band servo piston.

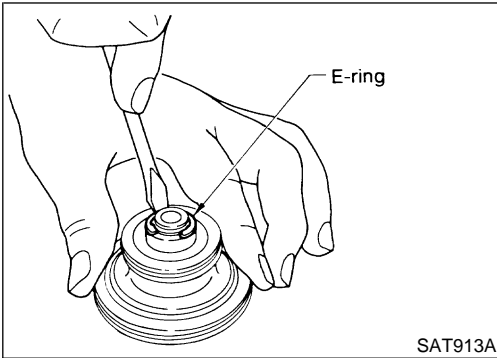

7. Remove E-ring from band servo piston.

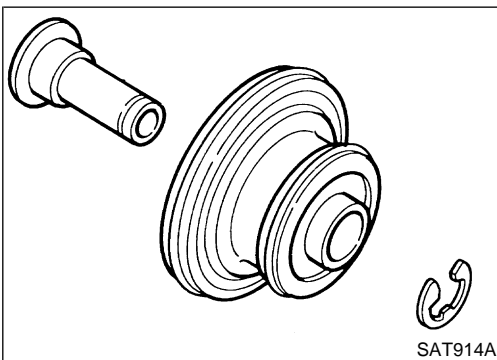

8. Remove servo cushion spring retainer from band servo piston.
9. Remove D-rings from band servo piston.
10. Remove O-rings from servo piston retainer.

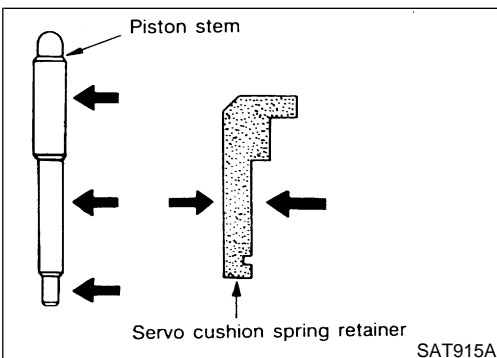

INSPECTION

Pistons, Retainers and Piston Stem

- Check frictional surfaces for abnormal wear or damage.

NGAT0150

NGAT0150S01

REPAIR FOR COMPONENT PARTS

Band Servo Piston Assembly (Cont'd)

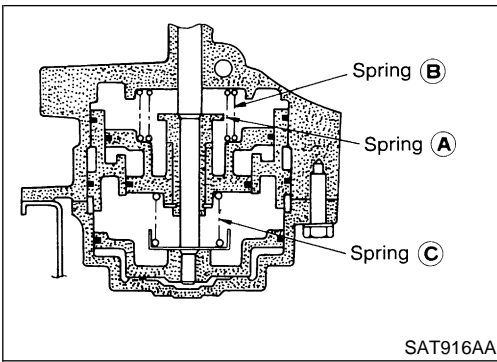

Return Springs

- Check for deformation or damage. Measure free length and outer diameter.

Inspection standard:

Refer to "Return Springs", AT-349.

NGAT0150S02

GI

MA

EM

LC

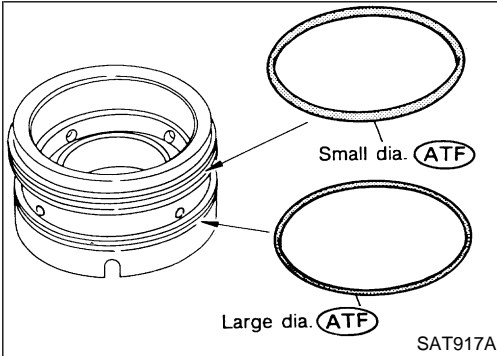

ASSEMBLY

1. Install O-rings onto servo piston retainer.
- **Apply ATF to O-rings.**
 - **Pay attention to position of each O-ring.**

NGAT0151

EC

FE

CL

MT

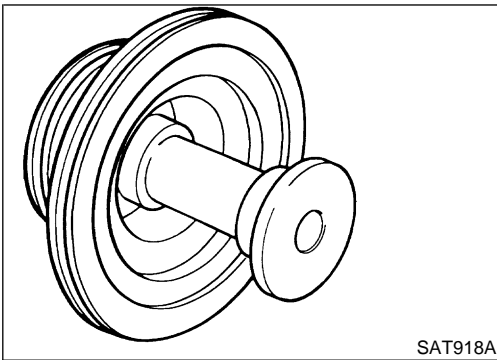

2. Install servo cushion spring retainer onto band servo piston.

AT

TF

PD

AX

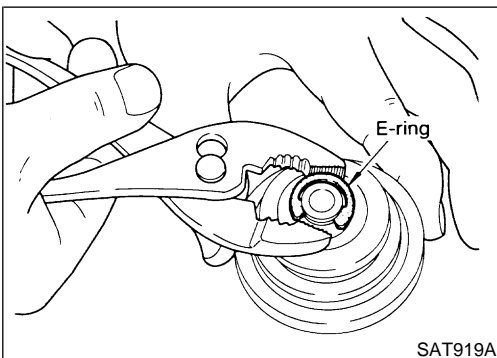

3. Install E-ring onto servo cushion spring retainer.

SU

BR

ST

RS

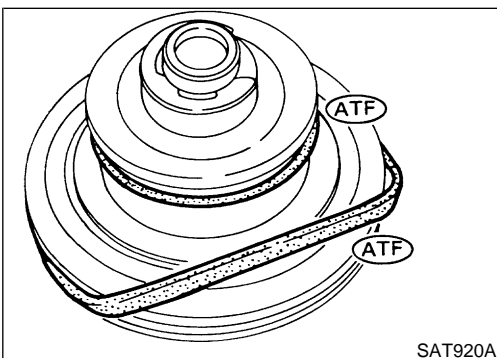

4. Install D-rings onto band servo piston.
- **Apply ATF to D-rings.**

BT

HA

SC

EL

IDX

REPAIR FOR COMPONENT PARTS

Band Servo Piston Assembly (Cont'd)

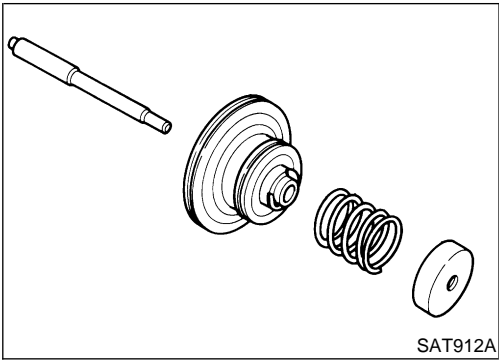

5. Install servo piston spring retainer, return spring C and piston stem onto band servo piston.

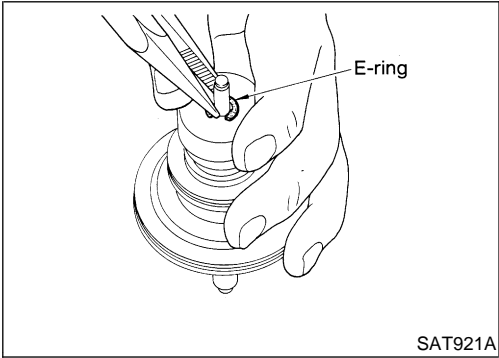

6. Place piston stem end on a wooden block. While pushing servo piston spring retainer down, install E-ring.

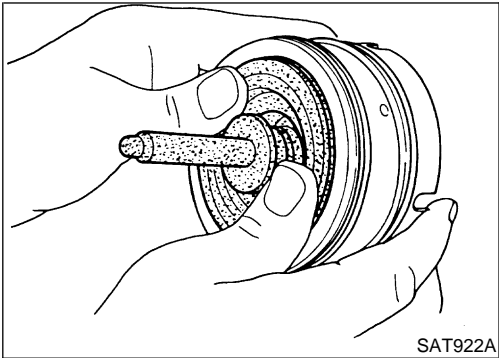

7. Install band servo piston assembly onto servo piston retainer by pushing it inward.

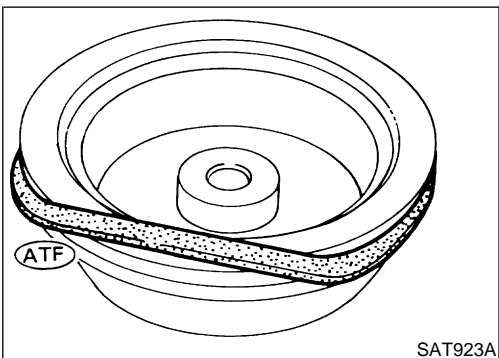

8. Install D-ring on OD band servo piston.
 - **Apply ATF to D-ring.**

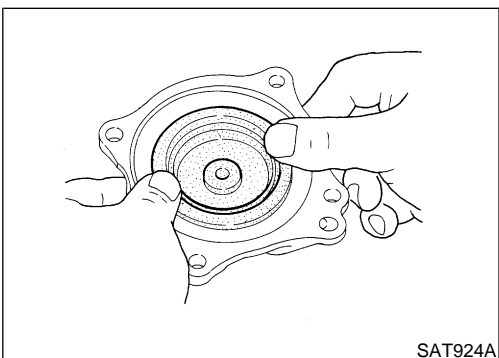

9. Install OD band servo piston onto servo piston retainer by pushing it inward.

Parking Pawl Components COMPONENTS

NGAT0152

GI
MA
EM
LC
EC
FE
CL
MT
AT
TF
PD
AX
SU
BR
ST
RS
BT
HA
SC
EL
IDX

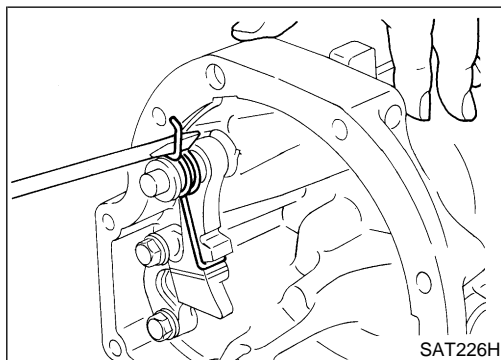
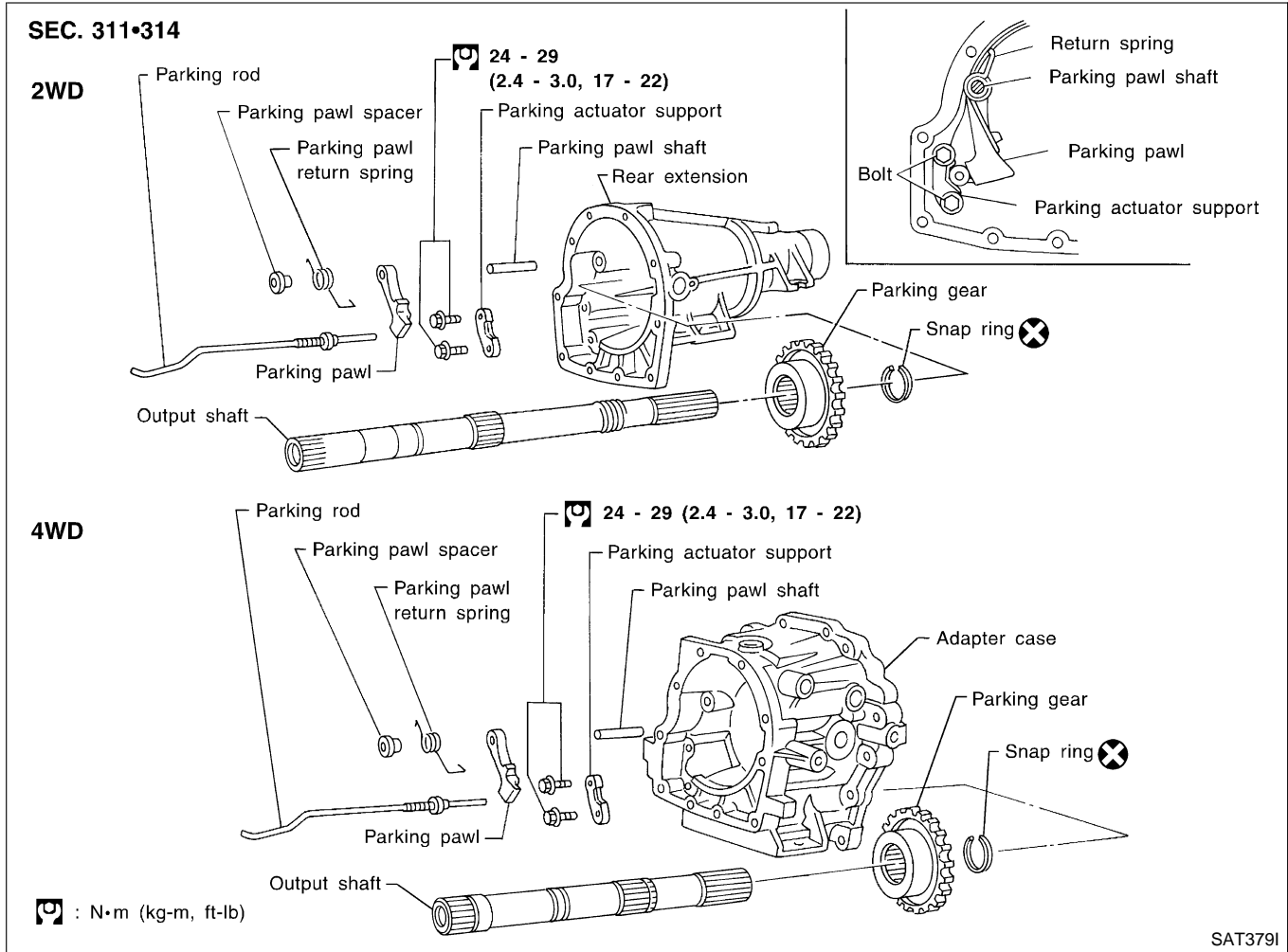

DISASSEMBLY

NGAT0153

1. Slide return spring to the front of adapter case or rear extension flange.
2. Remove return spring, pawl spacer and parking pawl from adapter case or rear extension.
3. Remove parking pawl shaft from adapter case or rear extension.
4. Remove parking actuator support from adapter case or rear extension.

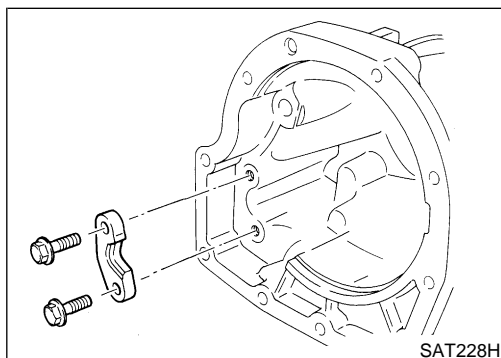

REPAIR FOR COMPONENT PARTS

Parking Pawl Components (Cont'd)

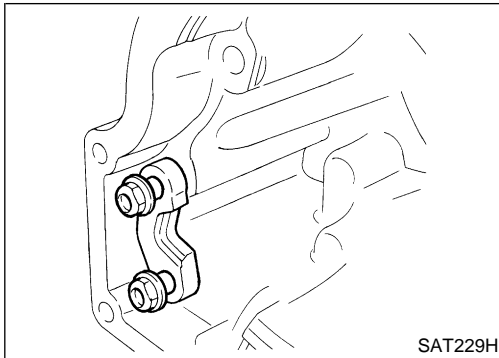

ASSEMBLY

NGAT0154

1. Install parking actuator support onto adapter case or rear extension.
2. Insert parking pawl shaft into adapter case or rear extension.
3. Install return spring, pawl spacer and parking pawl onto parking pawl shaft.

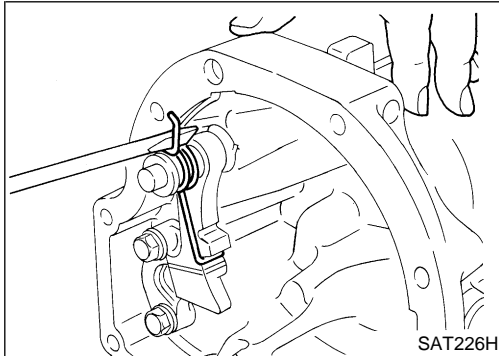

4. Bend return spring upward and install it onto adapter case or rear extension.

ASSEMBLY

Assembly (1)

NGAT0155

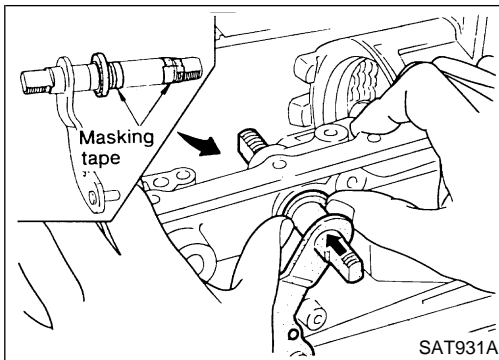

Assembly (1)

1. Install manual shaft components.
 - a. Install oil seal onto manual shaft.
 - **Apply ATF to oil seal.**
 - **Wrap threads of manual shaft with masking tape.**
 - b. Insert manual shaft and oil seal as a unit into transmission case.
 - c. Remove masking tape.

GI

MA

EM

LC

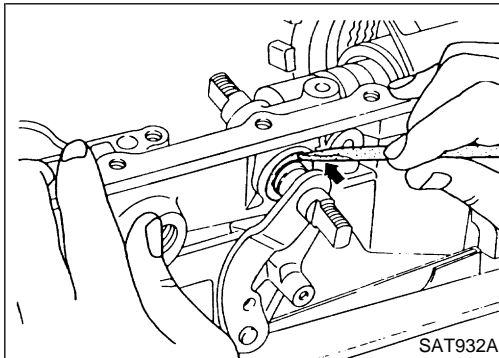

- d. Push oil seal evenly and install it onto transmission case.

EC

FE

CL

MT

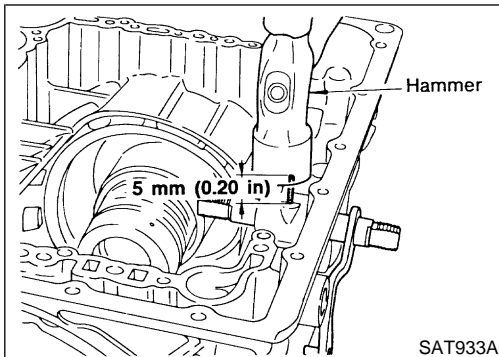

- e. Align groove in shaft with drive pin hole, then drive pin into position as shown in figure at left.

AT

TF

PD

AX

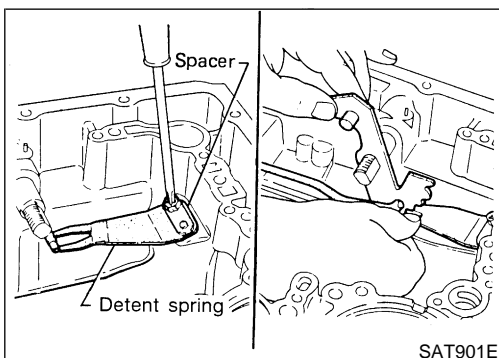

- f. Install detent spring and spacer.
- g. While pushing detent spring down, install manual plate onto manual shaft.

SU

BR

ST

RS

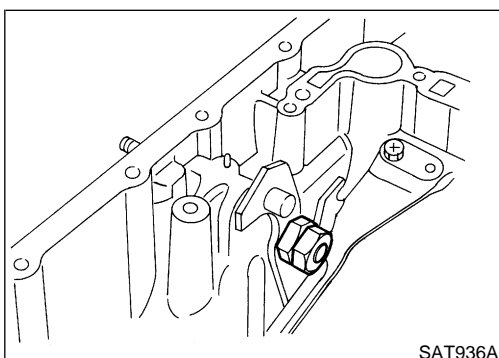

- h. Install lock nuts onto manual shaft.

BT

HA

SC

EL

IDX

ASSEMBLY

Assembly (1) (Cont'd)

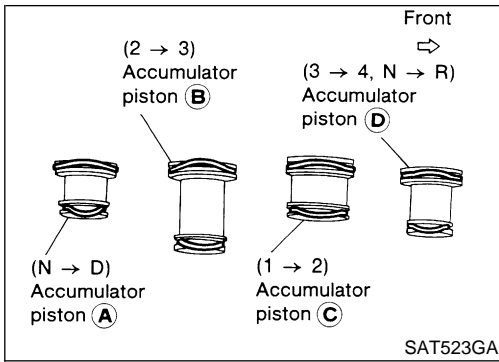

2. Install accumulator piston.
 - a. Install O-rings onto accumulator piston.
 - **Apply ATF to O-rings.**

Accumulator piston O-rings

Unit: mm (in)

Accumulator	A	B	C	D
Small diameter end	29 (1.14)	32 (1.26)	45 (1.77)	29 (1.14)
Large diameter end	45 (1.77)	50 (1.97)	50 (1.97)	45 (1.77)

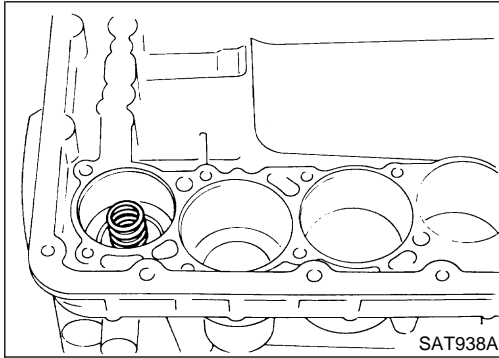

- b. Install return spring for accumulator A onto transmission case.

Free length of return spring:
Refer to "Return Springs", AT-349.

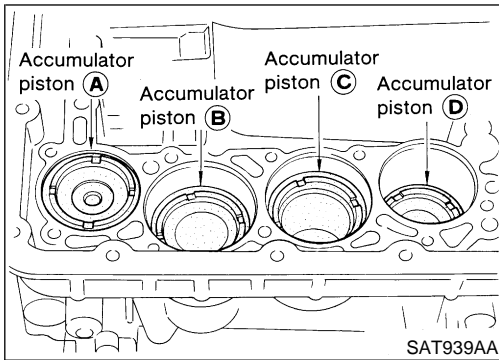

- c. Install accumulator pistons A, B, C and D.
 - **Apply ATF to transmission case.**

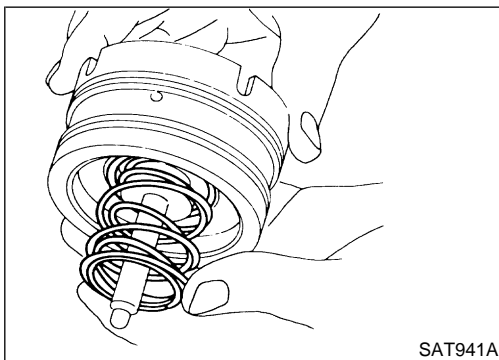

3. Install band servo piston.
 - a. Install return springs onto servo piston.

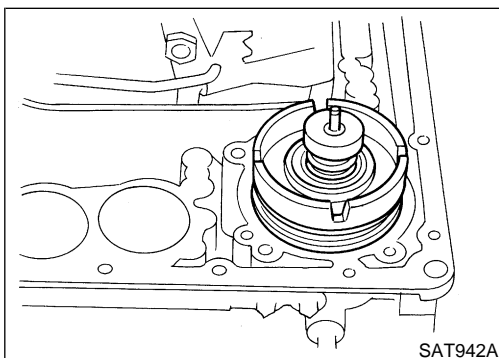

- b. Install band servo piston onto transmission case.
 - **Apply ATF to O-ring of band servo piston and transmission case.**
- c. Install gasket for band servo onto transmission case.

ASSEMBLY

Assembly (1) (Cont'd)

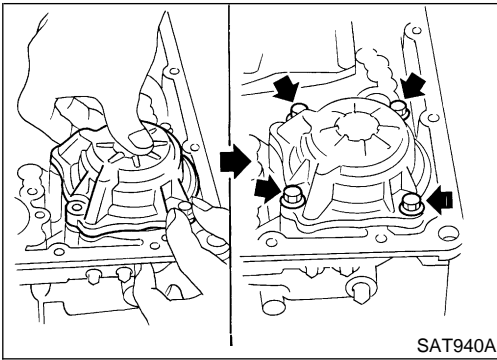

d. Install band servo retainer onto transmission case.

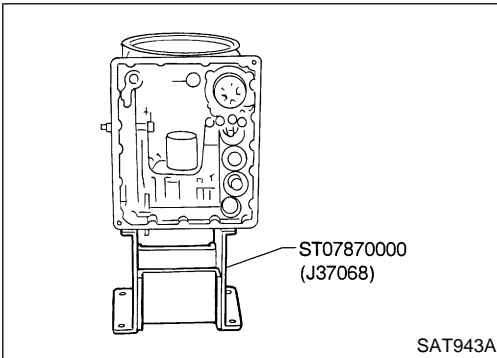

4. Install rear side clutch and gear components.
a. Place transmission case in vertical position.

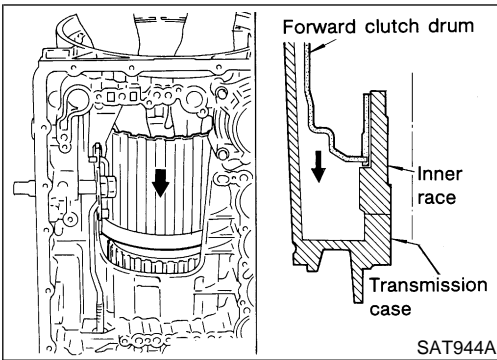

b. Slightly lift forward clutch drum assembly. Then slowly rotate it clockwise until its hub passes fully over clutch inner race inside transmission case.

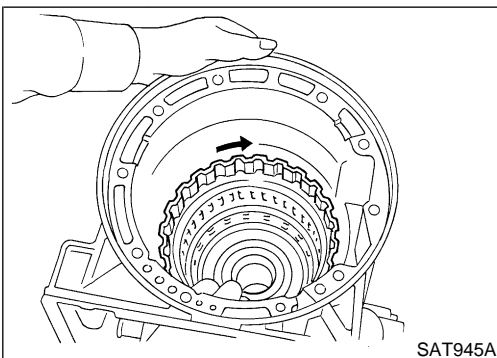

c. Check to be sure that rotation direction of forward clutch assembly is correct.

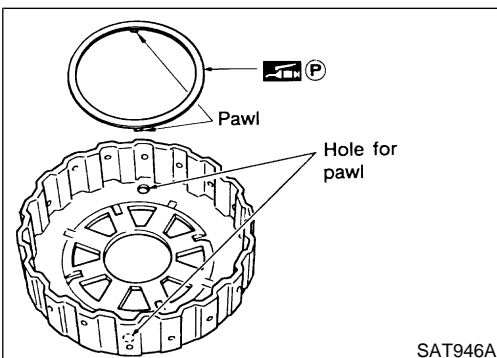

d. Install thrust washer onto front of overrun clutch hub.
 ● Apply petroleum jelly to the thrust washer.
 ● Insert pawls of thrust washer securely into holes in overrun clutch hub.

GI

MA

EM

LC

EC

FE

CL

MT

AT

TF

PD

AX

SU

BR

ST

RS

BT

HA

SC

EL

IDX

ASSEMBLY

Assembly (1) (Cont'd)

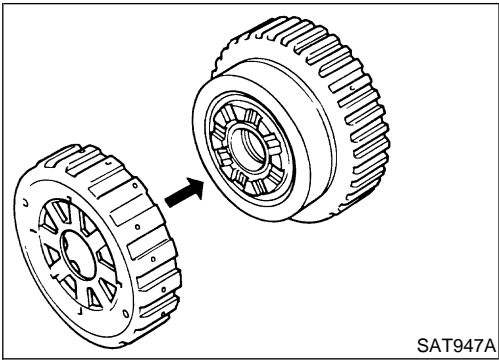

- e. Install overrun clutch hub onto rear internal gear assembly.

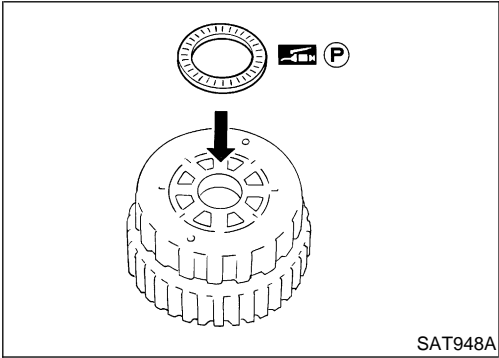

- f. Install needle bearing onto rear of overrun clutch hub.
● **Apply petroleum jelly to needle bearing.**

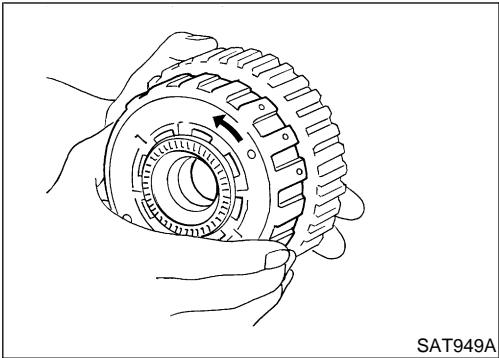

- g. Check that overrun clutch hub rotates as shown while holding forward clutch hub.

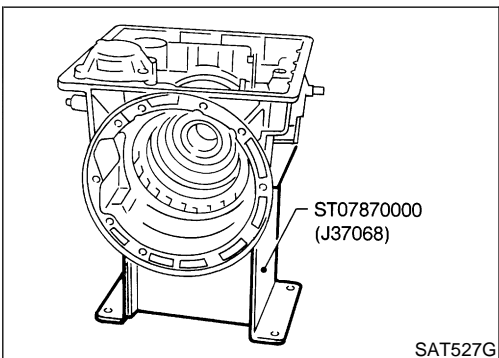

- h. Place transmission case into horizontal position.

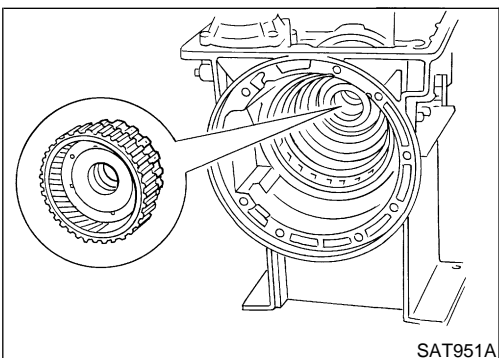

- i. Install rear internal gear, forward clutch hub and overrun clutch hub as a unit onto transmission case.

ASSEMBLY

Assembly (1) (Cont'd)

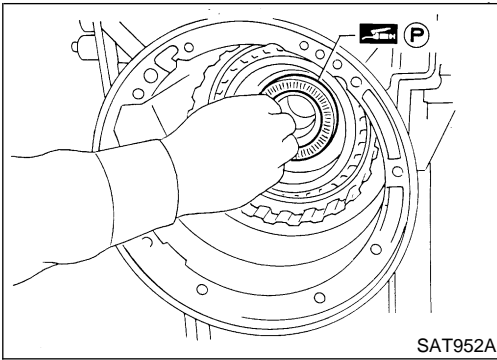

- j. Install needle bearing onto rear internal gear.
- **Apply petroleum jelly to needle bearing.**

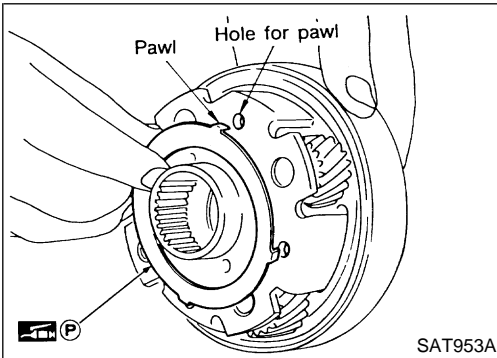

- k. Install bearing race onto rear of front internal gear.
- **Apply petroleum jelly to bearing race.**
 - **Securely engage pawls of bearing race with holes in front internal gear.**

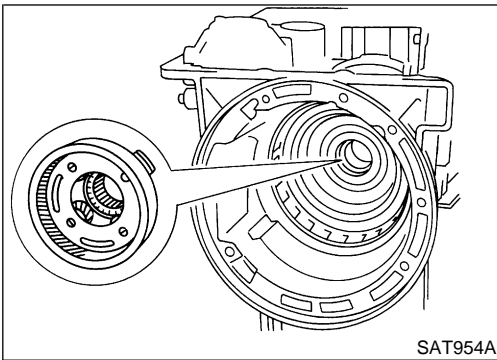

- l. Install front internal gear on transmission case.

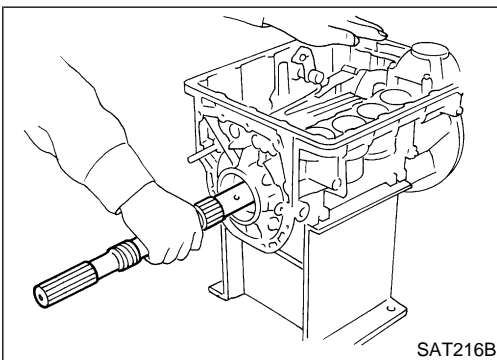

5. Install output shaft and parking gear.
- a. Insert output shaft from rear of transmission case while slightly lifting front internal gear.
- **Do not force output shaft against front of transmission case.**

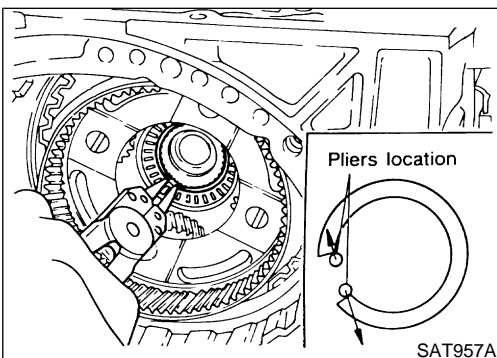

- b. Carefully push output shaft against front of transmission case. Install snap ring on front of output shaft.
- **Check to be sure output shaft cannot be removed in rear direction.**

GI

MA

EM

LC

EC

FE

CL

MT

AT

TF

PD

AX

SU

BR

ST

RS

BT

HA

SC

EL

IDX

ASSEMBLY

Assembly (1) (Cont'd)

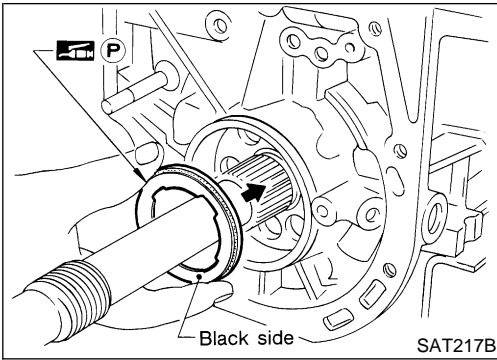

- c. Install needle bearing on transmission case.
 - Pay attention to its direction — **Black side goes to rear.**
 - Apply petroleum jelly to needle bearing.

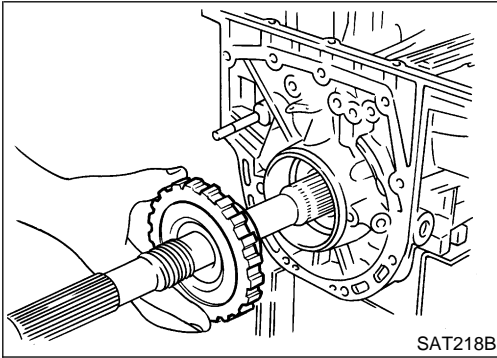

- d. Install parking gear on transmission case.

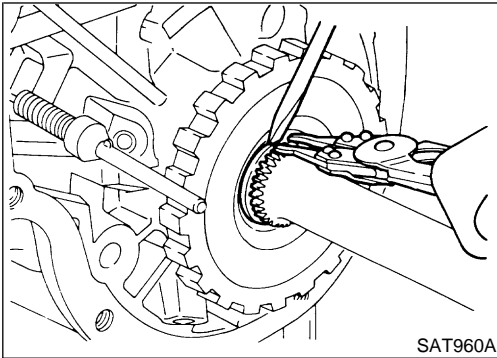

- e. Install snap ring on rear of output shaft.
 - Check to be sure output shaft cannot be removed in forward direction.

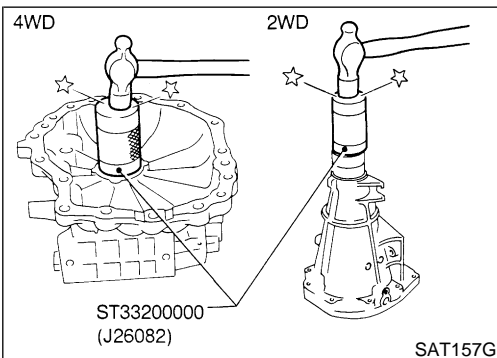

6. Install adapter case or rear extension.
 - a. Install oil seal on adapter case or rear extension.
 - Apply ATF to oil seal.

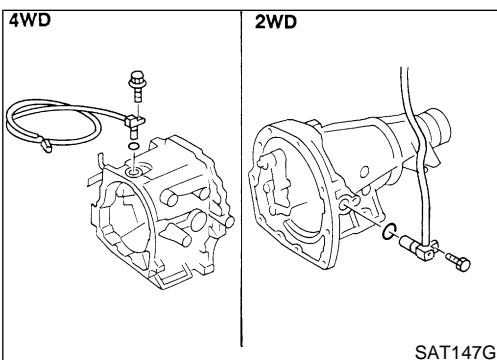

- b. Install O-ring on revolution sensor.
 - Apply ATF to O-ring.
 - c. Install revolution sensor on adapter case or rear extension.

ASSEMBLY

Assembly (1) (Cont'd)

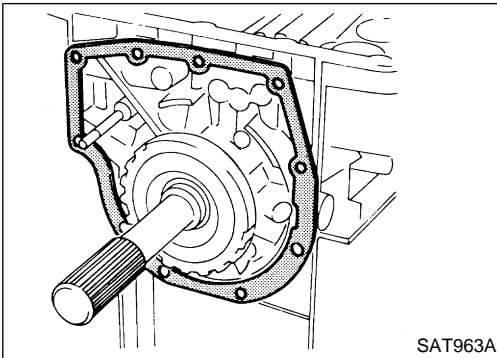

- d. Install rear extension gasket on transmission case.

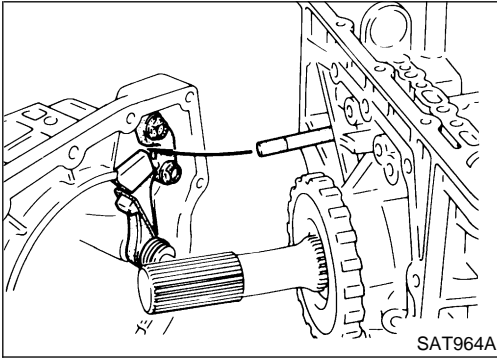

- e. Install parking rod on transmission case.

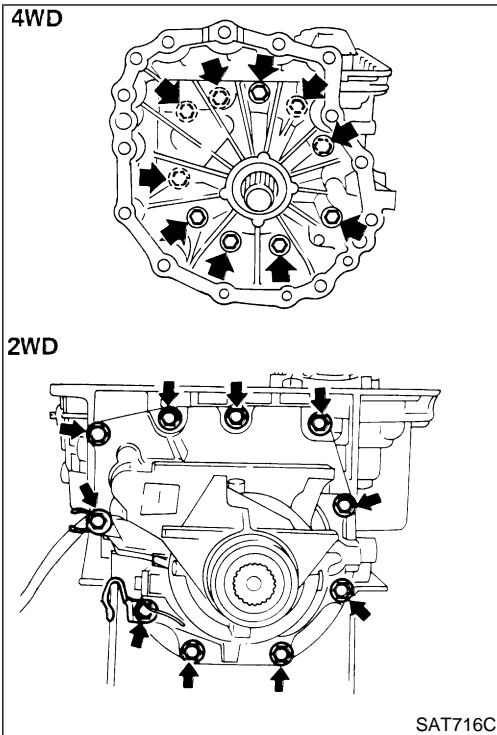

- f. Install rear extension or adapter case on transmission case.

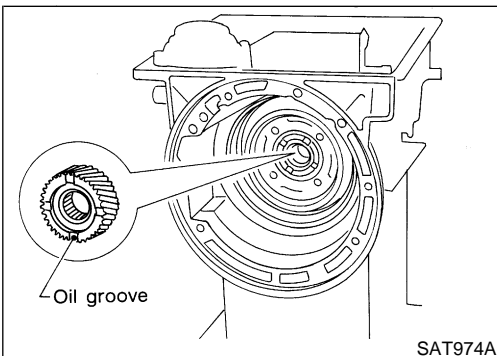

7. Install front side clutch and gear components.
a. Install rear sun gear on transmission case.
● Pay attention to its direction.

GI

MA

EM

LC

EC

FE

CL

MT

AT

TF

PD

AX

SU

BR

ST

RS

BT

HA

SC

EL

IDX

ASSEMBLY

Assembly (1) (Cont'd)

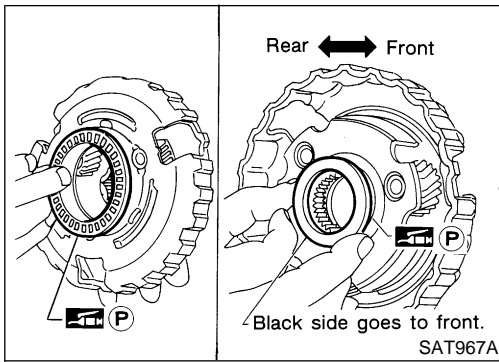

- b. Make sure needle bearing is on front of front planetary carrier.
 - **Apply petroleum jelly to needle bearing.**
- c. Make sure needle bearing is on rear of front planetary carrier.
 - **Apply petroleum jelly to bearing.**
 - **Pay attention to its direction — Black side goes to front.**

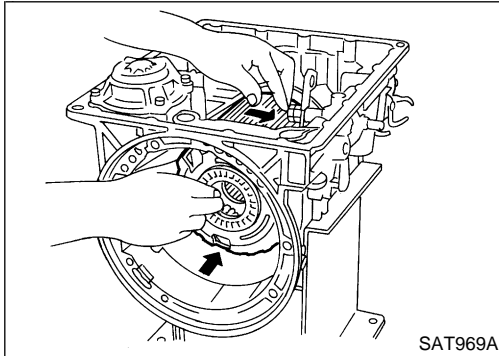

- d. While rotating forward clutch drum clockwise, install front planetary carrier on forward clutch drum.

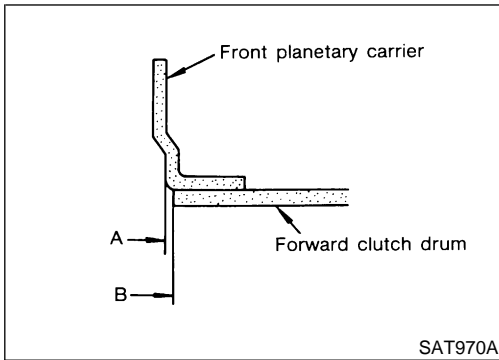

- **Check that portion A of front planetary carrier protrudes approximately 2 mm (0.08 in) beyond portion B of forward clutch assembly.**

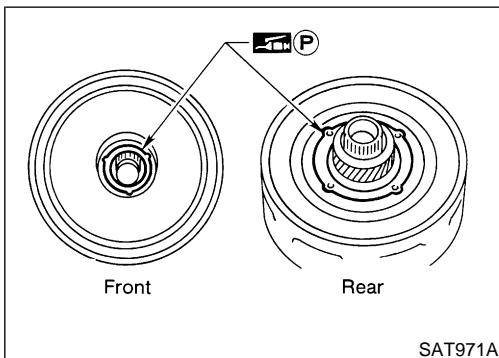

- e. Make sure bearing races are on front and rear of clutch pack.
 - **Apply petroleum jelly to bearing races.**
 - **Securely engage pawls of bearing races with holes in clutch pack.**

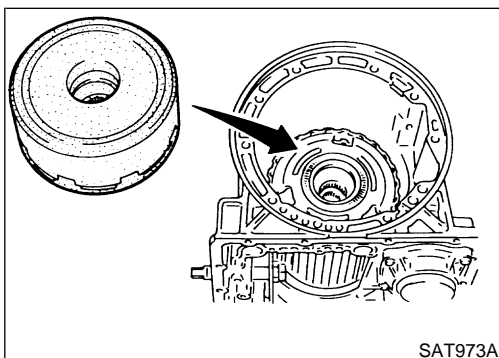

- f. Install clutch pack into transmission case.

Adjustment

NGAT0156

When any parts listed in the following table are replaced, total end play or reverse clutch end play must be adjusted.

Part name	Total end play	Reverse clutch end play
Transmission case	•	•
Low one-way clutch inner race	•	•
Overrun clutch hub	•	•
Rear internal gear	•	•
Rear planetary carrier	•	•
Rear sun gear	•	•
Front planetary carrier	•	•
Front sun gear	•	•
High clutch hub	•	•
High clutch drum	•	•
Oil pump cover	•	•
Reverse clutch drum	—	•

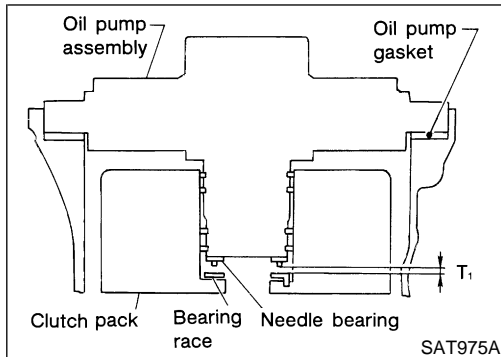

1. Adjust total end play.

Total end play "T₁":

0.25 - 0.55 mm (0.0098 - 0.0217 in)

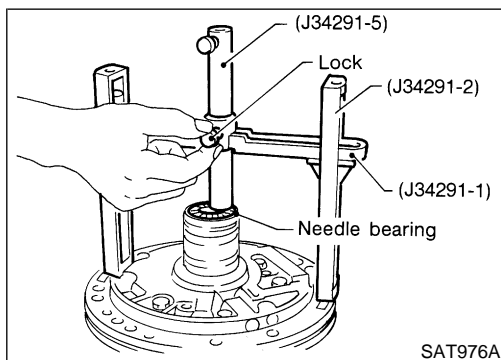

- a. With needle bearing installed, place J34291-1 (bridge), J34291-2 (legs) and the J34291-5 (gauging cylinder) onto oil pump. The long ends of legs should be placed firmly on machined surface of oil pump assembly. The gauging cylinder should rest on top of the needle bearing. Lock gauging cylinder in place with set screw.

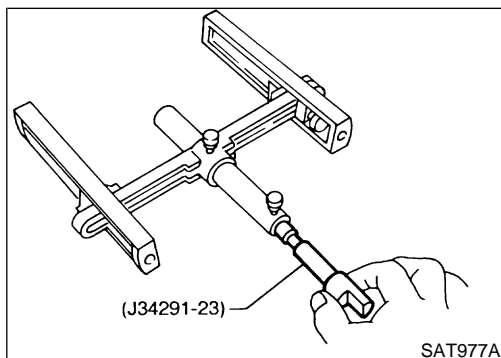

- b. Install J34291-23 (gauging plunger) into gauging cylinder.

GI

MA

EM

LC

EC

FE

CL

MT

AT

TF

PD

AX

SU

BR

ST

RS

BT

HA

SC

EL

IDX

ASSEMBLY

Adjustment (Cont'd)

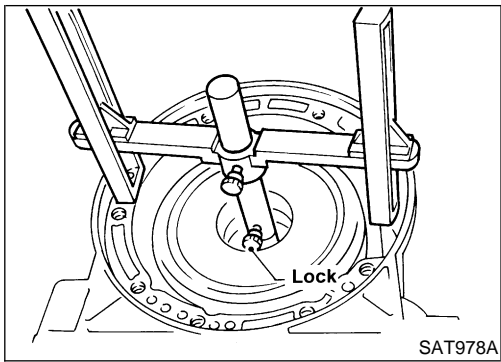

- c. Install original bearing race inside reverse clutch drum. Place shim selecting gauge with its legs on machined surface of transmission case (no gasket). Allow gauging plunger to rest on bearing race. Lock gauging plunger in place with set screw.

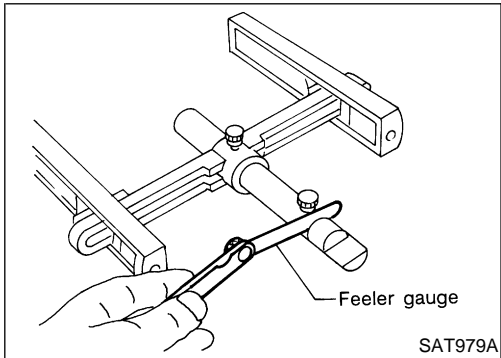

- d. Remove Tool and use feeler gauge to measure gap between gauging cylinder and gauging plunger. This measurement should give exact total end play.

Total end play "T₁":
0.25 - 0.55 mm (0.0098 - 0.0217 in)

- If end play is out of specification, decrease or increase thickness of oil pump cover bearing race as necessary.

Available oil pump cover bearing race:
Refer to "Total End Play", AT-353.

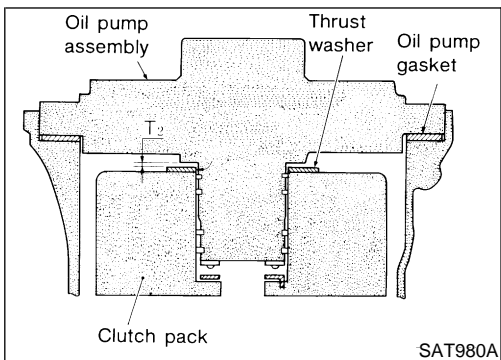

2. Adjust reverse clutch drum end play.
Reverse clutch drum end play "T₂":
0.55 - 0.90 mm (0.0217 - 0.0354 in)

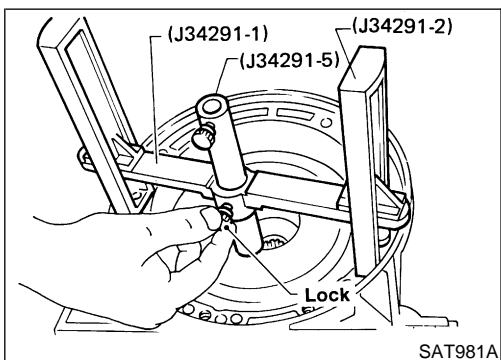

- a. Place J34291-1 (bridge), J34291-2 (legs) and J34291-5 (gauging cylinder) on machined surface of transmission case (no gasket). Allow gauging cylinder to rest on front thrust surface of reverse clutch drum. Lock cylinder in place with set screw.

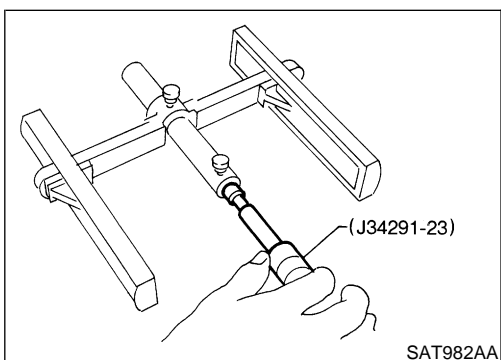

- b. Install J34291-23 (gauging plunger) into gauging cylinder.

ASSEMBLY

Adjustment (Cont'd)

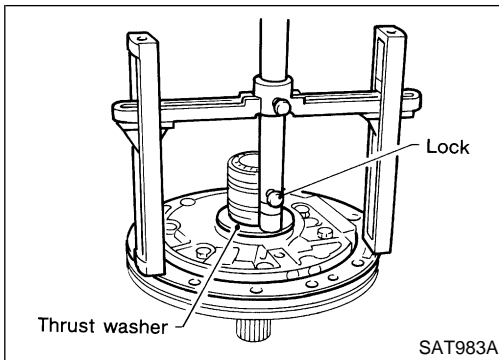

- c. Install original thrust washer on oil pump. Place shim setting gauge legs onto machined surface of oil pump assembly. Allow gauging plunger to rest on thrust washer. Lock plunger in place with set screw.

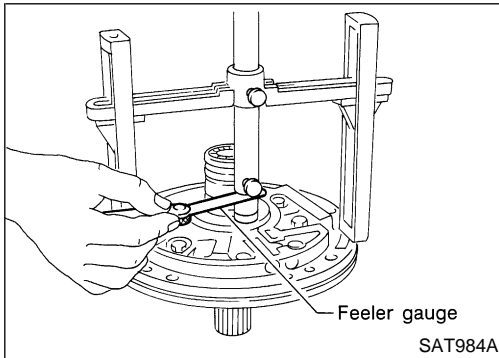

- d. Use feeler gauge to measure gap between gauging plunger and gauging cylinder. This measurement should give you exact reverse clutch drum end play.

**Reverse clutch drum end play "T₂":
0.55 - 0.90 mm (0.0217 - 0.0354 in)**

- If end play is out of specification, decrease or increase thickness of oil pump thrust washer as necessary.

Available oil pump thrust washer:

Refer to "Reverse Clutch Drum End Play", AT-353.

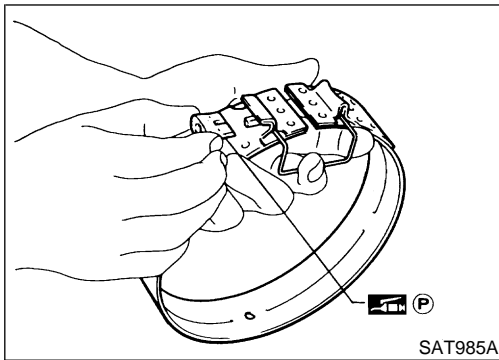

Assembly (2)

1. Install brake band and band strut.
 - a. Install band strut on brake band.
 - **Apply petroleum jelly to band strut.**

NGAT0157

AT

TF

PD

AX

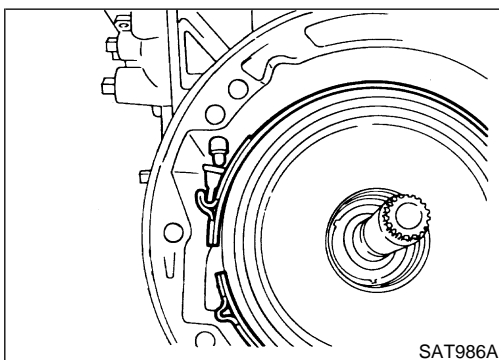

- b. Place brake band on periphery of reverse clutch drum, and insert band strut into end of band servo piston stem.

SU

BR

ST

RS

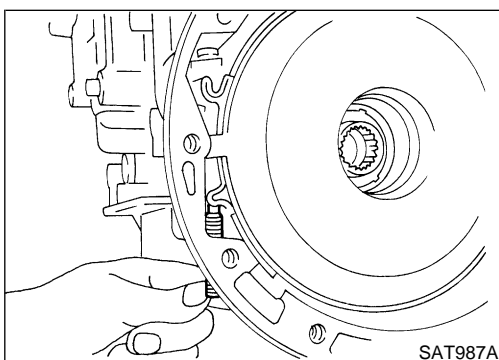

- c. Install anchor end pin on transmission case. Then, tighten anchor end pin just enough so that reverse clutch drum (clutch pack) will not tilt forward.

BT

HA

SC

EL

IDX

ASSEMBLY

Assembly (2) (Cont'd)

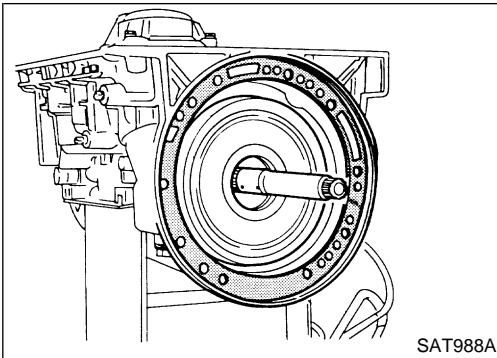

2. Install input shaft on transmission case.
 - **Pay attention to its direction — O-ring groove side is front.**
3. Install gasket on transmission case.

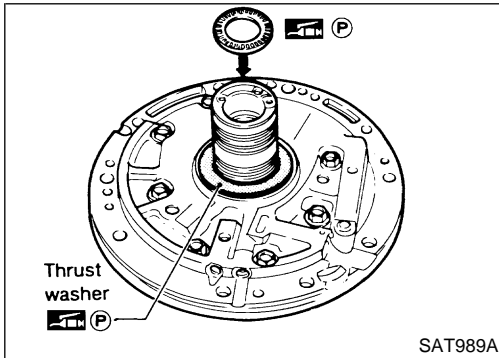

4. Install oil pump assembly.
 - a. Install needle bearing on oil pump assembly.
 - **Apply petroleum jelly to the needle bearing.**
 - b. Install selected thrust washer on oil pump assembly.
 - **Apply petroleum jelly to thrust washer.**

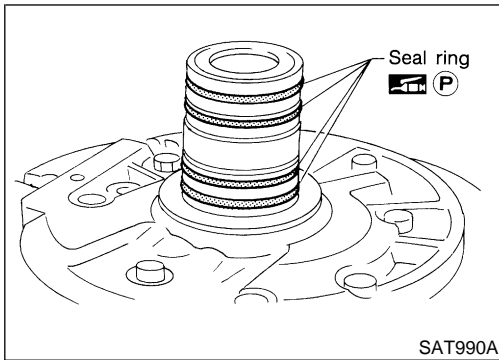

- c. Carefully install seal rings into grooves and press them into the petroleum jelly so that they are a tight fit.

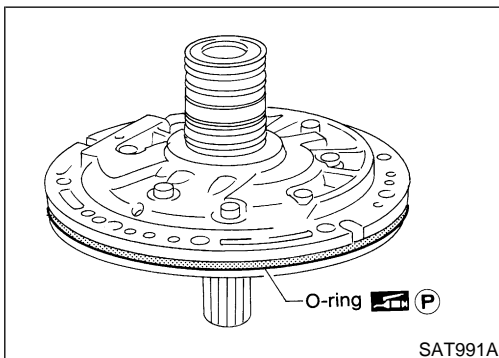

- d. Install O-ring on oil pump assembly.
 - **Apply petroleum jelly to O-ring.**

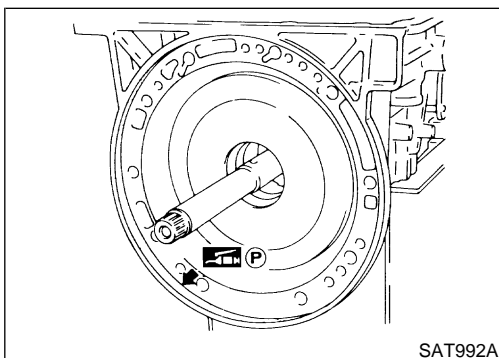

- e. Apply petroleum jelly to mating surface of transmission case and oil pump assembly.

ASSEMBLY

Assembly (2) (Cont'd)

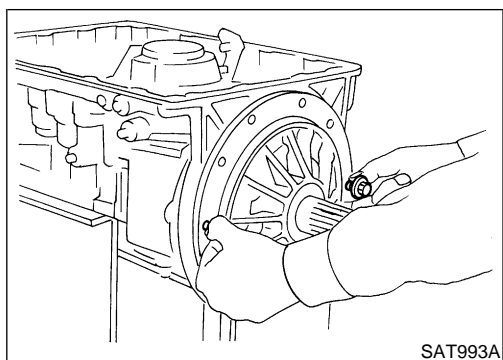

- f. Install oil pump assembly.
- Install two converter housing securing bolts in bolt holes in oil pump assembly as guides.

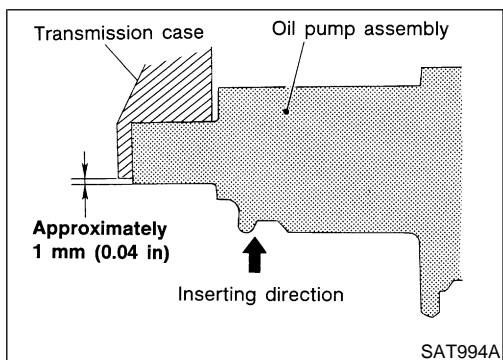

- Insert oil pump assembly to the specified position in transmission, as shown at left.

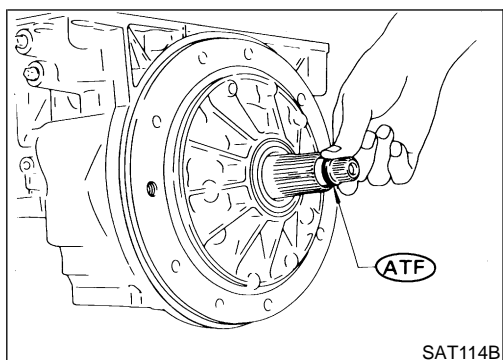

5. Install O-ring on input shaft.
- Apply ATF to O-rings.

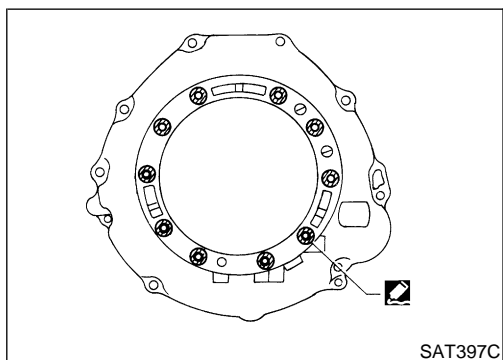

6. Install converter housing.
- a. Apply sealant to outer periphery of bolt holes in converter housing.
- Use Genuine Anaerobic Liquid Gasket or equivalent. Refer to **GI-50**, "RECOMMENDED CHEMICAL PRODUCTS AND SEALANTS".
 - Do not apply too much sealant.

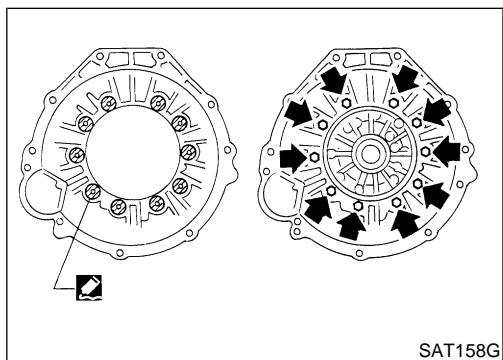

- b. Apply sealant to seating surfaces of bolts that secure front cover of converter housing.
- Use Genuine Anaerobic Liquid Gasket or equivalent. Refer to **GI-50**, "RECOMMENDED CHEMICAL PRODUCTS AND SEALANTS".
- c. Install converter housing on transmission case.
7. Install turbine revolution sensor (VG33ER only).

GI

MA

EM

LC

EC

FE

CL

MT

AT

TF

PD

AX

SU

BR

ST

RS

BT

HA

SC

EL

IDX

ASSEMBLY

Assembly (2) (Cont'd)

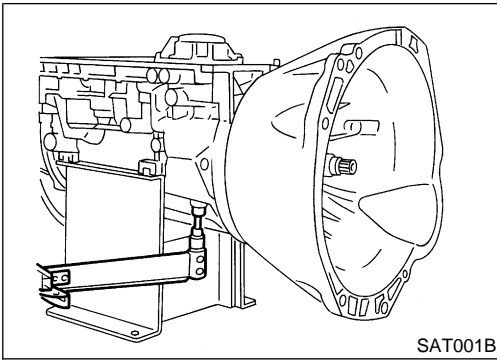

8. Adjust brake band.
 - a. Tighten anchor end bolt to specified torque.
Anchor end bolt:
 : 4 - 6 N·m (0.4 - 0.6 kg-m, 35 - 52 in-lb)
 - b. Back off anchor end bolt two and a half turns.

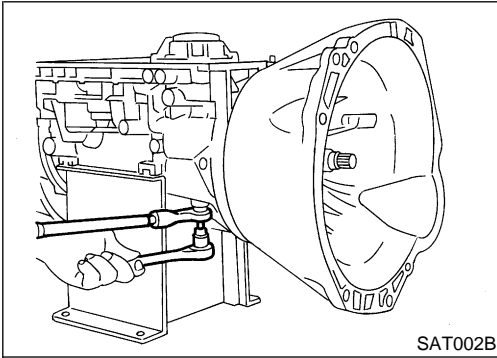

- c. While holding anchor end pin, tighten lock nut.

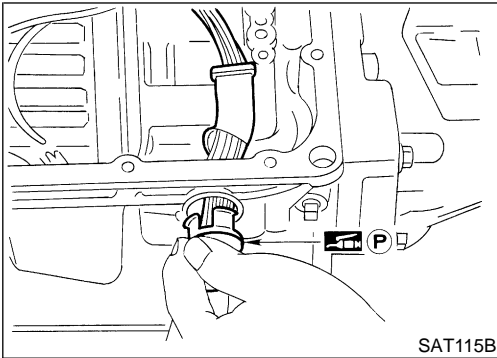

9. Install terminal cord assembly.
 - a. Install O-ring on terminal cord assembly.
 - **Apply petroleum jelly to O-ring.**
 - b. Compress terminal cord assembly stopper and install terminal cord assembly on transmission case.

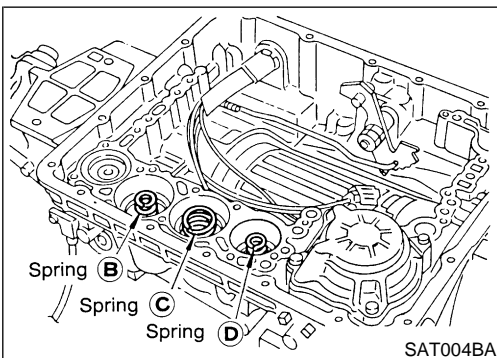

10. Install control valve assembly.
 - a. Install accumulator piston return springs B, C and D.
Free length of return springs:
Refer to "Return Springs", AT-349.

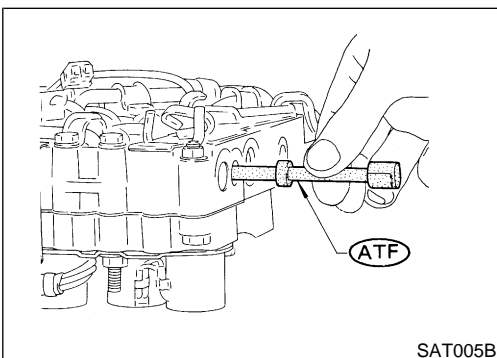

- b. Install manual valve on control valve.
 - **Apply ATF to manual valve.**

ASSEMBLY

Assembly (2) (Cont'd)

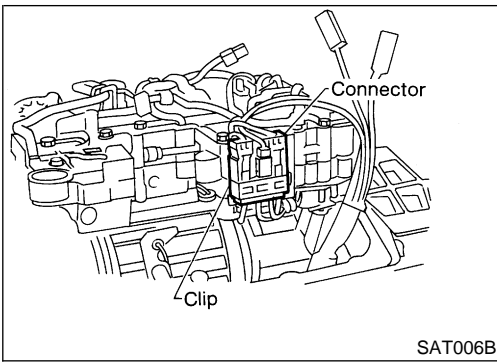

- c. Place control valve assembly on transmission case. Connect solenoid connector for upper body.
- d. Install connector clip.

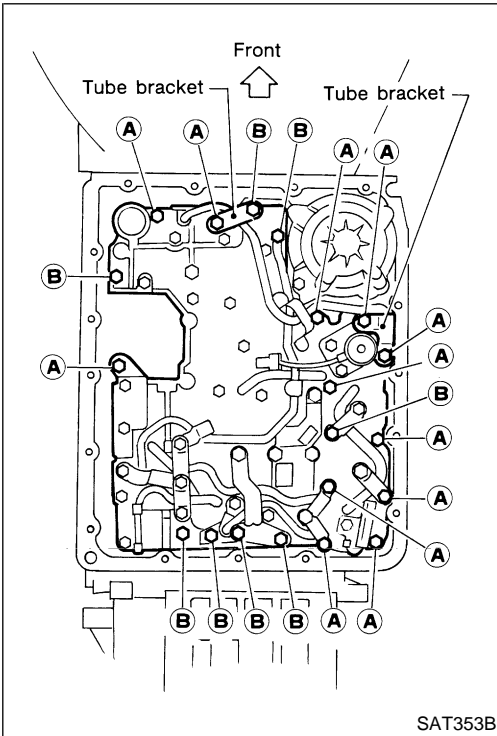

- e. Install control valve assembly on transmission case.
- f. Install connector tube brackets and tighten bolts A and B.

● **Check that terminal assembly does not catch.**

Bolt symbol	ℓ mm (in)
A	33 (1.30)
B	45 (1.77)

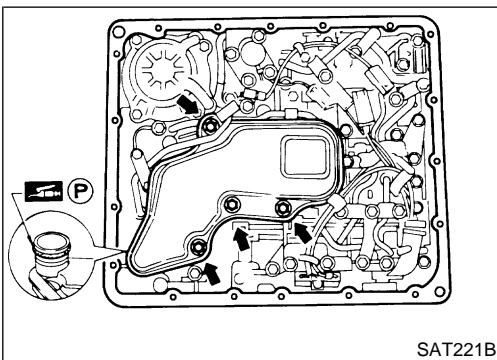

- g. Install O-ring on oil strainer.
- **Apply petroleum jelly to O-ring.**
- h. Install oil strainer on control valve.

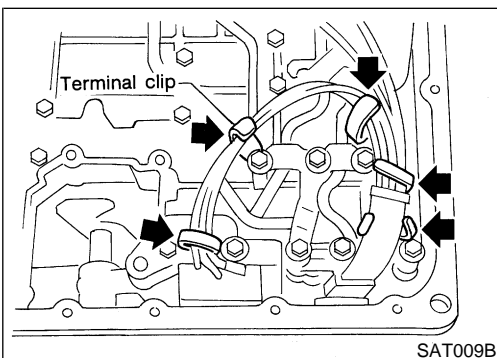

- i. Securely fasten terminal harness with clips.

GI
MA
EM
LC
EC
FE
CL
MT
AT
TF
PD
AX
SU
BR
ST
RS
BT
HA
SC
EL
IDX

ASSEMBLY

Assembly (2) (Cont'd)

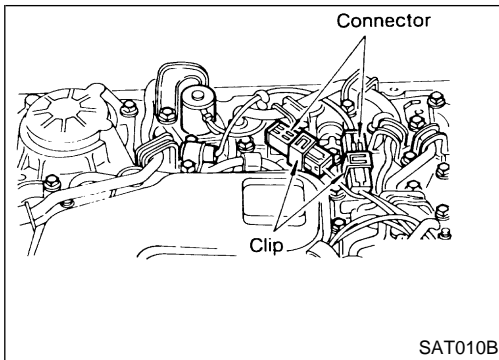

- j. Install torque converter clutch solenoid valve and fluid temperature sensor connectors.

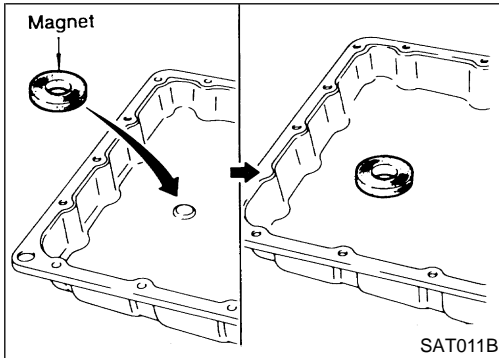

11. Install oil pan.
a. Attach a magnet to oil pan.

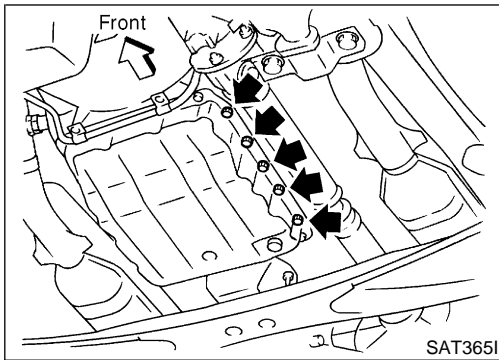

- b. Install new oil pan gasket on transmission case.
c. Install oil pan and bracket on transmission case.
● **Always replace oil pan bolts as they are self-sealing bolts.**
● **Before installing bolts, remove traces of sealant and oil from mating surface and thread holes.**
● **Tighten four bolts in a criss-cross pattern to prevent dislocation of gasket.**
d. Tighten drain plug.

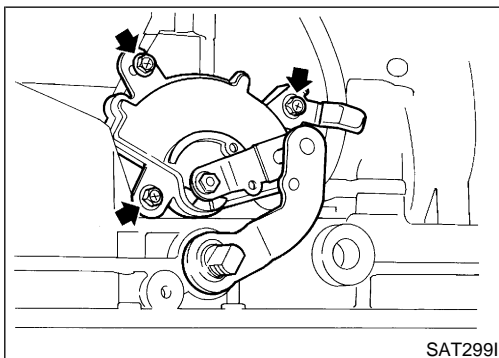

12. Install park/neutral position (PNP) switch.
a. Check that manual shaft is in 1 position.
b. Temporarily install park/neutral position (PNP) switch on manual shaft.
c. Move manual shaft to N.

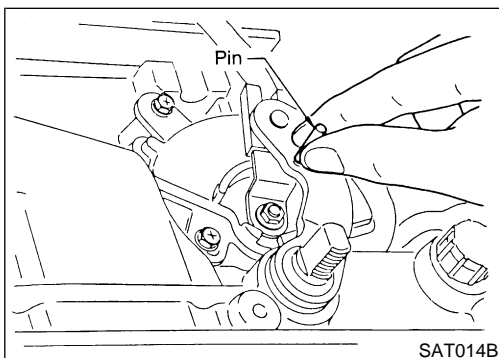

- d. Tighten bolts while inserting 4.0 mm (0.157 in) dia. pin vertically into locating holes in park/neutral position (PNP) switch and manual shaft.

ASSEMBLY

Assembly (2) (Cont'd)

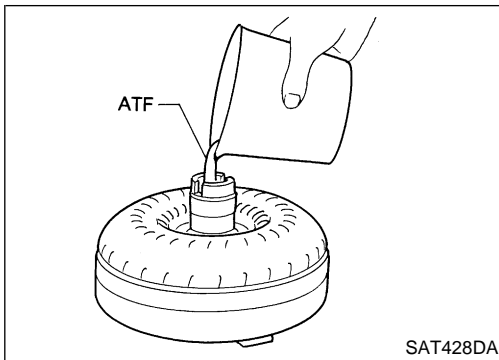

13. Install torque converter.

a. Pour ATF into torque converter.

- **Approximately 2 liters (2-1/8 US qt, 1-3/4 Imp qt) of fluid are required for a new torque converter.**
- **When reusing old torque converter, add the same amount of fluid as was drained.**

GI
MA
EM

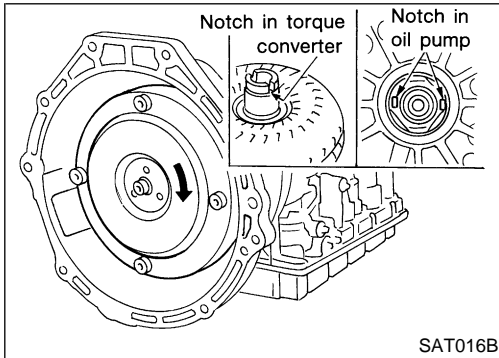

b. Install torque converter while aligning notches and oil pump.

LC
EC
FE

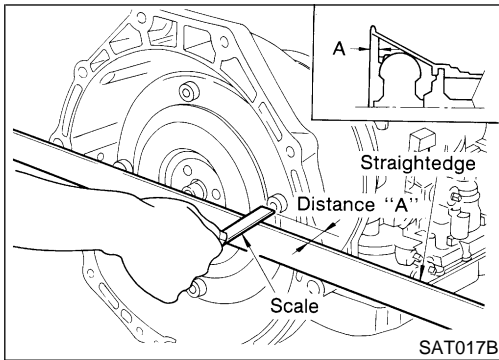

c. Measure distance A to check that torque converter is in proper position.

Distance "A":

VG33E only: 26.0 mm (1.024 in) or more

VG33ER only: 25.0 mm (0.984 in) or more

CL
MT

AT

TF

PD

AX

SU

BR

ST

RS

BT

HA

SC

EL

IDX

SERVICE DATA AND SPECIFICATIONS (SDS)

General Specifications

General Specifications

NGAT0160

Applied model	VG33E engine		VG33ER engine	
	2WD	4WD	2WD	4WD
Automatic transmission model	RE4R01A			
Transmission model code number	43X64	4EX01, 4FX06	4EX67	4EX68, 4FX07
Stall torque ratio	2.0 : 1			
Transmission gear ratio	1st	2.785		
	2nd	1.545		
	Top	1.000		
	O/D	0.694		
	Reverse	2.272		
Recommended fluid	Nissan Matic "D" (Continental U.S. and Alaska) or Genuine Nissan Automatic Transmission Fluid (Canada)*1			
Fluid capacity	8.3ℓ (8-3/4 US qt, 7-1/4 Imp qt)	8.5ℓ (9 US qt, 7-1/2 Imp qt)	8.3ℓ (8-3/4 US qt, 7-1/4 Imp qt)	8.5ℓ (9 US qt, 7-1/2 Imp qt)

*1: Refer to **MA-13**, "Fluids and Lubricants".

Shift Schedule

VEHICLE SPEED WHEN SHIFTING GEARS THROTTLE POSITION

NGAT0178

NGAT0178S01

Throttle position		Vehicle speed km/h (MPH)						
		D ₁ →D ₂	D ₂ →D ₃	D ₃ →D ₄	D ₄ →D ₃	D ₃ →D ₂	D ₂ →D ₁	1 ₂ →1 ₁
Full throttle	VG33E only	47 - 51 (29 - 32)	92 - 100 (57 - 62)	146 - 156 (91 - 97)	141 - 151 (88 - 94)	87 - 95 (54 - 59)	42 - 46 (26 - 29)	43 - 47 (27 - 29)
	VG33ER only	49 - 53 (30 - 33)	94 - 102 (58 - 63)	151 - 161 (94 - 100)	147 - 157 (91 - 98)	87 - 95 (54 - 59)	43 - 47 (27 - 29)	54 - 58 (34 - 36)
Half throttle	VG33E only	34 - 38 (21 - 24)	68 - 74 (42 - 46)	132 - 140 (82 - 87)	59 - 67 (37 - 42)	31 - 37 (19 - 23)	10 - 14 (6 - 9)	43 - 47 (27 - 29)
	VG33ER only	41 - 45 (25 - 28)	68 - 74 (42 - 46)	121 - 129 (75 - 80)	76 - 84 (47 - 52)	41 - 47 (25 - 29)	11 - 15 (7 - 9)	54 - 58 (34 - 36)

VEHICLE SPEED WHEN PERFORMING AND RELEASING LOCK-UP

NGAT0178S02

Throttle position		Overdrive control switch [Shift position]	Vehicle speed km/h (MPH)	
			Lock-up "ON"	Lock-up "OFF"
Full throttle	VG33E only	ON [D ₄]	147 - 155 (91 - 96)	142 - 150 (88 - 93)
		OFF [D ₃]	74 - 82 (46 - 51)	71 - 79 (44 - 49)
	VG33ER only	ON [D ₄]	152 - 160 (94 - 99)	148 - 156 (92 - 97)
		OFF [D ₃]	86 - 94 (53 - 58)	83 - 91 (52 - 57)
Half throttle	VG33E only	ON [D ₄]	139 - 147 (86 - 91)	84 - 92 (52 - 57)
		OFF [D ₃]	74 - 82 (46 - 51)	71 - 79 (44 - 49)
	VG33ER only	ON [D ₄]	134 - 142 (83 - 88)	103 - 111 (64 - 69)
		OFF [D ₃]	86 - 94 (53 - 58)	83 - 91 (52 - 57)

Stall Revolution

NGAT0163

Stall revolution rpm	2,420 - 2,620
----------------------	---------------

SERVICE DATA AND SPECIFICATIONS (SDS)

Line Pressure

Line Pressure		
Engine speed rpm	Line pressure kPa (kg/cm ² , psi)	
	D, 2 and 1 positions	R position
Idle	422 - 461 (4.3 - 4.7, 61 - 67)	667 - 706 (6.8 - 7.2, 97 - 102)
Stall	1,020 - 1,098 (10.4 - 11.2, 148 - 159)	1,422 - 1,500 (14.5 - 15.3, 206 - 218)

NGAT0164

GI
MA
EM

LC

Return Springs

Unit: mm (in)

Parts				Item		
				Part No.*	Free length	Outer diameter
Control valve	Upper body	1	Torque converter relief valve spring	31742-41X23	38.0 (1.496)	9.0 (0.354)
		2	Pressure regulator valve spring	31742-41X24	44.02 (1.7331)	14.0 (0.551)
		3	Pressure modifier valve spring	31742-41X19	31.95 (1.2579)	6.8 (0.268)
		—	Accumulator control valve spring	—	—	—
		4	Shuttle shift valve D spring	31762-41X01	25.0 (0.984)	7.0 (0.276)
		5	4-2 sequence valve spring	31756-41X00	29.1 (1.146)	6.95 (0.2736)
		6	Shift valve B spring	31762-41X01	25.0 (0.984)	7.0 (0.276)
		7	4-2 relay valve spring	31756-41X00	29.1 (1.146)	6.95 (0.2736)
		8	Shift valve A spring	31762-41X01	25.0 (0.984)	7.0 (0.276)
		9	Overrun clutch control valve spring	31762-41X03 (VG33E only)	23.6 (0.929) (VG33E only)	7.0 (0.276)
		10	Overrun clutch reducing valve spring	31762-41X14 (VG33ER only) 31742-41X20	38.9 (1.531) (VG33ER only) 32.5 (1.280)	7.0 (0.276)
		11	Shuttle shift valve S spring	31762-41X04	51.0 (2.008)	5.65 (0.2224)
		12	Pilot valve spring	31742-41X13	25.7 (1.012)	9.0 (0.354)
13	Lock-up control valve spring	31742-41X22	18.5 (0.728)	13.0 (0.512)		
Control valve	Lower body	1	Modifier accumulator piston spring	31742-27X70	31.4 (1.236)	9.8 (0.386)
		2	1st reducing valve spring	31756-41X05 (VG33E only) 31756-60X60 (VG33ER only)	25.4 (1.000) (VG33E only) 29.5 (1.161) (VG33ER only)	6.75 (0.2657) (VG33E only) 7.00 (0.2756) (VG33ER only)
		3	3-2 timing valve spring	31742-41X06	23.0 (0.906)	6.7 (0.264)
		4	Servo charger valve spring	31742-41X06	23.0 (0.906)	6.7 (0.264)
Reverse clutch		16 pcs VG33E only 1 pc VG33ER only	31521-41X02 (Assembly) (VG33E only) 31505-41X07 (Assembly) (VG33ER only)	19.7 (0.7756) (VG33E only) — (VG33ER only)	11.6 (0.457) (VG33E only) — (VG33ER only)	
High clutch		10 pcs	31521-41X03 (Assembly)	24.2 (0.9528)	11.6 (0.457)	
Forward clutch (Overrun clutch)		20 pcs	31521-41X04 (Assembly)	35.77 (1.4083)	9.7 (0.382)	

EC

FE

CL

MT

AT

TF

PD

AX

SU

BR

ST

RS

BT

HA

SC

EL

IDX

SERVICE DATA AND SPECIFICATIONS (SDS)

Return Springs (Cont'd)

Parts			Item		
			Part No.*	Free length	Outer diameter
Low & reverse brake		18 pcs	31655-41X00 (Assembly)	22.3 (0.878)	11.2 (0.441)
Band servo		Spring A	31605-41X05 (VG33E only)	45.6 (1.795) (VG33E only)	34.3 (1.350) (VG33E only)
			31605-41X14 (VG33ER only)	47.6 (1.874) (VG33ER only)	26.5 (1.043) (VG33ER only)
		Spring B	31605-41X00 (VG33E only)	53.8 (2.118) (VG33E only)	40.3 (1.587) (VG33E only)
		Spring C	31605-41X01	29.7 (1.169)	27.6 (1.087)
Accumulator		Accumulator A	31605-41X02	43.0 (1.693)	18.0 (0.709)
		Accumulator B	31605-41X10 (VG33E only)	66.0 (2.598)	20.0 (0.787)
			31605-4AX03 (VG33ER only)		
		Accumulator C	31605-41X09	45.0 (1.772)	29.3 (1.154)
Accumulator D	31605-41X06	58.4 (2.299)	17.3 (0.681)		

*: Always check with the Parts Department for the latest parts information.

Accumulator O-ring

NGAT0166

Accumulator	Diameter mm (in)			
	A	B	C	D
Small diameter end	29 (1.14)	32 (1.26)	45 (1.77)	29 (1.14)
Large diameter end	45 (1.77)	50 (1.97)	50 (1.97)	45 (1.77)

Clutches and Brakes

NGAT0167

REVERSE CLUTCH

NGAT0167S01

Code number	43X64 (VG33E only)	4EX01, 4FX06 (VG33E only)	4EX67 (VG33ER only)	4EX68, 4FX07 (VG33ER only)
Number of drive plates	2			
Number of driven plates	2			
Thickness of drive plate mm (in)	Standard	1.90 - 2.05 (0.0748 - 0.0807)		
	Wear limit	1.80 (0.0709)		
Clearance mm (in)	Standard	0.5 - 0.8 (0.020 - 0.031)		
	Allowable limit	1.2 (0.047)		
Thickness of retaining plate	Thickness mm (in)	Part No.*	Thickness mm (in)	Part No.*
	4.8 (0.189)	31537-42X02	4.6 (0.181)	31537-42X20
	5.0 (0.197)	31537-42X03	4.8 (0.189)	31537-42X21
	5.2 (0.205)	31537-42X04	5.0 (0.197)	31537-42X22
	5.4 (0.213)	31537-42X05	5.2 (0.205)	31537-42X23
	5.6 (0.220)	31537-42X06	5.4 (0.213)	31537-42X24

*: Always check with the Parts Department for the latest parts information.

SERVICE DATA AND SPECIFICATIONS (SDS)

Clutches and Brakes (Cont'd)

HIGH CLUTCH

NGAT0167S02

Code number	43X64	4EX01, 4FX06	4EX67	4EX68, 4FX07
Number of drive plates	5			
Number of driven plates	5		6	
Thickness of drive plate mm (in)	Standard	1.52 - 1.67 (0.0598 - 0.0657)		
	Wear limit	1.40 (0.0551)		
Clearance mm (in)	Standard	1.8 - 2.2 (0.071 - 0.087)		
	Allowable limit	3.2 (0.126)		2.2 (0.087)
Thickness of retaining plate	Thickness mm (in)	Part No.*	Thickness mm (in)	Part No.*
	3.4 (0.134)	31537-41X71	4.0 (0.157)	31537-41X63
	3.6 (0.142)	31537-41X61	4.2 (0.165)	31537-41X64
	3.8 (0.150)	31537-41X62	4.4 (0.173)	31537-41X65
	4.0 (0.157)	31537-41X63	4.6 (0.181)	31537-41X66
	4.2 (0.165)	31537-41X64	4.8 (0.189)	31537-41X67
	4.4 (0.173)	31537-41X65	5.0 (0.197)	31537-41X68
	4.6 (0.181)	31537-41X66		
4.8 (0.189)	31537-41X67			

*: Always check with the Parts Department for the latest parts information.

FORWARD CLUTCH

NGAT0167S03

Code number	43X64 (VG33E only)	4EX01, 4FX06 (VG33E only)	4EX67 (VG33ER only)	4EX68, 4FX07 (VG33ER only)				
Number of drive plates	6	7	7	8				
Number of driven plates	6	7	7	8				
Thickness of drive plate mm (in)	Standard	1.52 - 1.67 (0.0598 - 0.0657)						
	Wear limit	1.40 (0.0551)						
Clearance mm (in)	Standard	0.35 - 0.75 (0.0138 - 0.0295)						
	Allowable limit	1.95 (0.0768)	2.15 (0.0846)	2.15 (0.0846)	2.35 (0.0925)			
Thickness of retaining plate	Thickness mm (in)	Part No.*	Thickness mm (in)	Part No.*	Thickness mm (in)	Part No.*	Thickness mm (in)	Part No.*
	8.0 (0.315)	31537-41X00	4.6 (0.181)	31537-42X13	4.6 (0.181)	31537-42X13	4.2 (0.165)	31537-42X11
	8.1 (0.319)	41X00	4.8 (0.189)	42X13	4.8 (0.189)	42X13	4.4 (0.173)	42X11
	8.2 (0.323)	31537-42X60	5.0 (0.197)	31537-42X14	5.0 (0.197)	31537-42X14	4.6 (0.181)	31537-42X12
	8.3 (0.327)	42X60	5.2 (0.205)	42X14	5.2 (0.205)	42X14	4.8 (0.189)	42X12
	8.4 (0.331)	31537-41X01	5.4 (0.213)	31537-42X15	5.4 (0.213)	31537-42X15	5.0 (0.197)	31537-42X13
	8.5 (0.335)	41X01	5.6 (0.220)	42X15	5.6 (0.220)	42X15	5.2 (0.205)	42X13
	8.6 (0.339)	31537-42X61		31537-4AX00		31537-4AX00	5.4 (0.213)	31537-42X14
	8.7 (0.343)	42X61		4AX00		4AX00		42X14
	8.8 (0.346)	31537-41X02		31537-4AX01		31537-4AX01		31537-42X15
	8.9 (0.350)	41X02		4AX01		4AX01		42X15
	9.0 (0.354)	31537-42X62		31537-4AX02		31537-4AX02		31537-4AX00
	9.1 (0.358)	42X62		4AX02		4AX02		4AX00
	9.2 (0.362)	31537-41X03						31537-4AX01
		31537-42X63						
		31537-41X04						
		31537-42X64						
	31537-41X05							
	31537-42X65							
	31537-41X06							

*: Always check with the Parts Department for the latest parts information.

SERVICE DATA AND SPECIFICATIONS (SDS)

Clutches and Brakes (Cont'd)

OVERRUN CLUTCH

NGAT0167S04

Code number		43X64 (VG33E only)	4EX01, 4FX06 (VG33E only)	4EX67 (VG33ER only)	4EX68, 4FX07 (VG33ER only)
Number of drive plates		3			
Number of driven plates		5			
Thickness of drive plate mm (in)	Standard	1.90 - 2.05 (0.0748 - 0.0807)			
	Wear limit	1.80 (0.0709)			
Clearance mm (in)	Standard	1.0 - 1.4 (0.039 - 0.055)			
	Allowable limit	2.4 (0.094)			
Thickness of retaining plate		Thickness mm (in)		Part No.*	
		4.2 (0.165)	4.4 (0.173)	4.6 (0.181)	4.8 (0.189)

*: Always check with the Parts Department for the latest parts information.

LOW & REVERSE BRAKE

NGAT0167S05

Code number		43X64 (VG33E only)	4EX01, 4FX06 (VG33E only)	4EX67 (VG33ER only)	4EX68, 4FX07 (VG33ER only)											
Number of drive plates		7		8												
Number of driven plates		7		8												
Thickness of drive plate mm (in)	Standard	1.52 - 1.67 (0.0598 - 0.0657)														
	Wear limit	1.40 (0.0551)														
Clearance mm (in)	Standard	0.8 - 1.1 (0.031 - 0.043)														
	Allowable limit	2.5 (0.098)		2.7 (0.106)												
Thickness of retaining plate		Thickness mm (in)		Part No.*												
		6.6 (0.260)	6.8 (0.268)	7.0 (0.276)	7.2 (0.283)	7.4 (0.291)	7.6 (0.299)	7.8 (0.307)	8.0 (0.315)	8.2 (0.323)	8.4 (0.331)	8.6 (0.339)	8.8 (0.346)	9.0 (0.354)	9.2 (0.362)	9.4 (0.370)

*: Always check with the Parts Department for the latest parts information.

BRAKE BAND

NGAT0167S06

Anchor end bolt tightening torque	4 - 6 N-m (0.4 - 0.6 kg-m, 35 - 52 in-lb)
Number of returning revolution for anchor end bolt	2.5

SERVICE DATA AND SPECIFICATIONS (SDS)

Oil Pump and Low One-way Clutch

Oil Pump and Low One-way Clutch

Unit: mm (in) ^{NGAT0168}

Oil pump clearance	Cam ring — oil pump housing	Standard	0.01 - 0.024 (0.0004 - 0.0009)
	Rotor, vanes and control piston — oil pump housing	Standard	0.03 - 0.044 (0.0012 - 0.0017)
Seal ring clearance		Standard	0.10 - 0.25 (0.0039 - 0.0098)
		Allowable limit	0.25 (0.0098)

Total End Play

^{NGAT0169}

Total end play "T ₁ "	0.25 - 0.55 mm (0.0098 - 0.0217 in)	
Thickness of oil pump cover bearing race	Thickness mm (in)	Part No.*
	0.8 (0.031)	31435-41X01
	1.0 (0.039)	31435-41X02
	1.2 (0.047)	31435-41X03
	1.4 (0.055)	31435-41X04
	1.6 (0.063)	31435-41X05
	1.8 (0.071)	31435-41X06
	2.0 (0.079)	31435-41X07

*: Always check with the Parts Department for the latest parts information.

Reverse Clutch Drum End Play

^{NGAT0170}

Reverse clutch drum end play "T ₂ "	0.55 - 0.90 mm (0.0217 - 0.0354 in)	
Thickness of oil pump thrust washer	Thickness mm (in)	Part No.*
	0.9 (0.035)	31528-21X01
	1.1 (0.043)	31528-21X02
	1.3 (0.051)	31528-21X03
	1.5 (0.059)	31528-21X04
	1.7 (0.067)	31528-21X05
	1.9 (0.075)	31528-21X06

*: Always check with the Parts Department for the latest parts information.

Removal and Installation

^{NGAT0171}

Manual control linkage	Number of returning revolutions for lock nut	2
	Lock nut tightening torque	4.4 - 5.9 N·m (0.45 - 0.60 kg·m, 39.1 - 52.1 in·lb)
Distance between end of clutch housing and torque converter		26.0 mm (1.024 in) or more (VG33E only) 25.0 mm (0.984 in) or more (VG33ER only)

Shift Solenoid Valves

^{NGAT0210}

Gear position	1	2	3	4
Shift solenoid valve A	ON (Closed)	OFF (Open)	OFF (Open)	ON (Closed)
Shift solenoid valve B	ON (Closed)	ON (Closed)	OFF (Open)	OFF (Open)

Solenoid Valves

^{NGAT0211}

Solenoid valves	Resistance (Approx.) Ω	Terminal No.
Shift solenoid valve A	20 - 40	3
Shift solenoid valve B	20 - 40	2
Overrun clutch solenoid valve	20 - 40	4
Line pressure solenoid valve	2.5 - 5	6

SERVICE DATA AND SPECIFICATIONS (SDS)

A/T Fluid Temperature Sensor

Torque converter clutch solenoid valve	10 - 20	7
--	---------	---

A/T Fluid Temperature Sensor

NGAT0212

Remarks: Specification data are reference values.

Monitor item	Condition	Specification (Approx.)	
A/T fluid temperature sensor	Cold [20°C (68°F)]	1.5V	2.5 kΩ
	↓ Hot [80°C (176°F)]	↓ 0.5V	↓ 0.3 kΩ

Turbine Revolution Sensor

NGAT0220

Terminal No.		Resistance (Approx.)
1	2	2.4 - 2.8 KΩ
1	3	No continuity
2	3	No continuity

Revolution Sensor

NGAT0213

Terminal No.		Resistance (Approx.)
1	2	500 - 650Ω
2	3	No continuity
1	3	No continuity

Dropping Resistor

NGAT0214

Resistance	Approx. 12Ω
------------	-------------