

TF
SECTION
TRANSFER

A
B
C

TF

CONTENTS

E

PRECAUTIONS 4		
Precautions for Supplemental Restraint System (SRS) "AIR BAG" and "SEAT BELT PRE-TENSIONER" 4		
Precautions for Transfer Assembly and Transfer Control Unit Replacement 4		
CHECK 4WD SHIFT INDICATOR PATTERN 4		
METHOD FOR ADJUSTMENT WITH 4WD SHIFT SWITCH AT "2WD" 5		
METHOD FOR ADJUSTMENT WITH 4WD SHIFT SWITCH AT "4H" OR "4LO" 5		
Precautions 6		
Service Notice 6		
PREPARATION 8		
Special Service Tools 8		
Commercial Service Tools 10		
NOISE, VIBRATION AND HARSHNESS (NVH)		
TROUBLESHOOTING11		
NVH Troubleshooting Chart 11		
TRANSFER FLUID 12		
Replacement 12		
DRAINING 12		
FILLING 12		
Inspection 12		
FLUID LEAKAGE AND FLUID LEVEL 12		
4WD SYSTEM 13		
Cross-section View 13		
Power Transfer 14		
POWER TRANSFER DIAGRAM 14		
POWER TRANSFER FLOW 15		
System Description 15		
TRANSFER CONTROL DEVICE 15		
WAIT DETECTION SWITCH 15		
4LO SWITCH 15		
ATP SWITCH (A/T MODELS) 15		
PNP SWITCH (M/T MODELS) 15		
TRANSFER CONTROL UNIT 15		
TRANSFER SHIFT HIGH AND LOW RELAYS... 15		
TRANSFER SHUT OFF RELAYS 15		
4WD SHIFT SWITCH AND INDICATOR LAMP.. 16		
	4WD WARNING LAMP 17	
	ATP WARNING LAMP (FOR A/T MODELS) 17	
	System Diagram 18	
	COMPONENTS FUNCTION 18	
	CAN Communication 19	
	SYSTEM DESCRIPTION 19	
	TROUBLE DIAGNOSIS 20	
	How to Perform Trouble Diagnosis 20	
	BASIC CONCEPT 20	
	Location of Electrical Parts 21	
	Schematic — M/T MODELS — 23	
	Wiring Diagram — T/F — 24	
	M/T MODELS 24	
	Schematic — A/T MODELS — 30	
	Wiring Diagram — T/F — 31	
	A/T MODELS 31	
	Trouble Diagnosis Chart for Symptoms 37	
	Transfer Control Unit Input/Output Signal Reference Values 37	
	TRANSFER CONTROL UNIT INSPECTION TABLE 37	
	CONSULT-II Function (ALL MODE AWD/4WD) 44	
	FUNCTION 44	
	CONSULT-II SETTING PROCEDURE 44	
	SELF-DIAG RESULT MODE 45	
	DATA MONITOR MODE 46	
	Self-Diagnostic Procedure 47	
	SELF-DIAGNOSTIC PROCEDURE (WITH CONSULT-II) 47	
	SELF-DIAGNOSTIC PROCEDURE (WITHOUT CONSULT-II) 47	
	ERASE SELF-DIAGNOSIS 50	
	TROUBLE DIAGNOSIS FOR SYSTEM 51	
	Power Supply Circuit For Transfer Control Unit 51	
	CONSULT-II REFERENCE VALUE IN DATA MONITOR MODE 51	
	TRANSFER CONTROL UNIT TERMINALS AND REFERENCE VALUE 51	
	DIAGNOSTIC PROCEDURE 52	
	COMPONENT INSPECTION 54	

F
G
H
I
J
K
L
M

Transfer Control Unit	54	COMPONENT INSPECTION	87
DIAGNOSTIC PROCEDURE	54	Park/Neutral Position Switch (M/T Models)	87
Output Shaft Revolution Signal (TCM)	54	TRANSFER CONTROL UNIT TERMINALS AND	
DIAGNOSTIC PROCEDURE	54	REFERENCE VALUE	87
Vehicle Speed Sensor (ABS)	55	DIAGNOSTIC PROCEDURE	87
DIAGNOSTIC PROCEDURE	55	COMPONENT INSPECTION	89
4LO Switch	56	TROUBLE DIAGNOSIS FOR SYMPTOMS	90
CONSULT-II REFERENCE VALUE IN DATA		4WD Shift Indicator Lamp and 4LO Indicator Lamp	
MONITOR MODE	56	Do Not Turn ON	90
TRANSFER CONTROL UNIT TERMINALS AND		SYMPTOM:	90
REFERENCE VALUE	56	DIAGNOSTIC PROCEDURE	91
DIAGNOSTIC PROCEDURE	57	4WD Warning Lamp Does Not Turn ON	93
COMPONENT INSPECTION	59	SYMPTOM:	93
4WD Shift Switch	59	DIAGNOSTIC PROCEDURE	94
CONSULT-II REFERENCE VALUE IN DATA		4WD Shift Indicator Lamp or 4LO Indicator Lamp	
MONITOR MODE	59	Do Not Change	96
TRANSFER CONTROL UNIT TERMINALS AND		SYMPTOM:	96
REFERENCE VALUE	59	DIAGNOSTIC PROCEDURE	97
DIAGNOSTIC PROCEDURE	60	ATP Warning Lamp Does Not Turn ON	98
COMPONENT INSPECTION	63	SYMPTOM:	98
Wait Detection Switch	63	DIAGNOSTIC PROCEDURE	98
CONSULT-II REFERENCE VALUE IN DATA		4WD Shift Indicator Lamp Repeats Flashing	100
MONITOR MODE	63	SYMPTOM:	100
TRANSFER CONTROL UNIT TERMINALS AND		DIAGNOSTIC PROCEDURE	100
REFERENCE VALUE	63	4WD Warning Lamp Flashes Slowly	100
DIAGNOSTIC PROCEDURE	64	SYMPTOM:	100
COMPONENT INSPECTION	67	DIAGNOSTIC PROCEDURE	101
PNP Switch Signal (A/T models)	67	TRANSFER CONTROL UNIT	102
DIAGNOSTIC PROCEDURE	67	Removal and Installation	102
Actuator Motor	68	REMOVAL	102
CONSULT-II REFERENCE VALUE IN DATA		INSTALLATION	102
MONITOR MODE	68	FRONT OIL SEAL	103
TRANSFER CONTROL UNIT TERMINALS AND		Removal and Installation	103
REFERENCE VALUE	68	REMOVAL	103
DIAGNOSTIC PROCEDURE	70	INSTALLATION	104
COMPONENT INSPECTION	76	REAR OIL SEAL	105
Actuator Position Switch	77	Removal and Installation	105
CONSULT-II REFERENCE VALUE IN DATA		REMOVAL	105
MONITOR MODE	77	INSTALLATION	105
TRANSFER CONTROL UNIT TERMINALS AND		TRANSFER CONTROL DEVICE	107
REFERENCE VALUE	77	Removal and Installation	107
DIAGNOSTIC PROCEDURE	78	REMOVAL	107
Transfer Control Device	80	INSTALLATION	107
CONSULT-II REFERENCE VALUE IN DATA		AIR BREATHER HOSE	109
MONITOR MODE	80	Removal and Installation	109
TRANSFER CONTROL UNIT TERMINALS AND		TRANSFER ASSEMBLY	111
REFERENCE VALUE	80	Removal and Installation	111
DIAGNOSTIC PROCEDURE	81	REMOVAL	111
Engine Speed Signal	83	INSTALLATION	111
DIAGNOSTIC PROCEDURE	83	Disassembly and Assembly	112
CAN Communication Line	84	COMPONENTS	112
DIAGNOSTIC PROCEDURE	84	DISASSEMBLY	114
ATP Switch	84	INSPECTION AFTER DISASSEMBLY	119
CONSULT-II REFERENCE VALUE IN DATA		ASSEMBLY	120
MONITOR MODE	84	PLANETARY CARRIER	129
TRANSFER CONTROL UNIT TERMINALS AND		Disassembly and Assembly	129
REFERENCE VALUE	84	DISASSEMBLY	129
DIAGNOSTIC PROCEDURE	85	INSPECTION AFTER DISASSEMBLY	130
		ASSEMBLY	131

FRONT DRIVE SHAFT	133	SERVICE DATA AND SPECIFICATIONS (SDS) ...	138	
Disassembly and Assembly	133	General Specifications	138	A
DISASSEMBLY	133	Inspection and Adjustment	138	
INSPECTION AFTER DISASSEMBLY	133	PINION GEAR END PLAY	138	
ASSEMBLY	134	CLEARANCE BETWEEN SHIFT FORK AND		B
SHIFT CONTROL	135	SLEEVE	138	
Disassembly and Assembly	135			C
DISASSEMBLY (A/T MODELS)	135			
DISASSEMBLY (M/T MODELS)	135			
INSPECTION AFTER DISASSEMBLY	136			
ASSEMBLY (A/T MODELS)	136			
ASSEMBLY (M/T MODELS)	137			

TF

E

F

G

H

I

J

K

L

M

PRECAUTIONS

PRECAUTIONS

PF:00001

Precautions for Supplemental Restraint System (SRS) “AIR BAG” and “SEAT BELT PRE-TENSIONER”

EDS002M4

The Supplemental Restraint System such as “AIR BAG” and “SEAT BELT PRE-TENSIONER”, used along with a front seat belt, helps to reduce the risk or severity of injury to the driver and front passenger for certain types of collision. This system includes seat belt switch inputs and dual stage front air bag modules. The SRS system uses the seat belt switches to determine the front air bag deployment, and may only deploy one front air bag, depending on the severity of a collision and whether the front occupants are belted or unbelted. Information necessary to service the system safely is included in the SRS and SB section of this Service Manual.

WARNING:

- To avoid rendering the SRS inoperative, which could increase the risk of personal injury or death in the event of a collision which would result in air bag inflation, all maintenance must be performed by an authorized NISSAN/INFINITI dealer.
- Improper maintenance, including incorrect removal and installation of the SRS, can lead to personal injury caused by unintentional activation of the system. For removal of Spiral Cable and Air Bag Module, see the SRS section.
- Do not use electrical test equipment on any circuit related to the SRS unless instructed to in this Service Manual. SRS wiring harnesses can be identified by yellow and/or orange harnesses or harness connectors.





Precautions for Transfer Assembly and Transfer Control Unit Replacement

EDS002M5

When replacing transfer assembly or transfer control unit, check the 4WD shift indicator pattern and adjustment of the position between transfer assembly and transfer control unit if necessary.

CHECK 4WD SHIFT INDICATOR PATTERN

1. Set 4WD shift switch to “2WD”, “4H”, “4LO”, “4H” and “2WD” in order. Stay at each switch position for at least 2 seconds.
2. Confirm 4WD shift indicator lamp and 4LO indicator lamp change properly as follows.

4WD shift switch	Indicator lamp		Operation of 4WD shift switch
	4WD shift	4LO	
2WD		OFF	2WD ⇌ 4H switching can be done while driving. The indicator lamp will change when the driving mode is changed. Gear shifting between 2WD ⇌ 4H position must be performed at speeds below 100 km/h (60MPH).
4H			
4LO		Flashing	For M/T models, to shift between 4H ⇌ 4LO, stop the vehicle and shift the transmission shift lever to the Neutral position with the clutch pedal depressed. For A/T models, to shift between 4H ⇌ 4LO, stop the vehicle and shift the transmission selector to the "N" with the brake pedal depressed.
		ON	Depress and turn the 4WD shift switch. The 4WD shift switch will not shift to the desired mode if the transmission is not in "N" or the vehicle is moving. You must wait for the 4LO indicator lamp to stop flashing and remain lit or turned off before shifting your transmission into gear or releasing the clutch pedal.

SDIA3289E

- If OK, the position between transfer assembly and transfer control unit is correct.
- If NG, the position is different between transfer assembly and transfer control unit.
Adjust the position between transfer assembly and transfer control unit. Refer to pattern table below.

PRECAUTIONS

Transfer position adjustment pattern

4WD shift switch condition	Refer procedure
4WD shift switch is in "2WD" when engine is stopped.	TF-5, "METHOD FOR ADJUSTMENT WITH 4WD SHIFT SWITCH AT "2WD" "
4WD shift switch is in "4H" or "4LO" when engine is stopped.	TF-5, "METHOD FOR ADJUSTMENT WITH 4WD SHIFT SWITCH AT "4H" OR "4LO" "

NOTE:

Method of adjustment can be chosen voluntarily, according to location of 4WD shift switch.

METHOD FOR ADJUSTMENT WITH 4WD SHIFT SWITCH AT "2WD"

Select Adjustment Pattern

1. Start engine. Run engine for at least 10 seconds.
2. Check 4WD shift indicator lamp and 4LO indicator lamp.

Indicator lamp condition	Refer procedure
When 4WD shift indicator lamp or 4LO indicator lamp is flashing.	TF-5, "Pattern A"
Except for above.	TF-5, "Pattern B"

Pattern A

1. Shift the transmission according to the directions below, and stay in "N" for at least 2 seconds.
 - For A/T models, stop vehicle and move A/T selector lever to "N" position with brake pedal depressed.
 - For M/T models, stop vehicle and move M/T shift lever to the neutral position with brake and clutch pedal depressed.
2. Turn 4WD shift switch to "4LO" position. Stay in "4LO" for at least 2 seconds.
3. Turn ignition switch "OFF".
4. Start engine.
5. Erase self-diagnosis. Refer to [TF-46, "How to Erase Self-diagnostic Results"](#) (with CONSULT-II) or [TF-50, "ERASE SELF-DIAGNOSIS"](#) (without CONSULT-II).
6. Check 4WD shift indicator lamp and 4LO indicator lamp again. Refer to [TF-4, "CHECK 4WD SHIFT INDICATOR PATTERN"](#).
If 4WD shift indicator lamp and 4LO indicator lamp do not indicate proper pattern, install new transfer control unit and retry the above check.

Pattern B

1. Shift the transmission according to the directions below, and stay in "N" for at least 2 seconds.
 - For A/T models, stop vehicle and move A/T selector lever to "N" position with brake pedal depressed.
 - For M/T models, stop vehicle and move M/T shift lever to the neutral position with brake and clutch pedal depressed.
2. Turn ignition switch "OFF".
3. Start engine.
4. Erase self-diagnosis. Refer to [TF-46, "How to Erase Self-diagnostic Results"](#) (with CONSULT-II) or [TF-50, "ERASE SELF-DIAGNOSIS"](#) (without CONSULT-II).
5. Check 4WD shift indicator lamp and 4LO indicator lamp again. Refer to [TF-4, "CHECK 4WD SHIFT INDICATOR PATTERN"](#).
If 4WD shift indicator lamp and 4LO indicator lamp do not indicate proper pattern, install new transfer control unit and retry the above check.

METHOD FOR ADJUSTMENT WITH 4WD SHIFT SWITCH AT "4H" OR "4LO"

1. Start engine. Run the engine for at least 10 seconds.
2. Shift the transmission according to the directions below, and stay in "N" for at least 2 seconds.
 - For A/T models, stop vehicle and move A/T selector lever to "N" position with brake pedal depressed.
 - For M/T models, stop vehicle and move M/T shift lever to the neutral position with brake and clutch pedal depressed.
3. Turn 4WD shift switch to "2WD" position. Stay in "2WD" for at least 2 seconds.
4. Turn ignition switch "OFF".

PRECAUTIONS

5. Start engine.
6. Erase self-diagnosis. Refer to [TF-46, "How to Erase Self-diagnostic Results"](#) (with CONSULT-II) or [TF-50, "ERASE SELF-DIAGNOSIS"](#) (without CONSULT-II).
7. Check 4WD shift indicator lamp and 4LO indicator lamp again. Refer to [TF-4, "CHECK 4WD SHIFT INDICATOR PATTERN"](#).
If 4WD shift indicator lamp and 4LO indicator lamp do not indicate proper pattern, install new transfer control unit and retry the above check.

Precautions

EDS002M6

- Before connecting or disconnecting the transfer control unit harness connector, turn ignition switch "OFF" and disconnect the battery cables. Battery voltage is applied to transfer control unit even if ignition switch is turned "OFF".

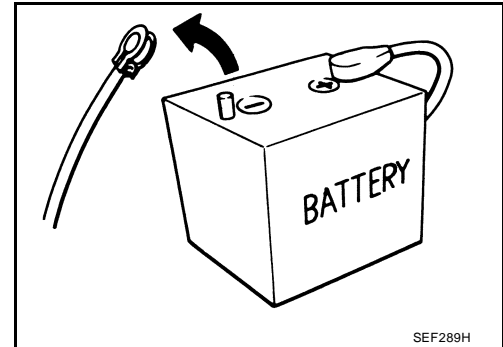

- When connecting or disconnecting pin connectors into or from transfer control unit, take care not to damage pin terminals (bend or break).
When connecting pin connectors make sure that there are not any bends or breaks on transfer control unit pin terminals.

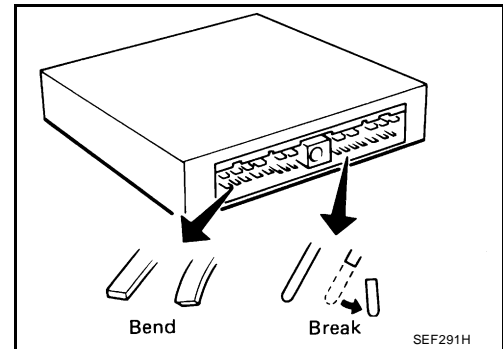

- Before replacing transfer control unit, perform transfer control unit input/output signal inspection and make sure transfer control unit functions properly. Refer to [TF-37, "Transfer Control Unit Input/Output Signal Reference Values"](#).

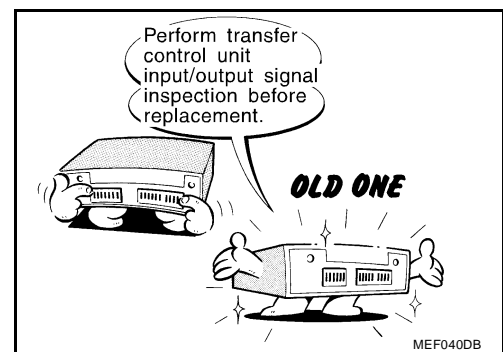

Service Notice

EDS002M7

- After overhaul refill the transfer with new transfer fluid.
- Check the fluid level or replace the fluid only with the vehicle parked on level ground.
- During removal or installation, keep inside of transfer clear of dust or dirt.
- Disassembly should be done in a clean work area.
- Before proceeding with disassembly, thoroughly clean the transfer. It is important to prevent the internal parts from becoming contaminated by dirt or other foreign matter.
- Check for the correct installation status prior to removal or disassembly. If matchmarks are required, be certain they do not interfere with the function of the parts when applied.
- All parts should be carefully cleaned with a general purpose, non-flammable solvent before inspection or reassembly.

PRECAUTIONS

-
- Check appearance of the disassembled parts for damage, deformation, and unusual wear. Replace them with a new ones if necessary. A
 - Gaskets, seals and O-rings should replaced any time the transfer is disassembled.
 - In principle, tighten bolts or nuts gradually in several steps working diagonally from inside to outside. If tightening sequence is specified, use it. B
 - Observe the specified torque when assembling.
 - Clean and flush the parts sufficiently and blow-dry them.
 - Be careful not to damage sliding surfaces and mating surfaces. C
 - Use lint-free cloth or towels for wiping parts clean. Common shop rags can leave fibers that could interfere with the operation of the transfer. TF

E

F

G

H

I

J

K

L

M

PREPARATION

PFP:00002

PREPARATION

Special Service Tools

EDS002M9

The actual shapes of Kent-Moore tools may differ from those of special service tools illustrated here.

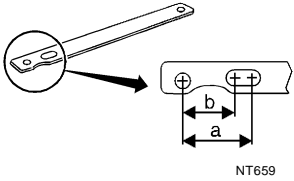
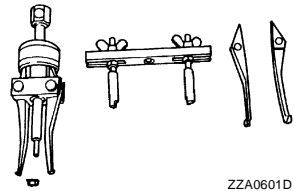
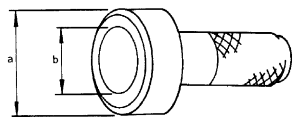
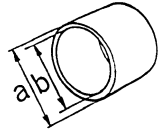
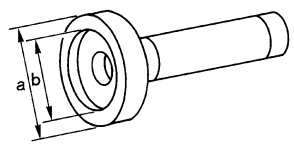
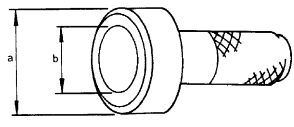
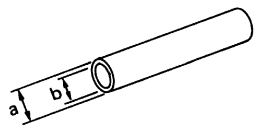
Tool number (Kent-Moore No.) Tool name		Description
KV40104000 (—) Flange wrench		<ul style="list-style-type: none"> ● Removing self-lock nut ● Installing self-lock nut <p>a: 85 mm (3.35 in) b: 65 mm (2.56 in)</p>
KV381054S0 (J-34286) Puller		<ul style="list-style-type: none"> ● Removing front oil seal ● Removing rear oil seal ● Removing metal bushing
KV38100500 (—) Drift		<ul style="list-style-type: none"> ● Installing front oil seal ● Installing rear oil seal ● Installing rear bearing ● Installing front bearing <p>a: 80 mm (3.15 in) dia. b: 60 mm (2.36 in) dia.</p>
KV40105310 (—) Drift		<ul style="list-style-type: none"> ● Installing dust cover <p>a: 89 mm (3.50 in) dia. b: 80.7 mm (3.17 in) dia.</p>
KV38100200 (—) Drift		<ul style="list-style-type: none"> ● Removing sun gear assembly and planetary carrier assembly ● Removing input bearing ● Installing sun gear assembly and planetary carrier assembly <p>a: 65 mm (2.56 in) dia. b: 49 mm (1.93 in) dia.</p>
ST30720000 (J-25405) Drift		<ul style="list-style-type: none"> ● Installing input bearing ● Installing input oil seal ● Installing carrier bearing <p>a: 77 mm (3.03 in) dia. b: 55 mm (2.17 in) dia.</p>
KV32102700 (—) Drift		<ul style="list-style-type: none"> ● Installing mainshaft rear bearing <p>a: 48 mm (1.89 in) dia. b: 41 mm (1.61 in) dia.</p>

PREPARATION

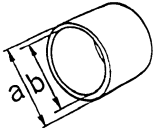
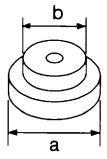
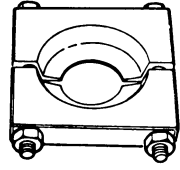
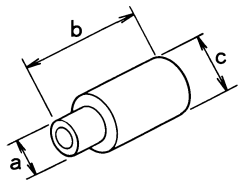
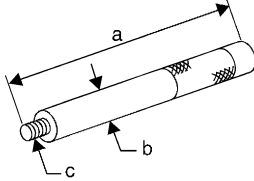
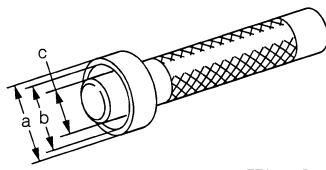
Tool number (Kent-Moore No.) Tool name	Description	
KV40104830 (—) Drift <div style="text-align: center;">  <p style="margin: 0;">ZZA1003D</p> </div>	<ul style="list-style-type: none"> ● Installing input oil seal a: 70 mm (2.76 in) dia. b: 63.5 mm (2.50 in) dia. 	A B C
ST35300000 (—) Drift <div style="text-align: center;">  <p style="margin: 0;">NT073</p> </div>	<ul style="list-style-type: none"> ● Removing carrier bearing ● Installing metal bushing ● Removing front bearing a: 59 mm (2.32 in) dia. b: 45 mm (1.77 in) dia. 	TF E
ST30021000 (J-22912-01) Puller <div style="text-align: center;">  <p style="margin: 0;">ZZA0537D</p> </div>	<ul style="list-style-type: none"> ● Removing carrier bearing ● Removing front bearing ● Removing rear bearing 	F G H
ST33710000 (—) Drift <div style="text-align: center;">  <p style="margin: 0;">ZZA1057D</p> </div>	<ul style="list-style-type: none"> ● Removing needle bearing ● Removing metal bushing ● Removing rear bearing a: 24 mm (0.94 in) b: 89 mm (3.5 in) dia. c: 30 mm (1.18 in) dia. 	I J
ST35325000 (—) Drift bar <div style="text-align: center;">  <p style="margin: 0;">NT663</p> </div>	<ul style="list-style-type: none"> ● Removing metal bushing a: 215 mm (8.46 in) b: 25 mm (0.98 in) dia. c: M12 × 1.5P 	K L
ST33220000 (—) Drift <div style="text-align: center;">  <p style="margin: 0;">ZZA1046D</p> </div>	<ul style="list-style-type: none"> ● Installing needle bearing a: 37 mm (1.46 in) dia. b: 31 mm (1.22 in) dia. c: 22 mm (0.87 in) dia. 	M

PREPARATION

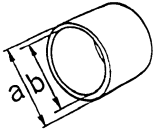
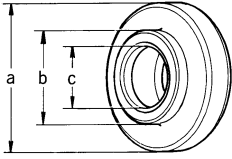
Tool number (Kent-Moore No.) Tool name	Description
ST27863000 (—) Drift	<ul style="list-style-type: none"> ● Installing carrier bearing <p>a: 75 mm (2.95 in) dia. b: 62 mm (2.44 in) dia.</p>
 <p style="text-align: right; margin-right: 50px;">ZZA1003D</p>	
ST30901000 (J-26010-01) Drift	<ul style="list-style-type: none"> ● Installing rear bearing ● Installing front bearing <p>a: 79 mm (3.11 in) dia. b: 45 mm (1.77 in) dia. c: 35.2 mm (1.38 in) dia.</p>
 <p style="text-align: right; margin-right: 50px;">ZZA0978D</p>	

Commercial Service Tools

EDS002MA

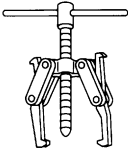
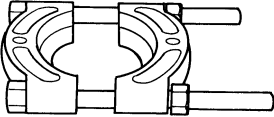
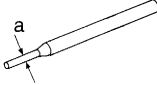
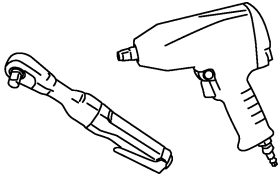
Tool name	Description
Puller	<ul style="list-style-type: none"> ● Removing companion flange ● Removing mainshaft rear bearing
 <p style="text-align: right; margin-right: 50px;">NT077</p>	
Puller	<ul style="list-style-type: none"> ● Removing mainshaft rear bearing
 <p style="text-align: right; margin-right: 50px;">ZZB0823D</p>	
Pin punch	<ul style="list-style-type: none"> ● Removing retaining pin <p>a: 6 mm (0.24 in) dia.</p>
 <p style="text-align: right; margin-right: 50px;">NT410</p>	
Power tool	<ul style="list-style-type: none"> ● Loosening bolts and nuts
 <p style="text-align: right; margin-right: 50px;">PBIC0190E</p>	

NOISE, VIBRATION AND HARSHNESS (NVH) TROUBLESHOOTING

NOISE, VIBRATION AND HARSHNESS (NVH) TROUBLESHOOTING

PDF:00003

NVH Troubleshooting Chart

EDS002MB

Use the chart below to help you find the cause of the symptom. The numbers indicate the order of the inspection. If necessary, repair or replace these parts.

Reference page		TF-12			TF-112			TF-136	TF-120	TF-130
SUSPECTED PARTS (Possible cause)		TRANSFER FLUID (Level low)	TRANSFER FLUID (Wrong)	TRANSFER FLUID (Level too high)	LIQUID GASKET (Damaged)	O-RING (Worn or damaged)	OIL SEAL (Worn or damaged)	SHIFT FORK (Worn or damaged)	GEAR (Worn or damaged)	BEARING (Worn or damaged)
Symptom	Noise	1	2						3	3
	Transfer fluid leakage		3	1	2	2	2			
	Hard to shift or will not shift		1	1				2		

A
B
C
TF
E
F
G
H
I
J
K
L
M

TRANSFER FLUID

TRANSFER FLUID

PFP:31001

Replacement DRAINING

EDS002MC

1. Stop engine.
2. Remove the drain plug and gasket. Drain the fluid.
3. Install the drain plug with a new gasket to the transfer. Tighten to the specified torque. Refer to [TF-112, "COMPONENTS"](#).

CAUTION:
Do not reuse gasket.

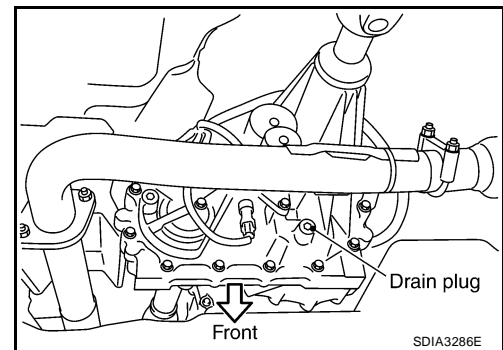

FILLING

1. Remove the filler plug and gasket.
2. Fill the transfer with new fluid until the fluid level reaches the specified limit near the filler plug hole.

Fluid grade and capacity : Refer to [MA-11, "Fluids and Lubricants"](#).

CAUTION:
Carefully fill fluid. (Fill up for approx. 3 minutes.)

3. Leave the vehicle for 3 minutes, and check fluid level again.
4. Install the filler plug with a new gasket to the transfer. Tighten to the specified torque. Refer to [TF-112, "COMPONENTS"](#).

CAUTION:
Do not reuse gasket.

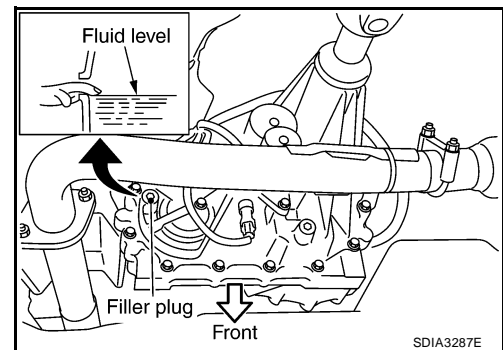

Inspection FLUID LEAKAGE AND FLUID LEVEL

EDS002MD

1. Make sure that fluid is not leaking from the transfer assembly or around it.
2. Check fluid level from the filler plug hole as shown.

CAUTION:
Do not start engine while checking fluid level.

3. Install the filler plug with a new gasket to the transfer. Tighten to the specified torque. Refer to [TF-112, "COMPONENTS"](#).

CAUTION:
Do not reuse gasket.

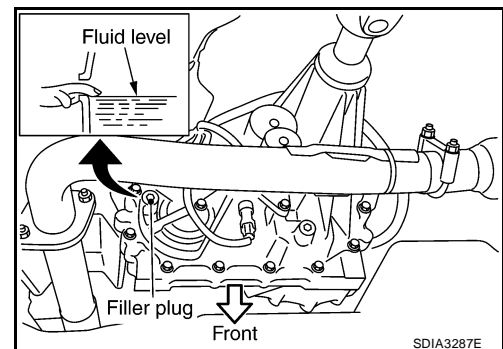

4WD SYSTEM

PFP:33084

4WD SYSTEM

Cross-section View

EDS003LO

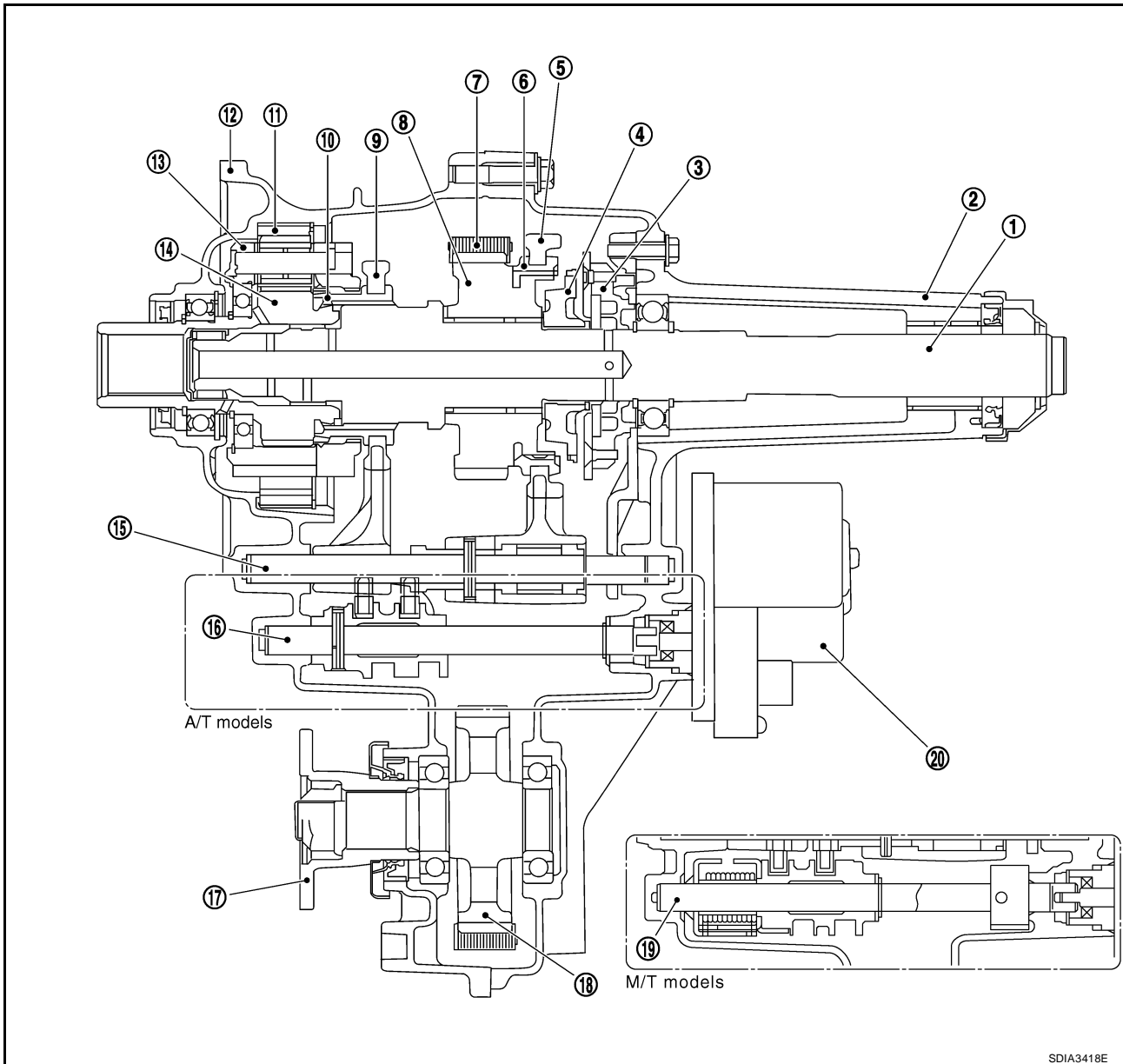

- | | | |
|------------------------------------|-----------------------------|-----------------------|
| 1. Mainshaft | 2. Rear case | 3. Oil pump assembly |
| 4. Clutch gear | 5. 2-4 shift fork | 6. 2-4 sleeve |
| 7. Drive chain | 8. Sprocket | 9. L-H shift fork |
| 10. L-H sleeve | 11. Internal gear | 12. Front case |
| 13. Planetary carrier assembly | 14. Sun gear assembly | 15. L-H shift rod |
| 16. Control shift rod (A/T models) | 17. Companion flange | 18. Front drive shaft |
| 19. Control shift rod (M/T models) | 20. Transfer control device | |

SDIA3418E

4WD SYSTEM

EDS002MF

Power Transfer POWER TRANSFER DIAGRAM

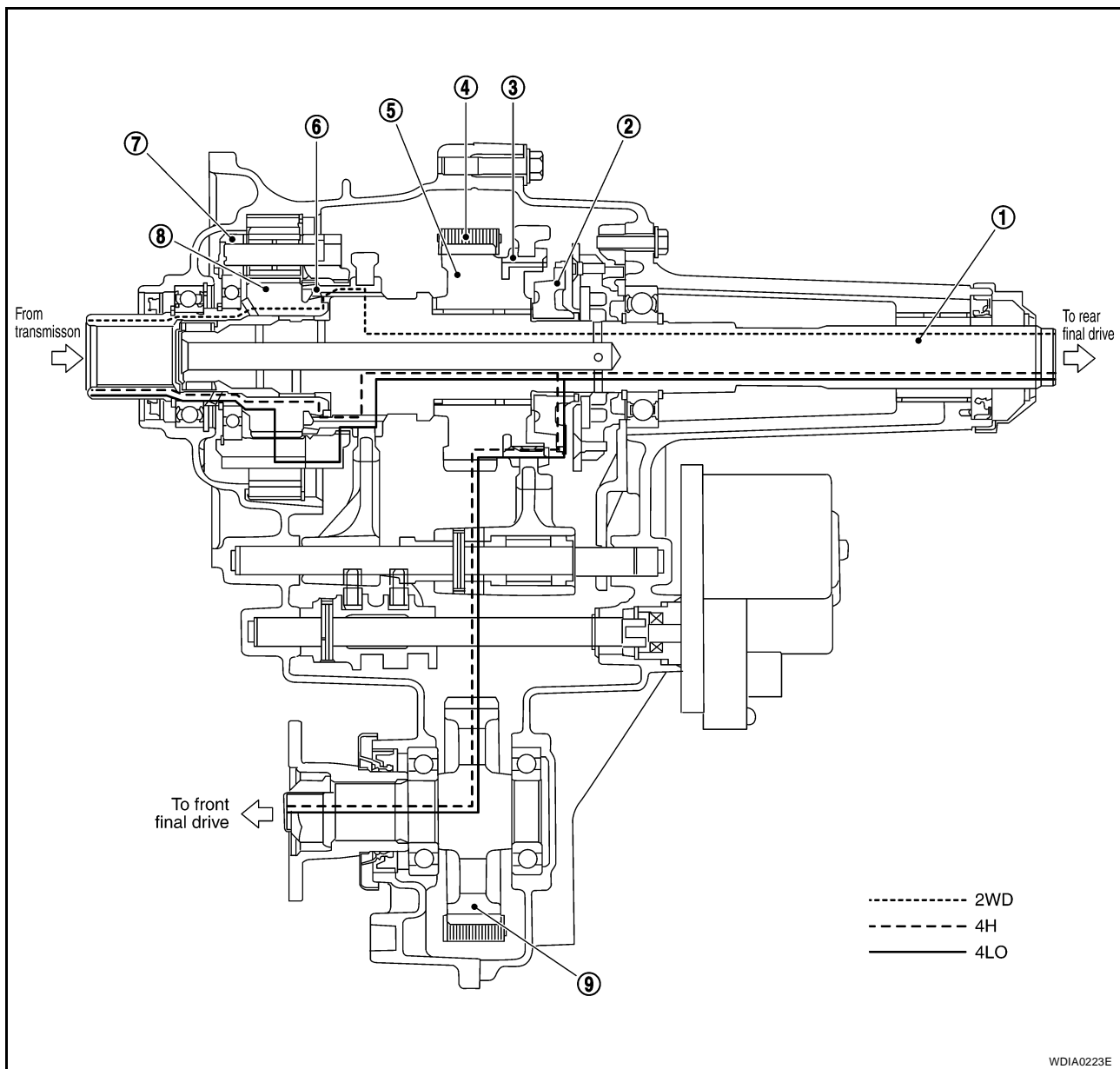

WDIA0223E

- | | | |
|-------------------------------|----------------------|----------------------|
| 1. Mainshaft | 2. Clutch gear | 3. 2-4 sleeve |
| 4. Drive chain | 5. Sprocket | 6. L-H sleeve |
| 7. Planetary carrier assembly | 8. Sun gear assembly | 9. Front drive shaft |

4WD SYSTEM

POWER TRANSFER FLOW

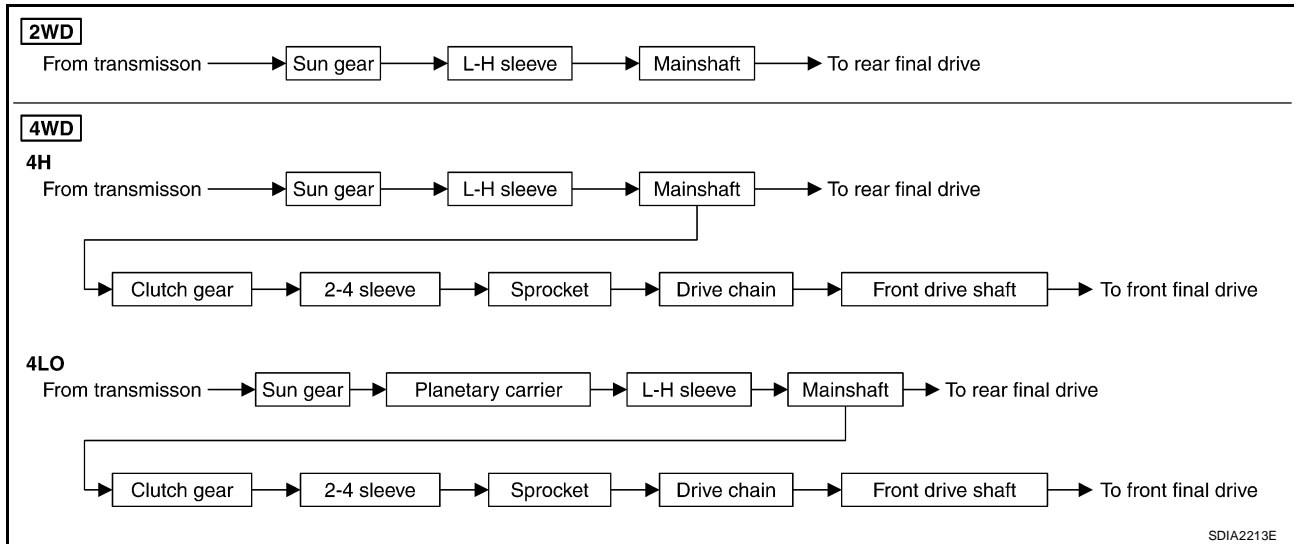

System Description TRANSFER CONTROL DEVICE

EDS002XK

Actuator motor and actuator position switch are integrated. Transfer control device shifts from 4H-4LO and between 2WD-4WD.

Actuator Motor

Actuator motor is operated by signal from transfer control unit and it operates control shift rod so as to shift from 4H-4LO and between 2WD-4WD.

Actuator Position Switch

Actuator position switch detects actuator motor position and sends it to transfer control unit.

WAIT DETECTION SWITCH

Wait detection switch detects if transfer gear is in 4WD by 2-4 shift fork position.

NOTE:

If 4WD shift switch is switched to 4H or 4LO, transfer is not in 4WD completely when gear does not engage. (Wait detection system is operating.)

4LO SWITCH

4LO switch detects if transfer gear is under 4LO condition by L-H shift fork position.

ATP SWITCH (A/T MODELS)

ATP switch detects if transfer gear is under neutral condition by L-H shift fork position.

NOTE:

Transfer gear may be under neutral condition when shifting between 4H-4LO.

PNP SWITCH (M/T MODELS)

PNP switch detects if manual transmission is under neutral condition.

TRANSFER CONTROL UNIT

- Transfer control unit controls transfer control device by input signals of each sensor and each switch, and it directs shifts from 4H-4LO and 2WD-4WD.
- Self-diagnosis can be done.

TRANSFER SHIFT HIGH AND LOW RELAYS





Transfer shift high and low relays apply power supply to transfer control device (actuator motor).

TRANSFER SHUT OFF RELAYS

Transfer shut off relays 1 and 2 apply power supply to transfer control unit.

4WD SYSTEM

4WD SHIFT SWITCH AND INDICATOR LAMP

4WD shift switch	Indicator lamp		Operation of 4WD shift switch	Use condition
	4WD shift	4LO		
2WD		OFF	2WD⇌4H switching can be done while driving. The indicator lamp will change when the driving mode is changed. Gear shift in between 2WD⇌4H position must be performed at speeds below 100 km/h (60 MPH).	For driving on dry, paved roads.
4H				For driving on rough, sandy or snow-covered roads.
4LO		Flashing	For M/T models, to shift between 4H⇌4LO, stop the vehicle and shift the transmission shift lever to the Neutral position with the clutch pedal depressed. For A/T models, to shift between 4H⇌4LO, stop the vehicle and shift the transmission selector to the "N" position with the brake pedal depressed. Depressed and turn the 4WD shift switch. The 4WD shift switch will not shift to the desired mode if the transmission is not in "N" or the vehicle is moving. You must wait for the 4LO indicator lamp to stop flashing and remain lit or turned off before shifting your transmission into gear or releasing the clutch pedal.	The 4LO indicator lamp flashes when shifting between 4LO⇌4H.
		ON	For use when maximum power and traction is required at low speeds (for example on steep grades or rocky, sandy, muddy roads.).	

SDIA3290E

4WD Shift Switch

4WD shift switch is able to select from 2WD, 4H or 4LO.

4WD Shift Indicator Lamp

- Displays driving conditions selected by 4WD shift switch with front, rear and center indicators, while engine is running. When shifting from 4H to 4LO, 4LO indicator lamp also turns on. And when 4WD warning lamp is turned on, all 4WD shift indicator lamps are turned off.
- Turns ON when ignition switch is turned ON, for purpose of lamp check. Turns OFF approximately 1 second after the engine starts if system is normal.

4LO Indicator Lamp

- Displays 4LO condition while engine is running and 4WD shift switch is in 4LO. 4LO indicator lamp flashes if transfer gear does not shift completely under 4H⇌4LO. In this condition, transfer may be under neutral condition and A/T parking mechanism may not operate.
- Turns ON when ignition switch is turned ON, for purpose of lamp check. Turns OFF approximately 1 second after the engine starts if system is normal.

4WD SYSTEM

4WD WARNING LAMP

Turns ON or FLASH when there is a malfunction in 4WD system.

Also turns ON when ignition switch is turned ON, for purpose of lamp check. Turns OFF approximately for 1 second after the engine starts if system is normal.

4WD Warning Lamp Indication

Condition	4WD warning lamp
Lamp check	Turns ON when ignition switch is turned ON. Turns OFF after engine start.
4WD system malfunction	ON (For indicated malfunction items, see the "NOTE")
During self-diagnosis	Flickers at malfunction mode.
Large difference in diameter of front/rear tires	Slow flashing: 1 time/2 seconds (Continues to flash until turning ignition switch OFF)
Other than above (system normal)	OFF

NOTE:

4WD warning lamp is turned on when one or more of the following parts are malfunctioning.

- Vehicle speed signal [from ABS actuator and electric unit (control unit)]
- CAN communication line
- AD converter
- Engine speed signal
- 4WD shift switch
- Wait detection switch
- Actuator motor
- Transfer control device
- Transfer shut off relays
- Transfer shift high and low relays
- PNP switch signal

ATP WARNING LAMP (FOR A/T MODELS)

When A/T selector lever is in "P" position, vehicle may move because A/T parking mechanism does not operate when transfer is under neutral condition. ATP warning lamp is turned on to indicate this condition to the driver.

4WD SYSTEM

System Diagram

EDS002XL

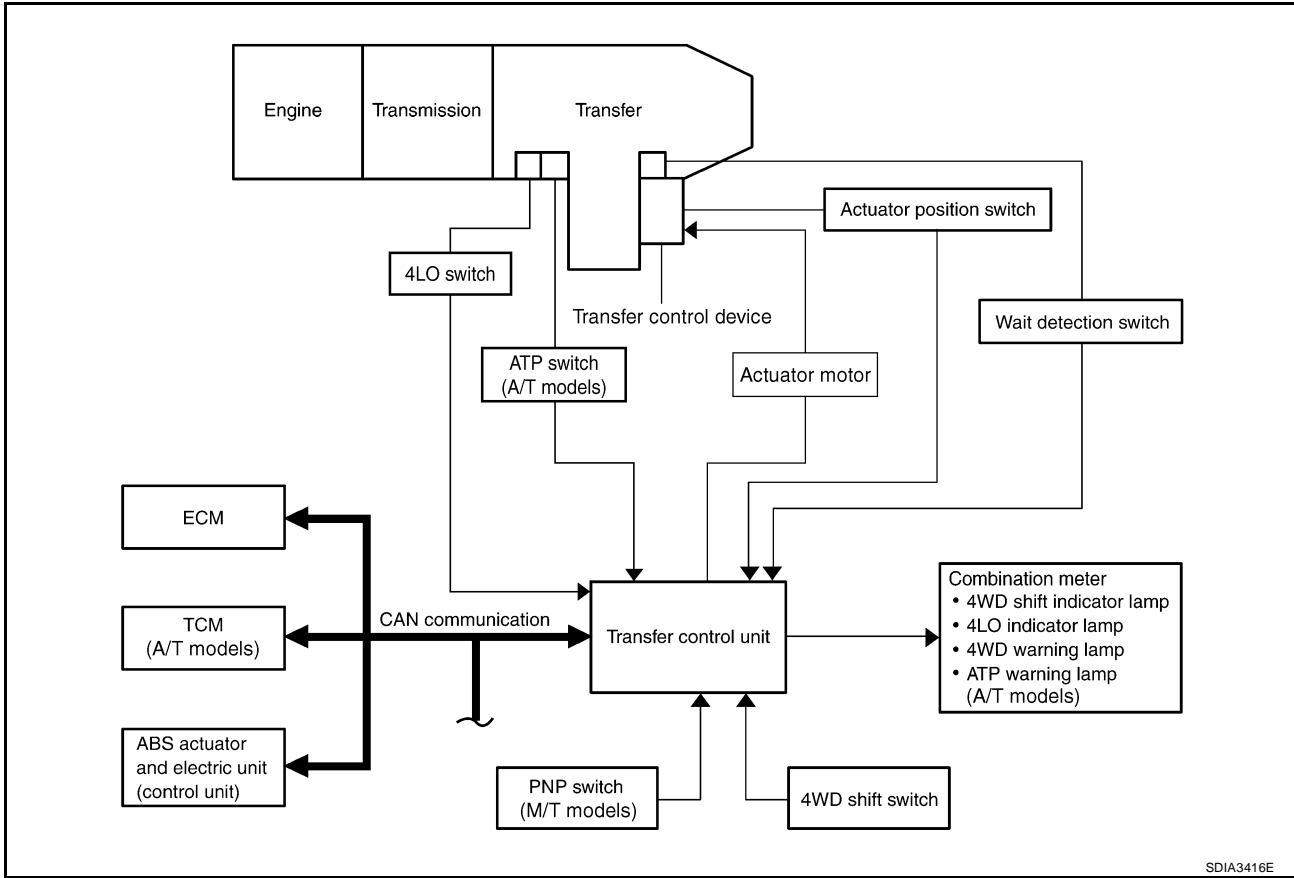

SDIA3416E

COMPONENTS FUNCTION

Component parts	Function
Transfer control unit	Controls transfer control device and switches 4H-4LO under 4WD condition and 2WD-4WD.
Transfer control device	Actuator motor and actuator position switch are integrated so as to switch driving types.
Actuator motor	Controls shift rods by signals from transfer control unit.
Actuator position switch	Detects actuator motor position.
Wait detection switch	Detects if transfer is under 4WD condition.
4LO switch	Detects if transfer is under 4LO condition.
ATP switch (A/T models)	Detects if transfer is under neutral condition.
4WD shift switch	Able to select from 2WD, 4H or 4LO.
4WD warning lamp	<ul style="list-style-type: none"> ● Illuminates if malfunction is detected in electrical system of 4WD system. ● There is 1 blink in 2 seconds if rotation difference of front wheels and rear wheels is large.
ATP warning lamp (A/T models)	Indicates that A/T parking mechanism does not operate when A/T selector lever is in "P" position and transfer is under neutral condition.
4WD shift indicator lamp	Displays driving condition selected by 4WD shift switch.
4LO indicator lamp	Displays 4LO condition.
PNP switch (M/T models)	Detects if manual transmission is under neutral condition.
ABS actuator and electric unit (control unit)	Transmits the following signals via CAN communication to Transfer control unit. <ul style="list-style-type: none"> ● Vehicle speed signal ● Stop lamp switch signal (brake signal)

4WD SYSTEM

Component parts	Function
TCM (A/T models)	Transmits the following signal via CAN communication to Transfer control unit. <ul style="list-style-type: none">● Output shaft revolution signal● A/T position indicator signal (PNP switch signal)
ECM	Transmits engine speed signal via CAN communication to Transfer control unit.

CAN Communication SYSTEM DESCRIPTION

EDS002MI

Refer to [LAN-21, "CAN COMMUNICATION"](#) .

A
B
C
TF
E
F
G
H
I
J
K
L
M

TROUBLE DIAGNOSIS

How to Perform Trouble Diagnosis BASIC CONCEPT

- To perform trouble diagnosis, it is the most important to have understanding about vehicle systems (control and mechanism) thoroughly.
- It is also important to clarify customer complaints before inspection.

First of all, reproduce symptoms, and understand them fully. Ask customer about his/her complaints carefully. In some cases, it will be necessary to check symptoms by driving vehicle with customer.

CAUTION:

Customers are not professional. It is dangerous to make an easy guess like "maybe the customer means that...," or "maybe the customer mentions this symptom".

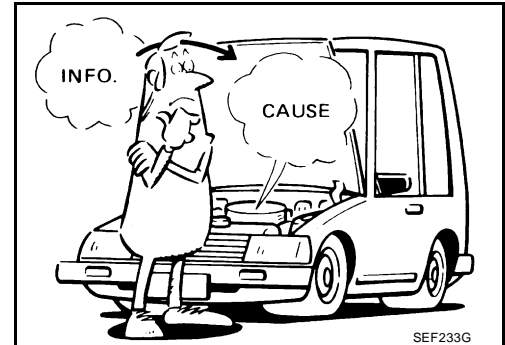

- It is essential to check symptoms right from the beginning in order to repair malfunctions completely. For intermittent malfunctions, reproduce symptoms based on interview with customer and past examples. Do not perform inspection on ad hoc basis. Most intermittent malfunctions are caused by poor contacts. In this case, it will be effective to shake suspected harness or connector by hand. When repairing without any symptom diagnosis, you cannot judge if malfunctions have actually been eliminated.
- After completing diagnosis, always erase diagnostic memory. Refer to [TF-50, "ERASE SELF-DIAGNOSIS"](#).
- For intermittent malfunctions, move harness or harness connector by hand. Then check for poor contact or reproduced open circuit.

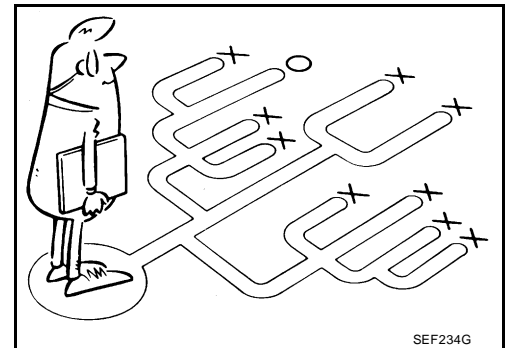

TROUBLE DIAGNOSIS

Location of Electrical Parts

EDS003LP

A
B
C
TF
E
F
G
H
I
J
K
L
M

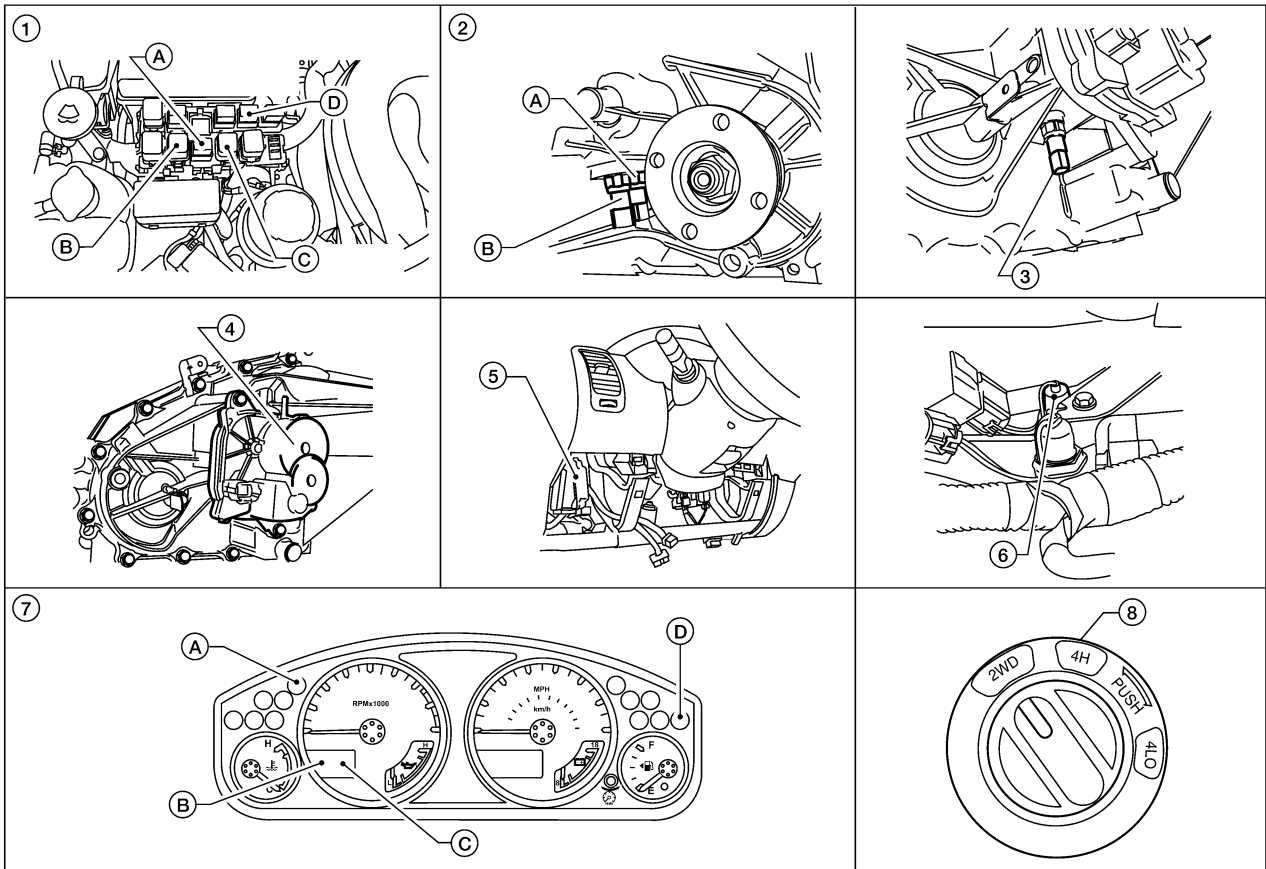
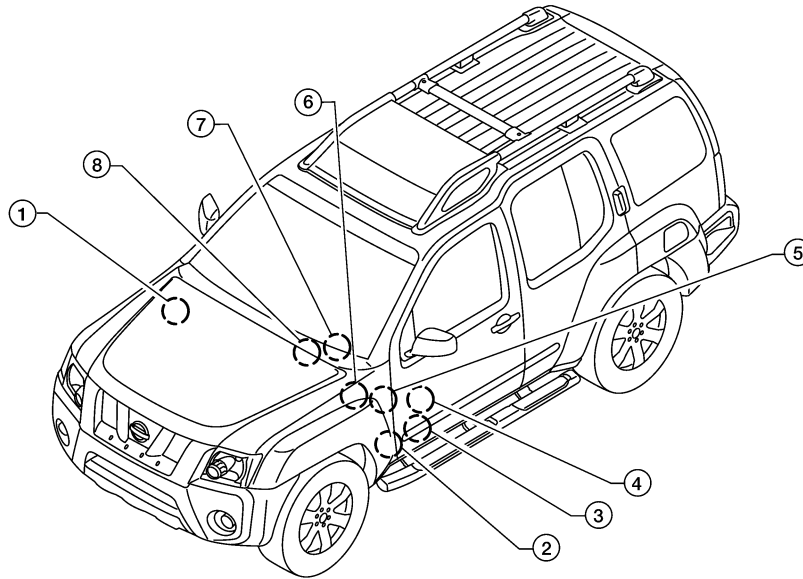

WDIA0348E

TROUBLE DIAGNOSIS

1. Fuse and relay box
 - A: Transfer shut off relay 1 E156
 - B: Transfer shift high relay E46
 - C: Transfer shift low relay E47
 - D: Transfer shut off relay 2 E157
2. A: ATP switch F55 (A/T models)
B: 4 LO switch F60
(View with front propeller shaft removed.)
3. Wait detection switch F59
4. Transfer control device F58
5. Transfer control unit M152, M153
(View with lower instrument cover LH removed.)
6. Park/neutral position switch F56
(M/T models)
7. Combination meter M24
 - A: 4WD warning lamp
 - B: 4LO indicator lamp
 - C: 4WD shift indicator lamp
 - D: ATP warning lamp (A/T models)
8. 4WD shift switch M141

TROUBLE DIAGNOSIS

Schematic — M/T MODELS —

EDS00321

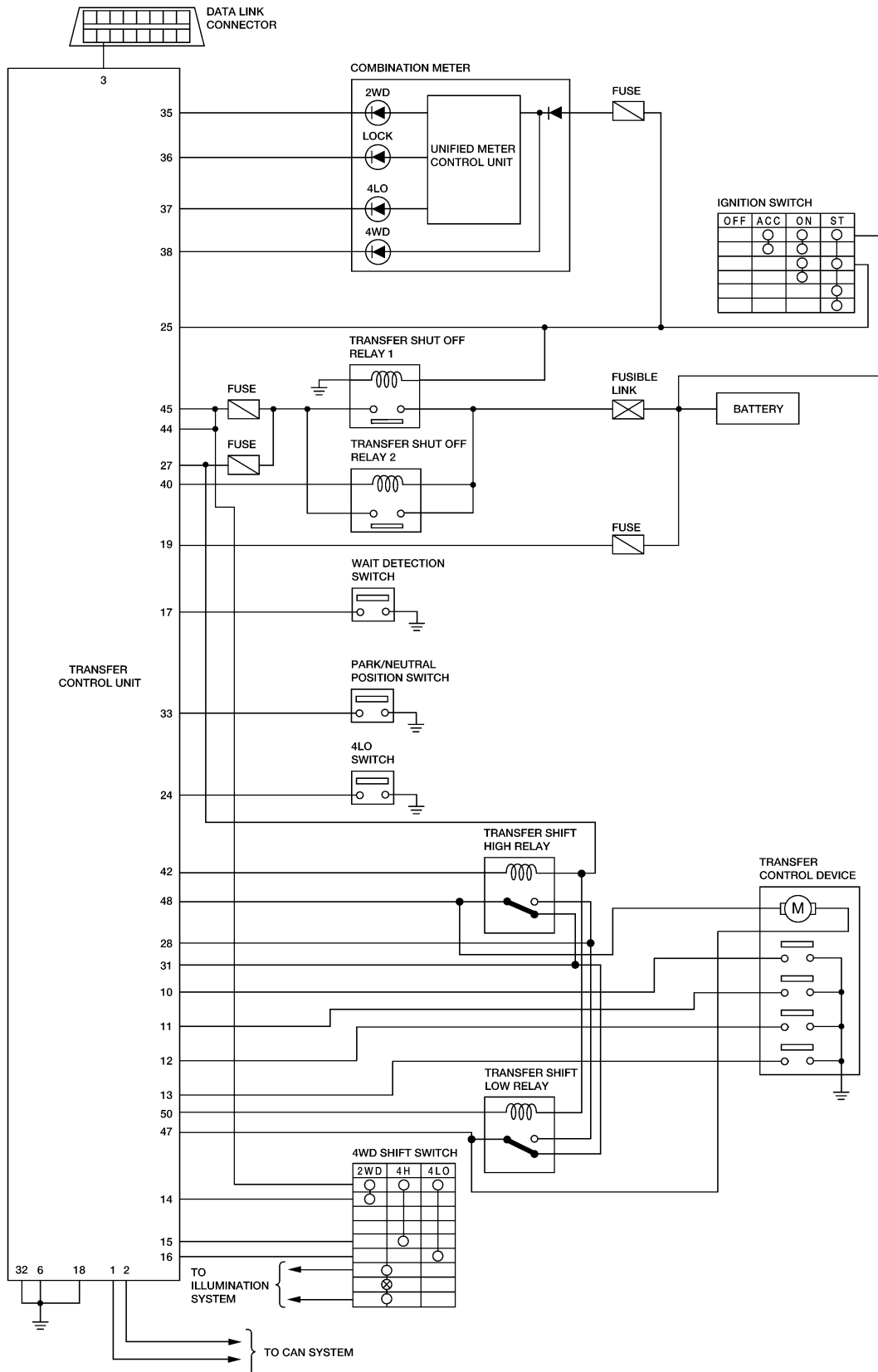

A
B
C
TF
E
F
G
H
I
J
K
L
M

BDWA0135E

TROUBLE DIAGNOSIS

EDS0032J

Wiring Diagram — T/F — M/T MODELS

TF-T/F-01

— : DETECTABLE LINE FOR DTC
— : NON-DETECTABLE LINE FOR DTC

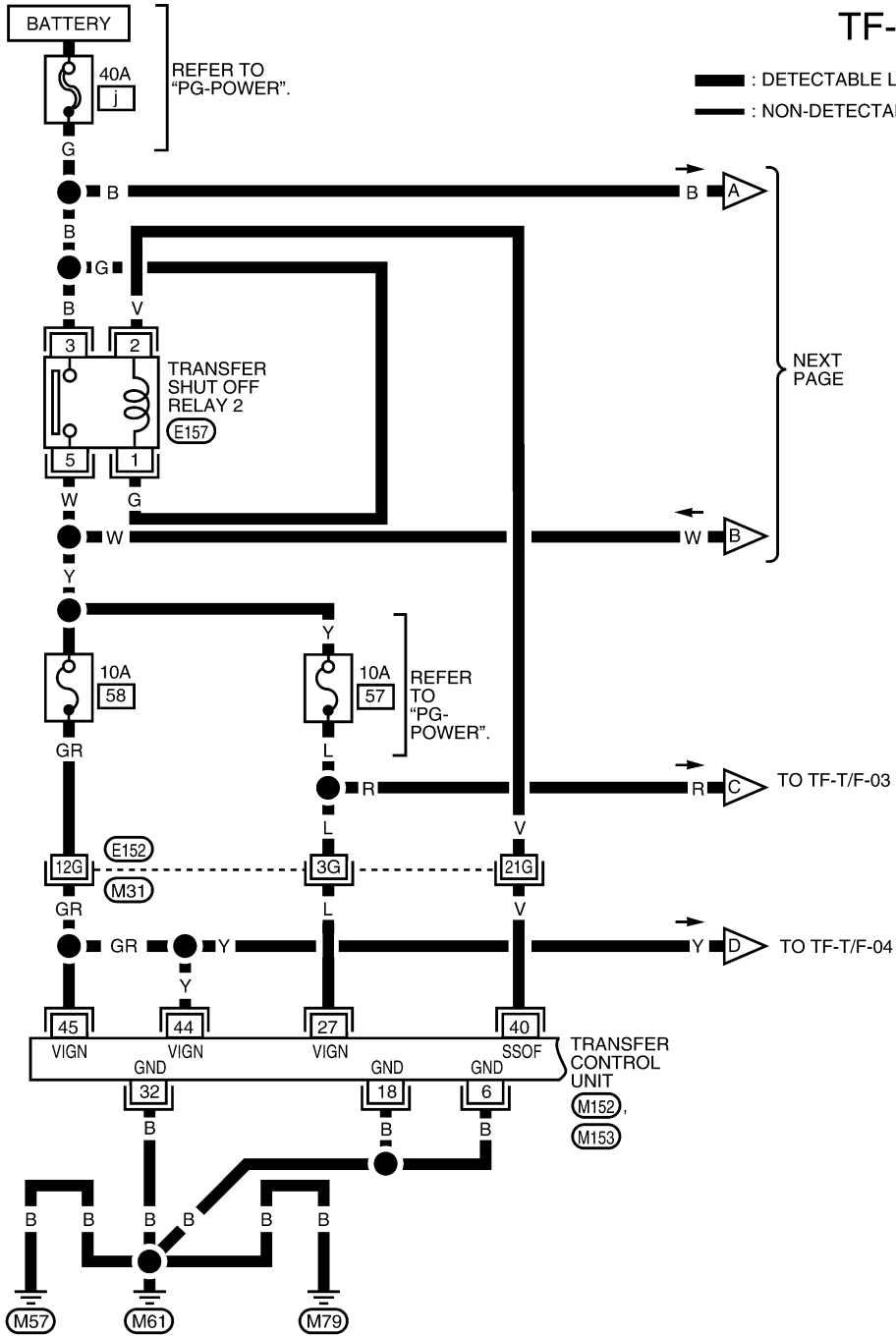

NEXT PAGE

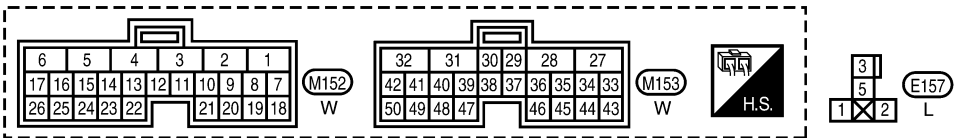

REFER TO THE FOLLOWING.
(M31) - SUPER MULTIPLE JUNCTION (SMJ)

TROUBLE DIAGNOSIS

TF-T/F-02

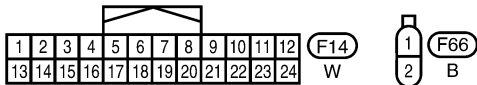
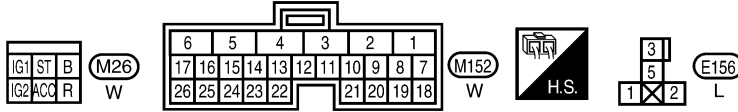
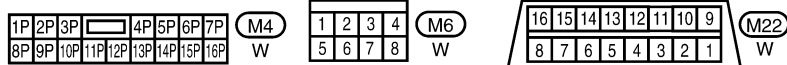
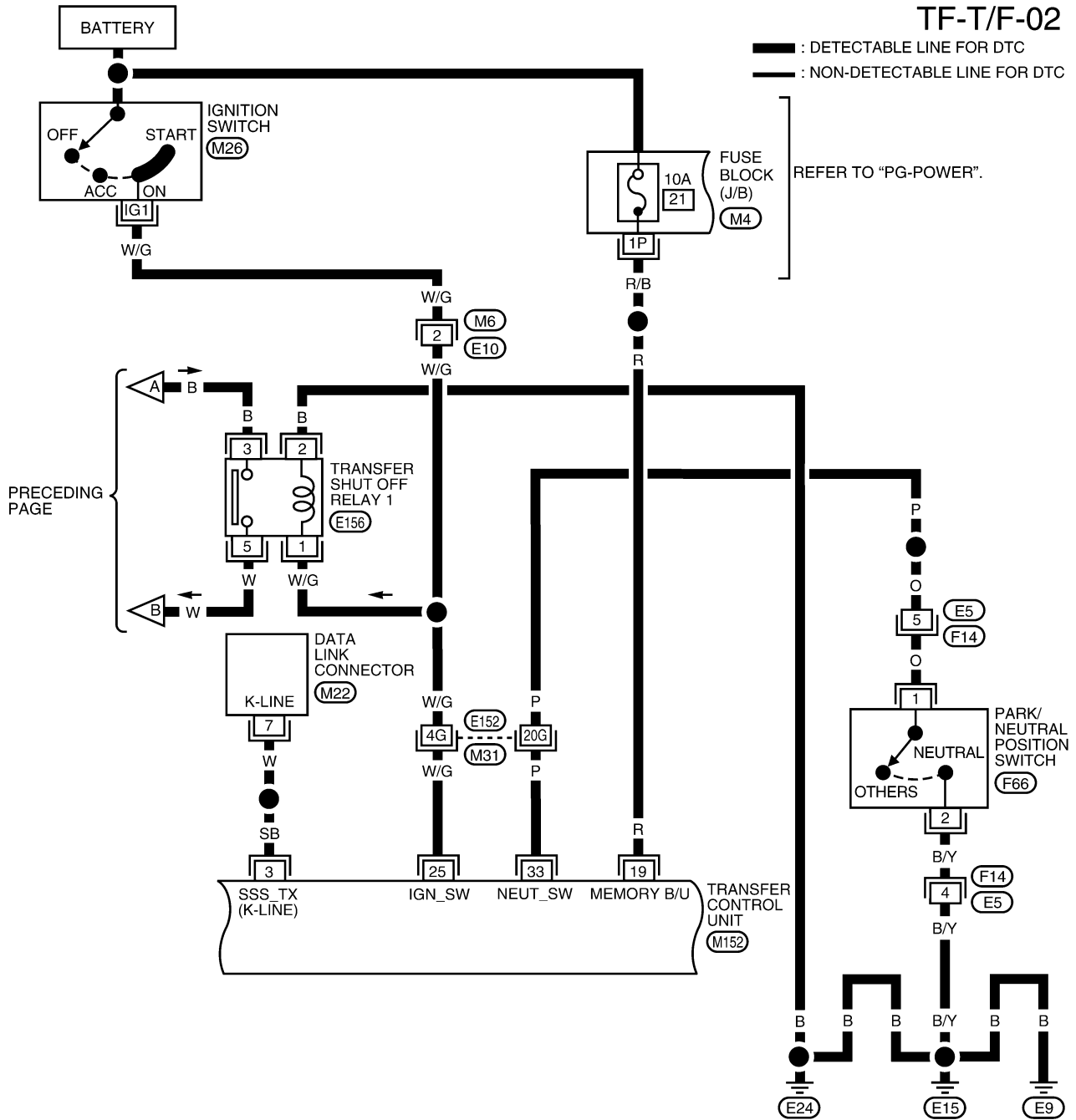

REFER TO THE FOLLOWING.
(M31) - SUPER MULTIPLE JUNCTION (SMJ)

BDWA0195E

TROUBLE DIAGNOSIS

TF-T/F-03

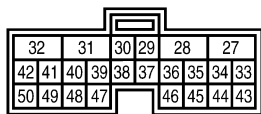
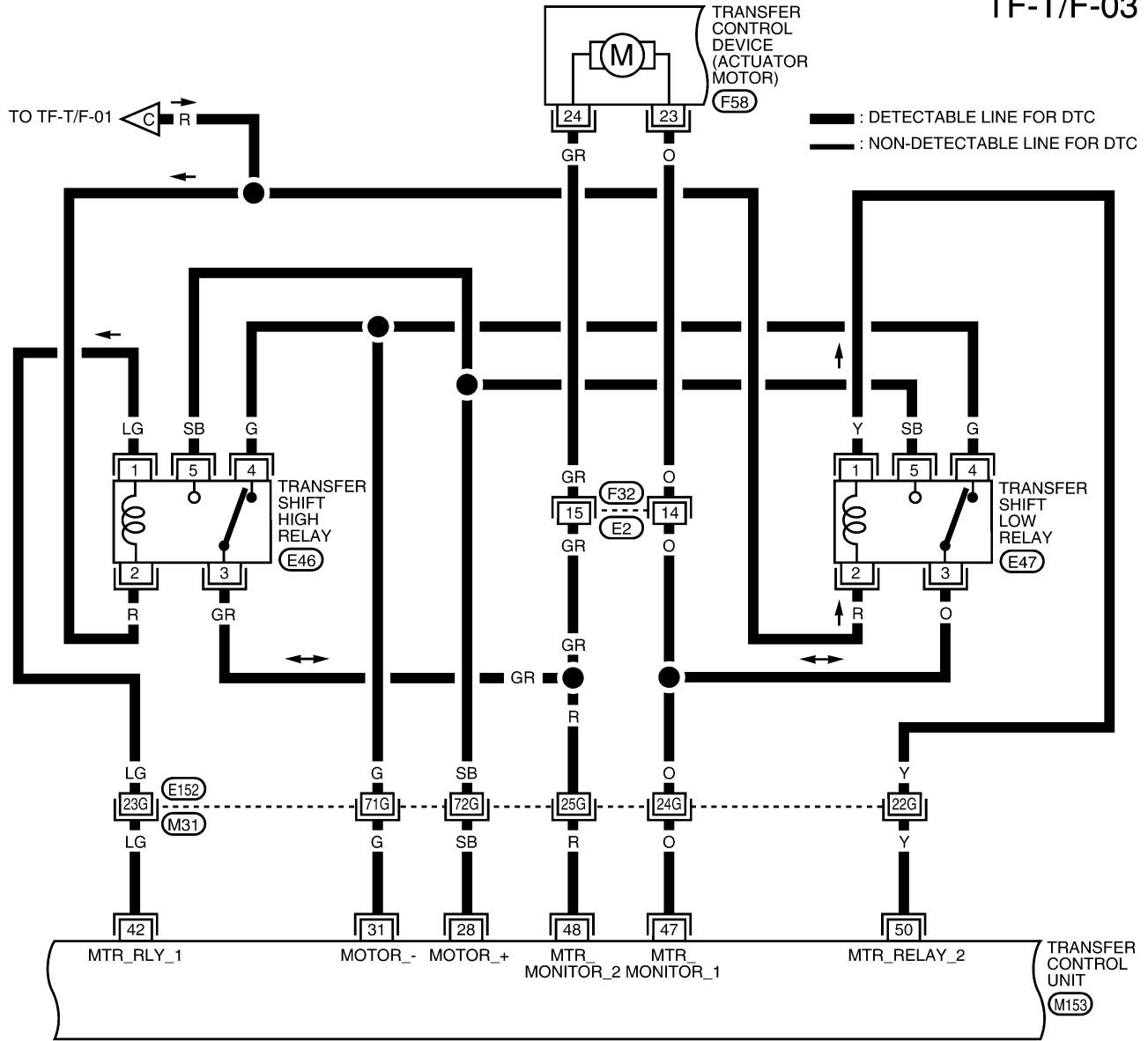

(M153)
W



(E46)
B

(E47)
B



(F32)
W



(F58)
B

REFER TO THE FOLLOWING.

(M31) - SUPER MULTIPLE JUNCTION (SMJ)

BDWA0137E

TROUBLE DIAGNOSIS

TF-T/F-04

: DETECTABLE LINE FOR DTC
 : NON-DETECTABLE LINE FOR DTC

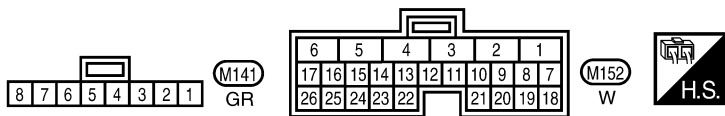
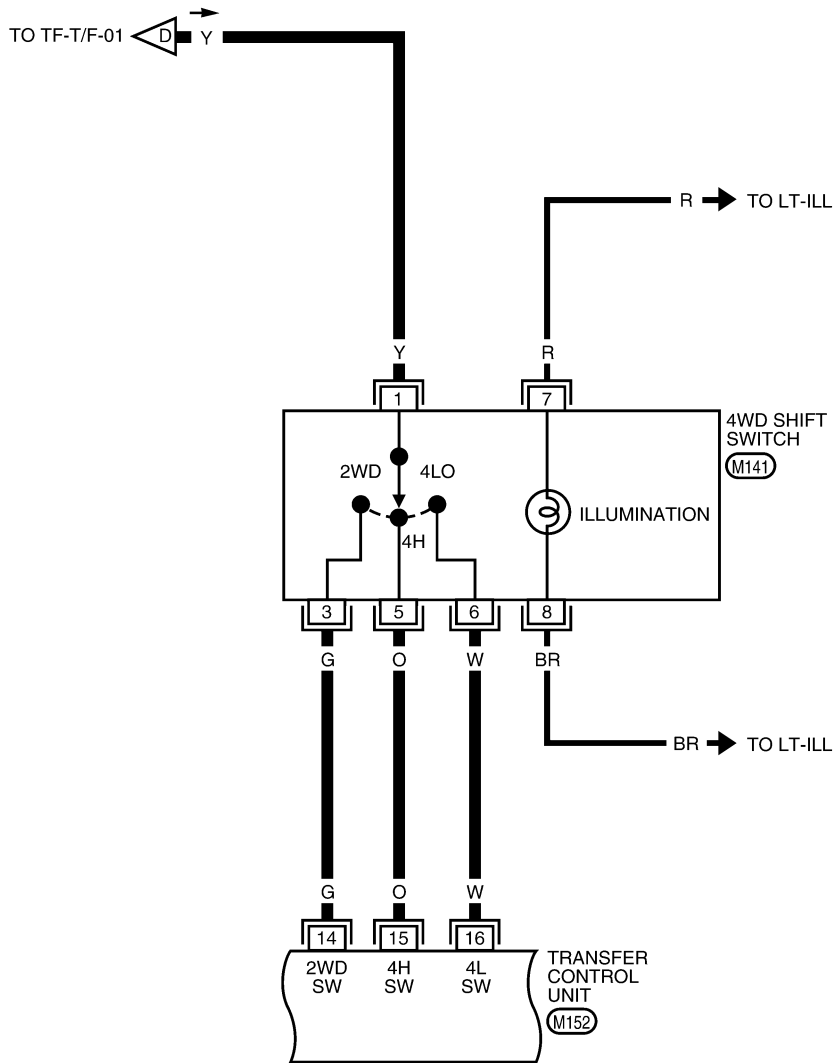

BDWA0042E

TROUBLE DIAGNOSIS

TF-T/F-05

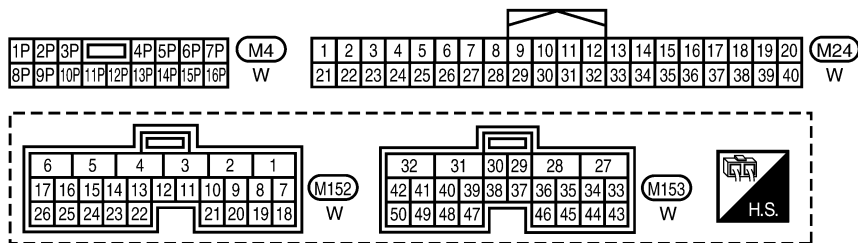
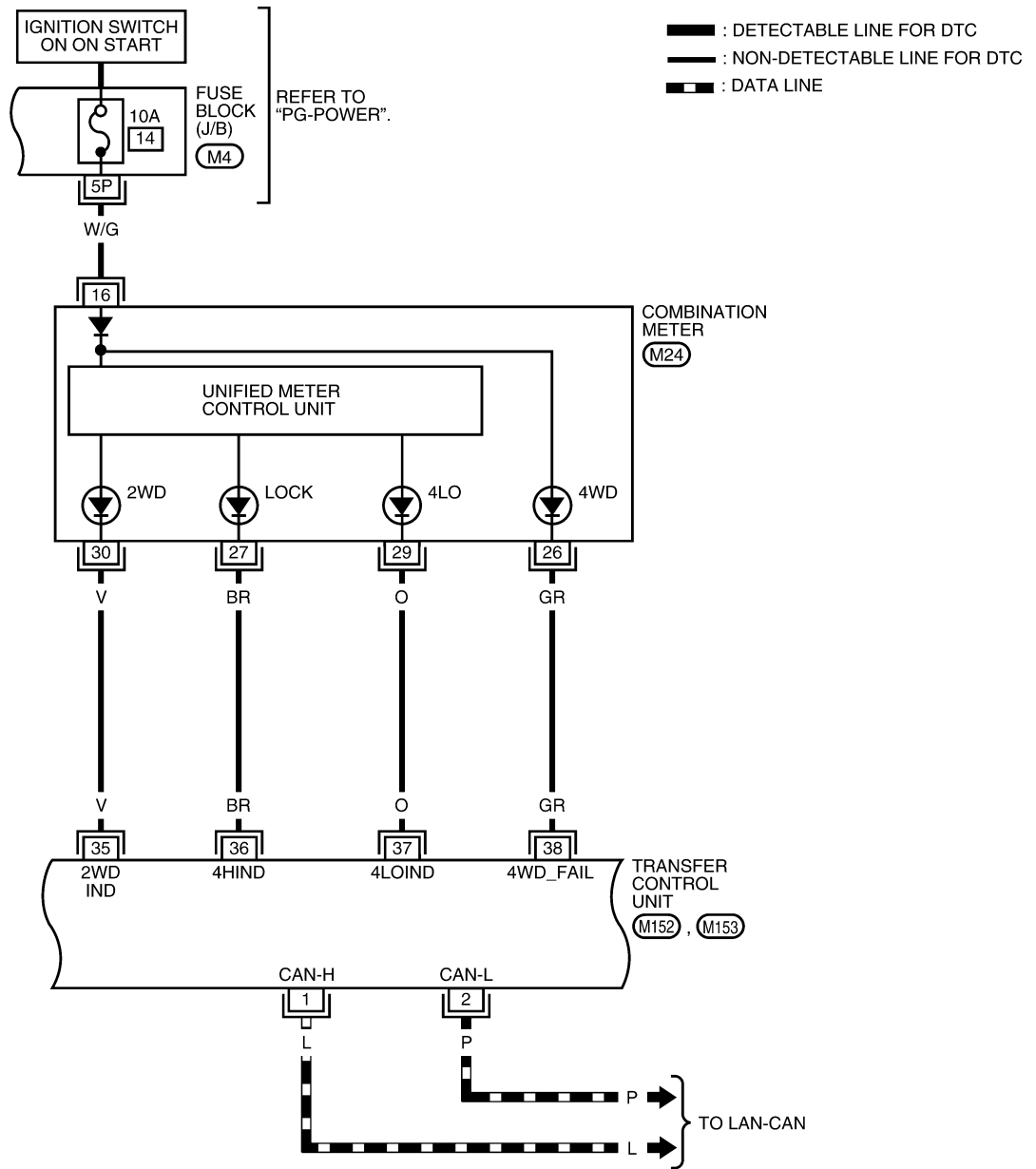

BDWA0138E

TROUBLE DIAGNOSIS

TF-T/F-06

: DETECTABLE LINE FOR DTC
 : NON-DETECTABLE LINE FOR DTC

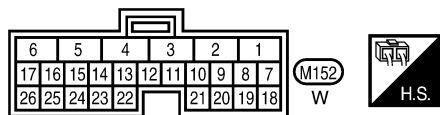
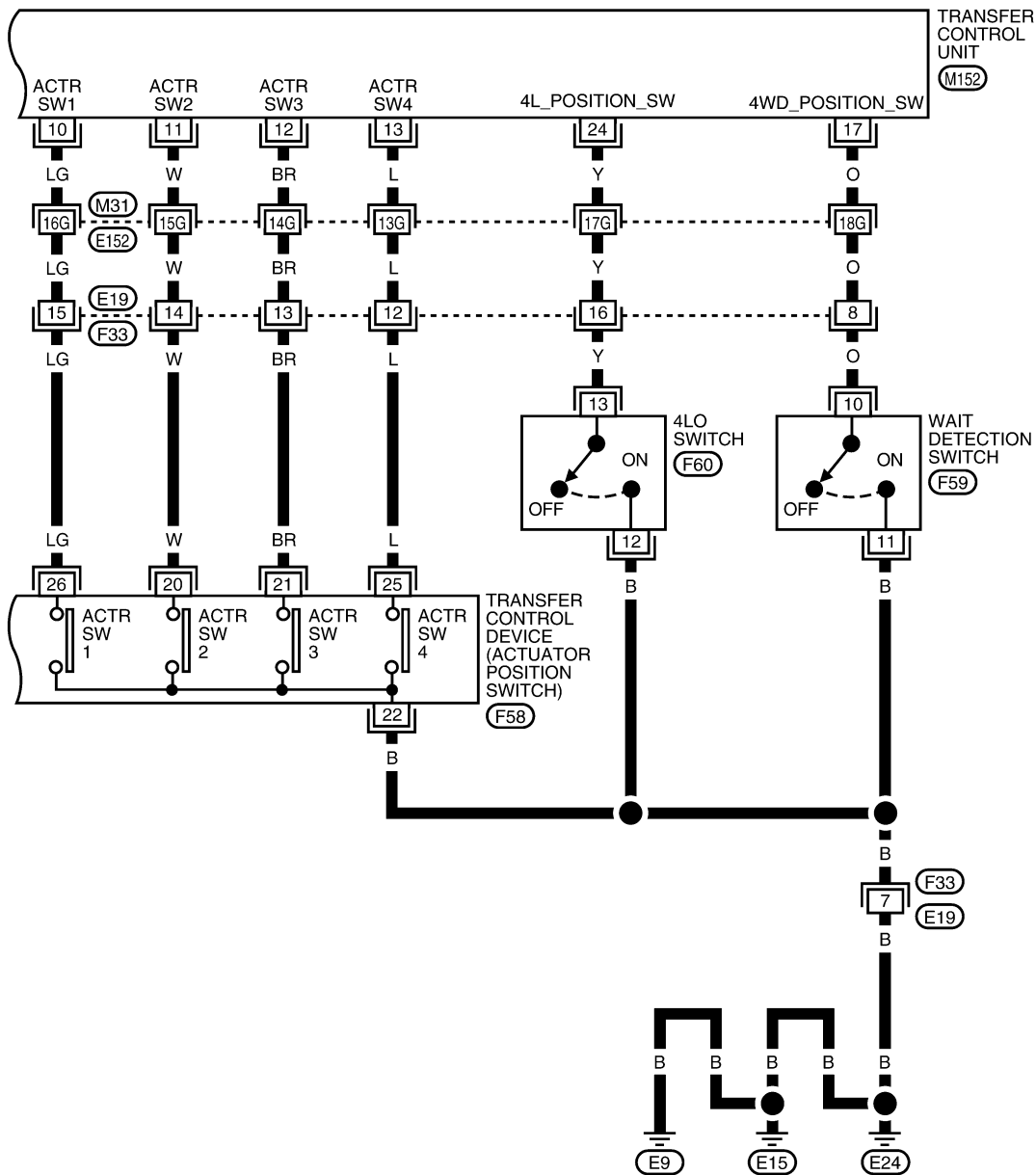

REFER TO THE FOLLOWING.

(M31) - SUPER MULTIPLE JUNCTION (SMJ)

BDWA0061E

TROUBLE DIAGNOSIS

Schematic — A/T MODELS —

EDS0032K

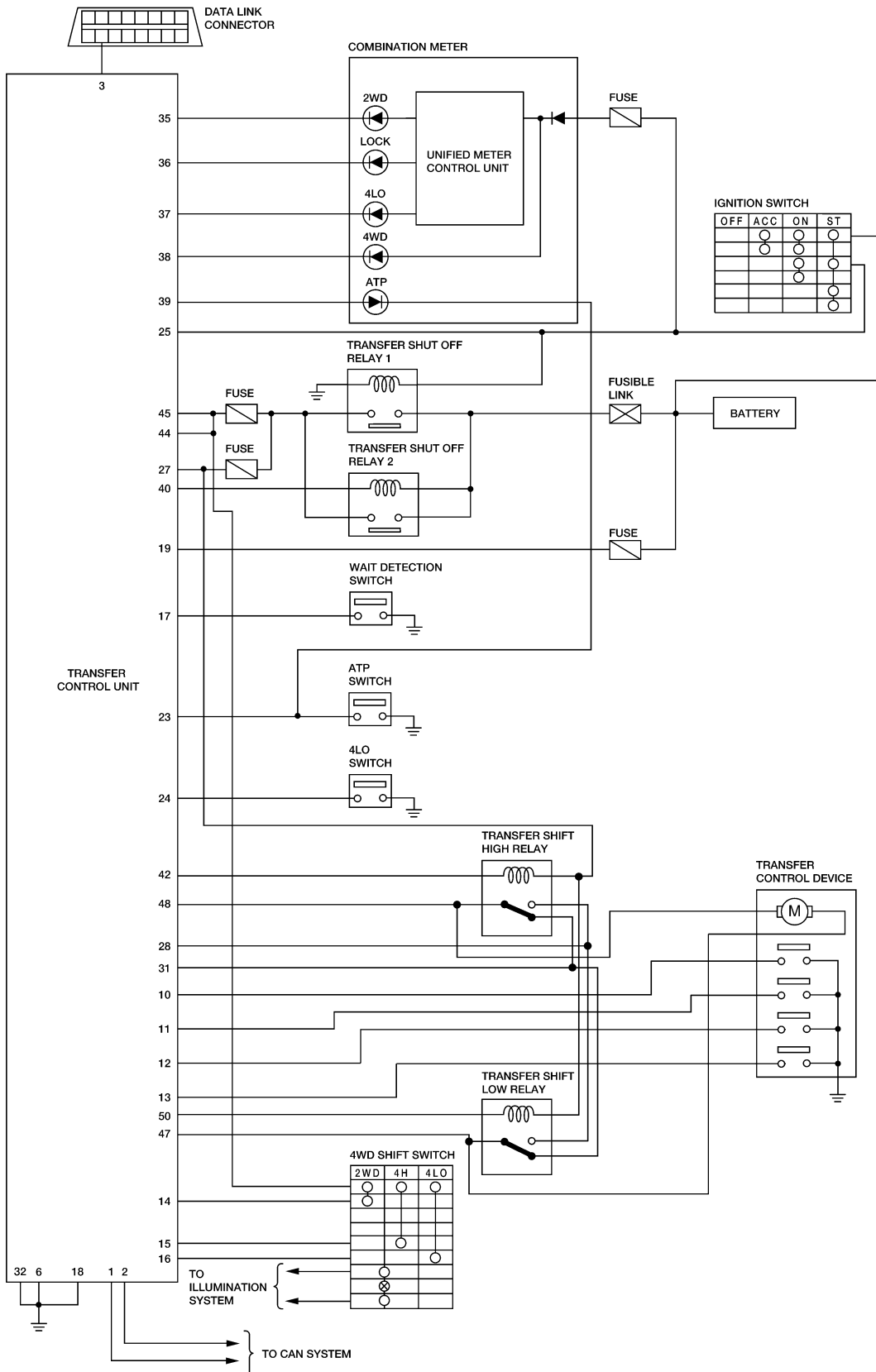

BDWA0139E

TROUBLE DIAGNOSIS

Wiring Diagram — T/F — A/T MODELS

EDS0032L

TF-T/F-07

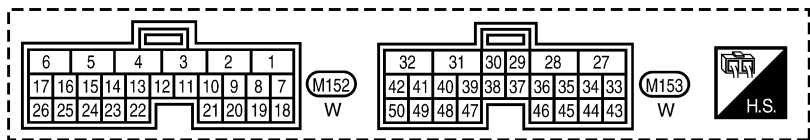
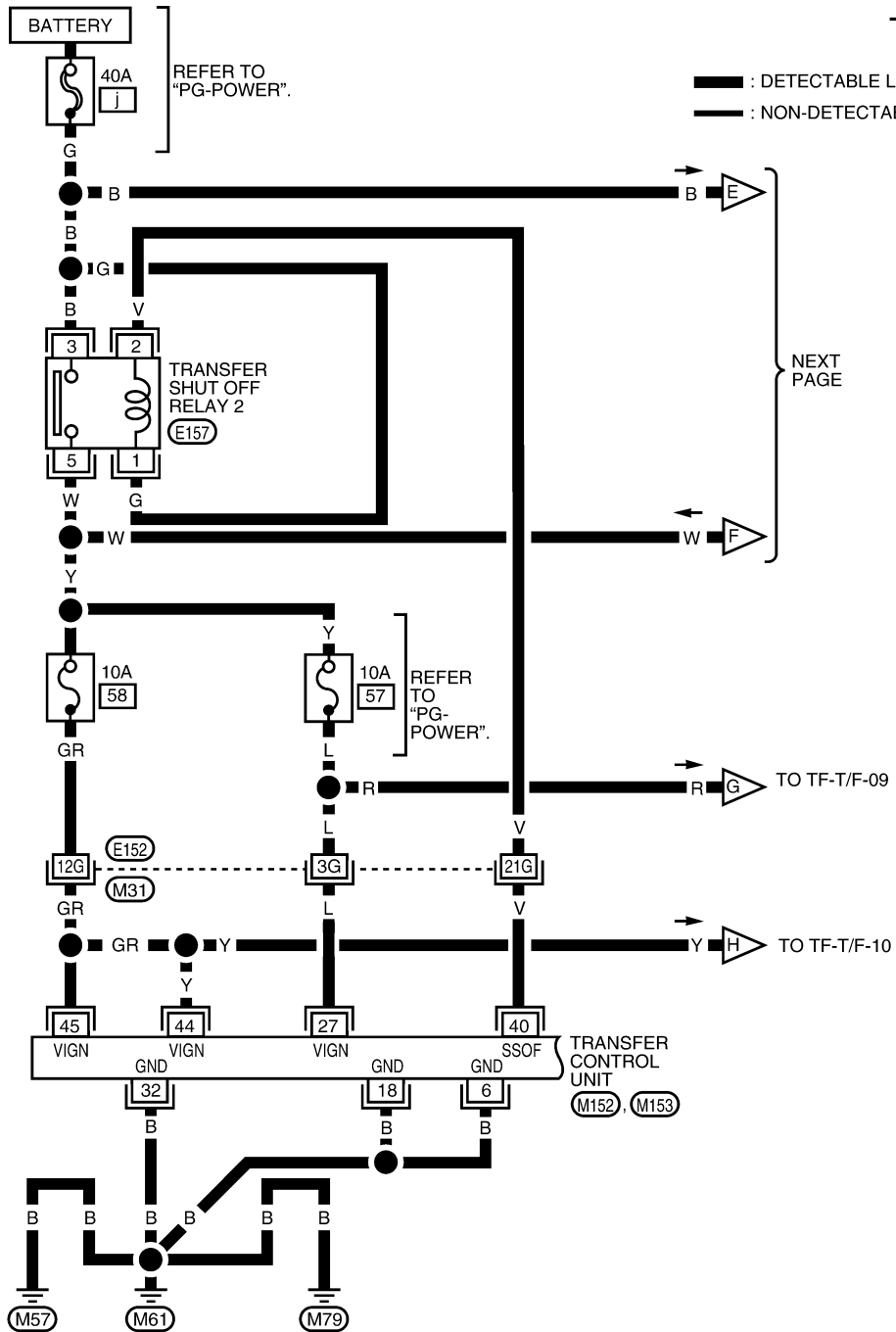

REFER TO THE FOLLOWING.
 (M31) - SUPER MULTIPLE JUNCTION (SMJ)

BDWA0046E

TROUBLE DIAGNOSIS

TF-T/F-08

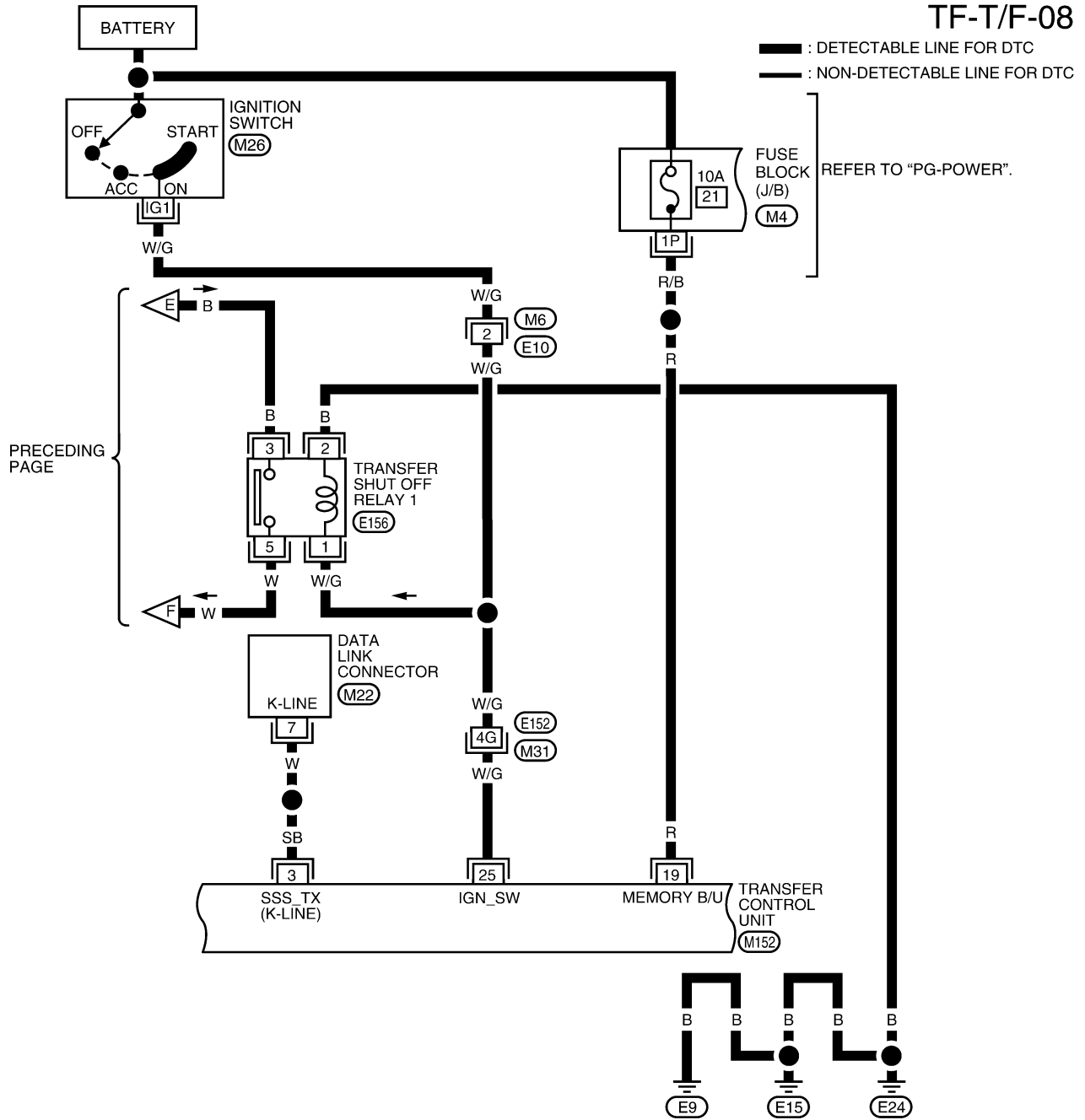

REFER TO THE FOLLOWING.

(M31) - SUPER MULTIPLE JUNCTION (SMJ)

M4: 16-pin terminal block with terminals 1P, 2P, 3P, 4P, 5P, 6P, 7P, 8P, 9P, 10P, 11P, 12P, 13P, 14P, 15P, 16P.

M6: 8-pin terminal block with terminals 1, 2, 3, 4, 5, 6, 7, 8.

M22: 16-pin terminal block with terminals 16, 15, 14, 13, 12, 11, 10, 9, 8, 7, 6, 5, 4, 3, 2, 1.

M26: 6-pin terminal block with terminals IG1, ST, B, IG2, ACC, R.

M152: 26-pin terminal block with terminals 6, 5, 4, 3, 2, 1, 17, 16, 15, 14, 13, 12, 11, 10, 9, 8, 7, 26, 25, 24, 23, 22, 21, 20, 19, 18.

E156: 3-pin terminal block with terminals 3, 5, 1.

TROUBLE DIAGNOSIS

TF-T/F-09

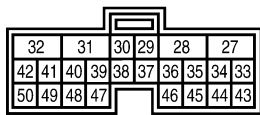
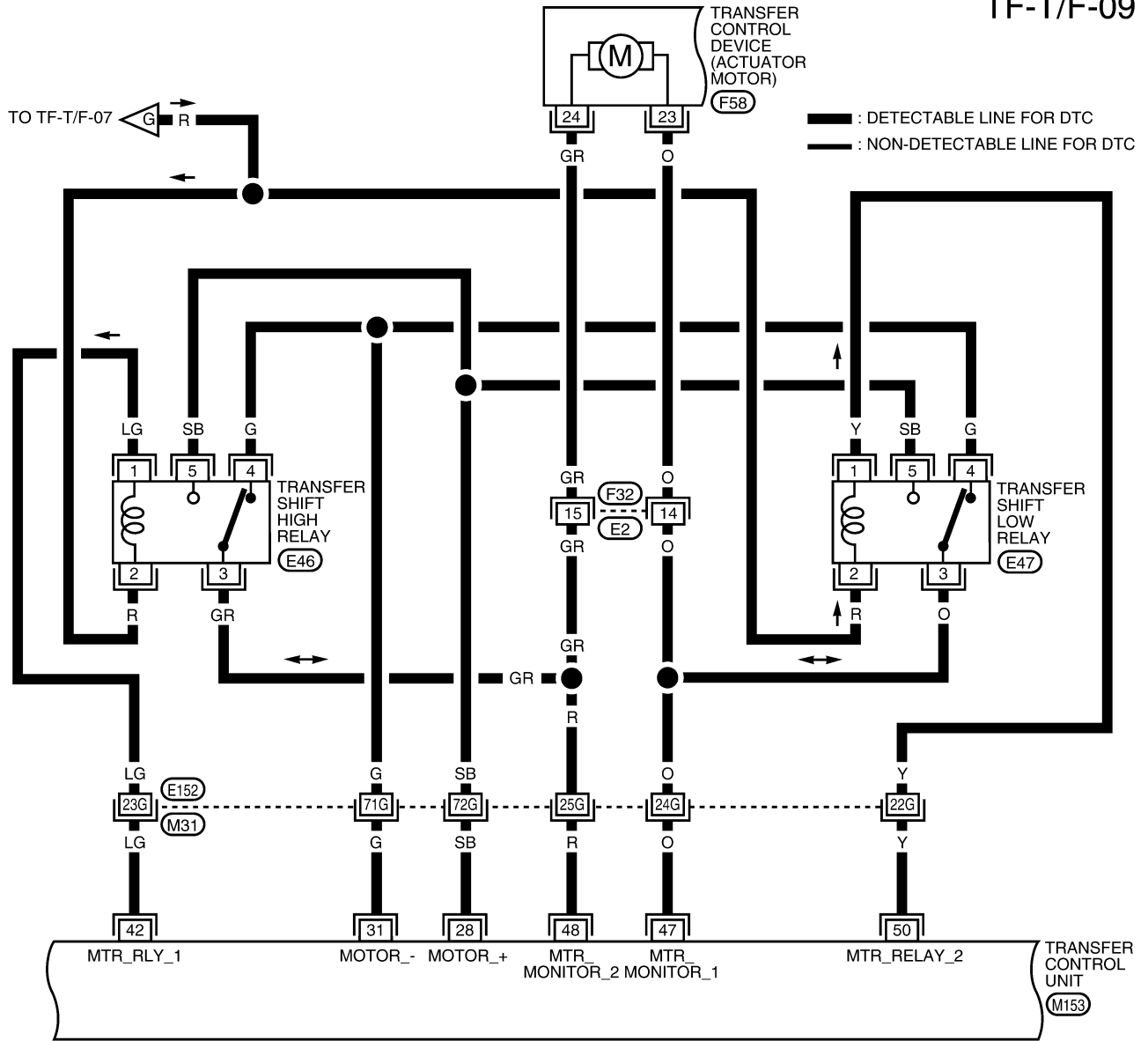

(M153)
W



(E46)
B

(E47)
B



(F32)
W



(F58)
B

REFER TO THE FOLLOWING.

(M31) - SUPER MULTIPLE JUNCTION (SMJ)

BDWA0141E

TROUBLE DIAGNOSIS

TF-T/F-10

— : DETECTABLE LINE FOR DTC
- - - : NON-DETECTABLE LINE FOR DTC

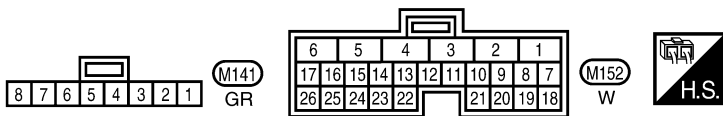
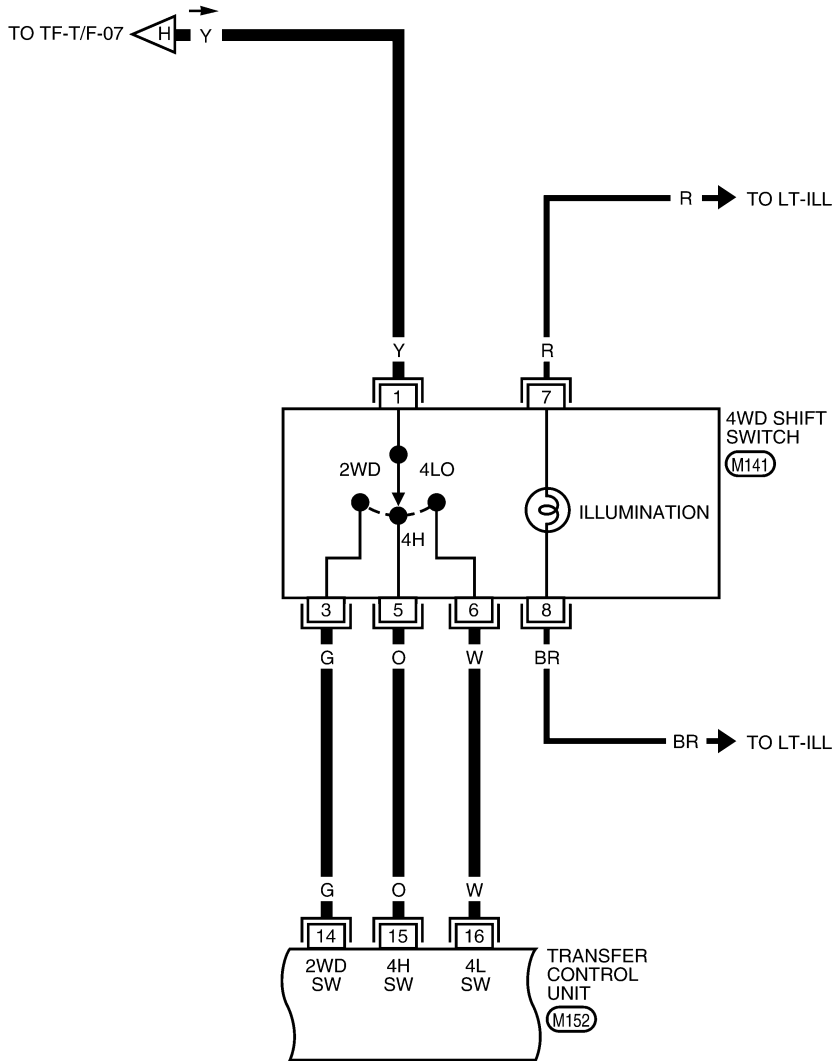

BDWA0049E

TROUBLE DIAGNOSIS

TF-T/F-11

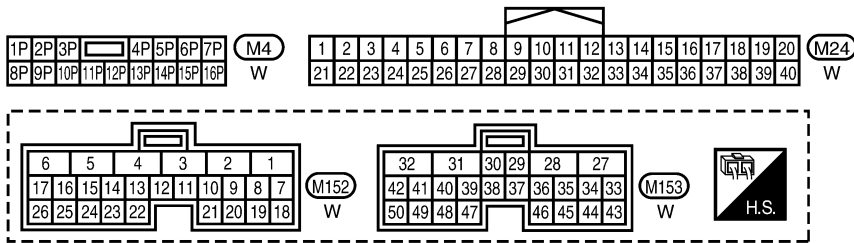
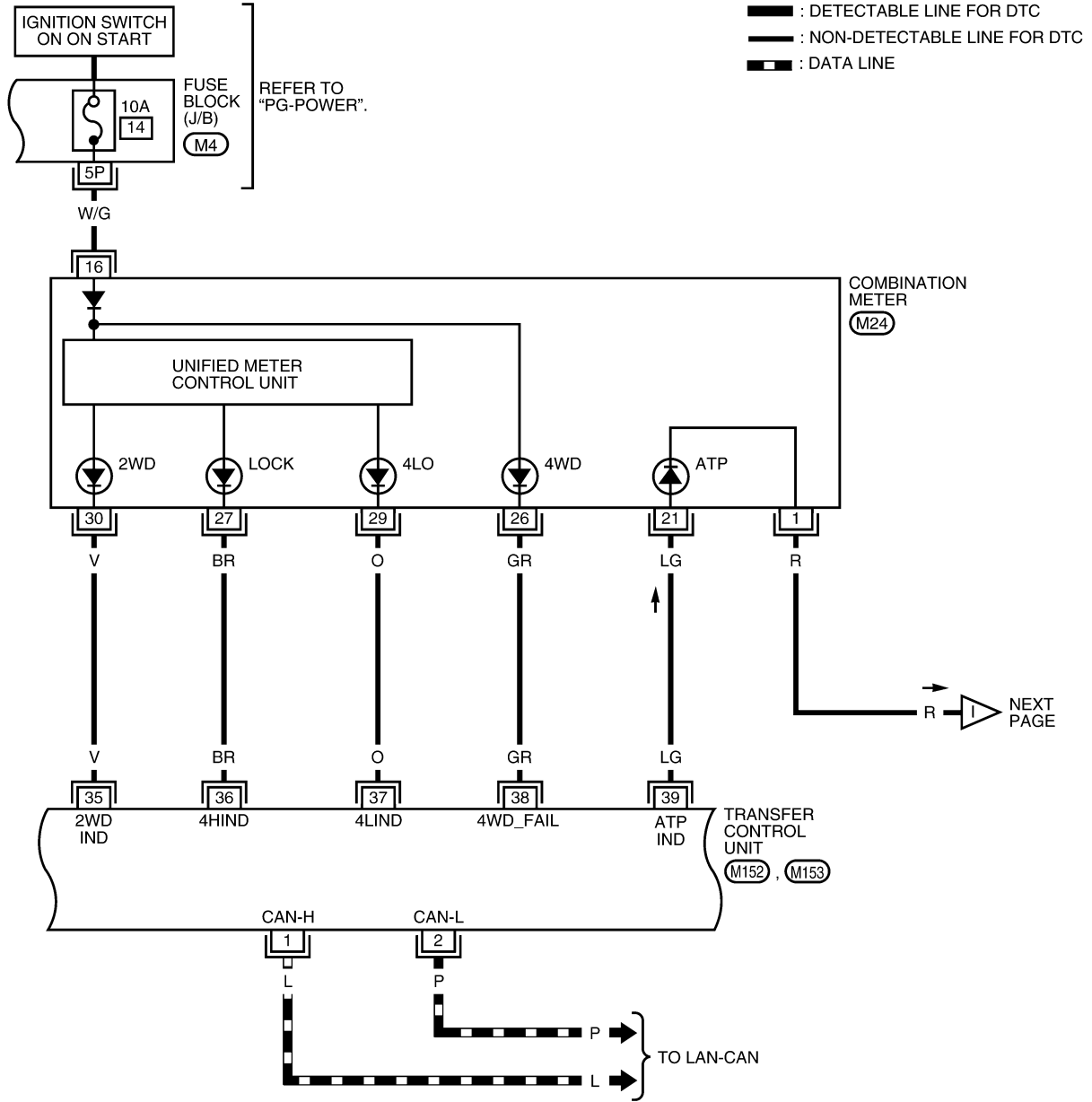

BDWA0142E

TROUBLE DIAGNOSIS

TF-T/F-12

: DETECTABLE LINE FOR DTC
 : NON-DETECTABLE LINE FOR DTC

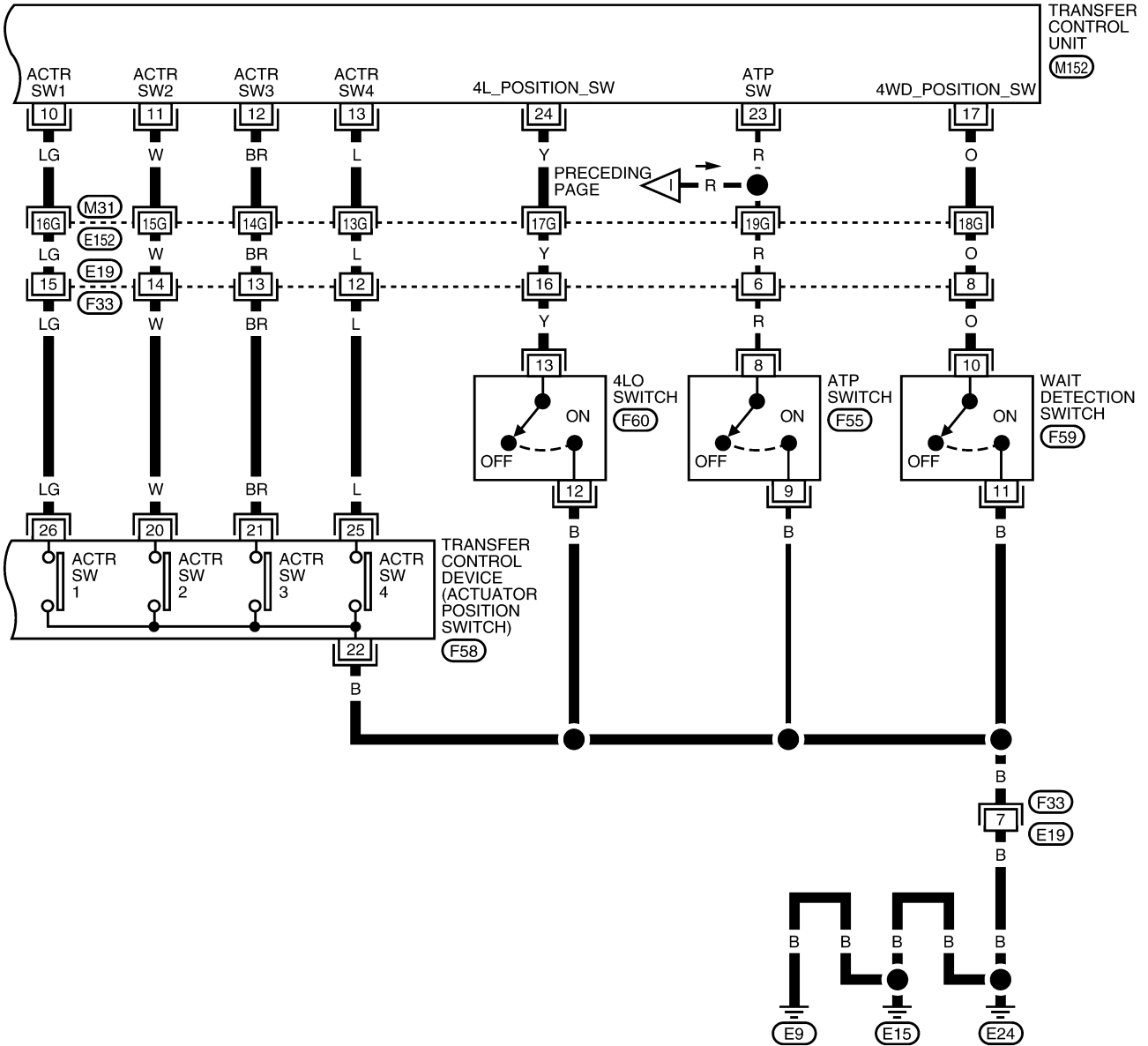

REFER TO THE FOLLOWING.

(M31) - SUPER MULTIPLE JUNCTION (SMJ)

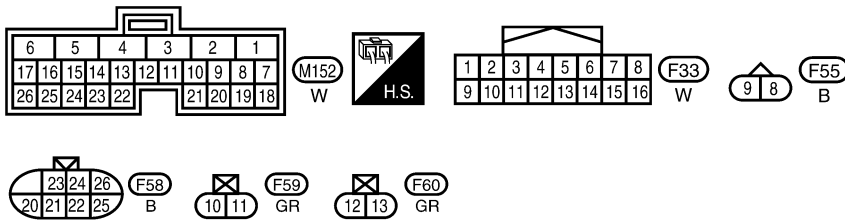

BDWA0065E

TROUBLE DIAGNOSIS

Trouble Diagnosis Chart for Symptoms

EDS002XQ

If 4WD warning lamp turns ON, perform self-diagnosis. Refer to [TF-47, "Self-Diagnostic Procedure"](#).

Symptom	Condition	Check item	Reference page
4WD shift indicator lamp and 4LO indicator lamp do not turn ON (4WD shift indicator lamp and 4LO indicator lamp check)	Ignition switch: ON	Power supply and ground for transfer control unit	TF-90
		Transfer shut off relay	
		Combination meter	
4WD warning lamp does not turn ON (4WD warning lamp check)	Ignition switch: ON	Power supply and ground for transfer control unit	TF-93
		Transfer shut off relay	
		Combination meter	
4WD shift indicator lamp or 4LO indicator lamp does not change	Engine running	4WD shift switch	TF-96
		Wait detection switch	
		4LO switch	
		ATP switch	
		Transfer inner parts	
ATP warning lamp does not turn ON	Engine running	CAN communication line	TF-98
		4WD shift switch	
		PNP switch signal	
		ATP switch	
		Combination meter	
		Transfer inner parts	
4WD shift indicator lamp repeats flashing	Engine running	Wait detection switch	TF-100
		4LO switch	
		Transfer inner parts	
4WD warning lamp flashes slowly Slow flashing: 1 time/2 seconds	While driving	Tire size is different between front and rear of vehicle.	TF-100

Transfer Control Unit Input/Output Signal Reference Values

EDS002XR

TRANSFER CONTROL UNIT INSPECTION TABLE

Specifications with CONSULT-II

Monitored item [Unit]	Content	Condition	Display value
VHCL/S SEN-FR [km/h] or [mph]	Wheel speed (Front wheel)	Vehicle stopped	0 km/h (0 mph)
		Vehicle running CAUTION: Check air pressure of tire under standard condition.	Approximately equal to the indication on speedometer (Inside of ±10%)
VHCL/S SEN-RR [km/h] or [mph]	Wheel speed (Rear wheel)	Vehicle stopped	0 km/h (0 mph)
		Vehicle running CAUTION: Check air pressure of tire under standard condition.	Approximately equal to the indication on speedometer (Inside of ±10%)
ENGINE SPEED [rpm]	Engine speed	Engine stopped (Engine speed: Less than 400 rpm)	0 rpm
		Engine running (Engine speed: 400 rpm or more)	Approximately equal to the indication on tachometer
BATTERY VOLT [V]	Power supply voltage for transfer control unit	Ignition switch: ON	Battery voltage

TROUBLE DIAGNOSIS

Monitored item [Unit]	Content	Condition	Display value	
2WD SWITCH [ON/OFF]	Input condition from 4WD shift switch	4WD shift switch: 2WD	ON	
		4WD shift switch: 4H and 4LO	OFF	
4H SWITCH [ON/OFF]	Input condition from 4WD shift switch	4WD shift switch: 4H	ON	
		4WD shift switch: 2WD and 4LO	OFF	
4L SWITCH [ON/OFF]	Input condition from 4WD shift switch	4WD shift switch: 4LO	ON	
		4WD shift switch: 2WD and 4H	OFF	
4L POSI SW [ON/OFF]	Condition of 4LO switch	<ul style="list-style-type: none"> ● Vehicle stopped ● Engine running ● For A/T models, A/T selector lever "N" position with brake pedal depressed. ● For M/T models, M/T shift lever neutral position with clutch and brake pedal depressed. 	4WD shift switch: 4LO	ON
		Except the above	OFF	
ATP SWITCH [ON/OFF]	Condition of ATP switch	<ul style="list-style-type: none"> ● Vehicle stopped ● Engine running ● For A/T models, A/T selector lever "N" position with brake pedal depressed. 	4WD shift switch : 4H to 4LO or 4LO to 4H (While actuator motor is operating.)	ON
		Except the above	OFF	
WAIT DETCT SW [ON/OFF]	Condition of wait detection switch	<ul style="list-style-type: none"> ● Vehicle stopped ● Engine running ● For A/T models, A/T selector lever "N" position with brake pedal depressed. ● For M/T models, M/T shift lever neutral position with clutch and brake pedal depressed. 	4WD shift switch : 4H and 4LO	ON
		4WD shift switch: 2WD	OFF	
4WD MODE [2H/4H/4L]	Control status of 4WD (Output condition of 4WD shift indicator lamp and 4LO indicator lamp)	4WD shift switch (Engine running)	2WD	2H
			4H	4H
			4LO	4L
VHCL/S COMP [km/h] or [mph]	Vehicle speed	Vehicle stopped	0 km/h (0 mph)	
		Vehicle running CAUTION: Check air pressure of tire under standard condition.	Approximately equal to the indication on speedometer (Inside of ±10%)	
SHIFT ACT 1 [ON/OFF]	Output condition to actuator motor (clockwise)	<ul style="list-style-type: none"> ● Vehicle stopped ● Engine running ● For A/T models, A/T selector lever "N" position with brake pedal depressed. ● For M/T models, M/T shift lever neutral position with clutch and brake pedal depressed. 	4WD shift switch : 2WD to 4H or 4H to 4LO or 2WD to 4LO	ON
		Except the above	OFF	

TROUBLE DIAGNOSIS

Monitored item [Unit]	Content	Condition	Display value	
SHIFT AC MON1 [ON/OFF]	Check signal for transfer control unit signal output	<ul style="list-style-type: none"> ● Vehicle stopped ● Engine running ● For A/T models, A/T selector lever "N" position with brake pedal depressed. 	4WD shift switch : 2WD to 4H or 4H to 4LO or 2WD to 4LO	ON
		<ul style="list-style-type: none"> ● For M/T models, M/T shift lever neutral position with clutch and brake pedal depressed. 	Except the above	OFF
SHIFT ACT 2 [ON/OFF]	Output condition to actuator motor (counterclockwise)	<ul style="list-style-type: none"> ● Vehicle stopped ● Engine running ● For A/T models, A/T selector lever "N" position with brake pedal depressed. 	4WD shift switch : 4LO to 4H or 4H to 2WD or 4LO to 2WD	ON
		<ul style="list-style-type: none"> ● For M/T models, M/T shift lever neutral position with clutch and brake pedal depressed. 	Except the above	OFF
SHIFT AC MON2 [ON/OFF]	Check signal for transfer control unit signal output	<ul style="list-style-type: none"> ● Vehicle stopped ● Engine running ● For A/T models, A/T selector lever "N" position with brake pedal depressed. 	4WD shift switch : 4LO to 4H or 4H to 2WD or 4LO to 2WD	ON
		<ul style="list-style-type: none"> ● For M/T models, M/T shift lever neutral position with clutch and brake pedal depressed. 	Except the above	OFF
SHIFT ACT/R MON [ON/OFF]	Operating condition of actuator motor relay (integrated in transfer control unit)	<ul style="list-style-type: none"> ● Vehicle stopped ● Engine running ● For A/T models, A/T selector lever "N" position with brake pedal depressed. 	When 4WD shift switch is operated	ON
		<ul style="list-style-type: none"> ● For M/T models, M/T shift lever neutral position with clutch and brake pedal depressed. 	When 4WD shift switch is not operated	OFF
SHIFT POS SW1 [ON/OFF]	Condition of actuator position switch 1	<ul style="list-style-type: none"> ● Vehicle stopped ● Engine running ● For A/T models, A/T selector lever "N" position with brake pedal depressed. ● For M/T models, M/T shift lever neutral position with clutch and brake pedal depressed. 	4WD shift switch: 2WD and 4LO	ON
SHIFT POS SW2 [ON/OFF]	Condition of actuator position switch 2		4WD shift switch: 4H	OFF
SHIFT POS SW3 [ON/OFF]	Condition of actuator position switch 3		4WD shift switch: 4LO	ON
			4WD shift switch: 2WD and 4H	OFF
SHIFT POS SW4 [ON/OFF]	Condition of actuator position switch 4		4WD shift switch: 2WD and 4H	ON
			4WD shift switch: 4LO	OFF
4WD FAIL LAMP [ON/OFF]	4WD warning lamp condition	4WD warning lamp: ON	ON	
		4WD warning lamp: OFF	OFF	

A
B
C
TF
E
F
G
H
I
J
K
L
M

TROUBLE DIAGNOSIS

Monitored item [Unit]	Content	Condition	Display value
2WD IND [ON/OFF]	Rear indicator of 4WD shift indicator lamp condition	Rear indicator of 4WD shift indicator lamp: ON	ON
		Rear indicator of 4WD shift indicator lamp: OFF	OFF
4H IND [ON/OFF]	Front and center indicator of 4WD shift indicator lamp condition	Front and center indicator of 4WD shift indicator lamp : ON	ON
		Front and center indicator of 4WD shift indicator lamp : OFF	OFF
4L IND [ON/OFF]	4LO indicator lamp condition	4LO indicator lamp: ON	ON
		4LO indicator lamp: OFF	OFF

Specifications Between Transfer Control Unit Terminals

TRANSFER CONTROL UNIT TERMINAL CONNECTOR LAYOUT

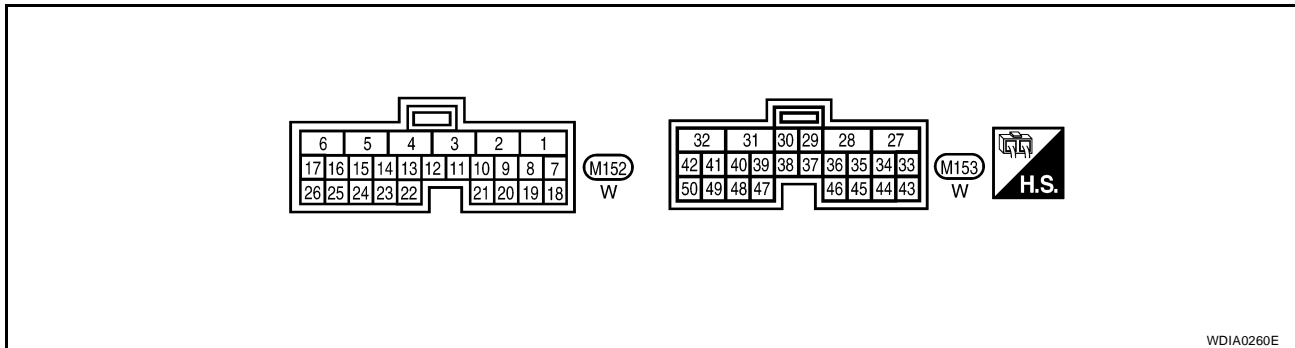

NOTE:

Data are reference value and are measured between each terminal and ground.

Terminal	Wire color	Item	Condition	Data (Approx.)
1	L	CAN-H	-	-
2	P	CAN-L	-	-
3	SB	K-LINE (CONSULT-II signal)	-	-
6	B	Ground	Always	0V
10	LG	Actuator position switch 1	<ul style="list-style-type: none"> Vehicle stopped 4WD shift switch: 2WD and 4LO	0V
11	W	Actuator position switch 2	<ul style="list-style-type: none"> Engine running 4WD shift switch: 4H	Battery voltage
			<ul style="list-style-type: none"> For A/T models, A/T selector lever "N" position with brake pedal depressed. 4WD shift switch: 4LO	0V
12	BR	Actuator position switch 3	<ul style="list-style-type: none"> For A/T models, A/T selector lever "N" position with brake pedal depressed. 4WD shift switch: 2WD and 4H	Battery voltage
			<ul style="list-style-type: none"> For M/T models, M/T shift lever neutral position with clutch and brake pedal depressed. 4WD shift switch: 2WD and 4H	0V
13	L	Actuator position switch 4	<ul style="list-style-type: none"> For M/T models, M/T shift lever neutral position with clutch and brake pedal depressed. 4WD shift switch: 4LO	Battery voltage
			<ul style="list-style-type: none"> For M/T models, M/T shift lever neutral position with clutch and brake pedal depressed. 4WD shift switch: 4H and 4LO	0V
14	G	4WD shift switch (2WD)	4WD shift switch: 2WD	Battery voltage
			4WD shift switch: 4H and 4LO	0V
15	O	4WD shift switch (4H)	Ignition switch: ON	Battery voltage
			4WD shift switch: 2WD and 4LO	0V
16	W	4WD shift switch (4LO)	4WD shift switch: 4LO	Battery voltage
			4WD shift switch: 2WD and 4H	0V

TROUBLE DIAGNOSIS

Terminal	Wire color	Item	Condition		Data (Approx.)
17	O	Wait detection switch	<ul style="list-style-type: none"> ● Vehicle stopped ● Engine running ● For A/T models, A/T selector lever "N" position with brake pedal depressed. ● For M/T models, M/T shift lever neutral position with clutch and brake pedal depressed. 	4WD shift switch: 4H and 4LO	0V
				4WD shift switch: 2WD	Battery voltage
18	B	Ground	Always		0V
19	R	Power supply (Memory back-up)	Always		Battery voltage
23	R	ATP switch (A/T models)	<ul style="list-style-type: none"> ● Vehicle stopped ● Engine running ● For A/T models, A/T selector lever "N" position with brake pedal depressed. 	4WD shift switch : 4H to 4LO or 4LO to 4H (While actuator motor is operating.)	0V
				Except the above	Battery voltage
24	Y	4LO switch	<ul style="list-style-type: none"> ● Vehicle stopped ● Engine running ● For A/T models, A/T selector lever "N" position with brake pedal depressed. ● For M/T models, M/T shift lever neutral position with clutch and brake pedal depressed. 	4WD shift switch: 4LO	0V
				Except the above	Battery voltage
25	W/G	Ignition switch monitor	Ignition switch: ON		Battery voltage
			Ignition switch: OFF		0V
27	L	Actuator motor power supply	Ignition switch: ON		Battery voltage
			Ignition switch: OFF (5 seconds after ignition switch is turned OFF)		0V
28	SB	Actuator motor (+)	<ul style="list-style-type: none"> ● Vehicle stopped ● Engine running ● For A/T models, A/T selector lever "N" position with brake pedal depressed. 	When 4WD shift switch is operated (while actuator motor is operating)	Battery voltage → 0V
				When 4WD shift switch is not operated	0V
31	G	Actuator motor (-)	<ul style="list-style-type: none"> ● For M/T models, M/T shift lever neutral position with clutch and brake pedal depressed. 	Always	0V
32	B	Ground	Always		0V

A

B

C

TF

E

F

G

H

I

J

K

L

M

TROUBLE DIAGNOSIS

Terminal	Wire color	Item	Condition		Data (Approx.)
33	P	Park/Neutral position switch (M/T models)	Ignition switch: ON	M/T shift lever neutral position	0V
				Except the above	Battery voltage
35	V	4WD shift indicator lamp (Rear indicator)	Engine running	Rear indicator of 4WD shift indicator lamp : ON	0V
				Rear indicator of 4WD shift indicator lamp : OFF	Battery voltage
36	BR	4WD shift indicator lamp (Front and center indicator)	Engine running	Front and center indicator of 4WD shift indicator lamp: ON	0V
				Front and center indicator of 4WD shift indicator lamp: OFF	Battery voltage
37	O	4LO indicator lamp	Engine running	4LO indicator lamp: ON	0V
				4LO indicator lamp: OFF	Battery voltage
38	GR	4WD warning lamp	Engine running	4WD warning lamp: ON	0V
				4WD warning lamp: OFF	Battery voltage
39	LG	ATP warning lamp	<ul style="list-style-type: none"> ● Vehicle stopped ● Engine running ● A/T selector lever "P" position ● Brake pedal depressed 	4WD shift switch: 4H to 4LO or 4LO to 4H (While actuator motor is operating.)	Battery voltage
				Except the above	0V
40	V	Transfer shut off relay	Ignition switch: ON	Ignition switch: ON	0V
				Ignition switch: OFF (5 seconds after ignition switch is turned OFF)	Battery voltage
42	LG	Transfer shift high relay	<ul style="list-style-type: none"> ● Vehicle stopped ● Engine running ● For A/T models, A/T selector lever "N" position with brake pedal depressed. ● For M/T models, M/T shift lever neutral position with clutch and brake pedal depressed. 	4WD shift switch: 2WD to 4H or 4H to 4LO or 2WD to 4LO	0V
				Except the above	Battery voltage
44	Y	Power supply	Ignition switch: ON	Ignition switch: ON	Battery voltage
				Ignition switch: OFF (5 seconds after ignition switch is turned OFF)	0V
45	GR	Power supply	Ignition switch: ON	Ignition switch: ON	Battery voltage
				Ignition switch: OFF (5 seconds after ignition switch is turned OFF)	0V

TROUBLE DIAGNOSIS

Terminal	Wire color	Item	Condition	Data (Approx.)	
47	O	Transfer shift high relay monitor	<ul style="list-style-type: none"> ● Vehicle stopped ● Engine running ● For A/T models, A/T selector lever "N" position with brake pedal depressed. 	4WD shift switch: 2WD to 4H or 4H to 4LO or 2WD to 4LO (while actuator motor is operating)	Battery voltage → 0V
				Except the above	0V
48	R	Transfer shift low relay monitor	<ul style="list-style-type: none"> ● For M/T models, M/T shift lever neutral position with clutch and brake pedal depressed. 	4WD shift switch: 4LO to 4H or 4H to 2WD or 4LO to 2WD (while actuator motor is operating)	Battery voltage → 0V
					Except the above
50	Y	Transfer shift low relay		4WD shift switch: 4LO to 4H or 4H to 2WD or 4LO to 2WD	0V
					Except the above

CAUTION:

When using a circuit tester to measure voltage for inspection, be sure not to extend forcibly any connector terminals.

A
B
C
TF
E
F
G
H
I
J
K
L
M

TROUBLE DIAGNOSIS

CONSULT-II Function (ALL MODE AWD/4WD) FUNCTION

EDS002XS

CONSULT-II can display each diagnostic item using the diagnostic test modes shown following.

ALL MODE AWD/4WD diagnostic mode	Description
SELF-DIAG RESULTS	Displays transfer control unit self-diagnosis results.
DATA MONITOR	Displays transfer control unit input/output data in real time.
CAN DIAG SUPPORT MNTR	The results of transmit/receive diagnosis of CAN communication can be read.
ECU PART NUMBER	Transfer control unit part number can be read.

CONSULT-II SETTING PROCEDURE

CAUTION:

If CONSULT-II is used with no connection of CONSULT-II CONVERTER, malfunctions might be detected in self-diagnosis depending on control unit which carries out CAN communication.

NOTE:

For details, refer to the separate "CONSULT-II Operations Manual".

1. Turn ignition switch "OFF".
2. Connect CONSULT-II and CONSULT-II CONVERTER to data link connector on vehicle.
3. Turn ignition switch "ON".

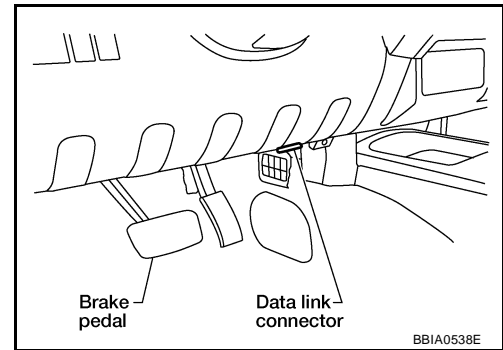

4. Touch "START (NISSAN BASED VHCL)".

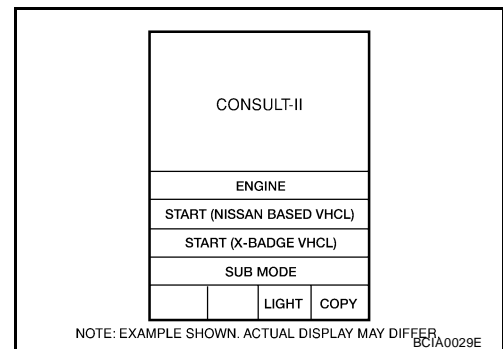

5. Touch "ALL MODE AWD/4WD".
If "ALL MODE AWD/4WD" is not indicated, go to [GI-41, "CONSULT-II Data Link Connector \(DLC\) Circuit"](#).
6. Perform each diagnostic test mode according to each service procedure.

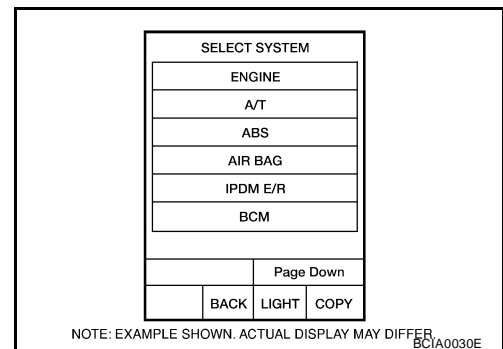

TROUBLE DIAGNOSIS

SELF-DIAG RESULT MODE

Operation Procedure

1. Perform "CONSULT-II SETTING PROCEDURE". Refer to [TF-44, "CONSULT-II SETTING PROCEDURE"](#).
2. With engine at idle, touch "SELF-DIAG RESULTS".
Display shows malfunction experienced since the last erasing operation.

NOTE:

The details for "TIME" are as follows:

- "0": Error currently detected with transfer control unit.
- Except for "0": Error detected in the past and memorized with transfer control unit.
Detects frequency of driving after DTC occurs (frequency of turning ignition switch "ON/OFF").

SELF-DIAG RESULTS	
DTC RESULTS	TIME
CAN COMM CIRCUIT [U1000]	0
SHIFT ACT POSI SW [P1818]	1
ERASE	PRINT

SDIA2687E

Display Item List

Items (CONSULT-II screen terms)	Diagnostic item is detected when...	Check item
INITIAL START [P1801]	Due to removal of battery which cuts off power supply to transfer control unit, self-diagnosis memory function is suspended.	TF-51, "Power Supply Circuit For Transfer Control Unit"
CONTROL UNIT 1 [P1802]	Malfunction is detected in the memory (RAM) system of transfer control unit.	TF-54, "Transfer Control Unit"
CONTROL UNIT 2 [P1803]	Malfunction is detected in the memory (ROM) system of transfer control unit.	TF-54, "Transfer Control Unit"
CONTROL UNIT 3 [P1804]	Malfunction is detected in the memory (EEPROM) system of transfer control unit.	TF-54, "Transfer Control Unit"
VHCL SPEED SEN-AT [P1807]	<ul style="list-style-type: none"> ● Malfunction is detected in output shaft revolution signal that is output from TCM through CAN communication. ● Improper signal is input while driving. 	TF-54, "Output Shaft Revolution Signal (TCM)"
VHCL SPEED SEN-ABS [P1808]	<ul style="list-style-type: none"> ● Malfunction is detected in vehicle speed signal that is output from ABS actuator and electric unit (control unit) through CAN communication. ● Improper signal is input while driving. 	TF-55, "Vehicle Speed Sensor (ABS)"
CONTROL UNIT 4 [P1809]	AD converter system of transfer control unit is malfunctioning.	TF-54, "Transfer Control Unit"
4L POSI SW TF [P1810]	Improper signal from 4LO switch is input due to open or short circuit.	TF-56, "4LO Switch"
BATTERY VOLTAGE [P1811]	Power supply voltage for transfer control unit is abnormally low while driving.	TF-51, "Power Supply Circuit For Transfer Control Unit"
4WD MODE SW [P1813]	More than two switch inputs are simultaneously detected due to short circuit of 4WD shift switch.	TF-59, "4WD Shift Switch"
4WD DETECT SWITCH [P1814]	Improper signal from wait detection switch is input due to open or short circuit.	TF-63, "Wait Detection Switch"
PNP SW/CIRC [P1816]	When A/T PNP switch signal is malfunctioning or communication error between control units.	TF-87, "Park/Neutral Position Switch (M/T Models)"
SHIFT ACTUATOR [P1817]	<ul style="list-style-type: none"> ● Motor does not operate properly due to open or short circuit in actuator motor. ● Malfunction is detected in the actuator motor. (When 4WD shift switch is operated and actuator motor is not operated) ● Malfunction is detected in transfer shift high relay or transfer shift low relay. 	TF-68, "Actuator Motor"
SHIFT ACT POSI SW [P1818]	<ul style="list-style-type: none"> ● Improper signal from actuator position switch is input due to open or short circuit. ● Malfunction is detected in actuator position switch. 	TF-77, "Actuator Position Switch"

TROUBLE DIAGNOSIS

Items (CONSULT-II screen terms)	Diagnostic item is detected when...	Check item
SHIFT ACT CIR [P1819]	<ul style="list-style-type: none"> ● Malfunction is detected in transfer shut off relay 1 and transfer shut off relay 2. ● Malfunction occurs in transfer control device drive circuit. 	TF-51, "Power Supply Circuit For Transfer Control Unit" , TF-80, "Transfer Control Device"
ENGINE SPEED SIG [P1820]	<ul style="list-style-type: none"> ● Malfunction is detected in engine speed signal that is output from ECM through CAN communication. ● Improper signal is input while driving. 	TF-83, "Engine Speed Signal"
CAN COMM CIRCUIT [U1000]	Malfunction has been detected from CAN communication line.	TF-84, "CAN Communication Line"
NO DTC IS DETECTED. FURTHER TESTING MAY BE REQUIRED.	No NG item has been detected.	—

CAUTION:

If "CAN COMM CIRCUIT [U1000]" is displayed with other DTCs, first perform the trouble diagnosis for CAN communication line.

NOTE:

If "SHIFT ACT POSI SW [P1818]" or "SHIFT ACT CIR [P1819]" is displayed, first erase self-diagnostic results. ("SHIFT ACT POSI SW [P1818]" or "SHIFT ACT CIR [P1819]" may be displayed after installing transfer control unit or transfer assembly.)

How to Erase Self-diagnostic Results

1. Perform applicable inspection of malfunctioning item and then repair or replace.
2. Start engine and select "SELF-DIAG RESULTS" mode for "ALL MODE AWD/4WD" with CONSULT-II.
3. Touch "ERASE" on CONSULT-II screen to erase DTC memory.

CAUTION:

If memory cannot be erased, perform applicable diagnosis.

DATA MONITOR MODE

Operation Procedure

1. Perform "CONSULT-II SETTING PROCEDURE". Refer to [TF-44, "CONSULT-II SETTING PROCEDURE"](#).
2. Touch "DATA MONITOR".
3. Select from "SELECT MONITOR ITEM", screen of data monitor mode is displayed.

NOTE:

When malfunction is detected, CONSULT-II performs REAL-TIME DIAGNOSIS. Also, any malfunction detected while in this mode will be displayed at real time.

Display Item List

×: Standard –: Not applicable

Monitored item (Unit)	Monitor item selection			Remarks
	ECU INPUT SIGNALS	MAIN SIGNALS	SELECTION FROM MENU	
VHCL/S SEN-FR [km/h] or [mph]	×	–	×	Wheel speed calculated by ABS actuator and electric unit (control unit). Signal input with CAN communication line.
VHCL/S SEN-RR [km/h] or [mph]	×	–	×	Wheel speed calculated by TCM. Signal input with CAN communication line.
ENGINE SPEED [rpm]	×	–	×	Engine speed is displayed. Signal input with CAN communication line.
BATTERY VOLT [V]	×	–	×	Power supply voltage for transfer control unit.
2WD SWITCH [ON/OFF]	×	–	×	4WD shift switch signal status is displayed.
4H SWITCH [ON/OFF]	×	–	×	
4L SWITCH [ON/OFF]	×	–	×	
4L POSI SW [ON/OFF]	×	–	×	4LO switch signal status is displayed.

TROUBLE DIAGNOSIS

Monitored item (Unit)	Monitor item selection			Remarks
	ECU INPUT SIGNALS	MAIN SIGNALS	SELECTION FROM MENU	
ATP SWITCH [ON/OFF]	×	–	×	ATP switch signal status is displayed. (A/T models)
WAIT DETCT SW [ON/OFF]	×	–	×	Wait detection switch signal status is displayed.
4WD MODE [2H/4H/4L]	–	×	×	Control status of 4WD recognized by transfer control unit. (2WD, 4H or 4LO)
VHCL/S COMP [km/h] or [mph]	–	×	×	Vehicle speed recognized by transfer control unit.
SHIFT ACT 1 [ON/OFF]	–	×	×	Output condition to actuator motor (clockwise)
SHIFT AC MON 1 [ON/OFF]	–	–	×	Check signal for transfer control unit signal output
SHIFT ACT 2 [ON/OFF]	–	×	×	Output condition to actuator motor (counterclockwise)
SHIFT AC MON 2 [ON/OFF]	–	–	×	Check signal for transfer control unit signal output
SFT ACT/R MON [ON/OFF]	–	–	×	Operating condition of actuator motor relay (integrated in transfer control unit)
SHIFT POS SW 1 [ON/OFF]	×	–	×	Condition of actuator position switch 1
SHIFT POS SW 2 [ON/OFF]	×	–	×	Condition of actuator position switch 2
SHIFT POS SW 3 [ON/OFF]	×	–	×	Condition of actuator position switch 3
SHIFT POS SW 4 [ON/OFF]	×	–	×	Condition of actuator position switch 4
4WD FAIL LAMP [ON/OFF]	–	×	×	Control status of 4WD warning lamp is displayed.
2WD IND [ON/OFF]	–	–	×	Control status of 4WD shift indicator lamp (rear) is displayed.
4H IND [ON/OFF]	–	–	×	Control status of 4WD shift indicator lamp (front and center) is displayed.
4L IND [ON/OFF]	–	–	×	Control status of 4LO indicator lamp is displayed.
Voltage [V]	–	–	×	The value measured by the voltage probe is displayed.
Frequency [Hz]	–	–	×	The value measured by the pulse probe is displayed.
DUTY-HI (high) [%]	–	–	×	
DUTY-LOW (low) [%]	–	–	×	
PLS WIDTH-HI [msec]	–	–	×	
PLS WIDTH-LOW [msec]	–	–	×	

Self-Diagnostic Procedure

EDS002XT

④ SELF-DIAGNOSTIC PROCEDURE (WITH CONSULT-II)

Refer to [TF-45, "SELF-DIAG RESULT MODE"](#) .

⊗ SELF-DIAGNOSTIC PROCEDURE (WITHOUT CONSULT-II)

Description

If the engine starts when there is something wrong with the 4WD system, the 4WD warning lamp turns ON or flickers in the combination meter. When the system functions properly, the warning lamp turns ON when the ignition switch is turned to "ON", and it turns OFF after engine starts. To locate the cause of a problem, start the self-diagnosis function. The 4WD warning lamp in the combination meter will indicate the problem area by flickering according to the self-diagnostic results. As for the details of the 4WD warning lamp flickering patterns, refer to [TF-48, "Judgement Self-diagnosis"](#) .

TROUBLE DIAGNOSIS

Diagnostic Procedure (A/T models)

1. Warm up engine.
2. Turn ignition switch "ON" and "OFF" at least twice, and then turn ignition switch "OFF".
3. Move A/T selector lever to "P" position.
4. Turn 4WD shift switch to "2WD" position.
5. Turn ignition switch "ON". (Do not start engine.)
6. 4WD warning lamp should turn ON.
If 4WD warning lamp does not turn ON, refer to [TF-93, "4WD Warning Lamp Does Not Turn ON"](#) .
7. Move A/T selector lever to "R" position.
8. Turn 4WD shift switch to "2WD", "4H" and "2WD" in order.
9. Move A/T selector lever to "P" position.
10. Turn 4WD shift switch to "4H", "2WD" and "4H" in order.
11. Move A/T selector lever to "N" position.
12. Turn 4WD shift switch to "2WD" position.
13. Move A/T selector lever to "P" position.
14. Read the flickering of 4WD warning lamp.
Refer to [TF-48, "Judgement Self-diagnosis"](#) .

Diagnostic Procedure (M/T models)

1. Warm up engine.
2. Turn ignition switch "ON" and "OFF" at least twice, and then turn ignition switch "OFF".
3. Move M/T shift lever to neutral position.
4. Turn 4WD shift switch to "2WD" position.
5. Turn ignition switch "ON". (Do not start engine.)
6. 4WD warning lamp should turn ON.
If 4WD warning lamp does not turn ON, refer to [TF-93, "4WD Warning Lamp Does Not Turn ON"](#) .
7. Move M/T shift lever to any position other than neutral.
8. Turn 4WD shift switch to "2WD", "4H" and "2WD" in order.
9. Move M/T shift lever to neutral position.
10. Turn 4WD shift switch to "4H", "2WD" and "4H" in order.
11. Move M/T shift lever to any position other than neutral.
12. Turn 4WD shift switch to "2WD" position.
13. Move M/T shift lever to neutral position.
14. Read the flickering of 4WD warning lamp.
Refer to [TF-48, "Judgement Self-diagnosis"](#) .

Judgement Self-diagnosis

When a malfunction is detected, the malfunction route is indicated by flickering of the 4WD warning lamp.

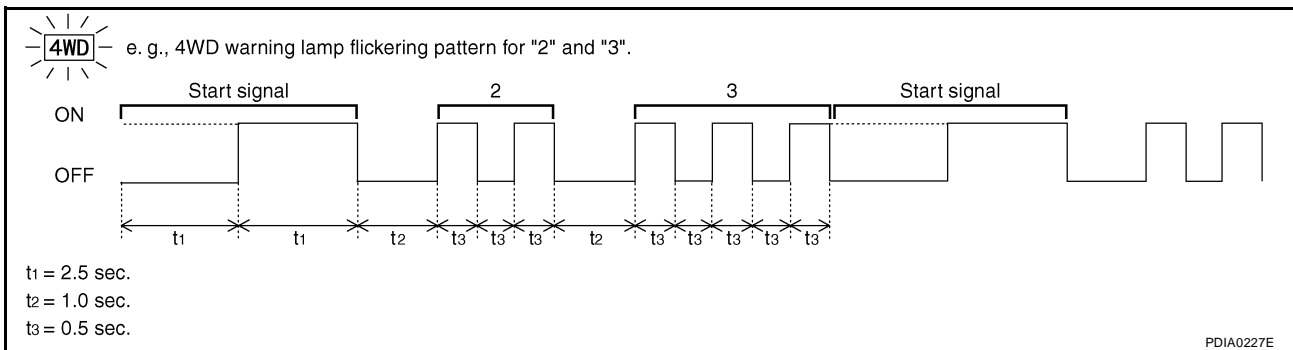

TROUBLE DIAGNOSIS

Flickering pattern or flickering condition	Items	Diagnostic item is detected when...	Check item	
2	Output shaft revolution signal (from TCM)	<ul style="list-style-type: none"> ● Malfunction is detected in output shaft revolution signal that is output from TCM through CAN communication. ● Improper signal is input while driving. 	TF-54, "Output Shaft Revolution Signal (TCM)"	A
3	Vehicle speed signal (from ABS)	<ul style="list-style-type: none"> ● Malfunction is detected in vehicle speed signal that is output from ABS actuator and electric unit (control unit) through CAN communication. ● Improper signal is input while driving. 	TF-55, "Vehicle Speed Sensor (ABS)"	B C
4	CAN communication	Malfunction has been detected from CAN communication.	TF-84, "CAN Communication Line"	TF
5	AD converter	AD converter system of transfer control unit is malfunctioning.	TF-54, "Transfer Control Unit"	
6	4LO switch	Improper signal from 4LO switch is input due to open or short circuit.	TF-56, "4LO Switch"	E
7	Engine speed signal	<ul style="list-style-type: none"> ● Malfunction is detected in engine speed signal that is output from ECM through CAN communication. ● Improper signal is input while driving. 	TF-83, "Engine Speed Signal"	F
8	Power supply	Power supply voltage for transfer control unit is abnormally low while driving.	TF-51, "Power Supply Circuit For Transfer Control Unit"	G
9	4WD shift switch	More than two switch inputs are simultaneously detected due to short circuit of 4WD shift switch.	TF-59, "4WD Shift Switch"	H
10	Wait detection switch	Improper signal from wait detection switch is input due to open or short circuit.	TF-63, "Wait Detection Switch"	I
11	Actuator motor	<ul style="list-style-type: none"> ● Motor does not operate properly due to open or short circuit in actuator motor. ● Malfunction is detected in the actuator motor. (When 4WD shift switch is operated and actuator motor is not operated) ● Malfunction is detected in transfer shift high relay or transfer shift low relay. 	TF-68, "Actuator Motor"	J
12	Actuator position switch	<ul style="list-style-type: none"> ● Improper signal from actuator position switch is input due to open or short circuit. ● Malfunction is detected in the actuator position switch. 	TF-77, "Actuator Position Switch"	K
13	Transfer control device	<ul style="list-style-type: none"> ● Malfunction is detected in transfer shut off relay 1 and transfer shut off 2. ● Malfunction occurs in transfer control device drive circuit. 	TF-51, "Power Supply Circuit For Transfer Control Unit" , TF-80, "Transfer Control Device"	L M
14	PNP switch signal	When A/T PNP switch signal is malfunction or communication error between the vehicles.	TF-87, "Park/Neutral Position Switch (M/T Models)"	
Repeats flickering every 0.25 sec.	Data erase display	<ul style="list-style-type: none"> ● Power supply failure of memory back-up. ● Battery is disconnected for a long time. ● Battery performance is poor. 	TF-51, "Power Supply Circuit For Transfer Control Unit"	
Repeats flickering every 2 to 5 sec.	—	Circuits that the self-diagnosis covers have no malfunction.	—	
No flickering	PNP switch or 4WD shift switch	PNP switch or 4WD shift switch circuit is shorted or open.	TF-87, "Park/Neutral Position Switch (M/T Models)" or TF-59, "4WD Shift Switch"	

NOTE:

If "actuator position switch" or "transfer control device" is displayed, first erase self-diagnostic results. (They may be displayed after installing transfer control unit or transfer assembly.)

TROUBLE DIAGNOSIS

ERASE SELF-DIAGNOSIS

- In order to make it easier to find the cause of hard-to-duplicate malfunctions, malfunction information is stored into the control unit as necessary during use by the user. This memory is not erased no matter how many times the ignition switch is turned ON and OFF.
- However, this information is erased by turning ignition switch “OFF” after performing self-diagnostics or by erasing the memory using the CONSULT-II.

TROUBLE DIAGNOSIS FOR SYSTEM

TROUBLE DIAGNOSIS FOR SYSTEM

PFP:00000

Power Supply Circuit For Transfer Control Unit CONSULT-II REFERENCE VALUE IN DATA MONITOR MODE

EDS002XU

Data are reference value.

Monitored item [Unit]	Content	Condition	Display value
BATTERY VOLT [V]	Power supply voltage for transfer control unit	Ignition switch: ON	Battery voltage

TRANSFER CONTROL UNIT TERMINALS AND REFERENCE VALUE

Data are reference value and are measured between each terminal and ground.

Terminal	Wire color	Item	Condition	Data (Approx.)
6	B	Ground	Always	0V
18	B	Ground	Always	0V
19	R	Power supply (Memory back-up)	Always	Battery voltage
25	W/G	Ignition switch monitor	Ignition switch: ON	Battery voltage
			Ignition switch: OFF	0V
32	B	Actuator motor ground	Always	0V
40	V	Transfer shut off relay	Ignition switch: ON	0V
			Ignition switch: OFF (5 seconds after ignition switch is turned OFF)	Battery voltage
44	Y	Power supply	Ignition switch: ON	Battery voltage
			Ignition switch: OFF (5 seconds after ignition switch is turned OFF)	0V
45	GR	Power supply	Ignition switch: ON	Battery voltage
			Ignition switch: OFF (5 seconds after ignition switch is turned OFF)	0V

CAUTION:

When using a circuit tester to measure voltage for inspection, be sure not to extend forcibly any connector terminals.

TROUBLE DIAGNOSIS FOR SYSTEM

DIAGNOSTIC PROCEDURE

1. CHECK POWER SUPPLY

1. Turn ignition switch "OFF". (Stay for at least 5 seconds.)
2. Disconnect transfer control unit harness connector.
3. Check voltage between transfer control unit harness connector terminals and ground.

Connector	Terminal	Voltage (Approx.)
M152	19 - Ground	Battery voltage
	25 - Ground	0V
M153	40 - Ground	Battery voltage
	44 - Ground	0V
	45 - Ground	

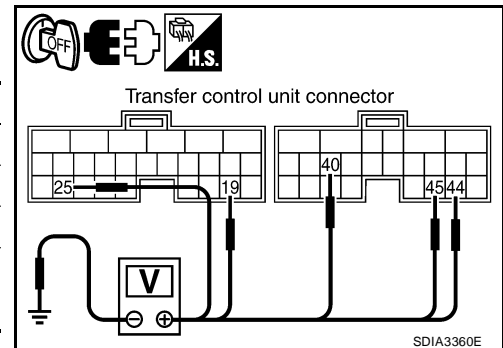

4. Turn ignition switch "ON". (Do not start engine.)
5. Check voltage between transfer control unit harness connector terminals and ground.

Connector	Terminal	Voltage (Approx.)
M152	19 - Ground	Battery voltage
	25 - Ground	
M153	40 - Ground	
	44 - Ground	
	45 - Ground	

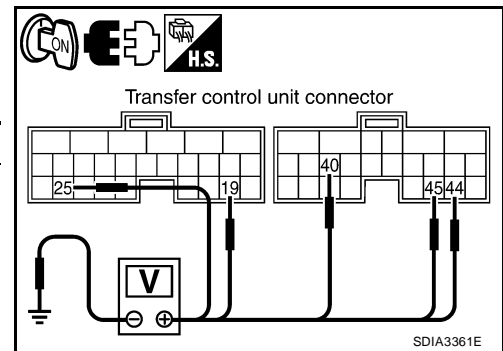

OK or NG

OK >> GO TO 2.

NG >> Check the following. If any items are damaged, repair or replace damaged parts.

- 40A fusible link (No. j , located in the fuse and fusible link box). Refer to [PG-4, "POWER SUPPLY ROUTING CIRCUIT"](#) .
- 10A fuses [No. 21, located in the fuse block (J/B) and Nos. 57 and 58 located in the fuse and relay box]. Refer to [PG-4, "POWER SUPPLY ROUTING CIRCUIT"](#) .
- Harness for short or open between battery and transfer control unit harness connector M152 terminal 19.
- Harness for short or open between battery and transfer shut off relay 2 harness connector E157 terminal 1 and 3.
- Harness for short or open between battery and transfer shut off relay 1 harness connector E156 terminal 3.
- Harness for short or open between ignition switch and transfer control unit harness connector M152 terminal 25.
- Harness for short or open between ignition switch and transfer shut off relay 1 harness connector E156 terminal 1.
- Harness for short or open between transfer shut off relay 2 harness connector E157 terminal 5 and transfer control unit harness connector M153 terminals 44, 45.
- Harness for short or open between transfer shut off relay 1 harness connector E156 terminal 5 and transfer control unit harness connector M153 terminals 44, 45.
- Harness for short or open between transfer shut off relay 2 harness connector E157 terminal 2 and transfer control unit harness connector M153 terminal 40.
- Harness for open between transfer shut off relay 1 harness connector E156 terminal 2 and ground.
- Battery and ignition switch. Refer to [PG-4, "POWER SUPPLY ROUTING CIRCUIT"](#) .
- Transfer shut off relay 1, 2. Refer to [TF-54, "COMPONENT INSPECTION"](#) .

TROUBLE DIAGNOSIS FOR SYSTEM

2. CHECK GROUND CIRCUIT

1. Turn ignition switch "OFF".
2. Disconnect transfer control unit harness connector.
3. Check continuity between transfer control unit harness connector M152 terminals 6 and 18, and M153 terminal 32 and ground.

Continuity should exist.

Also check harness for short to power.

OK or NG

OK >> GO TO 3.

NG >> Repair open circuit or short to power in harness or connectors.

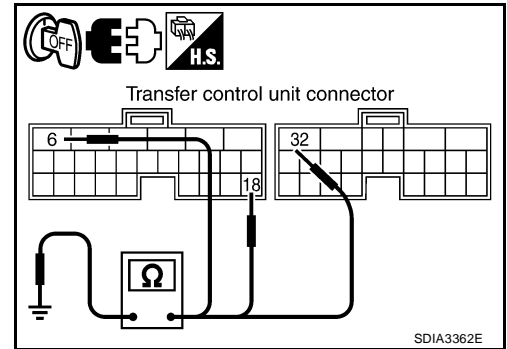

3. CHECK TRANSFER CONTROL UNIT

Check transfer control unit input/output signal. Refer to [TF-37, "Transfer Control Unit Input/Output Signal Reference Values"](#) .

OK or NG

OK >> GO TO 4.

NG >> Check transfer control unit pin terminals for damage or loose connection with harness connector. If any items are damaged, repair or replace damaged parts.

4. CHECK DTC

Perform the self-diagnosis, after driving vehicle for a while.

OK or NG

OK >> Inspection End.

NG >> Replace transfer control unit. Refer to [TF-102, "Removal and Installation"](#) .

TROUBLE DIAGNOSIS FOR SYSTEM

COMPONENT INSPECTION

1. Turn ignition switch "OFF". (Stay for at least 5 seconds.)
2. Remove transfer shut off relay 1 and transfer shut off relay 2. Refer to [TF-21, "Location of Electrical Parts"](#).
3. Apply 12V direct current between transfer shut off relay terminals 1 and 2.
4. Check continuity between relay terminals 3 and 5.

Condition	Continuity
12V direct current supply between terminals 1 and 2	Yes
OFF	No

5. If NG, replace the transfer shut off relay 1 or 2. Refer to [TF-21, "Location of Electrical Parts"](#).

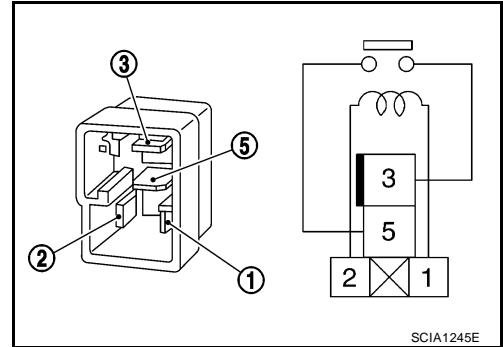

EDS002XV

Transfer Control Unit DIAGNOSTIC PROCEDURE

1. INSPECTION START

Do you have CONSULT-II?

YES or NO

- YES >> GO TO 2.
NO >> GO TO 3.

2. PERFORM SELF-DIAGNOSIS (WITH CONSULT-II)

With CONSULT-II

1. Turn ignition switch "ON". (Do not start engine.)
2. Select "SELF-DIAG RESULTS" mode for "ALL MODE AWD/4WD" with CONSULT-II.
3. Touch "ERASE".
4. Turn ignition switch "OFF" and wait at least 10 seconds.
5. Perform the self-diagnosis again.

Is the "CONTROL UNIT 1 [P1802]", "CONTROL UNIT 2 [P1803]", "CONTROL UNIT 3 [P1804]" or "CONTROL UNIT 4 [P1809]" displayed?

- YES >> Replace transfer control unit. Refer to [TF-102, "TRANSFER CONTROL UNIT"](#).
NO >> Inspection End.

3. PERFORM SELF-DIAGNOSIS (WITHOUT CONSULT-II)

Without CONSULT-II

1. Perform the self-diagnosis and then erase self-diagnostic results. Refer to [TF-47, "SELF-DIAGNOSTIC PROCEDURE \(WITHOUT CONSULT-II\)"](#) and [TF-50, "ERASE SELF-DIAGNOSIS"](#).
2. Perform the self-diagnosis again.

Do the self-diagnostic results indicate AD converter?

- YES >> Replace transfer control unit. Refer to [TF-102, "TRANSFER CONTROL UNIT"](#).
NO >> Inspection End.

Output Shaft Revolution Signal (TCM) DIAGNOSTIC PROCEDURE

EDS002XW

1. CHECK DTC WITH TCM

Perform self-diagnosis with TCM. Refer to [AT-90, "CONSULT-II SETTING PROCEDURE"](#).

Is any malfunction detected by self-diagnosis?

- YES >> Check the malfunctioning system.
NO >> GO TO 2.

TROUBLE DIAGNOSIS FOR SYSTEM

2. CHECK TRANSFER CONTROL UNIT

Check transfer control unit input/output signal. Refer to [TF-37, "Transfer Control Unit Input/Output Signal Reference Values"](#) .

OK or NG

OK >> GO TO 3.

NG >> Check transfer control unit pin terminals for damage or loose connection with harness connector.
If any items are damaged, repair or replace damaged parts.

3. CHECK DTC

Perform the self-diagnosis, after driving vehicle for a while.

OK or NG

OK >> Inspection End.

NG >> Perform self-diagnosis with TCM again. Refer to [AT-91, "SELF-DIAGNOSTIC RESULT MODE"](#) .

Vehicle Speed Sensor (ABS) DIAGNOSTIC PROCEDURE

EDS002XX

1. CHECK DTC WITH ABS ACTUATOR AND ELECTRIC UNIT (CONTROL UNIT)

Perform self-diagnosis with ABS actuator and electric unit (control unit).

Is any malfunction detected by self-diagnosis?

YES >> Check the malfunctioning system.

NO >> GO TO 2.

2. CHECK TRANSFER CONTROL UNIT

Check transfer control unit input/output signal. Refer to [TF-37, "Transfer Control Unit Input/Output Signal Reference Values"](#) .

OK or NG

OK >> GO TO 3.

NG >> Check transfer control unit pin terminals for damage or loose connection with harness connector.
If any items are damaged, repair or replace damaged parts.

3. CHECK DTC

Perform the self-diagnosis, after driving a vehicle for a while.

OK or NG

OK >> Inspection End.

NG >> Perform self-diagnosis with ABS actuator and electric unit (control unit).

TROUBLE DIAGNOSIS FOR SYSTEM

4LO Switch

EDS002XY

CONSULT-II REFERENCE VALUE IN DATA MONITOR MODE

Data are reference value.

Monitored item	Content	Condition	Display value
4L POSI SW [ON/OFF]	Condition of 4LO switch	<ul style="list-style-type: none"> ● Vehicle stopped ● Engine running ● For A/T models, A/T selector lever "N" position with brake pedal depressed. ● For M/T models, M/T shift lever neutral position with clutch and brake pedal depressed. 	4WD shift switch: 4LO ON
		Except the above	OFF

TRANSFER CONTROL UNIT TERMINALS AND REFERENCE VALUE

Data are reference value and are measured between each terminal and ground.

Terminal	Wire color	Item	Condition	Data (Approx.)
24	Y	4LO switch	<ul style="list-style-type: none"> ● Vehicle stopped ● Engine running ● For A/T models, A/T selector lever "N" position with brake pedal depressed. ● For M/T models, M/T shift lever neutral position with clutch and brake pedal depressed. 	4WD shift switch: 4LO 0V
			Except the above	Battery voltage

CAUTION:

When using a circuit tester to measure voltage for inspection, be sure not to extend forcibly any connector terminals.

TROUBLE DIAGNOSIS FOR SYSTEM

DIAGNOSTIC PROCEDURE

1. CHECK 4LO POSITION SWITCH SIGNAL

④ With CONSULT-II

1. Start engine.
2. Select "DATA MONITOR" mode for "ALL MODE AWD/4WD" with CONSULT-II.
3. Read out the value of "4L POSI SW".

Condition	Display value
<ul style="list-style-type: none"> ● Vehicle stopped ● Engine running ● For A/T models, A/T selector lever "N" position with brake pedal depressed. ● For M/T models, M/T shift lever neutral position with clutch and brake pedal depressed. 	4WD shift switch: 4LO ON
Except the above	OFF

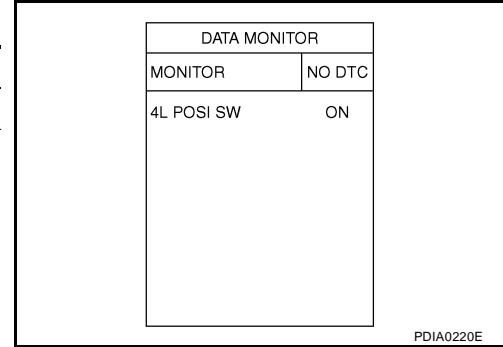

⊗ Without CONSULT-II

1. Start engine.
2. Check voltage between transfer control unit harness connector terminal and ground.

Connector	Terminal	Condition	Voltage (Approx.)
M152	24 - Ground	<ul style="list-style-type: none"> ● Vehicle stopped ● Engine running ● For A/T models, A/T selector lever "N" position with brake pedal depressed. ● For M/T models, M/T shift lever neutral position with clutch and brake pedal depressed. 	4WD shift switch: 4LO 0V
		Except the above	Battery voltage

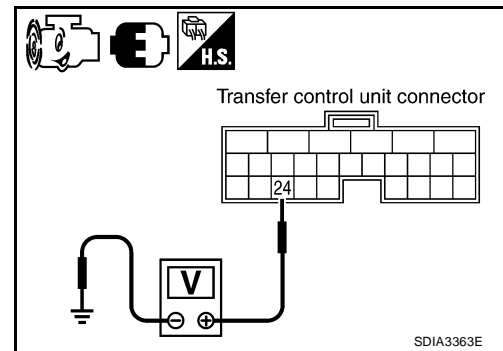

OK or NG

- OK >> GO TO 5.
NG >> GO TO 2.

2. CHECK HARNESS BETWEEN TRANSFER CONTROL UNIT AND 4LO SWITCH

1. Turn ignition switch "OFF". (Stay for at least 5 seconds.)
2. Disconnect transfer control unit harness connector and the 4LO switch harness connector.
3. Check continuity between transfer control unit harness connector M152 terminal 24 and 4LO switch harness connector F60 terminal 13.

Continuity should exist.

Also check harness for short to ground and short to power.

OK or NG

- OK >> GO TO 3.
NG >> Repair or replace damaged parts.

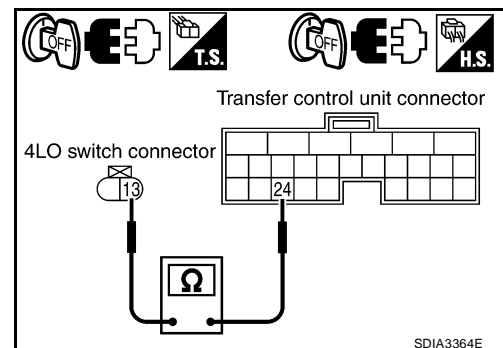

TROUBLE DIAGNOSIS FOR SYSTEM

3. CHECK GROUND CIRCUIT

1. Turn ignition switch "OFF". (Stay for at least 5 seconds.)
2. Disconnect 4LO switch harness connector.
3. Check continuity between 4LO switch harness connector F60 terminal 12 and ground.

Continuity should exist.

Also check harness for short to power.

OK or NG

OK >> GO TO 4.

NG >> Repair open circuit or short to power in harness or connectors.

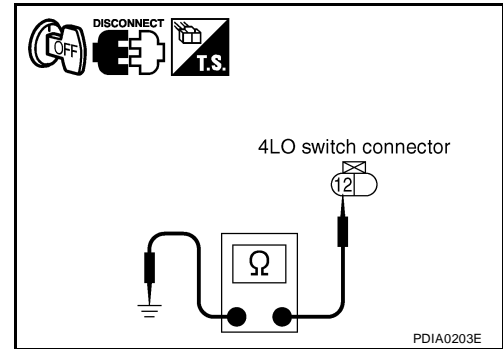

4. CHECK 4LO SWITCH

1. Turn ignition switch "OFF". (Stay for at least 5 seconds.)
2. Disconnect 4LO switch harness connector.
3. Remove 4LO switch. Refer to [TF-21, "Location of Electrical Parts"](#).
4. Push and release 4LO switch and check continuity between 4LO switch terminals 12 and 13.

Terminal	Condition	Continuity
12 - 13	Push 4LO switch	Yes
	Release 4LO switch	No

OK or NG

OK >> GO TO 5.

NG >> Replace 4LO switch. Refer to [TF-21, "Location of Electrical Parts"](#).

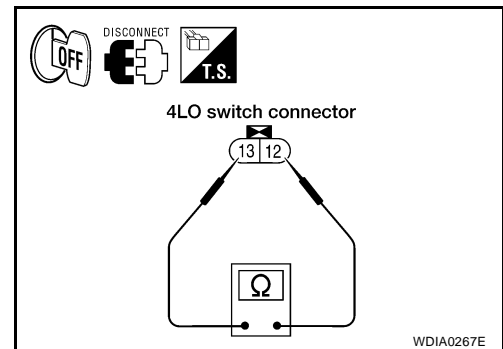

5. CHECK TRANSFER CONTROL UNIT

Check transfer control unit input/output signal. Refer to [TF-37, "Transfer Control Unit Input/Output Signal Reference Values"](#).

OK or NG

OK >> GO TO 6.

NG >> Check transfer control unit pin terminals for damage or loose connection with harness connector. If any items are damaged, repair or replace damaged parts.

6. CHECK DTC

Perform the self-diagnosis, after driving a vehicle for a while.

OK or NG

OK >> Inspection End.

NG >> Replace transfer control unit. Refer to [TF-102, "Removal and Installation"](#).

TROUBLE DIAGNOSIS FOR SYSTEM

COMPONENT INSPECTION

1. Turn ignition switch "OFF". (Stay for at least 5 seconds.)
2. Disconnect 4LO switch harness connector.
3. Remove 4LO switch. Refer to [TF-21, "Location of Electrical Parts"](#).
4. Push and release 4LO switch and check continuity between 4LO switch terminals 12 and 13.

Terminal	Condition	Continuity
12 - 13	Push 4LO switch	Yes
	Release 4LO switch	No

5. If NG, replace the 4LO switch.

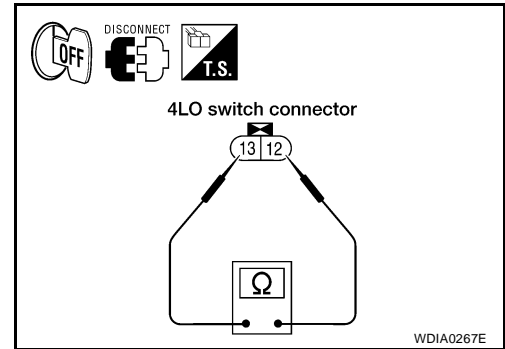

4WD Shift Switch

CONSULT-II REFERENCE VALUE IN DATA MONITOR MODE

EDS002XZ

Data are reference value.

Monitored item [Unit]	Content	Condition	Display value
2WD SWITCH [ON/OFF]	Input condition from 4WD shift switch	4WD shift switch: 2WD	ON
		4WD shift switch: 4H and 4LO	OFF
4H SWITCH [ON/OFF]	Input condition from 4WD shift switch	4WD shift switch: 4H	ON
		4WD shift switch: 2WD and 4LO	OFF
4L SWITCH [ON/OFF]	Input condition from 4WD shift switch	4WD shift switch: 4LO	ON
		4WD shift switch: 2WD and 4H	OFF
4WD MODE [2H/4H/4L]	Control status of 4WD (Output condition of 4WD shift indicator lamp and 4LO indicator lamp)	4WD shift switch (Engine running): 2WD	2H
		4WD shift switch (Engine running): 4H	4H
		4WD shift switch (Engine running): 4LO	4L

TRANSFER CONTROL UNIT TERMINALS AND REFERENCE VALUE

Data are reference value and are measured between each terminal and ground.

Terminal	Wire color	Item	Condition	Data (Approx.)
14	G	4WD shift switch (2WD)	4WD shift switch: 2WD	Battery voltage
			4WD shift switch: 4H and 4LO	0V
15	O	4WD shift switch (4H)	4WD shift switch: 4H	Battery voltage
			4WD shift switch: 2WD and 4LO	0V
16	W	4WD shift switch (4LO)	4WD shift switch: 4LO	Battery voltage
			4WD shift switch: 2WD and 4H	0V

CAUTION:

When using a circuit tester to measure voltage for inspection, be sure not to extend forcibly any connector terminals.

TROUBLE DIAGNOSIS FOR SYSTEM

DIAGNOSTIC PROCEDURE

1. CHECK 4WD SHIFT SWITCH SIGNAL

④ With CONSULT-II

1. Turn ignition switch "ON".
2. Select "DATA MONITOR" mode for "ALL MODE AWD/4WD" with CONSULT-II.
3. Read out ON/OFF switching action of the "2WD SWITCH", "4H SWITCH", "4L SWITCH" with operating 4WD shift switch.

DATA MONITOR	
MONITOR	NO DTC
2WD SWITCH	OFF
4H SWITCH	ON
4L SWITCH	OFF

SDIA2382E

⊗ Without CONSULT-II

1. Turn ignition switch "ON".
2. Check voltage between transfer control unit harness connector terminals and ground.

Connector	Terminal	Condition	Voltage (Approx.)
M152	14 - Ground	4WD shift switch: 2WD	Battery voltage
		4WD shift switch: 4H and 4LO	0V
	15 - Ground	4WD shift switch: 4H	Battery voltage
		4WD shift switch: 2WD and 4LO	0V
	16 - Ground	4WD shift switch: 4LO	Battery voltage
		4WD shift switch: 2WD and 4H	0V

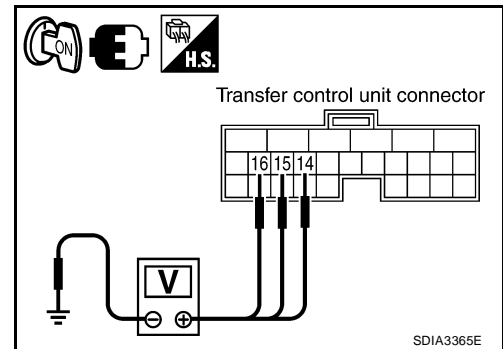

OK or NG

- OK >> GO TO 5.
 NG >> GO TO 2.

TROUBLE DIAGNOSIS FOR SYSTEM

2. CHECK 4WD SHIFT SWITCH POWER SUPPLY CIRCUIT

1. Turn ignition switch "OFF". (Stay for at least 5 seconds.)
2. Disconnect 4WD shift switch harness connector.
3. Check voltage between 4WD shift switch harness connector terminal 1 and ground.

Connector	Terminal	Voltage (Approx.)
M141	1 - Ground	0V

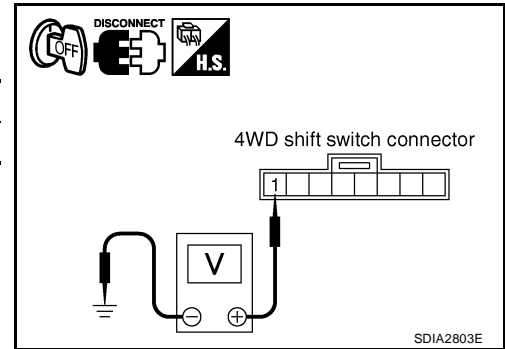

4. Turn ignition switch "ON". (Do not start engine.)
5. Check voltage between 4WD shift switch harness connector terminal 1 and ground.

Connector	Terminal	Voltage (Approx.)
M141	1 - Ground	Battery voltage

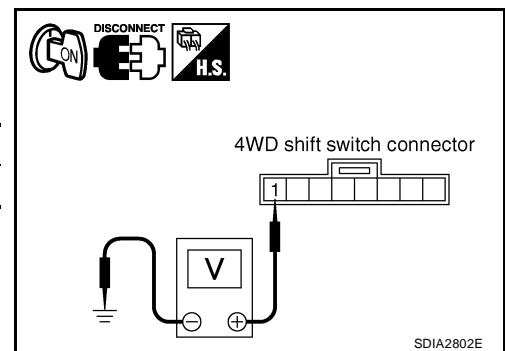

OK or NG

OK >> GO TO 3.

NG >> 1. Check harness for short or open between 4WD shift switch harness connector terminal 1 and transfer shut off relay 2 harness connector E157 terminal 5 and 10A fuse (No. 58 located in the fuse and relay box). If any items are damaged, repair or replace damaged parts.

2. Perform trouble diagnosis for power supply circuit. Refer to [TF-51, "Power Supply Circuit For Transfer Control Unit"](#).

3. CHECK HARNESS BETWEEN 4WD SHIFT SWITCH AND TRANSFER CONTROL UNIT

1. Turn ignition switch "OFF". (Stay for at least 5 seconds.)
2. Disconnect transfer control unit harness connector and the 4WD shift switch harness connector.
3. Check continuity between the following terminals.
 - Transfer control unit harness connector M152 terminal 14 and 4WD shift switch harness connector M141 terminal 3.
 - Transfer control unit harness connector M152 terminal 15 and 4WD shift switch harness connector M141 terminal 5.
 - Transfer control unit harness connector M152 terminal 16 and 4WD shift switch harness connector M141 terminal 6.

Continuity should exist.

Also check harness for short to ground and short to power.

OK or NG

OK >> GO TO 4.

NG >> Repair or replace damaged parts.

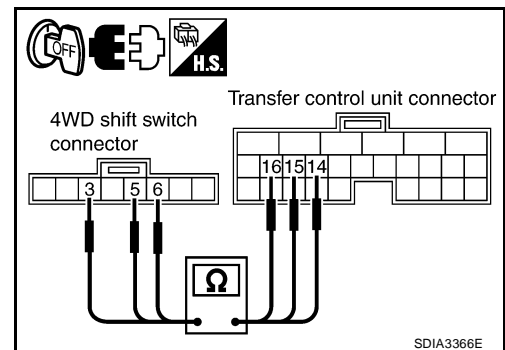

TROUBLE DIAGNOSIS FOR SYSTEM

4. CHECK 4WD SHIFT SWITCH

1. Turn ignition switch "OFF". (Stay for at least 5 seconds.)
2. Remove 4WD shift switch harness connector.
3. Operate 4WD shift switch and check continuity between 4WD shift switch terminals.

Terminal	Condition	Continuity
1 - 3	4WD shift switch: 2WD	Yes
	4WD shift switch: 4H and 4LO	No
1 - 5	4WD shift switch: 4H	Yes
	4WD shift switch: 2WD and 4LO	No
1 - 6	4WD shift switch: 4LO	Yes
	4WD shift switch: 2WD and 4H	No

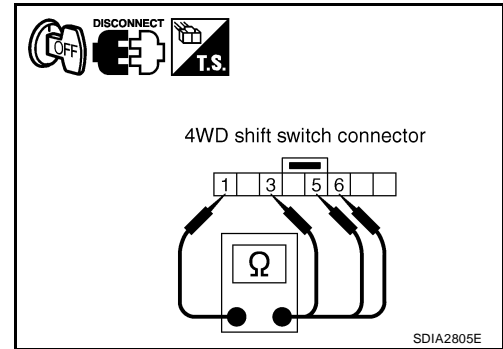

OK or NG

- OK >> GO TO 5.
- NG >> Replace 4WD shift switch.

5. CHECK TRANSFER CONTROL UNIT

Check transfer control unit input/output signal. Refer to [TF-37, "Transfer Control Unit Input/Output Signal Reference Values"](#) .

OK or NG

- OK >> GO TO 6.
- NG >> Check transfer control unit pin terminals for damage or loose connection with harness connector. If any items are damaged, repair or replace damaged parts.

6. CHECK DTC

Perform the self-diagnosis, after driving a vehicle for a while.

OK or NG

- OK >> Inspection End.
- NG >> Replace transfer control unit. Refer to [TF-102, "Removal and Installation"](#) .

TROUBLE DIAGNOSIS FOR SYSTEM

COMPONENT INSPECTION

1. Turn ignition switch "OFF". (Stay for at least 5 seconds.)
2. Remove 4WD shift switch harness connector.
3. Operate 4WD shift switch and check continuity between 4WD shift switch terminals.

Terminal	Condition	Continuity
1 - 3	4WD shift switch: 2WD	Yes
	4WD shift switch: 4H and 4LO	No
1 - 5	4WD shift switch: 4H	Yes
	4WD shift switch: 2WD and 4LO	No
1 - 6	4WD shift switch: 4LO	Yes
	4WD shift switch: 2WD and 4H	No

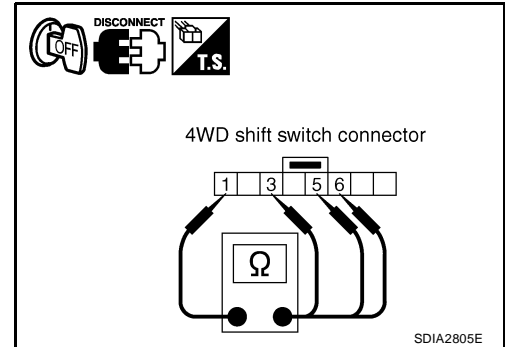

4. If NG, replace the 4WD shift switch.

Wait Detection Switch

EDS002Y0

CONSULT-II REFERENCE VALUE IN DATA MONITOR MODE

Data are reference value.

Monitored item	Content	Condition	Display value
WAIT DETCT SW [ON/OFF]	Condition of wait detection switch	<ul style="list-style-type: none"> ● Vehicle stopped ● Engine running ● For A/T models, A/T selector lever "N" position with brake pedal depressed. ● For M/T models, M/T shift lever neutral position with clutch and brake pedal depressed. 	4WD shift switch : 4H and 4LO ON
		4WD shift switch: 2WD	OFF

TRANSFER CONTROL UNIT TERMINALS AND REFERENCE VALUE

Data are reference value and are measured between each terminal and ground.

Terminal	Wire color	Item	Condition	Data (Approx.)
17	O	Wait detection switch	<ul style="list-style-type: none"> ● Vehicle stopped ● Engine running ● For A/T models, A/T selector lever "N" position with brake pedal depressed. ● For M/T models, M/T shift lever neutral position with clutch and brake pedal depressed. 	4WD shift switch: 4H and 4LO 0V
			4WD shift switch: 2WD	Battery voltage

CAUTION:

When using a circuit tester to measure voltage for inspection, be sure not to extend forcibly any connector terminals.

TROUBLE DIAGNOSIS FOR SYSTEM

DIAGNOSTIC PROCEDURE

1. CHECK WAIT DETECTION SWITCH SIGNAL

④ With CONSULT-II

1. Start engine.
2. Select "DATA MONITOR" mode for "ALL MODE AWD/4WD" with CONSULT-II.
3. Read out the value of "WAIT DETCT SW".

Condition		Display value
<ul style="list-style-type: none"> ● Vehicle stopped ● Engine running ● For A/T models, A/T selector lever "N" position with brake pedal depressed. ● For M/T models, M/T shift lever neutral position with clutch and brake pedal depressed. 	4WD shift switch: 4H and 4LO	ON
	4WD shift switch: 2WD	OFF

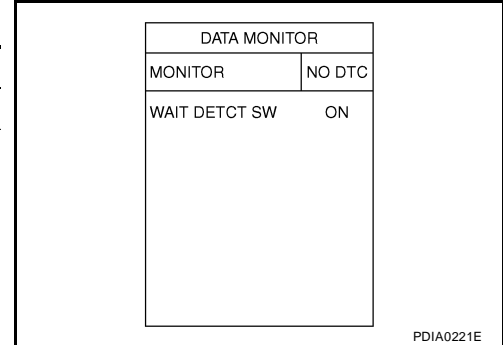

⊗ Without CONSULT-II

1. Start engine.
2. Check voltage between transfer control unit harness connector terminal and ground.

Connector	Terminal	Condition	Voltage (Approx.)
M152	17 - Ground	<ul style="list-style-type: none"> ● Vehicle stopped ● Engine running ● For A/T models, A/T selector lever "N" position with brake pedal depressed. ● For M/T models, M/T shift lever neutral position with clutch and brake pedal depressed. 	0V
		4WD shift switch: 2WD	Battery voltage

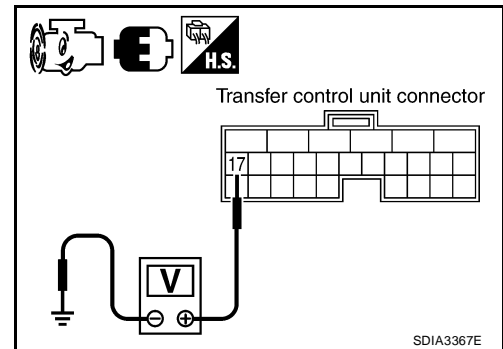

OK or NG

- OK >> GO TO 5.
 NG >> GO TO 2.

TROUBLE DIAGNOSIS FOR SYSTEM

2. CHECK HARNESS BETWEEN TRANSFER CONTROL UNIT AND WAIT DETECTION SWITCH

1. Turn ignition switch "OFF". (Stay for at least 5 seconds.)
2. Disconnect transfer control unit harness connector and the wait detection switch harness connector.
3. Check continuity between transfer control unit harness connector M152 terminal 17 and wait detection switch harness connector F59 terminal 10.

Continuity should exist.

Also check harness for short to ground and short to power.

OK or NG

- OK >> GO TO 3.
 NG >> Repair or replace damaged parts.

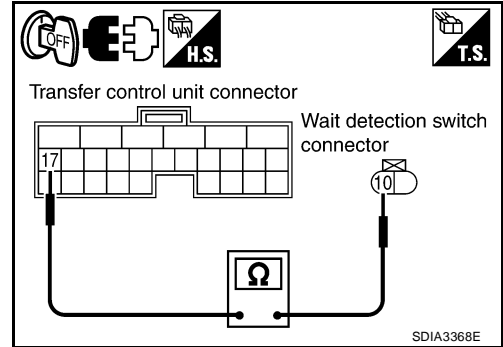

3. CHECK GROUND CIRCUIT

1. Turn ignition switch "OFF". (Stay for at least 5 seconds.)
2. Disconnect wait detection switch harness connector.
3. Check continuity between wait detection switch harness connector F59 terminal 11 and ground.

Continuity should exist.

Also check harness for short to power.

OK or NG

- OK >> GO TO 4.
 NG >> Repair open circuit or short to power in harness or connectors.

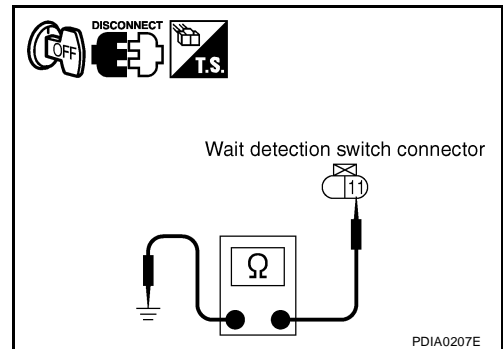

4. CHECK WAIT DETECTION SWITCH

1. Turn ignition switch "OFF". (Stay for at least 5 seconds.)
2. Disconnect wait detection switch harness connector.
3. Remove wait detection switch. Refer to [TF-21, "Location of Electrical Parts"](#).
4. Push and release wait detection switch and check continuity between wait detection switch terminals 10 and 11.

Terminal	Condition	Continuity
10 - 11	Push wait detection switch	Yes
	Release wait detection switch	No

OK or NG

- OK >> GO TO 5.
 NG >> Replace wait detection switch. Refer to [TF-21, "Location of Electrical Parts"](#).

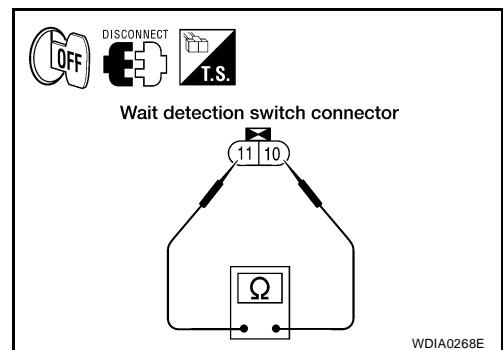

5. CHECK TRANSFER CONTROL UNIT

Check transfer control unit input/output signal. Refer to [TF-37, "Transfer Control Unit Input/Output Signal Reference Values"](#).

OK or NG

- OK >> GO TO 6.
 NG >> Check transfer control unit pin terminals for damage or loose connection with harness connector. If any items are damaged, repair or replace damaged parts.

TROUBLE DIAGNOSIS FOR SYSTEM

6. CHECK DTC

Perform the self-diagnosis, after driving a vehicle for a while.

OK or NG

- OK >> Inspection End.
- NG >> Replace transfer control unit. Refer to [TF-102, "Removal and Installation"](#) .

TROUBLE DIAGNOSIS FOR SYSTEM

COMPONENT INSPECTION

1. Turn ignition switch "OFF". (Stay for at least 5 seconds.)
2. Disconnect wait detection switch harness connector.
3. Remove wait detection switch. Refer to [TF-21, "Location of Electrical Parts"](#).
4. Push and release wait detection switch and check continuity between wait detection switch terminals 10 and 11.

Terminal	Condition	Continuity
10 - 11	Push wait detection switch	Yes
	Release wait detection switch	No

5. If NG, replace the wait detection switch. Refer to [TF-21, "Location of Electrical Parts"](#).

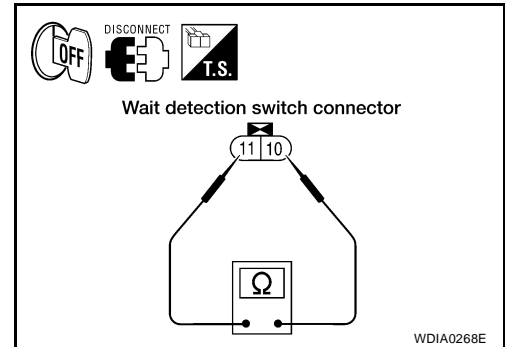

EDS002Y1

PNP Switch Signal (A/T models) DIAGNOSTIC PROCEDURE

1. CHECK DTC WITH TCM

Perform self-diagnosis with TCM. Refer to [AT-90, "CONSULT-II SETTING PROCEDURE"](#).

Is any malfunction detected by self-diagnosis?

- YES >> Check the malfunctioning system.
NO >> GO TO 2.

2. CHECK TRANSFER CONTROL UNIT

Check transfer control unit input/output signal. Refer to [TF-37, "Transfer Control Unit Input/Output Signal Reference Values"](#).

OK or NG

- OK >> GO TO 3.
NG >> Check transfer control unit pin terminals for damage or loose connection with harness connector. If any items are damaged, repair or replace damaged parts.

3. CHECK DTC

Perform the self-diagnosis, after driving a vehicle for a while.

OK or NG

- OK >> Inspection End.
NG >> Perform self-diagnosis with TCM again. Refer to [AT-90, "CONSULT-II SETTING PROCEDURE"](#).

TROUBLE DIAGNOSIS FOR SYSTEM

EDS002Y2

Actuator Motor

CONSULT-II REFERENCE VALUE IN DATA MONITOR MODE

Data are reference value.

Monitored item	Content	Condition	Display value
SHIFT ACT 1 [ON/OFF]	Output condition to actuator motor (clockwise)	<ul style="list-style-type: none"> ● Vehicle stopped ● Engine running ● For A/T models, A/T selector lever "N" position with brake pedal depressed. ● For M/T models, M/T shift lever neutral position with clutch and brake pedal depressed. 	4WD shift switch : 2WD to 4H or 4H to 4LO or 2WD to 4LO ON
		Except the above	OFF
SHIFT AC MON1 [ON/OFF]	Check signal for transfer control unit signal output	<ul style="list-style-type: none"> ● Vehicle stopped ● Engine running ● For A/T models, A/T selector lever "N" position with brake pedal depressed. ● For M/T models, M/T shift lever neutral position with clutch and brake pedal depressed. 	4WD shift switch : 2WD to 4H or 4H to 4LO or 2WD to 4LO ON
		Except the above	OFF
SHIFT ACT 2 [ON/OFF]	Output condition to actuator motor (counterclockwise)	<ul style="list-style-type: none"> ● Vehicle stopped ● Engine running ● For A/T models, A/T selector lever "N" position with brake pedal depressed. ● For M/T models, M/T shift lever neutral position with clutch and brake pedal depressed. 	4WD shift switch : 4LO to 4H or 4H to 2WD or 4LO to 2WD ON
		Except the above	OFF
SHIFT AC MON2 [ON/OFF]	Check signal for transfer control unit signal output	<ul style="list-style-type: none"> ● Vehicle stopped ● Engine running ● For A/T models, A/T selector lever "N" position with brake pedal depressed. ● For M/T models, M/T shift lever neutral position with clutch and brake pedal depressed. 	4WD shift switch : 4LO to 4H or 4H to 2WD or 4LO to 2WD ON
		Except the above	OFF

TRANSFER CONTROL UNIT TERMINALS AND REFERENCE VALUE

Data are reference value and are measured between each terminal and ground.

Terminal	Wire color	Item	Condition	Data (Approx.)
27	L	Actuator motor power supply	Ignition switch: ON	Battery voltage
			Ignition switch: OFF (5 seconds after ignition switch is turned OFF)	0V

TROUBLE DIAGNOSIS FOR SYSTEM

Terminal	Wire color	Item	Condition		Data (Approx.)
28	SB	Actuator motor (+)	<ul style="list-style-type: none"> ● Vehicle stopped ● Engine running ● For A/T models, A/T selector lever "N" position with brake pedal depressed. ● For M/T models, M/T shift lever neutral position with clutch and brake pedal depressed. 	When 4WD shift switch is operated (while actuator motor is operating)	Battery voltage
				When 4WD shift switch is not operated	0V
31	G	Actuator motor (-)	Always		0V
42	LG	Transfer shift high relay	<ul style="list-style-type: none"> ● Vehicle stopped ● Engine running ● For A/T models, A/T selector lever "N" position with brake pedal depressed. ● For M/T models, M/T shift lever neutral position with clutch and brake pedal depressed. 	4WD shift switch: 2WD to 4H or 4H to 4LO or 2WD to 4LO	0V
				Except the above	Battery voltage
47	O	Transfer shift high relay monitor	<ul style="list-style-type: none"> ● For A/T models, A/T selector lever "N" position with brake pedal depressed. ● For M/T models, M/T shift lever neutral position with clutch and brake pedal depressed. 	4WD shift switch: 2WD to 4H or 4H to 4LO or 2WD to 4LO	Battery voltage → 0V
				Except the above	0V
48	R	Transfer shift low relay monitor	<ul style="list-style-type: none"> ● For M/T models, M/T shift lever neutral position with clutch and brake pedal depressed. 	4WD shift switch: 4LO to 4H or 4H to 2WD or 4LO to 2WD	Battery voltage → 0V
				Except the above	0V
50	Y	Transfer shift low relay	<ul style="list-style-type: none"> ● For M/T models, M/T shift lever neutral position with clutch and brake pedal depressed. 	4WD shift switch: 4LO to 4H or 4H to 2WD or 4LO to 2WD	0V
				Except the above	Battery voltage

CAUTION:

When using a circuit tester to measure voltage for inspection, be sure not to extend forcibly any connector terminals.

A
B
C
TF
E
F
G
H
I
J
K
L
M

TROUBLE DIAGNOSIS FOR SYSTEM

DIAGNOSTIC PROCEDURE

1. CHECK ACTUATOR MOTOR SIGNAL

Ⓟ With CONSULT-II

1. Start engine.
2. Select "DATA MONITOR" mode for "ALL MODE AWD/4WD" with CONSULT-II.
3. Read out the value of "SHIFT ACT1", "SHIFT AC MON1", "SHIFT ACT2", "SHIFT AC MON2".

Monitored item	Condition	Display value
SHIFT ACT1	<ul style="list-style-type: none"> ● Vehicle stopped 	4WD shift switch: 2WD to 4H or 4H to 4LO or 2WD to 4LO
	<ul style="list-style-type: none"> ● Engine running 	Except the above
SHIFT AC MON1	<ul style="list-style-type: none"> ● For A/T models, A/T selector lever "N" position with brake pedal depressed. 	4WD shift switch: 2WD to 4H or 4H to 4LO or 2WD to 4LO
		Except the above
SHIFT ACT2	<ul style="list-style-type: none"> ● For M/T models, M/T shift lever neutral position with clutch and brake pedal depressed. 	4WD shift switch: 4LO to 4H or 4H to 2WD or 4LO to 2WD
		Except the above
SHIFT AC MON2	<ul style="list-style-type: none"> ● For M/T models, M/T shift lever neutral position with clutch and brake pedal depressed. 	4WD shift switch: 4LO to 4H or 4H to 2WD or 4LO to 2WD
		Except the above

DATA MONITOR	
MONITOR	NO DTC
SHIFT ACT1	OFF
SHIFT AC MON1	OFF
SHIFT ACT2	OFF
SHIFT AC MON2	OFF

PDIA0223E

ⓧ Without CONSULT-II

1. Start engine.
2. Depress brake pedal and stop vehicle.
3. For A/T models, set A/T selector lever to "N" position. For M/T models set M/T shift lever to neutral.
4. Check voltage between transfer control unit harness connector terminal and ground.

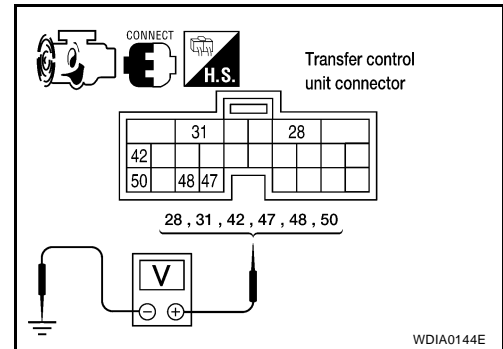

TROUBLE DIAGNOSIS FOR SYSTEM

Connector	Terminal	Condition		Voltage (Approx.)	
M153	28 - Ground	When 4WD shift switch is operated (While actuator motor is operating.)		Battery voltage → 0V	A
		When 4WD shift switch is not operated		0V	B
	31 - Ground	Always		0V	C
M153	42 - Ground	<ul style="list-style-type: none"> ● Vehicle stopped ● Engine running ● For A/T models, A/T selector lever "N" position with brake pedal depressed. ● For M/T models, M/T shift lever neutral position with clutch and brake pedal depressed. 	4WD shift switch: 2WD to 4H or 4H to 4LO or 2WD to 4LO	0V	TF
			Except the above	Battery voltage	
M153	47 - Ground	<ul style="list-style-type: none"> ● For A/T models, A/T selector lever "N" position with brake pedal depressed. ● For M/T models, M/T shift lever neutral position with clutch and brake pedal depressed. 	4WD shift switch: 2WD to 4H or 4H to 4LO or 2WD to 4LO	Battery voltage → 0V	E
			Except the above	0V	F
	48 - Ground		4WD shift switch: 4LO to 4H or 4H to 2WD or 4LO to 2WD	Battery voltage → 0V	G
			Except the above	0V	
	50 - Ground		4WD shift switch: 4LO to 4H or 4H to 2WD or 4LO to 2WD	0V	H
			Except the above	Battery voltage	I

OK or NG

- OK >> GO TO 9.
- NG >> GO TO 2.

A
B
C
TF
E
F
G
H
I
J
K
L
M

TROUBLE DIAGNOSIS FOR SYSTEM

2. CHECK ACTUATOR MOTOR POWER SUPPLY CIRCUIT

1. Turn ignition switch "OFF". (Stay for at least 5 seconds.)
2. Disconnect transfer control unit harness connector.
3. Check voltage between transfer control unit harness connector terminal 27 and ground.

Connector	Terminal	Voltage (Approx.)
M153	27 - Ground	0V

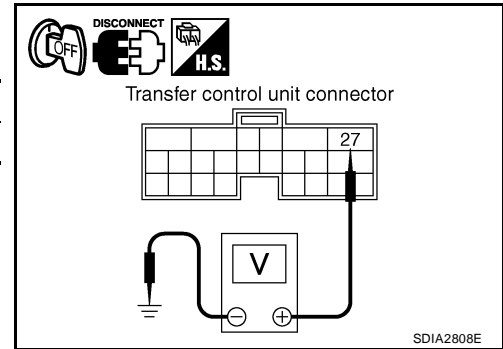

4. Turn ignition switch "ON".
5. Check voltage between transfer control unit harness connector terminal 27 and ground.

Connector	Terminal	Voltage (Approx.)
M153	27 - Ground	Battery voltage

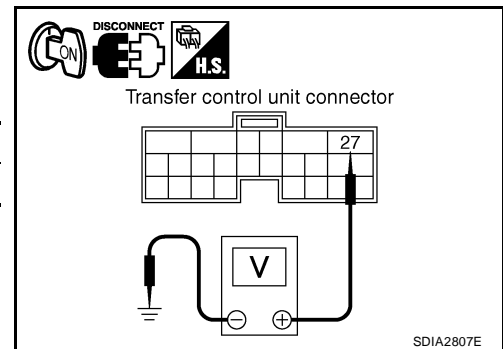

OK or NG

OK >> GO TO 3.

NG >> 1. Check harness for short or open between transfer control unit harness connector M153 terminal 27 and transfer shut off relay 2 harness connector E157 terminal 5 and 10A fuse (No. 57, located in the fuse and relay box). If any items are damaged, repair or replace damaged parts.

2. Perform trouble diagnosis for power supply circuit. Refer to [TF-51, "Power Supply Circuit For Transfer Control Unit"](#).

TROUBLE DIAGNOSIS FOR SYSTEM

3. CHECK TRANSFER RELAY POWER SUPPLY CIRCUIT

1. Turn ignition switch "OFF". (Stay for at least 5 seconds.)
2. Remove transfer shift high relay and transfer shift low relay. Refer to [TF-21, "Location of Electrical Parts"](#)
3. Check voltage between transfer control unit harness connector terminal and ground.

Connector	Terminal	Voltage (Approx.)
E46	2 - Ground	0V
E47	2 - Ground	0V

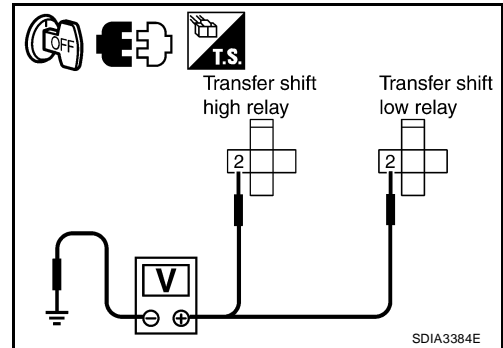

4. Turn ignition switch "ON". (Do not start engine.)
5. Check voltage between transfer control unit harness connector terminal and ground.

Connector	Terminal	Voltage (Approx.)
E46	2 - Ground	Battery voltage
E47	2 - Ground	Battery voltage

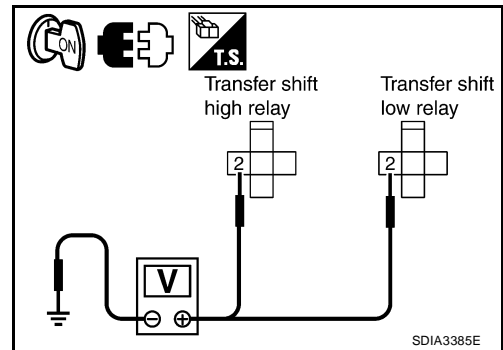

OK or NG

OK >> GO TO 4.

NG >> Check the following. If any items are damaged, repair or replace damaged parts.

- Harness for short or open between transfer control unit harness connector terminal 27 and transfer shift high relay harness connector E46 terminal 2.
- Harness for short or open between transfer control unit harness connector terminal 27 and transfer shift low relay harness connector terminal E47 terminal 2.

4. CHECK TRANSFER RELAY

1. Turn ignition switch "OFF". (Stay for at least 5 seconds.)
2. Remove transfer shift high relay and transfer shift low relay.
3. Apply 12V direct current between transfer shift high and low relay terminals 1 and 2.
4. Check continuity between relay terminals 3 and 4, 3 and 5.

Terminal	Condition	Continuity
3 - 4	12V direct current supply between terminals 1 and 2	No
	OFF	Yes
3 - 5	12V direct current supply between terminals 1 and 2	Yes
	OFF	No

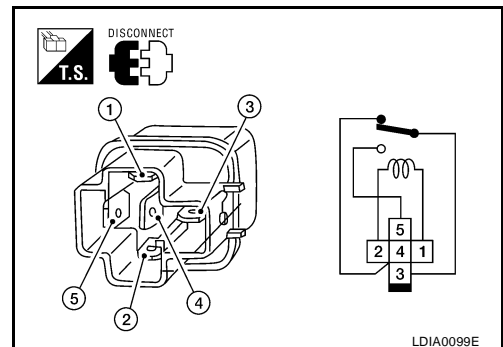

OK or NG

OK >> GO TO 5.

NG >> Replace the transfer shift high or low relay.

TROUBLE DIAGNOSIS FOR SYSTEM

5. CHECK (1): HARNESS BETWEEN TRANSFER CONTROL UNIT AND TRANSFER SHIFT RELAY

1. Turn ignition switch "OFF". (Stay for at least 5 seconds.)
2. Disconnect transfer control unit harness connector.
3. Remove transfer shift high relay and transfer shift low relay.
4. Check continuity between the following terminals.
 - Transfer control unit harness connector M153 terminal 42 and transfer shift high relay harness connector E46 terminal 1.
 - Transfer control unit harness connector M153 terminal 50 and transfer shift low relay harness connector E47 terminal 1.

Continuity should exist.

Also check harness for short to ground and short to power.

OK or NG

- OK >> GO TO 6.
- NG >> Repair or replace damaged parts.

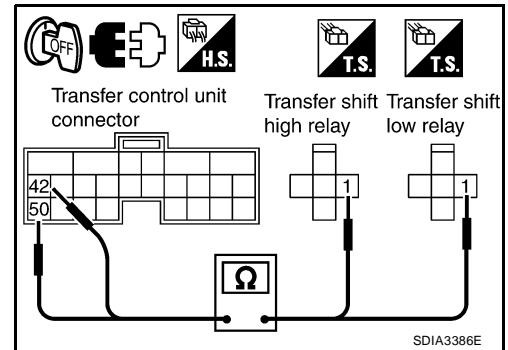

6. CHECK (2): HARNESS BETWEEN TRANSFER CONTROL UNIT AND TRANSFER SHIFT RELAY

1. Turn ignition switch "OFF". (Stay for at least 5 seconds.)
2. Disconnect transfer control unit harness connector.
3. Remove transfer shift high relay and transfer shift low relay.
4. Check continuity between the following terminals.
 - Transfer control unit harness connector M153 terminal 28 and transfer shift high relay harness connector E46 terminal 5.
 - Transfer control unit harness connector M153 terminal 28 and transfer shift low relay harness connector E47 terminal 5.
 - Transfer control unit harness connector M153 terminal 31 and transfer shift high relay harness connector E46 terminal 4.
 - Transfer control unit harness connector M153 terminal 31 and transfer shift low relay harness connector E47 terminal 4.

Continuity should exist.

Also check harness for short to ground and short to power.

OK or NG

- OK >> GO TO 7.
- NG >> Repair or replace damaged parts.

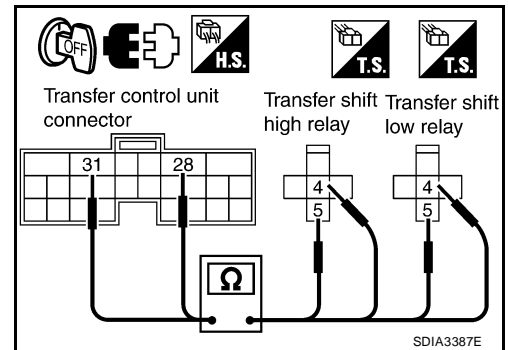

TROUBLE DIAGNOSIS FOR SYSTEM

7. CHECK ACTUATOR MOTOR OPERATION CIRCUIT

- Turn ignition switch "OFF". (Stay for at least 5 seconds.)
- Disconnect transfer control unit harness connector and the transfer control device (actuator motor) harness connector.
- Check continuity between the following terminals.
 - Transfer control unit harness connector M153 terminal 47 and transfer control device (actuator motor) harness connector F58 terminal 23.
 - Transfer control unit harness connector M153 terminal 48 and transfer control device (actuator motor) harness connector F58 terminal 24.

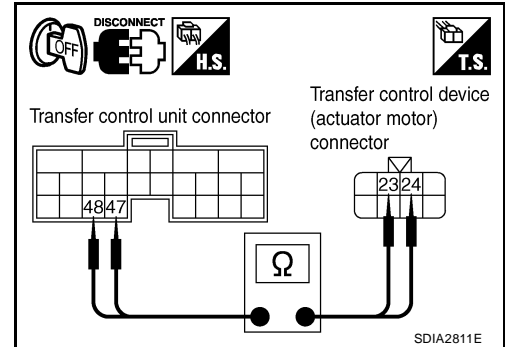

- Transfer control device (actuator motor) harness connector F58 terminal 24 and transfer shift high relay harness connector E46 terminal 3.
- Transfer control device (actuator motor) harness connector F58 terminal 23 and transfer shift low relay harness connector E47 terminal 3.

Continuity should exist.

Also check harness for short to ground and short to power.

OK or NG

- OK >> GO TO 8.
- NG >> Repair or replace damaged parts.

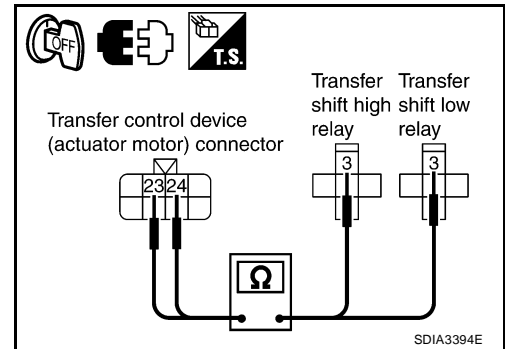

8. CHECK ACTUATOR MOTOR

- Remove transfer control device. Refer to [TF-107, "Removal and Installation"](#).
- Check operation by applying battery voltage to transfer control device (actuator motor) terminals 23 and 24.

CAUTION:
Be careful not to overheat the harness.

Terminal	Actuator motor
24 (Battery voltage) - 23 (Ground)	Clockwise rotate
23 (Battery voltage) - 24 (Ground)	Counterclockwise rotate

Does actuator motor rotate?

- YES >> GO TO 9.
- NO >> Replace transfer control device (actuator motor). Refer to [TF-107, "Removal and Installation"](#).

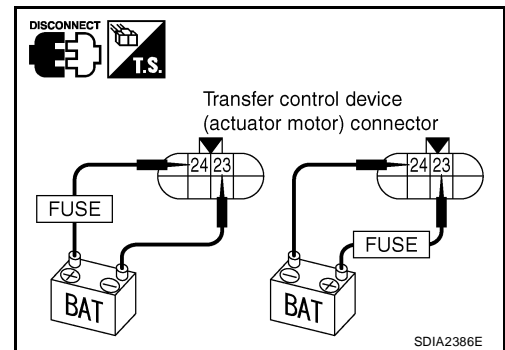

9. CHECK TRANSFER CONTROL UNIT

Check transfer control unit input/output signal. Refer to [TF-37, "Transfer Control Unit Input/Output Signal Reference Values"](#).

OK or NG

- OK >> GO TO 10.
- NG >> Check transfer control unit pin terminals for damage or loose connection with harness connector. If any items are damaged, repair or replace damaged parts.

TROUBLE DIAGNOSIS FOR SYSTEM

10. CHECK DTC

Perform the self-diagnosis, after driving a vehicle for a while.

OK or NG

OK >> Inspection End.

NG >> Replace transfer control unit. Refer to [TF-102, "Removal and Installation"](#) .

COMPONENT INSPECTION

Actuator Motor

1. Remove transfer control device. Refer to [TF-107, "Removal and Installation"](#) .
2. Check operation by applying battery voltage to transfer control device (actuator motor) terminals 23 and 24.

CAUTION:

Be careful not to overheat the harness.

Terminal	Actuator motor
24 (Battery voltage) - 23 (Ground)	Clockwise rotate
23 (Battery voltage) - 24 (Ground)	Counterclockwise rotate

3. If NG, replace transfer control device (actuator motor). Refer to [TF-107, "Removal and Installation"](#) .

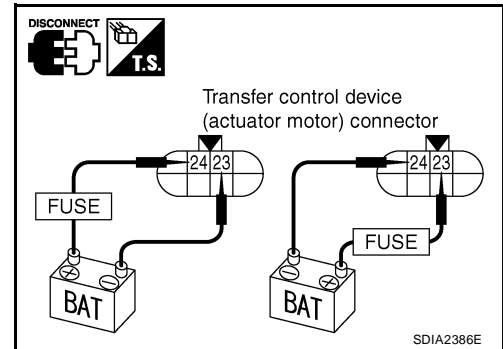

Transfer Relay

1. Turn ignition switch "OFF". (Stay for at least 5 seconds.)
2. Remove transfer shift high relay and transfer shift low relay. Refer to [TF-21, "Location of Electrical Parts"](#) .
3. Apply 12V direct current between transfer shift high and low relay terminals 1 and 2.
4. Check continuity between relay terminals 3 and 4, and 3 and 5.

Terminal	Condition	Continuity
3 - 4	12V direct current supply between terminals 1 and 2	No
	OFF	Yes
3 - 5	12V direct current supply between terminals 1 and 2	Yes
	OFF	No

5. If NG, replace transfer shift high or low relay. Refer to [TF-21, "Location of Electrical Parts"](#) .

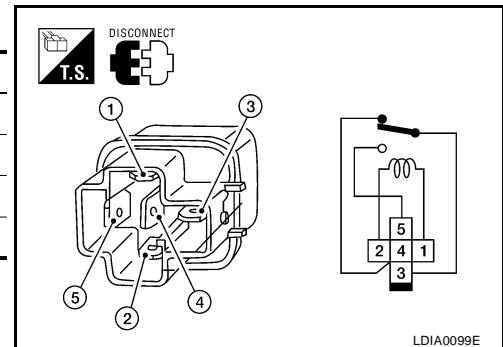

TROUBLE DIAGNOSIS FOR SYSTEM

EDS002Y3

Actuator Position Switch

CONSULT-II REFERENCE VALUE IN DATA MONITOR MODE

Data are reference value.

Monitored item [Unit]	Content	Condition	Display value
SHIFT POS SW1 [ON/OFF]	Condition of actuator position switch 1	4WD shift switch: 2WD and 4LO	ON
		4WD shift switch: 4H	OFF
SHIFT POS SW2 [ON/OFF]	Condition of actuator position switch 2	4WD shift switch: 4LO	ON
		4WD shift switch: 2WD and 4H	OFF
SHIFT POS SW3 [ON/OFF]	Condition of actuator position switch 3	4WD shift switch: 2WD and 4H	ON
		4WD shift switch: 4LO	OFF
SHIFT POS SW4 [ON/OFF]	Condition of actuator position switch 4	4WD shift switch: 4H and 4LO	ON
		4WD shift switch: 2WD	OFF

TRANSFER CONTROL UNIT TERMINALS AND REFERENCE VALUE

Data are reference value and are measured between each terminal and ground.

Terminal	Wire color	Item	Condition	Data (Approx.)
10	LG	Actuator position switch 1	4WD shift switch: 2WD and 4LO	0V
			4WD shift switch: 4H	Battery voltage
11	W	Actuator position switch 2	4WD shift switch: 4LO	0V
			4WD shift switch: 2WD and 4H	Battery voltage
12	BR	Actuator position switch 3	4WD shift switch: 2WD and 4H	0V
			4WD shift switch: 4LO	Battery voltage
13	L	Actuator position switch 4	4WD shift switch: 4H and 4LO	0V
			4WD shift switch: 2WD	Battery voltage

CAUTION:

When using a circuit tester to measure voltage for inspection, be sure not to extend forcibly any connector terminals.

TROUBLE DIAGNOSIS FOR SYSTEM

DIAGNOSTIC PROCEDURE

1. CHECK ACTUATOR POSITION SWITCH SIGNAL

④ With CONSULT-II

1. Start engine.
2. Depress brake pedal and stop vehicle.
3. For A/T models, set A/T selector lever to "N" position. For M/T models shift M/T selector lever to neutral.
4. Select "DATA MONITOR" mode for "ALL MODE AWD/4WD" with CONSULT-II.
5. Read out the value of "SHIFT POS SW1", "SHIFT POS SW2", "SHIFT POS SW3", "SHIFT POS SW4".

Monitored item	Condition	Display value
SHIFT POS SW1	4WD shift switch: 2WD and 4LO	ON
	4WD shift switch: 4H	OFF
SHIFT POS SW2	4WD shift switch: 4LO	ON
	4WD shift switch: 2WD and 4H	OFF
SHIFT POS SW3	4WD shift switch: 2WD and 4H	ON
	4WD shift switch: 4LO	OFF
SHIFT POS SW4	4WD shift switch: 4H and 4LO	ON
	4WD shift switch: 2WD	OFF

DATA MONITOR	
MONITOR	NO DTC
SHIFT POS SW1	ON
SHIFT POS SW2	OFF
SHIFT POS SW3	OFF
SHIFT POS SW4	OFF

PDIA0224E

⊗ Without CONSULT-II

1. Start engine.
2. Depress brake pedal and stop vehicle.
3. For A/T models, set A/T selector lever to "N" position. For M/T models shift M/T selector lever to neutral.
4. Check voltage between transfer control unit harness connector terminal and ground.

Connector	Terminal	Condition	Voltage (Approx.)
M152	10 - Ground	4WD shift switch: 2WD and 4LO	0V
		4WD shift switch: 4H	Battery voltage
	11 - Ground	4WD shift switch: 4LO	0V
		4WD shift switch: 2WD and 4H	Battery voltage
	12 - Ground	4WD shift switch: 2WD and 4H	0V
		4WD shift switch: 4LO	Battery voltage
	13 - Ground	4WD shift switch: 4H and 4LO	0V
		4WD shift switch: 2WD	Battery voltage

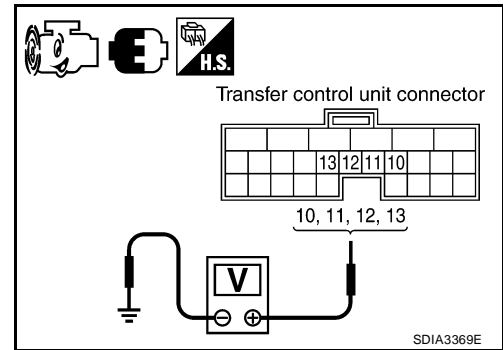

OK or NG

- OK >> GO TO 4.
 NG >> GO TO 2.

TROUBLE DIAGNOSIS FOR SYSTEM

2. CHECK HARNESS BETWEEN TRANSFER CONTROL UNIT AND ACTUATOR POSITION SWITCH

1. Turn ignition switch "OFF". (Stay for at least 5 seconds.)
2. Disconnect transfer control unit harness connector and the transfer control device (actuator position switch) harness connector.
3. Check continuity between the following terminals.
 - Transfer control unit harness connector M152 terminal 10 and transfer control device (actuator position switch) harness connector F58 terminal 26.
 - Transfer control unit harness connector M152 terminal 11 and transfer control device (actuator position switch) harness connector F58 terminal 20.
 - Transfer control unit harness connector M152 terminal 12 and transfer control device (actuator position switch) harness connector F58 terminal 21.
 - Transfer control unit harness connector M152 terminal 13 and transfer control device (actuator position switch) harness connector F58 terminal 25.

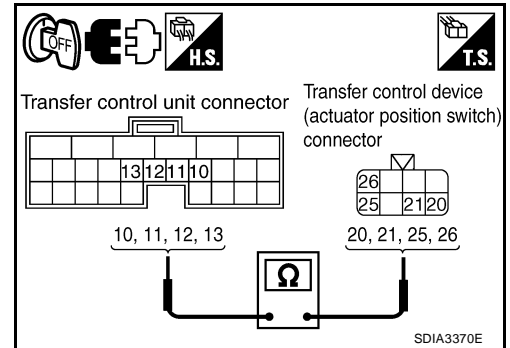

Continuity should exist.

Also check harness for short to ground and short to power.

OK or NG

- OK >> GO TO 3.
- NG >> Repair or replace damaged parts.

3. CHECK GROUND CIRCUIT

1. Turn ignition switch "OFF". (Stay for at least 5 seconds.)
2. Check continuity between transfer control device (actuator position switch) harness connector F58 terminal 22 and ground.

Continuity should exist.

Also check harness for short to power.

OK or NG

- OK >> GO TO 4.
- NG >> Repair open circuit or short to power in harness or connectors.

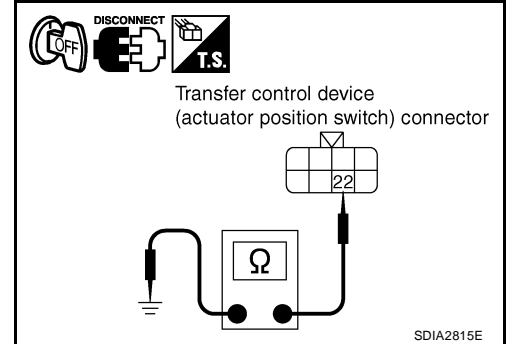

4. CHECK TRANSFER CONTROL UNIT

Check transfer control unit input/output signal. Refer to [TF-37, "Transfer Control Unit Input/Output Signal Reference Values"](#).

OK or NG

- OK >> GO TO 5.
- NG >> Check transfer control unit pin terminals for damage or loose connection with harness connector. If any items are damaged, repair or replace damaged parts.

5. CHECK DTC

Perform the self-diagnosis, after driving a vehicle for a while.

OK or NG

- OK >> Inspection End.
- NG >> Replace transfer control device. Refer to [TF-107, "Removal and Installation"](#).

TROUBLE DIAGNOSIS FOR SYSTEM

Transfer Control Device

EDS002Y4

CONSULT-II REFERENCE VALUE IN DATA MONITOR MODE

Data are reference value.

Monitored item [Unit]	Content	Condition	Display value	
SHIFT ACT/R MON [ON/OFF]	Operating condition of actuator motor relay (integrated in transfer control unit)	<ul style="list-style-type: none"> ● Vehicle stopped ● Engine running ● For A/T models, A/T selector lever "N" position with brake pedal depressed. ● For M/T models, M/T shift lever neutral position with clutch and brake pedal depressed. 	When 4WD shift switch is operated	ON
			When 4WD shift switch is not operated	OFF

TRANSFER CONTROL UNIT TERMINALS AND REFERENCE VALUE

Data are reference value and are measured between each terminal and ground.

Terminal	Wire color	Item	Condition	Data (Approx.)
25	W/G	Ignition switch monitor	Ignition switch: ON	Battery voltage
			Ignition switch: OFF	0V
27	L	Actuator motor power supply	Ignition switch: ON	Battery voltage
			Ignition switch: OFF (5 seconds after ignition switch is turned OFF.)	0V
32	B	Ground	Always	0V
40	V	Transfer shut off relay	Ignition switch: ON	0V
			Ignition switch: OFF (5 seconds after ignition switch is turned OFF.)	Battery voltage

CAUTION:

When using a circuit tester to measure voltage for inspection, be sure not to extend forcibly any connector terminals.

TROUBLE DIAGNOSIS FOR SYSTEM

DIAGNOSTIC PROCEDURE

1. CHECK POWER SUPPLY

1. Turn ignition switch "OFF". (Stay for at least 5 seconds.)
2. Disconnect transfer control unit harness connector.
3. Check voltage between transfer control unit harness connector terminal and ground.

Connector	Terminal	Voltage (Approx.)
M152	25 - Ground	0V
M153	27 - Ground	

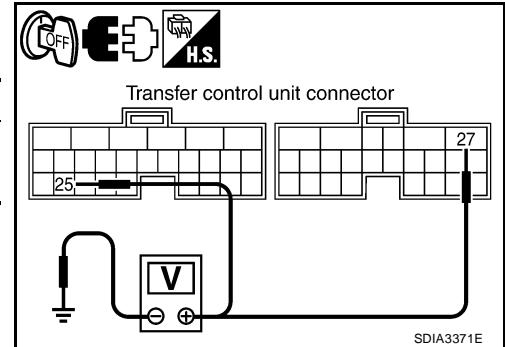

4. Turn ignition switch "ON". (Do not start engine.)
5. Check voltage between transfer control unit harness connector terminals and ground.

Connector	Terminal	Voltage (Approx.)
M152	25 - Ground	Battery voltage
M153	27 - Ground	

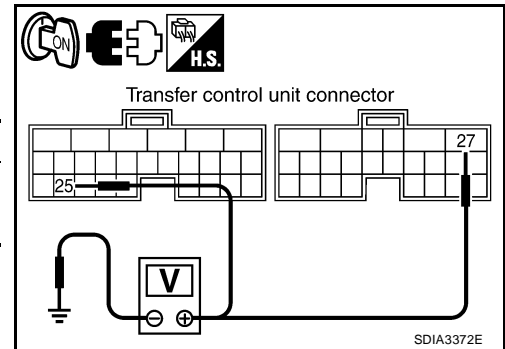

OK or NG

OK >> GO TO 2.

NG >> Check the following. If any items are damaged, repair or replace damaged parts.

- 10A fuse (No. 57, located in the fuse and relay box).
- 40A fusible link (No. j, located in the fuse and fusible link box).
- Harness for short or open between battery and transfer shut off relay 1 harness connector E156 terminal 3.
- Harness for short or open between transfer control unit harness connector M153 terminal 27 and transfer shut off relay 1 harness connector E156 terminal 5.
- Harness for short or open between ignition switch and transfer shut off relay 1 harness connector E156 terminal 1.
- Harness for short or open between transfer shut off relay 1 harness connector E156 terminal 2 and ground.
- Harness for short or open between ignition switch and transfer control unit harness connector M152 terminal 25.
- Battery and ignition switch. Refer to [PG-4, "POWER SUPPLY ROUTING CIRCUIT"](#).
- Transfer shut off relay 1. Refer to [TF-54, "COMPONENT INSPECTION"](#).

TROUBLE DIAGNOSIS FOR SYSTEM

2. CHECK GROUND CIRCUIT

1. Turn ignition switch "OFF".
2. Disconnect transfer control unit harness connector.
3. Check continuity between transfer control unit harness connector M153 terminal 32 and ground.

Continuity should exist.

Also check harness for short to power.

OK or NG

- OK >> GO TO 3.
 NG >> Repair open circuit or short to power in harness or connectors.

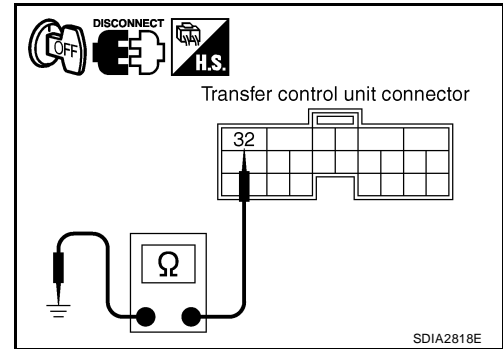

3. CHECK POWER SUPPLY SIGNAL

1. Turn ignition switch "OFF". (Stay for at least 5 seconds.)
2. Connect transfer control unit harness connector.
3. Check voltage between transfer control unit harness connector terminal and ground.

Connector	Terminal	Voltage (Approx.)
M153	40 - Ground	Battery voltage

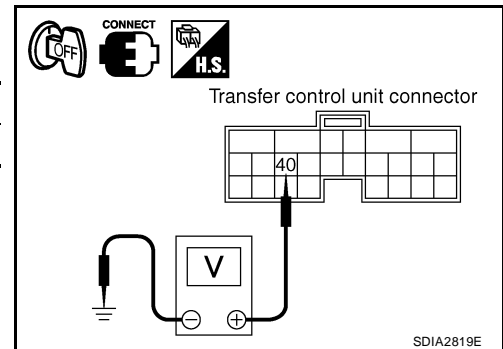

4. Turn ignition switch "ON". (Do not start engine.)
5. Check voltage between transfer control unit harness connector terminal and ground.

Connector	Terminal	Voltage (Approx.)
M153	40 - Ground	0V

OK or NG

- OK >> GO TO 4.
 NG >> Check the following. If any items are damaged, repair or replace damaged parts.
- Harness for short or open between battery and transfer shut off relay 2 harness connector E157 terminal 1.
 - Harness for short or open between transfer shut off relay 2 harness connector E157 terminal 2 and transfer control unit harness connector M153 terminal 40.
 - Transfer shut off relay 2. Refer to [TF-54, "COMPONENT INSPECTION"](#) .

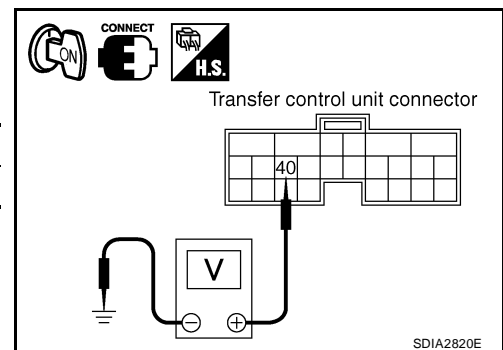

4. CHECK TRANSFER CONTROL UNIT

Check transfer control unit input/output signal. Refer to [TF-37, "Transfer Control Unit Input/Output Signal Reference Values"](#) .

OK or NG

- OK-1 >> With CONSULT-II: GO TO 5.
 OK-2 >> Without CONSULT-II: GO TO 6.
 NG >> Check transfer control unit pin terminals for damage or loose connection with harness connector. If any items are damaged, repair or replace damaged parts.

TROUBLE DIAGNOSIS FOR SYSTEM

5. PERFORM SELF-DIAGNOSIS (WITH CONSULT-II)

With CONSULT-II

1. Turn ignition switch "ON". (Do not start engine.)
2. Select "SELF-DIAG RESULTS" mode for "ALL MODE AWD/4WD" with CONSULT-II.
3. Touch "ERASE".
4. Turn ignition switch "OFF" and wait at least 10 seconds.
5. Perform the self-diagnosis again.

Is the "SHIFT ACT CIR [P1819]" displayed?

- YES >> Replace transfer control unit. Refer to [TF-102, "Removal and Installation"](#) .
- NO >> Inspection End.

6. PERFORM SELF-DIAGNOSIS (WITHOUT CONSULT-II)

Without CONSULT-II

1. Perform the self-diagnosis and then erase self-diagnostic results. Refer to [TF-47, "SELF-DIAGNOSTIC PROCEDURE \(WITHOUT CONSULT-II\)"](#) and [TF-50, "ERASE SELF-DIAGNOSIS"](#) .
2. Perform the self-diagnosis again.

Do the self-diagnostic results indicate transfer control device?

- YES >> Replace transfer control unit. Refer to [TF-102, "Removal and Installation"](#) .
- NO >> Inspection End.

Engine Speed Signal DIAGNOSTIC PROCEDURE

EDS002Y5

1. CHECK DTC WITH ECM

Perform self-diagnosis with ECM. Refer to [EC-117, "SELF-DIAG RESULTS MODE"](#) .

Is any malfunction detected by self-diagnosis?

- YES >> Check the malfunctioning system.
- NO >> GO TO 2.

2. CHECK TRANSFER CONTROL UNIT

Check transfer control unit input/output signal. Refer to [TF-37, "Transfer Control Unit Input/Output Signal Reference Values"](#) .

OK or NG

- OK >> GO TO 3.
- NG >> Check transfer control unit pin terminals for damage or loose connection with harness connector. If any items are damaged, repair or replace damaged parts.

3. CHECK DTC

Perform the self-diagnosis, after driving a vehicle for a while.

OK or NG

- OK >> Inspection End.
- NG >> Perform self-diagnosis with ECM again. Refer to [EC-117, "SELF-DIAG RESULTS MODE"](#) .

TROUBLE DIAGNOSIS FOR SYSTEM

EDS002Y6

CAN Communication Line DIAGNOSTIC PROCEDURE

1. CHECK CAN COMMUNICATION CIRCUIT

Ⓟ **With CONSULT-II**

1. Turn ignition switch "ON" and start engine.
2. Select "SELF-DIAG RESULTS" mode for "ALL MODE AWD/4WD" with in CONSULT-II.
3. Perform the self-diagnosis.

Is the "CAN COMM CIRCUIT [U1000]" displayed?

- YES >> Print out CONSULT-II screen and go to [LAN-3, "Precautions When Using CONSULT-II"](#) .
- NO >> Inspection End.

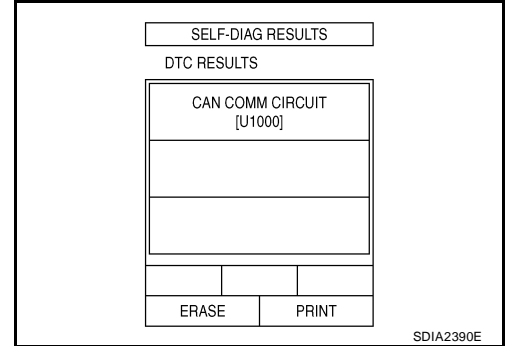

ATP Switch

CONSULT-II REFERENCE VALUE IN DATA MONITOR MODE

EDS002Y7

Data are reference value.

Monitored item [Unit]	Content	Condition	Display value
ATP SWITCH [ON/OFF]	Condition of ATP switch	<ul style="list-style-type: none"> ● Vehicle stopped ● Engine running ● A/T selector lever "N" position with brake pedal depressed. 	4WD shift switch : 4H to 4LO or 4LO to 4H (While actuator motor is operating.)
		Except the above	OFF

TRANSFER CONTROL UNIT TERMINALS AND REFERENCE VALUE

Data are reference value and are measured between each terminal and ground.

Terminal	Wire color	Item	Condition	Data (Approx.)
23	R	ATP switch	<ul style="list-style-type: none"> ● Vehicle stopped ● Engine running ● A/T selector lever "N" position with brake pedal depressed. 	4WD shift switch : 4H to 4LO or 4LO to 4H (While actuator motor is operating.)
			Except the above	Battery voltage

CAUTION:

When using a circuit tester to measure voltage for inspection, be sure not to extend forcibly any connector terminals.

TROUBLE DIAGNOSIS FOR SYSTEM

DIAGNOSTIC PROCEDURE

1. CHECK ATP SWITCH SIGNAL

☑ With CONSULT-II

1. Start engine.
2. Select "DATA MONITOR" mode for "ALL MODE AWD/4WD" with CONSULT-II.
3. Read out the value of "ATP SWITCH".

Condition		Display value
<ul style="list-style-type: none"> ● Vehicle stopped ● Engine running 	4WD shift switch: 4H to 4LO or 4LO to 4H (While actuator motor is operating.)	ON
<ul style="list-style-type: none"> ● A/T selector lever "N" position with brake pedal depressed. 	Except the above	OFF

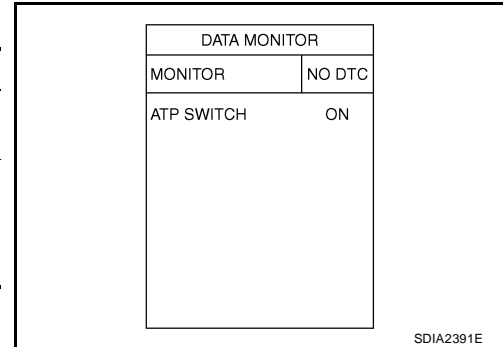

☒ Without CONSULT-II

1. Start engine.
2. Check voltage between transfer control unit harness connector terminal and ground.

Connector	Terminal	Condition	Voltage (Approx.)
M152	23 - Ground	<ul style="list-style-type: none"> ● Vehicle stopped ● Engine running 	4WD shift switch: 4H to 4LO or 4LO to 4H (While actuator motor is operating.)
		<ul style="list-style-type: none"> ● A/T selector lever "N" position with brake pedal depressed. 	Except the above
			Battery voltage

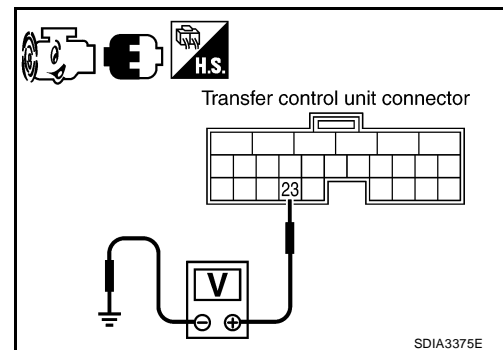

OK or NG

- OK >> GO TO 5.
 NG >> GO TO 2.

2. CHECK HARNESS BETWEEN TRANSFER CONTROL UNIT AND ATP SWITCH

1. Turn ignition switch "OFF". (Stay for at least 5 seconds.)
2. Disconnect transfer control unit harness connector and the ATP switch harness connector.
3. Check continuity between transfer control unit harness connector M152 terminal 23 and ATP switch harness connector F55 terminal 8.

Continuity should exist.

Also check harness for short to ground and short to power.

OK or NG

- OK >> GO TO 3.
 NG >> Repair or replace damaged parts.

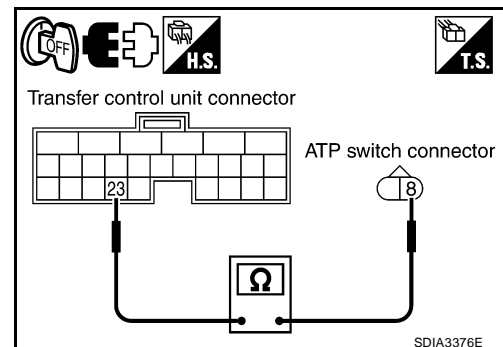

TROUBLE DIAGNOSIS FOR SYSTEM

3. CHECK GROUND CIRCUIT

1. Turn ignition switch "OFF". (Stay for at least 5 seconds.)
2. Disconnect ATP switch harness connector.
3. Check continuity between ATP switch harness connector F55 terminal 9 and ground.

Continuity should exist.

Also check harness for short to power.

OK or NG

OK >> GO TO 4.

NG >> Repair open circuit or short to power in harness or connectors.

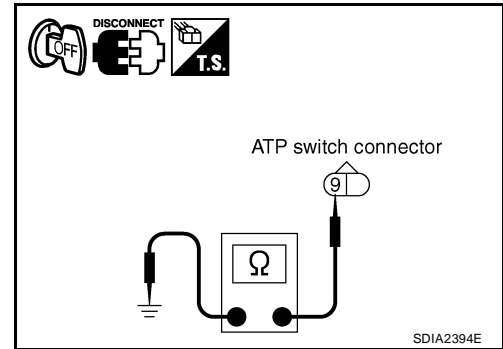

4. CHECK ATP SWITCH

1. Turn ignition switch "OFF". (Stay for at least 5 seconds.)
2. Remove ATP switch. Refer to [TF-21, "Location of Electrical Parts"](#).
3. Push and release ATP switch and check continuity between ATP switch terminals 8 and 9.

Terminal	Condition	Continuity
8 - 9	Push ATP switch	Yes
	Release ATP switch	No

OK or NG

OK >> GO TO 5.

NG >> Replace ATP switch. Refer to [TF-21, "Location of Electrical Parts"](#).

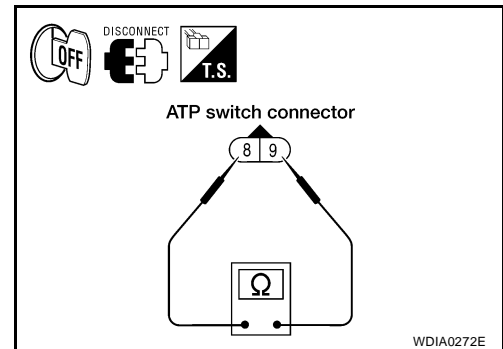

5. CHECK TRANSFER CONTROL UNIT

Check transfer control unit input/output signal. Refer to [TF-37, "Transfer Control Unit Input/Output Signal Reference Values"](#).

OK or NG

OK >> GO TO 6.

NG >> Check transfer control unit pin terminals for damage or loose connection with harness connector. If any items are damaged, repair or replace damaged parts.

6. CHECK ATP WARNING LAMP

1. Turn ignition switch "ON". (Do not start engine.)
2. A/T selector lever "N" position and engage the parking brake.
3. Switch 4WD shift switch from 4H to 4LO or 4LO to 4H.

Does ATP warning lamp turn "ON", while actuator motor is operating?

YES >> Inspection End.

NO >> Go to [TF-98, "ATP Warning Lamp Does Not Turn ON"](#).

TROUBLE DIAGNOSIS FOR SYSTEM

COMPONENT INSPECTION

1. Turn ignition switch "OFF". (Stay for at least 5 seconds.)
2. Disconnect ATP switch harness connector.
3. Remove ATP switch. Refer to [TF-21, "Location of Electrical Parts"](#) .
4. Push and release ATP switch and check continuity between ATP switch terminals 8 and 9.

Terminal	Condition	Continuity
8 - 9	Push ATP switch	Yes
	Release ATP switch	No

5. If NG, replace the ATP switch. Refer to [TF-21, "Location of Electrical Parts"](#) .

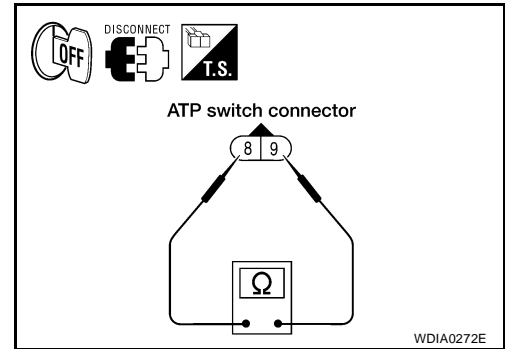

Park/Neutral Position Switch (M/T Models) TRANSFER CONTROL UNIT TERMINALS AND REFERENCE VALUE

EDS002Y8

Data are reference value and are measured between each terminal and ground.

Terminal	Wire color	Item	Condition	Data (Approx.)	
33	P	Park/neutral position switch	Ignition switch: ON	M/T shift lever neutral position	0V
				Except the above	Battery voltage

CAUTION:

When using a circuit tester to measure voltage for inspection, be sure not to extend forcibly any connector terminals.

DIAGNOSTIC PROCEDURE

1. CHECK PARK/NEUTRAL POSITION SWITCH SIGNAL

⊗ Without CONSULT-II

1. Turn ignition switch "ON".
2. Check voltage between transfer control unit harness connector M152 terminal 33 and ground.

Connector	Terminal	Condition	Voltage (Approx.)	
M152	33 - Ground	Ignition switch: ON	M/T shift lever neutral position	0V
			Except the above	Battery voltage

OK or NG

- OK >> GO TO 5.
NG >> GO TO 2.

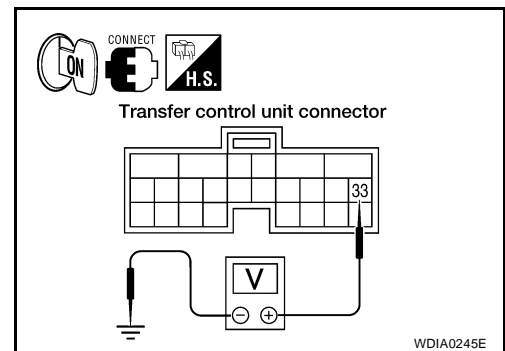

TROUBLE DIAGNOSIS FOR SYSTEM

2. CHECK HARNESS BETWEEN TRANSFER CONTROL UNIT AND PARK/NEUTRAL POSITION SWITCH

1. Turn ignition switch "OFF". (Stay for at least 5 seconds.)
2. Disconnect transfer control unit harness connector and the park/neutral position switch harness connector.
3. Check continuity between transfer control unit harness connector M152 terminal 33 and park/neutral position switch harness connector F66 terminal 1.

Continuity should exist.

Also check harness for short to ground and short to power.

OK or NG

- OK >> GO TO 3.
 NG >> Repair or replace damaged parts.

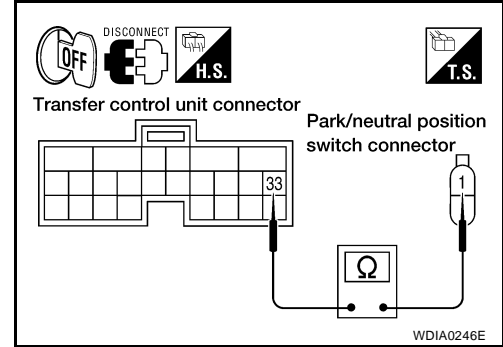

3. CHECK GROUND CIRCUIT

1. Turn ignition switch "OFF". (Stay for at least 5 seconds.)
2. Disconnect park/neutral position switch harness connector.
3. Check continuity between park/neutral position switch harness connector F66 terminal 2 and ground.

Continuity should exist.

Also check harness for short to power.

OK or NG

- OK >> GO TO 4.
 NG >> Repair open circuit or short to power in harness or connectors.

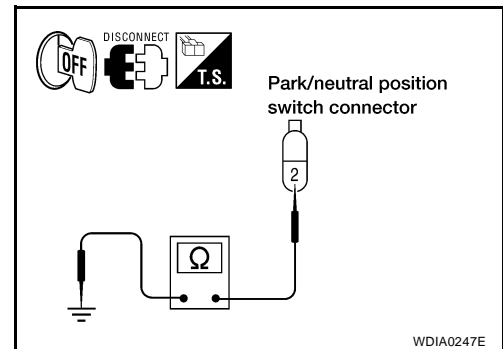

4. CHECK PARK/NEUTRAL POSITION SWITCH

1. Turn ignition switch "OFF". (Stay for at least 5 seconds.)
2. Remove park/neutral position switch. Refer to [TF-21, "Location of Electrical Parts"](#) .
3. Push and release park/neutral position switch and check continuity between park/neutral position switch terminals 1 and 2.

Terminal	Condition	Continuity
1 - 2	Push park/neutral position switch	Yes
	Release park/neutral position switch	No

OK or NG

- OK >> GO TO 5.
 NG >> Replace park/neutral position switch. Refer to [TF-21, "Location of Electrical Parts"](#) .

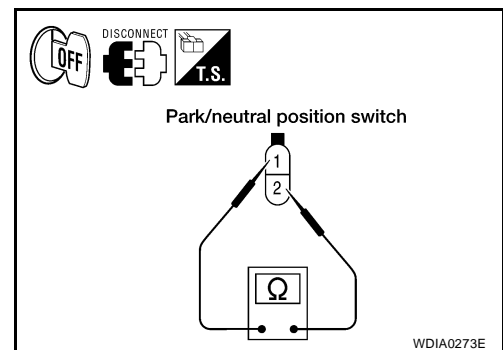

TROUBLE DIAGNOSIS FOR SYSTEM

5. CHECK TRANSFER CONTROL UNIT

Check transfer control unit input/output signal. Refer to [TF-37, "Transfer Control Unit Input/Output Signal Reference Values"](#) .

OK or NG

- OK >> Inspection End.
- NG >> Check transfer control unit pin terminals for damage or loose connection with harness connector.
If any items are damaged, repair or replace damaged parts.

COMPONENT INSPECTION

1. Turn ignition switch "OFF". (Stay for at least 5 seconds.)
2. Disconnect neutral position switch harness connector.
3. Remove neutral position switch. Refer to [TF-21, "Location of Electrical Parts"](#) .
4. Push and release neutral position switch and check continuity between neutral position switch terminals 1 and 2.

Terminal	Condition	Continuity
1 - 2	Push neutral position switch	Yes
	Release neutral position switch	No

5. If NG, replace the neutral position switch. Refer to [TF-21, "Location of Electrical Parts"](#) .

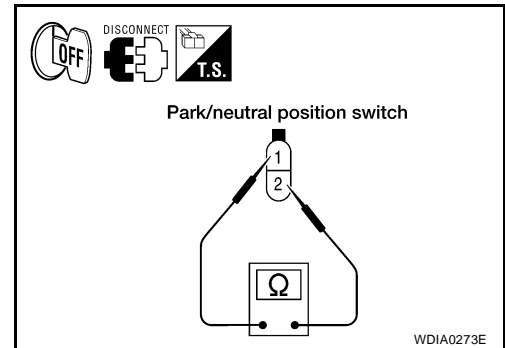

TROUBLE DIAGNOSIS FOR SYMPTOMS

TROUBLE DIAGNOSIS FOR SYMPTOMS

PF0:00007

4WD Shift Indicator Lamp and 4LO Indicator Lamp Do Not Turn ON

EDS002Y9

SYMPTOM:

4WD shift indicator lamp and 4LO indicator lamp do not turn ON for approx. 1 second when turning ignition switch to "ON".

TROUBLE DIAGNOSIS FOR SYMPTOMS

DIAGNOSTIC PROCEDURE

1. CHECK TRANSFER CONTROL UNIT POWER SUPPLY CIRCUIT

1. Turn ignition switch "OFF". (Stay for at least 5 seconds.)
2. Disconnect transfer control unit harness connector.
3. Check voltage between transfer control unit harness connector terminals and ground.

Connector	Terminal	Voltage (Approx.)
M152	19 - Ground	Battery voltage
	25 - Ground	0V
M153	40 - Ground	Battery voltage
	44 - Ground	0V
	45 - Ground	

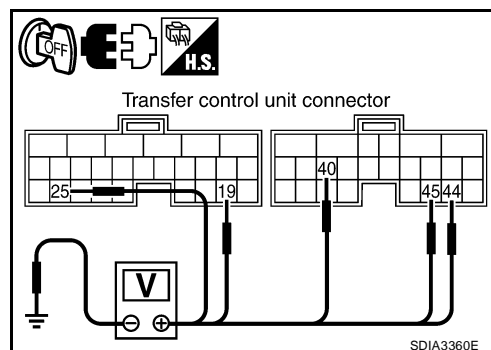

4. Turn ignition switch "ON". (Do not start engine.)
5. Check voltage between transfer control unit harness connector terminals and ground.

Connector	Terminal	Voltage (Approx.)
M152	19 - Ground	Battery voltage
	25 - Ground	
M153	40 - Ground	
	44 - Ground	
	45 - Ground	

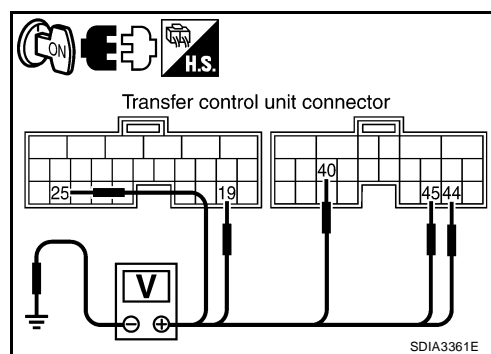

OK or NG

OK >> GO TO 2.

NG >> Check the following. If any items are damaged, repair or replace damaged parts.

- 40A fusible link (No. j , located in the fuse and fusible link box). Refer to [PG-4, "POWER SUPPLY ROUTING CIRCUIT"](#) .
- 10A fuses [No. 21, located in the fuse block (J/B) and Nos. 57 and 58 located in the fuse and relay box]. Refer to [PG-4, "POWER SUPPLY ROUTING CIRCUIT"](#) .
- Harness for short or open between battery and transfer control unit harness connector M152 terminal 19.
- Harness for short or open between battery and transfer shut off relay 2 harness connector E157 terminal 1 and 3.
- Harness for short or open between battery and transfer shut off relay 1 harness connector E156 terminal 3.
- Harness for short or open between ignition switch and transfer control unit harness connector M152 terminal 25.
- Harness for short or open between ignition switch and transfer shut off relay 1 harness connector E156 terminal 1.
- Harness for short or open between transfer shut off relay 2 harness connector E157 terminal 5 and transfer control unit harness connector M153 terminals 44, 45.
- Harness for short or open between transfer shut off relay 1 harness connector E156 terminal 5 and transfer control unit harness connector M153 terminals 44, 45.
- Harness for short or open between transfer shut off relay 2 harness connector E157 terminal 2 and transfer control unit harness connector M153 terminal 40.
- Harness for open between transfer shut off relay 1 harness connector E156 terminal 2 and ground.
- Battery and ignition switch. Refer to [PG-4, "POWER SUPPLY ROUTING CIRCUIT"](#) .
- Transfer shut off relay 1, 2. Refer to [TF-54, "COMPONENT INSPECTION"](#) .

TROUBLE DIAGNOSIS FOR SYMPTOMS

2. CHECK TRANSFER CONTROL UNIT GROUND CIRCUIT

1. Turn ignition switch "OFF". (Stay for at least 5 seconds.)
2. Disconnect transfer control unit harness connectors.
3. Check continuity between transfer control unit harness connector M152 terminals 6, 18, M153 terminal 32 and ground.

Continuity should exist.

Also check harness for short to power.

OK or NG

- OK >> GO TO 3.
 NG >> Repair open circuit or short to power in harness or connectors.

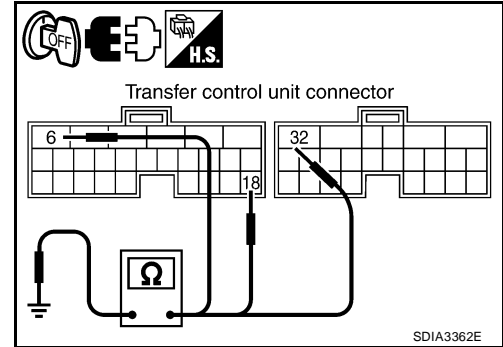

3. CHECK COMBINATION METER POWER SUPPLY CIRCUIT

1. Turn ignition switch "OFF". (Stay for at least 5 seconds.)
2. Disconnect combination meter harness connector.
3. Check voltage between combination meter harness connector M24 terminal 16 and ground.

Connector	Terminal	Voltage (Approx.)
M24	16 - Ground	0V

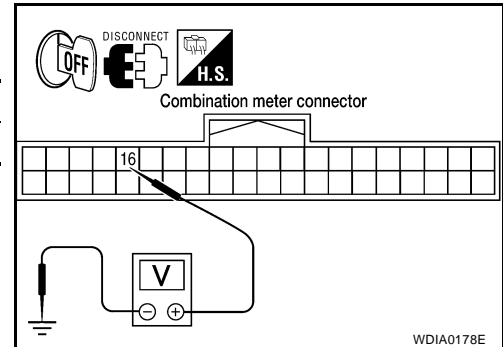

4. Turn ignition switch "ON". (Do not start engine.)
5. Check voltage between combination meter harness connector M24 terminal 16 and ground.

Connector	Terminal	Voltage (Approx.)
M24	16 - Ground	Battery voltage

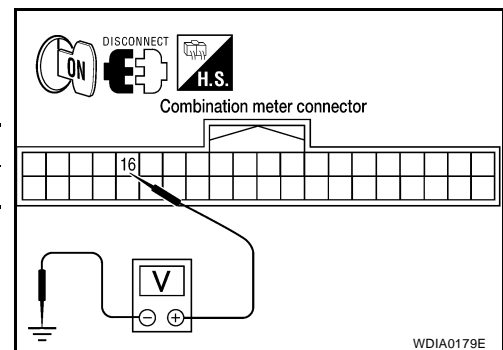

OK or NG

- OK >> GO TO 4.
 NG >> Check the following. If any items are damaged, repair or replace damaged parts.
- 10A fuse [No. 14, located in the fuse block (J/B) or] ignition switch.
 - Harness for short or open between ignition switch and combination meter harness connector M24 terminal 16

TROUBLE DIAGNOSIS FOR SYMPTOMS

4. CHECK HARNESS BETWEEN TRANSFER CONTROL UNIT AND COMBINATION METER

1. Turn ignition switch "OFF". (Stay for at least 5 seconds.)
2. Check continuity between the following terminals.
 - Transfer control unit harness connector M153 terminal 35 and combination meter harness connector M24 terminal 30.
 - Transfer control unit harness connector M153 terminal 36 and combination meter harness connector M24 terminal 27.
 - Transfer control unit harness connector M153 terminal 37 and combination meter harness connector M24 terminal 29.

Continuity should exist.

Also check harness for short to ground and short to power.

OK or NG

OK >> GO TO 5.

NG >> Repair or replace damaged parts.

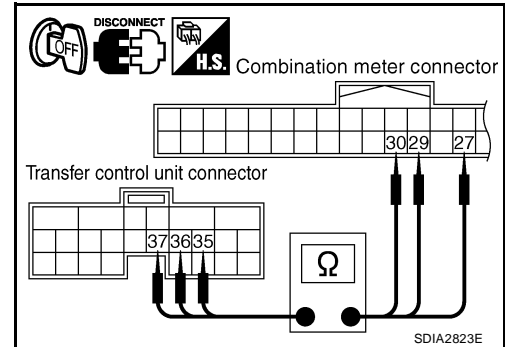

5. CHECK INDICATOR LAMP CIRCUIT

1. Turn ignition switch "OFF". (Stay for at least 5 seconds.)
2. Connect combination meter harness connector.
3. Disconnect transfer control unit harness connector.
4. Turn ignition switch "ON". (Do not start engine.)
5. Ground the following terminals using suitable wiring.
 - Transfer control unit harness connector M153 terminal 35 and ground.
 - Transfer control unit harness connector M153 terminal 36 and ground.
 - Transfer control unit harness connector M153 terminal 37 and ground.

Do indicator lamps turn on?

OK >> GO TO 6.

NG >> Replace the combination meter. Refer to [IP-13, "COMBINATION METER"](#) .

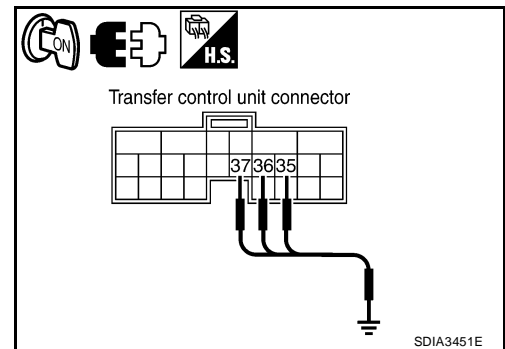

6. SYMPTOM CHECK

Check again.

OK or NG

OK >> Inspection End.

NG >> GO TO 7.

7. CHECK TRANSFER CONTROL UNIT

Check transfer control unit input/output signal. Refer to [TF-37, "Transfer Control Unit Input/Output Signal Reference Values"](#) .

OK or NG

OK >> Inspection End.

NG >> Check transfer control unit pin terminals for damage or loose connection with harness connector. If any items are damaged, repair or replace damaged parts.

4WD Warning Lamp Does Not Turn ON

SYMPTOM:

4WD warning lamp does not turn ON when turning ignition switch to "ON".

EDS002YA

TROUBLE DIAGNOSIS FOR SYMPTOMS

DIAGNOSTIC PROCEDURE

1. CHECK TRANSFER CONTROL UNIT POWER SUPPLY CIRCUIT

1. Turn ignition switch "OFF". (Stay for at least 5 seconds.)
2. Disconnect transfer control unit harness connector.
3. Check voltage between transfer control unit harness connector terminals and ground.

Connector	Terminal	Voltage (Approx.)
M152	19 - Ground	Battery voltage
	25 - Ground	0V
M153	40 - Ground	Battery voltage
	44 - Ground	0V
	45 - Ground	

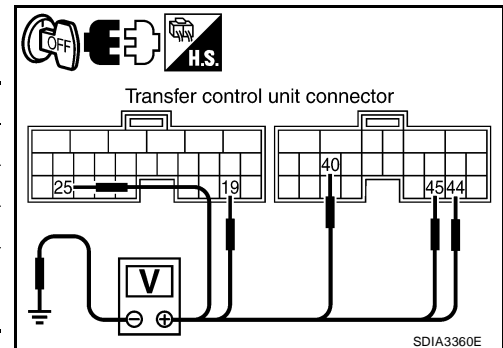

4. Turn ignition switch "ON". (Do not start engine.)
5. Check voltage between transfer control unit harness connector terminals and ground.

Connector	Terminal	Voltage (Approx.)
M152	19 - Ground	Battery voltage
	25 - Ground	
M153	40 - Ground	
	44 - Ground	
	45 - Ground	

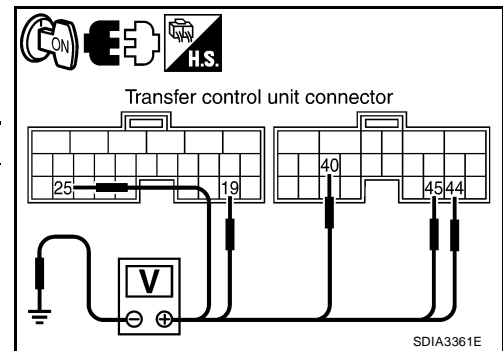

OK or NG

OK >> GO TO 2.

NG >> Check the following. If any items are damaged, repair or replace damaged parts.

- 40A fusible link (No. j , located in the fuse and fusible link box). Refer to [PG-4, "POWER SUPPLY ROUTING CIRCUIT"](#) .
- 10A fuses [No. 21, located in the fuse block (J/B) and Nos. 57 and 58 located in the fuse and relay box]. Refer to [PG-4, "POWER SUPPLY ROUTING CIRCUIT"](#) .
- Harness for short or open between battery and transfer control unit harness connector M152 terminal 19.
- Harness for short or open between battery and transfer shut off relay 2 harness connector E157 terminal 1 and 3.
- Harness for short or open between battery and transfer shut off relay 1 harness connector E156 terminal 3.
- Harness for short or open between ignition switch and transfer control unit harness connector M152 terminal 25.
- Harness for short or open between ignition switch and transfer shut off relay 1 harness connector E156 terminal 1.
- Harness for short or open between transfer shut off relay 2 harness connector E157 terminal 5 and transfer control unit harness connector M153 terminals 44, 45.
- Harness for short or open between transfer shut off relay 1 harness connector E156 terminal 5 and transfer control unit harness connector M153 terminals 44, 45.
- Harness for short or open between transfer shut off relay 2 harness connector E157 terminal 2 and transfer control unit harness connector M153 terminal 40.
- Harness for open between transfer shut off relay 1 harness connector E156 terminal 2 and ground.
- Battery and ignition switch. Refer to [PG-4, "POWER SUPPLY ROUTING CIRCUIT"](#) .
- Transfer shut off relay 1, 2. Refer to [TF-54, "COMPONENT INSPECTION"](#) .

TROUBLE DIAGNOSIS FOR SYMPTOMS

2. CHECK TRANSFER CONTROL UNIT GROUND CIRCUIT

1. Turn ignition switch "OFF". (Stay for at least 5 seconds.)
2. Disconnect transfer control unit harness connector.
3. Check continuity between transfer control unit harness connector M152 terminals 6, 18, M153 terminal 32 and ground.

Continuity should exist.

Also check harness for short to power.

OK or NG

OK >> GO TO 3.

NG >> Repair open circuit or short to power in harness or connectors.

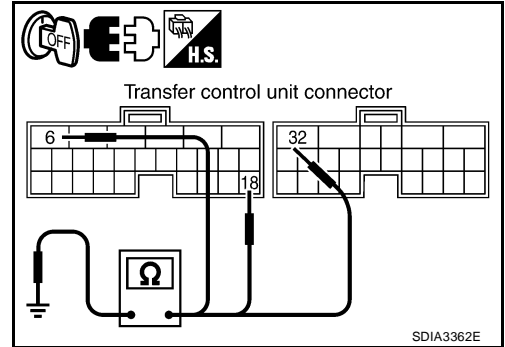

3. CHECK COMBINATION METER POWER SUPPLY CIRCUIT

1. Turn ignition switch "OFF". (Stay for at least 5 seconds.)
2. Disconnect combination meter harness connector.
3. Check voltage between combination meter harness connector terminals and ground.

Connector	Terminal	Voltage (Approx.)
M24	16 - Ground	0V

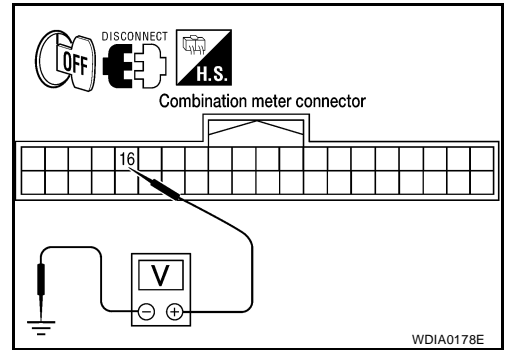

4. Turn ignition switch "ON". (Do not start engine.)
5. Check voltage between combination meter harness connector terminals and ground.

Connector	Terminal	Voltage (Approx.)
M24	16 - Ground	Battery voltage

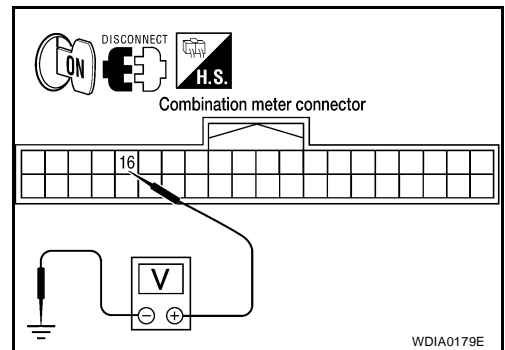

OK or NG

OK >> GO TO 4.

NG >> Check the following. If any items are damaged, repair or replace damaged parts.

- 10A fuse [No. 14, located in the fuse block (J/B)] or ignition switch.
- Harness for short or open between ignition switch and combination meter harness connector M24 terminal 16

TROUBLE DIAGNOSIS FOR SYMPTOMS

4. CHECK HARNESS BETWEEN TRANSFER CONTROL UNIT AND COMBINATION METER

1. Turn ignition switch "OFF". (Stay for at least 5 seconds.)
2. Check continuity between transfer control unit harness connector M153 terminal 38 and combination meter harness connector M24 terminal 26.

Continuity should exist.

Also check harness for short to ground and short to power.

OK or NG

- OK >> GO TO 5.
- NG >> Repair or replace damaged parts.

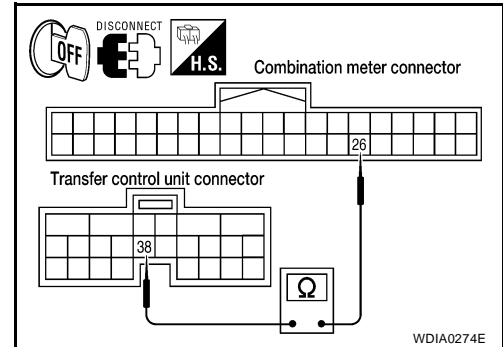

5. CHECK INDICATOR LAMP CIRCUIT

1. Turn ignition switch "OFF". (Stay for at least 5 seconds.)
2. Connect combination meter harness connector.
3. Disconnect transfer control unit harness connector.
4. Turn ignition switch "ON". (Do not start engine.)
5. Ground the following terminal using suitable wiring.
 - Transfer control unit harness connector M153 terminal 38 and ground.

Does the indicator lamp turn on?

- OK >> GO TO 6.
- NG >> Replace the combination meter. Refer to [IP-13, "COMBINATION METER"](#) .

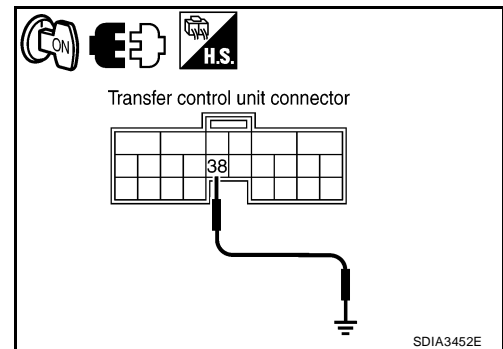

6. SYMPTOM CHECK

Check again.

OK or NG

- OK >> Inspection End.
- NG >> GO TO 7.

7. CHECK TRANSFER CONTROL UNIT

Check transfer control unit input/output signal. Refer to [TF-37, "Transfer Control Unit Input/Output Signal Reference Values"](#) .

OK or NG

- OK >> Inspection End.
- NG >> Check transfer control unit pin terminals for damage or loose connection with harness connector. If any items are damaged, repair or replace damaged parts.

4WD Shift Indicator Lamp or 4LO Indicator Lamp Do Not Change

EDS002YB

SYMPTOM:

4WD shift indicator lamp or 4LO indicator lamp do not change when switching 4WD shift switch.

TROUBLE DIAGNOSIS FOR SYMPTOMS

DIAGNOSTIC PROCEDURE

1. CONFIRM THE SYMPTOM

Confirm 4WD shift indicator lamp and 4LO indicator lamp turn on when ignition switch is turned to ON.
Do 4WD shift indicator lamp and 4LO indicator lamp turn on?

YES - 1 (A/T models)>>GO TO 2.

YES - 2 (M/T models)>>GO TO 3.

NO >> Go to [TF-90, "4WD Shift Indicator Lamp and 4LO Indicator Lamp Do Not Turn ON"](#) .

2. CHECK SYSTEM FOR STOP LAMP SWITCH

Perform trouble diagnosis for stop lamp switch system. Refer to [BRC-46, "Stop Lamp Switch System Inspection" \(VDC/TCS/ABS\)](#) or [BRC-110, "Stop Lamp Switch System Inspection" \(HDC/HSA/VDC/TCS/ABS\)](#).

OK or NG

OK >> GO TO 3.

NG >> Repair or replace damaged parts.

3. CHECK SYSTEM FOR 4WD SHIFT SWITCH

Perform trouble diagnosis for 4WD shift switch system. Refer to [TF-59, "4WD Shift Switch"](#) .

OK or NG

OK >> GO TO 4.

NG >> Repair or replace damaged parts.

4. CHECK SYSTEM FOR WAIT DETECTION SWITCH

Perform trouble diagnosis for wait detection switch system. Refer to [TF-63, "Wait Detection Switch"](#) .

OK or NG

OK >> GO TO 5.

NG >> Repair or replace damaged parts.

5. CHECK SYSTEM FOR 4LO SWITCH

Perform trouble diagnosis for 4LO switch system. Refer to [TF-56, "4LO Switch"](#) .

OK or NG

OK (A/T models) >>GO TO 6.

OK (M/T models) >>GO TO 7.

NG >> Repair or replace damaged parts.

6. CHECK SYSTEM FOR ATP SWITCH

Perform trouble diagnosis for ATP switch system. Refer to [TF-84, "ATP Switch"](#) .

OK or NG

OK >> GO TO 7.

NG >> Repair or replace damaged parts.

7. SYMPTOM CHECK

Check again.

OK or NG

OK >> Inspection End.

NG >> GO TO 8.

TROUBLE DIAGNOSIS FOR SYMPTOMS

8. CHECK TRANSFER CONTROL UNIT

Check transfer control unit input/output signal. Refer to [TF-37, "Transfer Control Unit Input/Output Signal Reference Values"](#) .

OK or NG

OK >> GO TO 9.

NG >> Check transfer control unit pin terminals for damage or loose connection with harness connector.
If any items are damaged, repair or replace damaged parts.

9. CHECK TRANSFER INNER PARTS

1. Disassemble transfer assembly. Refer to [TF-112, "Disassembly and Assembly"](#) .

2. Check transfer inner parts.

OK or NG

OK >> Inspection End.

NG >> Repair or replace damaged parts.

ATP Warning Lamp Does Not Turn ON

SYMPTOM:

EDS002YC

ATP warning lamp does not turn ON when 4WD shift switch is switched from "4H" to "4LO" or "4LO" to "4H" with A/T selector lever in "N" position.

DIAGNOSTIC PROCEDURE

1. CHECK SYSTEM FOR CAN COMMUNICATION LINE

Perform self-diagnosis. Refer to [TF-47, "Self-Diagnostic Procedure"](#) .

Do the self-diagnostic results indicate CAN communication?

YES >> Perform trouble diagnosis for CAN communication line. Refer to [TF-84, "CAN Communication Line"](#) .

NO >> GO TO 2.

2. CHECK SYSTEM FOR 4WD SHIFT SWITCH

Perform trouble diagnosis for 4WD shift switch system. Refer to [TF-59, "4WD Shift Switch"](#) .

OK or NG

OK >> GO TO 3.

NG >> Repair or replace damaged parts.

3. CHECK SYSTEM FOR PNP SWITCH SIGNAL

Perform trouble diagnosis for PNP switch signal system. Refer to [TF-67, "PNP Switch Signal \(A/T models\)"](#) .

OK or NG

OK >> GO TO 4.

NG >> Repair or replace damaged parts.

4. CHECK SYSTEM FOR ATP SWITCH

Perform trouble diagnosis for ATP switch system. Refer to [TF-84, "ATP Switch"](#) .

OK or NG

OK >> GO TO 5.

NG >> Repair or replace damaged parts.

TROUBLE DIAGNOSIS FOR SYMPTOMS

5. CHECK ATP WARNING LAMP CIRCUIT

1. Disconnect ATP switch harness connector.
2. Turn ignition switch "ON". (Do not start engine.)
3. Ground the following terminal using suitable wiring.
 - ATP switch harness connector F55 terminal 8 and ground.
4. Turn ignition switch "OFF". (Stay for at least 5 seconds.)

Does ATP warning lamp turn on?

- OK >> GO TO 9.
NG >> GO TO 6.

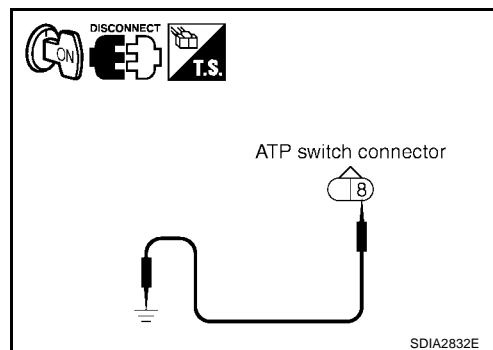

6. CHECK HARNESS BETWEEN TRANSFER CONTROL UNIT AND COMBINATION METER

1. Turn ignition switch "OFF". (Stay for at least 5 seconds.)
2. Disconnect transfer control unit harness connector and combination meter harness connector.
3. Check continuity between transfer control unit harness connector M153 terminal 39 and combination meter harness connector M24 terminal 21.

Continuity should exist.

Also check harness for short to ground and short to power.

OK or NG

- OK >> GO TO 7.
NG >> Repair or replace damaged parts.

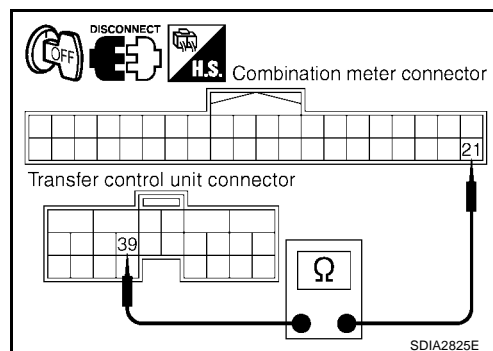

7. CHECK HARNESS BETWEEN COMBINATION METER AND ATP SWITCH

1. Turn ignition switch "OFF". (Stay for at least 5 seconds.)
2. Disconnect ATP switch harness connector.
3. Check continuity between combination meter harness connector M24 terminal 1 and ATP switch harness connector F55 terminal 8.

Continuity should exist.

Also check harness for short to ground and short to power.

OK or NG

- OK >> GO TO 8.
NG >> Repair or replace damaged parts.

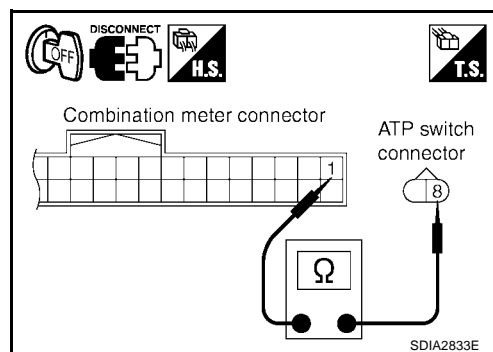

8. SYMPTOM CHECK

Check again.

OK or NG

- OK >> Inspection End.
NG >> GO TO 9.

TROUBLE DIAGNOSIS FOR SYMPTOMS

9. CHECK TRANSFER CONTROL UNIT

Check transfer control unit input/output signal. Refer to [TF-37, "Transfer Control Unit Input/Output Signal Reference Values"](#) .

OK or NG

OK >> GO TO 10.

NG >> Check transfer control unit pin terminals for damage or loose connection with harness connector.
If any items are damaged, repair or replace damaged parts.

10. CHECK TRANSFER INNER PARTS

1. Disassemble transfer assembly. Refer to [TF-112, "Disassembly and Assembly"](#) .

2. Check transfer inner parts.

OK or NG

OK >> Inspection End.

NG >> Repair or replace damaged parts.

4WD Shift Indicator Lamp Repeats Flashing SYMPTOM:

EDS002YD

4WD shift indicator lamp keeps flashing.

DIAGNOSTIC PROCEDURE

1. CONFIRM THE SYMPTOM

1. Set 4WD shift switch to "2WD".

2. Move vehicle forward and backward, or drive straight increasing or decreasing under 20 km/h (12 MPH).

Does 4WD shift indicator lamp keep flashing?

YES >> GO TO 2.

NO >> Inspection End.

2. CHECK SYSTEM FOR WAIT DETECTION SWITCH

Perform trouble diagnosis for wait detection switch system. Refer to [TF-63, "Wait Detection Switch"](#) .

OK or NG

OK >> GO TO 3.

NG >> Repair or replace damaged parts.

3. CHECK SYSTEM FOR 4LO SWITCH

Perform trouble diagnosis for 4LO switch system. Refer to [TF-56, "4LO Switch"](#) .

OK or NG

OK >> GO TO 4.

NG >> Repair or replace damaged parts.

4. SYMPTOM CHECK

Check again.

OK or NG

OK >> Inspection End.

NG >> GO TO 5.

TROUBLE DIAGNOSIS FOR SYMPTOMS

5. CHECK TRANSFER CONTROL UNIT

Check transfer control unit input/output signal. Refer to [TF-37, "Transfer Control Unit Input/Output Signal Reference Values"](#) .

OK or NG

OK >> GO TO 6.

NG >> Check transfer control unit pin terminals for damage or loose connection with harness connector. If any items are damaged, repair or replace damaged parts.

6. CHECK TRANSFER INNER PARTS

1. Disassemble transfer assembly. Refer to [TF-112, "Disassembly and Assembly"](#) .

2. Check transfer inner parts.

OK or NG

OK >> Inspection End.

NG >> Repair or replace damaged parts.

4WD Warning Lamp Flashes Slowly

EDS002YE

SYMPTOM:

While driving, 4WD warning lamp flashes slowly. (Continues to flash until turning ignition switch OFF.)

NOTE:

Slow flashing: 1 time/2 seconds

DIAGNOSTIC PROCEDURE

1. CHECK TIRES

Check the following.

- Tire pressure
- Wear condition
- Confirm there is no difference between tire size

OK or NG

OK >> GO TO 2.

NG >> Repair or replace damaged parts.

2. SYMPTOM CHECK

Check again.

OK or NG

OK >> Inspection End.

NG >> GO TO 3.

3. CHECK TRANSFER CONTROL UNIT

Check transfer control unit input/output signal. Refer to [TF-37, "Transfer Control Unit Input/Output Signal Reference Values"](#) .

OK or NG

OK >> Inspection End.

NG >> Check transfer control unit pin terminals for damage or loose connection with harness connector. If any items are damaged, repair or replace damaged parts.

TRANSFER CONTROL UNIT

TRANSFER CONTROL UNIT

PFP:33084

Removal and Installation

EDS002NB

REMOVAL

1. Switch 4WD shift switch to 2WD and set transfer assembly to 2WD.

CAUTION:

When removing transfer control unit, transfer state must be at 2WD.

2. Turn the ignition switch OFF and disconnect negative battery terminal.
3. Remove the lower instrument panel LH. Refer to [IP-12, "LOWER INSTRUMENT PANEL LH"](#).
4. Disconnect the two transfer control unit connectors.
5. Remove the transfer control unit bolts.
6. Remove the transfer control unit.

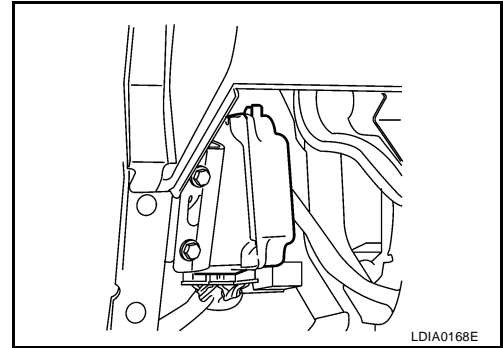

INSTALLATION

Installation is in the reverse order of removal.

- When installing the transfer control unit, tighten bolts to the specified torque.

Transfer control unit bolts : 3.4 N·m (0.35 kg-m, 30 in-lb)

- After the installation, check 4WD shift indicator pattern. If NG, adjust position between transfer assembly and transfer control unit. Refer to [TF-4, "Precautions for Transfer Assembly and Transfer Control Unit Replacement"](#).

FRONT OIL SEAL

PFP:38189

EDS002NC

FRONT OIL SEAL

Removal and Installation

REMOVAL

1. Partially drain the transfer fluid. Refer to [TF-12, "DRAINING"](#) .
2. Remove the front propeller shaft. Refer to [PR-5, "Removal and Installation"](#) .
3. Remove the companion flange self-lock nut, using Tool.

Tool number : KV40104000 (—)

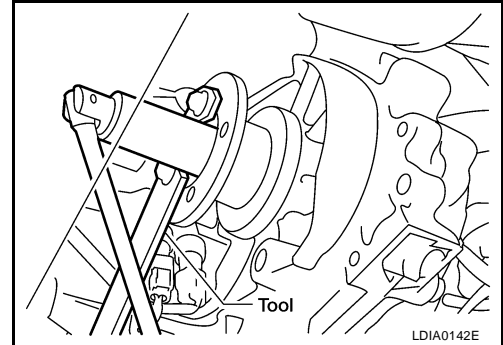

4. Put a matching mark on top of the front drive shaft in line with the mark on the companion flange.

CAUTION:

Use paint to make the matching mark on the front drive shaft. Do not damage the front drive shaft.

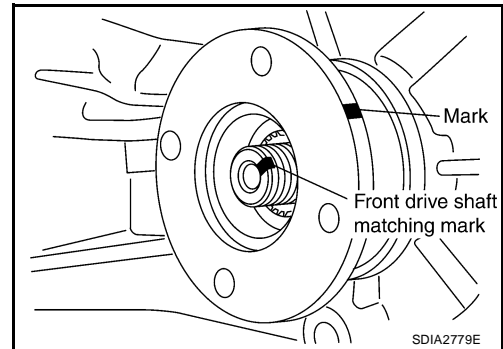

5. Remove the companion flange, using suitable tool.

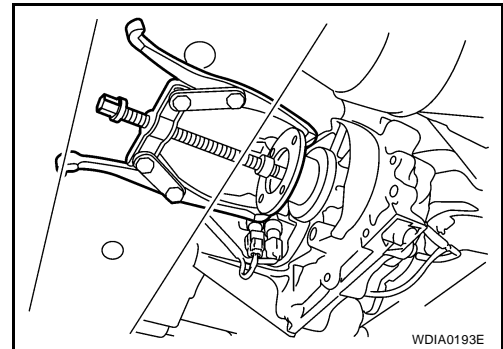

6. Remove the front oil seal from the front case, using Tool.

Tool number : KV381054S0 (J-34286)

CAUTION:

Do not damage front case.

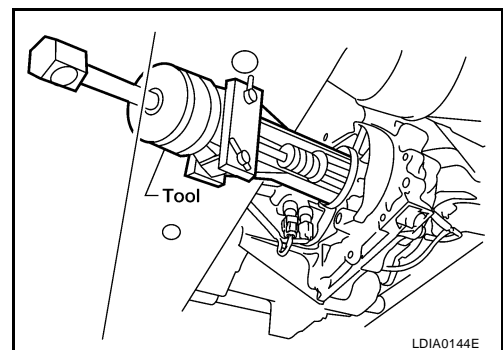

A
B
C
TF
E
F
G
H
I
J
K
L
M

FRONT OIL SEAL

INSTALLATION

1. Install the new front oil seal until it is flush with the end face of the front case, using Tool.

Tool number : KV38100500 (—)

CAUTION:

- Do not reuse oil seal.
- Apply petroleum jelly to oil seal.

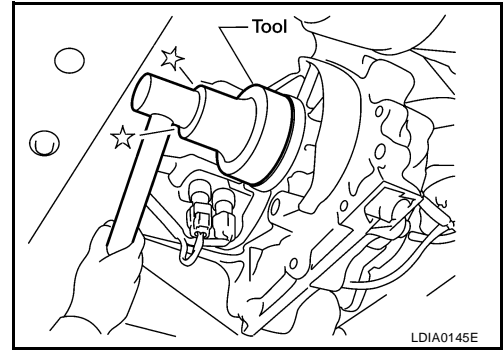

2. Align the matching mark of the front drive shaft with the matching mark of the companion flange, then install the companion flange.

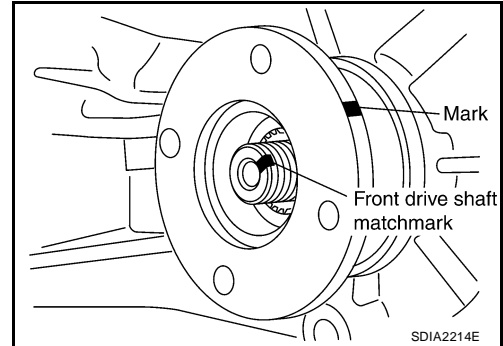

3. Install the new self-lock nut and tighten to the specified torque, using Tool. Refer to [TF-112, "COMPONENTS"](#).

Tool number : KV40104000 (—)

CAUTION:

Do not reuse self-lock nut.

4. Install the front propeller shaft. Refer to [PR-5, "Removal and Installation"](#).
5. Refill the transfer with fluid and check fluid level. Refer to [TF-12, "FILLING"](#).
6. Check the transfer for fluid leakage. Refer to [TF-12, "FLUID LEAKAGE AND FLUID LEVEL"](#).

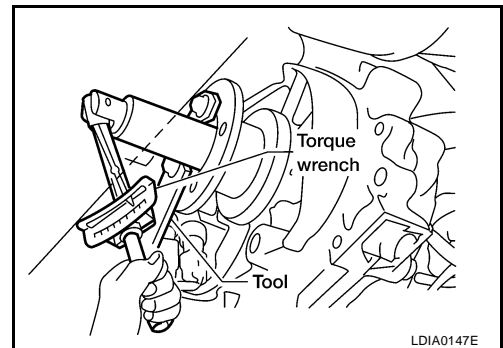

REAR OIL SEAL

PFP:33140

EDS002ND

REAR OIL SEAL

Removal and Installation

REMOVAL

1. Partially drain the transfer fluid. Refer to [TF-12, "DRAINING"](#).
2. Remove the rear propeller shaft. Refer to [PR-10, "Removal and Installation"](#).
3. Remove the dust cover from the rear case.

CAUTION:

Do not damage the rear case.

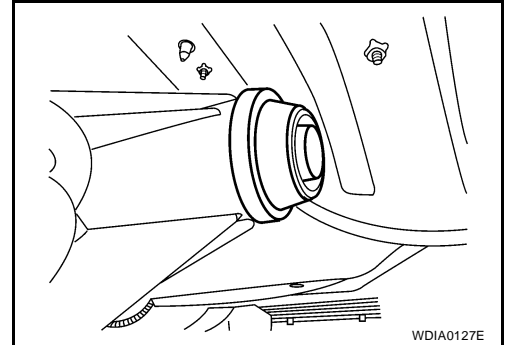

4. Remove the rear oil seal from the rear case, using Tool.

CAUTION:

Do not damage the rear case.

Tool number : KV381054S0 (J-34286)

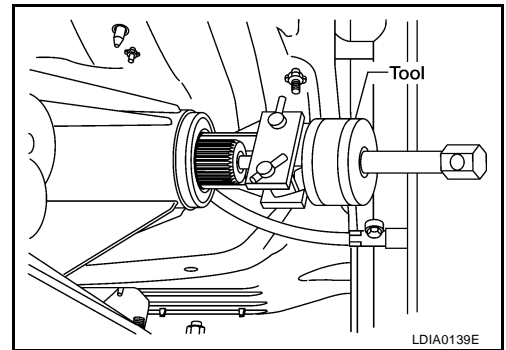

INSTALLATION

1. Install the new rear oil seal until it is flush with the end face of the rear case, using Tool.

Tool number : KV38100500 (—)

CAUTION:

- Do not reuse oil seal.
- Apply petroleum jelly to oil seal.

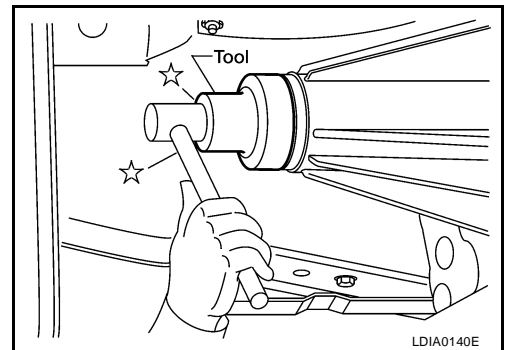

2. Apply petroleum jelly to the circumference of the new dust cover. Position the dust cover using the identification mark as shown.

CAUTION:

- Do not reuse dust cover.
- Position the identification mark at the position shown.

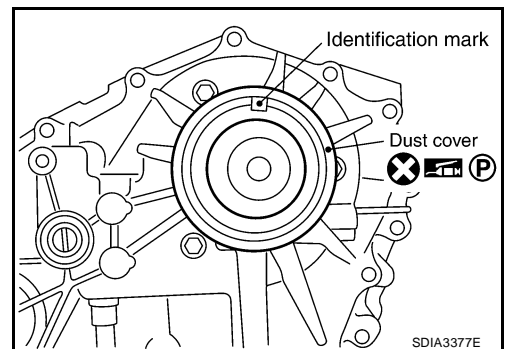

A
B
C
TF
E
F
G
H
I
J
K
L
M

REAR OIL SEAL

3. Install the new dust cover to the rear case, using Tool.

Tool number : KV40105310 (—)

CAUTION:

- Do not reuse dust cover.
 - Apply petroleum jelly to dust cover.
4. Install the rear propeller shaft. Refer to [PR-10, "Removal and Installation"](#) .
 5. Refill the transfer with fluid and check fluid level. Refer to [TF-12, "FILLING"](#) .
 6. Check the transfer for fluid leakage. Refer to [TF-12, "FLUID LEAKAGE AND FLUID LEVEL"](#) .

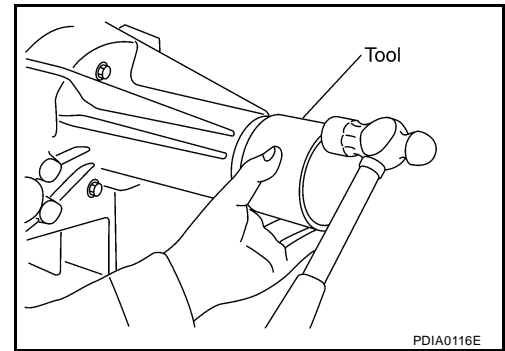

TRANSFER CONTROL DEVICE

PFP:33251

EDS002NE

TRANSFER CONTROL DEVICE

Removal and Installation

REMOVAL

1. Switch the 4WD shift switch to 2WD and set the transfer assembly to 2WD.
2. Disconnect the transfer control device connector.
3. Remove the breather hose from the transfer control device.
4. Remove the bolts and detach the transfer control device.

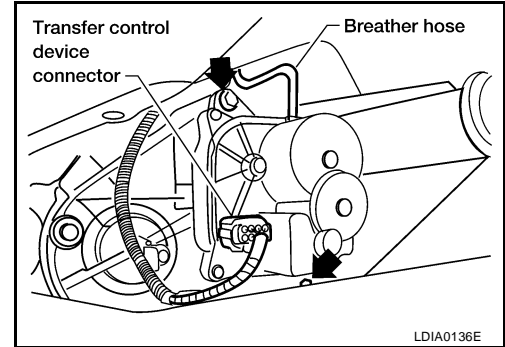

INSTALLATION

1. Install the new O-ring to the transfer control device.

CAUTION:

- Do not reuse O-ring.
- Apply petroleum jelly to O-ring.

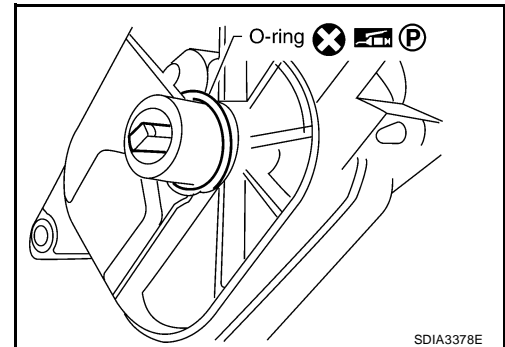

2. Install the transfer control device.
 - a. Turn the control shift rod fully counterclockwise using suitable tool, and then put a mark on the control shift rod.

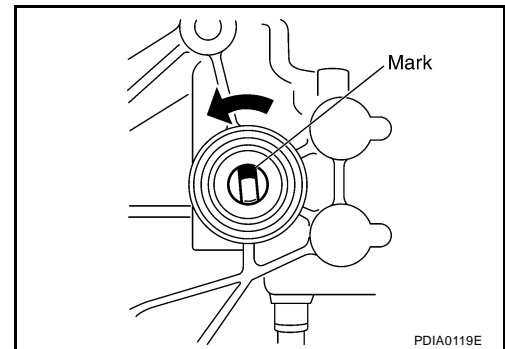

- b. Align the transfer control device shaft cutout with the mark on the control shift rod, and install.

NOTE:

Turn the transfer control device when the transfer control device connection does not match.

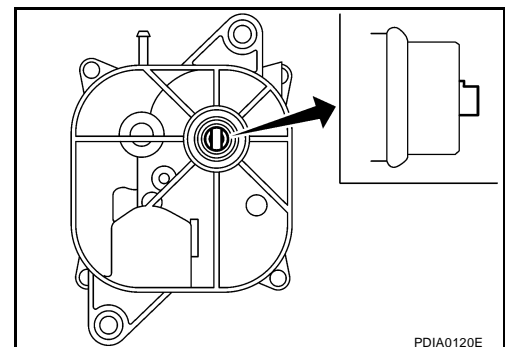

TRANSFER CONTROL DEVICE

- c. Tighten the bolts to the specified torque. Refer to [TF-112, "COMPONENTS"](#).
3. Install the breather hose to the transfer control device.
4. Connect the transfer control device connector.
5. After the installation, check the 4WD shift indicator pattern. If NG, adjust the position between the transfer assembly and transfer control unit. Refer to [TF-4, "Precautions for Transfer Assembly and Transfer Control Unit Replacement"](#).

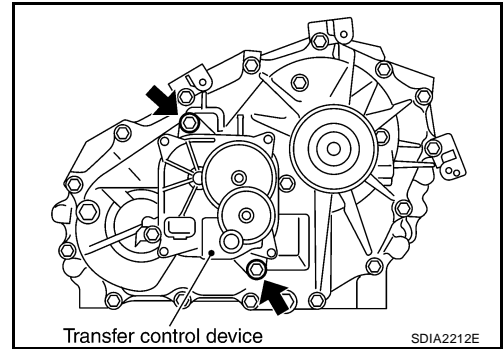

AIR BREATHER HOSE

AIR BREATHER HOSE

PFP:31098

Removal and Installation

EDS002NF

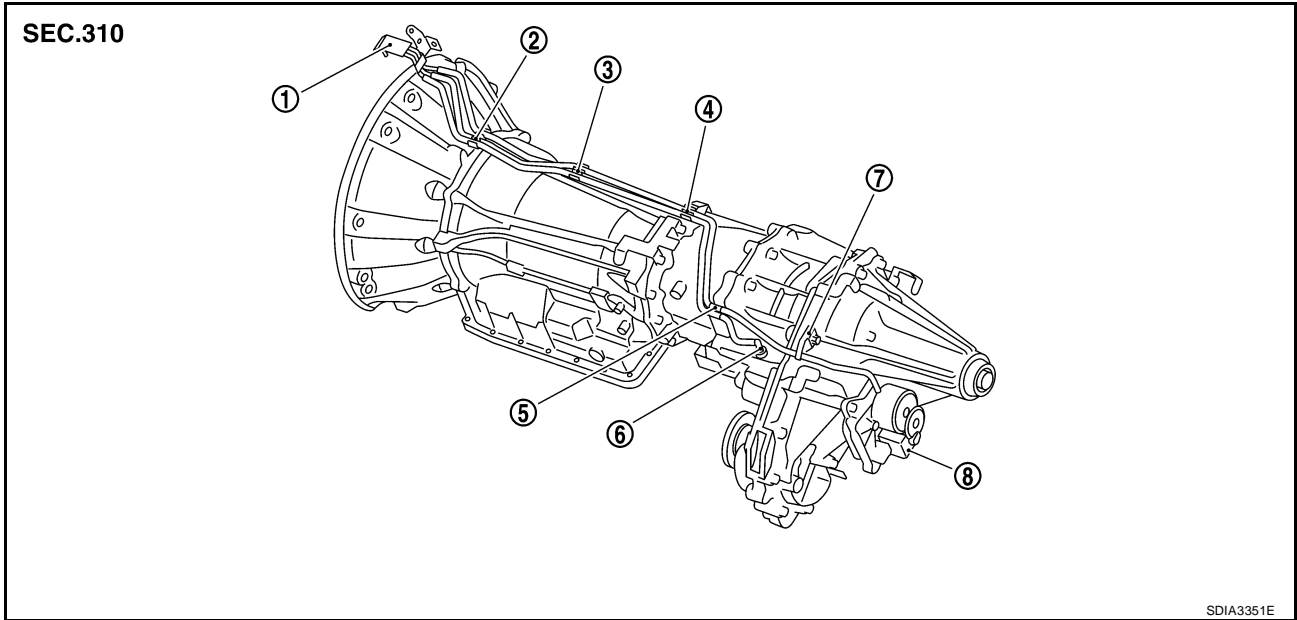

- | | | |
|----------------------------|----------------------------|-----------------------------|
| 1. Breather tube | 2. Clip A | 3. Clip B |
| 4. Clip C | 5. Clip D | 6. Breather tube (transfer) |
| 7. Air breather hose clamp | 8. Transfer control device | |

CAUTION:

- Make sure there are no pinched or restricted areas on each air breather hose caused by bending or winding when installing it.
- Install each air breather hose into the breather tube (metal connector) until the hose end reaches the end of the curved section. Set each air breather hose with paint mark facing upward.

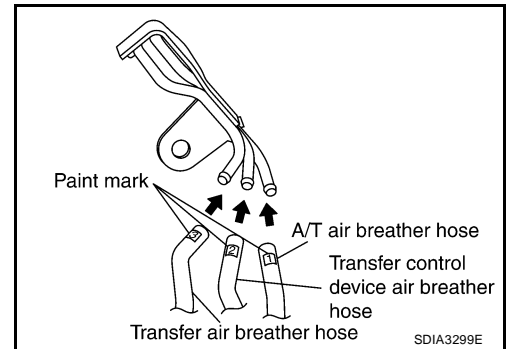

- Install transfer control device air breather hose and transfer air breather hose on clip A and clip B with the paint mark facing upward.

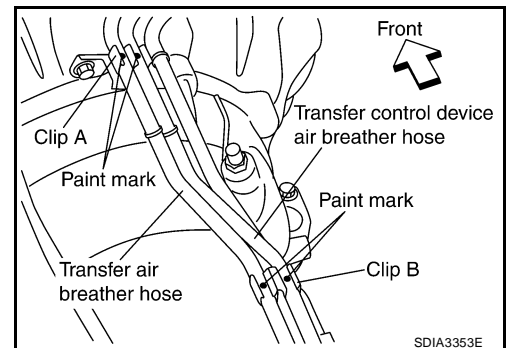

AIR BREATHER HOSE

- Install clip C on transfer control device air breather hose and transfer air breather hose with the paint mark matched.

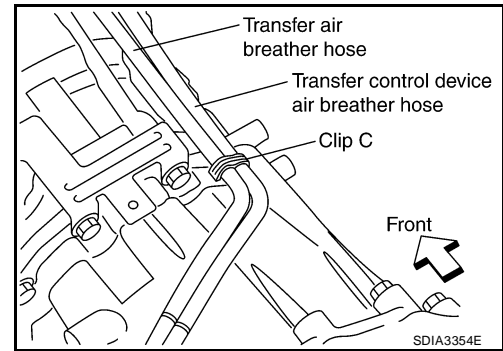

- Install transfer control device air breather hose and transfer air breather hose on clip D with the paint mark facing upward.

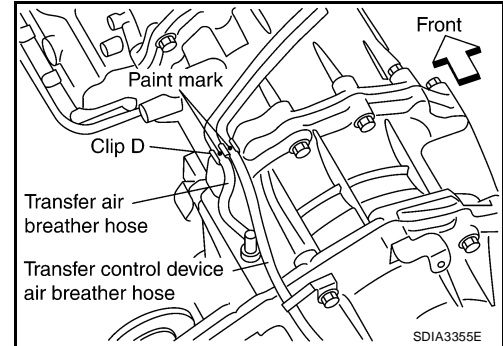

- Install transfer air breather hose into the breather tube (transfer, metal connector) until the hose end reaches the base of the tube. Set transfer air breather hose with paint mark facing upward.

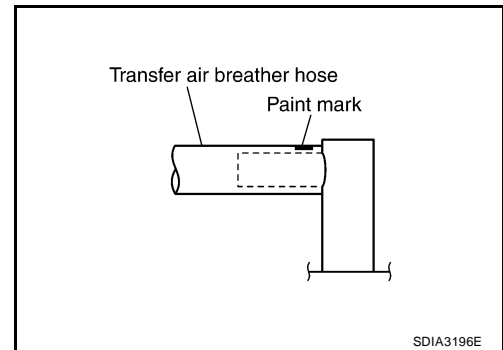

- Install transfer control device air breather hose into transfer control device (case connector) until the hose end reaches the base of the tube. Set transfer control device air breather hose with paint mark facing forward.

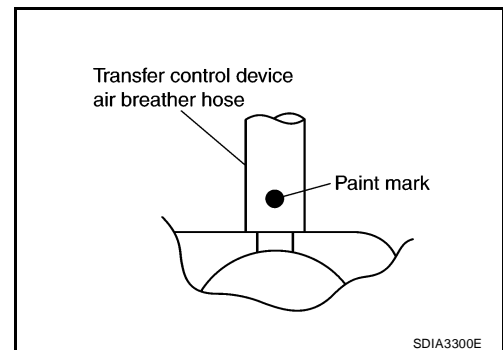

TRANSFER ASSEMBLY

PF3:33100

TRANSFER ASSEMBLY

Removal and Installation

EDS002NG

REMOVAL

1. Switch 4WD shift switch to 2WD and set transfer assembly to 2WD.
2. Drain the transfer fluid. Refer to [TF-12, "TRANSFER FLUID"](#).
3. Remove undercovers using power tool.
4. Remove the center exhaust tube and main muffler. Refer to [EX-4, "Removal and Installation"](#).
5. Remove the front and rear propeller shafts. Refer to [PR-5, "Removal and Installation"](#) (front), [PR-10, "Removal and Installation"](#) (rear).

CAUTION:

Do not damage spline, sleeve yoke and rear oil seal when removing rear propeller shaft.

NOTE:

Insert a plug into the rear oil seal after removing the rear propeller shaft.

6. Remove the transmission bolts. Refer to [MT-19, "COMPONENTS"](#) (for M/T) or [AT-251, "COMPONENTS"](#) (for A/T).
7. Position two suitable jacks under the transmission and transfer assembly.
8. Remove the transmission crossmember. Refer to [MT-19, "COMPONENTS"](#) (for M/T) or [AT-251, "COMPONENTS"](#) (for A/T).

WARNING:

Support transmission and transfer assembly using two suitable jacks while removing transmission crossmember.

9. Disconnect the electrical connectors from the following:
 - ATP switch
 - 4LO switch
 - Wait detection switch
 - Transfer control device
10. Disconnect each air breather hose from the following. Refer to [TF-109, "Removal and Installation"](#).
 - Transfer control device
 - Breather tube (transfer)

11. Remove the transfer to transmission and transmission to transfer bolts.

WARNING:

Support transfer assembly with suitable jack while removing it.

12. Remove the transfer assembly.

CAUTION:

Do not damage transmission rear oil seal.

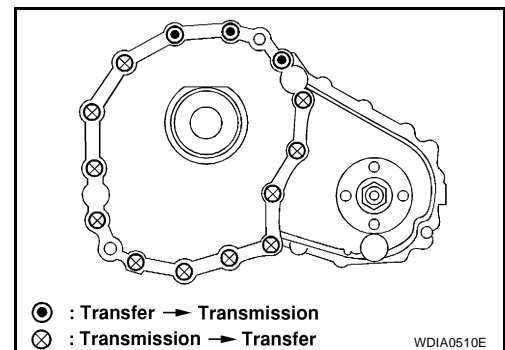

INSTALLATION

Installation is in the reverse order of removal.

- Tighten the bolts to specification.

Tightening torque : 36 N·m (3.7kg·m, 27 ft·lb)

- Fill the transfer with new fluid. Refer to [TF-12, "FILLING"](#).
- Check the transfer fluid. Refer to [TF-12, "FLUID LEAKAGE AND FLUID LEVEL"](#).
- Start the engine for one minute. Then stop the engine and recheck the transfer fluid. Refer to [TF-12, "FLUID LEAKAGE AND FLUID LEVEL"](#).
- After the installation, check the 4WD shift indicator pattern. If NG, adjust the position between the transfer assembly and

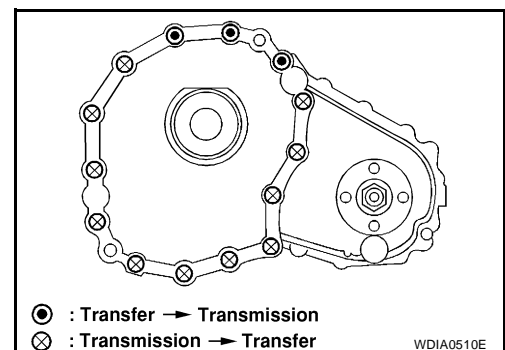

TRANSFER ASSEMBLY

transfer control unit. Refer to [TF-4, "Precautions for Transfer Assembly and Transfer Control Unit Replacement"](#).

Disassembly and Assembly COMPONENTS

EDS002NH

SEC.330·331·332·333

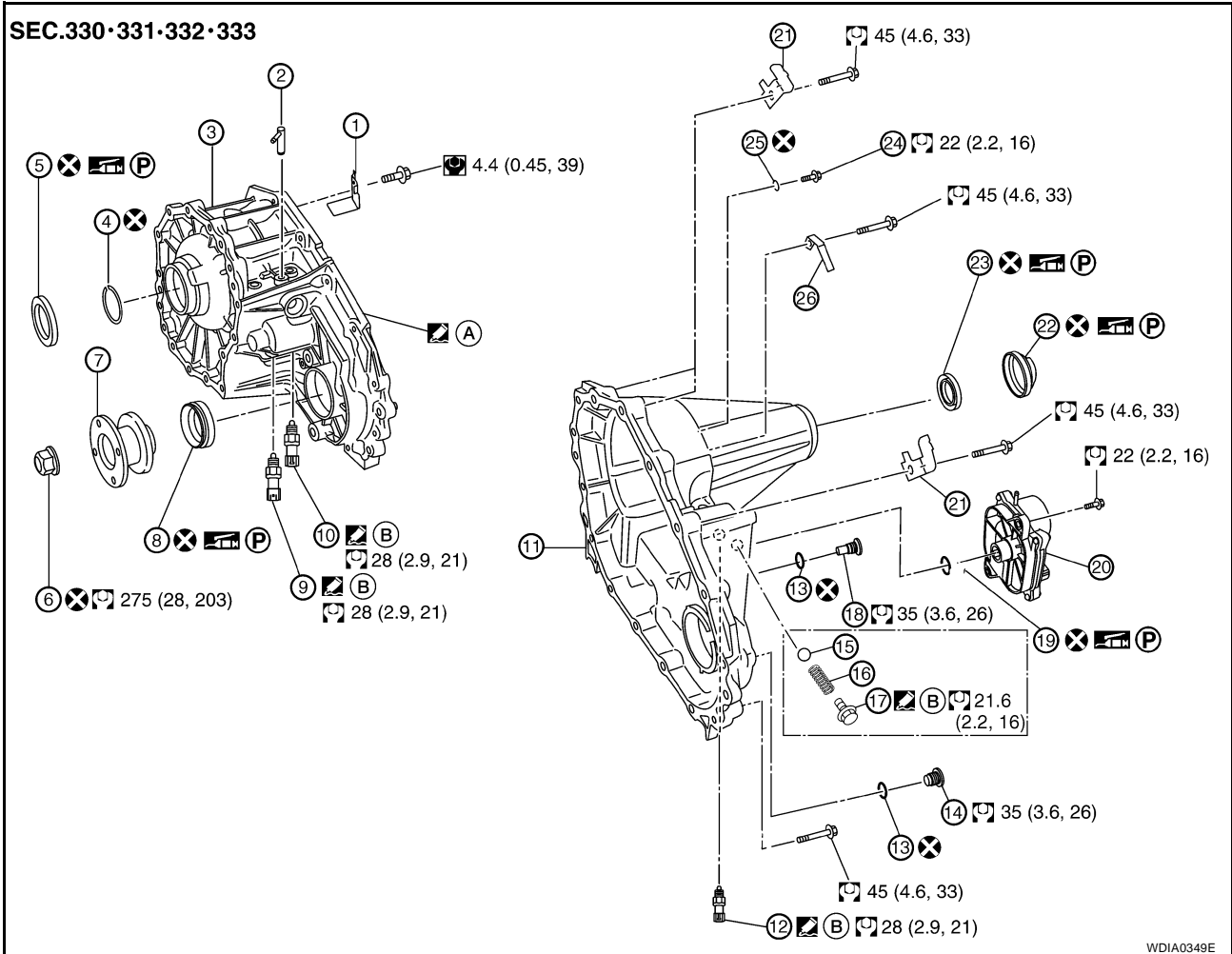

WDIA0349E

- | | | |
|--|----------------------------------|---------------------------------------|
| 1. Baffle plate | 2. Breather tube | 3. Front case |
| 4. Snap ring | 5. Input oil seal | 6. Self-lock nut |
| 7. Companion flange | 8. Front oil seal | 9. 4LO switch (gray with green paint) |
| 10. ATP switch (black) | 11. Rear case | 12. Wait detection switch (gray) |
| 13. Gasket | 14. Filler plug | 15. Check ball (M/T models only) |
| 16. Check shift spring (M/T models only) | 17. Check plug (M/T models only) | 18. Drain plug |
| 19. O-ring | 20. Transfer control device | 21. Harness bracket |
| 22. Dust cover | 23. Rear oil seal | 24. Retainer bolt |
| 25. Gasket | 26. Air breather hose clamp | |
- A. Apply Genuine Anaerobic Liquid Gasket or equivalent.
- B. Apply Genuine Silicone RTV or equivalent.

TRANSFER ASSEMBLY

SEC.332•333

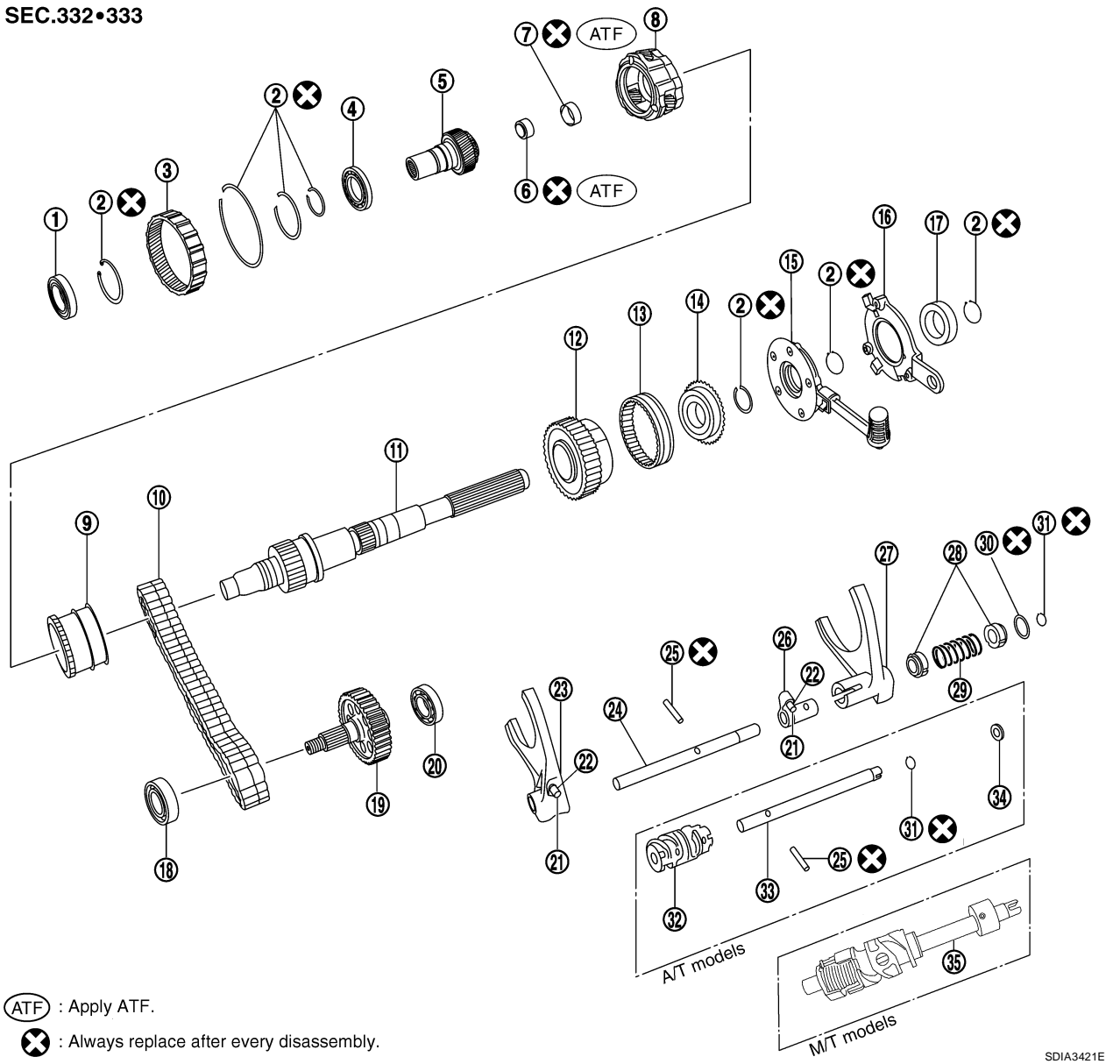

- | | | |
|-----------------------|--------------------------------|-----------------------|
| 1. Input bearing | 2. Snap ring | 3. Internal gear |
| 4. Carrier bearing | 5. Sun gear | 6. Needle bearing |
| 7. Metal bushing | 8. Planetary carrier assembly | 9. L-H sleeve |
| 10. Drive chain | 11. Mainshaft | 12. Sprocket |
| 13. 2-4 sleeve | 14. Clutch gear | 15. Oil pump assembly |
| 16. Retainer | 17. Mainshaft rear bearing | 18. Front bearing |
| 19. Front drive shaft | 20. Rear bearing | 21. Clevis pin |
| 22. Shift collar | 23. L-H shift fork | 24. L-H shift rod |
| 25. Retaining pin | 26. 2-4 shift bracket | 27. 2-4 shift fork |
| 28. Fork guide collar | 29. 2-4 shift fork spring | 30. Retaining ring |
| 31. Snap ring | 32. Drum cam | 33. Control shift rod |
| 34. Spacer | 35. Control shift rod assembly | |

SDIA3421E

A
 B
 C
TF
 E
 F
 G
 H
 I
 J
 K
 L
 M

TRANSFER ASSEMBLY

DISASSEMBLY

1. Remove the drain plug and filler plug.
2. Remove the transfer control device from the rear case.
3. Remove the O-ring from the transfer control device.

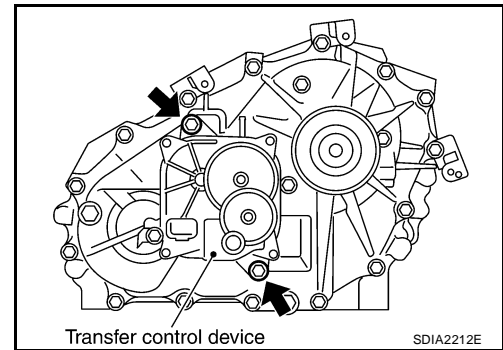

4. Remove the self-lock nut from the companion flange, using Tool.
Tool number : KV40104000 (—)

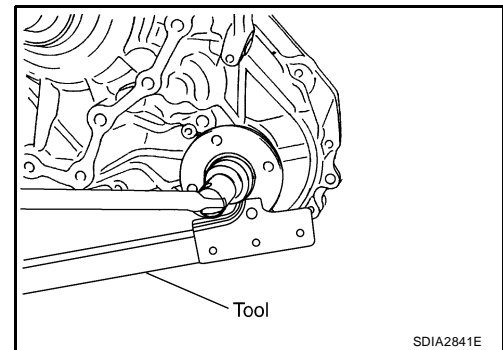

5. Put a matching mark on top of the front drive shaft in line with the mark on the companion flange.

CAUTION:

Use paint to make the matching mark on the front drive shaft. Do not damage the front drive shaft.

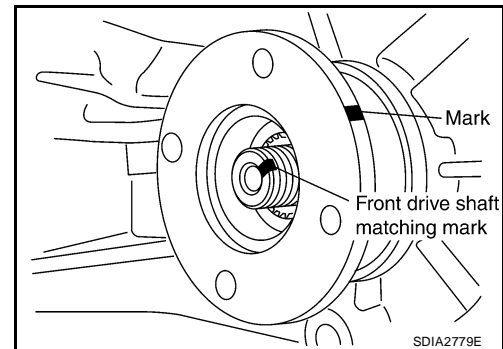

6. Remove the companion flange, using suitable tool.

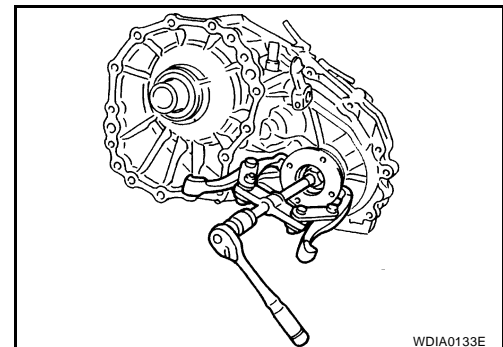

TRANSFER ASSEMBLY

7. Remove the front oil seal from the front case, using Tool.

Tool number : KV381054S0 (J-34286)

CAUTION:

Do not damage front case or front drive shaft.

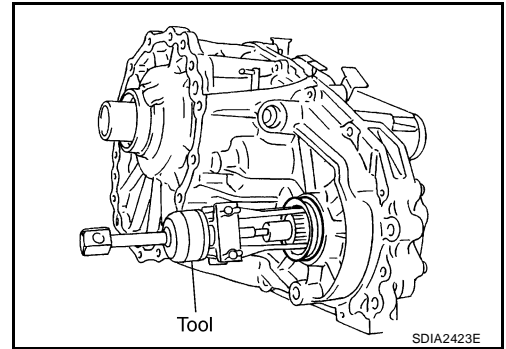

8. Remove the 4LO switch [gray (with green paint)] and ATP switch (black) from the front case.

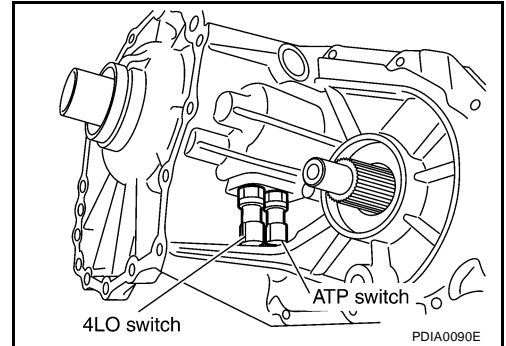

9. Remove the wait detection switch (gray) from the rear case.

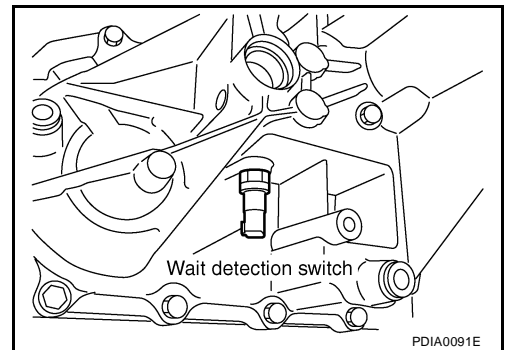

10. Remove check plug, check shift spring and check ball (M/T models only).

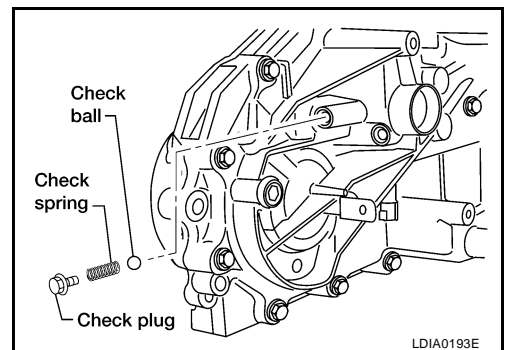

11. Remove the dust cover from the rear case, using suitable tool.

CAUTION:

Do not damage rear case.

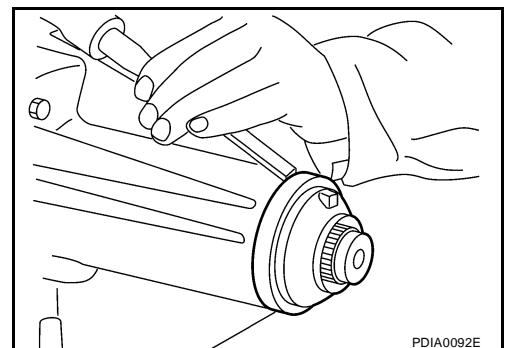

A
B
C
TF
E
F
G
H
I
J
K
L
M

TRANSFER ASSEMBLY

12. Remove the rear oil seal from the rear case, using Tool.

Tool number : KV381054S0 (J-34286)

CAUTION:

Do not damage rear case or mainshaft.

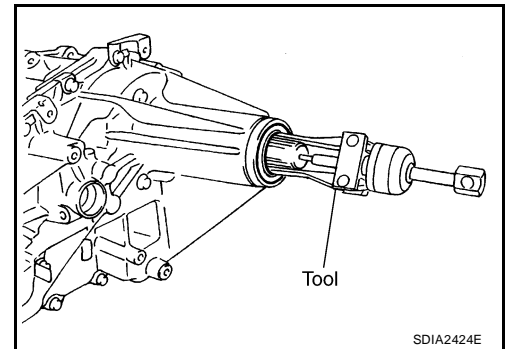

13. Remove the input oil seal from the front case, using suitable tool.

CAUTION:

Do not damage front case, sun gear or input bearing.

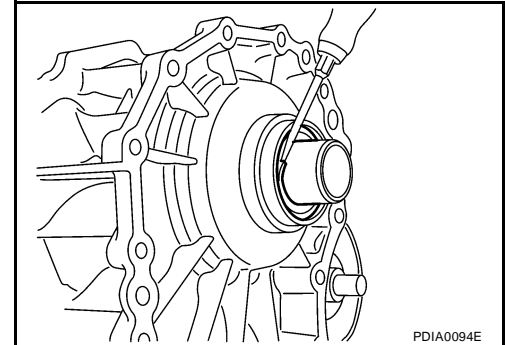

14. Remove the retainer bolts and gaskets.

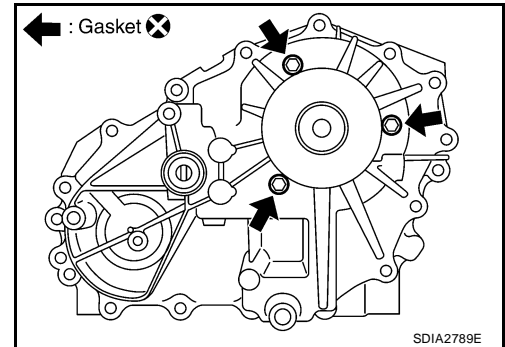

15. Remove the rear case bolts, harness bracket and air breather hose clamp from the rear case.

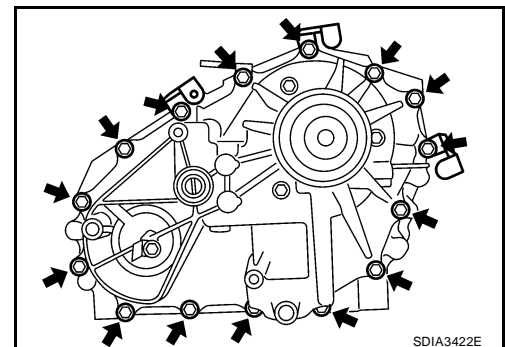

16. Separate the front case from the rear case. Then remove the rear case by prying it up, using suitable tool.

CAUTION:

Do not damage the mating surface.

17. Remove the spacer from the control shift rod (A/T models only).

CAUTION:

Do not drop spacer.

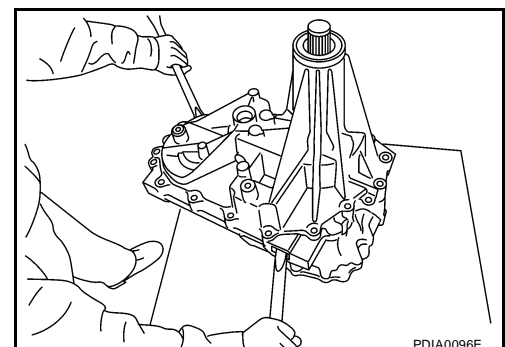

TRANSFER ASSEMBLY

18. Remove the snap ring from the mainshaft, using suitable tool.

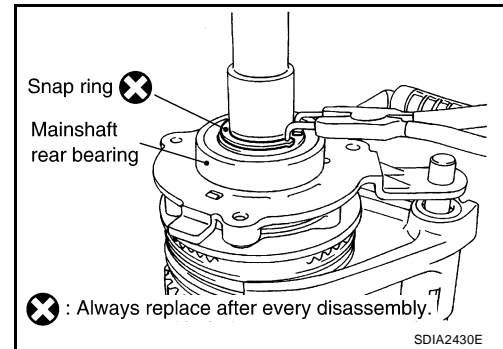

19. Remove the mainshaft rear bearing from the mainshaft, using suitable tool.

20. Remove the retainer from the mainshaft.

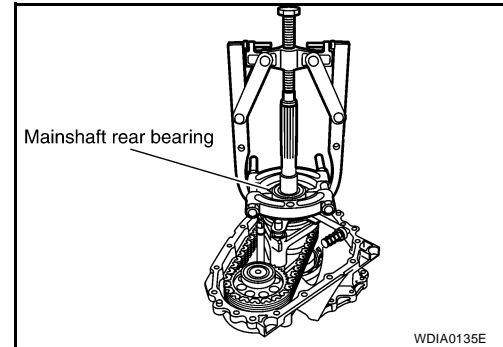

21. Remove the snap ring from the mainshaft, using suitable tool.

22. Remove the oil pump assembly from the mainshaft.

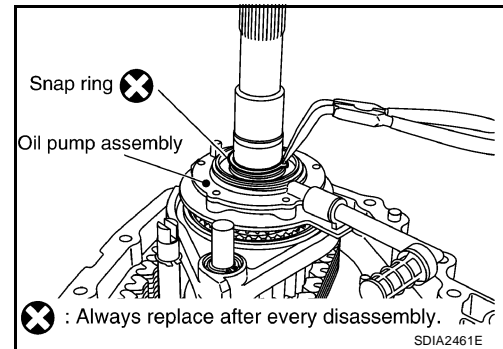

23. Remove the snap ring from the mainshaft, using suitable tool.

24. Remove the clutch gear from the mainshaft.

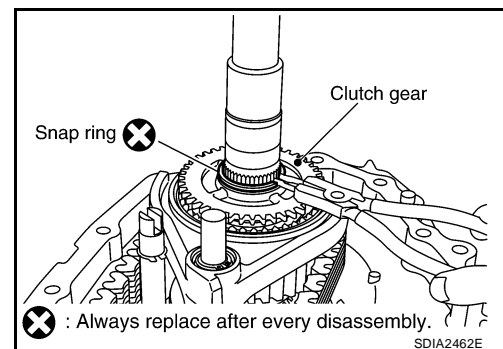

25. Remove the snap ring from the L-H shift rod assembly, using suitable tool.

26. Remove the 2-4 sleeve and 2-4 shift fork assembly from the mainshaft.

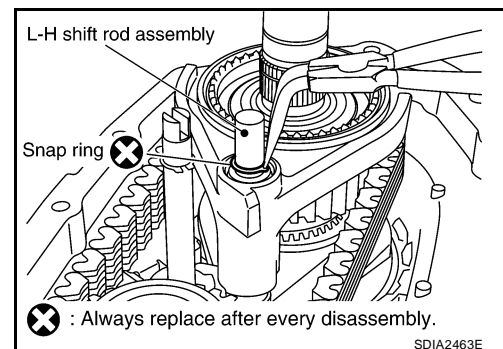

A
B
C
TF
E
F
G
H
I
J
K
L
M

TRANSFER ASSEMBLY

27. Remove the drive chain together with the sprocket and front drive shaft from the front case.
28. Remove the mainshaft from the sun gear assembly.
29. Remove the L-H shift rod assembly and control shift rod assembly from the front case.
30. Remove the L-H sleeve together with the L-H shift fork from the planetary carrier assembly.

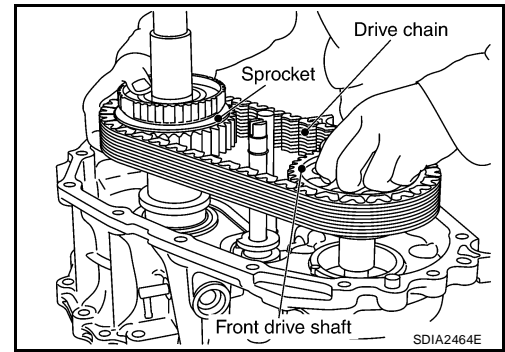

31. Remove the snap ring from the sun gear.
CAUTION:
Do not damage sun gear or input bearing.

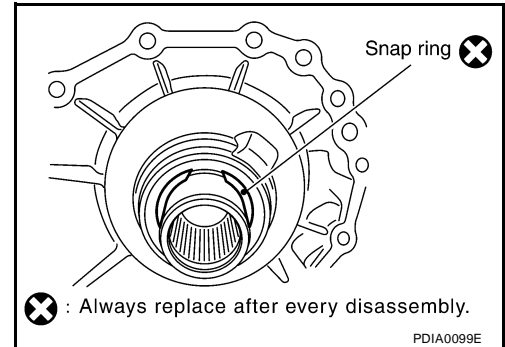

32. Press the sun gear assembly and planetary carrier assembly from the front case, using Tool.

Tool number : KV38100200 (—)

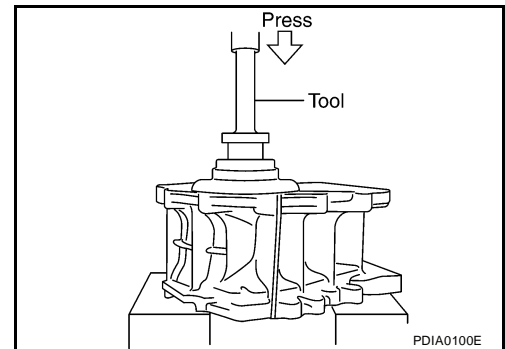

33. Remove the snap ring from the front case.

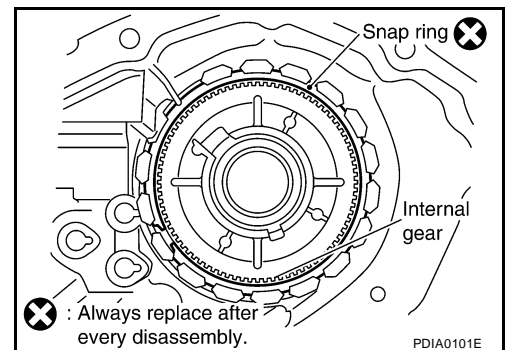

34. Remove the internal gear from the front case.

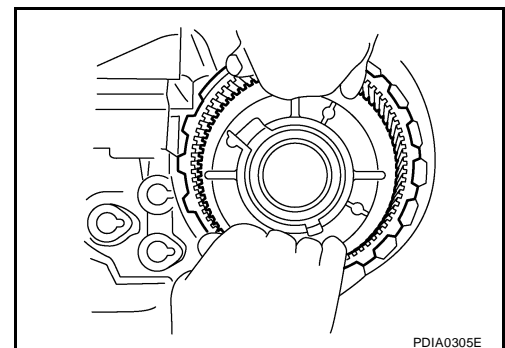

TRANSFER ASSEMBLY

35. Remove the snap ring from the front case.

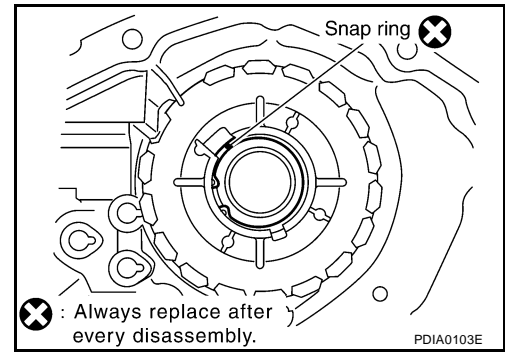

36. Remove the input bearing from the front case, using Tool.

Tool number : KV38100200 (—)

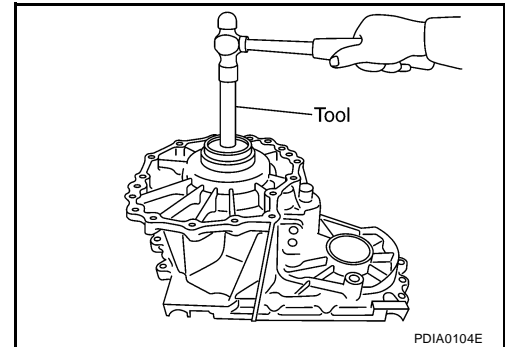

37. Remove the baffle plate from the front case.

38. Remove the breather tube from the front case.

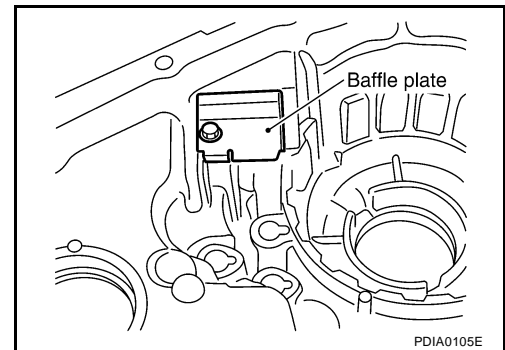

INSPECTION AFTER DISASSEMBLY

Case

Check the contact surfaces of the shift rod and bearing for wear and damage. If any is found, replace with a new one.

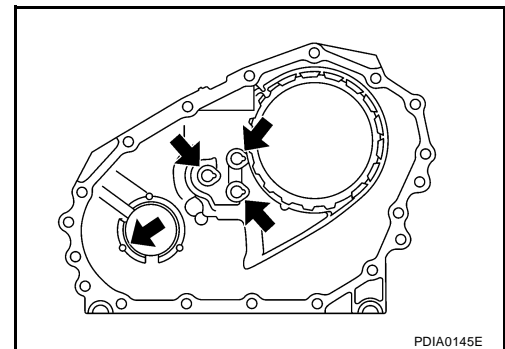

A
B
C
TF
E
F
G
H
I
J
K
L
M

TRANSFER ASSEMBLY

Sleeve

Check the items below. If necessary, replace them with new ones.

- Damage and excessive wear of the contact surfaces of the sprocket, mainshaft and sleeve.
- Sleeve must move smoothly.

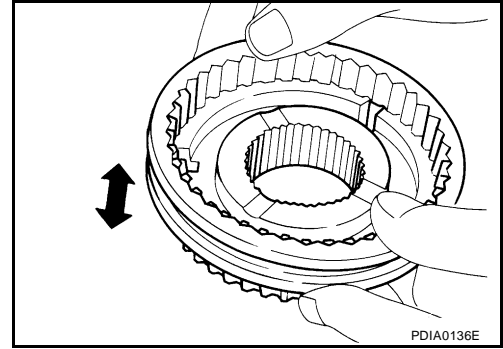

Gear, Shaft and Drive Chain

Check the items below. If necessary, replace them with new ones.

- Damage, peeling, uneven wear and bending of the shaft.
- Excessive wear, damage and peeling of the gear.

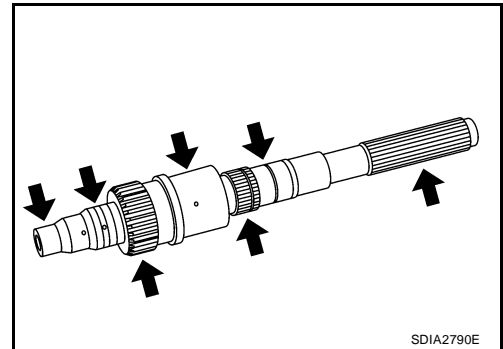

Bearing

Check the bearing for damage and rough rotation. If necessary, replace it with a new one.

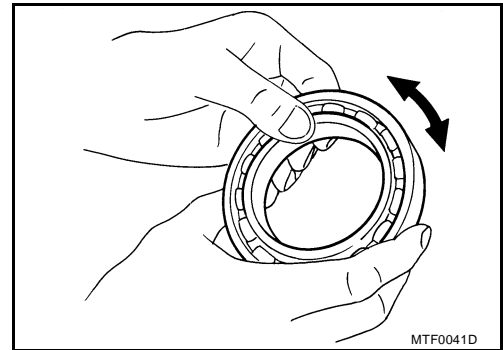

ASSEMBLY

1. Install the breather tube.

CAUTION:

Install breather tube in the direction shown.

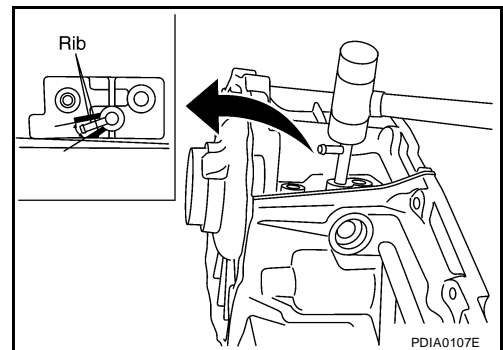

TRANSFER ASSEMBLY

2. Install the baffle plate to the front case. Tighten the bolt to the specified torque. Refer to [TF-112, "COMPONENTS"](#).

CAUTION:

Install baffle plate by pushing it in the direction shown while tightening the bolt.

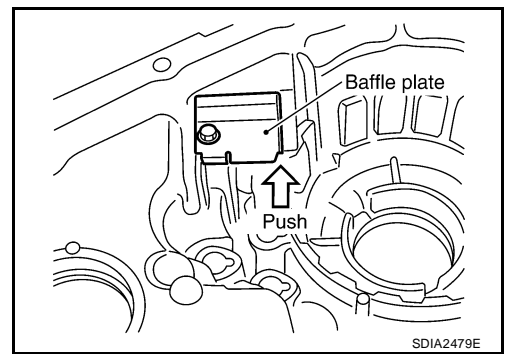

3. Install the input bearing to the front case, using Tool.

Tool number : **ST30720000 (J-25405)**

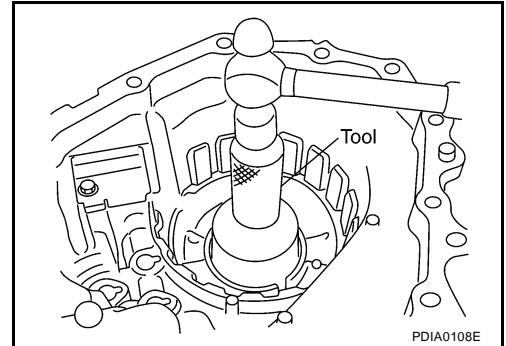

4. Install the new snap ring to the front case.

CAUTION:

Do not reuse snap ring.

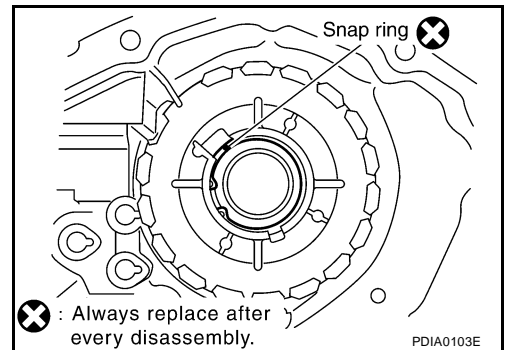

5. Install the internal gear with the groove facing up into the front case.

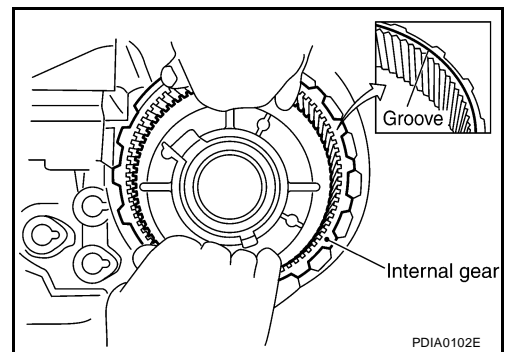

6. Install the new snap ring to the front case.

CAUTION:

Do not reuse snap ring.

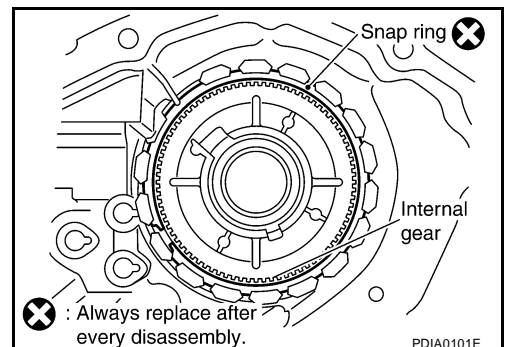

A
B
C
TF
E
F
G
H
I
J
K
L
M

TRANSFER ASSEMBLY

7. Install the planetary carrier assembly and sun gear assembly to the front case, using Tool.

Tool number : KV38100200 (—)

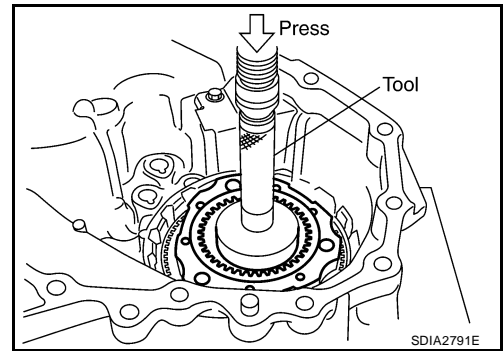

8. Install the new snap ring to the sun gear.

CAUTION:

- Do not reuse snap ring.
- Do not damage sun gear.

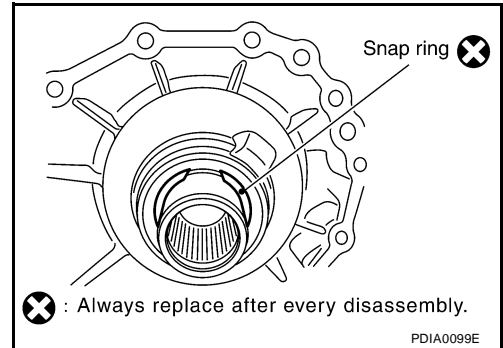

9. Set the L-H sleeve together with the L-H shift fork assembly onto the planetary carrier assembly.

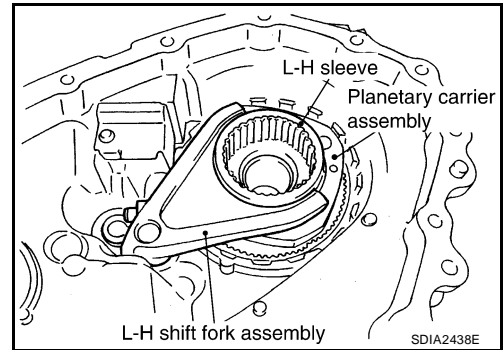

10. Install the control shift rod assembly to the front case.

CAUTION:

Set pin of L-H shift fork assembly into the groove of drum cam.

11. Turn the control shift rod assembly to the fully counterclockwise.

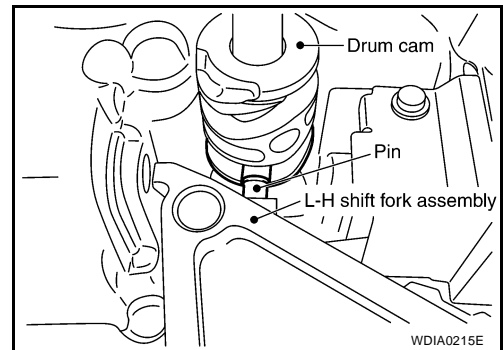

12. Install the L-H shift rod assembly through the L-H shift fork assembly opening to the front case.

CAUTION:

Set pin of L-H shift rod assembly into the groove of drum cam.

13. Install the mainshaft to the sun gear assembly.

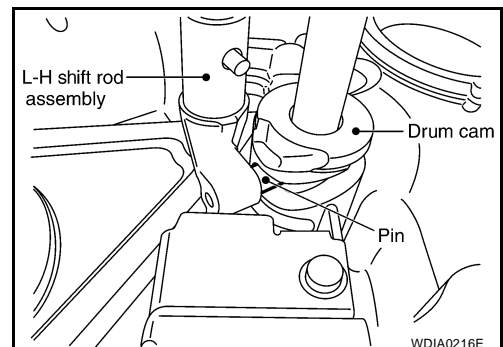

TRANSFER ASSEMBLY

14. Install the drive chain to the front drive shaft and sprocket.

CAUTION:

Install with the Identification mark of drive chain on the side of the rear bearing of front drive shaft.

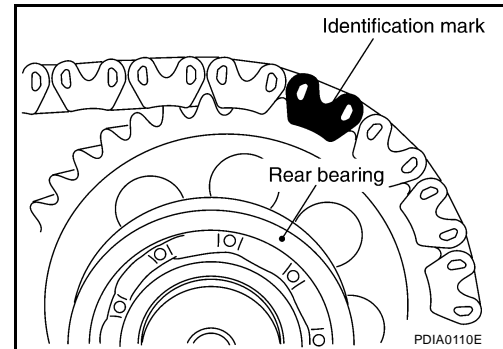

15. Install the drive chain together with the front drive shaft and sprocket to the front case.

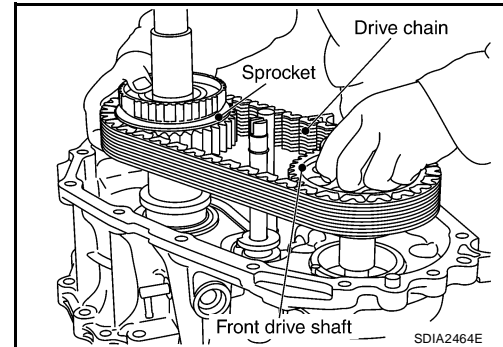

16. Install the 2-4 sleeve and 2-4 shift fork assembly to the mainshaft.

CAUTION:

- Install with proper orientation of 2-4 sleeve.
- Install 2-4 shift fork with engaging the grooves of 2-4 shift fork in the retaining pin of 2-4 shift bracket.

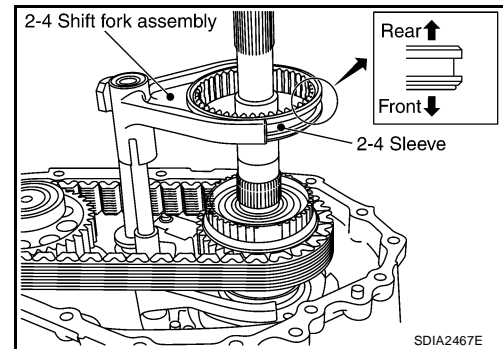

17. Install the new snap ring to the L-H shift rod assembly, using suitable tool.

CAUTION:

Do not reuse snap ring.

18. Install the clutch gear to the mainshaft.

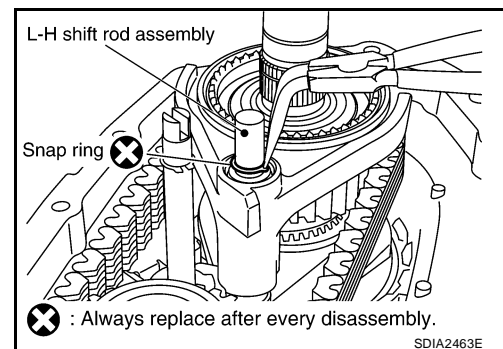

19. Install the new snap ring to the mainshaft, using suitable tool.

CAUTION:

Do not reuse snap ring.

20. Install the oil pump assembly to the mainshaft.

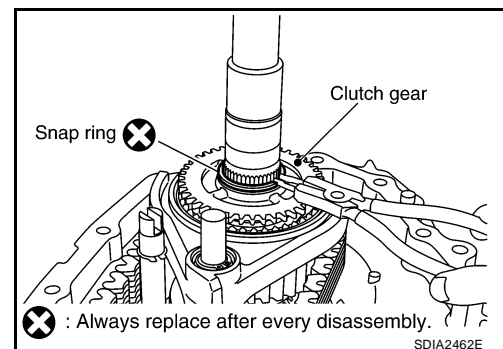

A
B
C
TF
E
F
G
H
I
J
K
L
M

TRANSFER ASSEMBLY

21. Install the new snap ring to the mainshaft, using suitable tool.

CAUTION:
Do not reuse snap ring.

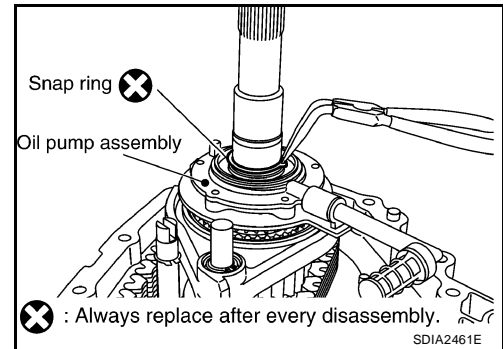

22. Install the retainer to the mainshaft.

CAUTION:
Set the projection of oil pump assembly to the identification hole, and then align locating hole of retainer to the L-H shift rod assembly.

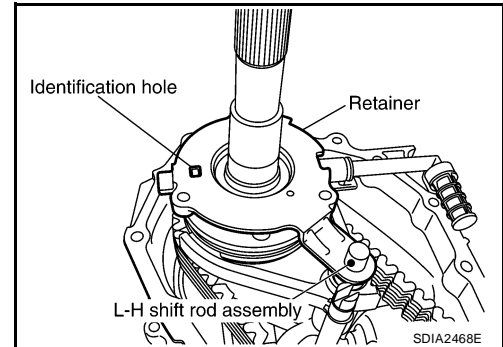

23. Install the mainshaft rear bearing to the mainshaft, using Tool.

Tool number : KV32102700 (—)

CAUTION:
Do not push too hard in order to avoid snap rings becoming dislodged from mainshaft.

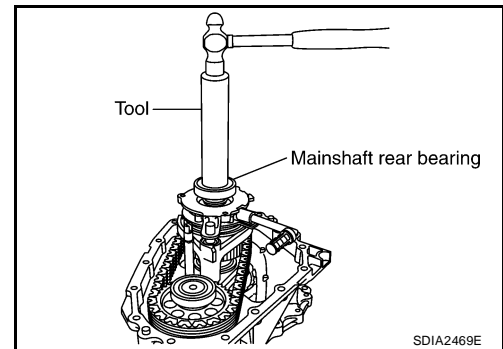

24. Install the new snap ring to the mainshaft, using suitable tool.

CAUTION:
Do not reuse snap ring.

25. Install the spacer to the control shift rod (A/T models only).

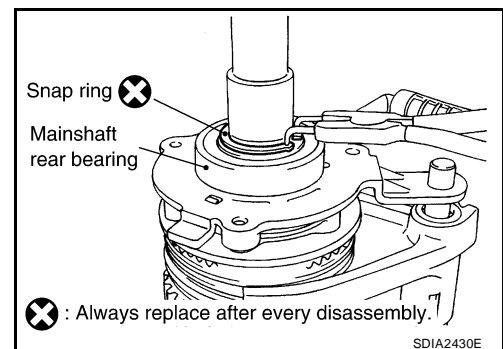

26. Apply liquid gasket to the mating surface of the front case.

- Use Genuine Anaerobic Liquid Gasket or equivalent. Refer to [GI-48, "Recommended Chemical Products and Sealants"](#).

CAUTION:
Remove old sealant adhering to mating surfaces. Also remove any moisture, oil, or foreign material adhering to application and mating surfaces.

27. Install the rear case to the front case.

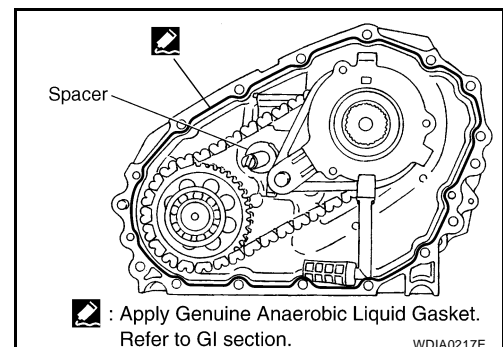

TRANSFER ASSEMBLY

28. Tighten the bolts to the specified torque. Refer to [TF-112, "COMPONENTS"](#) .

CAUTION:

Be sure to install the harness brackets and air breather hose clamp.

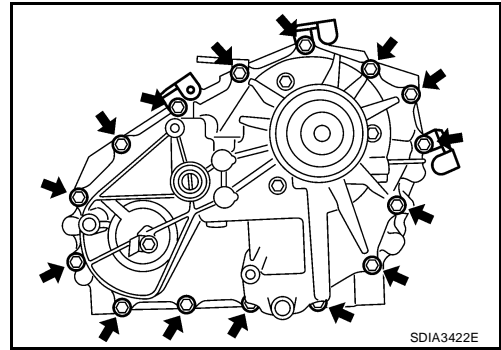

29. Install the retainer bolts with new gaskets. Tighten the bolts to the specified torque. Refer to [TF-112, "COMPONENTS"](#) .

CAUTION:

- Do not reuse gasket.
- Tighten them to the specified torque again.

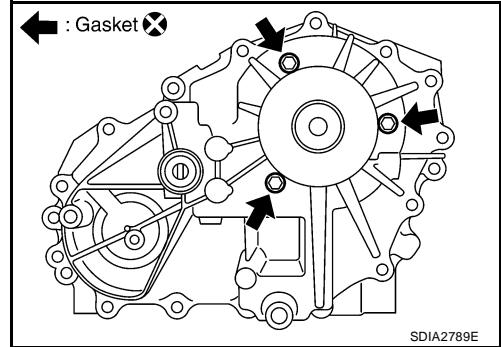

30. Apply petroleum jelly to the circumference of the new oil seal, and install it to the front case, using Tools.

Tool number **A: ST30720000 (J-25405)**
 B: KV40104830 (—)

Dimension A **: 4.0 - 4.6 mm (0.157 - 0.181 in)**

CAUTION:

- Do not reuse oil seal.
- Apply petroleum jelly to oil seal.

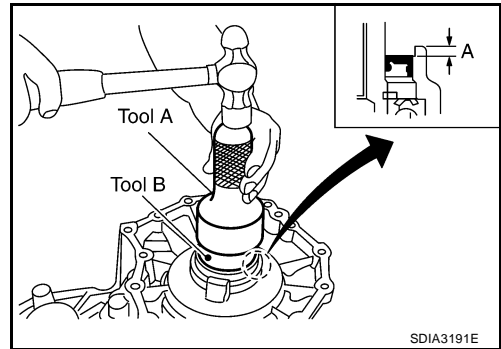

31. Install the new rear oil seal until it is flush with the end face of the rear case, using Tool.

Tool number **: KV38100500 (—)**

CAUTION:

- Do not reuse oil seal.
- Apply petroleum jelly to oil seal.

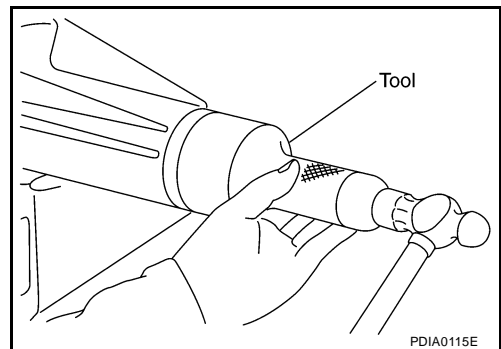

32. Apply petroleum jelly to the circumference of the new dust cover. Position the dust cover using the identification mark as shown.

CAUTION:

- Do not reuse dust cover.
- Position the identification mark at the position shown.

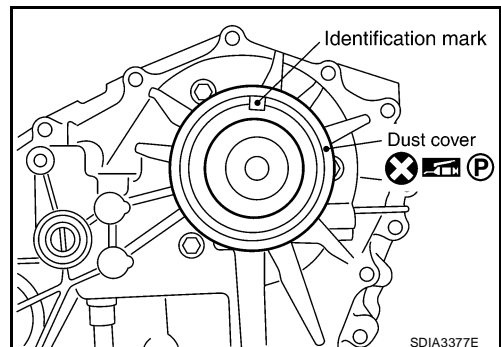

A
B
C
TF
E
F
G
H
I
J
K
L
M

TRANSFER ASSEMBLY

33. Install the new dust cover to the rear case, using Tool.

Tool number : KV40105310 (—)

CAUTION:

- Do not reuse dust cover.
- Apply petroleum jelly to dust cover.

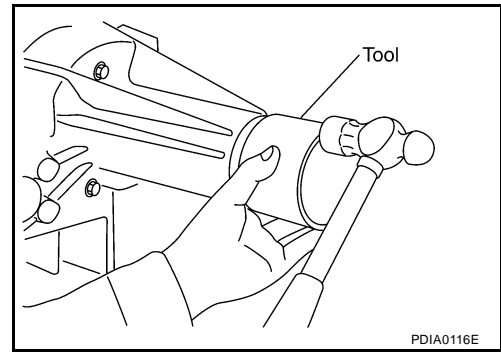

34. Install check ball and check spring to rear case (M/T models only).

35. Apply sealant to thread of check plug, then install it to rear case and tighten to the specified torque (M/T models only). Refer to [TF-112, "COMPONENTS"](#).

- Use Genuine Silicone RTV or equivalent. Refer to [GI-48, "Recommended Chemical Products and Sealants"](#).

CAUTION:

Remove old sealant and oil adhering to threads.

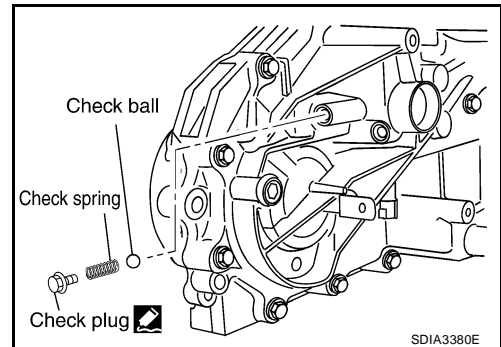

36. Apply sealant to the threads of the wait detection switch (gray). Then install it to the rear case and tighten to the specified torque. Refer to [TF-112, "COMPONENTS"](#).

- Use Genuine Silicone RTV or equivalent. Refer to [GI-48, "Recommended Chemical Products and Sealants"](#).

CAUTION:

Remove old sealant and oil adhering to threads.

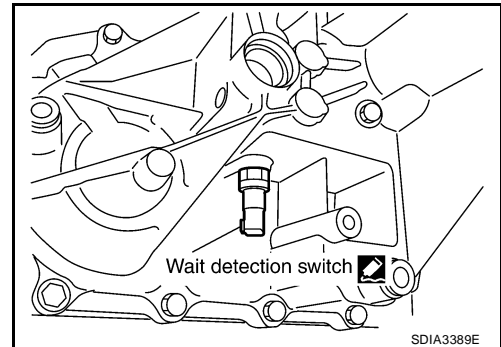

37. Apply sealant to the threads of the 4LO switch (gray with green paint) and ATP switch (black). Then install them to the front case and tighten to the specified torque. Refer to [TF-112, "COMPONENTS"](#).

- Use Genuine Silicone RTV or equivalent. Refer to [GI-48, "Recommended Chemical Products and Sealants"](#).

CAUTION:

Remove old sealant and oil adhering to threads.

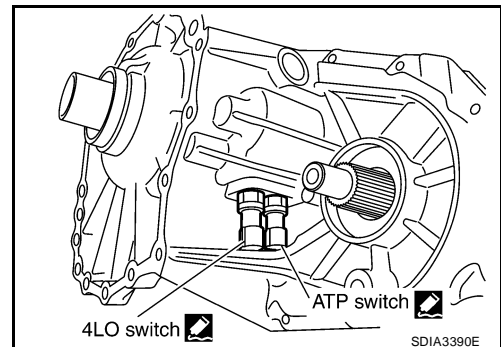

TRANSFER ASSEMBLY

38. Install the new front oil seal until it is flush with the end face of the front case, using Tool.

Tool number : KV38100500 (—)

CAUTION:

- Do not reuse oil seal.
- Apply petroleum jelly to oil seal.

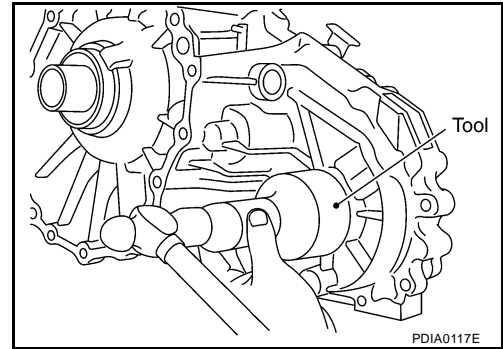

39. Align the matching mark on the front drive shaft with the mark on the companion flange, then install the companion flange.

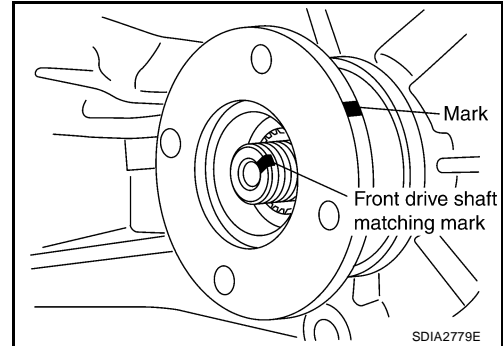

40. Install the new self-lock nut. Tighten to the specified torque, using Tool. Refer to [TF-112, "COMPONENTS"](#).

Tool number : KV40104000 (—)

CAUTION:

- Do not reuse self-lock nut.

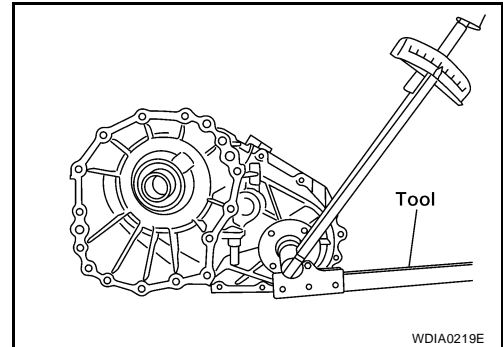

41. Install the new O-ring to the transfer control device.

CAUTION:

- Do not reuse O-ring.
- Apply petroleum jelly to O-ring.

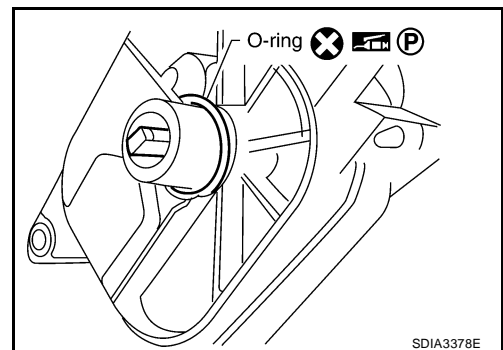

42. Install the transfer control device to the rear case.
- a. Turn the control shift rod fully counterclockwise using suitable tool, and then put a mark on the control shift rod.

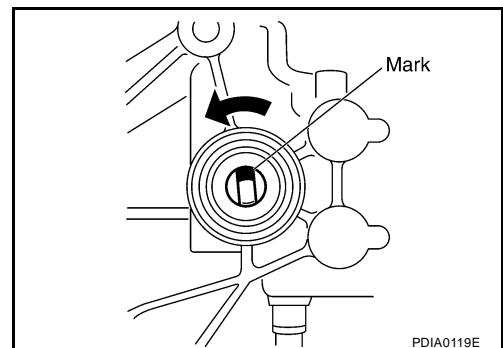

A
B
C
TF
E
F
G
H
I
J
K
L
M

TRANSFER ASSEMBLY

- b. Align the transfer control device shaft cutout with the mark on the control shift rod, and install it.

NOTE:

Turn the transfer control device when the transfer control device connection does not match.

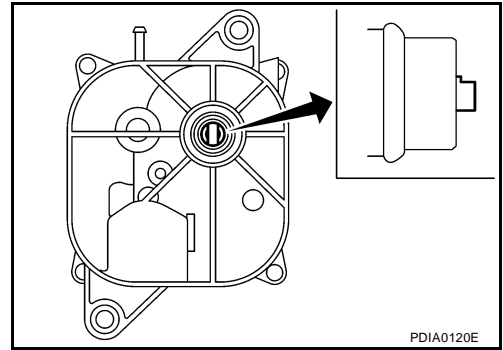

- c. Tighten the bolts to the specified torque. Refer to [TF-112, "COMPONENTS"](#).

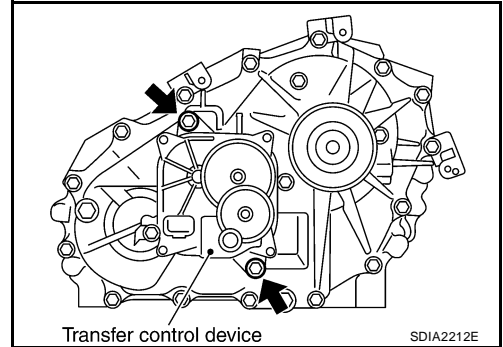

43. Install the drain plug and filler plug with new gaskets to the rear case. Tighten to the specified torque. Refer to [TF-112, "COMPONENTS"](#).

CAUTION:

Do not reuse gaskets.

PLANETARY CARRIER

PFP:33113

EDS002NI

PLANETARY CARRIER

Disassembly and Assembly

1. Remove the snap ring.
2. Remove the sun gear assembly from the planetary carrier assembly, using suitable tool.

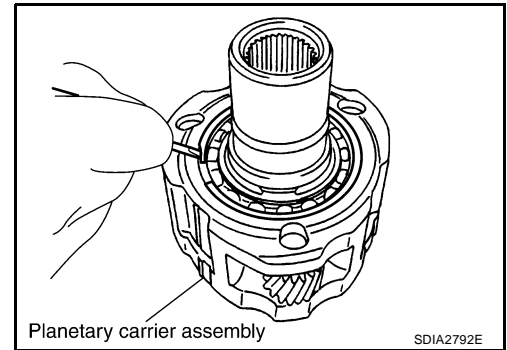

3. Remove the snap ring from the sun gear assembly, using suitable tool.

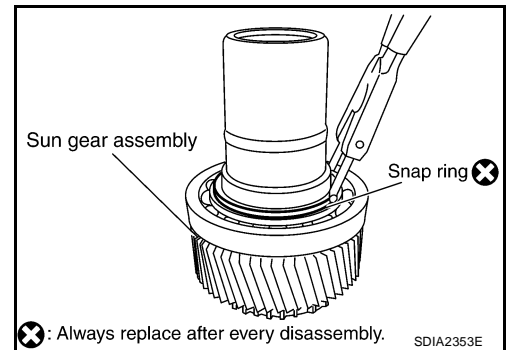

4. Remove the carrier bearing from the sun gear, using Tools.

Tool number **A: ST35300000 (—)**
B: ST30021000 (J-22912-01)

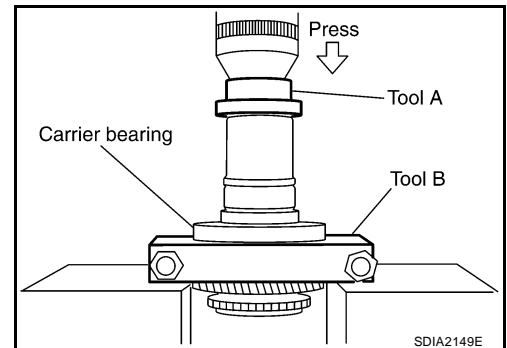

5. Remove the needle bearing from the sun gear, using Tool.

Tool number **: ST33710000 (—)**

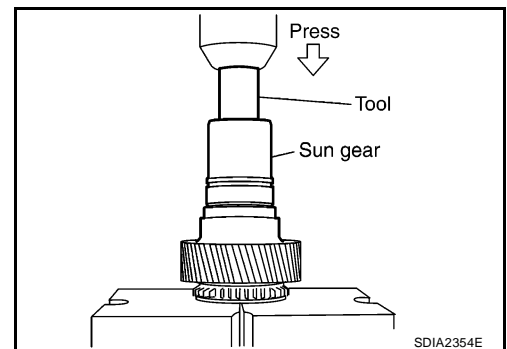

A
B
C
TF
E
F
G
H
I
J
K
L
M

PLANETARY CARRIER

6. Remove the metal bushing from the sun gear, using Tools.

Tool number **A: ST33710000 (—)**
 B: ST35325000 (—)
 C: KV381054S0 (J-34286)

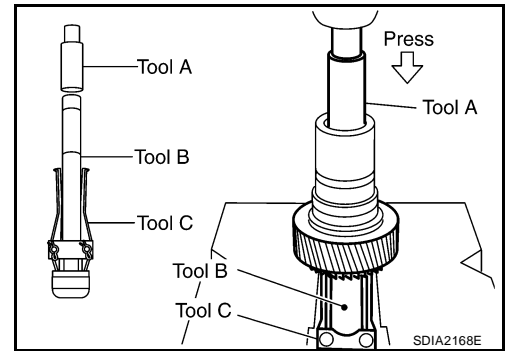

INSPECTION AFTER DISASSEMBLY

Bearing

Check the bearing for damage and rough rotation. If necessary, replace the bearing with a new one.

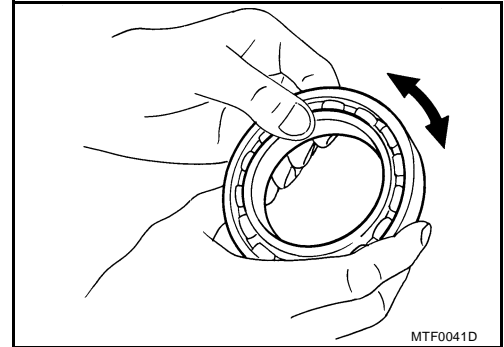

Planetary Carrier

- Measure the end play of each pinion gear. If it is out of specification, replace the planetary carrier assembly with new one.

Pinion gear end play : 0.1 - 0.7 mm (0.004 - 0.028 in)

- Check the working face of each gear and bearing for damage, burrs, partial wear, dents and other abnormality. If any is found, replace the planetary carrier assembly with a new one.

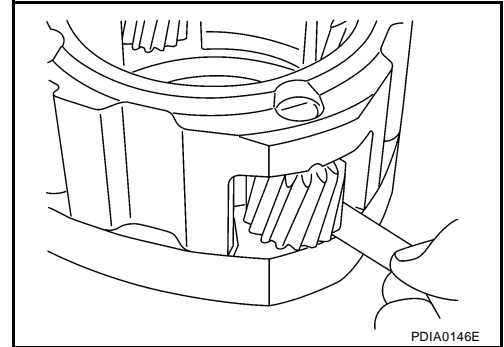

Sun Gear

- Check if the oil passage of the sun gear assembly is clogged. For this, try to pass a 3.6 mm (0.142 in) dia. wire through the oil passage as shown.
- Check the sliding and contact surface of each gear and bearing for damage, burrs, partial wear, dents and other abnormality. If any is found, replace the sun gear assembly with a new one.

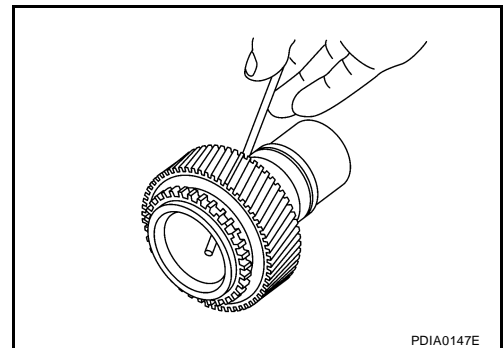

PLANETARY CARRIER

Internal Gear

Check the internal gear teeth for damage, partial wear, dents or other abnormality. If any is found, replace the internal gear with a new one.

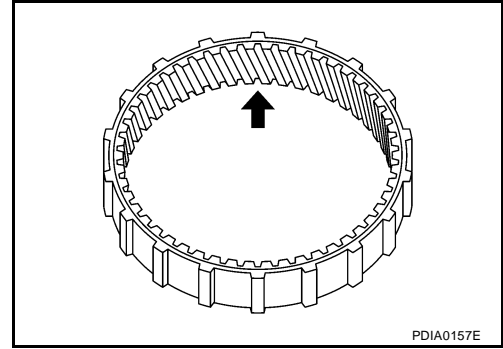

A
B
C
TF

ASSEMBLY

1. Apply ATF to the metal bushing, then install the metal bushing until it becomes "Dimension A", using Tool.

Tool number : ST35300000 (—)

Dimension A : 7.7 - 8.3mm (0.303 - 0.327in)

CAUTION:

Do not reuse metal bushing.

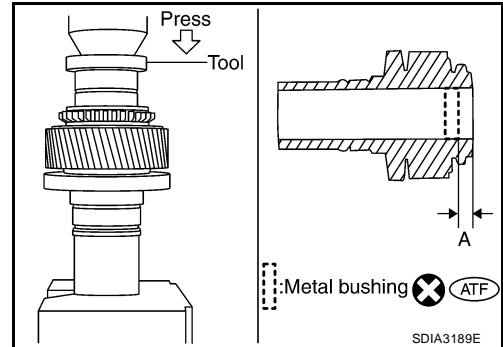

E
F
G
H

2. Apply ATF to the needle bearing, then install the needle bearing until it becomes "Dimension B", using Tool.

Tool number : ST33220000 (—)

Dimension B : 62.5 - 63.1mm (2.461 - 2.484in)

CAUTION:

Do not reuse needle bearing.

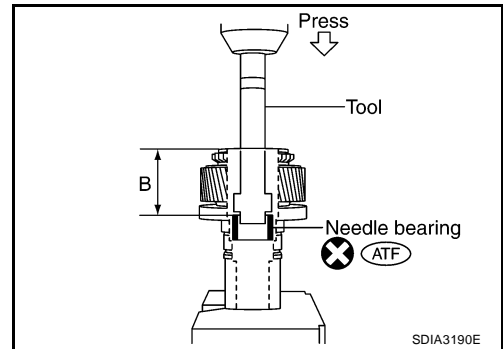

I
J
K
L

3. Install the carrier bearing to the sun gear, using Tools.

Tool number A: ST30720000 (J-25405)

B: ST27863000 (—)

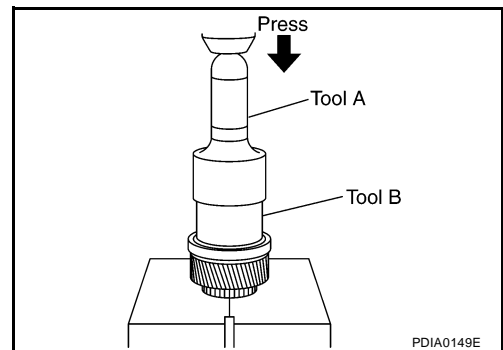

M

PLANETARY CARRIER

4. Install the new snap ring to the sun gear assembly, using suitable tool.

CAUTION:

Do not reuse snap ring.

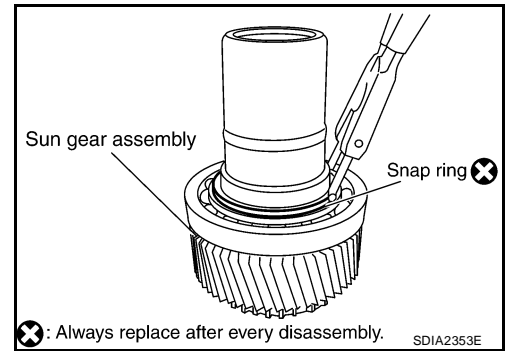

5. Install the sun gear assembly to the planetary carrier assembly.
6. Install the new snap ring to the planetary carrier assembly.

CAUTION:

Do not reuse snap ring.

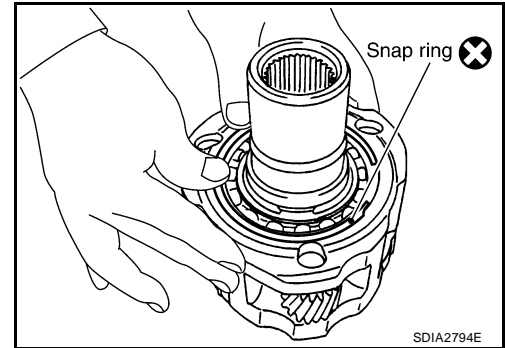

FRONT DRIVE SHAFT

FRONT DRIVE SHAFT

PFP:39100

Disassembly and Assembly DISASSEMBLY

EDS002NJ

1. Remove the front bearing, using Tools.

Tool number **A: ST35300000 (—)**
 B: ST30021000 (J-22912-01)

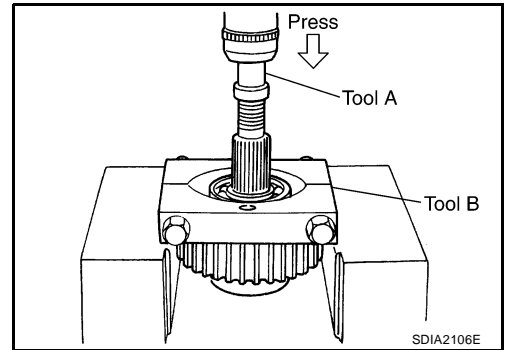

2. Remove the rear bearing, using Tools.

Tool number **A: ST33710000 (—)**
 B: ST30021000 (J-22912-01)

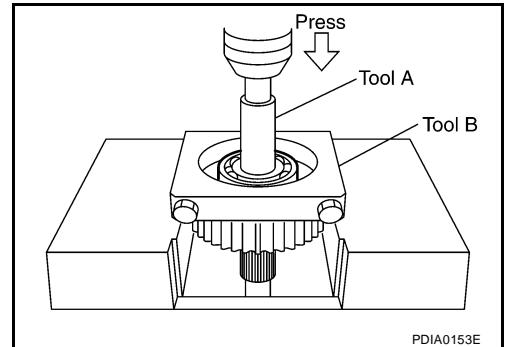

INSPECTION AFTER DISASSEMBLY

Front Drive Shaft

Check the items below. If necessary, replace them with new ones.

- Damage, peeling, dent, uneven wear and bending of the shaft.
- Excessive wear, damage and peeling of the gear.

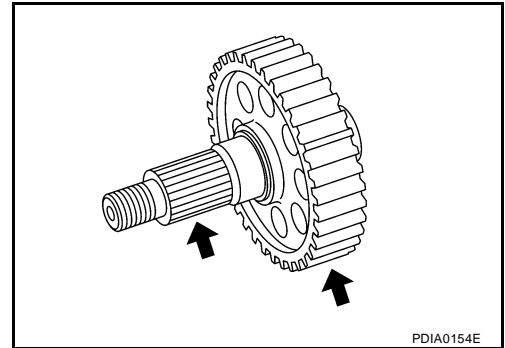

Bearing

Check the bearing for damage and rough rotation. If necessary, replace the bearing with a new one.

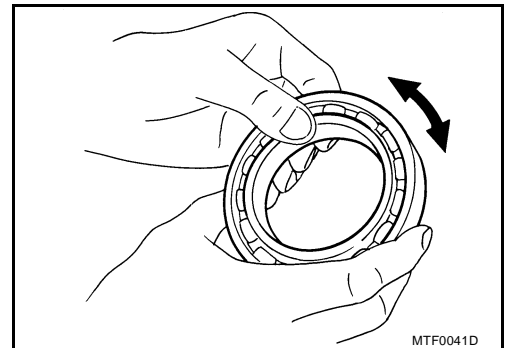

A
B
C
TF
E
F
G
H
I
J
K
L
M

FRONT DRIVE SHAFT

ASSEMBLY

1. Install the rear bearing, using Tools.

Tool number **A: KV38100500 (—)**
 B: ST30901000 (J-26010-01)

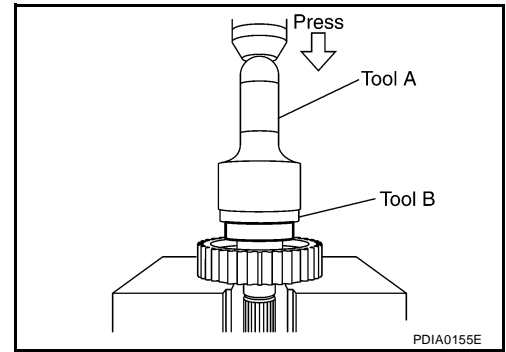

2. Install the front bearing, using Tools.

Tool number **A: KV38100500 (—)**
 B: ST30901000 (J-26010-01)

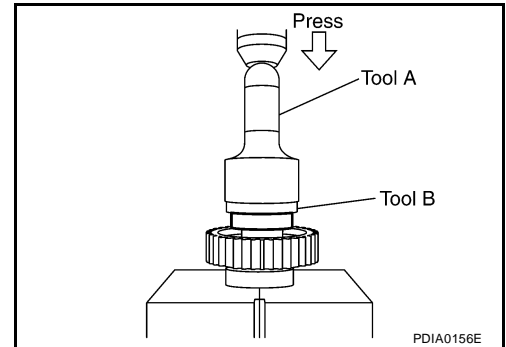

SHIFT CONTROL

SHIFT CONTROL

PFP:33167

EDS002NK

Disassembly and Assembly DISASSEMBLY (A/T MODELS)

1. Remove the snap ring.
2. Remove the retaining pin.
3. Remove the drum cam from the control shift rod.

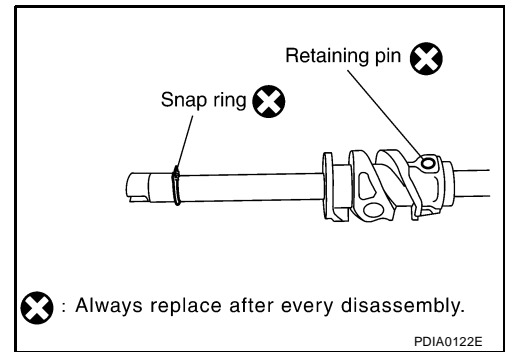

4. Remove the retaining pin from the L-H shift rod.
5. Remove the 2-4 shift bracket.

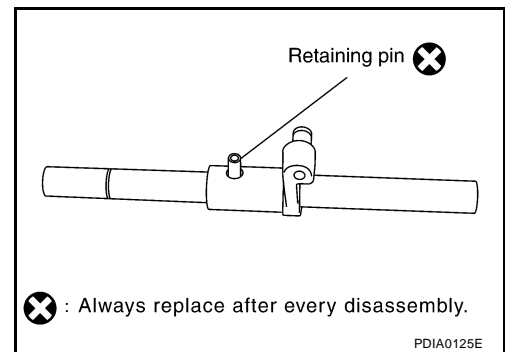

6. Remove the retaining ring from the 2-4 shift fork, using suitable tool.
7. Remove the fork guide collar and 2-4 shift fork spring from the 2-4 shift fork.

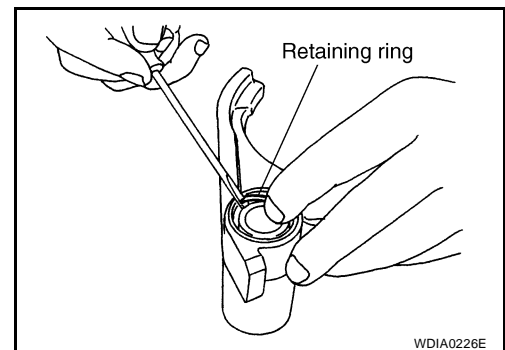

DISASSEMBLY (M/T MODELS)

1. Remove the retaining ring from the 2-4 shift fork, using suitable tool.
2. Remove the fork guide collar and 2-4 shift fork spring from the 2-4 shift fork.

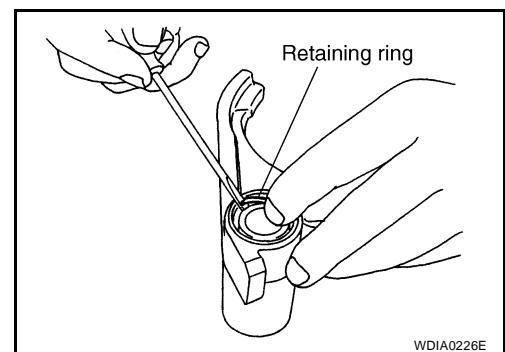

A
B
C
TF
E
F
G
H
I
J
K
L
M

SHIFT CONTROL

INSPECTION AFTER DISASSEMBLY

Shift Fork

- Measure the clearance between the shift fork and sleeve. If it is out of specification, replace it with a new one.

Standard value

2-4 : Less than 0.46 mm (0.018 in)

L-H : Less than 0.46 mm (0.018 in)

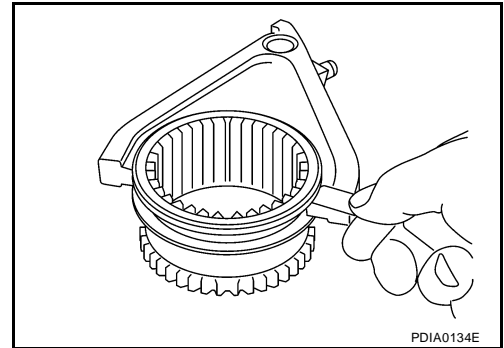

Shift Rod and Fork Components

- Check the working face of the shift rod and fork for wear, partial wear, abrasion, bending and other abnormality. If any is found, replace with a new one.

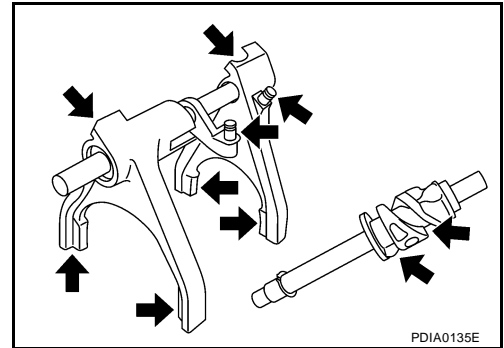

ASSEMBLY (A/T MODELS)

1. Install clevis pin and shift collar to L-H shift fork after assembling them.

CAUTION:

Use caution when installing L-H shift fork, clevis pin or shift collar.

2. Install clevis pin and shift collar to 2-4 shift bracket after assembling them.

CAUTION:

Use caution when installing 2-4 shift bracket.

3. Install fork guide collar and 2-4 shift fork spring to the 2-4 shift fork, and then secure it with the new retaining ring.

CAUTION:

- Do not reuse retaining ring.
- Be careful with orientation.

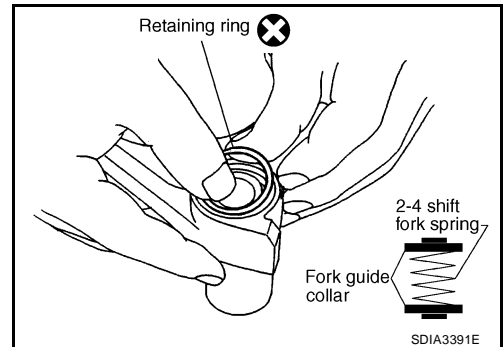

4. Install the 2-4 shift bracket to the L-H shift rod.
5. Install the new retaining pin evenly to the L-H shift rod.

CAUTION:

Do not reuse retaining pin.

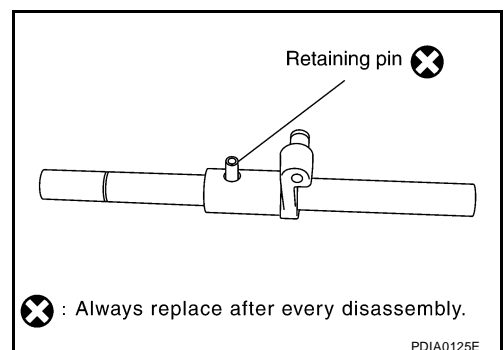

SHIFT CONTROL

6. Install the drum cam to the control shift rod, and then secure it with the new retaining pin.

CAUTION:

Do not reuse retaining pin.

7. Install the new snap ring to the control shift rod.

CAUTION:

Do not reuse snap ring.

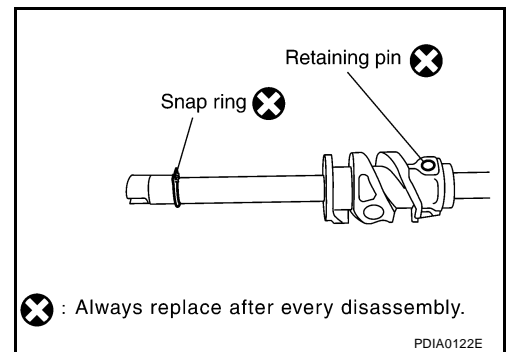

ASSEMBLY (M/T MODELS)

1. Install clevis pin and shift collar to L-H shift fork after assembling them.

CAUTION:

Use caution when installing L-H shift fork, clevis pin or shift collar.

2. Install clevis pin and shift collar to 2-4 shift bracket after assembling them.

CAUTION:

Use caution when installing 2-4 shift bracket.

3. Install the fork guide collar and 2-4 shift fork spring to the 2-4 shift fork, and then secure it with the new retaining ring.

CAUTION:

- Do not reuse retaining ring.
- Be careful with orientation.

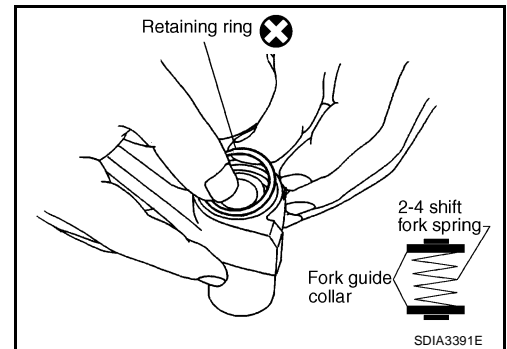

A
B
C
TF

E
F
G
H
I
J
K
L
M

SERVICE DATA AND SPECIFICATIONS (SDS)

SERVICE DATA AND SPECIFICATIONS (SDS)

PF0:00030

General Specifications

EDS002NL

Engine		VQ40DE	
Transfer model		TX15B	
Fluid capacity (Approx.)		ℓ (US qt, Imp qt)	
		2.0 (2-1/8, 1-3/4)	
Gear ratio	High	1.000	
	Low	2.625	
Number of teeth	Planetary gear	Sun gear	56
		Internal gear	91
	Front drive sprocket		38
	Front drive shaft		38

Inspection and Adjustment PINION GEAR END PLAY

EDS002NM

Unit: mm (in)

Item	Standard
Pinion gear end play	0.1 - 0.7 (0.004 - 0.028)

CLEARANCE BETWEEN SHIFT FORK AND SLEEVE

Unit: mm (in)

Item	Standard
2-4 shift fork to 2-4 sleeve	Less than 0.46 (0.018)
L-H shift fork to L-H sleeve	Less than 0.46 (0.018)