

SECTION **PB**
PARKING BRAKE SYSTEM

A
B
C
D
E
PB
G
H
I
J
K
L
M
N
O
P

CONTENTS

PREPARATION	2	Removal and Installation	5
PREPARATION	2	PARKING BRAKE SHOE	6
Commercial Service Tool	2	Exploded View	6
ON-VEHICLE REPAIR	3	Removal and Installation	6
PARKING BRAKE SYSTEM	3	SERVICE DATA AND SPECIFICATIONS	
On-Vehicle Service	3	(SDS)	9
REMOVAL AND INSTALLATION	4	SERVICE DATA AND SPECIFICATIONS	
PARKING BRAKE CONTROL	4	(SDS)	9
Exploded View	4	Parking Drum Brake	9
		Parking Brake Control	9

PREPARATION



< PREPARATION >

PREPARATION

PREPARATION

Commercial Service Tool

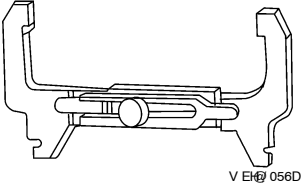
INFOID:000000004064646

(Kent-Moore No.) Tool name		Description
(J-21177-A) Brake drum clearance gauge	 <p>V E H 056D</p>	Measuring rear rotor drum to parking brake shoe clearance
Power tool	 <p>CHM.03/ 6D</p>	Removing bolts and nuts

PARKING BRAKE SYSTEM

< ON-VEHICLE REPAIR >

ON-VEHICLE REPAIR

PARKING BRAKE SYSTEM

On-Vehicle Service

INFOID:000000004064647

LEVER STROKE

- When parking brake lever is operated with the specified force, make sure the stroke is within the specified number of notches. Check by listening and counting the ratchet clicks.

Lever stroke : Refer to [PB-9, "Parking Brake Control"](#).

INSPECTION

- Check that the components are attached properly, check for looseness or backlash.
- Check the parking brake lever assembly for bends, damage and cracks, and replace if necessary.
- Check the cables for wear and damage, and replace if necessary.
- Check the parking brake warning lamp switch for any malfunction, and repair if necessary. Refer to [BCS-3, "ADDITIONAL SERVICE WHEN REPLACING CONTROL UNIT : Description"](#).

ADJUSTMENT

1. Remove the rear half of the center console. Refer to [IP-18, "Disassembly and Assembly"](#).
2. Rotate the adjusting nut to loosen the cable until the cable tension is sufficiently released.

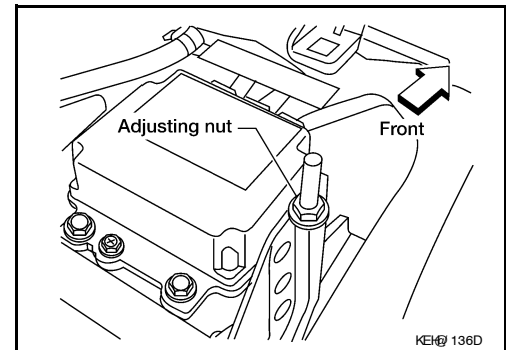

3. Remove the wheel and tire. Refer to [WT-46, "Rotation"](#).
4. Remove the rear disc rotor and measure the inner diameter of the parking brake drum at the widest point using a suitable tool as shown.
5. Transfer the measurement less 0.6 mm (0.024 in) to the parking brake shoes and adjust them accordingly.
6. Using the wheel nuts, secure the rear disc rotor to the hub to prevent it from tilting.
7. Rotate the rear disc rotor to make sure there is no drag.
8. Adjust the parking brake cables as follows:
 - a. Operate the parking brake lever 10 or more times with a force of 490 N (50 kg-f, 110 lb-f).
 - b. Rotate the adjusting nut to adjust the parking brake lever stroke to specification.

Lever stroke : Refer to [PB-9, "Parking Brake Control"](#).

- c. With the parking brake lever completely disengaged, make sure there is no drag on the parking brakes.

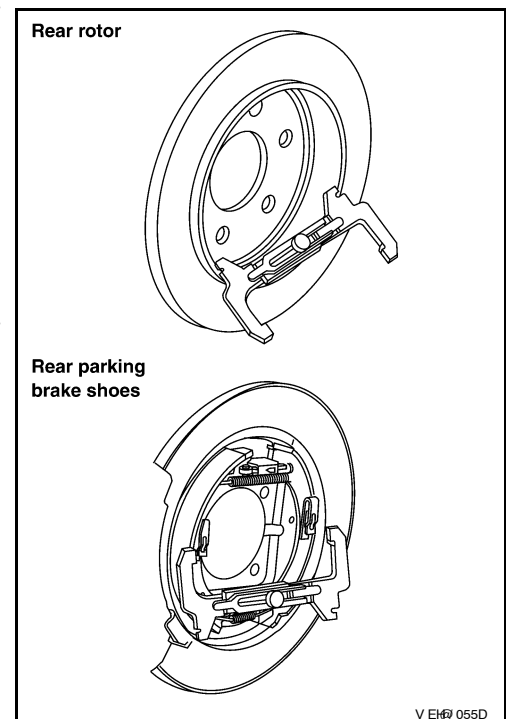

PARKING BRAKE CONTROL

< REMOVAL AND INSTALLATION >

REMOVAL AND INSTALLATION

PARKING BRAKE CONTROL

Exploded View

INFOID:000000004064648

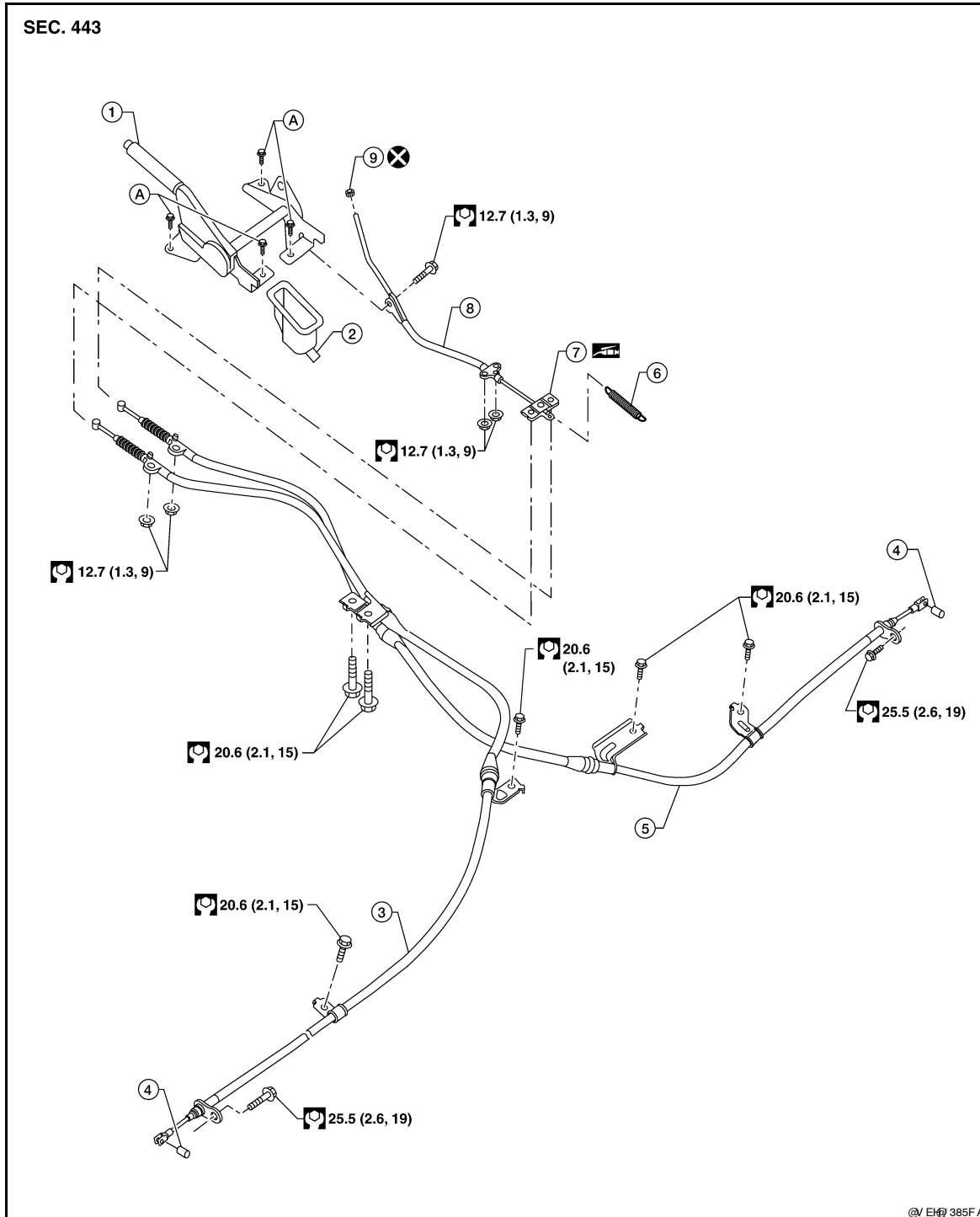

PARKING BRAKE CONTROL

< REMOVAL AND INSTALLATION >

Removal and Installation

INFOID:000000004064649

REMOVAL

1. Disconnect the return spring from the equalizer.
2. Remove the right and left rear cables from the equalizer.
3. Remove the front cable nuts from underneath the vehicle.
4. Remove the rear half of the center console. Refer to [IP-18, "Disassembly and Assembly"](#).
5. Remove the four control lever assembly bolts, then remove the control lever assembly.
6. Remove the front cable grommet from the control lever assembly.
7. Remove the front cable to control lever assembly bolt.
8. Remove the adjusting nut and discard, then remove the front cable.
CAUTION:
Do not reuse the adjusting nut, use a new adjusting nut for installation.
9. Remove the rear disc rotors. Refer to [BR-38, "Removal and Installation of Brake Caliper and Disc Rotor"](#).
10. Remove the left and right parking brake shoes, then disconnect the rear cables from the toggle levers.
11. Remove the left and right rear cable bolts and nuts, then remove the left and right rear cables.

INSTALLATION

Installation is in the reverse order of removal.

- The control lever assembly bolts must be installed in the following order:

Control lever assembly bolts : 12.7 N·m (1.3 kg-m, 9 ft-lb)

1. Install and temporarily tighten the control lever assembly bolts (A), (B) and (D).
2. Install and tighten the control lever assembly bolt (C) to specification.
3. Tighten the control lever assembly bolt (D) to specification.
4. Tighten the control lever assembly bolt (A) to specification.
5. Tighten the control lever assembly bolt (B) to specification.

- Adjust the parking brake. Refer to [PB-3, "On-Vehicle Service"](#).

CAUTION:

- **Do not reuse the adjusting nut, use a new adjusting nut for installation.**
- **Install the control lever assembly bolts in the specified order and pattern.**

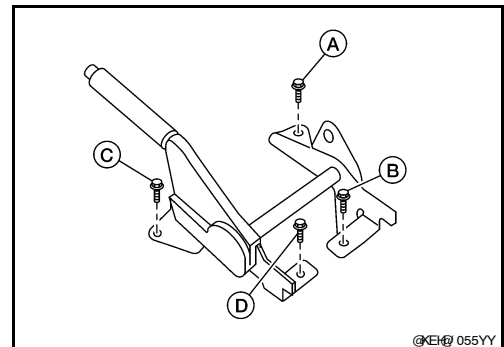

PARKING BRAKE SHOE

< REMOVAL AND INSTALLATION >

PARKING BRAKE SHOE

Exploded View

INFOID:000000004064650

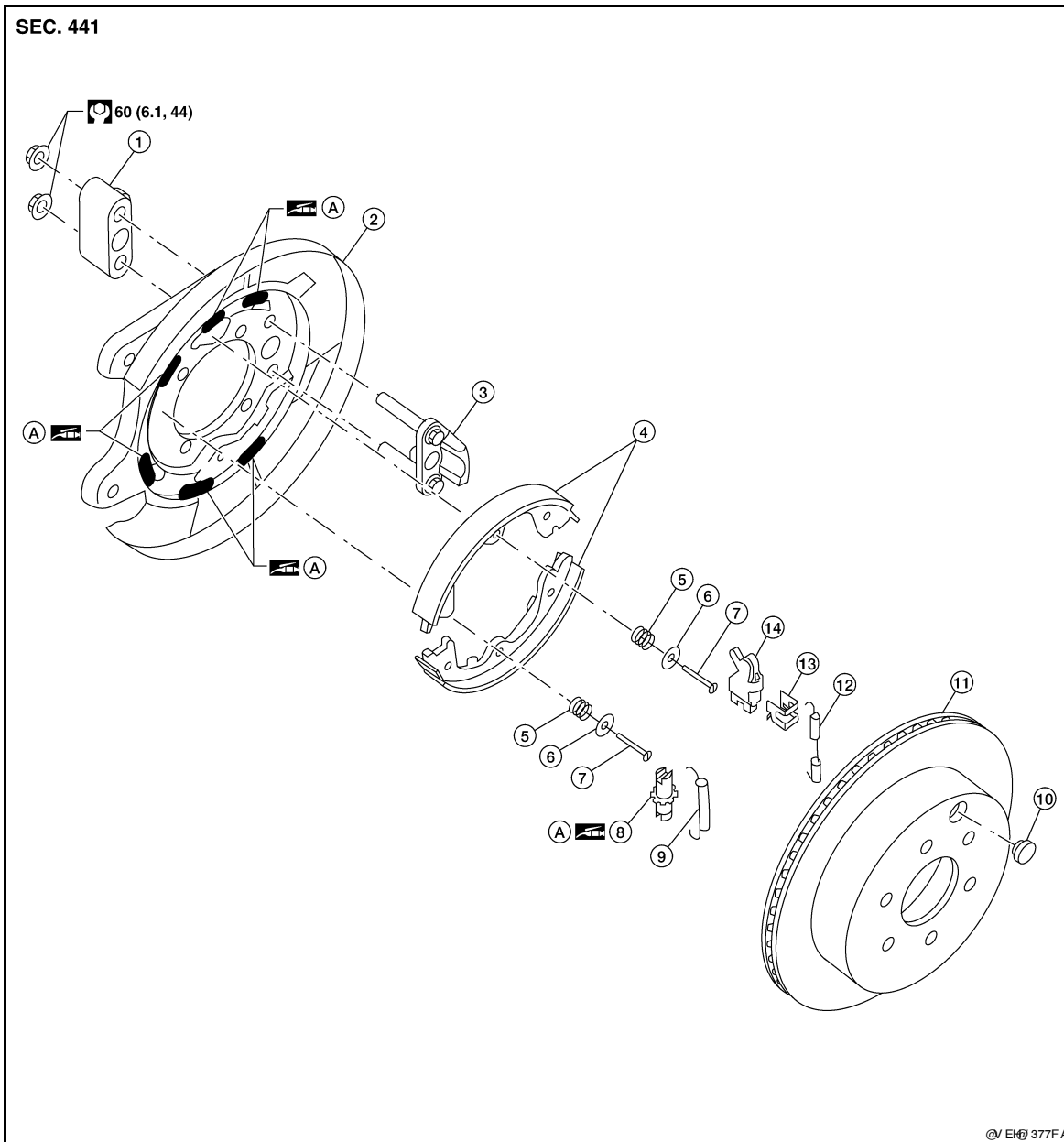

- | | | |
|--------------------------|--------------------------|-------------------------------------|
| 1. Anchor block | 2. Back plate | 3. Anchor |
| 4. Shoes | 5. Shoe hold-down spring | 6. Retainer |
| 7. Shoe hold-down pin | 8. Adjuster | 9. Rear return spring |
| 10. Adjuster access plug | 11. Disc rotor | 12. Front return spring |
| 13. Pin retainer | 14. Toggle lever | A. PBC (Poly Butyl Cuprysil) grease |

Removal and Installation

INFOID:000000004064651

REMOVAL

WARNING:

Clean the brakes with a vacuum dust collector to minimize the hazard of airborne particles or other materials.

NOTE:

PARKING BRAKE SHOE

< REMOVAL AND INSTALLATION >

Remove the disc rotor only with the parking brake lever completely disengaged.

1. Remove the rear disc rotor. Refer to [BR-38, "Removal and Installation of Brake Caliper and Disc Rotor"](#).
2. Remove the return springs.
3. Remove the adjuster.
4. Remove the retainers, anti-rattle pins and shoes.
5. Remove the pin retainer, then disconnect the parking brake cable from the toggle lever.
6. Remove the back plate.

INSPECTION AFTER REMOVAL

Lining Thickness Inspection

- Check the thickness of the shoe lining.

Standard thickness (A) :Refer to [PB-9, "Parking Drum Brake"](#).

Wear limit thickness (A) :Refer to [PB-9, "Parking Drum Brake"](#).

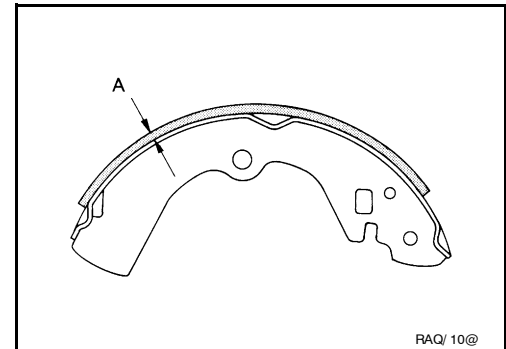

Drum Inner Diameter Inspection

- Check the drum inner diameter.

Standard inner diameter :Refer to [PB-9, "Parking Drum Brake"](#).

Wear limit of inner diameter :Refer to [PB-9, "Parking Drum Brake"](#).

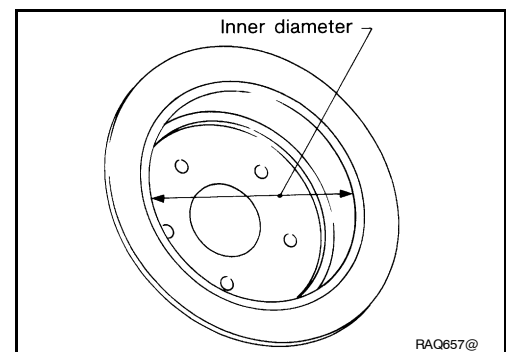

Other Inspections

- Check the shoe sliding surface for excessive wear and damage.
- Check the shoe anti-rattle pin for excessive wear and corrosion.
- Check the front and rear return springs for sagging.
- Check the adjuster for rough operation.
- When disassembling adjuster, apply PBC (Poly Butyl Cuprysil) grease or equivalent to the adjuster threads.
- Check either visually or with a vernier caliper for any excessive wear, cracks, or damage inside the drum.

INSTALLATION

Installation is in the reverse order of removal.

- Apply brake grease to the back plate at the specified points during installation.
- Install the adjuster so that the threaded part expands when rotating it in the direction shown by the arrow.
- Shorten adjuster by rotating it in the opposite direction.

NOTE:

After replacing the shoes or disc rotors, or if parking brake does not function properly, perform the break-in operation as follows.

1. Adjust the parking brake lever stroke to specification. Refer to [PB-3, "On-Vehicle Service"](#).

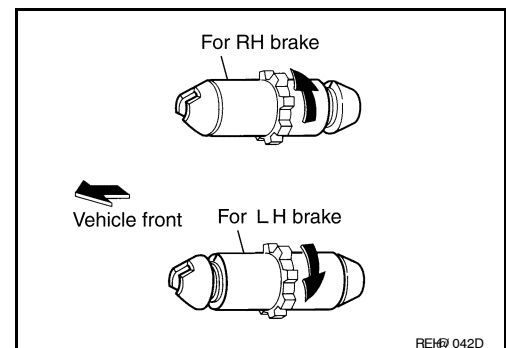

2. Perform the parking brake break-in operation by driving the vehicle forward under the following conditions:

PARKING BRAKE SHOE

< REMOVAL AND INSTALLATION >

- Maintain vehicle speed at 40 km/h (25 MPH) moving forward.
- Apply the parking brake control lever with an operating force of 196 N (20.0 kg-f, 44.1 lb-f).
- Apply the parking brake control lever for a period of 30 seconds before releasing.

CAUTION:

- **To prevent lining from getting too hot, allow a cool off period of approximately 5 minutes after every break-in operation.**
 - **Do not perform excessive break-in operations, because it may cause uneven or early wear of lining.**
3. After the break-in operation, check parking brake control lever stroke. Readjust as necessary if it is not within the specified stroke. Refer to [PB-3. "On-Vehicle Service"](#).

SERVICE DATA AND SPECIFICATIONS (SDS)

< SERVICE DATA AND SPECIFICATIONS (SDS)

SERVICE DATA AND SPECIFICATIONS (SDS)

SERVICE DATA AND SPECIFICATIONS (SDS)

Parking Drum Brake

INFOID:000000004064652

Unit: mm (in)

Type		Drum
Brake lining	Standard thickness (new)	3.8 ± 0.15 (0.150 ± 0.006)
	Wear limit thickness	0.5 (0.020)
Drum inner diameter (disc)	Standard inner diameter (new)	190 + 0.15/- 0.00 (7.480 + 0.006/- 0.000)
	Wear limit of inner diameter	XXXXX (XXXXX)

Parking Brake Control

INFOID:000000004064653

Control type	Control lever
Number of notches [under force of 196 N (20.0 kg-f, 44.1 lb-f)]	6 – 8 notches
Number of notches when warning lamp switch comes on	1 notch