

A  
LU  
C  
D  
E  
F  
G  
H  
I  
J  
K  
L  
M  
N  
O  
P

# SECTION LU

## ENGINE LUBRICATION SYSTEM

### CONTENTS

<b>VQ40DE</b>	Changing Engine Oil .....	8
<b>PRECAUTION</b> .....	<b>OIL FILTER</b> .....	10
	Removal and Installation .....	10
<b>PRECAUTIONS</b> .....	<b>ON-VEHICLE REPAIR</b> .....	11
Precaution for Supplemental Restraint System (SRS) "AIR BAG" and "SEAT BELT PRE-TEN- SIONER" .....	<b>OIL COOLER</b> .....	11
Precaution for Liquid Gasket .....	Exploded View .....	11
	Removal and Installation .....	11
<b>PREPARATION</b> .....	<b>OIL PUMP</b> .....	13
	Exploded View .....	13
<b>PREPARATION</b> .....	Removal and Installation .....	13
Special Service Tool .....	<b>DISASSEMBLY AND ASSEMBLY</b> .....	14
Commercial Service Tool .....	<b>OIL PUMP</b> .....	14
<b>FUNCTION DIAGNOSIS</b> .....	Disassembly and Assembly .....	14
<b>LUBRICATION SYSTEM</b> .....	<b>SERVICE DATA AND SPECIFICATIONS (SDS)</b> .....	16
Lubrication Circuit .....	<b>SERVICE DATA AND SPECIFICATIONS (SDS)</b> .....	16
System Chart .....	Standard and Limit .....	16
<b>ON-VEHICLE MAINTENANCE</b> .....		
<b>ENGINE OIL</b> .....		
Inspection .....		

PRECAUTION

PRECAUTIONS

Precaution for Supplemental Restraint System (SRS) "AIR BAG" and "SEAT BELT PRE-TENSIONER"

INFOID:000000005774513

The Supplemental Restraint System such as "AIR BAG" and "SEAT BELT PRE-TENSIONER", used along with a front seat belt, helps to reduce the risk or severity of injury to the driver and front passenger for certain types of collision. This system includes seat belt switch inputs and dual stage front air bag modules. The SRS system uses the seat belt switches to determine the front air bag deployment, and may only deploy one front air bag, depending on the severity of a collision and whether the front occupants are belted or unbelted. Information necessary to service the system safely is included in the SR and SB section of this Service Manual.

**WARNING:**

- To avoid rendering the SRS inoperative, which could increase the risk of personal injury or death in the event of a collision which would result in air bag inflation, all maintenance must be performed by an authorized NISSAN/INFINITI dealer.
- Improper maintenance, including incorrect removal and installation of the SRS, can lead to personal injury caused by unintentional activation of the system. For removal of Spiral Cable and Air Bag Module, see the SR section.
- Do not use electrical test equipment on any circuit related to the SRS unless instructed to in this Service Manual. SRS wiring harnesses can be identified by yellow and/or orange harnesses or harness connectors.

PRECAUTIONS WHEN USING POWER TOOLS (AIR OR ELECTRIC) AND HAMMERS

**WARNING:**

- When working near the Airbag Diagnosis Sensor Unit or other Airbag System sensors with the Ignition ON or engine running, DO NOT use air or electric power tools or strike near the sensor(s) with a hammer. Heavy vibration could activate the sensor(s) and deploy the air bag(s), possibly causing serious injury.
- When using air or electric power tools or hammers, always switch the Ignition OFF, disconnect the battery, and wait at least 3 minutes before performing any service.

Precaution for Liquid Gasket

INFOID:000000005281590

REMOVAL OF LIQUID GASKET SEALING

- After removing the bolts and nuts, separate the mating surface and remove the old liquid gasket sealing using Tool.

**Tool number : KV10111100 (J-37228)**

**CAUTION:**

**Do not damage the mating surfaces.**

- Tap (1) the Tool to insert it.
- In areas where the Tool is difficult to use, lightly tap to slide (2) it.

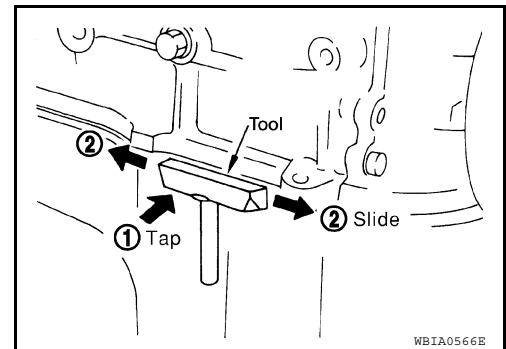

LIQUID GASKET APPLICATION PROCEDURE

# PRECAUTIONS

[VQ40DE]

## < PRECAUTION >

1. Remove the old liquid gasket adhering to the gasket application surface and the mating surface using suitable tool.
  - Remove the liquid gasket completely from the groove of the liquid gasket application surface, bolts, and bolt holes.
2. Thoroughly clean the mating surfaces and remove adhering moisture, grease and foreign material.

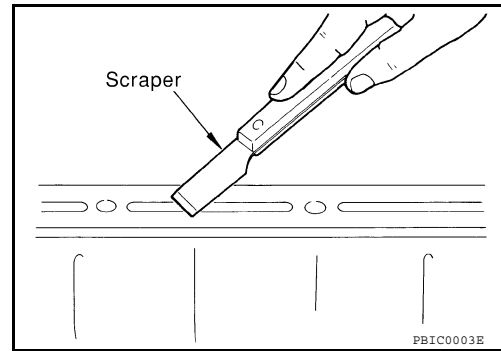

3. Attach the liquid gasket tube to the Tool.

**Tool number : WS39930000 ( — )**

**Use Genuine RTV Silicone Sealant or equivalent. Refer to [GI-14, "Recommended Chemical Products and Sealants"](#).**

4. Apply the liquid gasket without breaks to the specified location with the specified dimensions.

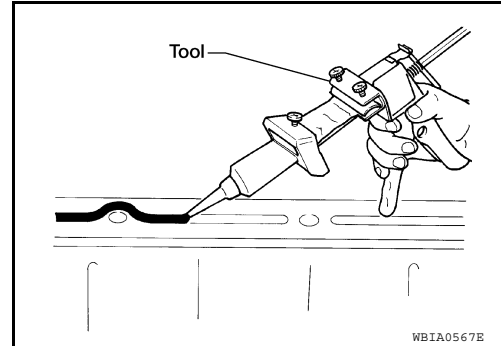

- If there is a groove for the liquid gasket application, apply the liquid gasket to the groove.
- As for the bolt holes, normally apply the liquid gasket inside the holes. If specified in the procedure, it should also be applied outside the holes.
- Within five minutes of liquid gasket application, install the mating component.
- If the liquid gasket protrudes, wipe it off immediately.
- Do not retighten after the installation.
- Wait 30 minutes or more after installation before refilling the engine with engine oil and engine coolant.

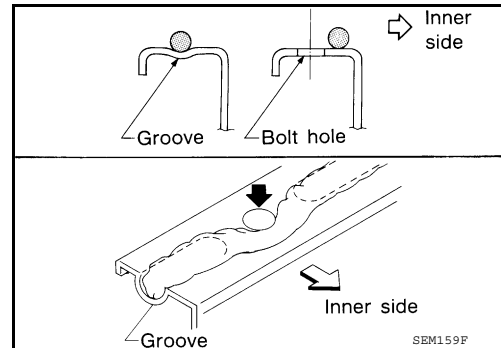

### **CAUTION:**

**If there are specific instructions in this manual, observe them.**

# PREPARATION

< PREPARATION >

[VQ40DE]

## PREPARATION

### PREPARATION

#### Special Service Tool

INFOID:000000005281591

The actual shapes of Kent-Moore tools may differ from those of special service tools illustrated here.

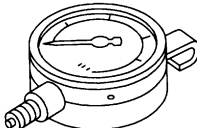
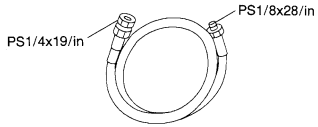
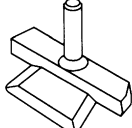
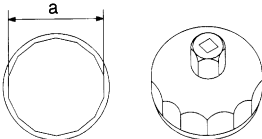
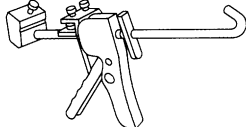
Tool number (Kent-Moore No.) Tool name	Description
ST25051001 (J-25695-1) Oil pressure gauge   S-NT050	Measuring oil pressure <b>Maximum measuring range:</b> <b>2,452 kPa (25 kg/cm<sup>2</sup>, 356 psi)</b>
ST25052000 (J-25695-2) Hose   S-NT559	Adapting oil pressure gauge to cylinder block
KV10111100 (J-37228) Seal cutter   NT046	Removing steel oil pan and rear timing chain case
KV10115801 (J-38956) Oil filter wrench   S-NT375	Removing and installing oil filter <b>a: 64.3 mm (2.531 in)</b>
WS39930000 ( — ) Tube presser   S-NT052	Pressing the tube of liquid gasket

#### Commercial Service Tool

INFOID:000000005281592

# PREPARATION

< PREPARATION >

[VQ40DE]

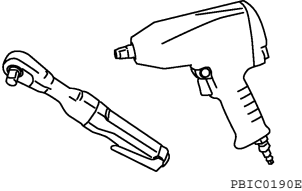
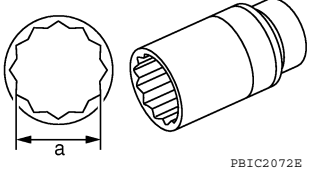
Tool name	Description
<p>Power tool</p>  <p>PBIC0190E</p>	<p>Loosening nuts and bolts</p>
<p>Deep socket</p>  <p>PBIC2072E</p>	<p>Removing and installing oil pressure switch  <b>a: 24 mm (0.94 in)</b></p>

A

LU

C

D

E

F

G

H

I

J

K

L

M

N

O

P

# LUBRICATION SYSTEM

< FUNCTION DIAGNOSIS >

[VQ40DE]

## FUNCTION DIAGNOSIS

### LUBRICATION SYSTEM

#### Lubrication Circuit

INFOID:000000005281593

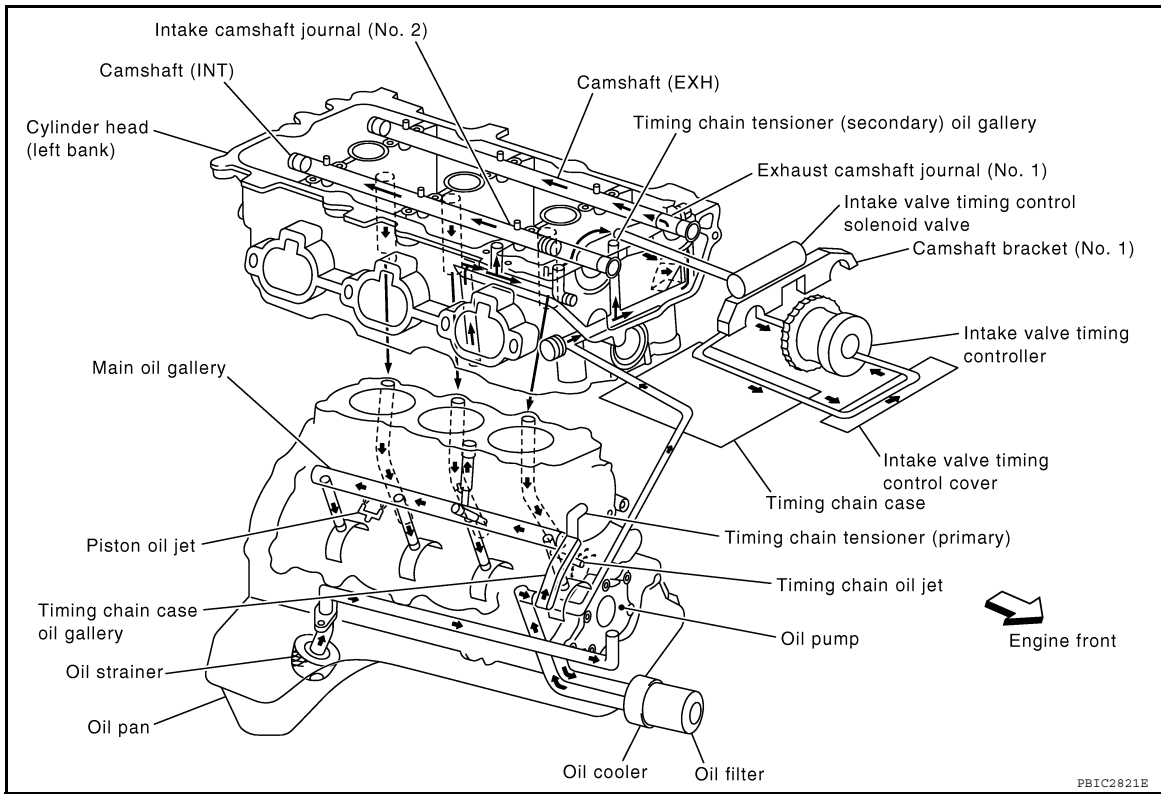

PBIC2821E

#### System Chart

INFOID:000000005281594

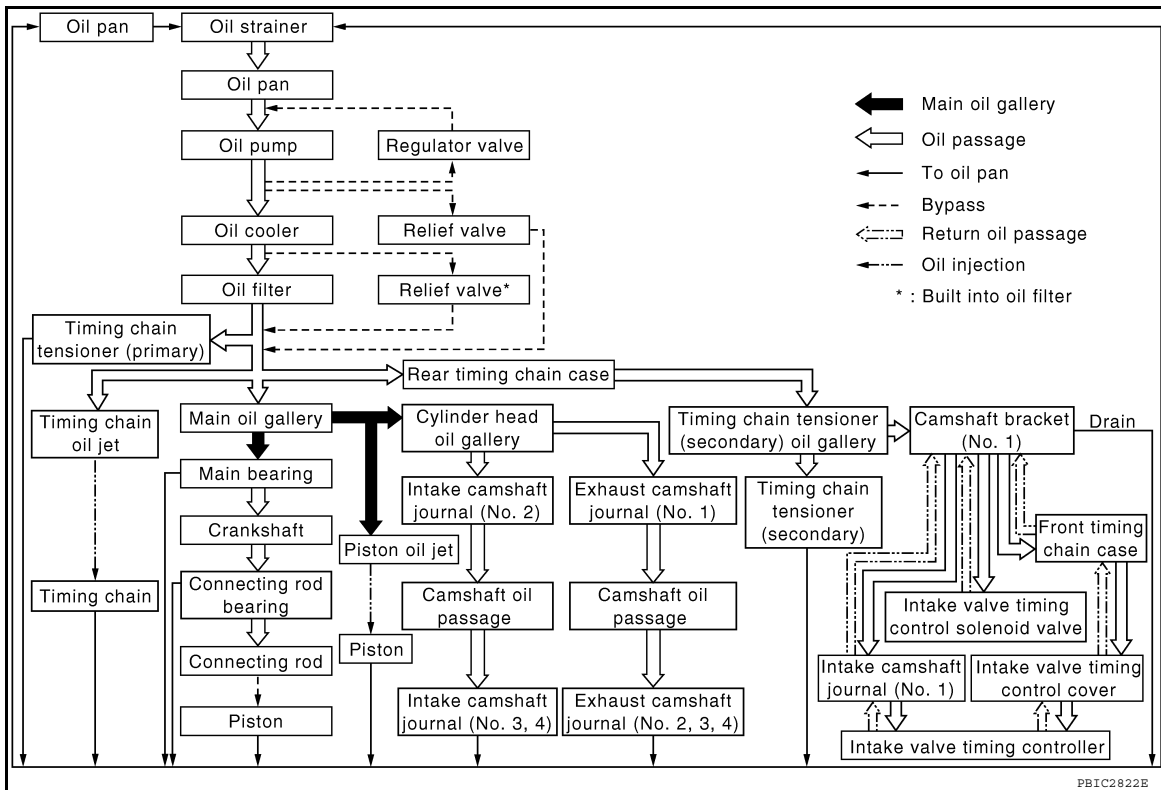

PBIC2822E

# ON-VEHICLE MAINTENANCE

## ENGINE OIL

### Inspection

INFOID:000000005281595

LU

#### OIL LEVEL

- Before starting the engine make sure the vehicle is parked on a flat and level surface, then check the oil level. If the engine is already running, turn it off and allow 10 minutes before checking.
- Pull out oil level gauge and wipe clean.
- Insert oil level gauge.
- Check that the oil level is within the low (L) and high (H) range as indicated on the dipstick.
- If the engine oil level is out of range, add oil as necessary. Refer to [MA-10, "Fluids and Lubricants"](#).

#### CAUTION:

**Do not overfill the engine with oil.**

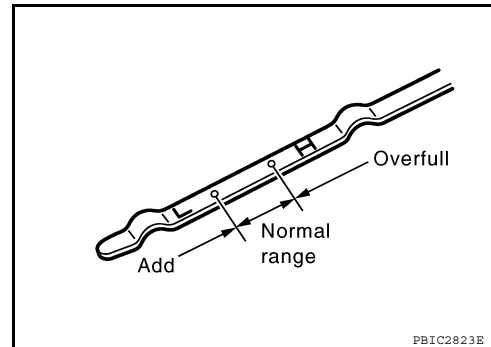

#### OIL APPEARANCE

- Check the engine oil for a white milky appearance or excessive contamination.
- If the engine oil is milky, it is highly probable that it is contaminated with engine coolant. Repair or replace damaged parts.

#### OIL LEAKAGE

Check for oil leakage around the following areas:

- Oil pans (lower and upper)
- Oil pan drain plug
- Oil pressure switch
- Oil filter
- Oil cooler
- Water pump cover
- Chain tensioner cover
- Intake valve timing control cover and intake valve timing control solenoid valve
- Mating surface between cylinder block and cylinder head
- Mating surface between lower cylinder block and cylinder block
- Mating surface between cylinder head and rocker cover
- Mating surface between front timing chain case and rear timing chain case
- Mating surface between rear timing chain case and cylinder head
- Mating surface between rear timing chain case and cylinder block
- Mating surface between rear timing chain case and lower cylinder block
- Mating surface between rear timing chain case and oil pan (upper)
- Crankshaft oil seals (front and rear)
- Oil level gauge guide
- Camshaft position sensor (PHASE)

#### OIL PRESSURE CHECK

#### WARNING:

- **Be careful not to burn yourself, as the engine and engine oil may be hot.**
- **Put the A/T shift selector in the Park (P) position (A/T models) or Neutral position (M/T models), and apply parking brake securely.**

1. Check engine oil level. Refer to [LU-7, "Inspection"](#).
2. Remove engine under cover. Refer to [EXT-13, "Removal and Installation"](#).

# ENGINE OIL

[VQ40DE]

## < ON-VEHICLE MAINTENANCE >

3. Disconnect the oil pressure switch (B) harness connector.
  - A: Oil pan (upper)
  - ⇐: Front
4. Remove the oil pressure switch (B).

**CAUTION:**

**Do not drop or shock oil pressure switch.**

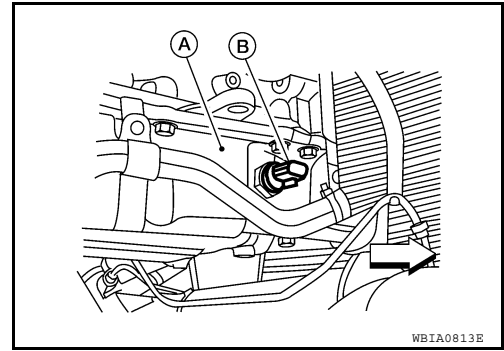

5. Install Tools.

**Tool numbers : ST25051001 (J-25695-1)**

**: ST25052000 (J-25695-2)**

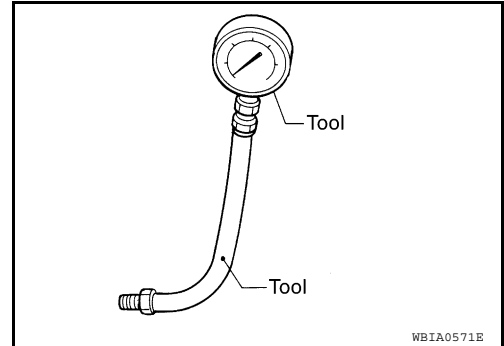

6. Start the engine and warm it up to normal operating temperature.
7. Check the engine oil pressure with engine running under no-load. Refer to [LU-16, "Standard and Limit"](#).

**CAUTION:**

**If the difference is extreme, check the oil passages and oil pump for leaks and blockages.**

8. After the inspections, install oil pressure switch as follows:
  - a. Remove old liquid gasket adhering to oil pressure switch and engine.
  - b. Apply liquid gasket and tighten oil pressure switch to the specification.

**Use Genuine RTV Silicone Sealant or equivalent. Refer to [GI-14, "Recommended Chemical Products and Sealants"](#).**

**Oil pressure switch torque : 14.7 N·m (1.5 kg·m, 11 ft·lb)**

- c. After warming up engine, make sure there is no leakage of engine oil with running engine.

## Changing Engine Oil

INFOID:000000005281596

**WARNING:**

- Be careful not to burn yourself, as the engine and engine oil may be hot.
- Prolonged and repeated contact with used engine oil may cause skin cancer; try to avoid direct skin contact with used oil. If skin contact is made, wash thoroughly with soap or hand cleaner as soon as possible.

1. Warm up the engine, and check for any oil leaks.
2. Stop the engine and wait for at least 10 minutes.
3. Remove the oil drain plug and oil filler cap to drain the old oil.
4. Install a new washer on the oil drain plug, then install the oil drain plug in the oil pan.

**CAUTION:**

**Clean the drain plug and install with a new washer.**

**Oil drain plug : Refer to [EM-34, "Exploded View"](#).**

5. Refill the engine with new specified engine oil.

**Oil grade and viscosity : Refer to [MA-10, "Fluids and Lubricants"](#).**

**Oil capacity : Refer to [MA-10, "Fluids and Lubricants"](#).**



# ENGINE OIL

< ON-VEHICLE MAINTENANCE >

[VQ40DE]

**CAUTION:**

The refill capacity depends on the oil temperature and drain time. Use the "Refill oil capacity" values as a reference and check the oil level using the dipstick when filling the engine with oil.

6. Warm up the engine and check the area around the drain plug and oil filter for any oil leaks.
7. Stop the engine and wait for more than 10 minutes.
8. Check the oil level using the dipstick as shown. Add oil as necessary and install the oil filler cap. Refer to [LU-7, "Inspection"](#).

**CAUTION:**

Do not overfill the engine with oil.

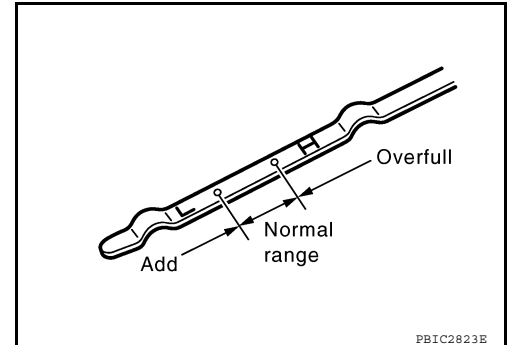

A

LU

C

D

E

F

G

H

I

J

K

L

M

N

O

P

## OIL FILTER

### Removal and Installation

INFOID:000000005281597

#### REMOVAL

1. Remove the engine under cover. Refer to [EXT-13, "Removal and Installation"](#).
2. Drain engine oil. Refer to [LU-8, "Changing Engine Oil"](#).
3. Remove the oil filter using Tool as shown.

**Tool number** : KV10115801 (J-38956)

**WARNING:**

Be careful not to burn yourself, as the engine and engine oil may be hot.

**CAUTION:**

- Oil filter is equipped with a pressure relief valve.
- Use Genuine NISSAN Oil Filter or equivalent.
- When removing, prepare a shop cloth to absorb any engine oil leaks or spills.
- Do not allow engine oil to adhere to drive belts.
- Completely wipe off any engine oil that adheres to the engine and the vehicle.

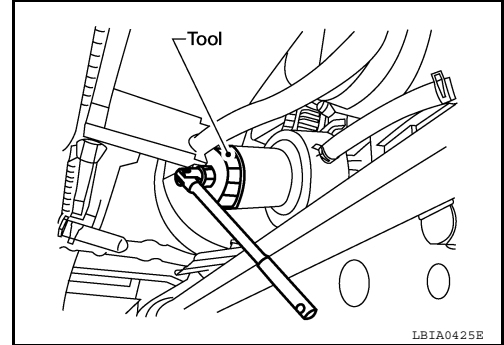

#### INSTALLATION

1. Remove foreign materials adhering to the oil filter seal mating surface.
2. Apply clean engine oil to the oil filter seal circumference of the new oil filter as shown.

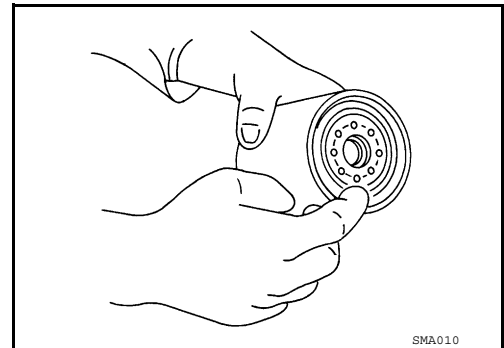

3. Screw on the oil filter manually until it touches the installation surface, then tighten it by 2/3 turn as shown. Or tighten to specification.

**Oil filter** : 17.7 N·m (1.8 kg·m, 13 ft·lb)

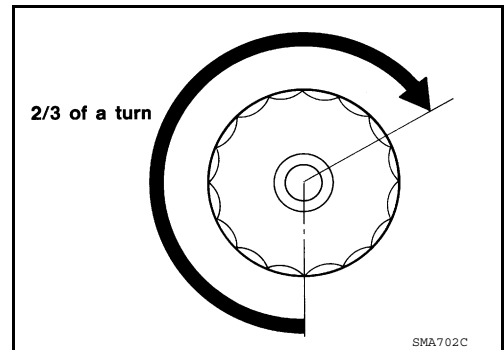

4. Refill engine with new engine oil. Refer to [LU-8, "Changing Engine Oil"](#).
5. Inspect the engine for oil leaks. Refer to [LU-7, "Inspection"](#).
6. Install the engine under cover. Refer to [EXT-13, "Removal and Installation"](#).

#### INSPECTION AFTER INSTALLATION

1. Check the engine oil level. Refer to [LU-7, "Inspection"](#).
2. Start the engine and check for engine oil leaks.
3. Stop the engine and wait for 10 minutes.
4. Check the engine oil level and add engine oil level as required.

ON-VEHICLE REPAIR

OIL COOLER

Exploded View

INFOID:000000005281598

A

LU

C

D

E

F

G

H

I

J

K

L

M

N

O

P

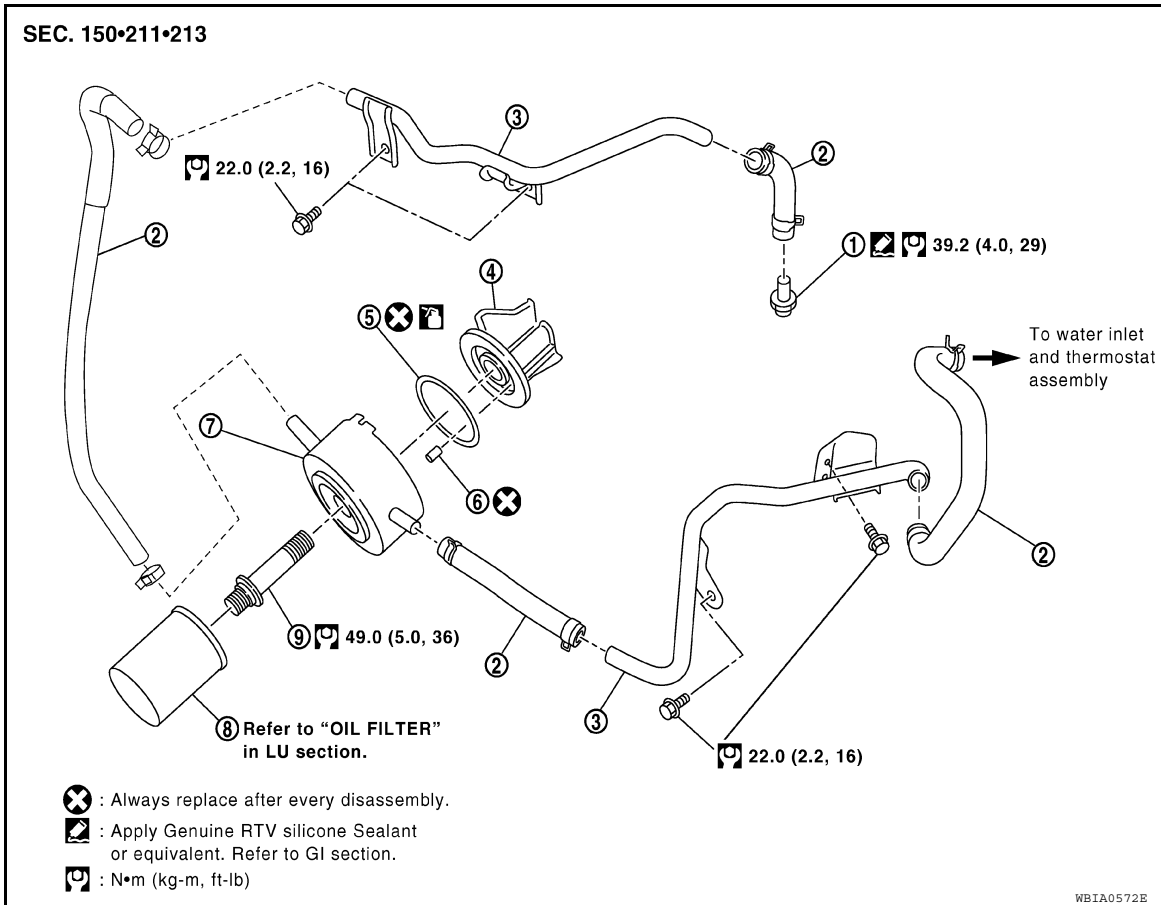

- |                               |               |                   |
|-------------------------------|---------------|-------------------|
| 1. Water connector            | 2. Water hose | 3. Water pipe     |
| 4. Oil pan (upper) front side | 5. O-ring     | 6. Relief valve   |
| 7. Oil cooler                 | 8. Oil filter | 9. Connector bolt |

Removal and Installation

INFOID:000000005281599

**WARNING:**

Be careful not to burn yourself, as the engine oil and engine coolant may be hot.

**CAUTION:**

- Do not spill engine coolant on the drive belt.
- Do not spill engine oil on rubber parts such as drive belts and engine mounting insulator.

REMOVAL

**NOTE:**

When removing oil cooler only, step 1 is unnecessary.

1. Drain engine coolant from radiator and cylinder block. Refer to [CO-11. "Changing Engine Coolant"](#) and [EM-100. "Disassembly and Assembly"](#).

**NOTE:**

Perform this step only when removing water pipes and hoses.

2. Remove engine under cover. Refer to [EXT-13. "Removal and Installation"](#).
3. Disconnect water hoses from oil cooler, pinching hoses near oil cooler to prevent engine coolant from spilling.

**CAUTION:**

**Perform this step when engine is cold.**

4. Remove oil filter. Refer to [LU-10, "Removal and Installation"](#).
5. Remove connector bolt, and remove oil cooler.

## INSPECTION AFTER REMOVAL

## Oil Cooler

Check oil cooler for cracks. Check oil cooler for clogging by blowing compressed air through engine coolant inlet. If necessary, replace oil cooler assembly.

## Relief Valve

Check relief valve for movement, cracks and breaks by pushing the ball. If replacement is necessary, remove relief valve by prying it out using a suitable tool. Install a new relief valve in place by tapping it in.

## INSTALLATION

Installation is in the reverse order of removal, paying attention to the following.

- Confirm that no foreign objects are adhering to the sealing surfaces of the oil cooler and oil pan (upper).
- Tighten connector bolt after aligning cutout on oil cooler with protrusion on oil pan (upper) side.

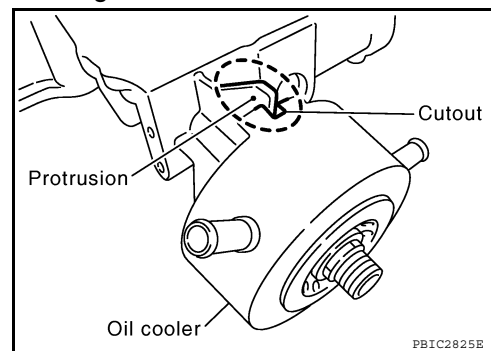

## INSPECTION AFTER INSTALLATION

1. Check engine oil and engine coolant levels and add engine oil and engine coolant. Refer to [LU-7, "Inspection"](#) and [CO-10, "System Inspection"](#).
2. Start the engine, and check for leaks of engine oil or engine coolant.
3. Stop engine and wait for 10 minutes.
4. Check the engine oil level and the engine coolant level again. Refer to [LU-7, "Inspection"](#) and [CO-10, "System Inspection"](#).

# OIL PUMP

< ON-VEHICLE REPAIR >

[VQ40DE]

## OIL PUMP

### Exploded View

INFOID:000000005281600

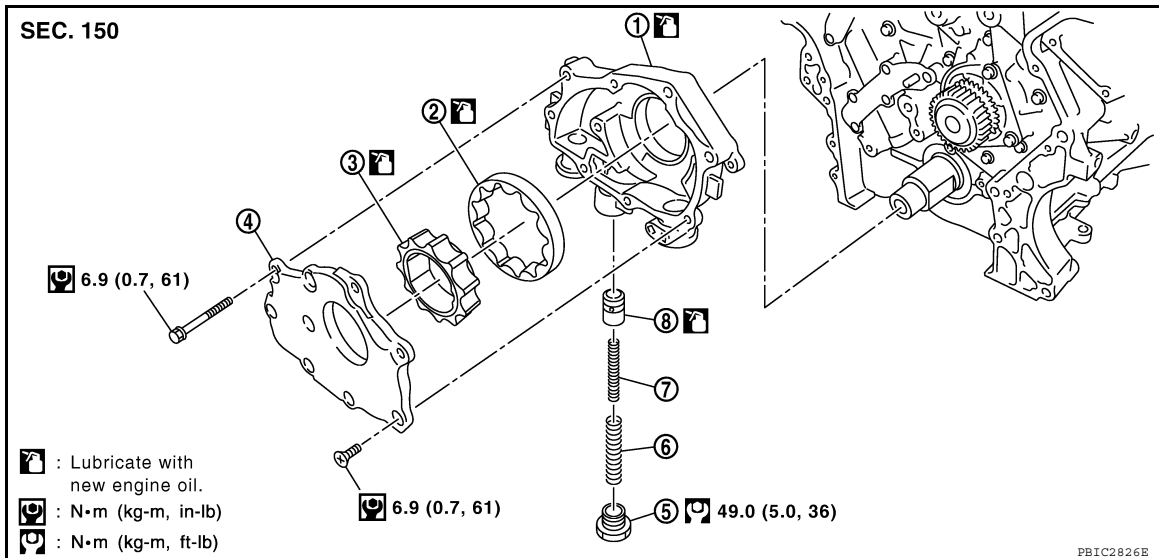

- |                           |                         |                           |
|---------------------------|-------------------------|---------------------------|
| 1. Oil pump body          | 2. Oil pump outer rotor | 3. Oil pump inner rotor   |
| 4. Oil pump cover         | 5. Regulator valve plug | 6. Regulator valve spring |
| 7. Regulator valve spring | 8. Regulator valve      |                           |

### Removal and Installation

INFOID:000000005281601

#### REMOVAL

1. Disconnect the battery negative terminal. Refer to [PG-71, "Removal and Installation"](#).
2. Remove the RH and LH front wheels and tires. Refer to [WT-45, "Adjustment"](#).
3. Remove the RH and LH front fender protectors. Refer to [EXT-18, "Removal and Installation"](#).
4. Remove the air duct and resonator assembly and the air cleaner case (upper). Refer to [EM-24, "Exploded View"](#).
5. Remove timing chain (primary) only. Refer to [EM-58, "Removal and Installation"](#).
6. Remove the oil pump assembly.

#### INSTALLATION

Installation is in the reverse order of removal, paying attention to the following.

- When installing, align crankshaft flat faces with inner rotor flat faces.

#### INSPECTION AFTER INSTALLATION

1. Check the engine oil level. Refer to [LU-7, "Inspection"](#).
2. Start the engine and check for engine oil leaks.
3. Stop engine and wait for 10 minutes.
4. Check the engine oil level and adjust engine oil level as required. Refer to [LU-7, "Inspection"](#).

## DISASSEMBLY AND ASSEMBLY

### OIL PUMP

#### Disassembly and Assembly

INFOID:000000005281602

#### DISASSEMBLY

1. Remove oil pump cover.
2. Remove inner rotor and outer rotor from oil pump body.
3. Remove the regulator valve plug, regulator valve spring and regulator valve.

#### INSPECTION AFTER DISASSEMBLY

##### Clearance of Oil Pump Parts

- Measure radial clearance using a suitable tool.

**Body to outer rotor (position 1)**  
: 0.120 - 0.195 mm (0.0047 - 0.0077 in)

**Inner rotor to outer rotor tip (position 2)**  
: 0.060 - 0.160 mm (0.0024 - 0.0063 in)

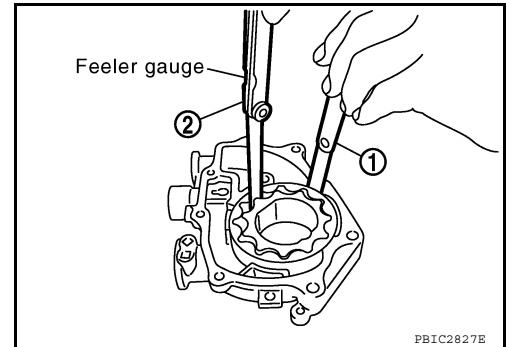

- Measure side clearance using suitable tools.

**Body to inner rotor (position 3)**  
: 0.030 - 0.070 mm (0.0012 - 0.0028 in)

**Body to outer rotor (position 4)**  
: 0.050 - 0.090 mm (0.0020 - 0.0035 in)

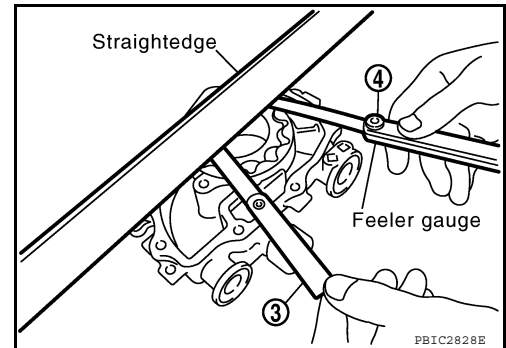

- Calculate the clearance between inner rotor and oil pump body as follows.

1. Measure the inner diameter of oil pump body to brazed portion (position 5) using suitable tool.
2. Measure the outer diameter of protruded portion of inner rotor (position 6) using suitable tool.

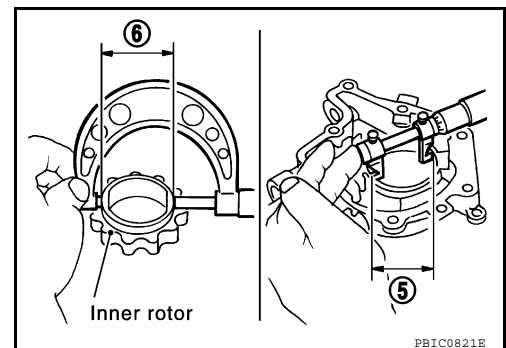

3. Calculate the clearance using the following formula.
  - (Clearance) = (Inner diameter of oil pump body) - (Outer diameter of inner rotor)

**Inner rotor to brazed portion of housing clearance**  
: 0.045 - 0.091 mm (0.0018 - 0.0036 in)

#### Regulator Valve Clearance

# OIL PUMP

[VQ40DE]

## < DISASSEMBLY AND ASSEMBLY >

Check regulator valve to oil pump cover clearance using the following formula.

- (Clearance) = D1 (Valve hole diameter) - D2 (Outer Diameter of valve)

**Regulator valve to oil pump cover**  
**: 0.025 - 0.070 mm (0.0010 - 0.0028 in)**

### CAUTION:

- Coat regulator valve with engine oil.
- Check that it falls smoothly into the regulator valve hole by its own weight.

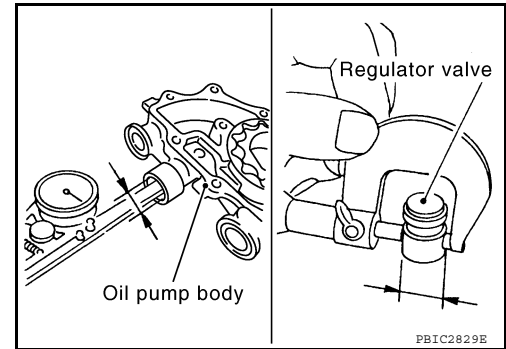

## ASSEMBLY

Installation is in the reverse order of removal.

### NOTE:

Install oil pump inner rotor with the groove faced and oil pump outer rotor with the punch mark to oil pump cover side.

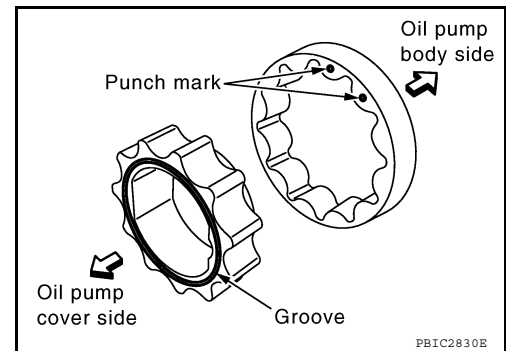

# SERVICE DATA AND SPECIFICATIONS (SDS)

< SERVICE DATA AND SPECIFICATIONS (SDS)

[VQ40DE]

## SERVICE DATA AND SPECIFICATIONS (SDS)

### SERVICE DATA AND SPECIFICATIONS (SDS)

#### Standard and Limit

INFOID:000000005281603

#### OIL PRESSURE

Unit: kPa (kg/cm<sup>2</sup>, psi)

Engine speed	Approximate discharge oil pressure*
Idle speed	More than 98 (1.0, 14)
2,000 rpm	More than 294 (3.0, 43)

\*: Engine oil temperature at 80°C (176°F)

#### OIL PUMP

Unit: mm (in)

Body to outer rotor	0.120 - 0.195 (0.0047 - 0.0077)
Inner rotor to outer rotor tip	0.060 - 0.160 (0.0024 - 0.0063)
Body to inner rotor	0.030 - 0.070 (0.0012 - 0.0028)
Body to outer rotor	0.050 - 0.090 (0.0020 - 0.0035)
Inner rotor to brazed portion of housing	0.045 - 0.091 (0.0018 - 0.0036)

#### REGULATOR VALVE

Unit: mm (in)

Regulator valve to oil pump cover	0.025 - 0.070 (0.0010 - 0.0028)
-----------------------------------	---------------------------------

#### ENGINE OIL CAPACITY (APPROXIMATE)

Unit: ℓ (US qt, Imp qt)

Drain and refill	With oil filter change	5.1 (5-3/8, 4-1/2)
	Without oil filter change	4.8 (5-1/8, 4-1/4)
Dry engine (Overhaul)		6.3 (6-5/8, 5-1/2)