

MWI

SECTION

METER, WARNING LAMP & INDICATOR

A
B
C
D
E
F
G
H
I
J
K
L
M
O
P

CONTENTS

| | | | |
|---|----|---|----|
| BASIC INSPECTION | 3 | FUEL GAUGE : Component Description | 12 |
| DIAGNOSIS AND REPAIR WORKFLOW | 3 | ENGINE OIL PRESSURE GAUGE | 12 |
| Work Flow | 3 | ENGINE OIL PRESSURE GAUGE : System Dia- | 12 |
| FUNCTION DIAGNOSIS | 4 | gram | 12 |
| METER SYSTEM | 4 | ENGINE OIL PRESSURE GAUGE : System De- | 12 |
| METER SYSTEM | 4 | scription | 12 |
| METER SYSTEM : System Diagram | 4 | ENGINE OIL PRESSURE GAUGE : Component | 12 |
| METER SYSTEM : System Description | 4 | Parts Location | 12 |
| METER SYSTEM : Arrangement of Combination | | ENGINE OIL PRESSURE GAUGE : Component | 13 |
| Meter | 5 | Description | 13 |
| METER SYSTEM : Component Parts Location | 6 | VOLTAGE GAUGE | 13 |
| METER SYSTEM : Component Description | 6 | VOLTAGE GAUGE : System Diagram | 13 |
| SPEEDOMETER | 7 | VOLTAGE GAUGE : System Description | 13 |
| SPEEDOMETER : System Diagram | 7 | VOLTAGE GAUGE : Component Parts Location | 14 |
| SPEEDOMETER : System Description | 7 | VOLTAGE GAUGE : Component Description | 14 |
| SPEEDOMETER : Component Parts Location | 7 | ODO/TRIP METER | 14 |
| SPEEDOMETER : Component Description | 8 | ODO/TRIP METER : System Diagram | 14 |
| TACHOMETER | 8 | ODO/TRIP METER : System Description | 15 |
| TACHOMETER : System Diagram | 8 | ODO/TRIP METER : Component Parts Location | 15 |
| TACHOMETER : System Description | 8 | ODO/TRIP METER : Component Description | 15 |
| TACHOMETER : Component Parts Location | 9 | SHIFT POSITION INDICATOR | 15 |
| TACHOMETER : Component Description | 9 | SHIFT POSITION INDICATOR : System Diagram | 16 |
| ENGINE COOLANT TEMPERATURE GAUGE | 9 | SHIFT POSITION INDICATOR : System Descrip- | 16 |
| ENGINE COOLANT TEMPERATURE GAUGE : | | tion | 16 |
| System Diagram | 9 | SHIFT POSITION INDICATOR : Component | 16 |
| ENGINE COOLANT TEMPERATURE GAUGE : | | Parts Location | 16 |
| System Description | 10 | SHIFT POSITION INDICATOR : Component De- | 17 |
| ENGINE COOLANT TEMPERATURE GAUGE : | | scription | 17 |
| Component Parts Location | 10 | WARNING LAMPS/INDICATOR LAMPS | 17 |
| ENGINE COOLANT TEMPERATURE GAUGE : | | WARNING LAMPS/INDICATOR LAMPS : System | 17 |
| Component Description | 10 | Diagram | 17 |
| FUEL GAUGE | 10 | WARNING LAMPS/INDICATOR LAMPS : System | 17 |
| FUEL GAUGE : System Diagram | 11 | Description | 17 |
| FUEL GAUGE : System Description | 11 | WARNING LAMPS/INDICATOR LAMPS : Com- | 17 |
| FUEL GAUGE : Component Parts Location | 11 | ponent Parts Location | 17 |
| | | WARNING LAMPS/INDICATOR LAMPS : Com- | 18 |
| | | ponent Description | 18 |

MWI

| | | | |
|--|-----------|--|-----------|
| TRIP COMPUTER | 18 | DTC Index | 53 |
| TRIP COMPUTER : System Diagram | 18 | BCM (BODY CONTROL MODULE) | 54 |
| TRIP COMPUTER : System Description | 18 | Reference Value | 54 |
| TRIP COMPUTER : Component Parts Location ... | 19 | Terminal Layout | 57 |
| TRIP COMPUTER : Component Description | 19 | Physical Values | 57 |
| DIAGNOSIS SYSTEM (METER) | 21 | Wiring Diagram | 63 |
| Diagnosis Description | 21 | Fail Safe | 66 |
| CONSULT-III Function (METER/M&A) | 22 | DTC Inspection Priority Chart | 67 |
| COMPONENT DIAGNOSIS | 25 | DTC Index | 67 |
| DTC U1000 CAN COMMUNICATION | 25 | IPDM E/R (INTELLIGENT POWER DISTRI- BUTION MODULE ENGINE ROOM) | 69 |
| DTC Logic | 25 | Reference Value | 69 |
| Diagnosis Procedure | 25 | Terminal Layout | 70 |
| DTC B2205 VEHICLE SPEED CIRCUIT | 26 | Physical Values | 71 |
| Description | 26 | Wiring Diagram | 75 |
| DTC Logic | 26 | Fail Safe | 78 |
| Diagnosis Procedure | 26 | DTC Index | 80 |
| POWER SUPPLY AND GROUND CIRCUIT | 27 | SYMPTOM DIAGNOSIS | 81 |
| COMBINATION METER | 27 | THE FUEL GAUGE POINTER DOES NOT MOVE | 81 |
| COMBINATION METER : Diagnosis Procedure ... | 27 | Description | 81 |
| BCM (BODY CONTROL MODULE) | 27 | Diagnosis Procedure | 81 |
| BCM (BODY CONTROL MODULE) : Diagnosis Procedure | 28 | THE FUEL GAUGE POINTER DOES NOT MOVE TO "F" WHEN REFUELING | 82 |
| IPDM E/R (INTELLIGENT POWER DISTRI- BUTION MODULE ENGINE ROOM) | 28 | Description | 82 |
| IPDM E/R (INTELLIGENT POWER DISTRI- BUTION MODULE ENGINE ROOM) : Diagnosis Pro- cedure | 29 | Diagnosis Procedure | 82 |
| FUEL LEVEL SENSOR SIGNAL CIRCUIT | 30 | THE OIL PRESSURE WARNING LAMP DOES NOT TURN ON | 83 |
| Description | 30 | Description | 83 |
| Component Function Check | 30 | Diagnosis Procedure | 83 |
| Diagnosis Procedure | 30 | THE OIL PRESSURE WARNING LAMP DOES NOT TURN OFF | 84 |
| Component Inspection | 31 | Description | 84 |
| OIL PRESSURE SWITCH SIGNAL CIRCUIT ... | 33 | Diagnosis Procedure | 84 |
| Description | 33 | PRECAUTION | 85 |
| Component Function Check | 33 | PRECAUTIONS | 85 |
| Diagnosis Procedure | 33 | Precaution for Supplemental Restraint System (SRS) "AIR BAG" and "SEAT BELT PRE-TEN- SIONER" | 85 |
| Component Inspection | 33 | ON-VEHICLE REPAIR | 86 |
| ECU DIAGNOSIS | 34 | COMBINATION METER | 86 |
| COMBINATION METER | 34 | Removal and Installation | 86 |
| Reference Value | 34 | | |
| Wiring Diagram | 36 | | |
| Fail Safe | 51 | | |

DIAGNOSIS AND REPAIR WORKFLOW

< BASIC INSPECTION >

BASIC INSPECTION

DIAGNOSIS AND REPAIR WORKFLOW

Work Flow

INFOID:000000005281718

DETAILED FLOW

1.CONFIRM SYMPTOM

Confirm symptom or customer complaint.

>> GO TO 2

2.CHECK SELF-DIAGNOSIS OPERATION OF COMBINATION METER

Perform self-diagnosis of combination meter. Refer to [MWI-21, "Diagnosis Description"](#).

Does self-diagnosis mode operate?

YES >> GO TO 3

NO >> Check power supply and ground circuit of combination meter. Refer to [MWI-27, "COMBINATION METER : Diagnosis Procedure"](#). Then, GO TO 4

3.CHECK COMBINATION METER (CONSULT-III)

Select "METER/M&A" on CONSULT-III and perform "SELF-DIAGNOSIS" of combination meter. Refer to [MWI-22, "CONSULT-III Function \(METER/M&A\)"](#).

Self-diagnostic results content

No malfunction detected>>Repair or replace the cause of symptom. Then, GO TO 4

Malfunction detected>>Refer to [MWI-53, "DTC Index"](#). Then, GO TO 4

4.CONFIRM OPERATION

Does the combination meter operate normally?

YES or NO

YES >> Inspection End.

NO >> GO TO 1

A
B
C
D
E
F
G
H
I
J
K
L
M
O
P

MWI

METER SYSTEM

< FUNCTION DIAGNOSIS >

FUNCTION DIAGNOSIS

METER SYSTEM

METER SYSTEM

METER SYSTEM : System Diagram

INFOID:000000005281719

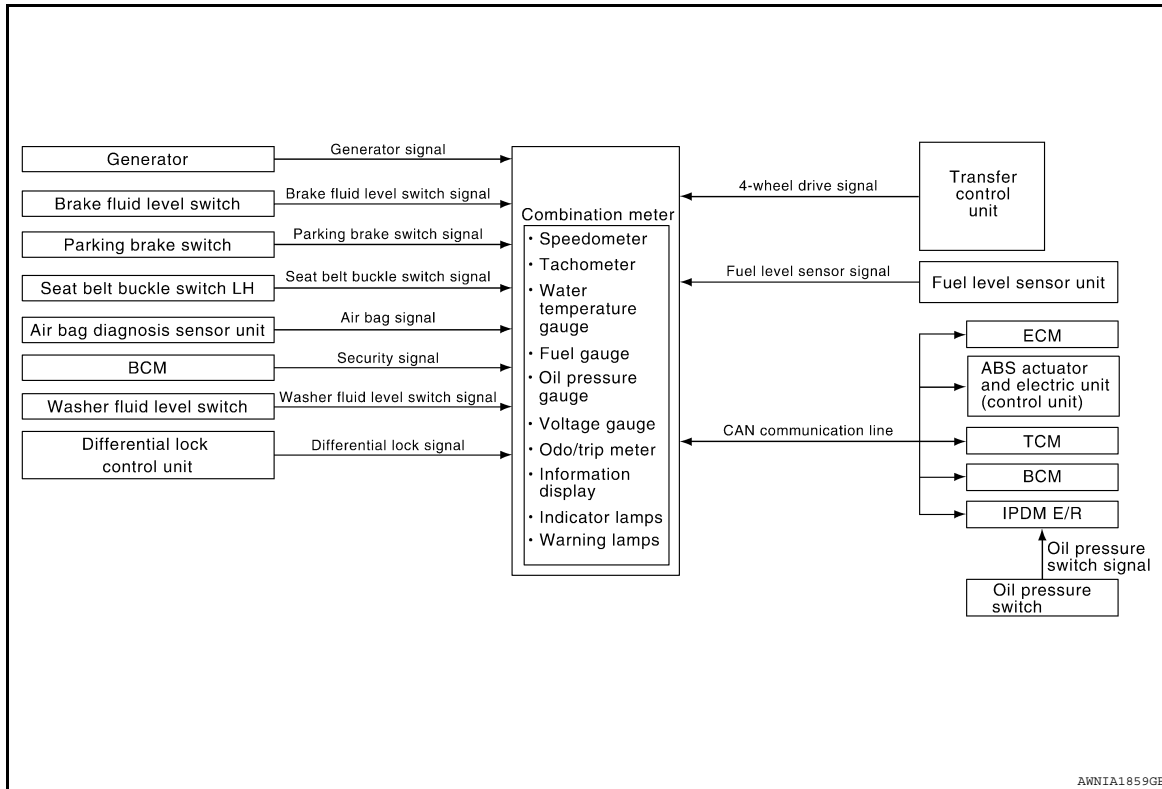

METER SYSTEM : System Description

INFOID:000000005281720

COMBINATION METER

- Speedometer, odo/trip meter, tachometer, fuel gauge, engine coolant temperature gauge, engine oil pressure gauge, voltage gauge and trip computer are controlled by the unified meter control unit, which is built into the combination meter.
- Warning and indicator lamps are controlled by the unified meter control unit and by components connected directly to the combination meter.
- Digital meter is adopted for odo/trip meter*, as well as the A/T position indicator display.
*The record of the odometer is kept even if the battery cable is disconnected. The record of the trip meter is erased when the battery cable is disconnected.
- Odo/trip meter and A/T indicator segments can be checked in diagnosis mode.
- Meter/gauge can be checked in diagnosis mode.

NOTE:

Under the following conditions, the meters will perform a homing function. The meter pointers will move down slightly and then move back to the resting position. This is a normal design condition.

- Approximately 60 seconds after turning the ignition switch from the ON to the OFF position
- If the battery is disconnected and then reconnected

METER SYSTEM

< FUNCTION DIAGNOSIS >

METER SYSTEM : Arrangement of Combination Meter

INFOID:000000005281721

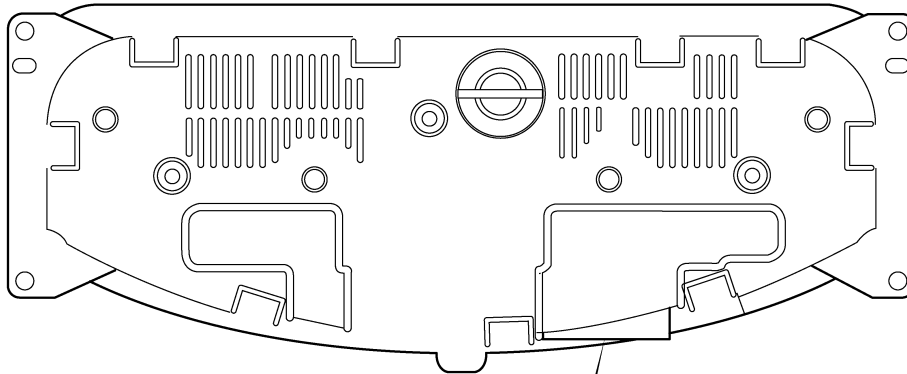
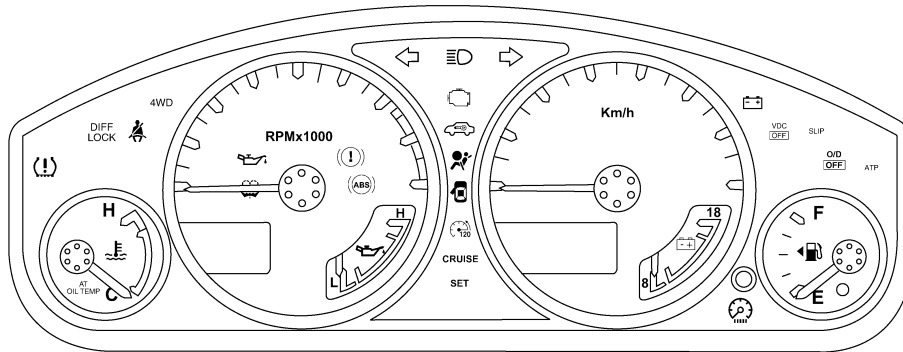

| | | | | | | | | | | | | | | | | | | | | |
|----|----|----|----|----|----|----|----|----|----|----|----|----|----|----|----|----|----|----|----|-------|
| 20 | 19 | 18 | 17 | 16 | 15 | 14 | 13 | 12 | 11 | 10 | 9 | 8 | 7 | 6 | 5 | 4 | 3 | 2 | 1 | (M24) |
| 40 | 39 | 38 | 37 | 36 | 35 | 34 | 33 | 32 | 31 | 30 | 29 | 28 | 27 | 26 | 25 | 24 | 23 | 22 | 21 | |

AWNIA1860GB

A
B
C
D
E
F
G
H
I
J
K
L
M
N
O
P

MWI

METER SYSTEM

< FUNCTION DIAGNOSIS >

METER SYSTEM : Component Parts Location

INFOID:000000005281722

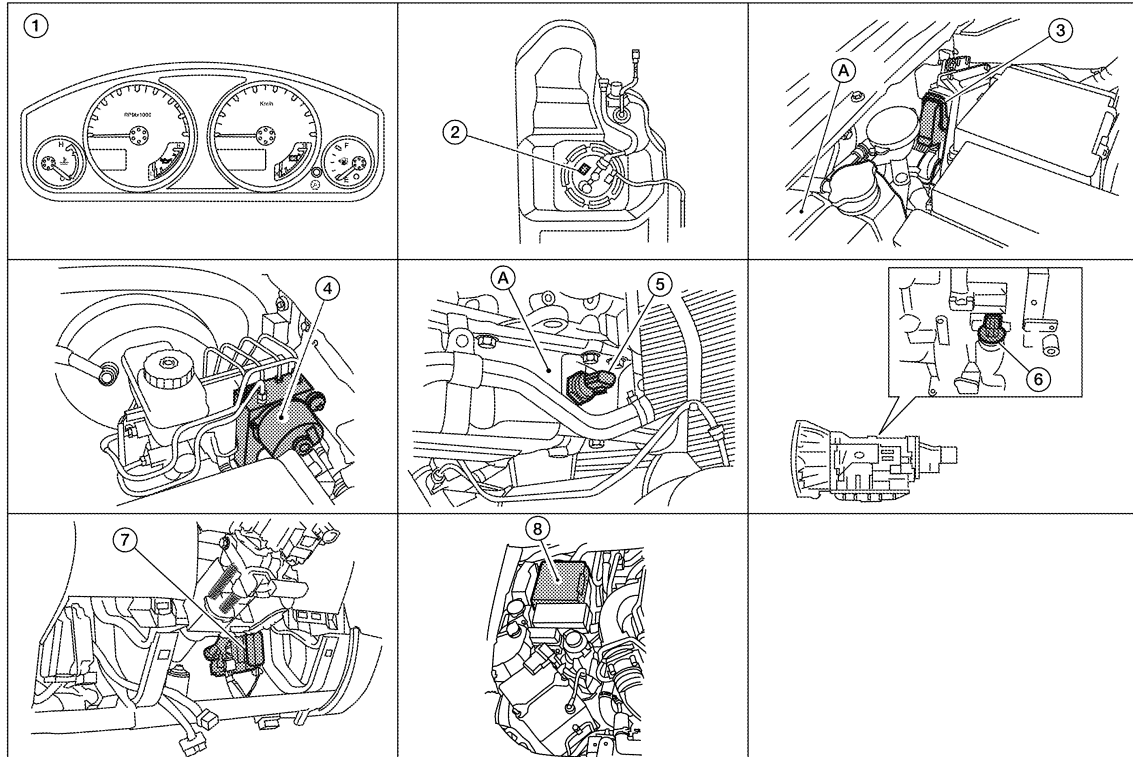

AWNIA10642Z

- | | | |
|---|--|--|
| 1. Combination meter M24 | 2. Fuel level sensor unit and fuel pump C5 (view with fuel tank removed) | 3. ECM E16 (view with ECM cover removed) A. Coolant reservoir |
| 4. ABS actuator and electric unit (control unit) E125 | 5. Oil pressure switch E208 A. Oil pan (upper) | 6. A/T assembly F9 |
| 7. BCM M18, M19 (view with lower instrument panel LH removed) | 8. IPDM E/R E122, E124 | |

METER SYSTEM : Component Description

INFOID:000000005281723

| Unit | Description |
|------------------------|---|
| Combination meter | <p>Controls the following with the signals received from each unit via CAN communication and the signals from switches and sensors.</p> <ul style="list-style-type: none"> • Speedometer • Engine coolant temperature gauge • Engine oil pressure gauge • Voltage gauge • Warning lamps • Trip computer • Tachometer • Fuel gauge • Odo/trip meter • Indicator lamps • Warning chime |
| IPDM E/R | IPDM E/R reads the ON/OFF signals of the oil pressure switch and transmits the oil pressure switch signal to the combination meter via BCM with CAN communication line. |
| Fuel level sensor unit | Refer to MWI-30. "Description" . |
| Oil pressure switch | Refer to MWI-33. "Description" . |
| ECM | <p>Transmits the following signals to the combination meter with CAN communication line.</p> <ul style="list-style-type: none"> • Engine speed signal • Fuel consumption monitor signal • Engine coolant temperature signal |

METER SYSTEM

< FUNCTION DIAGNOSIS >

| Unit | Description |
|---|--|
| ABS actuator and electric unit (control unit) | Transmits the vehicle speed signal to the combination meter with CAN communication line. |
| BCM | <ul style="list-style-type: none"> Transmits signals provided by various units to the combination meter with CAN communication line. Transmits the security signal to the combination meter. |
| TCM | Transmits shift position signal to the combination meter with CAN communication line. |

SPEEDOMETER

SPEEDOMETER : System Diagram

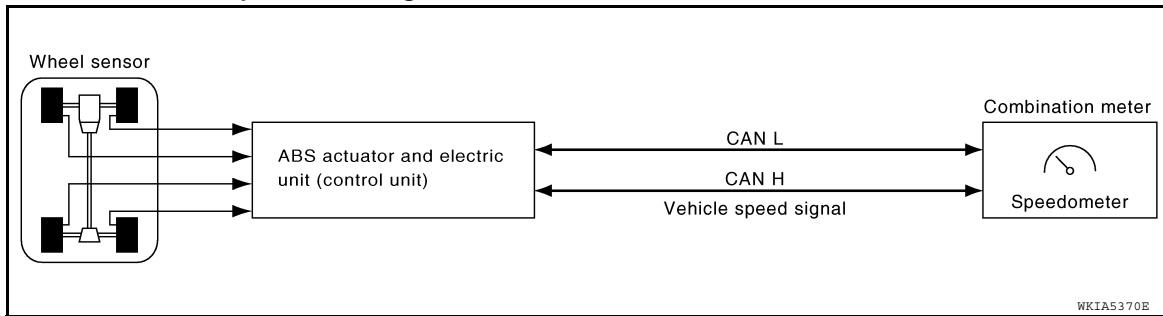

SPEEDOMETER : System Description

INFOID:000000005281725

The ABS actuator and electric unit (control unit) provides a vehicle speed signal to the combination meter via CAN communication lines.

SPEEDOMETER : Component Parts Location

INFOID:000000005730705

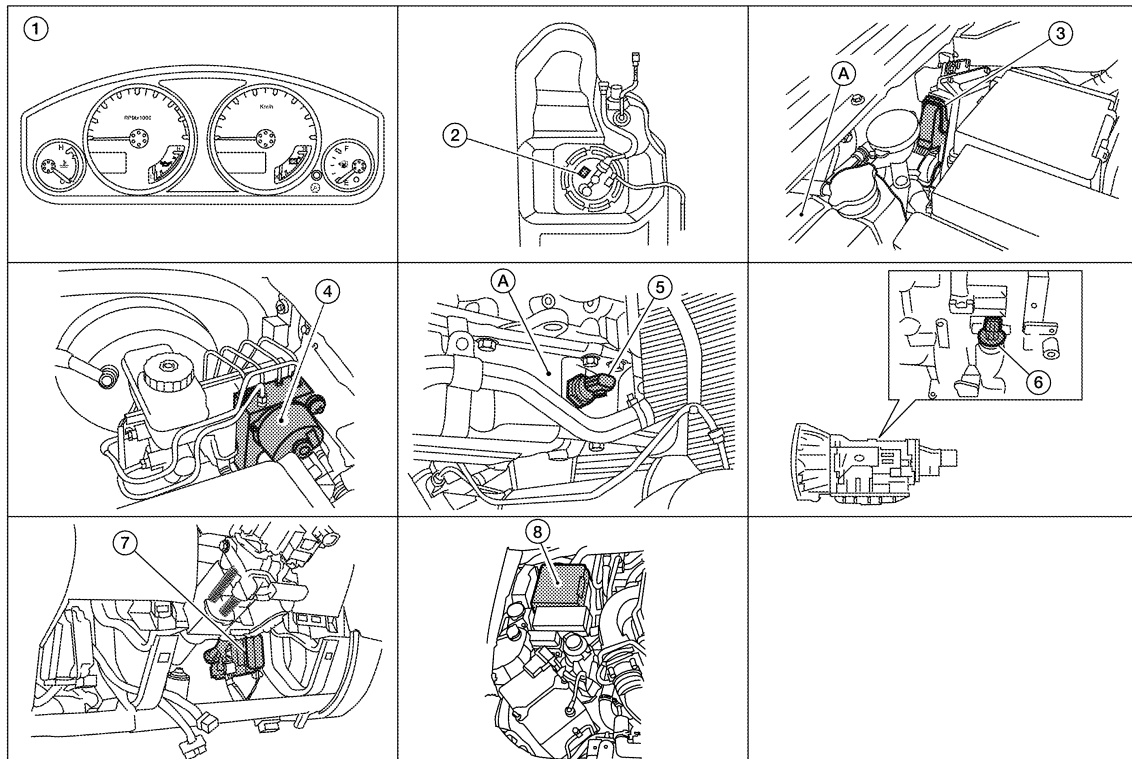

AWNIA1064ZZ

A
B
C
D
E
F
G
H
I
J
K
L
M
N
O
P

MWI

METER SYSTEM

< FUNCTION DIAGNOSIS >

- | | | |
|---|--|--|
| 1. Combination meter M24 | 2. Fuel level sensor unit and fuel pump C5 (view with fuel tank removed) | 3. ECM E16 (view with ECM cover removed) A. Coolant reservoir |
| 4. ABS actuator and electric unit (control unit) E125 | 5. Oil pressure switch E208 A. Oil pan (upper) | 6. A/T assembly F9 |
| 7. BCM M18, M19 (view with lower instrument panel LH removed) | 8. IPDM E/R E122, E124 | |

SPEEDOMETER : Component Description

INFOID:000000005281727

| Unit | Description |
|---|--|
| Combination meter | Indicates the vehicle speed according to the vehicle speed signal received from ABS actuator and electric unit (control unit) via CAN communication. |
| ABS actuator and electric unit (control unit) | Transmits the vehicle speed signal to the combination meter with CAN communication line. |

TACHOMETER

TACHOMETER : System Diagram

INFOID:000000005281728

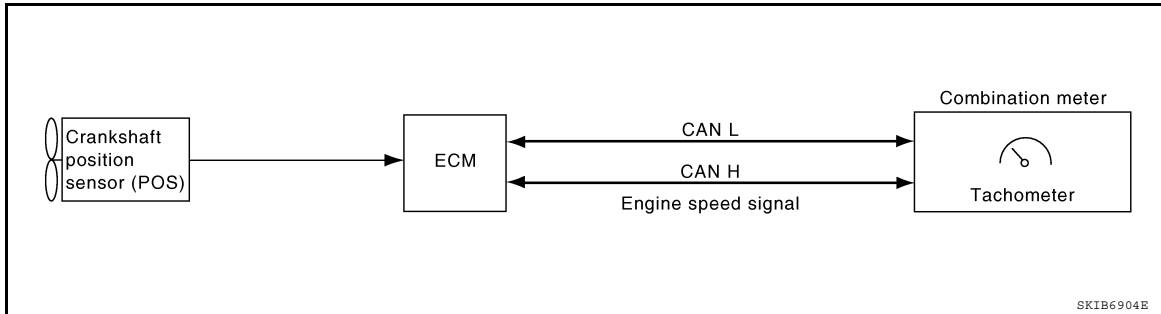

TACHOMETER : System Description

INFOID:000000005281729

The tachometer indicates engine speed in revolutions per minute (rpm).
The ECM provides an engine speed signal to the combination meter via CAN communication lines.

METER SYSTEM

< FUNCTION DIAGNOSIS >

TACHOMETER : Component Parts Location

INFOID:000000005730706

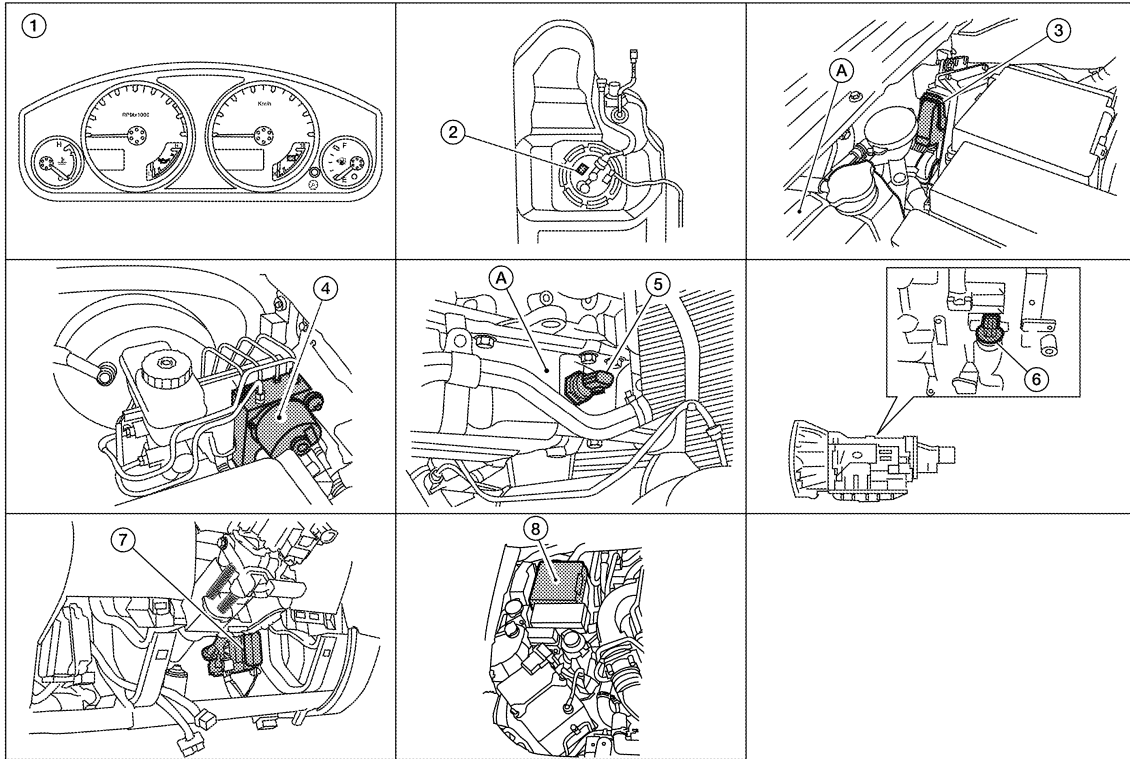

AWNIA1064ZZ

- | | | |
|---|--|--|
| 1. Combination meter M24 | 2. Fuel level sensor unit and fuel pump C5 (view with fuel tank removed) | 3. ECM E16 (view with ECM cover removed) A. Coolant reservoir |
| 4. ABS actuator and electric unit (control unit) E125 | 5. Oil pressure switch E208 A. Oil pan (upper) | 6. A/T assembly F9 |
| 7. BCM M18, M19 (view with lower instrument panel LH removed) | 8. IPDM E/R E122, E124 | |

TACHOMETER : Component Description

INFOID:0000000005281731

| Unit | Description |
|-------------------|---|
| Combination meter | Indicates the engine speed in RPM according to the engine speed signal received from ECM via CAN communication. |
| ECM | Transmits the engine speed signal to the combination meter with CAN communication line. |

ENGINE COOLANT TEMPERATURE GAUGE

MWI

ENGINE COOLANT TEMPERATURE GAUGE : System Diagram

INFOID:0000000005281732

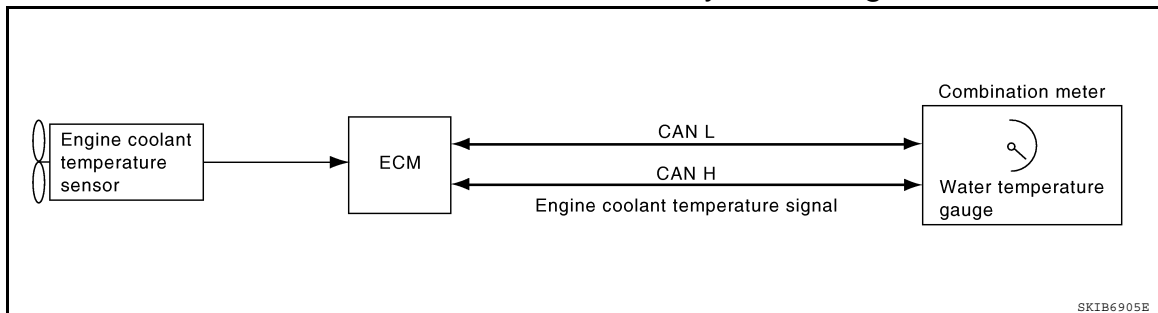

SKIB6905E

METER SYSTEM

< FUNCTION DIAGNOSIS >

ENGINE COOLANT TEMPERATURE GAUGE : System Description

INFOID:000000005281733

The engine coolant temperature gauge indicates the engine coolant temperature. The ECM provides an engine coolant temperature signal to the combination meter via CAN communication lines.

ENGINE COOLANT TEMPERATURE GAUGE : Component Parts Location

INFOID:000000005730707

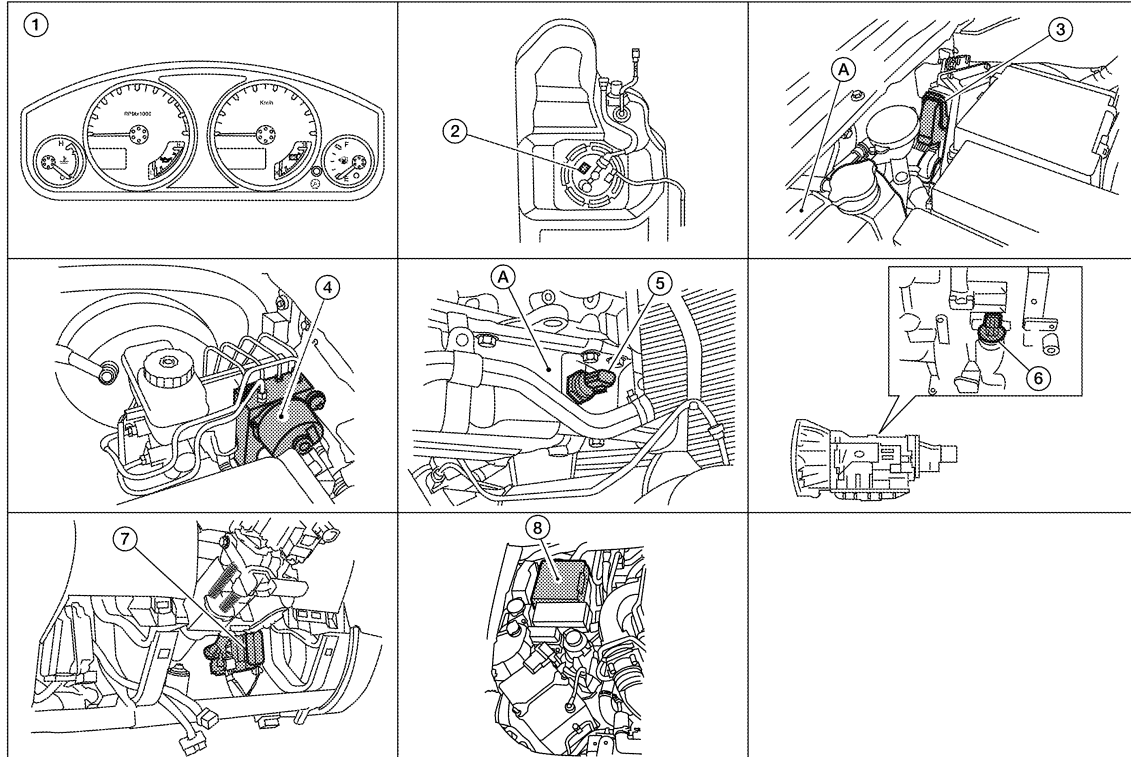

AWNIA10642Z

- | | | |
|---|--|--|
| 1. Combination meter M24 | 2. Fuel level sensor unit and fuel pump C5 (view with fuel tank removed) | 3. ECM E16 (view with ECM cover removed) A. Coolant reservoir |
| 4. ABS actuator and electric unit (control unit) E125 | 5. Oil pressure switch E208 A. Oil pan (upper) | 6. A/T assembly F9 |
| 7. BCM M18, M19 (view with lower instrument panel LH removed) | 8. IPDM E/R E122, E124 | |

ENGINE COOLANT TEMPERATURE GAUGE : Component Description

INFOID:000000005281735

| Unit | Description |
|-------------------|--|
| Combination meter | Indicates the engine coolant temperature according to the engine coolant temperature signal received from ECM via CAN communication. |
| ECM | Transmits the engine coolant temperature signal to the combination meter via CAN communication. |

FUEL GAUGE

METER SYSTEM

< FUNCTION DIAGNOSIS >

FUEL GAUGE : System Diagram

INFOID:000000005281736

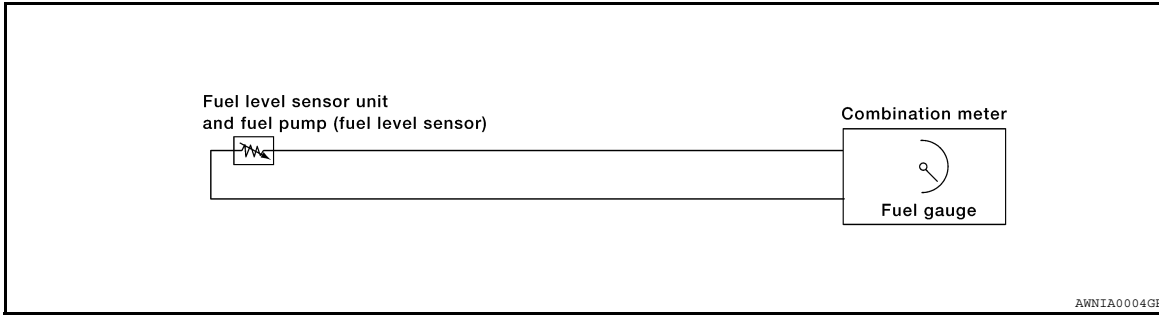

FUEL GAUGE : System Description

INFOID:000000005281737

The fuel gauge indicates the approximate fuel level in the fuel tank. The fuel gauge is regulated by the unified meter control unit and a variable resistor signal supplied by the fuel level sensor unit.

FUEL GAUGE : Component Parts Location

INFOID:000000005730708

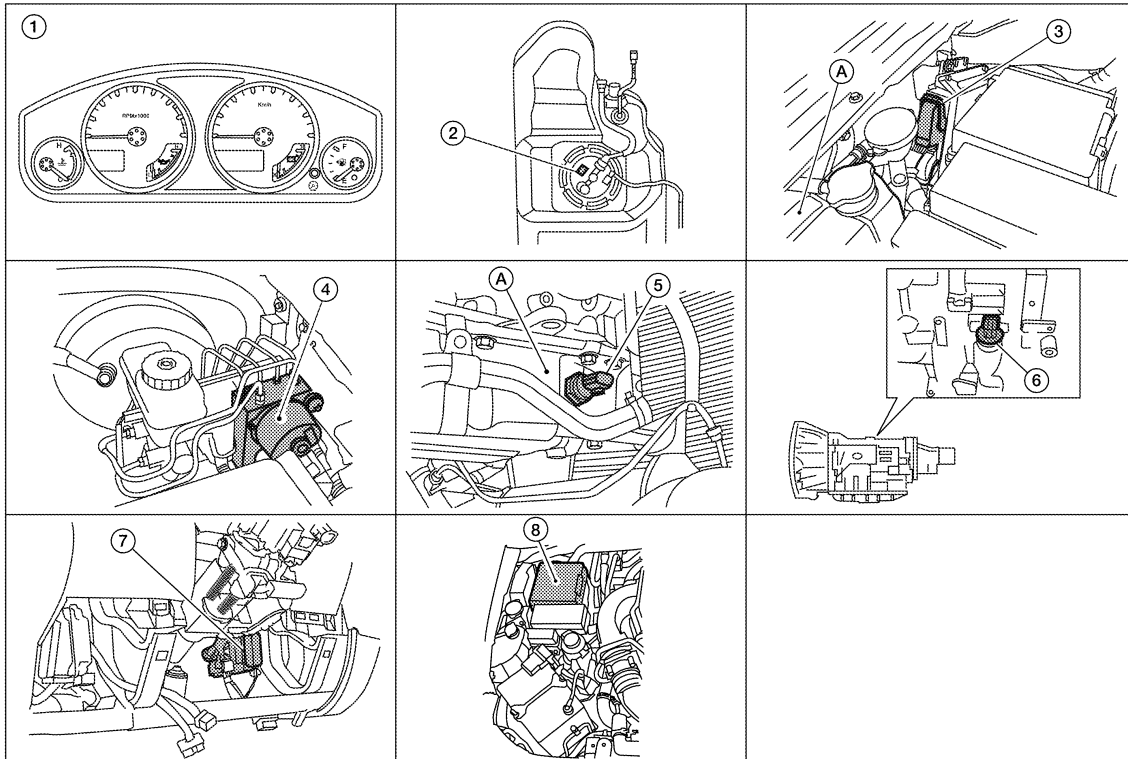

AWNIA1064ZZ

- | | | |
|---|---|--|
| 1. Combination meter M24 | 2. Fuel level sensor unit and fuel pump C5 (view with fuel tank removed) | 3. ECM E16 (view with ECM cover removed) A. Coolant reservoir |
| 4. ABS actuator and electric unit (control unit) E125 | 5. Oil pressure switch E208 A. Oil pan (upper) | 6. A/T assembly F9 |
| 7. BCM M18, M19 (view with lower instrument panel LH removed) | 8. IPDM E/R E122, E124 | |

A
B
C
D
E
F
G
H
I
J
K
L
M
N
O
P



METER SYSTEM

< FUNCTION DIAGNOSIS >

FUEL GAUGE : Component Description

INFOID:000000005281739

| Unit | Description |
|------------------------|--|
| Combination meter | Indicates the fuel level according to the fuel level sensor signal received from the fuel level sensor unit. |
| Fuel level sensor unit | Refer to MWI-30, "Description" . |

ENGINE OIL PRESSURE GAUGE

ENGINE OIL PRESSURE GAUGE : System Diagram

INFOID:000000005281740

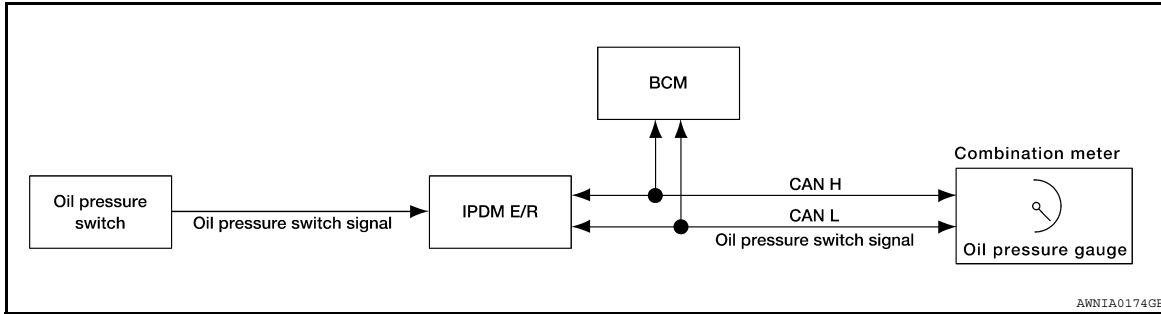

ENGINE OIL PRESSURE GAUGE : System Description

INFOID:000000005281741

The engine oil pressure gauge indicates whether the engine oil pressure is low or normal. The oil pressure gauge is controlled by the IPDM E/R. The IPDM E/R reads the ON/OFF signals from the oil pressure switch and transmits the oil pressure switch signal to the combination meter via BCM with the CAN communication line. The oil pressure gauge displays a low or normal indication according to the oil pressure switch signal received via CAN communication.

ENGINE OIL PRESSURE GAUGE : Component Parts Location

INFOID:000000005730709

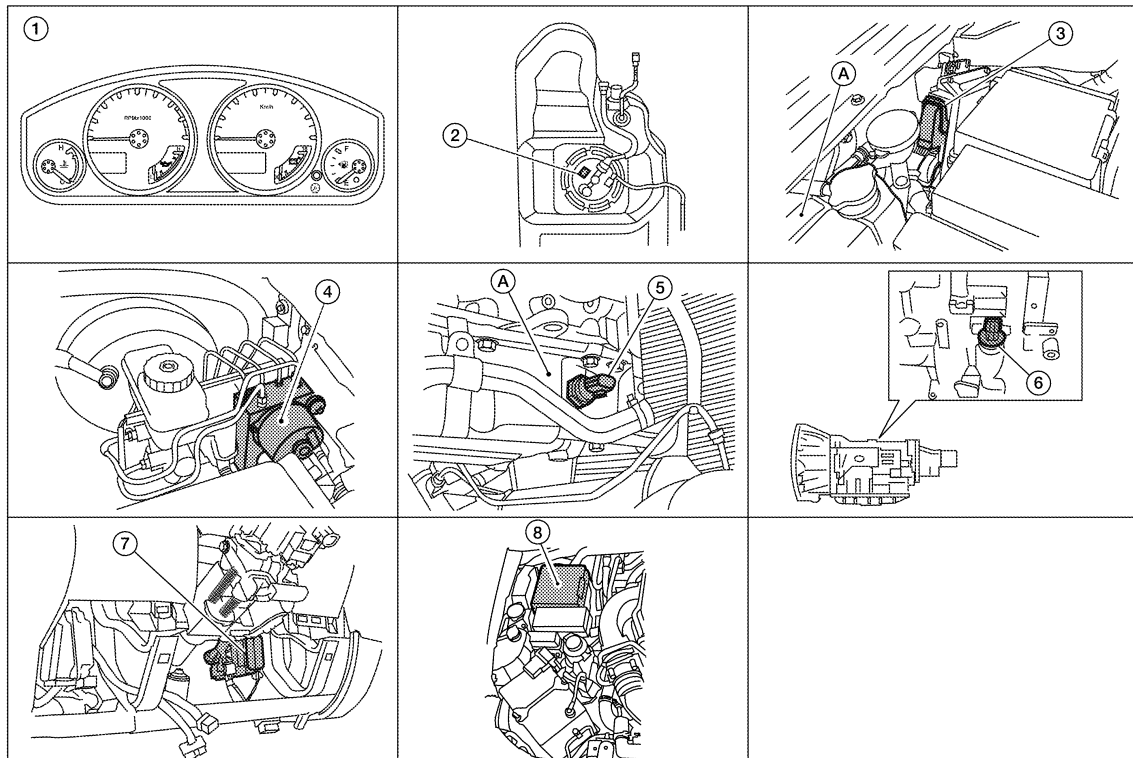

AWNIA10642Z

METER SYSTEM

< FUNCTION DIAGNOSIS >

- | | | |
|---|--|--|
| 1. Combination meter M24 | 2. Fuel level sensor unit and fuel pump C5 (view with fuel tank removed) | 3. ECM E16 (view with ECM cover removed) A. Coolant reservoir |
| 4. ABS actuator and electric unit (control unit) E125 | 5. Oil pressure switch E208 A. Oil pan (upper) | 6. A/T assembly F9 |
| 7. BCM M18, M19 (view with lower instrument panel LH removed) | 8. IPDM E/R E122, E124 | |

ENGINE OIL PRESSURE GAUGE : Component Description

INFOID:000000005281743

| Unit | Description |
|---------------------|--|
| Combination meter | Indicates the engine oil pressure (low/normal) according to the oil pressure switch signal received from BCM with CAN communication line. |
| IPDM E/R | Reads the ON/OFF signals from the oil pressure switch and transmits the oil pressure switch signal to the combination meter via BCM with the CAN communication line. |
| Oil pressure switch | Refer to MWI-33, "Description" . |
| BCM | Transmits the oil pressure switch signal received from IPDM E/R via CAN communication to the combination meter via CAN communication. |

VOLTAGE GAUGE

VOLTAGE GAUGE : System Diagram

INFOID:000000005281744

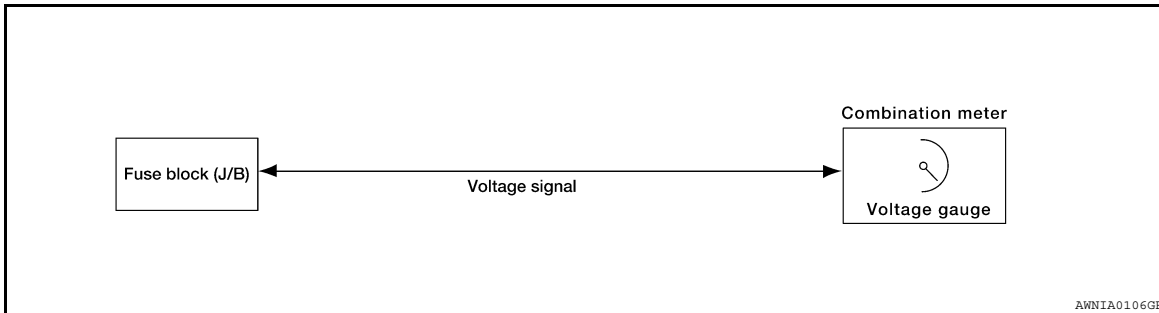

VOLTAGE GAUGE : System Description

INFOID:000000005281745

The voltage gauge indicates the battery/charging system voltage.
The voltage gauge is regulated by the unified meter control unit.

MWI

METER SYSTEM

< FUNCTION DIAGNOSIS >

VOLTAGE GAUGE : Component Parts Location

INFOID:000000005730710

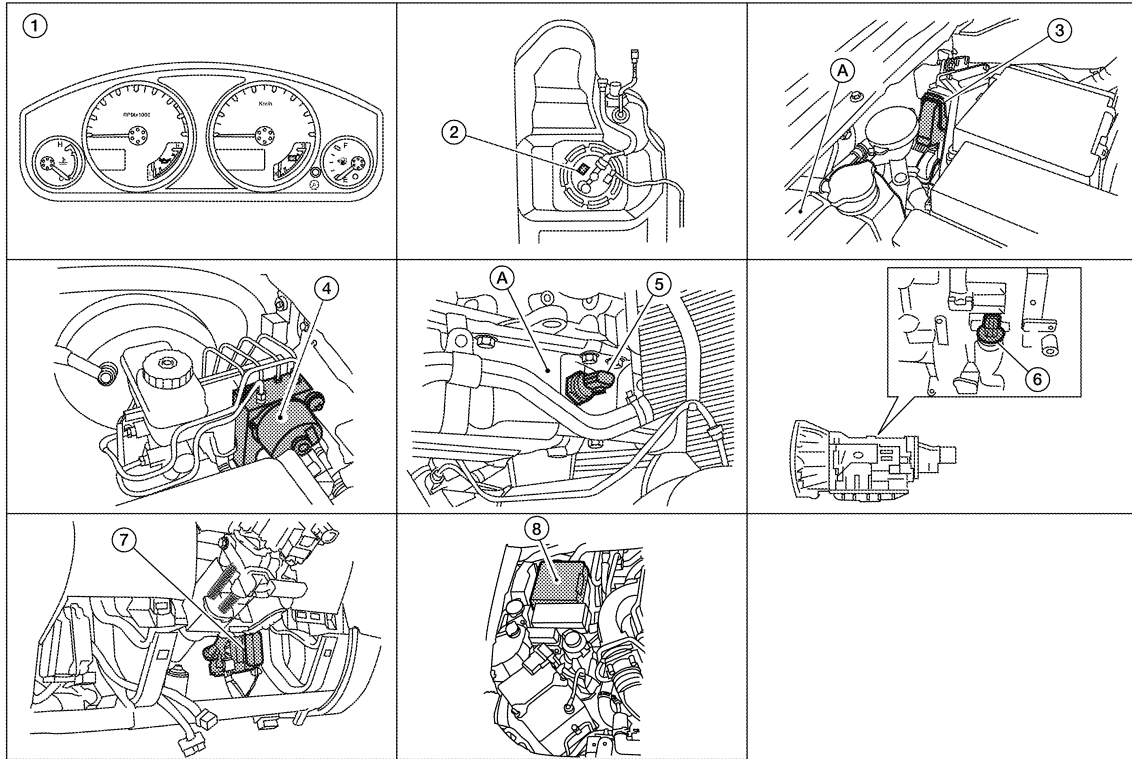

AWNIA10642Z

- | | | |
|---|--|--|
| 1. Combination meter M24 | 2. Fuel level sensor unit and fuel pump C5 (view with fuel tank removed) | 3. ECM E16 (view with ECM cover removed) A. Coolant reservoir |
| 4. ABS actuator and electric unit (control unit) E125 | 5. Oil pressure switch E208 A. Oil pan (upper) | 6. A/T assembly F9 |
| 7. BCM M18, M19 (view with lower instrument panel LH removed) | 8. IPDM E/R E122, E124 | |

VOLTAGE GAUGE : Component Description

INFOID:0000000005281747

| Unit | Description |
|-------------------|---|
| Combination meter | Indicates the battery voltage according to the voltage signal received from the fuse block (J/B). |
| Fuse block (J/B) | Transmits the battery voltage signal to the combination meter. |

ODO/TRIP METER

ODO/TRIP METER : System Diagram

INFOID:0000000005281748

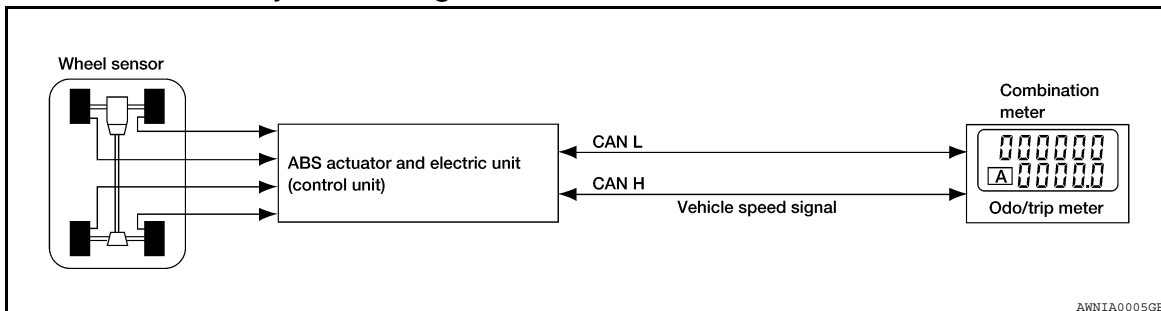

AWNIA0005GB

METER SYSTEM

< FUNCTION DIAGNOSIS >

ODO/TRIP METER : System Description

INFOID:000000005281749

The vehicle speed signal and the memory signals from the meter memory circuit are processed by the combination meter and the mileage is displayed.

HOW TO CHANGE THE DISPLAY FOR ODO/TRIP METER

Refer to Owner's Manual for odo/trip meter operating instructions.

ODO/TRIP METER : Component Parts Location

INFOID:000000005730711

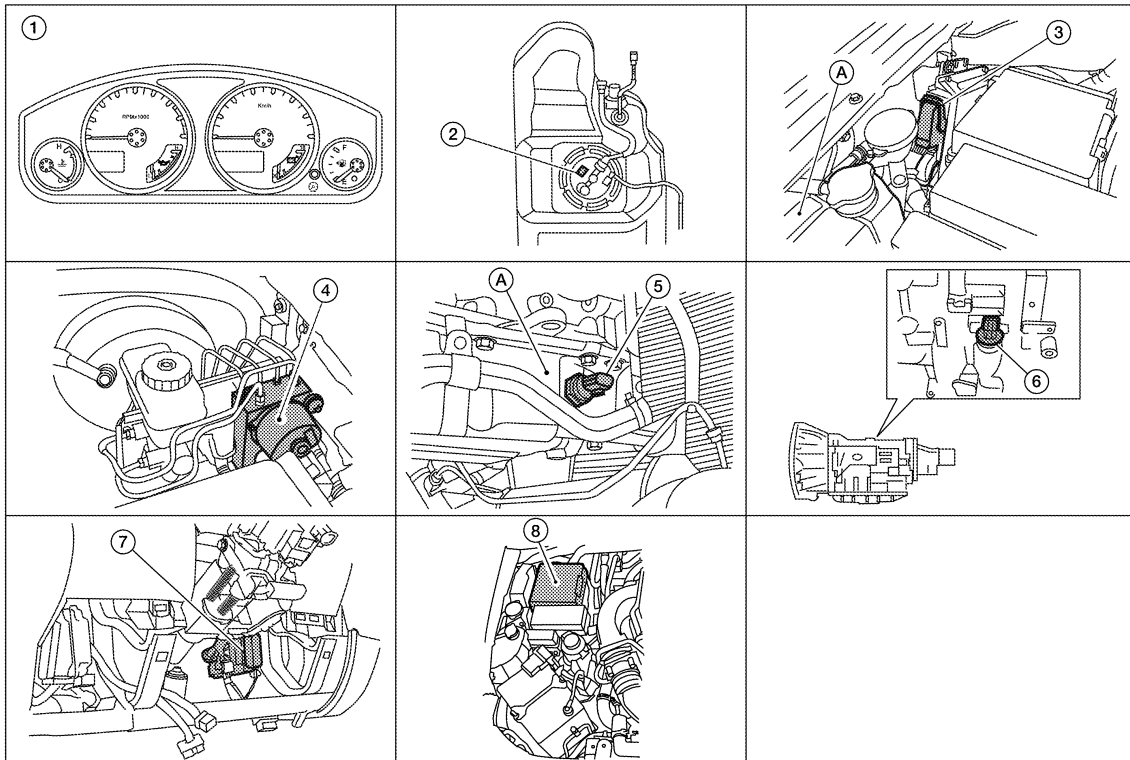

AWNIA1064ZZ

- | | | |
|---|--|--|
| 1. Combination meter M24 | 2. Fuel level sensor unit and fuel pump C5 (view with fuel tank removed) | 3. ECM E16 (view with ECM cover removed) A. Coolant reservoir |
| 4. ABS actuator and electric unit (control unit) E125 | 5. Oil pressure switch E208 A. Oil pan (upper) | 6. A/T assembly F9 |
| 7. BCM M18, M19 (view with lower instrument panel LH removed) | 8. IPDM E/R E122, E124 | |

ODO/TRIP METER : Component Description

INFOID:000000005281751

| Unit | Description |
|---|--|
| Combination meter | Converts the vehicle speed signal received from the ABS actuator and electric unit (control unit) via CAN communication to mileage, and it displays the accumulated mileage to the odo/trip meter. |
| ABS actuator and electric unit (control unit) | Transmits the vehicle speed signal to the combination meter via CAN communication. |

SHIFT POSITION INDICATOR

A
B
C
D
E
F
G
H
I
J
K
L
M
N
O
P

MWI

METER SYSTEM

< FUNCTION DIAGNOSIS >

SHIFT POSITION INDICATOR : System Diagram

INFOID:000000005281752

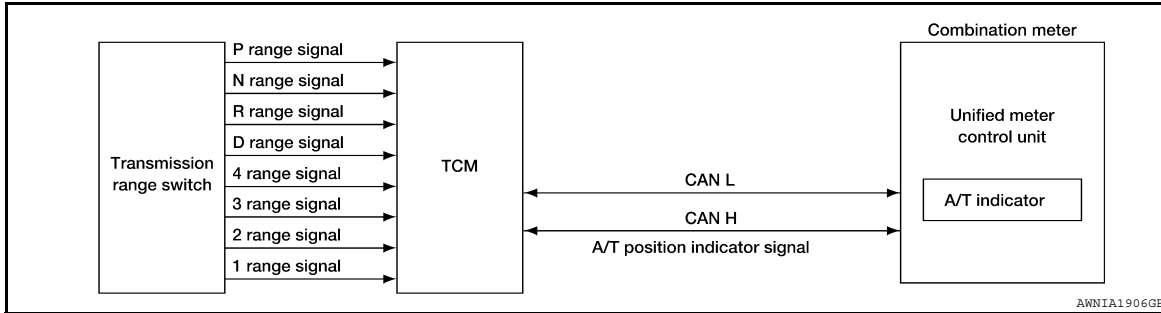

SHIFT POSITION INDICATOR : System Description

INFOID:000000005281753

The TCM receives A/T indicator signals from the transmission range switch. The TCM then sends A/T position indicator signals to the combination meter via CAN communication lines. The combination meter indicates the received shift position.

SHIFT POSITION INDICATOR : Component Parts Location

INFOID:000000005730712

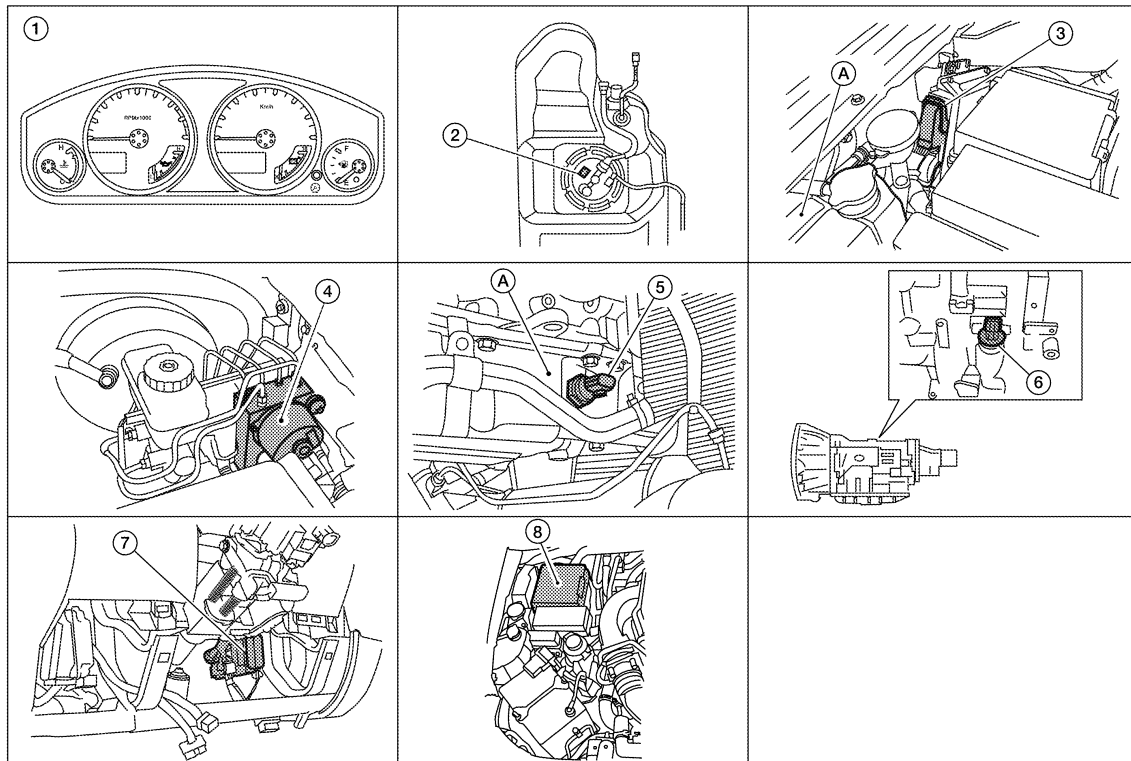

- | | | |
|---|---|--|
| 1. Combination meter M24 | 2. Fuel level sensor unit and fuel pump C5 (view with fuel tank removed) | 3. ECM E16 (view with ECM cover removed) A. Coolant reservoir |
| 4. ABS actuator and electric unit (control unit) E125 | 5. Oil pressure switch E208 A. Oil pan (upper) | 6. A/T assembly F9 |
| 7. BCM M18, M19 (view with lower instrument panel LH removed) | 8. IPDM E/R E122, E124 | |

METER SYSTEM

< FUNCTION DIAGNOSIS >

SHIFT POSITION INDICATOR : Component Description

INFOID:000000005281755

| Unit | Description |
|-------------------|---|
| Combination meter | Displays the shift position using shift position signal received from TCM. |
| TCM | Transmits the shift position signal to the combination meter via CAN communication. |

WARNING LAMPS/INDICATOR LAMPS

WARNING LAMPS/INDICATOR LAMPS : System Diagram

INFOID:000000005281756

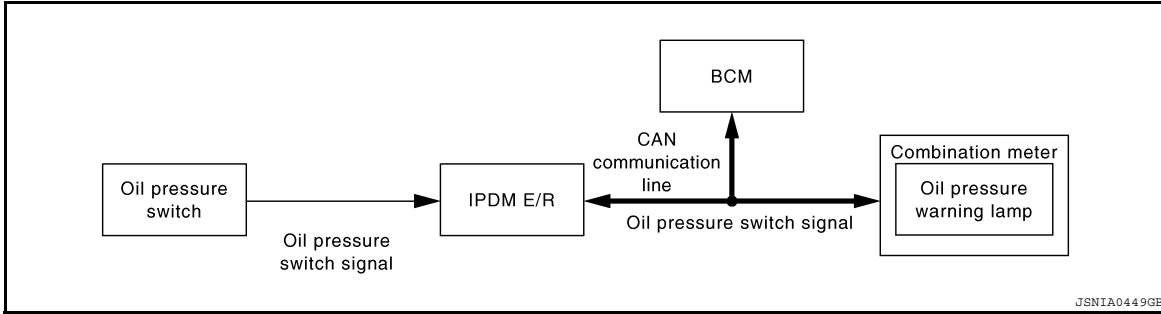

WARNING LAMPS/INDICATOR LAMPS : System Description

INFOID:000000005281757

OIL PRESSURE WARNING LAMP

- IPDM E/R reads the ON/OFF signals from the oil pressure switch and transmits the oil pressure switch signal to the combination meter via BCM with the CAN communication line.
- The combination meter turns the oil pressure warning lamp ON/OFF according to the oil pressure switch signal received via CAN communication.

WARNING LAMPS/INDICATOR LAMPS : Component Parts Location

INFOID:000000005730713

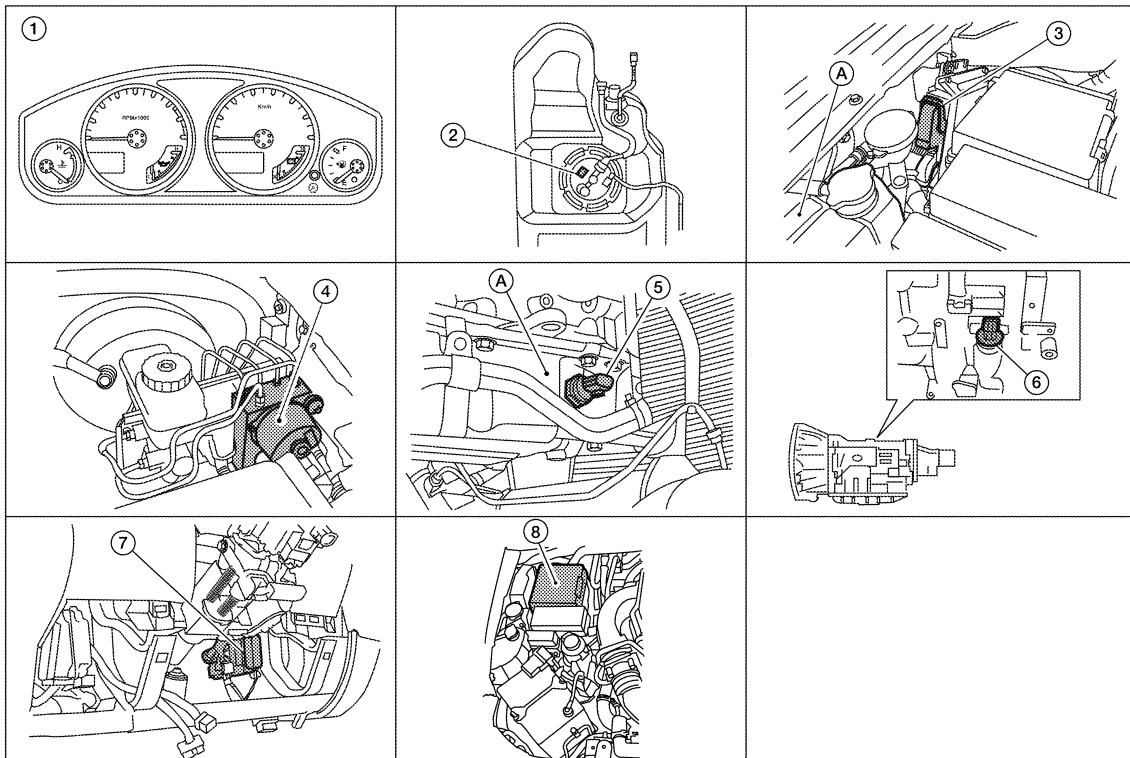

AWNIA1064ZZ

METER SYSTEM

< FUNCTION DIAGNOSIS >

- | | | |
|---|--|--|
| 1. Combination meter M24 | 2. Fuel level sensor unit and fuel pump C5 (view with fuel tank removed) | 3. ECM E16 (view with ECM cover removed) A. Coolant reservoir |
| 4. ABS actuator and electric unit (control unit) E125 | 5. Oil pressure switch E208 A. Oil pan (upper) | 6. A/T assembly F9 |
| 7. BCM M18, M19 (view with lower instrument panel LH removed) | 8. IPDM E/R E122, E124 | |

WARNING LAMPS/INDICATOR LAMPS : Component Description

INFOID:000000005281759

| Unit | Description |
|---------------------|--|
| Combination meter | Turns the oil pressure warning lamp ON/OFF according to the oil pressure switch signal received from BCM by means of communication. |
| IPDM E/R | Reads the ON/OFF signals from the oil pressure switch and transmits the oil pressure switch signal to the combination meter via BCM with the CAN communication line. |
| Oil pressure switch | Refer to MWI-33, "Description" . |
| BCM | Transmits the oil pressure switch signal received from IPDM E/R via CAN communication to the combination meter via CAN communication. |

TRIP COMPUTER

TRIP COMPUTER : System Diagram

INFOID:000000005281760

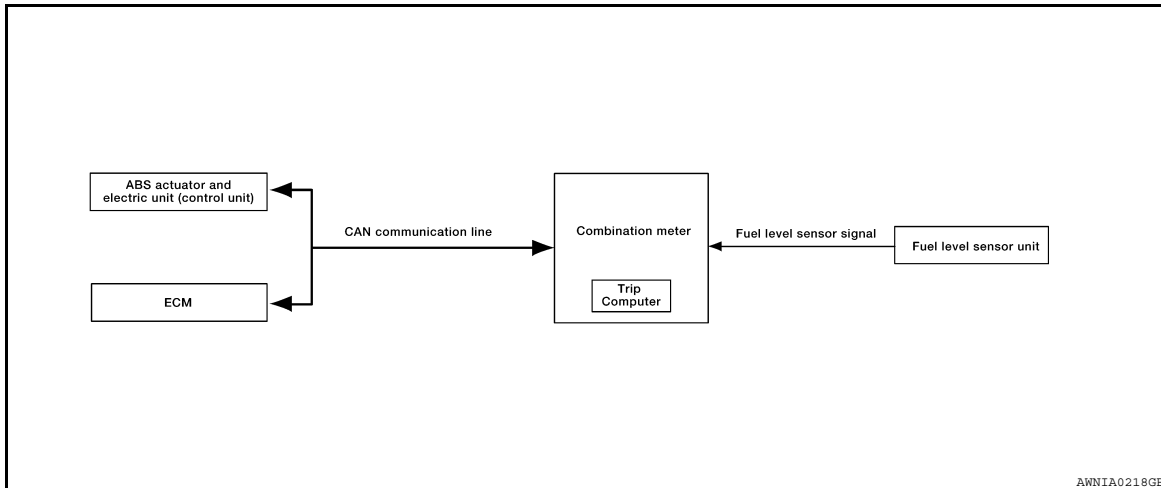

AWNIA0218GB

TRIP COMPUTER : System Description

INFOID:000000005281761

FUNCTION

The trip computer can indicate the following items.

- DTE (distance to empty)
- Trip distance
- Trip time
- Average fuel consumption
- Average vehicle speed

DTE (DISTANCE TO EMPTY) INDICATION

The range indication provides the driver with an estimation of the distance that can be driven before refueling. The range is calculated by signals from the fuel level sensor unit (fuel remaining), ECM (fuel consumption) and the ABS actuator and electric unit (vehicle speed). The indication will be refreshed every 30 seconds. When fuel remaining is less than approximately 11.6 l (3 1/8 US gal, 2 1/2 Imp gal), the indication will blink as a warning. If the fuel remaining is less than approximately 9.6 l (2 1/2 US gal, 2 1/8 Imp gal), the indication will show "---". In this case, the display will change to the DTE mode even though the display is showing a different mode. When the battery is disconnected and reconnected, DTE mode will display "---" until the vehicle is driven 0.3 miles (0.5 km).

METER SYSTEM

< FUNCTION DIAGNOSIS >

TRIP DISTANCE

Trip distance is calculated by signal from the ABS actuator and electric unit (vehicle speed). If trip distance is reset, trip time will be reset at the same time.

TRIP TIME

Trip time displays cumulative ignition switch ON time. If trip time is reset, trip distance will be reset at the same time.

AVERAGE FUEL CONSUMPTION

Average fuel consumption indication is calculated by signals from the ABS actuator and electric unit (vehicle speed) and the ECM (fuel consumption). The indication will be refreshed every 30 seconds.

AVERAGE VEHICLE SPEED

Average vehicle speed indication is calculated by running distance and running time. The indication will be refreshed every 30 seconds. If average vehicle speed is reset, average fuel consumption will be reset at the same time. After resetting, the display will show "---" for 30 seconds.

HOW TO CHANGE/RESET INDICATION

Refer to Owner's Manual for trip computer operating instructions.

TRIP COMPUTER : Component Parts Location

INFOID:000000005730714

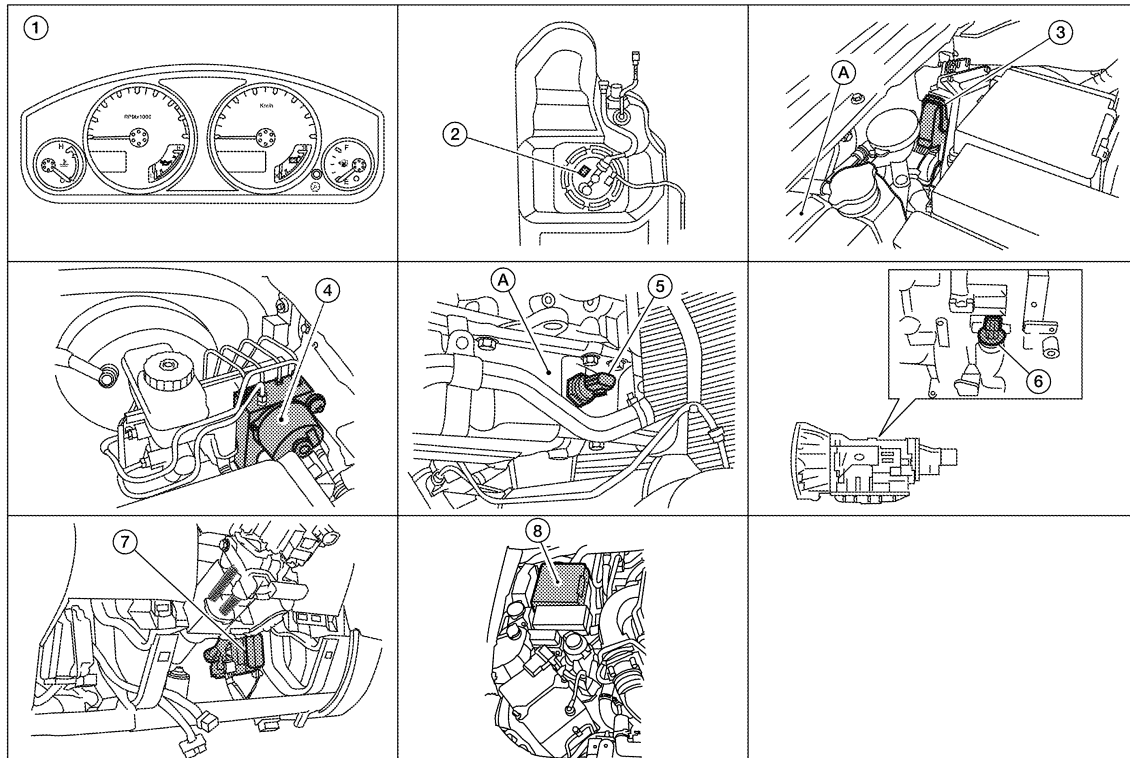

AWNIA1064ZZ

- | | | |
|---|---|--|
| 1. Combination meter M24 | 2. Fuel level sensor unit and fuel pump C5 (view with fuel tank removed) | 3. ECM E16 (view with ECM cover removed) A. Coolant reservoir |
| 4. ABS actuator and electric unit (control unit) E125 | 5. Oil pressure switch E208 A. Oil pan (upper) | 6. A/T assembly F9 |
| 7. BCM M18, M19 (view with lower instrument panel LH removed) | 8. IPDM E/R E122, E124 | |

TRIP COMPUTER : Component Description

INFOID:000000005281763

METER SYSTEM

< FUNCTION DIAGNOSIS >

| Unit | Description |
|---|--|
| Combination meter | Controls the information display according to the signal received from each unit. |
| Fuel level sensor unit | Refer to MWI-30. "Description" . |
| ECM | Transmits the following signals to the combination meter via CAN communication line. <ul style="list-style-type: none">• Engine speed signal• Fuel consumption monitor signal |
| ABS actuator and electric unit (control unit) | Transmits the vehicle speed signal to the combination meter via CAN communication line. |

DIAGNOSIS SYSTEM (METER)

< FUNCTION DIAGNOSIS >

DIAGNOSIS SYSTEM (METER)

Diagnosis Description

INFOID:000000005281764

SELF-DIAGNOSIS MODE

The following items can be checked during Combination Meter Self-Diagnosis Mode.

- Gauge sweep and present gauge values.
- Illuminates all odometer/trip meters and A/T indicator segments.
- Illuminates all micro controlled lamps/LEDs regardless of switch position.
- Displays estimated present battery voltage.
- Displays seat belt buckle switch LH status.

OPERATION PROCEDURE

NOTE:

- Once entered, combination meter self-diagnosis mode will function with the ignition switch in ON or START. Combination meter self-diagnosis mode will exit upon turning the ignition switch to OFF or ACC.
- If the diagnosis function is activated with trip A displayed, the mileage on trip A is reset to 0000.0. (Trip B operates the same way.)

To initiate combination meter self-diagnosis mode, refer to the following procedure.

1. Turn the ignition switch ON, while pressing the odometer/trip meter switch for 5 - 8 seconds. When the diagnosis function is activated, the odometer/trip meter will display tEst.

NOTE:

Check combination meter power supply and ground circuit when self-diagnosis mode of combination meter does not start. Refer to [MWI-27, "COMBINATION METER : Diagnosis Procedure"](#). Replace combination meter if normal. Refer to [MWI-86, "Removal and Installation"](#).

COMBINATION METER SELF-DIAGNOSIS MODE FUNCTIONS

To interpret combination meter self-diagnosis mode functions, refer to the following table.

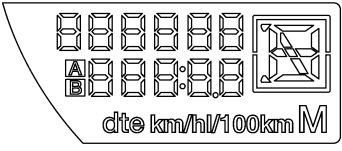
| Event | Odometer Display | Description of Test/Data | Notes: |
|---|----------------------------|---|---|
| Odometer/trip meter A/B switch held from 5 to 8 seconds (or until released) | tEst | | Initiating self-diagnosis mode |
| Switch released | GAGE | Performs sweep of all gauges, then displays present gauge values. | Gauges sweep within 10 seconds |
| Switch pressed | (All segments illuminated) | Lights all LCD segments. Compare with picture. |  AWNIA0220ZZ |
| Switch pressed | bulb | Illuminates all micro-controlled lamps/LEDs. | Part may not be configured for all lamps (functions) that turn on during test. This is normal. |
| Switch pressed | r XXXX, FAIL | Return to normal operation of all lamps/LEDs and displays "r XXXX". | If a malfunction exists, "FAIL" will flash. |
| Switch pressed | nrXXXX | Displays Hex ROM rev as stored in NVM. | |
| Switch pressed | EE XX, FAIL | Displays "EE XX". | If a malfunction exists, "FAIL" will flash. |
| Switch pressed | dtXXXX | Hex coding of final manufacturing test date. | |

DIAGNOSIS SYSTEM (METER)

< FUNCTION DIAGNOSIS >

| Event | Odometer Display | Description of Test/Data | Notes: |
|---------------------------|-----------------------|---|---|
| Switch pressed (3 times) | Sc1 XX through Epr XX | Displays 8 bit software configuration value in Hex format | |
| Switch pressed | 1nF XX | Displays 8-bit market info value in Hex format. | \$31 = USA \$2A = Canada \$23 = EUR-R \$1C = EUR-L \$38 = Japan \$15 = Australia \$0E = Middle East \$FF = Other |
| Switch pressed (3 times) | cYL XX through tF | N/A | |
| Switch pressed | ot1 XX | Displays oil pressure tell-tale "" in Hex format. | |
| Switch pressed | ot0 XX | Displays oil pressure tell-tale "" in Hex format. | |
| Switch pressed | XXXXX | "Corrected" speed value in hundredths of MPH. Gauge indication may be slightly higher. This is normal. | Will display "----" if message is not received. Will display "99999" if data received is invalid. |
| Switch pressed | XXXXX | "Corrected" speed value in hundredths of KPH. Gauge indication may be slightly different. This is normal. | Will display "----" if message is not received. Will display "99999" if data received is invalid. |
| Switch pressed | t XXXX | Tachometer value in RPM. Gauge indication may be higher at higher RPM. This is normal. | Will display "----" if message is not received. |
| Switch pressed | F1XXXX | Present fuel level A/D input. This input represents fuel sender input. | 000-009 = Short circuit 010-254 = Normal range 255 = Open circuit |
| Switch pressed | XXXXC | Last temperature gauge input value in degrees C. Temperature gauge indicates present temperature per indication standard. | Will display "---"C if message is not received. Will display "999" if data received is invalid. High = 130 deg C Normal = 70 - 105 deg C Low = less than 50 deg C |
| Switch pressed | BAtXX.X | Estimated present battery voltage. | |
| Switch pressed | rES -X | Seat belt buckle switch LH status. | 1 = Buckled 0 = Unbuckled |
| Switch pressed (30 times) | PA -XX through PA1-XX | N/A | |
| Switch pressed | GAGE | | Return to beginning of self-diagnosis cycle. |

CONSULT-III Function (METER/M&A)

INFOID:000000005281765

CONSULT-III can display each diagnostic item using the diagnostic test modes shown following.

| METER/M&A diagnosis mode | Description |
|--------------------------|--|
| SELF DIAGNOSTIC RESULT | Displays combination meter self-diagnosis results. |

DIAGNOSIS SYSTEM (METER)

< FUNCTION DIAGNOSIS >

| METER/M&A diagnosis mode | Description |
|--------------------------|--|
| DATA MONITOR | Displays combination meter input/output data in real time. |
| CAN DIAG SUPPORT MNTR | The result of transmit/receive diagnosis of CAN communication can be read. |

SELF-DIAG RESULTS

Display Item List

Refer to [MWI-53, "DTC Index"](#).

DATA MONITOR

Display Item List

X: Applicable

| Display item [Unit] | MAIN SIGNALS | SELECTION FROM MENU | Description |
|------------------------------|--------------|---------------------|--|
| SPEED METER [km/h] or [mph] | X | X | Displays the value of vehicle speed signal. |
| SPEED OUTPUT [km/h] or [mph] | X | X | Displays the value of vehicle speed signal, which is transmitted to each unit with CAN communication. |
| TACHO METER [rpm] | X | X | Displays the value of engine speed signal, which is input from ECM. |
| FUEL METER [lit.] | X | X | Displays the value, which processes a resistance signal from fuel gauge. |
| W TEMP METER [°C] or [°F] | X | X | Displays the value of engine coolant temperature signal, which is input from ECM. |
| ABS W/L [ON/OFF] | | X | Displays [ON/OFF] condition of ABS warning lamp. |
| VDC/TCS IND [ON/OFF] | | X | Displays [ON/OFF] condition of VDC OFF indicator lamp. |
| SLIP IND [ON/OFF] | | X | Displays [ON/OFF] condition of SLIP indicator lamp. |
| BRAKE W/L [ON/OFF] | | X | Displays [ON/OFF] condition of brake warning lamp.* |
| DOOR W/L [ON/OFF] | | X | Displays [ON/OFF] condition of door ajar warning lamp. |
| HI-BEAM IND [ON/OFF] | | X | Displays [ON/OFF] condition of high beam indicator. |
| TURN IND [ON/OFF] | | X | Displays [ON/OFF] condition of turn indicator. |
| OIL W/L [ON/OFF] | | X | Displays [ON/OFF] condition of oil pressure warning lamp. |
| C-ENG W/L [ON/OFF] | | X | Displays [ON/OFF] condition of malfunction indicator lamp. |
| CRUISE IND [ON/OFF] | | X | Displays [ON/OFF] condition of CRUISE indicator. |
| SET IND [ON/OFF] | | X | Displays [ON/OFF] condition of SET indicator. |
| O/D OFF W/L [ON/OFF] | | X | Displays [ON/OFF] condition of O/D OFF warning lamp. |
| FUEL W/L [ON/OFF] | X | X | Displays [ON/OFF] condition of low-fuel warning lamp. |
| AIR PRES W/L [ON/OFF] | | X | Displays [ON/OFF] condition of tire pressure warning lamp. |
| DISTANCE [km] or [mile] | X | X | Displays the value, which is calculated by vehicle speed signal, fuel gauge and fuel consumption from ECM. |
| BUZZER [ON/OFF] | X | X | Displays [ON/OFF] condition of buzzer. |
| BRAKE SW [ON/OFF] | | X | Indicates [ON/OFF] condition of parking brake switch. |
| P RANGE IND [ON/OFF] | X | X | Indicates [ON/OFF] condition of A/T shift P range indicator. |
| R RANGE IND [ON/OFF] | X | X | Indicates [ON/OFF] condition of A/T shift R range indicator. |
| N RANGE IND [ON/OFF] | X | X | Indicates [ON/OFF] condition of A/T shift N range indicator. |
| D RANGE IND [ON/OFF] | X | X | Indicates [ON/OFF] condition of A/T shift D range indicator. |
| 4 RANGE IND [ON/OFF] | X | X | Indicates [ON/OFF] condition of A/T shift 4 range indicator. |
| 3 RANGE IND [ON/OFF] | X | X | Indicates [ON/OFF] condition of A/T shift 3 range indicator. |
| 2 RANGE IND [ON/OFF] | X | X | Indicates [ON/OFF] condition of A/T shift 2 range indicator. |
| 1 RANGE IND [ON/OFF] | X | X | Indicates [ON/OFF] condition of A/T shift 1 range indicator. |
| 4WD LOCK SW [ON/OFF] | | X | Indicates [ON/OFF] condition of 4WD lock switch. |

DIAGNOSIS SYSTEM (METER)

< FUNCTION DIAGNOSIS >

| Display item [Unit] | MAIN SIGNALS | SELECTION FROM MENU | Description |
|------------------------|--------------|---------------------|---|
| 4WD LOCK IND [ON/OFF] | | X | Indicates [ON/OFF] condition of 4WD lock indicator. |
| SEAT BELT W/L [ON/OFF] | | X | Indicates [ON/OFF] condition of seat belt warning lamp. |
| O/D OFF SW [ON/OFF] | | X | Indicates [ON/OFF] condition of O/D OFF switch. |

NOTE:

Some items are not available due to vehicle specification.

*: The monitor will indicate "OFF" even though the brake warning lamp is on if either of the following conditions exist.

- The parking brake is engaged
- The brake fluid level is low

DTC U1000 CAN COMMUNICATION

< COMPONENT DIAGNOSIS >

COMPONENT DIAGNOSIS

DTC U1000 CAN COMMUNICATION

DTC Logic

INFOID:000000005281766

DTC DETECTION LOGIC

| DTC | CONSULT-III display | Detection condition |
|-------|-----------------------|--|
| U1000 | CAN COMM CIRC [U1000] | When combination meter is not receiving CAN communication signals for 2 seconds or more. |

Diagnosis Procedure

INFOID:000000005281767

Symptom: Displays "CAN COMM CIRC [U1000]" as a self-diagnosis result of combination meter.

1. CHECK CAN COMMUNICATION

Select "SELF-DIAG RESULTS" mode for "METER/M&A" with CONSULT-III.

>> Go to "LAN system". Refer to [LAN-14. "Trouble Diagnosis Flow Chart"](#).

A
B
C
D
E
F
G
H
I
J
K
L
M
O
P

MWI

DTC B2205 VEHICLE SPEED CIRCUIT

< COMPONENT DIAGNOSIS >

DTC B2205 VEHICLE SPEED CIRCUIT

Description

INFOID:000000005281768

The ABS actuator and electric unit (control unit) provides a vehicle speed signal to the combination meter via CAN communication lines.

DTC Logic

INFOID:000000005281769

| DTC | CONSULT-III display | Detection condition |
|-------|----------------------------|---|
| B2205 | VEHICLE SPEED CIRC [B2205] | Malfunction is detected when an erroneous speed signal is received for 2 seconds or more. |

Diagnosis Procedure

INFOID:000000005281770

Symptom: Displays "VEHICLE SPEED CIRC [B2205]" as a self-diagnosis result of combination meter.

1. CHECK COMBINATION METER INPUT SIGNAL

1. Start engine and select "METER/M&A" on CONSULT-III.
2. Using "SPEED METER" on "DATA MONITOR", compare the value of DATA MONITOR with speedometer pointer of combination meter. Speedometer and DATA MONITOR indications should be close.

Is the inspection result normal?

- YES >> Perform ABS actuator and electric unit (control unit) self-diagnosis. Refer to [BRC-15, "CONSULT-III Function \(ABS\)"](#) (ABS) or [BRC-85, "CONSULT-III Function \(ABS\)"](#) (VDC/TCS/ABS).
- NO >> Replace combination meter. Refer to [MWI-86, "Removal and Installation"](#).

POWER SUPPLY AND GROUND CIRCUIT

< COMPONENT DIAGNOSIS >

POWER SUPPLY AND GROUND CIRCUIT COMBINATION METER

COMBINATION METER : Diagnosis Procedure

INFOID:000000005281771

Regarding Wiring Diagram information, refer to [MWI-36. "Wiring Diagram"](#).

1. CHECK FUSES

Check for blown combination meter fuses.

| Unit | Power source | Fuse No. |
|-------------------|-----------------------------|----------|
| Combination meter | Battery | 19 |
| | Ignition switch ON or START | 14 |

Is the inspection result normal?

YES >> GO TO 2

NO >> If fuse is blown, be sure to eliminate cause of malfunction before installing new fuse.

2. POWER SUPPLY CIRCUIT CHECK

1. Disconnect combination meter connector M24.
2. Check voltage between combination meter harness connector M24 terminals 3, 16 and ground.

| Terminals | | (-) | Ignition switch position | | |
|-----------|----------|--------|--------------------------|-----------------|-----------------|
| (+) | | | OFF | ACC | ON |
| Connector | Terminal | Ground | | | |
| M24 | 3 | | | Battery voltage | Battery voltage |
| | 16 | | 0V | 0V | Battery voltage |

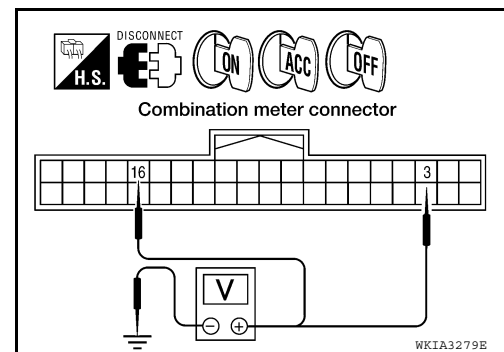

Is the inspection result normal?

YES >> GO TO 3

NO >> Check harness for open between combination meter and fuse.

3. GROUND CIRCUIT CHECK

1. Turn ignition switch OFF.
2. Check continuity between combination meter harness connector M24 terminals 13, 23 and ground.

| Terminals | | (-) | Continuity |
|-----------|----------|--------|------------|
| (+) | | | |
| Connector | Terminal | Ground | Yes |
| M24 | 13 | | |
| | 23 | | |

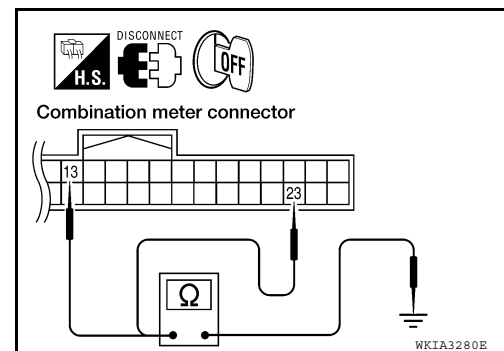

Is the inspection result normal?

YES >> Inspection End.

NO >> Check ground harness.

BCM (BODY CONTROL MODULE)

A
B
C
D
E
F
G
H
I
J
K
L
M
MWI
O
P

POWER SUPPLY AND GROUND CIRCUIT

< COMPONENT DIAGNOSIS >

BCM (BODY CONTROL MODULE) : Diagnosis Procedure

INFOID:000000005712956

Regarding Wiring Diagram information, refer to [BCS-48. "Wiring Diagram"](#).

1. CHECK FUSES AND FUSIBLE LINK

Check that the following fuses and fusible link are not blown.

| Terminal No. | Power Source | Fuses and fusible link No. |
|--------------|----------------------|----------------------------|
| 57 | Battery power supply | 18 (10A) |
| 70 | | G (50A) |
| 11 | Ignition ACC or ON | 4 (10A) |
| 38 | Ignition ON or START | 1 (10A) |

Is the fuse blown?

YES >> Replace the blown fuse or fusible link after repairing the affected circuit.

NO >> GO TO 2

2. CHECK POWER SUPPLY CIRCUIT

1. Turn ignition switch OFF.
2. Disconnect BCM.
3. Check voltage between BCM harness connector and ground.

| Connector | Terminals | | Power source | Condition | Voltage (V) (Approx.) |
|-----------|-----------|--------|-----------------------|-----------------------------|-----------------------|
| | (+) | (-) | | | |
| M18 | 11 | Ground | ACC power supply | Ignition switch ACC or ON | Battery voltage |
| | 38 | Ground | Ignition power supply | Ignition switch ON or START | Battery voltage |
| M20 | 57 | Ground | Battery power supply | Ignition switch OFF | Battery voltage |
| | 70 | Ground | Battery power supply | Ignition switch OFF | Battery voltage |

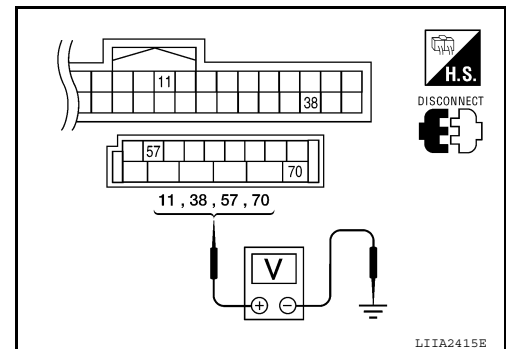

Is the measurement value normal?

YES >> GO TO 3

NO >> Repair or replace harness.

3. CHECK GROUND CIRCUIT

Check continuity between BCM harness connector and ground.

| BCM | | Ground | Continuity |
|-----------|----------|--------|------------|
| Connector | Terminal | | |
| M20 | 67 | | Yes |

Does continuity exist?

YES >> Inspection End.

NO >> Repair or replace harness.

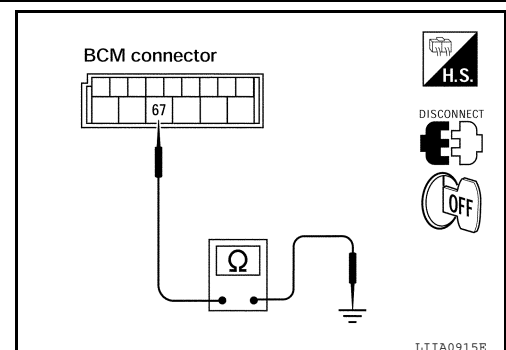

IPDM E/R (INTELLIGENT POWER DISTRIBUTION MODULE ENGINE ROOM)

POWER SUPPLY AND GROUND CIRCUIT

< COMPONENT DIAGNOSIS >

IPDM E/R (INTELLIGENT POWER DISTRIBUTION MODULE ENGINE ROOM) : Diagnosis Procedure

INFOID:000000005712957

Regarding Wiring Diagram information, refer to [MWI-75, "Wiring Diagram"](#).

1. CHECK FUSIBLE LINKS

Check that the following IPDM E/R fusible links are not blown.

| Terminal No. | Signal name | Fusible link No. |
|--------------|-------------|------------------|
| 1 | Battery | A, D |
| 2 | | C |
| 22 | | I |

Is the fusible link blown?

YES >> Replace the blown fusible link after repairing the affected circuit.

NO >> GO TO 2

2. CHECK BATTERY POWER SUPPLY CIRCUIT

- Turn ignition switch OFF.
- Disconnect IPDM E/R.
- Check voltage between IPDM E/R harness connectors and ground.

| Terminals | | (-) | Ignition switch position | Voltage (V) (Approx.) |
|-----------|-----------|--------|--------------------------|-----------------------|
| (+) | Connector | | | |
| E118 (A) | 1 | Ground | OFF | Battery voltage |
| | 2 | | | |
| E120 (B) | 22 | | | |

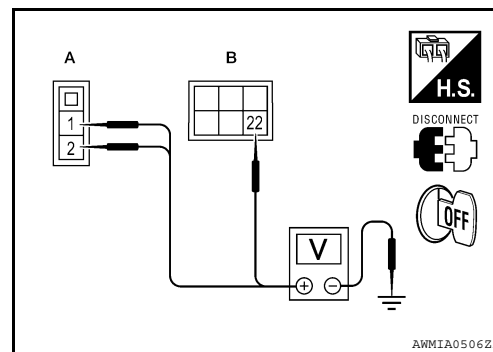

Is there voltage on all pins?

YES >> GO TO 3

NO >> Repair or replace harness.

3. CHECK GROUND CIRCUIT

- Turn ignition switch OFF.
- Check continuity between IPDM E/R harness connectors and ground.

| IPDM E/R | | Ground | Continuity |
|-----------|----------|--------|------------|
| Connector | Terminal | | |
| E122 (A) | 38 | | Yes |
| E124 (B) | 59 | | |

Does continuity exist?

YES >> Inspection End.

NO >> Repair or replace harness.

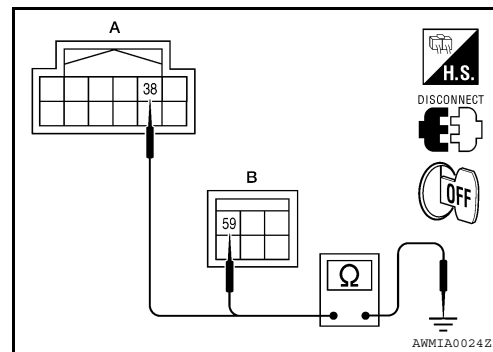

FUEL LEVEL SENSOR SIGNAL CIRCUIT

< COMPONENT DIAGNOSIS >

FUEL LEVEL SENSOR SIGNAL CIRCUIT

Description

INFOID:000000005281774

The fuel level sensor unit and fuel pump detects the approximate fuel level in the fuel tank and transmits the fuel level signal to the combination meter.

Component Function Check

INFOID:000000005281775

1.COMBINATION METER INPUT SIGNAL

1. Select "METER/M&A" on CONSULT-III.
2. Using "FUEL METER" of "DATA MONITOR", compare the value of DATA MONITOR with fuel gauge pointer of combination meter.

| Fuel gauge pointer | Reference value of data monitor [lit.] |
|--------------------|--|
| Full | Approx. 79.3 |
| 3/4 | Approx. 58.5 |
| 1/2 | Approx. 37.1 |
| 1/4 | Approx. 22.4 |
| Empty | Approx. 7.6 |

Does the data monitor value approximately match the fuel gauge indication?

- YES >> Inspection End.
 NO >> Replace combination meter. Refer to [MWI-86. "Removal and Installation"](#).

Diagnosis Procedure

INFOID:000000005281776

Regarding Wiring Diagram information, refer to [MWI-36. "Wiring Diagram"](#).

1.CHECK HARNESS CONNECTOR

1. Turn ignition switch OFF.
2. Check combination meter and fuel level sensor unit terminals (meter-side and harness-side) for poor connection.

Is the inspection result normal?

- YES >> GO TO 2
 NO >> Repair or replace terminals or connectors.

2.CHECK FUEL LEVEL SENSOR UNIT CIRCUIT

1. Disconnect combination meter connector and fuel level sensor unit connector.
2. Check continuity between combination meter harness connector and fuel level sensor unit and fuel pump harness connector.

| Terminals | | | | Continuity |
|-----------|----------|-----------|----------|------------|
| (+) | | (-) | | |
| Connector | Terminal | Connector | Terminal | |
| C5 | 2 | M24 | 9 | Yes |

3. Check continuity between fuel level sensor unit and fuel pump harness connector and ground.

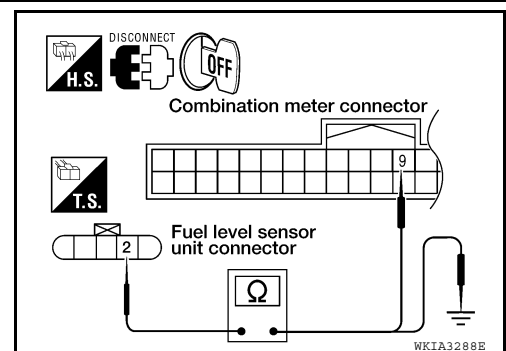

FUEL LEVEL SENSOR SIGNAL CIRCUIT

< COMPONENT DIAGNOSIS >

| Terminals | | Continuity |
|-----------|----------|------------|
| (+) | (-) | |
| Connector | Terminal | Ground |
| C5 | 2 | |
| | | No |

Is the inspection result normal?

YES >> GO TO 3

NO >> Repair harness or connector.

3. CHECK FUEL LEVEL SENSOR UNIT GROUND CIRCUIT

1. Check continuity between combination meter harness connector and fuel level sensor unit and fuel pump harness connector.

| Terminals | | | | Continuity |
|-----------|----------|-----------|----------|------------|
| (+) | | (-) | | |
| Connector | Terminal | Connector | Terminal | Yes |
| C5 | 5 | M24 | 4 | |

2. Check continuity between fuel level sensor unit and fuel pump harness connector and ground.

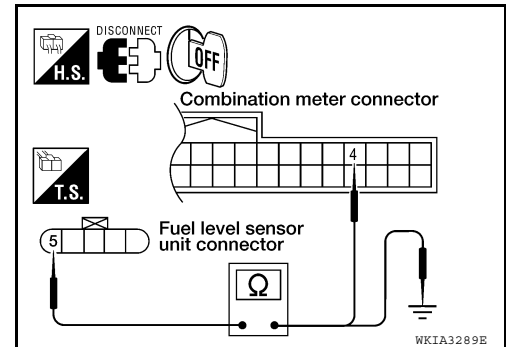

| Terminals | | Continuity |
|-----------|----------|------------|
| (+) | (-) | |
| Connector | Terminal | Ground |
| C5 | 5 | |
| | | No |

Is the inspection result normal?

YES >> GO TO 4

NO >> Repair harness or connector.

4. CHECK INSTALLATION CONDITION

Check fuel level sensor unit installation, and check whether the float arm interferes or binds with any of the internal components in the fuel tank.

Is the inspection result normal?

YES >> Inspection End.

NO >> Install the fuel level sensor unit properly.

Component Inspection

INFOID:000000005281777

1. REMOVE FUEL LEVEL SENSOR UNIT

Remove the fuel level sensor unit. Refer to [FL-11, "Removal and Installation"](#).

>> GO TO 2

2. CHECK FUEL LEVEL SENSOR UNIT AND FUEL PUMP

A
B
C
D
E
F
G
H
I
J
K
L
M
MWI
O
P

FUEL LEVEL SENSOR SIGNAL CIRCUIT

< COMPONENT DIAGNOSIS >

Check the resistance between terminals 2 and 5.

| Terminal | | Float position mm (in) | | Resistance value (Approx.) |
|----------|---|---------------------------|-------|-------------------------------|
| 2 | 5 | *1 | Empty | 10 (0.4) |
| | | *2 | Full | 211.1 (8.3) |

*1 and *2: When float arm is in contact with stopper.

Is inspection result normal?

YES >> Inspection End.

NO >> Replace fuel level sensor unit and fuel pump. Refer to [FL-11, "Removal and Installation"](#).

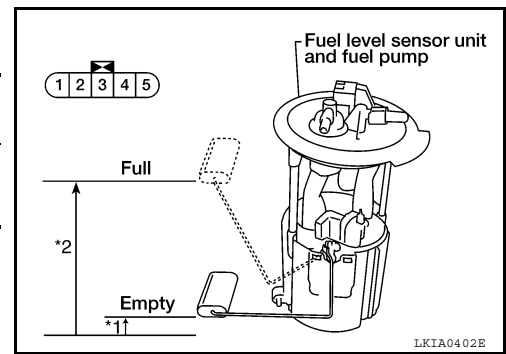

OIL PRESSURE SWITCH SIGNAL CIRCUIT

< COMPONENT DIAGNOSIS >

OIL PRESSURE SWITCH SIGNAL CIRCUIT

Description

INFOID:000000005281778

Detects the engine oil pressure and transmits the oil pressure switch signal to the IPDM E/R.

Component Function Check

INFOID:000000005281779

1.COMBINATION METER INPUT SIGNAL

1. Select "METER/M&A" on CONSULT-III.
2. Monitor "OIL W/L" of "DATA MONITOR" while operating ignition switch.

OIL W/L

When ignition switch is in ON : ON
position (Engine stopped)

When engine is running : OFF

>> Inspection End.

Diagnosis Procedure

INFOID:000000005281780

Regarding Wiring Diagram information, refer to [MWI-36. "Wiring Diagram"](#).

1.CHECK OIL PRESSURE SWITCH CIRCUIT

1. Turn ignition switch OFF.
2. Disconnect IPDM E/R connector E122 and oil pressure switch connector E208.
3. Check continuity between IPDM E/R harness connector E122 (A) terminal 42 and oil pressure switch harness connector E208 (B) terminal 1.

Continuity should exist.

Is the inspection result normal?

- YES >> Inspection End.
NO >> Repair harness or connector.

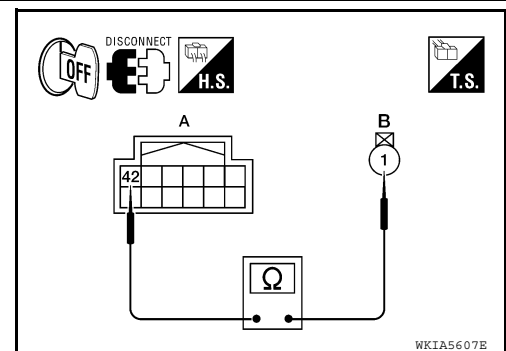

Component Inspection

INFOID:000000005281781

1.CHECK OIL PRESSURE SWITCH

Check continuity between oil pressure switch and ground.

| Condition | Oil pressure [kPa (kg/cm ² , psi)] | Continuity |
|----------------|---|------------|
| Engine stopped | Less than 29 (0.3, 4) | Yes |
| Engine running | More than 29 (0.3, 4) | No |

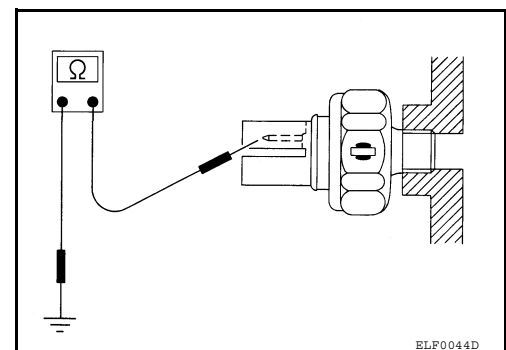

Is the inspection result normal?

- YES >> Inspection End.
NO >> Replace the oil pressure switch.

A
B
C
D
E
F
G
H
I
J
K
L
M
O
P

MWI

COMBINATION METER

< ECU DIAGNOSIS >

ECU DIAGNOSIS

COMBINATION METER

Reference Value

INFOID:000000005281782

TERMINAL LAYOUT

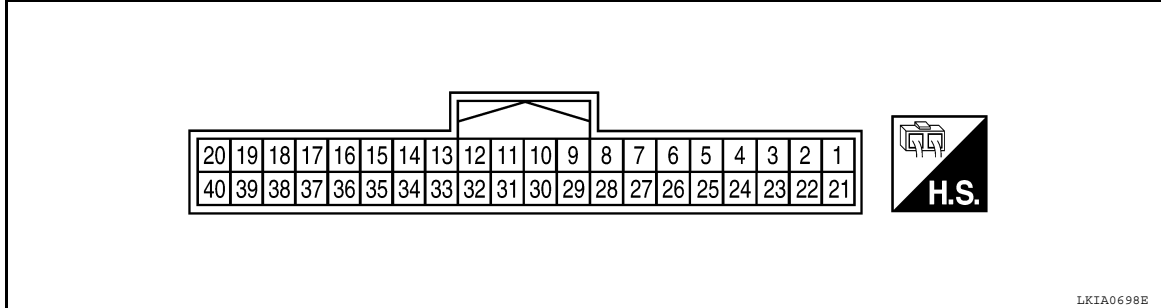

PHYSICAL VALUES

| Terminal | Wire color | Item | Condition | | Reference value (V) (Approx.) |
|----------|------------|---------------------------------------|-----------------|--|--|
| | | | Ignition switch | Operation or condition | |
| 2 | P | Generator | ON | Generator voltage low | 0 |
| | | | | Generator voltage normal | Battery voltage |
| 3 | R/Y | Battery power supply | — | — | Battery voltage |
| 4 | B/Y | Fuel level sensor ground | ON | — | 0 |
| 6 | SB | Vehicle speed signal output (8-pulse) | ON | Speedometer operated [When vehicle speed is approx. 40 km/h (25 MPH)] | <p>NOTE: Maximum voltage may be 12V due to specifications (connected units).</p> <p style="text-align: right;"><small>PKIC0643E</small></p> |
| 9 | BR | Fuel level sensor signal | — | — | Refer to MWI-11, "FUEL GAUGE : System Description" . |
| 11 | P | CAN-L | — | — | — |
| 12 | L | CAN-H | — | — | — |
| 13 | GR | Ground | — | — | 0 |
| 16 | W/G | Ignition switch ON or START | ON | — | Battery voltage |
| 22 | BR | Illumination control switch | — | — | Refer to INL-9, "System Description" . |
| 23 | B | Ground | — | — | 0 |
| 24 | V | Seat belt buckle switch LH | ON | Unfastened (ON) | 0 |
| | | | | Fastened (OFF) | Battery voltage |
| 25 | SB | DIFF LOCK indicator input | ON | DIFF LOCK indicator ON | 0 |
| | | | | DIF LOCK indicator OFF | Battery voltage |
| 31 | G | Parking brake switch | ON | Parking brake applied | 0 |
| | | | | Parking brake released | Battery voltage |

COMBINATION METER

< ECU DIAGNOSIS >

| Terminal | Wire color | Item | Condition | | Reference value (V) (Approx.) | |
|----------|------------|----------------------------|-----------------|---------------------------|----------------------------------|---|
| | | | Ignition switch | Operation or condition | | |
| 32 | SB | Brake fluid level switch | ON | Brake fluid level low | 0 | A |
| | | | | Brake fluid level normal | Battery voltage | B |
| 33 | LG | Stop lamp switch | — | Brake pedal depressed | Battery voltage | |
| | | | | Brake pedal released | 0 | C |
| 34 | L | Washer fluid level switch | ON | Washer fluid level low | 0 | |
| | | | | Washer fluid level normal | Battery voltage | D |
| 37 | SB | Air bag warning lamp input | ON | Air bag warning lamp ON | 4 | E |
| | | | | Air bag warning lamp OFF | 0 | |
| 39 | G | Security indicator input | OFF | Security indicator ON | 0 | E |
| | | | | Security indicator OFF | Battery voltage | |
| 40 | LG | Seat belt buckle switch RH | ON | Unfastened (ON) | 0 | F |
| | | | | Fastened (OFF) | Battery voltage | F |

A
B
C
D
E
F
G
H
I
J
K
L
M

MWI

O
P

COMBINATION METER

< ECU DIAGNOSIS >

Wiring Diagram

INFOID:000000005281783

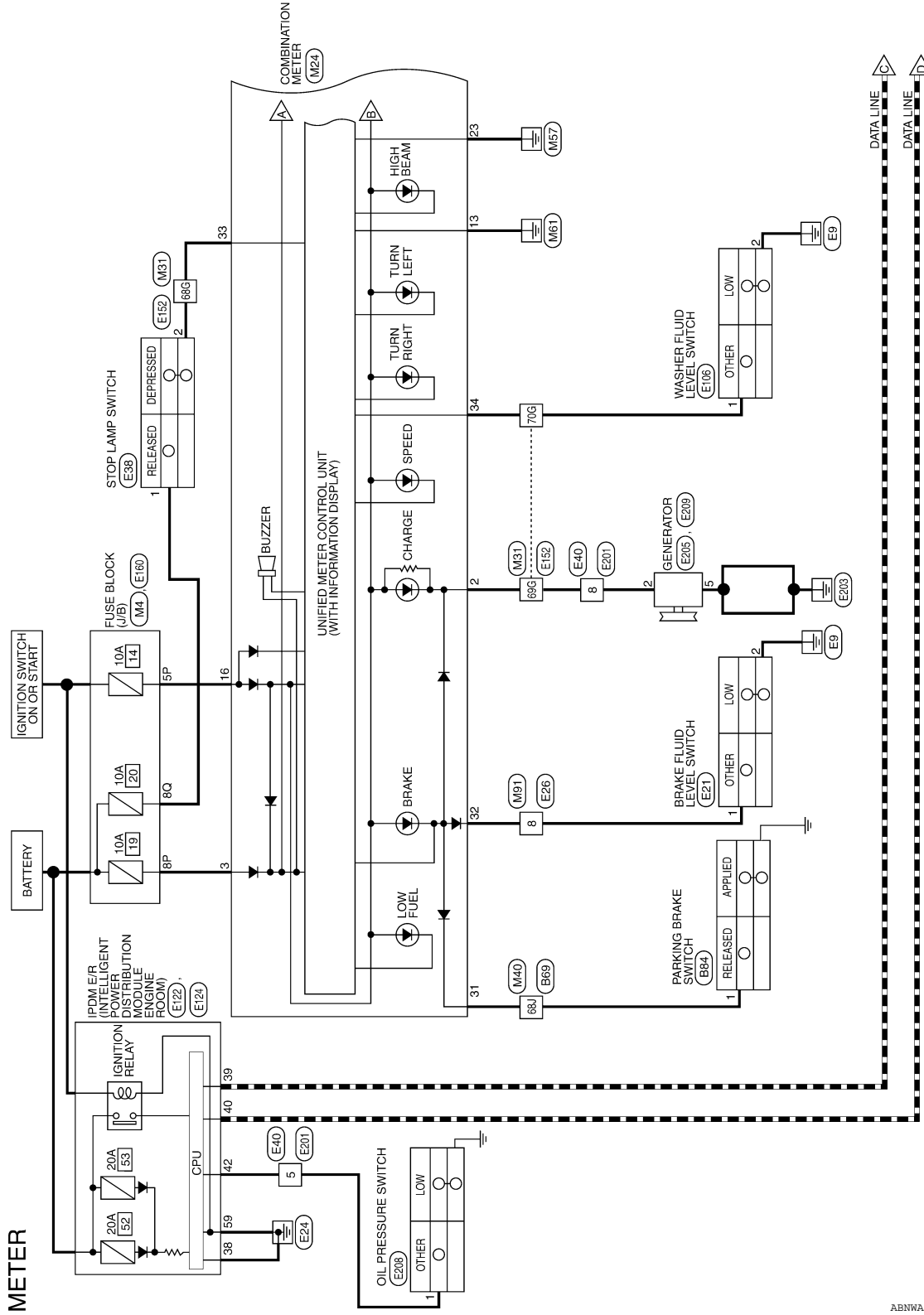

ABNWA0634GB

COMBINATION METER

< ECU DIAGNOSIS >

△ : WITH A/T
 △PA : WITH PREMIUM AUDIO SYSTEM

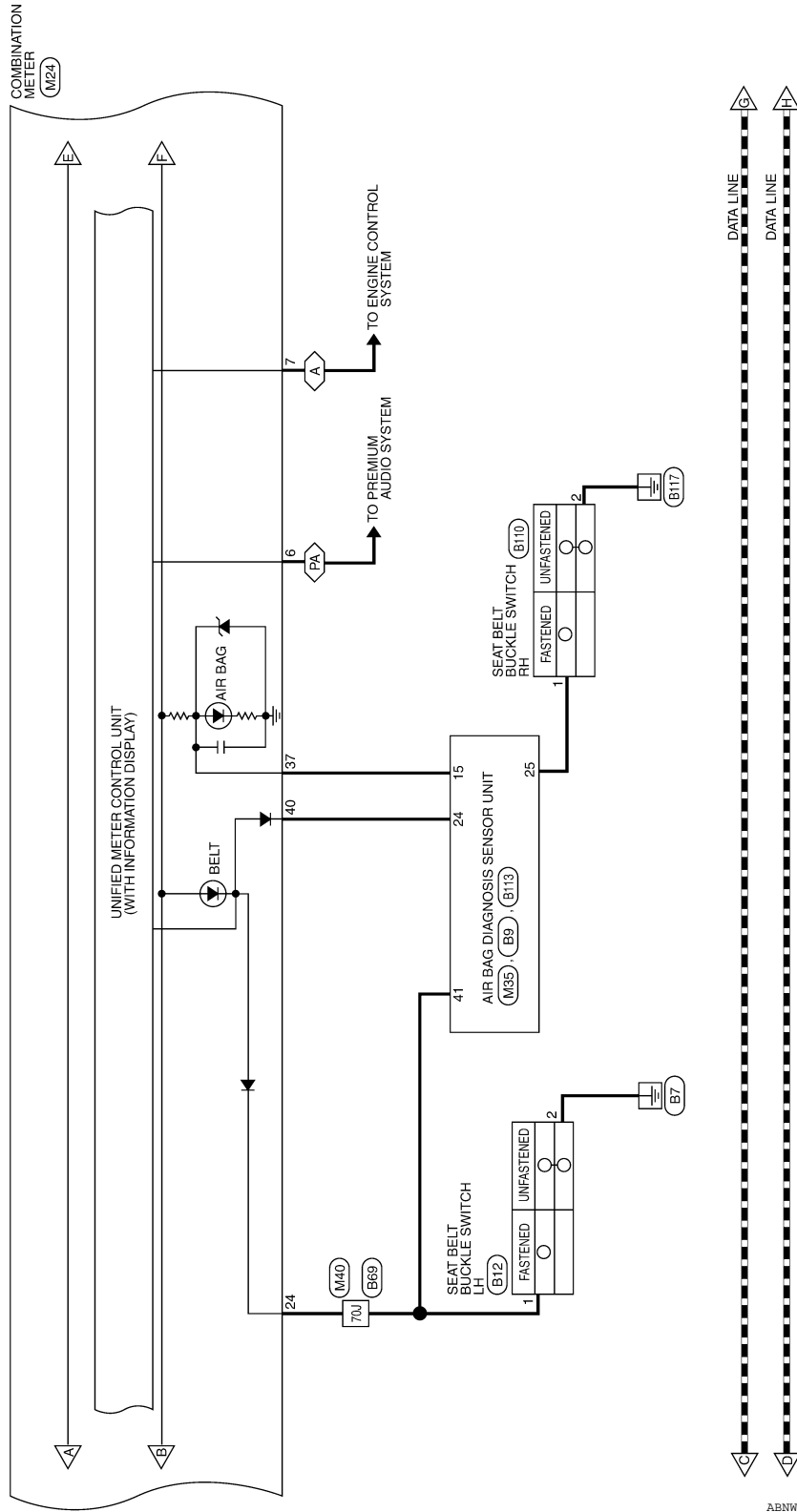

ABNWA0635GB

A
B
C
D
E
F
G
H
I
J
K
L
M
N
O
P

MWI

COMBINATION METER

< ECU DIAGNOSIS >

- *1: : WITH A/T
- : WITH ASCD
- : WITH M/T
- *2: : 13
- : 15
- : WITHOUT VDC
- : WITH VDC

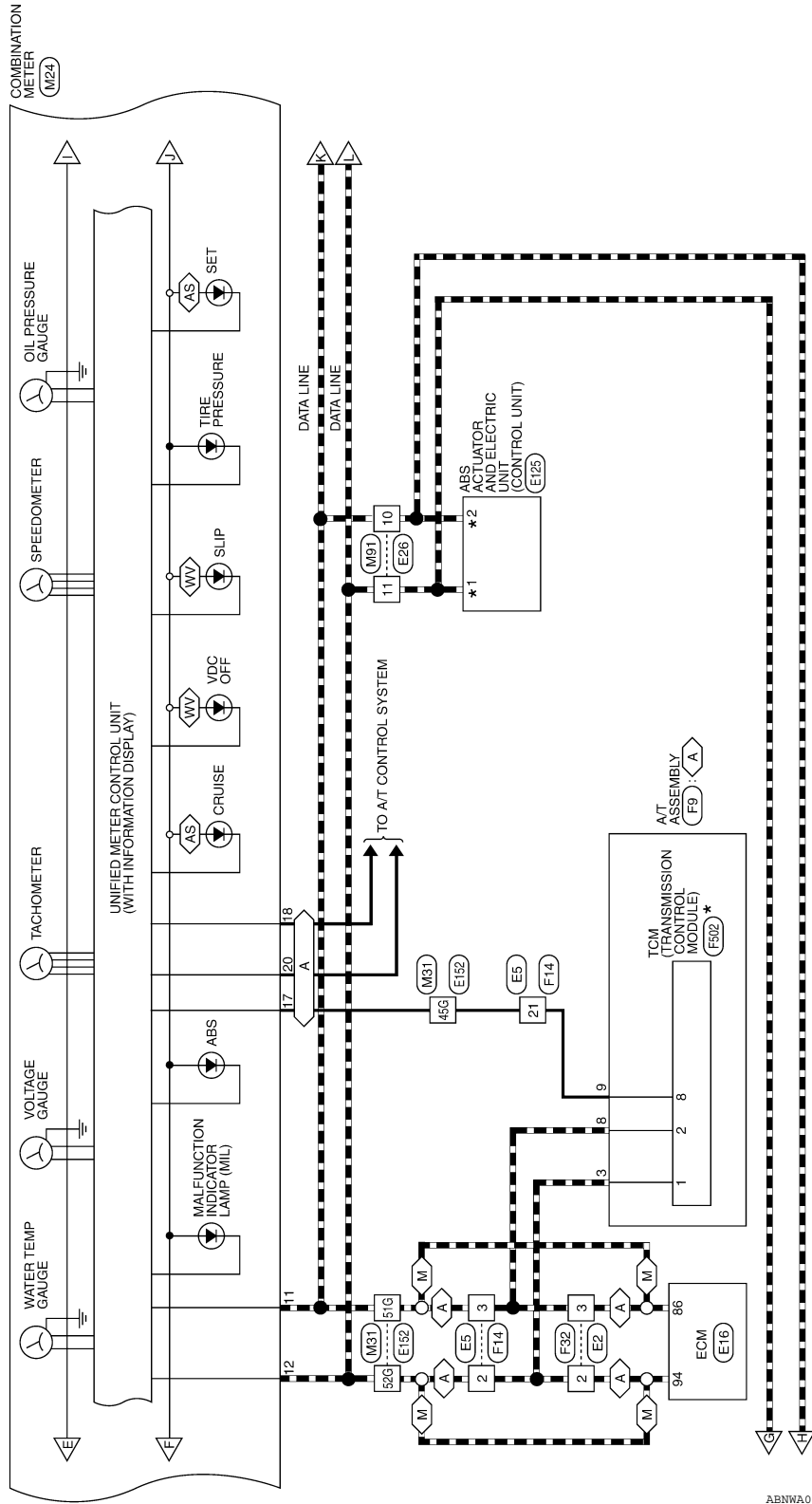

* THIS CONNECTOR IS NOT SHOWN IN "HARNES LAYOUT" OF PG SECTION.

ABNWA0636GB

COMBINATION METER

< ECU DIAGNOSIS >

⬢ WITH A/T

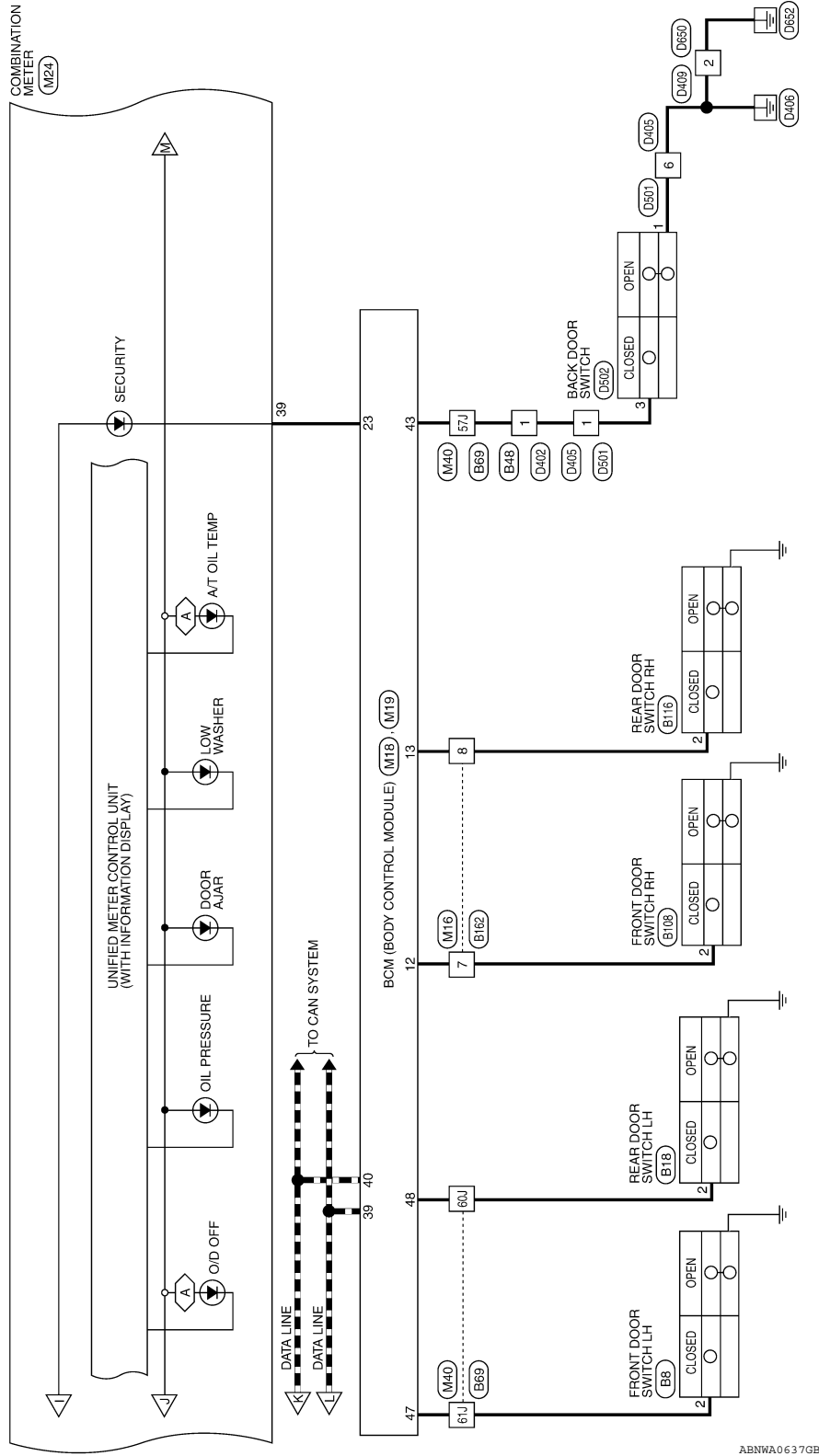

ABNWA0637GB

A
B
C
D
E
F
G
H
I
J
K
L
M
N
O
P

MWI

COMBINATION METER

< ECU DIAGNOSIS >

◊A◊ : WITH A/T
 ◊DL◊ : WITH ELECTRONIC LOCKING REAR DIFFERENTIAL

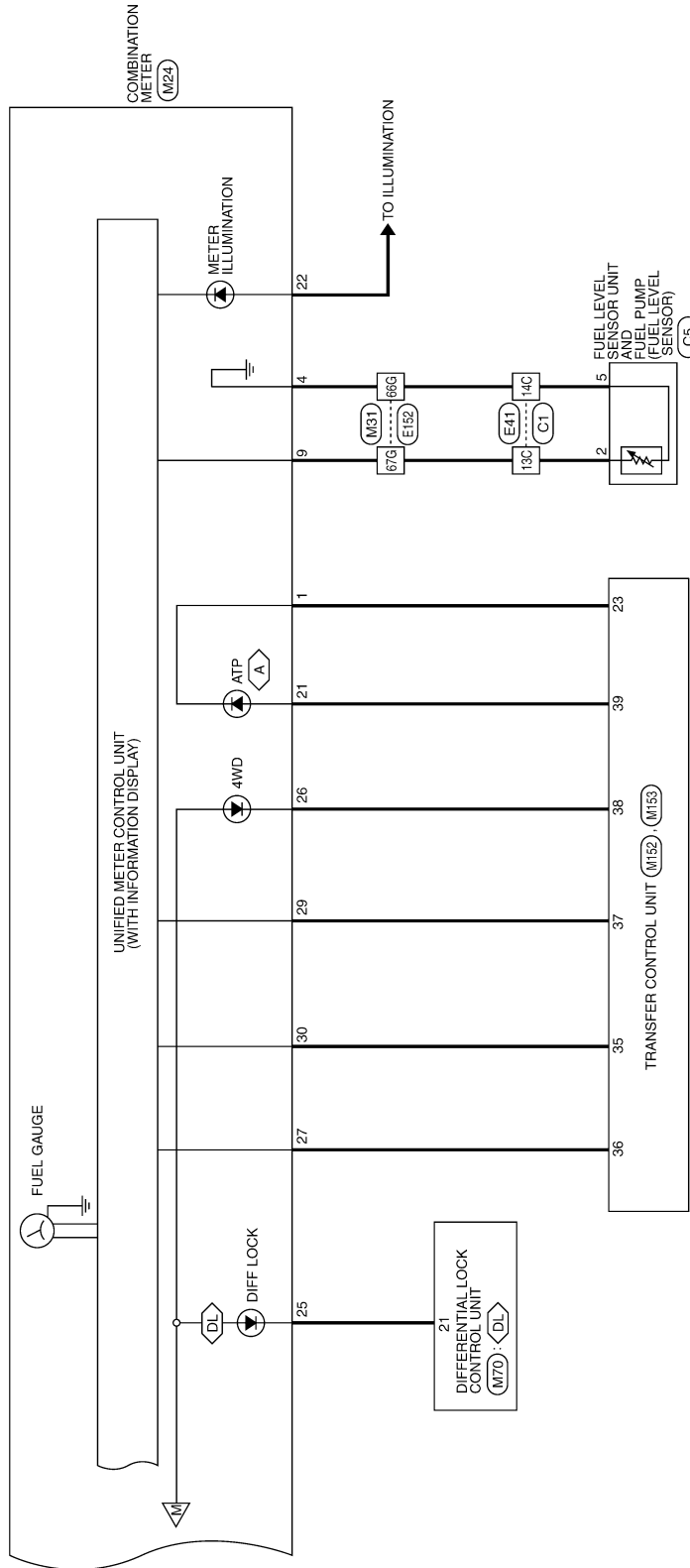

ABNWA063 8GB

COMBINATION METER

< ECU DIAGNOSIS >

METER CONNECTORS

| | |
|-----------------|------------------|
| Connector No. | M4 |
| Connector Name | FUSE BLOCK (J/B) |
| Connector Color | WHITE |



| Terminal No. | Color of Wire | Signal Name |
|--------------|---------------|-------------|
| 5P | W/G | - |
| 8P | R/Y | - |

| | |
|-----------------|--------------|
| Connector No. | M16 |
| Connector Name | WIRE TO WIRE |
| Connector Color | WHITE |

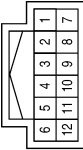

| Terminal No. | Color of Wire | Signal Name |
|--------------|---------------|-------------|
| 7 | LG | - |
| 8 | L | - |

| | |
|-----------------|---------------------------|
| Connector No. | M18 |
| Connector Name | BCM (BODY CONTROL MODULE) |
| Connector Color | WHITE |

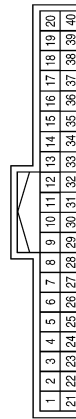

| Terminal No. | Color of Wire | Signal Name |
|--------------|---------------|---------------------------|
| 12 | LG | DOOR SW (AS) |
| 13 | L | DOOR SW (RR) |
| 23 | G | SECURITY INDICATOR OUTPUT |
| 39 | L | CAN-H |
| 40 | P | CAN-L |

| | |
|-----------------|---------------------------|
| Connector No. | M19 |
| Connector Name | BCM (BODY CONTROL MODULE) |
| Connector Color | WHITE |

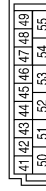

| Terminal No. | Color of Wire | Signal Name |
|--------------|---------------|--------------|
| 43 | Y | BACK DOOR SW |
| 47 | GR | DOOR SW (DR) |
| 48 | P | DOOR SW (RL) |

A
B
C
D
E
F
G
H
I
J
K
L
M
N
O
P



COMBINATION METER

< ECU DIAGNOSIS >

| | |
|-----------------|-------------------|
| Connector No. | M24 |
| Connector Name | COMBINATION METER |
| Connector Color | WHITE |



| | | | | | | | | | | | | | | | | | | | |
|----|----|----|----|----|----|----|----|----|----|----|----|----|----|----|----|----|----|----|----|
| 20 | 19 | 18 | 17 | 16 | 15 | 14 | 13 | 12 | 11 | 10 | 9 | 8 | 7 | 6 | 5 | 4 | 3 | 2 | 1 |
| 40 | 39 | 38 | 37 | 36 | 35 | 34 | 33 | 32 | 31 | 30 | 29 | 28 | 27 | 26 | 25 | 24 | 23 | 22 | 21 |

| Terminal No. | Color of Wire | Signal Name |
|--------------|---------------|--------------------|
| 1 | R | ATP. |
| 2 | P | CHARGE (ALT) INPUT |
| 3 | R/Y | BATTERY |
| 4 | B/Y | FUEL SENDER RETURN |
| 5 | - | - |
| 6 | SB | SPEED OUT 8 |
| 7 | G | AT-PN ECM |
| 8 | - | - |

| Terminal No. | Color of Wire | Signal Name |
|--------------|---------------|----------------------|
| 9 | BR | FUEL SENDER INPUT |
| 10 | - | - |
| 11 | P | CAN-L |
| 12 | L | CAN-H |
| 13 | GR | GROUND |
| 14 | - | - |
| 15 | - | - |
| 16 | W/G | RUN START |
| 17 | B | AT-PN SWITCH |
| 18 | L | AT 1 RANGE SWITCH |
| 19 | - | - |
| 20 | Y | O/D OFF SWITCH |
| 21 | LG | ATP+ |
| 22 | BR | ILLUMINATION CONTROL |
| 23 | B | POWER GND |
| 24 | V | BUCKLE (SEATBELT) SW |

| Terminal No. | Color of Wire | Signal Name |
|--------------|---------------|------------------|
| 25 | SB | DIFF LOCK |
| 26 | GR | 4WD FAIL |
| 27 | BR | 4WD (LOCK) INPUT |
| 28 | - | - |
| 29 | O | 4WD (4 LO) INPUT |
| 30 | V | 4WD (2 WD) INPUT |
| 31 | G | PARK BRAKE SW |
| 32 | SB | BRAKE OIL SWITCH |
| 33 | LG | BRAKE PEDAL SW |
| 34 | L | WASHER FLUID SW |
| 35 | - | - |
| 36 | - | - |
| 37 | SB | AIRBAG CONT |
| 38 | - | - |
| 39 | G | SECURITY |
| 40 | LG | PASS SEATBELT |

| | |
|-----------------|--------------|
| Connector No. | M31 |
| Connector Name | WIRE TO WIRE |
| Connector Color | WHITE |

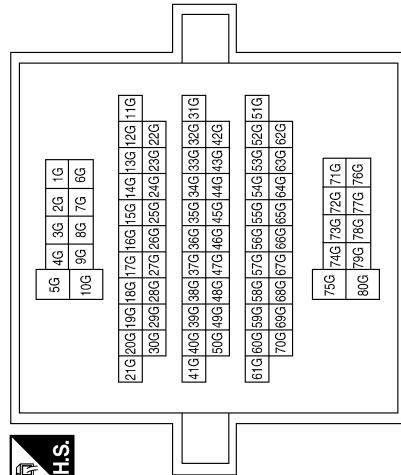

| Terminal No. | Color of Wire | Signal Name |
|--------------|---------------|-------------|
| 45G | B | - |
| 51G | P | - |
| 52G | L | - |
| 66G | B/Y | - |
| 67G | BR | - |
| 68G | LG | - |
| 69G | P | - |
| 70G | L | - |

| | |
|-----------------|-------------------------------|
| Connector No. | M35 |
| Connector Name | AIR BAG DIAGNOSIS SENSOR UNIT |
| Connector Color | YELLOW |

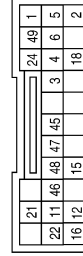

| Terminal No. | Color of Wire | Signal Name |
|--------------|---------------|------------------|
| 15 | SB | AIRBAG W/L |
| 24 | LG | SEAT BELT REMIND |

COMBINATION METER

< ECU DIAGNOSIS >

| | |
|-----------------|--------------|
| Connector No. | M40 |
| Connector Name | WIRE TO WIRE |
| Connector Color | WHITE |

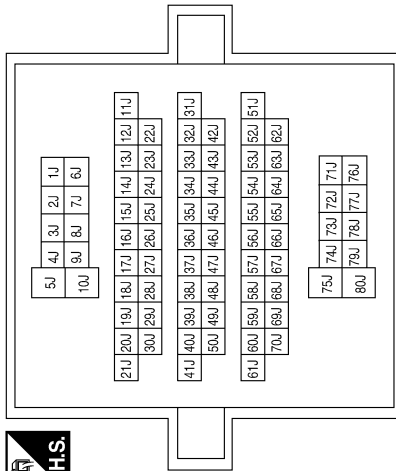

| Terminal No. | Color of Wire | Signal Name |
|--------------|---------------|-------------|
| 57J | Y | - |
| 60J | P | - |
| 61J | GR | - |
| 68J | G | - |
| 70J | V | - |

| | |
|-----------------|--------------------------------|
| Connector No. | M70 |
| Connector Name | DIFFERENTIAL LOCK CONTROL UNIT |
| Connector Color | WHITE |



| Terminal No. | Color of Wire | Signal Name |
|--------------|---------------|---------------|
| 21 | SB | DIFF LOCK IND |

| | |
|-----------------|--------------|
| Connector No. | M91 |
| Connector Name | WIRE TO WIRE |
| Connector Color | WHITE |

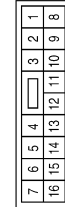

| Terminal No. | Color of Wire | Signal Name |
|--------------|---------------|-------------|
| 8 | SB | - |
| 10 | P | - |
| 11 | L | - |

| | |
|-----------------|-----------------------|
| Connector No. | M152 |
| Connector Name | TRANSFER CONTROL UNIT |
| Connector Color | WHITE |

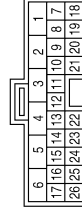

| Terminal No. | Color of Wire | Signal Name |
|--------------|---------------|-------------|
| 23 | R | ATP SW |

| | |
|-----------------|-----------------------|
| Connector No. | M153 |
| Connector Name | TRANSFER CONTROL UNIT |
| Connector Color | WHITE |

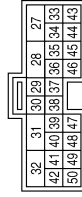

| Terminal No. | Color of Wire | Signal Name |
|--------------|---------------|-------------|
| 35 | V | 2WD IND |
| 36 | BR | LOCK IND |
| 37 | O | 4LO IND |
| 38 | GR | 4WD FAIL |
| 39 | LG | ATP IND |

A
B
C
D
E
F
G
H
I
J
K
L
M
MWI
O
P

ABNIA1876GB

COMBINATION METER

< ECU DIAGNOSIS >

| | |
|-----------------|-------|
| Connector No. | E16 |
| Connector Name | ECM |
| Connector Color | BLACK |

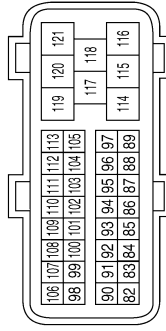

| Terminal No. | Color of Wire | Signal Name |
|--------------|---------------|-------------|
| 86 | P | CAN-L |
| 94 | L | CAN-H |

| | |
|-----------------|--------------|
| Connector No. | E5 |
| Connector Name | WIRE TO WIRE |
| Connector Color | WHITE |

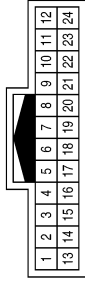

| Terminal No. | Color of Wire | Signal Name |
|--------------|---------------|-------------|
| 2 | L | - |
| 3 | P | - |
| 21 | R | - |

| | |
|-----------------|--------------|
| Connector No. | E2 |
| Connector Name | WIRE TO WIRE |
| Connector Color | WHITE |

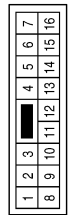

| Terminal No. | Color of Wire | Signal Name |
|--------------|---------------|-------------|
| 2 | L | - |
| 3 | P | - |

| | |
|-----------------|-----------------------------|
| Connector No. | E38 |
| Connector Name | STOP LAMP SWITCH (WITH A/T) |
| Connector Color | WHITE |



| Terminal No. | Color of Wire | Signal Name |
|--------------|---------------|-------------|
| 1 | R/B | - |
| 2 | Y | - |

| | |
|-----------------|--------------|
| Connector No. | E26 |
| Connector Name | WIRE TO WIRE |
| Connector Color | WHITE |

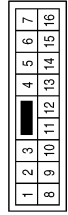

| Terminal No. | Color of Wire | Signal Name |
|--------------|---------------|-------------|
| 8 | SB | - |
| 10 | P | - |
| 11 | L | - |

| | |
|-----------------|--------------------------|
| Connector No. | E21 |
| Connector Name | BRAKE FLUID LEVEL SWITCH |
| Connector Color | GRAY |



| Terminal No. | Color of Wire | Signal Name |
|--------------|---------------|-------------|
| 1 | SB | - |
| 2 | B | - |

ABN1A1.877GB

COMBINATION METER

< ECU DIAGNOSIS >

| | |
|-----------------|--------------|
| Connector No. | E41 |
| Connector Name | WIRE TO WIRE |
| Connector Color | BLACK |

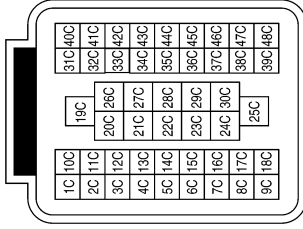

| Terminal No. | Color of Wire | Signal Name |
|--------------|---------------|-------------|
| 13C | BR | - |
| 14C | B/Y | - |

| | |
|-----------------|--------------|
| Connector No. | E40 |
| Connector Name | WIRE TO WIRE |
| Connector Color | GRAY |

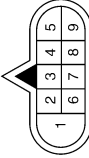

| Terminal No. | Color of Wire | Signal Name |
|--------------|---------------|-------------|
| 5 | GR | - |
| 8 | P | - |

| | |
|-----------------|-----------------------------|
| Connector No. | E38 |
| Connector Name | STOP LAMP SWITCH (WITH M/T) |
| Connector Color | BLACK |



| Terminal No. | Color of Wire | Signal Name |
|--------------|---------------|-------------|
| 1 | R/B | - |
| 2 | Y | - |

| | |
|-----------------|--|
| Connector No. | E124 |
| Connector Name | IPDM E/R (INTELLIGENT POWER DISTRIBUTION MODULE ENGINE ROOM) |
| Connector Color | BLACK |



| Terminal No. | Color of Wire | Signal Name |
|--------------|---------------|-------------|
| 59 | B | GND (POWER) |

| | |
|-----------------|--|
| Connector No. | E122 |
| Connector Name | IPDM E/R (INTELLIGENT POWER DISTRIBUTION MODULE ENGINE ROOM) |
| Connector Color | WHITE |

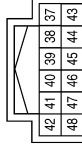

| Terminal No. | Color of Wire | Signal Name |
|--------------|---------------|-----------------|
| 38 | B | GND (SIGNAL) |
| 39 | L | CAN-H |
| 40 | P | CAN-L |
| 42 | GR | OIL PRESSURE SW |

| | |
|-----------------|---------------------------|
| Connector No. | E106 |
| Connector Name | WASHER FLUID LEVEL SWITCH |
| Connector Color | BROWN |



| Terminal No. | Color of Wire | Signal Name |
|--------------|---------------|-------------|
| 1 | L | - |
| 2 | B | - |

ABN1A1878GB

A B C D E F G H I J K L M N O P



COMBINATION METER

< ECU DIAGNOSIS >

| | |
|-----------------|--|
| Connector No. | E125 |
| Connector Name | ABS ACTUATOR AND ELECTRIC UNIT (CONTROL UNIT) (WITH VDC) |
| Connector Color | BLACK |



| | | | | | | | | | | | | | | | |
|----|----|----|----|----|----|----|----|----|----|----|----|----|----|----|----|
| 1 | 2 | 3 | 4 | 5 | 6 | 7 | 8 | 9 | 10 | 11 | 12 | 13 | 14 | 15 | 16 |
| 17 | 18 | 19 | 20 | 21 | 22 | 23 | 24 | 25 | 26 | 27 | 28 | 29 | 30 | 31 | |
| 32 | 33 | 34 | 35 | 36 | 37 | 38 | 39 | 40 | 41 | 42 | 43 | 44 | 45 | 46 | 47 |

| Terminal No. | Color of Wire | Signal Name |
|--------------|---------------|-------------|
| 12 | L | CAN-H |
| 13 | P | CAN-L |

| | |
|-----------------|---|
| Connector No. | E125 |
| Connector Name | ABS ACTUATOR AND ELECTRIC UNIT (CONTROL UNIT) (WITHOUT VDC) |
| Connector Color | BLACK |



| | | | | | | | | | | | | | | | |
|----|----|----|----|----|----|----|----|----|----|----|----|----|----|----|----|
| 1 | 2 | 3 | 4 | 5 | 6 | 7 | 8 | 9 | 10 | 11 | 12 | 13 | 14 | 15 | 16 |
| 17 | 18 | 19 | 20 | 21 | 22 | 23 | 24 | 25 | 26 | 27 | 28 | 29 | 30 | 31 | |
| 32 | 33 | 34 | 35 | 36 | 37 | 38 | 39 | 40 | 41 | 42 | 43 | 44 | 45 | 46 | 47 |

| Terminal No. | Color of Wire | Signal Name |
|--------------|---------------|-------------|
| 11 | L | CAN-H |
| 15 | P | CAN-L |

| | |
|-----------------|------------------|
| Connector No. | E160 |
| Connector Name | FUSE BLOCK (J/B) |
| Connector Color | WHITE |



| | | | | | | | | |
|-----|-----|-----|-----|-----|-----|-----|-----|-----|
| 92 | 93 | 94 | 95 | 96 | 97 | 98 | 99 | 100 |
| 101 | 102 | 103 | 104 | 105 | 106 | 107 | 108 | 109 |

| Terminal No. | Color of Wire | Signal Name |
|--------------|---------------|-------------|
| 8Q | R/B | - |

| Terminal No. | Color of Wire | Signal Name |
|--------------|---------------|-------------|
| 45G | B | - |
| 51G | P | - |
| 52G | L | - |
| 66G | B/Y | - |
| 67G | BR | - |
| 68G | LG | - |
| 69G | P | - |
| 70G | L | - |

| | |
|-----------------|--------------|
| Connector No. | E152 |
| Connector Name | WIRE TO WIRE |
| Connector Color | WHITE |

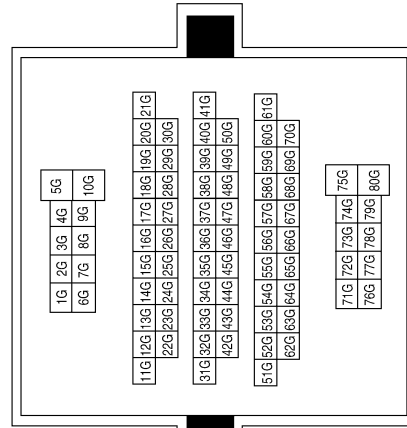

ABN1A1.879GB

COMBINATION METER

< ECU DIAGNOSIS >

| | |
|-----------------|---------------------|
| Connector No. | E208 |
| Connector Name | OIL PRESSURE SWITCH |
| Connector Color | GRAY |



| Terminal No. | Color of Wire | Signal Name |
|--------------|---------------|-------------|
| 1 | GR | - |

| | |
|-----------------|-----------|
| Connector No. | E205 |
| Connector Name | GENERATOR |
| Connector Color | BLACK |



| Terminal No. | Color of Wire | Signal Name |
|--------------|---------------|-------------|
| 2 | P | L |

| | |
|-----------------|--------------|
| Connector No. | E201 |
| Connector Name | WIRE TO WIRE |
| Connector Color | GRAY |



| Terminal No. | Color of Wire | Signal Name |
|--------------|---------------|-------------|
| 5 | GR | - |
| 8 | P | - |

| | |
|-----------------|--------------|
| Connector No. | F14 |
| Connector Name | WIRE TO WIRE |
| Connector Color | WHITE |

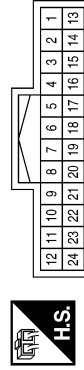

| Terminal No. | Color of Wire | Signal Name |
|--------------|---------------|-------------|
| 2 | L | - |
| 3 | P | - |
| 21 | R | - |

| | |
|-----------------|--------------|
| Connector No. | F9 |
| Connector Name | A/T ASSEMBLY |
| Connector Color | GREEN |



| Terminal No. | Color of Wire | Signal Name |
|--------------|---------------|-------------|
| 3 | L | - |
| 8 | P | - |
| 9 | R | - |

| | |
|-----------------|-----------|
| Connector No. | E209 |
| Connector Name | GENERATOR |
| Connector Color | - |



| Terminal No. | Color of Wire | Signal Name |
|--------------|---------------|-------------|
| 5 | B | E |

ABN1A1880GB

A
B
C
D
E
F
G
H
I
J
K
L
M
N
O
P

MWI

COMBINATION METER

< ECU DIAGNOSIS >

| | |
|-----------------|--------------|
| Connector No. | C1 |
| Connector Name | WIRE TO WIRE |
| Connector Color | BLACK |

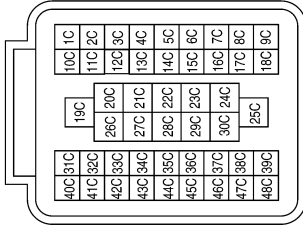

| Terminal No. | Color of Wire | Signal Name |
|--------------|---------------|-------------|
| 13C | BR | - |
| 14C | B/Y | - |

| | |
|-----------------|-----------------------------------|
| Connector No. | F502 |
| Connector Name | TCM (TRANSMISSION CONTROL MODULE) |
| Connector Color | GRAY |

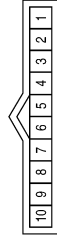

| Terminal No. | Color of Wire | Signal Name |
|--------------|---------------|-------------|
| 1 | BR | CAN-H |
| 2 | L/Y | CAN-L |
| 8 | G | STARTER-RLY |

| | |
|-----------------|--------------|
| Connector No. | F32 |
| Connector Name | WIRE TO WIRE |
| Connector Color | WHITE |

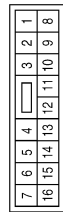

| Terminal No. | Color of Wire | Signal Name |
|--------------|---------------|-------------|
| 2 | L | - |
| 3 | P | - |

| | |
|-----------------|-------------------------------|
| Connector No. | B9 |
| Connector Name | AIR BAG DIAGNOSIS SENSOR UNIT |
| Connector Color | YELLOW |

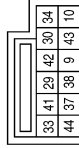

| Terminal No. | Color of Wire | Signal Name |
|--------------|---------------|--------------------|
| 41 | O | LH BUCKLE SW INPUT |

| | |
|-----------------|----------------------|
| Connector No. | B8 |
| Connector Name | FRONT DOOR SWITCH LH |
| Connector Color | WHITE |



| Terminal No. | Color of Wire | Signal Name |
|--------------|---------------|-------------|
| 2 | GR | - |

| | |
|-----------------|--------------------------------------|
| Connector No. | C5 |
| Connector Name | FUEL LEVEL SENSOR UNIT AND FUEL PUMP |
| Connector Color | GRAY |

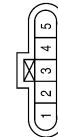

| Terminal No. | Color of Wire | Signal Name |
|--------------|---------------|-------------|
| 2 | BR | - |
| 5 | B/Y | - |

COMBINATION METER

< ECU DIAGNOSIS >

| | |
|-----------------|--------------|
| Connector No. | B48 |
| Connector Name | WIRE TO WIRE |
| Connector Color | WHITE |

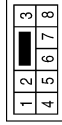

| Terminal No. | Color of Wire | Signal Name |
|--------------|---------------|-------------|
| 1 | Y | - |

| | |
|-----------------|---------------------|
| Connector No. | B18 |
| Connector Name | REAR DOOR SWITCH LH |
| Connector Color | WHITE |

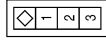

| Terminal No. | Color of Wire | Signal Name |
|--------------|---------------|-------------|
| 2 | P | - |

| | |
|-----------------|----------------------------|
| Connector No. | B12 |
| Connector Name | SEAT BELT BUCKLE SWITCH LH |
| Connector Color | WHITE |

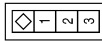

| Terminal No. | Color of Wire | Signal Name |
|--------------|---------------|-------------|
| 1 | O | - |
| 2 | B | - |

| | |
|-----------------|----------------------|
| Connector No. | B84 |
| Connector Name | PARKING BRAKE SWITCH |
| Connector Color | BLACK |



| Terminal No. | Color of Wire | Signal Name |
|--------------|---------------|-------------|
| 1 | G | - |

| Terminal No. | Color of Wire | Signal Name |
|--------------|---------------|-------------|
| 57J | Y | - |
| 60J | P | - |
| 61J | GR | - |
| 68J | G | - |
| 70J | V | - |

| | |
|-----------------|--------------|
| Connector No. | B69 |
| Connector Name | WIRE TO WIRE |
| Connector Color | WHITE |

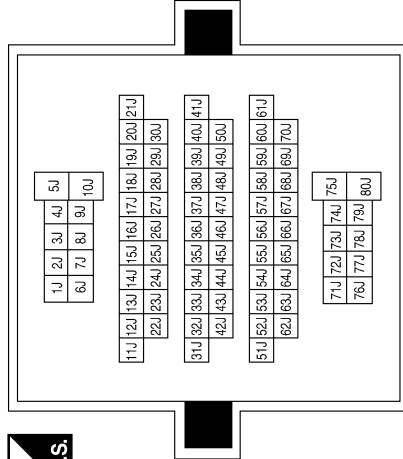

ABN1A1882GB

A
B
C
D
E
F
G
H
I
J
K
L
M
MWI
O
P

COMBINATION METER

< ECU DIAGNOSIS >

| | |
|-----------------|-------------------------------|
| Connector No. | B113 |
| Connector Name | AIR BAG DIAGNOSIS SENSOR UNIT |
| Connector Color | YELLOW |

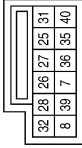

| | | | | | |
|--------------|----|---------------|---|-------------|--------------------|
| Terminal No. | 25 | Color of Wire | L | Signal Name | RH BUCKLE SW INPUT |
|--------------|----|---------------|---|-------------|--------------------|

| | |
|-----------------|----------------------------|
| Connector No. | B110 |
| Connector Name | SEAT BELT BUCKLE SWITCH RH |
| Connector Color | WHITE |

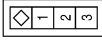

| | | | | | |
|--------------|---|---------------|---|-------------|---|
| Terminal No. | 1 | Color of Wire | L | Signal Name | - |
| 2 | B | - | - | | |

| | |
|-----------------|----------------------|
| Connector No. | B108 |
| Connector Name | FRONT DOOR SWITCH RH |
| Connector Color | WHITE |

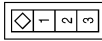

| | | | | | |
|--------------|---|---------------|----|-------------|---|
| Terminal No. | 2 | Color of Wire | LG | Signal Name | - |
|--------------|---|---------------|----|-------------|---|

| | |
|-----------------|--------------|
| Connector No. | D402 |
| Connector Name | WIRE TO WIRE |
| Connector Color | WHITE |



| | | | | | |
|--------------|---|---------------|---|-------------|---|
| Terminal No. | 1 | Color of Wire | Y | Signal Name | - |
|--------------|---|---------------|---|-------------|---|

| | |
|-----------------|--------------|
| Connector No. | B162 |
| Connector Name | WIRE TO WIRE |
| Connector Color | WHITE |

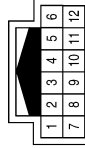

| | | | | | |
|--------------|---|---------------|----|-------------|---|
| Terminal No. | 7 | Color of Wire | LG | Signal Name | - |
| 8 | L | - | - | | |

| | |
|-----------------|---------------------|
| Connector No. | B116 |
| Connector Name | REAR DOOR SWITCH RH |
| Connector Color | WHITE |









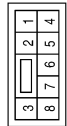

| | | | | | |
|--------------|---|---------------|---|-------------|---|
| Terminal No. | 2 | Color of Wire | L | Signal Name | - |
|--------------|---|---------------|---|-------------|---|

ABN1A1883GB

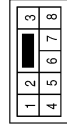
COMBINATION METER

< ECU DIAGNOSIS >

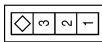
| | | | | | | | | |
|---|--------------|-----------------|---|-----------------|--------------|---|--|--|
| Connector No. | D405 | Connector No. | D409 | Connector No. | D501 | | | |
| Connector Name | WIRE TO WIRE | Connector Name | WIRE TO WIRE | Connector Name | WIRE TO WIRE | | | |
| Connector Color | WHITE | Connector Color | WHITE | Connector Color | WHITE | | | |
|   | | |   | | |   | | |
| Terminal No. | 1 | Terminal No. | 2 | Terminal No. | 1 | | | |
| Color of Wire | Y | Color of Wire | B | Color of Wire | Y | | | |
| Signal Name | - | Signal Name | - | Signal Name | - | | | |
| Terminal No. | 6 | Terminal No. | | Terminal No. | 6 | | | |
| Color of Wire | B | Color of Wire | | Color of Wire | B | | | |
| Signal Name | - | Signal Name | | Signal Name | - | | | |

| | | | |
|---|------------------|---|--------------|
| Connector No. | D502 | Connector No. | D650 |
| Connector Name | BACK DOOR SWITCH | Connector Name | WIRE TO WIRE |
| Connector Color | WHITE | Connector Color | WHITE |
|   | |   | |
| Terminal No. | 1 | Terminal No. | 2 |
| Color of Wire | B | Color of Wire | B |
| Signal Name | - | Color of Wire | |
| Terminal No. | 3 | Terminal No. | |
| Color of Wire | Y | Color of Wire | |
| Signal Name | - | Signal Name | |

Fail Safe

The combination meter performs a fail-safe operation for the functions listed below when communication is lost.

ABNIA1884GB

INFOID:0000000005281784

A
B
C
D
E
F
G
H
I
J
K
L
M
N
O
P

MWI

COMBINATION METER

< ECU DIAGNOSIS >

| Function | | Specifications |
|----------------------------------|---|--|
| Speedometer | | Zero indication. |
| Tachometer | | |
| Fuel gauge | | |
| Engine coolant temperature gauge | | |
| Engine oil pressure gauge | | |
| Voltage gauge | | |
| Illumination control | Meter illumination | Change to nighttime mode when communication is lost. |
| Segment LCD | Odometer | Freeze current indication. |
| | A/T position | Display turns off. |
| Buzzer | | Buzzer turns off. |
| Warning lamp/indicator lamp | ABS warning lamp | Lamp turns on when communication is lost. |
| | Brake warning lamp | |
| | VDC OFF indicator lamp | |
| | SLIP indicator lamp | |
| | Malfunction indicator lamp | |
| | AT oil temp warning lamp | Lamp turns off when communication is lost. |
| | Low washer fluid warning lamp | |
| | Door ajar warning lamp | |
| | CRUISE indicator lamp | |
| | SET indicator lamp | |
| | O/D OFF indicator lamp | |
| | Oil pressure warning lamp | |
| | Air bag warning lamp | |
| | High beam indicator | |
| | Turn signal indicator lamp | |
| | Speed warning lamp | Lamp turns off when disconnected. |
| | Seat belt warning lamp | |
| | Charge warning lamp | |
| | Security indicator lamp | |
| | 4WD indicator lamp | |
| ATP indicator lamp | | |
| DIFF LOCK indicator lamp | Lamp will flash every second for 1 minute and then stay on continuously thereafter. | |
| Low tire pressure warning lamp | | |

COMBINATION METER

< ECU DIAGNOSIS >

DTC Index

INFOID:000000005281785

| CONSULT-III display | Malfunction | Reference page |
|----------------------------------|---|------------------------|
| CAN COMM CIRC [U1000] | Malfunction is detected in CAN communication. CAUTION: Even when there is no malfunction on CAN communication system, malfunction may be misinterpreted when battery has low voltage (when maintaining 7 - 8 V for about 2 seconds) or 10A fuse [No. 19, located in the fuse block (J/B)] is disconnected. | MWI-25 |
| VEHICLE SPEED CIRC [B2205] | Malfunction is detected when an erroneous speed signal is input. CAUTION: Even when there is no malfunction on speed signal system, malfunction may be misinterpreted when battery has low voltage (when maintaining 7 - 8 V for about 2 seconds). | MWI-26 |

NOTE:

“TIME” indicates the following.

- 0: Indicates that a malfunction is detected at present.
- 1-63: Indicates that a malfunction was detected in the past. (Displays number of ignition switch OFF → ON cycles after malfunction is detected. Self-diagnosis result is erased when “63” is exceeded.)

A
B
C
D
E
F
G
H
I
J
K
L
M
O
P

MWI

BCM (BODY CONTROL MODULE)

< ECU DIAGNOSIS >

BCM (BODY CONTROL MODULE)

Reference Value

INFOID:000000005712958

VALUES ON THE DIAGNOSIS TOOL

| Monitor Item | Condition | Value/Status |
|----------------|---|--------------|
| IGN ON SW | Ignition switch OFF or ACC | OFF |
| | Ignition switch ON | ON |
| KEY ON SW | Mechanical key is removed from key cylinder | OFF |
| | Mechanical key is inserted to key cylinder | ON |
| CDL LOCK SW | Door lock/unlock switch does not operate | OFF |
| | Press door lock/unlock switch to the lock side | ON |
| CDL UNLOCK SW | Door lock/unlock switch does not operate | OFF |
| | Press door lock/unlock switch to the unlock side | ON |
| DOOR SW-DR | Driver's door closed | OFF |
| | Driver's door opened | ON |
| DOOR SW-AS | Passenger door closed | OFF |
| | Passenger door opened | ON |
| DOOR SW-RR | Rear RH door closed | OFF |
| | Rear RH door opened | ON |
| DOOR SW-RL | Rear LH door closed | OFF |
| | Rear LH door opened | ON |
| BACK DOOR SW | Back door closed | OFF |
| | Back door opened | ON |
| KEY CYL LK-SW | Other than driver door key cylinder LOCK position | OFF |
| | Driver door key cylinder LOCK position | ON |
| KEY CYL UN-SW | Other than driver door key cylinder UNLOCK position | OFF |
| | Driver door key cylinder UNLOCK position | ON |
| KEYLESS LOCK | "LOCK" button of key fob is not pressed | OFF |
| | "LOCK" button of key fob is pressed | ON |
| KEYLESS UNLOCK | "UNLOCK" button of key fob is not pressed | OFF |
| | "UNLOCK" button of key fob is pressed | ON |
| ACC ON SW | Ignition switch OFF | OFF |
| | Ignition switch ACC or ON | ON |
| REAR DEF SW | Rear window defogger switch OFF | OFF |
| | Rear window defogger switch ON | ON |
| LIGHT SW 1ST | Lighting switch OFF | OFF |
| | Lighting switch 1ST | ON |
| BUCKLE SW | The seat belt (driver side) is unfastened. [Seat belt switch (driver side) OFF] | OFF |
| | The seat belt (driver side) is fastened. [Seat belt switch (driver side) ON] | ON |
| KEYLESS PANIC | PANIC button of key fob is not pressed | OFF |
| | PANIC button of key fob is pressed | ON |

BCM (BODY CONTROL MODULE)

< ECU DIAGNOSIS >

| Monitor Item | Condition | Value/Status | |
|----------------|--|-----------------------------------|-----|
| RKE LCK-UNLCK | LOCK/UNLOCK button of key fob is not pressed and held simultaneously | OFF | A |
| | LOCK/UNLOCK button of key fob is pressed and held simultaneously | ON | B |
| RKE KEEP UNLK | UNLOCK button of key fob is not pressed | OFF | C |
| | UNLOCK button of key fob is pressed and held | ON | |
| HI BEAM SW | Lighting switch OFF | OFF | D |
| | Lighting switch HI | ON | |
| HEAD LAMP SW 1 | Lighting switch OFF | OFF | E |
| | Lighting switch 2ND | ON | |
| HEAD LAMP SW 2 | Lighting switch OFF | OFF | F |
| | Lighting switch 2ND | ON | |
| PASSING SW | Other than lighting switch PASS | OFF | G |
| | Lighting switch PASS | ON | |
| FR FOG SW | Front fog lamp switch OFF | OFF | H |
| | Front fog lamp switch ON | ON | |
| TURN SIGNAL R | Turn signal switch OFF | OFF | I |
| | Turn signal switch RH | ON | |
| TURN SIGNAL L | Turn signal switch OFF | OFF | J |
| | Turn signal switch LH | ON | |
| CARGO LAMP SW | Cargo lamp switch OFF | OFF | K |
| | Cargo lamp switch ON | ON | |
| IGN SW CAN | Ignition switch OFF or ACC | OFF | L |
| | Ignition switch ON | ON | |
| FR WIPER HI | Front wiper switch OFF | OFF | M |
| | Front wiper switch HI | ON | |
| FR WIPER LOW | Front wiper switch OFF | OFF | MWI |
| | Front wiper switch LO | ON | |
| FR WIPER INT | Front wiper switch OFF | OFF | O |
| | Front wiper switch INT | ON | |
| FR WASHER SW | Front washer switch OFF | OFF | P |
| | Front washer switch ON | ON | |
| INT VOLUME | Wiper intermittent dial is in a dial position 1 - 7 | 1 - 7 | |
| FR WIPER STOP | Any position other than front wiper stop position | OFF | |
| | Front wiper stop position | ON | |
| VEHICLE SPEED | While driving | Equivalent to speedometer reading | |
| RR WIPER ON | Rear wiper switch OFF | OFF | O |
| | Rear wiper switch ON | ON | |
| RR WIPER INT | Rear wiper switch OFF | OFF | P |
| | Rear wiper switch INT | ON | |
| RR WASHER SW | Rear washer switch OFF | OFF | |
| | Rear washer switch ON | ON | |
| RR WIPER STOP | Any position other than rear wiper stop position | OFF | |
| | Rear wiper stop position | ON | |

BCM (BODY CONTROL MODULE)

< ECU DIAGNOSIS >

| Monitor Item | Condition | Value/Status |
|--------------|---|-------------------------------|
| HAZARD SW | Hazard switch OFF | OFF |
| | Hazard switch ON | ON |
| BRAKE SW | Brake pedal is not depressed | OFF |
| | Brake pedal is depressed | ON |
| FAN ON SIG | Blower fan motor switch OFF | OFF |
| | Blower fan motor switch ON (other than OFF) | ON |
| AIR COND SW | Compressor ON is not requested from auto amp. (A/C indicator OFF, blower fan motor switch OFF or etc.) | OFF |
| | Compressor ON is requested from auto amp. (A/C indicator ON and blower fan motor switch ON). | ON |
| OIL PRESS SW | <ul style="list-style-type: none"> • Ignition switch OFF or ACC • Engine running | OFF |
| | Ignition switch ON | ON |
| AIR PRESS FL | Ignition switch ON (Only when the signal from the transmitter is received) | Air pressure of front LH tire |
| AIR PRESS FR | Ignition switch ON (Only when the signal from the transmitter is received) | Air pressure of front RH tire |
| AIR PRESS RR | Ignition switch ON (Only when the signal from the transmitter is received) | Air pressure of rear RH tire |
| AIR PRESS RL | Ignition switch ON (Only when the signal from the transmitter is received) | Air pressure of rear LH tire |
| ID REGST FL1 | ID of front LH tire transmitter is registered | DONE |
| | ID of front LH tire transmitter is not registered | YET |
| ID REGST FR1 | ID of front RH tire transmitter is registered | DONE |
| | ID of front RH tire transmitter is not registered | YET |
| ID REGST RR1 | ID of rear RH tire transmitter is registered | DONE |
| | ID of rear RH tire transmitter is not registered | YET |
| ID REGST RL1 | ID of rear LH tire transmitter is registered | DONE |
| | ID of rear LH tire transmitter is not registered | YET |
| WARNING LAMP | Tire pressure indicator OFF | OFF |
| | Tire pressure indicator ON | ON |
| BUZZER | Tire pressure warning alarm is not sounding | OFF |
| | Tire pressure warning alarm is sounding | ON |

BCM (BODY CONTROL MODULE)

< ECU DIAGNOSIS >

Terminal Layout

INFOID:000000005712959

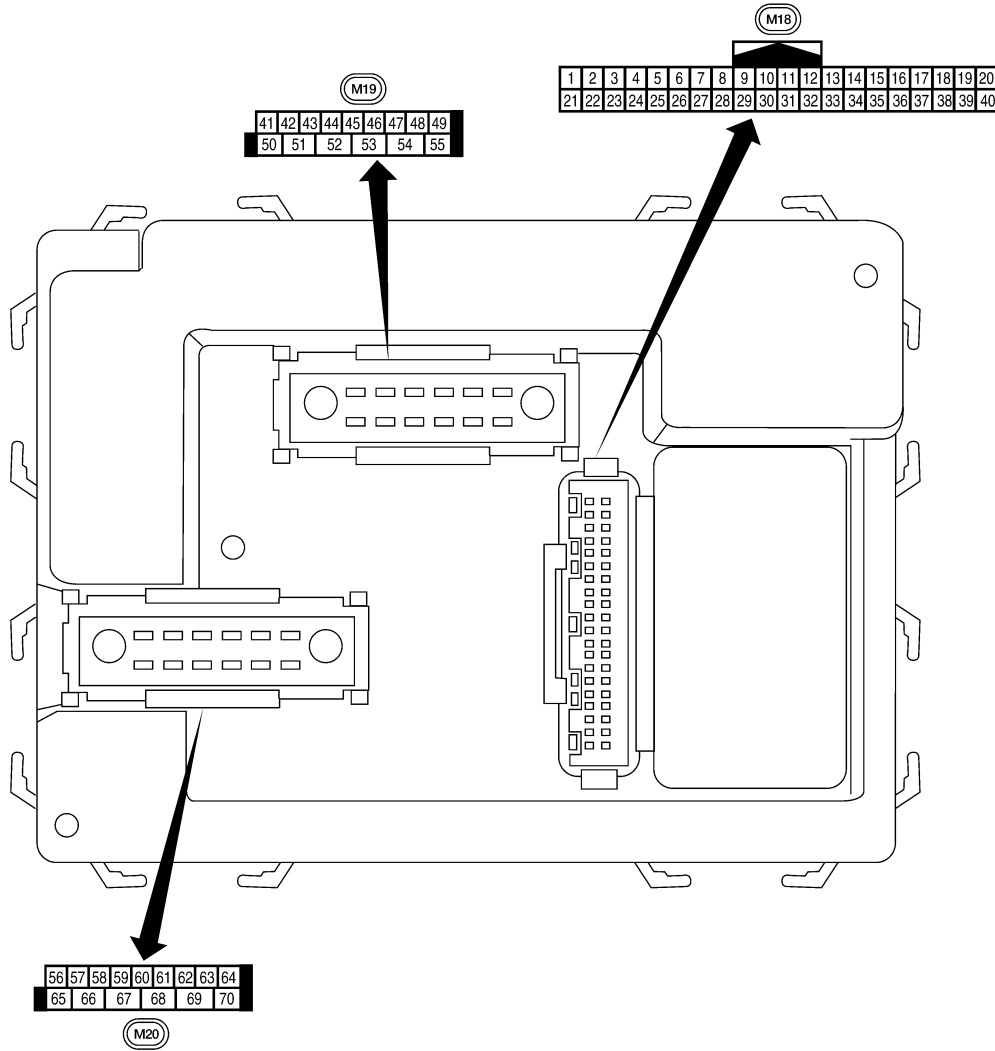

A
B
C
D
E
F
G
H
I
J
K
L
M

MWI



Physical Values

LIIA2443E

INFOID:000000005712960

BCM (BODY CONTROL MODULE)

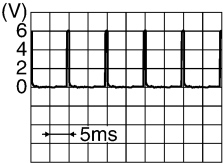
< ECU DIAGNOSIS >

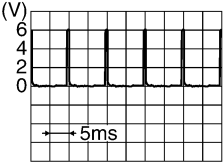
| Terminal | Wire color | Signal name | Signal input/output | Measuring condition | | Reference value or waveform (Approx.) |
|----------|------------|--|---------------------|---------------------|--|--|
| | | | | Ignition switch | Operation or condition | |
| 1 | BR | Ignition keyhole illumination | Output | OFF | Door is locked (SW OFF) | Battery voltage |
| | | | | | Door is unlocked (SW ON) | 0V |
| 2 | P | Combination switch input 5 | Input | ON | Lighting, turn, wiper OFF Wiper dial position 4 |  SKIA5291E |
| 3 | SB | Combination switch input 4 | Input | ON | Lighting, turn, wiper OFF Wiper dial position 4 |  SKIA5292E |
| 4 | V | Combination switch input 3 | Input | ON | Lighting, turn, wiper OFF Wiper dial position 4 |  SKIA5291E |
| 5 | L | Combination switch input 2 | Input | ON | Lighting, turn, wiper OFF Wiper dial position 4 |  SKIA5292E |
| 6 | R | Combination switch input 1 | | | | |
| 7 | GR | Front door lock assembly LH (key cylinder switch) and back door key cylinder switch (unlock) | Input | OFF | ON (open, 2nd turn) | Momentary 1.5V |
| | | | | | OFF (closed) | 0V |
| 8 | SB | Front door lock assembly LH (key cylinder switch) and back door key cylinder switch (lock) | Input | OFF | ON (open) | Momentary 1.5V |
| | | | | | OFF (closed) | 0V |
| 9 | Y | Rear window defogger switch | Input | ON | Rear window defogger switch ON | 0V |
| | | | | | Rear window defogger switch OFF | 5V |
| 11 | G/B | Ignition switch (ACC or ON) | Input | ACC or ON | Ignition switch ACC or ON | Battery voltage |
| 12 | LG | Front door switch RH | Input | OFF | ON (open) | 0V |
| | | | | | OFF (closed) | Battery voltage |

BCM (BODY CONTROL MODULE)

< ECU DIAGNOSIS >

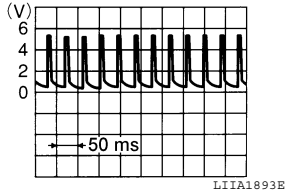
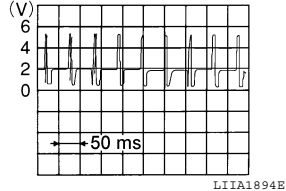
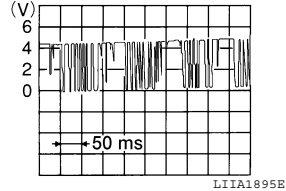
| Terminal | Wire color | Signal name | Signal input/output | Measuring condition | | Reference value or waveform (Approx.) |
|----------|------------|---|---------------------|---------------------|---|--|
| | | | | Ignition switch | Operation or condition | |
| 13 | L | Rear door switch RH | Input | OFF | ON (open) | 0V |
| | | | | | OFF (closed) | Battery voltage |
| 15 | W | Tire pressure warning check connector | Input | OFF | — | 5V |
| 18 | BR | Remote keyless entry receiver and optical sensor (ground) | Output | OFF | — | 0V |
| 19 | V | Remote keyless entry receiver (power supply) | Output | OFF | Ignition switch OFF |  |
| 20 | G | Remote keyless entry receiver (signal) | Input | OFF | Stand-by (keyfob buttons released) |  |
| | | | | | When remote keyless entry receiver receives signal from keyfob (keyfob buttons pressed) |  |
| 21 | GR | Immobilizer antenna signal (clock) | Input | OFF → ON | Ignition switch (OFF → ON) | Just after turning ignition switch ON: Pointer of tester should move for approx. 1 second, then return to battery voltage. |
| 23 | G | Security indicator lamp | Output | OFF | Goes OFF → illuminates (Every 2.4 seconds) | Battery voltage → 0V |
| 25 | BR | NATS antenna amp. | Input | OFF → ON | Ignition switch (OFF → ON) | Just after turning ignition switch ON: Pointer of tester should move for approx. 1 second, then return to battery voltage. |
| 27 | W | Compressor ON signal | Input | ON | A/C switch OFF | 5V |
| | | | | | A/C switch ON | 0V |
| 28 | R | Front blower monitor | Input | ON | Front blower motor OFF | Battery voltage |
| | | | | | Front blower motor ON | 0V |
| 29 | G | Hazard switch | Input | OFF | ON | 0V |
| | | | | | OFF | 5V |

A
B
C
D
E
F
G
H
I
J
K
L
M
O
P

MWI

BCM (BODY CONTROL MODULE)

< ECU DIAGNOSIS >

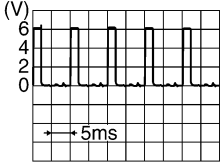
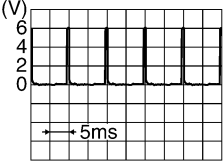
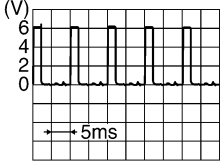
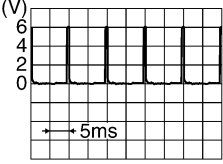
| Terminal | Wire color | Signal name | Signal input/output | Measuring condition | | Reference value or waveform (Approx.) |
|----------|------------|----------------------------------|---------------------|---------------------|--|---|
| | | | | Ignition switch | Operation or condition | |
| 32 | O | Combination switch output 5 | Output | ON | Lighting, turn, wiper OFF Wiper dial position 4 |  <p style="text-align: right; font-size: small;">SKIA5291E</p> |
| 33 | GR | Combination switch output 4 | Output | ON | Lighting, turn, wiper OFF Wiper dial position 4 |  <p style="text-align: right; font-size: small;">SKIA5292E</p> |
| 34 | G | Combination switch output 3 | Output | ON | Lighting, turn, wiper OFF Wiper dial position 4 |  <p style="text-align: right; font-size: small;">SKIA5291E</p> |
| 35 | BR | Combination switch output 2 | Output | ON | Lighting, turn, wiper OFF Wiper dial position 4 |  <p style="text-align: right; font-size: small;">SKIA5292E</p> |
| 36 | LG | Combination switch output 1 | | | | |
| 37 | B | Key switch and key lock solenoid | Input | OFF | Key inserted | Battery voltage |
| | | | | | Key inserted | 0V |
| 38 | W/R | Ignition switch (ON) | Input | ON | — | Battery voltage |
| 39 | L | CAN-H | — | — | — | — |
| 40 | P | CAN-L | — | — | — | — |
| 43 | Y | Back door switch | Input | OFF | ON (open) | 0V |
| | | | | | OFF (closed) | Battery voltage |
| 44 | O | Rear wiper auto stop switch | Input | ON | Rise up position (rear wiper arm on stopper) | 0V |
| | | | | | A Position (full clockwise stop position) | Battery voltage |
| | | | | | Forward sweep (counterclockwise direction) | Fluctuating |
| | | | | | B Position (full counterclockwise stop position) | 0V |
| | | | | | Reverse sweep (clockwise direction) | Fluctuating |
| 45 | V | Lock switch | Input | OFF | ON (lock) | 0V |
| | | | | | OFF | Battery voltage |

BCM (BODY CONTROL MODULE)

< ECU DIAGNOSIS >

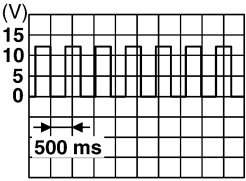
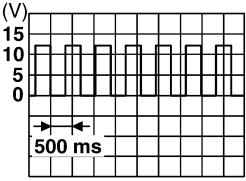
| Terminal | Wire color | Signal name | Signal input/output | Measuring condition | | Reference value or waveform (Approx.) | |
|----------|------------|--|---------------------|---------------------|--|---|----|
| | | | | Ignition switch | Operation or condition | | |
| 46 | LG | Unlock switch | Input | OFF | ON (unlock) | 0V | |
| | | | | | OFF | Battery voltage | |
| 47 | GR | Front door switch LH | Input | OFF | ON (open) | 0V | |
| | | | | | OFF (closed) | Battery voltage | |
| 48 | P | Rear door switch LH | Input | OFF | ON (open) | 0V | |
| | | | | | OFF (closed) | Battery voltage | |
| 49 | L | Cargo lamp | Output | OFF | Any door open (ON) | 0V | |
| | | | | | All doors closed (OFF) | Battery voltage | |
| 55 | W | Rear wiper output circuit 1 | Output | ON | OFF | 0 | |
| | | | | | ON | Battery voltage | |
| 56 | R/Y | Battery saver output | Output | OFF | 30 minutes after ignition switch is turned OFF | 0V | |
| | | | | ON | — | Battery voltage | |
| 57 | R/Y | Battery power supply | Input | OFF | — | Battery voltage | |
| 59 | GR | Front door lock assembly LH actuator (unlock) | Output | OFF | OFF (neutral) | 0V | |
| | | | | | ON (unlock) | Battery voltage | |
| 60 | LG | Turn signal (left) | Output | ON | Turn left ON |  <small>SKIA3009J</small> | |
| 61 | G | Turn signal (right) | Output | ON | Turn right ON |  <small>SKIA3009J</small> | |
| 63 | BR | Interior room/map lamp | Output | OFF | Any door switch | ON (open) | 0V |
| | | | | | OFF (closed) | Battery voltage | |
| 65 | V | All door lock actuators (lock) | Output | OFF | OFF (neutral) | 0V | |
| | | | | | ON (lock) | Battery voltage | |
| 66 | L | Front door lock actuator RH, rear door lock actuators LH/RH and back door lock actuator (unlock) | Output | OFF | OFF (neutral) | 0V | |
| | | | | | ON (unlock) | Battery voltage | |
| 67 | B | Ground | Input | ON | — | 0V | |

A
B
C
D
E
F
G
H
I
J
K
L
M
MWI
O
P

BCM (BODY CONTROL MODULE)

< ECU DIAGNOSIS >

| Terminal | Wire color | Signal name | Signal input/output | Measuring condition | | Reference value or waveform (Approx.) |
|----------|------------|---------------------------------|---------------------|---------------------|---|---------------------------------------|
| | | | | Ignition switch | Operation or condition | |
| 68 | O | Power window power supply (RAP) | Output | — | Ignition switch ON | Battery voltage |
| | | | | | Within 45 seconds after ignition switch OFF | Battery voltage |
| | | | | | More than 45 seconds after ignition switch OFF | 0V |
| | | | | | When front door LH or RH is open or power window timer operates | 0V |
| 70 | W | Battery power supply | Input | OFF | — | Battery voltage |

BCM (BODY CONTROL MODULE)

< ECU DIAGNOSIS >

Wiring Diagram

INFOID:000000005712961

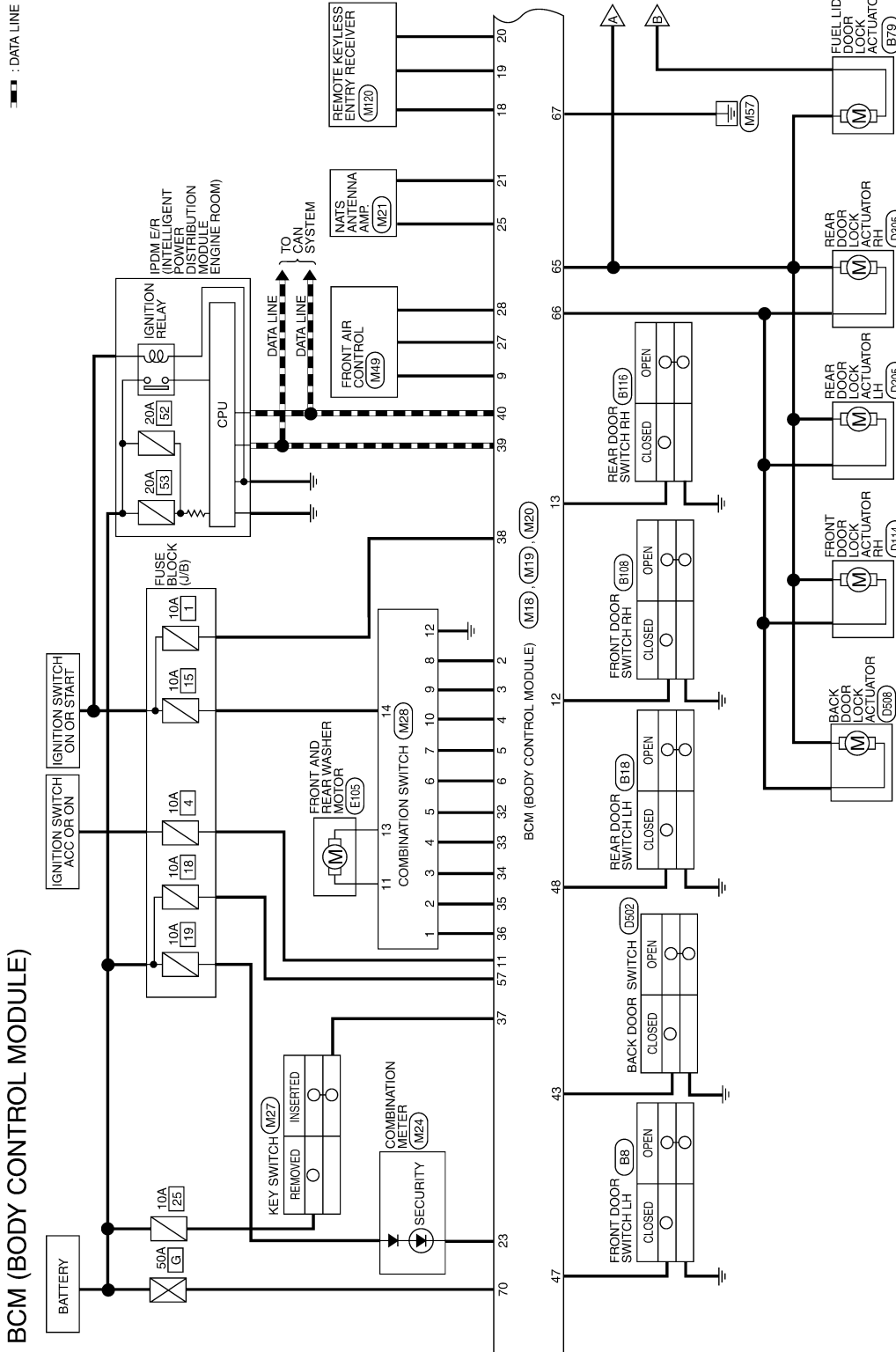

A
B
C
D
E
F
G
H
I
J
K
L
M
N
O
P



BCM (BODY CONTROL MODULE)

< ECU DIAGNOSIS >

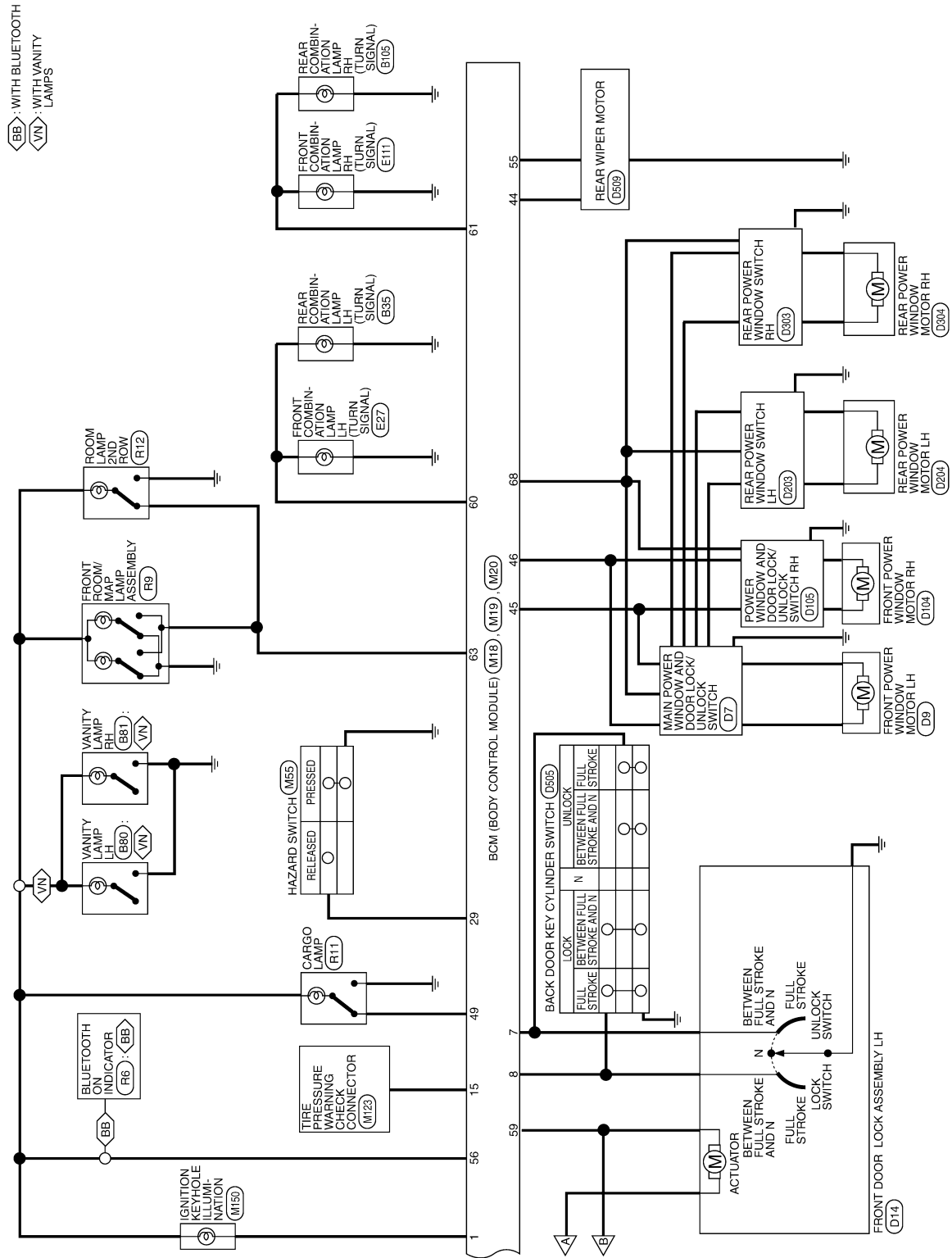

ABMWA0213GB

BCM (BODY CONTROL MODULE)

< ECU DIAGNOSIS >

BCM (BODY CONTROL MODULE) CONNECTORS

| | |
|-----------------|---------------------------|
| Connector No. | M18 |
| Connector Name | BCM (BODY CONTROL MODULE) |
| Connector Color | WHITE |

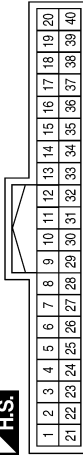

| Terminal No. | Color of Wire | Signal Name |
|--------------|---------------|------------------------|
| 1 | BR | KEY RING OUTPUT |
| 2 | P | INPUT 5 |
| 3 | SB | INPUT 3 |
| 4 | V | INPUT 4 |
| 5 | L | INPUT 2 |
| 6 | R | INPUT 1 |
| 7 | GR | KEY CYLINDER UNLOCK SW |
| 8 | SB | KEY CYLINDER LOCK SW |

| | |
|-----------------|---------------------------|
| Connector No. | M19 |
| Connector Name | BCM (BODY CONTROL MODULE) |
| Connector Color | WHITE |

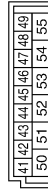

| Terminal No. | Color of Wire | Signal Name |
|--------------|---------------|-------------|
| 41 | - | - |

| Terminal No. | Color of Wire | Signal Name |
|--------------|---------------|-----------------------------------|
| 9 | Y | DEFOGGER SW |
| 10 | - | - |
| 11 | G/B | ACC_SW |
| 12 | LG | DOOR SW (AS) |
| 13 | L | DOOR SW (RR) |
| 14 | - | - |
| 15 | W | TPMS MODE TRIGGER SW |
| 16 | - | - |
| 17 | - | - |
| 18 | BR | KEYLESS & AUTO LIGHT SENSOR GND |
| 19 | V | KEYLESS TUNER POWER SUPPLY OUTPUT |
| 20 | G | KEYLESS TUNER SIGNAL |
| 21 | GR | ANTENNA SIGNAL IMMOBILIZER |
| 22 | - | - |

| Terminal No. | Color of Wire | Signal Name |
|--------------|---------------|----------------------------------|
| 23 | G | SECURITY INDICATOR OUTPUT |
| 24 | - | - |
| 25 | BR | IMMOBILIZER ANTENNA SIG (RX, TX) |
| 26 | - | - |
| 27 | W | AIRCON SW |
| 28 | R | BLOWER FAN SW |
| 29 | G | HAZARD SW |
| 30 | - | - |
| 31 | - | - |
| 32 | O | OUTPUT 5 |
| 33 | GR | OUTPUT 4 |
| 34 | G | OUTPUT 3 |
| 35 | BR | OUTPUT 2 |
| 36 | LG | OUTPUT 1 |
| 37 | B | KEY SW |
| 38 | W/R | IGN SW |
| 39 | L | CAN-H |
| 40 | P | CAN-L |

| Terminal No. | Color of Wire | Signal Name |
|--------------|---------------|--------------------------|
| 42 | - | - |
| 43 | Y | BACK DOOR SW |
| 44 | O | REAR WIPER AUTO STOP SW1 |
| 45 | V | CDL LOCK SW |
| 46 | LG | CDL UNLOCK SW |
| 47 | GR | DOOR SW (DR) |
| 48 | P | DOOR SW (RL) |
| 49 | L | CARGO LAMP OUTPUT |

| Terminal No. | Color of Wire | Signal Name |
|--------------|---------------|---------------------------|
| 50 | - | - |
| 51 | - | - |
| 52 | - | - |
| 53 | - | - |
| 54 | - | - |
| 55 | W | REAR WIPER MOTOR OUTPUT 1 |

ABMIA0641GB

A B C D E F G H I J K L M N O P



BCM (BODY CONTROL MODULE)

< ECU DIAGNOSIS >

| Terminal No. | Color of Wire | Signal Name |
|--------------|---------------|---|
| 61 | G | FLASHER OUTPUT (RIGHT) |
| 62 | - | - |
| 63 | BR | ROOM LAMP OUTPUT |
| 64 | - | - |
| 65 | V | DOOR LOCK OUTPUT (ALL) |
| 66 | L | DOOR UNLOCK OUTPUT (OTHER) |
| 67 | B | GND (POWER) |
| 68 | O | POWER WINDOW POWER SUPPLY OUT (LINKED TO RAP) |
| 69 | - | - |
| 70 | W | BAT (F/L) |

| | |
|-----------------|---------------------------|
| Connector No. | M20 |
| Connector Name | BCM (BODY CONTROL MODULE) |
| Connector Color | BLACK |

| | | | | | | | | |
|----|----|----|----|----|----|----|----|----|
| 56 | 57 | 58 | 59 | 60 | 61 | 62 | 63 | 64 |
| 65 | 66 | 67 | 68 | 69 | 70 | | | |



| Terminal No. | Color of Wire | Signal Name |
|--------------|---------------|-------------------------|
| 56 | V | BATTERY SAVER OUTPUT |
| 57 | R/Y | BAT (FUSE) |
| 58 | - | - |
| 59 | GR | DOOR UNLOCK OUTPUT (DR) |
| 60 | LG | FLASHER OUTPUT (LEFT) |

| Terminal No. | Color of Wire | Signal Name |
|--------------|---------------|-------------------|
| 1 | LG | INPUT 1 |
| 2 | BR | INPUT 2 |
| 3 | G | INPUT 3 |
| 4 | GR | INPUT 4 |
| 5 | O | INPUT 5 |
| 6 | R | OUTPUT 1 |
| 7 | L | OUTPUT 2 |
| 8 | P | OUTPUT 5 |
| 9 | SB | OUTPUT 4 |
| 10 | V | OUTPUT 3 |
| 11 | O | WASH_FR (-)_RR(+) |
| 12 | B | GND |
| 13 | L | WASH_FR (+)_RR(-) |
| 14 | W | ING |

| | |
|-----------------|--------------------|
| Connector No. | M28 |
| Connector Name | COMBINATION SWITCH |
| Connector Color | WHITE |

| | | | | | |
|----|----|----|---|---|---|
| 12 | 13 | 10 | 9 | 8 | 7 |
| 14 | 11 | 1 | 2 | 3 | 4 |
| | | | | | 5 |
| | | | | | 6 |



Fail Safe

Fail-safe index

BCM performs fail-safe control when any DTC listed below is detected.

ABMIA0642GB

INFOID:000000005712962

BCM (BODY CONTROL MODULE)

< ECU DIAGNOSIS >

| Display contents of CONSULT | Fail-safe | Cancellation |
|-----------------------------|-------------------------|---|
| U1000: CAN COMM CIRCUIT | Inhibit engine cranking | When the BCM re-establishes communication with the other modules. |
| U1010: CONTROL UNIT (CAN) | Inhibit engine cranking | When the BCM re-start communicating with the other modules. |

DTC Inspection Priority Chart

INFOID:000000005712963

If some DTCs are displayed at the same time, perform inspections one by one based on the following priority chart.

| Priority | DTC |
|----------|--|
| 1 | <ul style="list-style-type: none"> • U1000: CAN COMM CIRCUIT • U1010: CONTROL UNIT (CAN) |
| 2 | <ul style="list-style-type: none"> • B2190: NATS ANTENNA AMP • B2191: DIFFERENCE OF KEY • B2192: ID DISCORD BCM-ECM • B2193: CHAIN OF BCM-ECM |
| 3 | <ul style="list-style-type: none"> • C1729: VHCL SPEED SIG ERR |
| 4 | <ul style="list-style-type: none"> • C1704: LOW PRESSURE FL • C1705: LOW PRESSURE FR • C1706: LOW PRESSURE RR • C1707: LOW PRESSURE RL • C1708: [NO DATA] FL • C1709: [NO DATA] FR • C1710: [NO DATA] RR • C1711: [NO DATA] RL • C1712: [CHECKSUM ERR] FL • C1713: [CHECKSUM ERR] FR • C1714: [CHECKSUM ERR] RR • C1715: [CHECKSUM ERR] RL • C1716: [PRESSDATA ERR] FL • C1717: [PRESSDATA ERR] FR • C1718: [PRESSDATA ERR] RR • C1719: [PRESSDATA ERR] RL • C1720: [CODE ERR] FL • C1721: [CODE ERR] FR • C1722: [CODE ERR] RR • C1723: [CODE ERR] RL • C1724: [BATT VOLT LOW] FL • C1725: [BATT VOLT LOW] FR • C1726: [BATT VOLT LOW] RR • C1727: [BATT VOLT LOW] RL • C1735: IGNITION SIGNAL |

DTC Index

INFOID:000000005712964

NOTE:

- Details of time display
- CRNT: Displays when there is a malfunction now or after returning to the normal condition until turning ignition switch OFF → ON again.
- 1 - 39: Displayed if any previous malfunction is present when current condition is normal. It increases like 1 → 2 → 3...38 → 39 after returning to the normal condition whenever ignition switch OFF → ON. The counter remains at 39 even if the number of cycles exceeds it. It is counted from 1 again when turning ignition switch OFF → ON after returning to the normal condition if the malfunction is detected again.

A
B
C
D
E
F
G
H
I
J
K
L
M
N
O
P

MWI

BCM (BODY CONTROL MODULE)

< ECU DIAGNOSIS >

| CONSULT display | Fail-safe | Tire pressure monitor warning lamp ON | Reference page |
|--|-----------|---|------------------------|
| No DTC is detected. further testing may be required. | — | — | — |
| U1000: CAN COMM CIRCUIT | — | — | BCS-29 |
| U1010: CONTROL UNIT (CAN) | — | — | BCS-30 |
| B2190: NATS ANTENNA AMP | — | — | SEC-18 |
| B2191: DIFFERENCE OF KEY | — | — | SEC-21 |
| B2192: ID DISCORD BCM-ECM | — | — | SEC-22 |
| B2193: CHAIN OF BCM-ECM | — | — | SEC-24 |
| C1708: [NO DATA] FL | — | — | WT-14 |
| C1709: [NO DATA] FR | — | — | WT-14 |
| C1710: [NO DATA] RR | — | — | WT-14 |
| C1711: [NO DATA] RL | — | — | WT-14 |
| C1712: [CHECKSUM ERR] FL | — | — | WT-16 |
| C1713: [CHECKSUM ERR] FR | — | — | WT-16 |
| C1714: [CHECKSUM ERR] RR | — | — | WT-16 |
| C1715: [CHECKSUM ERR] RL | — | — | WT-16 |
| C1716: [PRESSDATA ERR] FL | — | — | WT-18 |
| C1717: [PRESSDATA ERR] FR | — | — | WT-18 |
| C1718: [PRESSDATA ERR] RR | — | — | WT-18 |
| C1719: [PRESSDATA ERR] RL | — | — | WT-18 |
| C1720: [CODE ERR] FL | — | — | WT-16 |
| C1721: [CODE ERR] FR | — | — | WT-16 |
| C1722: [CODE ERR] RR | — | — | WT-16 |
| C1723: [CODE ERR] RL | — | — | WT-16 |
| C1724: [BATT VOLT LOW] FL | — | — | WT-16 |
| C1725: [BATT VOLT LOW] FR | — | — | WT-16 |
| C1726: [BATT VOLT LOW] RR | — | — | WT-16 |
| C1727: [BATT VOLT LOW] RL | — | — | WT-16 |
| C1729: VHCL SPEED SIG ERR | — | — | WT-19 |
| C1735: IGNITION SIGNAL | — | — | WT-20 |

IPDM E/R (INTELLIGENT POWER DISTRIBUTION MODULE ENGINE ROOM)

< ECU DIAGNOSIS >

IPDM E/R (INTELLIGENT POWER DISTRIBUTION MODULE ENGINE ROOM)

Reference Value

INFOID:000000005712965

VALUES ON THE DIAGNOSIS TOOL

| Monitor Item | Condition | | Value/Status |
|---------------|--|--|--------------|
| MOTOR FAN REQ | Engine idle speed | Changes depending on engine coolant temperature, air conditioner operation status, vehicle speed, etc. | 0 - 100 % |
| A/C COMP REQ | A/C switch OFF | | OFF |
| | A/C switch ON | | ON |
| TAIL&CLR REQ | Lighting switch OFF | | OFF |
| | Lighting switch 1ST, 2ND, HI or AUTO (Light is illuminated) | | ON |
| HL LO REQ | Lighting switch OFF | | OFF |
| | Lighting switch 2ND HI or AUTO (Light is illuminated) | | ON |
| HL HI REQ | Lighting switch OFF | | OFF |
| | Lighting switch HI | | ON |
| FR FOG REQ | Lighting switch 2ND | Front fog lamp switch OFF | OFF |
| | | Front fog lamp switch ON | ON |
| FR WIP REQ | Ignition switch ON | Front wiper switch OFF | STOP |
| | | Front wiper switch INT | 1LOW |
| | | Front wiper switch LO | LOW |
| | | Front wiper switch HI | HI |
| WIP AUTO STOP | Ignition switch ON | Front wiper stop position | STOP P |
| | | Any position other than front wiper stop position | ACT P |
| WIP PROT | Ignition switch ON | Front wiper operates normally | OFF |
| | | Front wiper stops at fail-safe operation | BLOCK |
| ST RLY REQ | Ignition switch OFF or ACC | | OFF |
| | Ignition switch START | | ON |
| IGN RLY | Ignition switch OFF or ACC | | OFF |
| | Ignition switch ON | | ON |
| RR DEF REQ | Rear defogger switch OFF | | OFF |
| | Rear defogger switch ON | | ON |
| OIL P SW | Ignition switch OFF, ACC or engine running | | OPEN |
| | Ignition switch ON | | CLOSE |
| THFT HRN REQ | Not operated | | OFF |
| | <ul style="list-style-type: none"> Panic alarm is activated Horn is activated with VEHICLE SECURITY (THEFT WARNING) SYSTEM | | ON |
| HORN CHIRP | Not operated | | OFF |
| | Door locking with keyfob (horn chirp mode) | | ON |

IPDM E/R (INTELLIGENT POWER DISTRIBUTION MODULE ENGINE ROOM)

< ECU DIAGNOSIS >

Terminal Layout

INFOID:000000005712966

TERMINAL LAYOUT —TYPE A

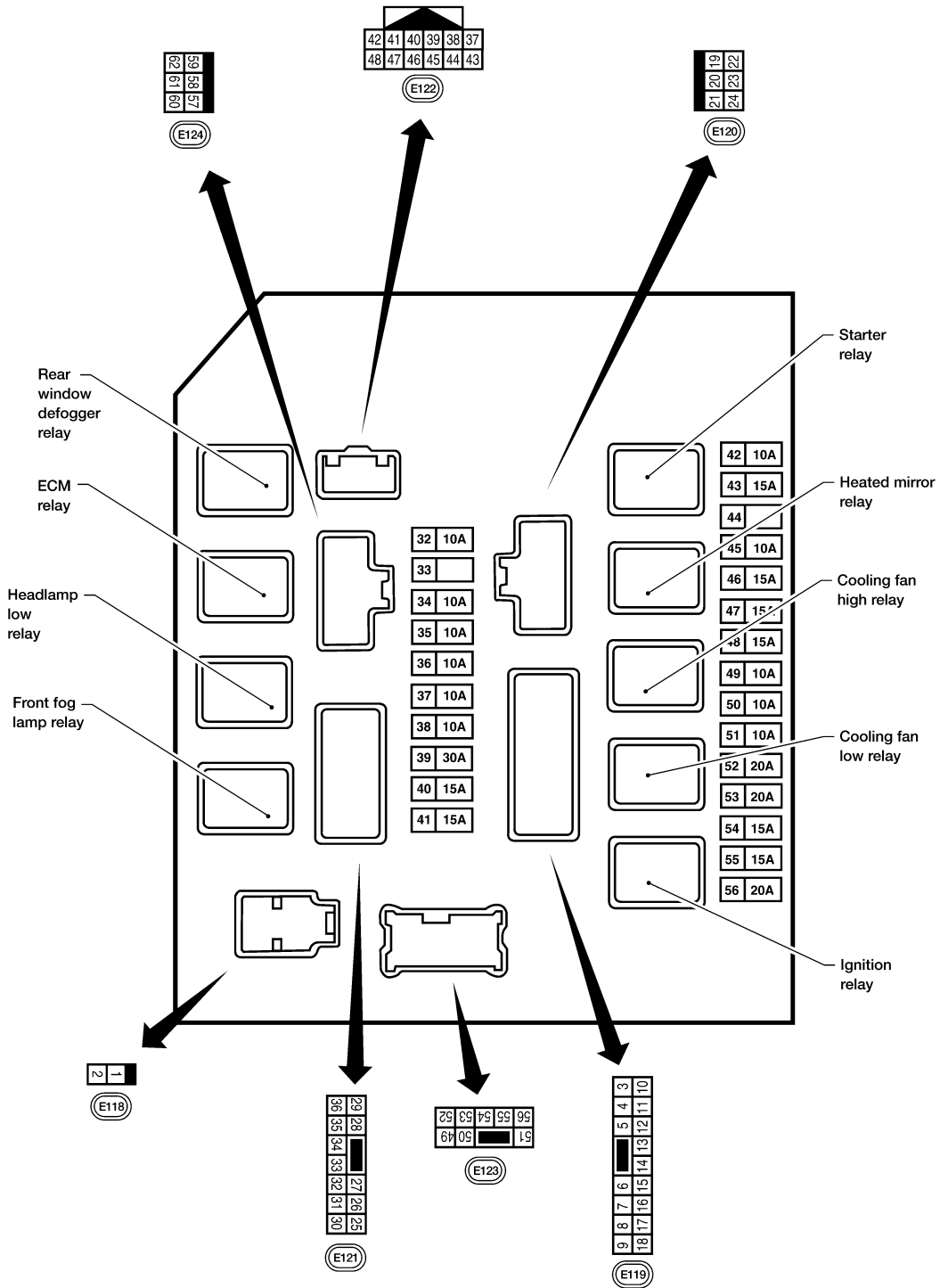

WKIA5883E

IPDM E/R (INTELLIGENT POWER DISTRIBUTION MODULE ENGINE ROOM)

< ECU DIAGNOSIS >

TERMINAL LAYOUT —TYPE B

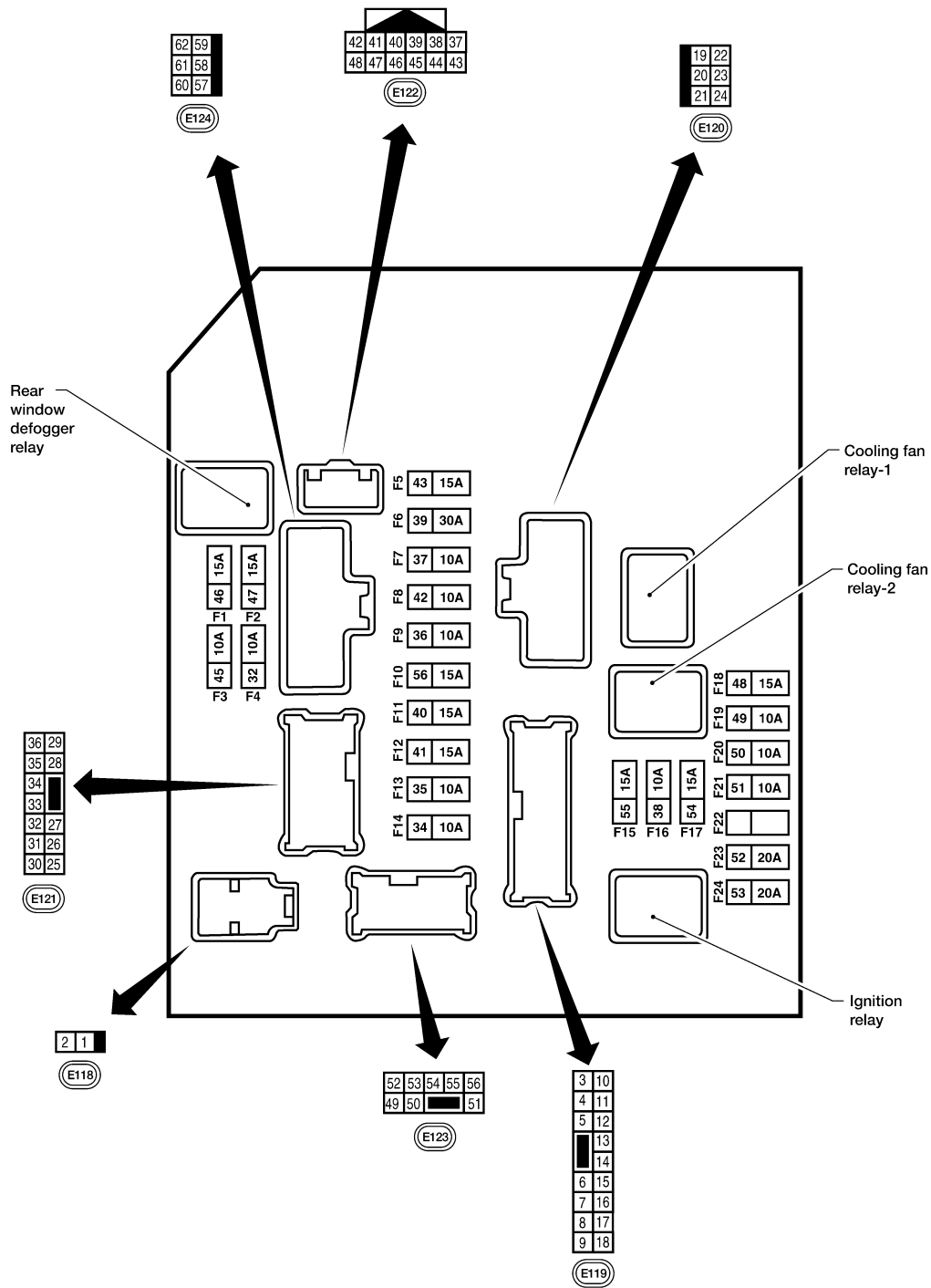

A
B
C
D
E
F
G
H
I
J
K
L
M
N
O
P

MWI

Physical Values

PHYSICAL VALUES

AAMIA0386GB

INFOID:000000005712967

IPDM E/R (INTELLIGENT POWER DISTRIBUTION MODULE ENGINE ROOM)

< ECU DIAGNOSIS >

| Terminal | Wire color | Signal name | Signal input/output | Measuring condition | | Reference value (Approx.) |
|----------|------------|--------------------------------|---------------------|---------------------|--|---------------------------|
| | | | | Ignition switch | Operation or condition | |
| 1 | W | Battery power supply | Input | OFF | — | Battery voltage |
| 2 | R | Battery power supply | Input | OFF | — | Battery voltage |
| 3 | G | ECM relay | Output | — | Ignition switch ON or START | Battery voltage |
| | | | | | Ignition switch OFF or ACC | 0V |
| 4 | P | ECM relay | Output | — | Ignition switch ON or START | Battery voltage |
| | | | | | Ignition switch OFF or ACC | 0V |
| 6 | V | Throttle control motor relay | Output | — | Ignition switch ON or START | Battery voltage |
| | | | | | Ignition switch OFF or ACC | 0V |
| 7 | BR | ECM relay control | Input | — | Ignition switch ON or START | 0V |
| | | | | | Ignition switch OFF or ACC | Battery voltage |
| 8 | W/R | Fuse 54 | Output | — | Ignition switch ON or START | Battery voltage |
| | | | | | Ignition switch OFF or ACC | 0V |
| 11 | Y | A/C compressor | Output | ON or START | A/C switch ON or defrost A/C switch | Battery voltage |
| | | | | | A/C switch OFF or defrost A/C switch | 0V |
| 12 | W/G | Ignition switch supplied power | Input | — | OFF or ACC | 0V |
| | | | | | ON or START | Battery voltage |
| 13 | R | Fuel pump relay | Output | — | Ignition switch ON or START | Battery voltage |
| | | | | | Ignition switch OFF or ACC | 0V |
| 14 | W/G | Fuse 49 | Output | — | Ignition switch ON or START | Battery voltage |
| | | | | | Ignition switch OFF or ACC | 0V |
| 15 | W/R | Fuse 50 (ABS) | Output | — | Ignition switch ON or START | Battery voltage |
| | | | | | Ignition switch OFF or ACC | 0V |
| 16 | W/G | Fuse 51 | Output | — | Ignition switch ON or START | Battery voltage |
| | | | | | Ignition switch OFF or ACC | 0V |
| 17 | W/G | Fuse 55 | Output | — | Ignition switch ON or START | Battery voltage |
| | | | | | Ignition switch OFF or ACC | 0V |
| 19 | W | Starter motor | Output | START | — | Battery voltage |
| 20 | BR | Cooling fan motor (low) | Output | ON or START | — | Battery voltage |
| 21 | GR | Ignition switch supplied power | Input | — | OFF or ACC | 0V |
| | | | | | START | Battery voltage |
| 22 | G | Battery power supply | Output | OFF | — | Battery voltage |
| 24 | P | Cooling fan motor (high) | Output | — | Conditions correct for cooling fan operation | Battery voltage |
| | | | | | Conditions not correct for cooling fan operation | 0V |

IPDM E/R (INTELLIGENT POWER DISTRIBUTION MODULE ENGINE ROOM)

< ECU DIAGNOSIS >

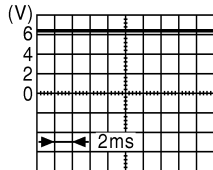
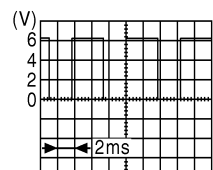
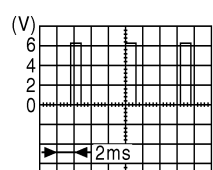
| Terminal | Wire color | Signal name | Signal input/output | Measuring condition | | Reference value (Approx.) |
|----------|------------|---|---------------------|---------------------|--|--|
| | | | | Ignition switch | Operation or condition | |
| 26 | O | Headlamp aiming motors | Output | — | Lighting switch 2nd position or AUTO, headlamp aiming switch in position | OFF 0V |
| | | | | | ON Battery voltage | |
| 27 | W/G | Fuse 38 | Output | — | Ignition switch ON or START Battery voltage | |
| | | | | | Ignition switch OFF or ACC 0V | |
| 28 | R | LH front parking and front side marker lamp | Output | OFF | Lighting switch 1st position | OFF 0V |
| | | | | | ON Battery voltage | |
| 30 | R/B | Fuse 53 | Output | — | Ignition switch ON or START Battery voltage | |
| | | | | | Ignition switch OFF or ACC 0V | |
| 32 | GR | Wiper low speed signal | Output | ON or START | Wiper switch | OFF Battery voltage |
| | | | | | LO or INT 0V | |
| 35 | L | Wiper high speed signal | Output | ON or START | Wiper switch | OFF, LO, INT Battery voltage |
| | | | | | HI 0V | |
| 37 | Y | Power generation command signal | Output | — | Ignition switch ON |  <p style="text-align: right; font-size: small;">JPMIA0001GB</p> <p style="text-align: center;">6.3 V</p> |
| | | | | | 40% is set on "Active test," "ALTERNATOR DUTY" of "ENGINE" |  <p style="text-align: right; font-size: small;">JPMIA0002GB</p> <p style="text-align: center;">3.8 V</p> |
| | | | | | 40% is set on "Active test," "ALTERNATOR DUTY" of "ENGINE" |  <p style="text-align: right; font-size: small;">JPMIA0003GB</p> <p style="text-align: center;">1.4 V</p> |
| 38 | B | Ground | Input | — | — | 0V |
| 39 | L | CAN-H | — | ON | — | — |
| 40 | P | CAN-L | — | ON | — | — |
| 42 | GR | Oil pressure switch | Input | — | Engine running Battery voltage | |
| | | | | | Engine stopped 0V | |

A
B
C
D
E
F
G
H
I
J
K
L
M
N
O
P

MWI

IPDM E/R (INTELLIGENT POWER DISTRIBUTION MODULE ENGINE ROOM)

< ECU DIAGNOSIS >

| Terminal | Wire color | Signal name | Signal input/output | Measuring condition | | | Reference value (Approx.) |
|----------|------------|---|---------------------|---------------------|--|--------------|---------------------------|
| | | | | Ignition switch | Operation or condition | | |
| 43 | G | Wiper auto stop signal | Input | ON or START | Wiper switch | OFF, LO, INT | Battery voltage |
| 45 | LG | Horn relay control | Input | ON | When door locks are operated using keyfob (OFF → ON)* | | Battery voltage → 0V |
| 46 | V | Fuel pump relay control | Input | — | Ignition switch ON or START | | 0V |
| | | | | | Ignition switch OFF or ACC | | Battery voltage |
| 47 | O | Throttle control motor relay control | Input | — | Ignition switch ON or START | | 0V |
| | | | | | Ignition switch OFF or ACC | | Battery voltage |
| 48 | R | Starter relay (inhibit switch) | Input | ON or START | Selector lever in "P" or "N" | | 0V |
| | | | | | Selector lever any other position | | Battery voltage |
| 49 | GR | Front RH parking and front side marker lamp | Output | OFF | Lighting switch 1st position | OFF | 0V |
| | | | | | | ON | Battery voltage |
| 50 | W | Front fog lamp (LH) | Output | ON or START | Lighting switch must be in the 2nd position (LOW beam is ON) and the front fog lamp switch | OFF | 0V |
| | | | | | | ON | Battery voltage |
| 51 | V | Front fog lamp (RH) | Output | ON or START | Lighting switch must be in the 2nd position (LOW beam is ON) and the front fog lamp switch | OFF | 0V |
| | | | | | | ON | Battery voltage |
| 52 | P | LH low beam head-lamp | Output | — | Lighting switch in 2nd position | | Battery voltage |
| 54 | R | RH low beam head-lamp | Output | — | Lighting switch in 2nd position | | Battery voltage |
| 55 | G | LH high beam head-lamp | Output | — | Lighting switch in 2nd position and placed in HIGH or PASS position | | Battery voltage |
| 56 | L | RH high beam head-lamp | Output | — | Lighting switch in 2nd position and placed in HIGH or PASS position | | Battery voltage |
| 57 | GR | Parking, license, and tail lamp | Output | ON | Lighting switch 1st position | OFF | 0V |
| | | | | | | ON | Battery voltage |
| 59 | B | Ground | Input | — | — | | 0V |
| 60 | GR | Rear window defogger relay | Output | ON or START | Rear defogger switch ON | | Battery voltage |
| | | | | | Rear defogger switch OFF | | 0V |

*: When horn reminder is ON

IPDM E/R (INTELLIGENT POWER DISTRIBUTION MODULE ENGINE ROOM)

< ECU DIAGNOSIS >

Wiring Diagram

INFOID:000000005712968

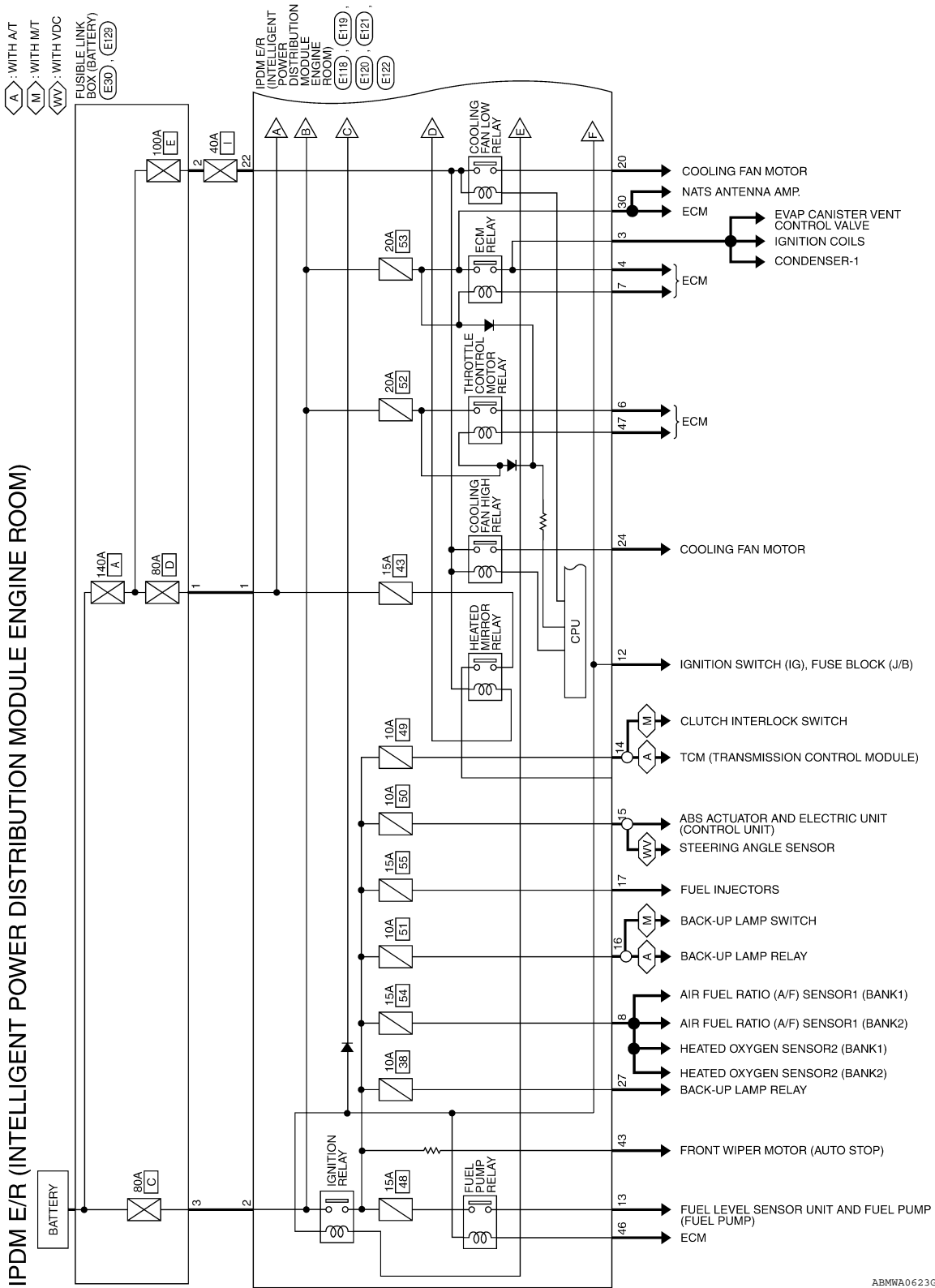

ABMWA0623GB

A
B
C
D
E
F
G
H
I
J
K
L
M
N
O
P



IPDM E/R (INTELLIGENT POWER DISTRIBUTION MODULE ENGINE ROOM)

< ECU DIAGNOSIS >

(A) : WITH A/T
 (FL) : WITH FRONT FOG LAMPS
 (M) : WITH M/T

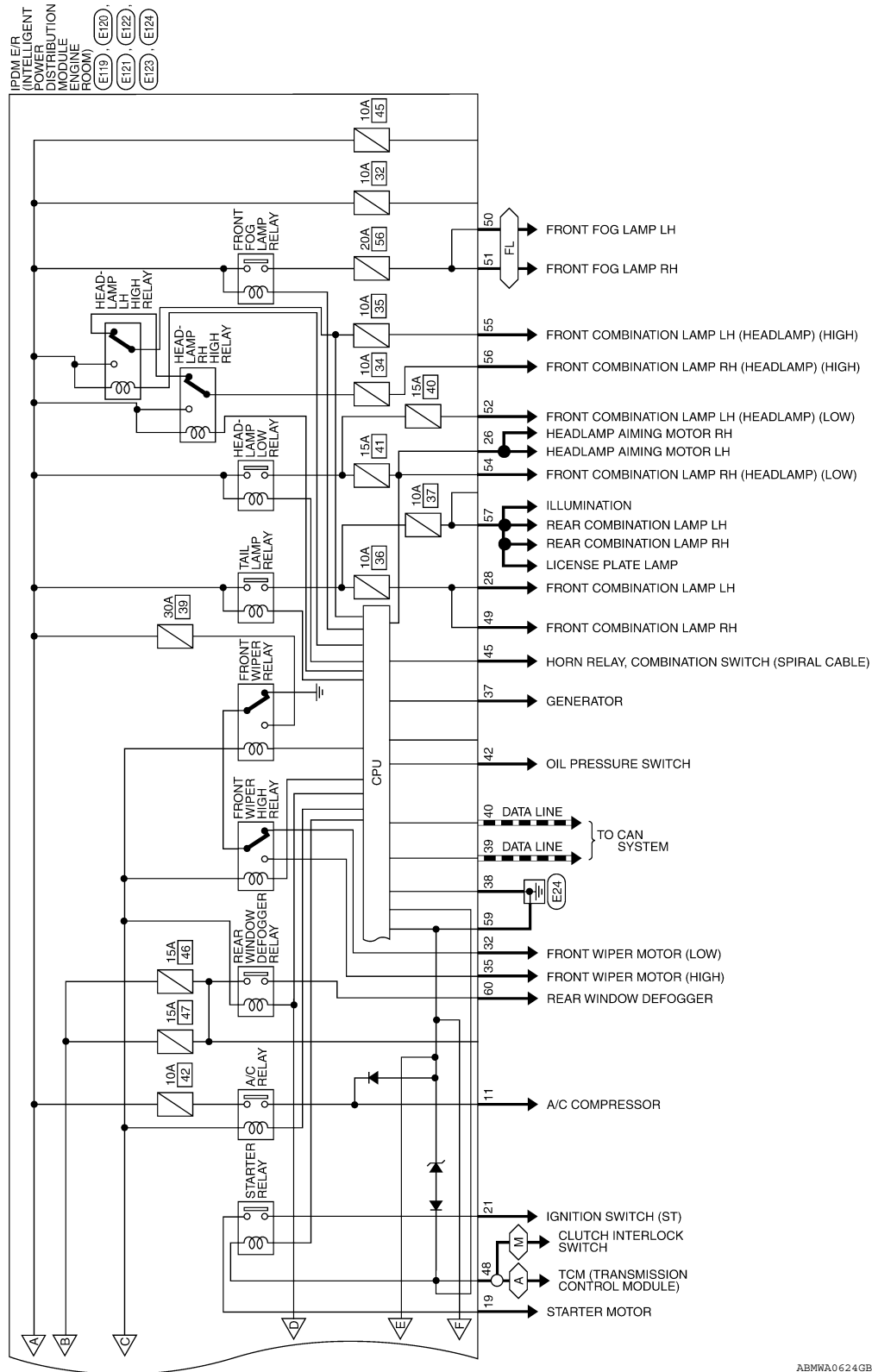

ABMWA0624GB

IPDM E/R (INTELLIGENT POWER DISTRIBUTION MODULE ENGINE ROOM)

< ECU DIAGNOSIS >

IPDM E/R (INTELLIGENT POWER DISTRIBUTION MODULE ENGINE ROOM) CONNECTORS

| | |
|-----------------|----------------------------|
| Connector No. | E30 |
| Connector Name | FUSIBLE LINK BOX (BATTERY) |
| Connector Color | - |



| Terminal No. | Color of Wire | Signal Name |
|--------------|---------------|-------------|
| 3 | R | - |

| | |
|-----------------|--|
| Connector No. | E118 |
| Connector Name | IPDM E/R (INTELLIGENT POWER DISTRIBUTION MODULE ENGINE ROOM) |
| Connector Color | BLACK |



| Terminal No. | Color of Wire | Signal Name |
|--------------|---------------|-------------|
| 1 | W | F/L USM |
| 2 | R | F/L MAIN |

| | |
|-----------------|--|
| Connector No. | E119 |
| Connector Name | IPDM E/R (INTELLIGENT POWER DISTRIBUTION MODULE ENGINE ROOM) |
| Connector Color | WHITE |



| Terminal No. | Color of Wire | Signal Name |
|--------------|---------------|-------------|
| 3 | G | IGN COIL |
| 4 | P | ECM |
| 5 | - | - |
| 6 | V | ETC |

| Terminal No. | Color of Wire | Signal Name |
|--------------|---------------|-------------------|
| 7 | BR | ECM RLY CONT |
| 8 | W/R | O2 SENSOR |
| 9 | - | - |
| 10 | - | - |
| 11 | Y | A/C COMPRESSOR |
| 12 | W/G | IGN SW (IG) |
| 13 | R | FUEL PUMP |
| 14 | W/G | AT ECU IGN SUPPLY |
| 15 | W/R | ABS IGN SUPPLY |
| 16 | W/G | REVERSE LAMP |
| 17 | W/G | INJECTOR |
| 18 | - | - |

| | |
|-----------------|--|
| Connector No. | E120 |
| Connector Name | IPDM E/R (INTELLIGENT POWER DISTRIBUTION MODULE ENGINE ROOM) |
| Connector Color | WHITE |

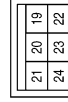

| Terminal No. | Color of Wire | Signal Name |
|--------------|---------------|---------------|
| 19 | W | STARTER MTR |
| 20 | BR | F/L MOTOR FAN |
| 21 | GR | IGN SW (ST) |
| 22 | G | F/L M/FAN |
| 23 | - | - |
| 24 | P | MOTOR FAN 2 |

A
B
C
D
E
F
G
H
I
J
K
L
M
N
O
P



IPDM E/R (INTELLIGENT POWER DISTRIBUTION MODULE ENGINE ROOM)

< ECU DIAGNOSIS >

| | |
|-----------------|--|
| Connector No. | E123 |
| Connector Name | IPDM E/R (INTELLIGENT POWER DISTRIBUTION MODULE ENGINE ROOM) |
| Connector Color | BROWN |



| | | |
|----|----|----|
| 51 | 50 | 49 |
| 56 | 55 | 54 |
| 53 | 52 | 51 |

| Terminal No. | Color of Wire | Signal Name |
|--------------|---------------|----------------|
| 49 | GR | ILLUMINATION |
| 50 | W | FR FOG LAMP LH |
| 51 | V | FR FOG LAMP RH |
| 52 | P | H/LAMP LO LH |
| 53 | - | - |
| 54 | R | H/LAMP LO RH |
| 55 | G | H/LAMP HI LH |
| 56 | L | H/LAMP HI RH |

| | |
|-----------------|--|
| Connector No. | E122 |
| Connector Name | IPDM E/R (INTELLIGENT POWER DISTRIBUTION MODULE ENGINE ROOM) |
| Connector Color | WHITE |



| | | | | | |
|----|----|----|----|----|----|
| 42 | 41 | 40 | 39 | 38 | 37 |
| 46 | 47 | 46 | 45 | 44 | 43 |

| Terminal No. | Color of Wire | Signal Name |
|--------------|---------------|--------------------|
| 37 | Y | ALT-C CONT |
| 38 | B | GND (SIGNAL) |
| 39 | L | CAN-H |
| 40 | P | CAN-L |
| 41 | - | - |
| 42 | GR | OIL PRESSURE SW |
| 43 | G | AUTO STOP SW |
| 44 | - | - |
| 45 | LG | ANT THEFT HORN |
| 46 | V | FUEL PUMP RLY CONT |
| 47 | O | ETC RLY CONT |
| 48 | R | RANGE SW |

| | |
|-----------------|--|
| Connector No. | E121 |
| Connector Name | IPDM E/R (INTELLIGENT POWER DISTRIBUTION MODULE ENGINE ROOM) |
| Connector Color | BROWN |



| | | | | |
|----|----|----|----|----|
| 29 | 28 | 27 | 26 | 25 |
| 36 | 35 | 34 | 33 | 32 |
| 31 | 30 | | | |

| Terminal No. | Color of Wire | Signal Name |
|--------------|---------------|--------------------|
| 25 | - | - |
| 26 | O | H/LAMP LEVELIZE |
| 27 | W/G | TTOW REV LAMP |
| 28 | R | CLEARANCE FRONT LH |
| 29 | - | - |
| 30 | R/B | ECM BAT |
| 31 | - | - |
| 32 | GR | FR WIPER LO |
| 33 | - | - |
| 34 | - | - |
| 35 | L | FR WIPER HI |
| 36 | - | - |

| | |
|-----------------|----------------------------|
| Connector No. | E129 |
| Connector Name | FUSIBLE LINK BOX (BATTERY) |
| Connector Color | BLACK |



| | |
|---|---|
| 2 | 1 |
|---|---|

| Terminal No. | Color of Wire | Signal Name |
|--------------|---------------|-------------|
| 1 | W | - |
| 2 | R | - |

| Terminal No. | Color of Wire | Signal Name |
|--------------|---------------|-------------|
| 57 | GR | TAIL LAMP |
| 58 | - | - |
| 59 | B | GND (POWER) |
| 60 | GR | RR DEF |
| 61 | - | - |
| 62 | - | - |

| | |
|-----------------|--|
| Connector No. | E124 |
| Connector Name | IPDM E/R (INTELLIGENT POWER DISTRIBUTION MODULE ENGINE ROOM) |
| Connector Color | BLACK |



| | | |
|----|----|----|
| 59 | 58 | 57 |
| 62 | 61 | 60 |

ABM1A1.65.0GB

INFOID:000000005712969

Fail Safe

CAN COMMUNICATION CONTROL

When CAN communication with ECM and BCM is impossible, IPDM E/R performs fail-safe control. After CAN communication recovers normally, it also returns to normal control.

If No CAN Communication Is Available With ECM

IPDM E/R (INTELLIGENT POWER DISTRIBUTION MODULE ENGINE ROOM)

< ECU DIAGNOSIS >

| Control part | Fail-safe in operation |
|--------------|--|
| Cooling fan | <ul style="list-style-type: none"> • Turns ON the cooling fan relay when the ignition switch is turned ON • Turns OFF the cooling fan relay when the ignition switch is turned OFF |

If No CAN Communication Is Available With BCM

| Control part | Fail-safe in operation |
|--|--|
| Headlamp | <ul style="list-style-type: none"> • Turns ON the headlamp low relay when the ignition switch is turned ON • Turns OFF the headlamp low relay when the ignition switch is turned OFF • Headlamp (LH/RH) high relays OFF |
| <ul style="list-style-type: none"> • Parking lamps • License plate lamps • Tail lamps | <ul style="list-style-type: none"> • Turns ON the tail lamp relay when the ignition switch is turned ON • Turns OFF the tail lamp relay when the ignition switch is turned OFF |
| Front wiper | <ul style="list-style-type: none"> • The status just before activation of fail-safe control is maintained until the ignition switch is turned OFF while the front wiper is operating at LO or HI speed. • The wiper is operated at LO speed until the ignition switch is turned OFF if the fail-safe control is activated while the front wiper is set in the INT mode and the front wiper motor is operating. |
| Rear window defogger | Rear window defogger relay OFF |
| A/C compressor | A/C relay OFF |
| Front fog lamps (if equipped) | Front fog lamp relay OFF |

IGNITION RELAY MALFUNCTION DETECTION FUNCTION

- IPDM E/R monitors the voltage at the contact circuit and excitation coil circuit of the ignition relay inside it.
- IPDM E/R judges the ignition relay error if the voltage differs between the contact circuit and the excitation coil circuit.
- If the ignition relay cannot turn OFF due to contact seizure, it activates the tail lamp relay for 10 minutes to alert the user to the ignition relay malfunction when the ignition switch is turned OFF.

| Ignition switch | Ignition relay | Tail lamp relay |
|-----------------|----------------|-----------------|
| ON | ON | — |
| OFF | OFF | — |

NOTE:

The tail lamp turns OFF when the ignition switch is turned ON.

FRONT WIPER CONTROL

IPDM E/R detects front wiper stop position by a front wiper auto stop signal.

When a front wiper auto stop signal is in the conditions listed below, IPDM E/R stops power supply to wiper after repeating a front wiper 10 second activation and 20 second stop five times.

| Ignition switch | Front wiper switch | Auto stop signal |
|-----------------|--------------------|--|
| ON | OFF | Front wiper stop position signal cannot be input 10 seconds. |
| | ON | The signal does not change for 10 seconds. |

NOTE:

This operation status can be confirmed on the IPDM E/R “DATA MONITOR” that displays “Block” for the item “WIP PROT” while the wiper is stopped.

STARTER MOTOR PROTECTION FUNCTION

IPDM E/R turns OFF the starter control relay to protect the starter motor when the starter control relay remains active for 90 seconds.

A
B
C
D
E
F
G
H
I
J
K
L
M
O
P

MWI

IPDM E/R (INTELLIGENT POWER DISTRIBUTION MODULE ENGINE ROOM)

< ECU DIAGNOSIS >

DTC Index

INFOID:000000005712970

| CONSULT-III display | Fail-safe | TIME ^{NOTE} | | Refer to |
|--|-----------|----------------------|--------|------------------------|
| No DTC is detected. further testing may be required. | — | — | — | — |
| U1000: CAN COMM CIRCUIT | × | CRNT | 1 – 39 | PCS-17 |

NOTE:

The details of TIME display are as follows.

- CRNT: The malfunctions that are detected now
- 1 - 39: The number is indicated when it is normal at present and a malfunction was detected in the past. It increases like 0 → 1 → 2 ... 38 → 39 after returning to the normal condition whenever IGN OFF → ON. It is fixed to 39 until the self-diagnosis results are erased if it is over 39. It returns to 0 when a malfunction is detected again in the process.

THE FUEL GAUGE POINTER DOES NOT MOVE

< SYMPTOM DIAGNOSIS >

SYMPTOM DIAGNOSIS

THE FUEL GAUGE POINTER DOES NOT MOVE

Description

INFOID:000000005281799

Fuel gauge needle will not move from a certain position.

Diagnosis Procedure

INFOID:000000005281800

1. CHECK COMBINATION METER INPUT SIGNAL

1. Select "METER/M&A" on CONSULT-III.
2. Using "FUEL METER" of "DATA MONITOR", compare the monitor value with the fuel gauge reading on the combination meter. Refer to [MWI-30, "Component Function Check"](#).

Does monitor value match fuel gauge reading?

YES >> GO TO 2

NO >> Replace combination meter. Refer to [MWI-86, "Removal and Installation"](#).

2. CHECK FUEL LEVEL SENSOR SIGNAL CIRCUIT

Check the fuel level sensor signal circuit. Refer to [MWI-30, "Diagnosis Procedure"](#).

Is the inspection result normal?

YES >> GO TO 3

NO >> Repair harness or connector.

3. CHECK FUEL LEVEL SENSOR UNIT

Perform a unit check for the fuel level sensor unit. Refer to [MWI-31, "Component Inspection"](#).

Is the inspection result normal?

YES >> GO TO 4

NO >> Replace fuel level sensor unit. Refer to [FL-11, "Removal and Installation"](#).

4. CHECK FLOAT INTERFERENCE

Check that the float arm does not interfere or bind with any of the components in the fuel tank.

Is the inspection result normal?

YES >> Replace combination meter. Refer to [MWI-86, "Removal and Installation"](#).

NO >> Repair or replace malfunctioning parts.

A
B
C
D
E
F
G
H
I
J
K
L
M
O
P

MWI

THE FUEL GAUGE POINTER DOES NOT MOVE TO "F" WHEN REFUELING

< SYMPTOM DIAGNOSIS >

THE FUEL GAUGE POINTER DOES NOT MOVE TO "F" WHEN REFUELING

Description

INFOID:000000005281801

The fuel gauge needle will not move to "F" position when refueling.

Diagnosis Procedure

INFOID:000000005281802

1.OBSERVE FUEL GAUGE

Does it take a long time for the pointer to move to FULL position?

YES or NO

YES >> GO TO 2

NO >> GO TO 3

2.IDENTIFY FUELING CONDITION

Was the vehicle fueled with the ignition switch ON?

YES or NO

YES >> Be sure to fuel the vehicle with the ignition switch OFF. Otherwise, it will take a long time to move to FULL position because of the characteristic of the fuel gauge.

NO >> GO TO 3

3.OBSERVE VEHICLE POSITION

Is the vehicle parked on an incline?

YES or NO

YES >> Check the fuel level indication with vehicle on a level surface.

NO >> GO TO 4

4.OBSERVE FUEL GAUGE POINTER

During driving, does the fuel gauge pointer move gradually toward EMPTY position?

YES or NO

YES >> Check the components. Refer to [MWI-31. "Component Inspection"](#).

NO >> The float arm may interfere or bind with any of the components in the fuel tank.

THE OIL PRESSURE WARNING LAMP DOES NOT TURN ON

< SYMPTOM DIAGNOSIS >

THE OIL PRESSURE WARNING LAMP DOES NOT TURN ON

Description

INFOID:000000005281803

The oil pressure warning lamp stays off when the ignition switch is turned ON.

Diagnosis Procedure

INFOID:000000005281804

1. CHECK OIL PRESSURE WARNING LAMP

Perform IPDM E/R auto active test. Refer to [PCS-13, "Diagnosis Description"](#).

Is oil pressure warning lamp illuminated?

YES >> GO TO 2

NO >> Replace combination meter. Refer to [MWI-86, "Removal and Installation"](#).

2. CHECK OIL PRESSURE SWITCH SIGNAL CIRCUIT

Check the oil pressure switch signal circuit. Refer to [MWI-33, "Diagnosis Procedure"](#).

Is the inspection result normal?

YES >> GO TO 3

NO >> Repair harness or connector.

3. CHECK OIL PRESSURE SWITCH UNIT

Perform a unit check for the oil pressure switch. Refer to [MWI-33, "Component Inspection"](#).

Is the inspection result normal?

YES >> Replace IPDM E/R. Refer to [PCS-32, "Removal and Installation of IPDM E/R"](#).

NO >> Replace oil pressure switch.

A
B
C
D
E
F
G
H
I
J
K
L
M
O
P

MWI

THE OIL PRESSURE WARNING LAMP DOES NOT TURN OFF

< SYMPTOM DIAGNOSIS >

THE OIL PRESSURE WARNING LAMP DOES NOT TURN OFF

Description

INFOID:000000005281805

The oil pressure warning lamp remains illuminated while the engine is running (normal oil pressure).

Diagnosis Procedure

INFOID:000000005281806

Regarding Wiring Diagram information, refer to [MWI-36, "Wiring Diagram"](#).

1. CHECK OIL PRESSURE WARNING LAMP

Perform IPDM E/R auto active test. Refer to [PCS-13, "Diagnosis Description"](#).

Is oil pressure warning lamp illuminated?

YES >> GO TO 2

NO >> Replace combination meter. Refer to [MWI-86, "Removal and Installation"](#).

2. CHECK IPDM E/R OUTPUT VOLTAGE

1. Turn ignition switch OFF.
2. Disconnect the oil pressure switch connector.
3. Turn ignition switch ON.
4. Check voltage between the oil pressure switch harness connector E208 terminal 1 and ground.

1 – Ground : Approx. 12V

Is the inspection result normal?

YES >> GO TO 3

NO >> GO TO 4

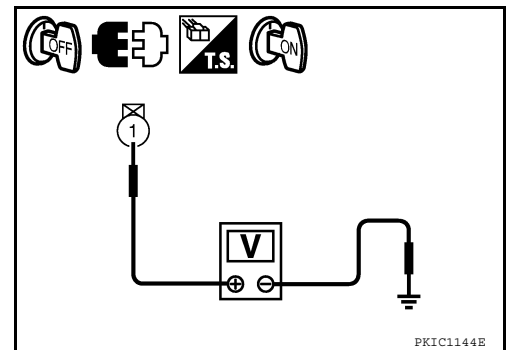

3. CHECK OIL PRESSURE SWITCH

Perform a unit check for the oil pressure switch. Refer to [MWI-33, "Component Inspection"](#).

Is the inspection result normal?

YES >> Replace IPDM E/R. Refer to [PCS-32, "Removal and Installation of IPDM E/R"](#).

NO >> Replace oil pressure switch.

4. CHECK OIL PRESSURE SWITCH SIGNAL CIRCUIT

Check the oil pressure switch signal circuit. Refer to [MWI-33, "Diagnosis Procedure"](#).

Is the inspection result normal?

YES >> Replace IPDM E/R. Refer to [PCS-32, "Removal and Installation of IPDM E/R"](#).

NO >> Repair harness or connector.

PRECAUTIONS

< PRECAUTION >

PRECAUTION

PRECAUTIONS

Precaution for Supplemental Restraint System (SRS) "AIR BAG" and "SEAT BELT PRE-TENSIONER"

INFOID:000000005774541

The Supplemental Restraint System such as "AIR BAG" and "SEAT BELT PRE-TENSIONER", used along with a front seat belt, helps to reduce the risk or severity of injury to the driver and front passenger for certain types of collision. This system includes seat belt switch inputs and dual stage front air bag modules. The SRS system uses the seat belt switches to determine the front air bag deployment, and may only deploy one front air bag, depending on the severity of a collision and whether the front occupants are belted or unbelted. Information necessary to service the system safely is included in the SR and SB section of this Service Manual.

WARNING:

- To avoid rendering the SRS inoperative, which could increase the risk of personal injury or death in the event of a collision which would result in air bag inflation, all maintenance must be performed by an authorized NISSAN/INFINITI dealer.
- Improper maintenance, including incorrect removal and installation of the SRS, can lead to personal injury caused by unintentional activation of the system. For removal of Spiral Cable and Air Bag Module, see the SR section.
- Do not use electrical test equipment on any circuit related to the SRS unless instructed to in this Service Manual. SRS wiring harnesses can be identified by yellow and/or orange harnesses or harness connectors.

PRECAUTIONS WHEN USING POWER TOOLS (AIR OR ELECTRIC) AND HAMMERS

WARNING:

- When working near the Airbag Diagnosis Sensor Unit or other Airbag System sensors with the Ignition ON or engine running, DO NOT use air or electric power tools or strike near the sensor(s) with a hammer. Heavy vibration could activate the sensor(s) and deploy the air bag(s), possibly causing serious injury.
- When using air or electric power tools or hammers, always switch the Ignition OFF, disconnect the battery, and wait at least 3 minutes before performing any service.

A
B
C
D
E
F
G
H
I
J
K
L
M
O
P

MWI

COMBINATION METER

< ON-VEHICLE REPAIR >

ON-VEHICLE REPAIR

COMBINATION METER

Removal and Installation

INFOID:000000005281808

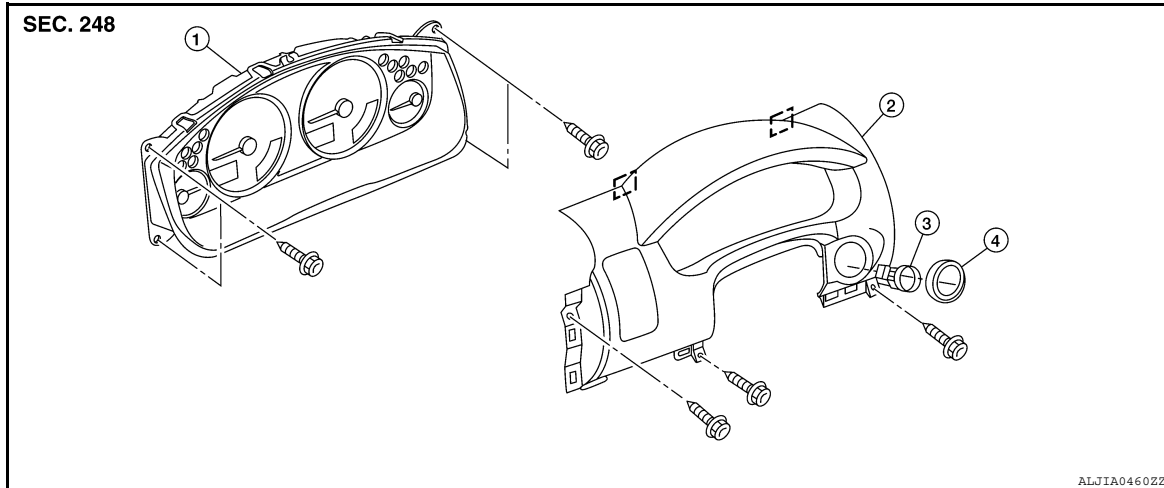

- | | | |
|-----------------------------|------------------|-------------------------------|
| 1. Combination meter | 2. Cluster lid A | 3. Ignition key lamp assembly |
| 4. Steering lock escutcheon | ☐ Metal clip | |

REMOVAL

1. Remove the cluster lid A. Refer to [JP-11, "Removal and Installation"](#).
2. Remove the combination meter screws, using power tool.
3. Pull out the combination meter and disconnect the combination meter electrical connector.

INSTALLATION

Installation is in the reverse order of removal.