

SECTION **SE**  
SEAT

A  
B  
C  
D  
E  
F  
G  
H  
I  
SE  
K  
L  
M  
N  
O  
P

CONTENTS

<b>SERVICE INFORMATION</b> .....	2	<b>CLIP LIST</b> .....	10
<b>SQUEAK AND RATTLE TROUBLE DIAG- NOSES</b> .....	2	Descriptions for Clips .....	10
Work Flow .....	2	<b>REMOVAL AND INSTALLATION</b> .....	14
Generic Squeak and Rattle Troubleshooting .....	4	<b>FRONT SEAT</b> .....	14
Diagnostic Worksheet .....	6	Component .....	14
<b>PRECAUTION</b> .....	8	Removal and Installation .....	17
<b>PRECAUTIONS</b> .....	8	<b>REAR SEAT</b> .....	23
Precaution for Supplemental Restraint System (SRS) "AIR BAG" and "SEAT BELT PRE-TEN- SIONER" .....	8	Removal and Installation .....	23
Precaution for Work .....	8	<b>UNIT DISASSEMBLY AND ASSEMBLY</b> ...	24
<b>PREPARATION</b> .....	9	<b>FRONT SEAT</b> .....	24
<b>PREPARATION</b> .....	9	Component .....	24
Special Service Tool .....	9	Disassembly and Assembly .....	27
Commercial Service Tool .....	9	<b>REAR SEAT</b> .....	30
		Disassembly and Assembly .....	30

# SQUEAK AND RATTLE TROUBLE DIAGNOSES

< SERVICE INFORMATION >

## SERVICE INFORMATION

### SQUEAK AND RATTLE TROUBLE DIAGNOSES

#### Work Flow

INFOID:000000007360054

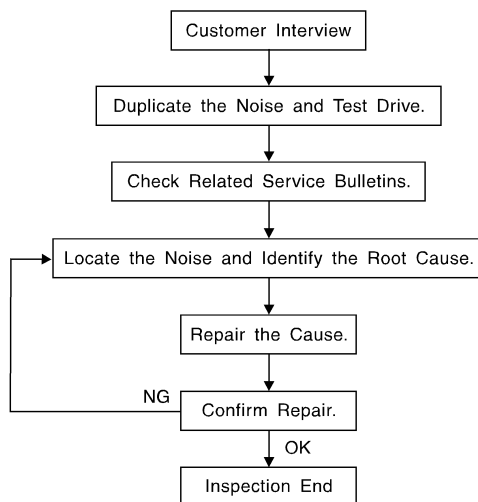

SBT842

#### CUSTOMER INTERVIEW

Interview the customer if possible, to determine the conditions that exist when the noise occurs. Use the Diagnostic Worksheet during the interview to document the facts and conditions when the noise occurs and any customer's comments; refer to [SE-6, "Diagnostic Worksheet"](#). This information is necessary to duplicate the conditions that exist when the noise occurs.

- The customer may not be able to provide a detailed description or the location of the noise. Attempt to obtain all the facts and conditions that exist when the noise occurs (or does not occur).
- If there is more than one noise in the vehicle, be sure to diagnose and repair the noise that the customer is concerned about. This can be accomplished by test driving the vehicle with the customer.
- After identifying the type of noise, isolate the noise in terms of its characteristics. The noise characteristics are provided so the customer, service adviser and technician are all speaking the same language when defining the noise.
- Squeak —(Like tennis shoes on a clean floor)  
Squeak characteristics include the light contact/fast movement/brought on by road conditions/hard surfaces = higher pitch noise/softer surfaces = lower pitch noises/edge to surface = chirping.
- Creak—(Like walking on an old wooden floor)  
Creak characteristics include firm contact/slow movement/twisting with a rotational movement/pitch dependent on materials/often brought on by activity.
- Rattle—(Like shaking a baby rattle)  
Rattle characteristics include the fast repeated contact/vibration or similar movement/loose parts/missing clip or fastener/incorrect clearance.
- Knock —(Like a knock on a door)  
Knock characteristics include hollow sounding/sometimes repeating/often brought on by driver action.
- Tick—(Like a clock second hand)  
Tick characteristics include gentle contacting of light materials/loose components/can be caused by driver action or road conditions.
- Thump—(Heavy, muffled knock noise)  
Thump characteristics include softer knock/dead sound often brought on by activity.
- Buzz—(Like a bumble bee)  
Buzz characteristics include high frequency rattle/firm contact.
- Often the degree of acceptable noise level will vary depending upon the person. A noise that you may judge as acceptable may be very irritating to the customer.
- Weather conditions, especially humidity and temperature, may have a great effect on noise level.

#### DUPLICATE THE NOISE AND TEST DRIVE

# SQUEAK AND RATTLE TROUBLE DIAGNOSES

## < SERVICE INFORMATION >

If possible, drive the vehicle with the customer until the noise is duplicated. Note any additional information on the Diagnostic Worksheet regarding the conditions or location of the noise. This information can be used to duplicate the same conditions when you confirm the repair.

If the noise can be duplicated easily during the test drive, to help identify the source of the noise, try to duplicate the noise with the vehicle stopped by doing one or all of the following:

- 1) Close a door.
  - 2) Tap or push/pull around the area where the noise appears to be coming from.
  - 3) Rev the engine.
  - 4) Use a floor jack to recreate vehicle "twist".
  - 5) At idle, apply engine load (electrical load, half-clutch on M/T model, drive position on CVT and A/T models).
  - 6) Raise the vehicle on a hoist and hit a tire with a rubber hammer.
- Drive the vehicle and attempt to duplicate the conditions the customer states exist when the noise occurs.
  - If it is difficult to duplicate the noise, drive the vehicle slowly on an undulating or rough road to stress the vehicle body.

## CHECK RELATED SERVICE BULLETINS

After verifying the customer concern or symptom, check ASIST for Technical Service Bulletins (TSBs) related to that concern or symptom.

If a TSB relates to the symptom, follow the procedure to repair the noise.

## LOCATE THE NOISE AND IDENTIFY THE ROOT CAUSE

1. Narrow down the noise to a general area. To help pinpoint the source of the noise, use a listening tool (Chassis Ear: J-39570, Engine Ear: J-39565 and mechanic's stethoscope).
2. Narrow down the noise to a more specific area and identify the cause of the noise by:
  - removing the components in the area that you suspect the noise is coming from.  
Do not use too much force when removing clips and fasteners, otherwise clips and fasteners can be broken or lost during the repair, resulting in the creation of new noise.
  - tapping or pushing/pulling the component that you suspect is causing the noise.  
Do not tap or push/pull the component with excessive force, otherwise the noise will be eliminated only temporarily.
  - feeling for a vibration with your hand by touching the component(s) that you suspect is (are) causing the noise.
  - placing a piece of paper between components that you suspect are causing the noise.
  - looking for loose components and contact marks.Refer to [SE-4. "Generic Squeak and Rattle Troubleshooting"](#).

## REPAIR THE CAUSE

- If the cause is a loose component, tighten the component securely.
- If the cause is insufficient clearance between components:
  - separate components by repositioning or loosening and retightening the component, if possible.
  - insulate components with a suitable insulator such as urethane pads, foam blocks, felt cloth tape or urethane tape. A NISSAN Squeak and Rattle Kit (J-43980) is available through your authorized NISSAN Parts Department.

### **CAUTION:**

**Do not use excessive force as many components are constructed of plastic and may be damaged.**

**Always check with the Parts Department for the latest parts information.**

**The following materials are contained in the NISSAN Squeak and Rattle Kit (J-43980). Each item can be ordered separately as needed.**

### **URETHANE PADS [1.5 mm (0.059 in) thick]**

**Insulates connectors, harness, etc.**

**76268-9E005: 100×135 mm (3.94×5.31 in)/76884-71L01: 60×85 mm (2.36×3.35 in)/76884-71L02: 15×25 mm (0.59×0.98 in)**

### **INSULATOR (Foam blocks)**

**Insulates components from contact. Can be used to fill space behind a panel.**

**73982-9E000: 45 mm (1.77 in) thick, 50×50 mm (1.97×1.97 in)/73982-50Y00: 10 mm (0.39 in) thick, 50×50 mm (1.97×1.97 in)**

### **INSULATOR (Light foam block)**

**80845-71L00: 30 mm (1.18 in) thick, 30×50 mm (1.18×1.97 in)**

### **FELT CLOTH TAPE**

**Used to insulate where movement does not occur. Ideal for instrument panel applications.**

**68370-4B000: 15×25 mm (0.59×0.98 in) pad/68239-13E00: 5 mm (0.20 in) wide tape roll. The following materials not found in the kit can also be used to repair squeaks and rattles.**

# SQUEAK AND RATTLE TROUBLE DIAGNOSES

## < SERVICE INFORMATION >

---

### UHMW (TEFLON) TAPE

Insulates where slight movement is present. Ideal for instrument panel applications.

### SILICONE GREASE

Used instead of UHMW tape that will be visible or not fit.

Note: Will only last a few months.

### SILICONE SPRAY

Use when grease cannot be applied.

### DUCT TAPE

Use to eliminate movement.

### CONFIRM THE REPAIR

Confirm that the cause of a noise is repaired by test driving the vehicle. Operate the vehicle under the same conditions as when the noise originally occurred. Refer to the notes on the Diagnostic Worksheet.

## Generic Squeak and Rattle Troubleshooting

INFOID:000000007360055

Refer to Table of Contents for specific component removal and installation information.

### INSTRUMENT PANEL

Most incidents are caused by contact and movement between:

1. The cluster lid A and instrument panel
2. Acrylic lens and combination meter housing
3. Instrument panel to front pillar garnish
4. Instrument panel to windshield
5. Instrument panel pins
6. Wiring harnesses behind the combination meter
7. A/C defroster duct and duct joint

These incidents can usually be located by tapping or moving the components to duplicate the noise or by pressing on the components while driving to stop the noise. Most of these incidents can be repaired by applying felt cloth tape or silicone spray (in hard to reach areas). Urethane pads can be used to insulate wiring harness.

### CAUTION:

**Do not use silicone spray to isolate a squeak or rattle. If you saturate the area with silicone, you will not be able to recheck the repair.**

### CENTER CONSOLE

Components to pay attention to include:

1. Shift selector assembly cover to finisher
2. A/C control unit and cluster lid C
3. Wiring harnesses behind audio and A/C control unit

The instrument panel repair and isolation procedures also apply to the center console.

### DOORS

Pay attention to the:

1. Finisher and inner panel making a slapping noise
2. Inside handle escutcheon to door finisher
3. Wiring harnesses tapping
4. Door striker out of alignment causing a popping noise on starts and stops

Tapping or moving the components or pressing on them while driving to duplicate the conditions can isolate many of these incidents. You can usually insulate the areas with felt cloth tape or insulator foam blocks from the NISSAN Squeak and Rattle Kit (J-43980) to repair the noise.

### TRUNK

Trunk noises are often caused by a loose jack or loose items put into the trunk by the owner.

In addition look for:

1. Trunk lid bumpers out of adjustment
2. Trunk lid striker out of adjustment
3. The trunk lid torsion bars knocking together

# SQUEAK AND RATTLE TROUBLE DIAGNOSES

## < SERVICE INFORMATION >

4. A loose license plate or bracket

Most of these incidents can be repaired by adjusting, securing or insulating the item(s) or component(s) causing the noise.

### SUNROOF/HEADLINING

Noises in the sunroof/headlining area can often be traced to one of the following:

1. Sunroof lid, rail, linkage or seals making a rattle or light knocking noise
2. Sun visor shaft shaking in the holder
3. Front or rear windshield touching headliner and squeaking

Again, pressing on the components to stop the noise while duplicating the conditions can isolate most of these incidents. Repairs usually consist of insulating with felt cloth tape.

### OVERHEAD CONSOLE (FRONT AND REAR)

Overhead console noises are often caused by the console panel clips not being engaged correctly. Most of these incidents are repaired by pushing up on the console at the clip locations until the clips engage.

In addition look for:

1. Loose harness or harness connectors.
2. Front console map/reading lamp lens loose.
3. Loose screws at console attachment points.

### SEATS

When isolating seat noise it's important to note the position the seat is in and the load placed on the seat when the noise is present. These conditions should be duplicated when verifying and isolating the cause of the noise.

Cause of seat noise include:

1. Headrest rods and holder
2. A squeak between the seat pad cushion and frame
3. The rear seatback lock and bracket

These noises can be isolated by moving or pressing on the suspected components while duplicating the conditions under which the noise occurs. Most of these incidents can be repaired by repositioning the component or applying urethane tape to the contact area.

### UNDERHOOD

Some interior noise may be caused by components under the hood or on the engine wall. The noise is then transmitted into the passenger compartment.

Causes of transmitted underhood noise include:

1. Any component installed to the engine wall
2. Components that pass through the engine wall
3. Engine wall mounts and connectors
4. Loose radiator installation pins
5. Hood bumpers out of adjustment
6. Hood striker out of adjustment

These noises can be difficult to isolate since they cannot be reached from the interior of the vehicle. The best method is to secure, move or insulate one component at a time and test drive the vehicle. Also, engine RPM or load can be changed to isolate the noise. Repairs can usually be made by moving, adjusting, securing, or insulating the component causing the noise.

A  
B  
C  
D  
E  
F  
G  
H  
I  
SE  
K  
L  
M  
N  
O  
P

# SQUEAK AND RATTLE TROUBLE DIAGNOSES

< SERVICE INFORMATION >

## Diagnostic Worksheet

INFOID:000000007360056

Dear Customer:

We are concerned about your satisfaction with your vehicle. Repairing a squeak or rattle sometimes can be very difficult. To help us fix your vehicle right the first time, please take a moment to note the area of the vehicle where the squeak or rattle occurs and under what conditions. You may be asked to take a test drive with a service advisor or technician to ensure we confirm the noise you are hearing.

### SQUEAK & RATTLE DIAGNOSTIC WORKSHEET

#### I. WHERE DOES THE NOISE COME FROM? (circle the area of the vehicle)

The illustrations are for reference only, and may not reflect the actual configuration of your vehicle.



Continue to page 2 of the worksheet and briefly describe the location of the noise or rattle. In addition, please indicate the conditions which are present when the noise occurs.

# SQUEAK AND RATTLE TROUBLE DIAGNOSES

< SERVICE INFORMATION >

## SQUEAK & RATTLE DIAGNOSTIC WORKSHEET - page 2

Briefly describe the location where the noise occurs:

---

---

### II. WHEN DOES IT OCCUR? (please check the boxes that apply)

- |   |  |
|---|--|
| <input type="checkbox"/> Anytime                      | <input type="checkbox"/> After sitting out in the rain |
| <input type="checkbox"/> 1st time in the morning      | <input type="checkbox"/> When it is raining or wet     |
| <input type="checkbox"/> Only when it is cold outside | <input type="checkbox"/> Dry or dusty conditions       |
| <input type="checkbox"/> Only when it is hot outside  | <input type="checkbox"/> Other:                        |

### III. WHEN DRIVING:

- Through driveways
- Over rough roads
- Over speed bumps
- Only about \_\_\_\_ mph
- On acceleration
- Coming to a stop
- On turns: left, right or either (circle)
- With passengers or cargo
- Other: \_\_\_\_\_
- After driving \_\_\_\_ miles or \_\_\_\_ minutes

### IV. WHAT TYPE OF NOISE

- Squeak (like tennis shoes on a clean floor)
- Creak (like walking on an old wooden floor)
- Rattle (like shaking a baby rattle)
- Knock (like a knock at the door)
- Tick (like a clock second hand)
- Thump (heavy muffled knock noise)
- Buzz (like a bumble bee)

### TO BE COMPLETED BY DEALERSHIP PERSONNEL

Test Drive Notes:

---

---

---

	YES	NO	Initials of person performing
Vehicle test driven with customer	<input type="checkbox"/>	<input type="checkbox"/>	_____
- Noise verified on test drive	<input type="checkbox"/>	<input type="checkbox"/>	_____
- Noise source located and repaired	<input type="checkbox"/>	<input type="checkbox"/>	_____
- Follow up test drive performed to confirm repair	<input type="checkbox"/>	<input type="checkbox"/>	_____

VIN: \_\_\_\_\_ Customer Name \_\_\_\_\_

W.O.# \_\_\_\_\_ Date: \_\_\_\_\_

This form must be attached to Work Order

LATA0071E

A  
B  
C  
D  
E  
F  
G  
H  
I  
SE  
K  
L  
M  
N  
O  
P

# PRECAUTIONS

< PRECAUTION >

## PRECAUTION

### PRECAUTIONS

#### Precaution for Supplemental Restraint System (SRS) "AIR BAG" and "SEAT BELT PRE-TENSIONER"

INFOID:000000007360057

The Supplemental Restraint System such as "AIR BAG" and "SEAT BELT PRE-TENSIONER", used along with a front seat belt, helps to reduce the risk or severity of injury to the driver and front passenger for certain types of collision. This system includes seat belt switch inputs and dual stage front air bag modules. The SRS system uses the seat belt switches to determine the front air bag deployment, and may only deploy one front air bag, depending on the severity of a collision and whether the front occupants are belted or unbelted. Information necessary to service the system safely is included in the SR and SB section of this Service Manual.

#### **WARNING:**

- To avoid rendering the SRS inoperative, which could increase the risk of personal injury or death in the event of a collision which would result in air bag inflation, all maintenance must be performed by an authorized NISSAN/INFINITI dealer.
- Improper maintenance, including incorrect removal and installation of the SRS, can lead to personal injury caused by unintentional activation of the system. For removal of Spiral Cable and Air Bag Module, see the SR section.
- Do not use electrical test equipment on any circuit related to the SRS unless instructed to in this Service Manual. SRS wiring harnesses can be identified by yellow and/or orange harnesses or harness connectors.

#### PRECAUTIONS WHEN USING POWER TOOLS (AIR OR ELECTRIC) AND HAMMERS

#### **WARNING:**

- When working near the Airbag Diagnosis Sensor Unit or other Airbag System sensors with the Ignition ON or engine running, DO NOT use air or electric power tools or strike near the sensor(s) with a hammer. Heavy vibration could activate the sensor(s) and deploy the air bag(s), possibly causing serious injury.
- When using air or electric power tools or hammers, always switch the Ignition OFF, disconnect the battery, and wait at least 3 minutes before performing any service.

#### Precaution for Work

INFOID:000000007360058

- When removing or disassembling each component, be careful not to damage or deform it. If a component may be subject to interference, be sure to protect it with a shop cloth.
- When removing (disengaging) components with a screwdriver or similar tool, be sure to wrap the component with a shop cloth or vinyl tape to protect it.
- Protect the removed parts with a shop cloth and prevent them from being dropped.
- Replace a deformed or damaged clip.
- If a part is specified as a non-reusable part, always replace it with new one.
- Be sure to tighten bolts and nuts securely to the specified torque.
- After installation is complete, be sure to check that each part works properly.
- Follow the steps below to clean components.
  - Water soluble dirt: Dip a soft cloth into lukewarm water, and wring the water out of the cloth to wipe the dirty area.  
Then rub with a soft and dry cloth.
  - Oily dirt: Dip a soft cloth into lukewarm water with mild detergent (concentration: within 2 to 3%), and wipe the dirty area.  
Then dip a cloth into fresh water, and wring the water out of the cloth to wipe the detergent off. Then rub with a soft and dry cloth.
- Do not use organic solvent such as thinner, benzene, alcohol, or gasoline.
- For genuine leather seats, use a genuine leather seat cleaner.



# PREPARATION

< PREPARATION >

## PREPARATION

### PREPARATION

#### Special Service Tool

INFOID:000000007360059

The actual shapes of Kent-Moore tools may differ from those of special service tools illustrated here.

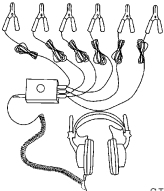
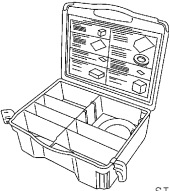
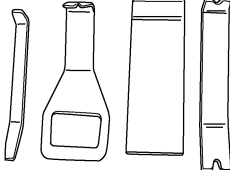
Tool number (Kent-Moore No.) Tool name	Description
— (J-39570) Chassis ear   SIIA0993E	Locating the noise
— (J-43980) NISSAN Squeak and Rattle Kit   SIIA0994E	Repairing the cause of noise
— (J-46534) Trim Tool Set   AWJIA0483ZZ	Removing trim components

#### Commercial Service Tool

INFOID:000000007360060

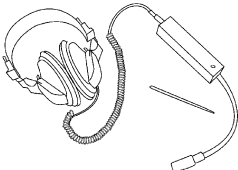
(Kent-Moore No.) Tool name	Description
(J-39565) Engine ear   SIIA0995E	Locating the noise

# CLIP LIST







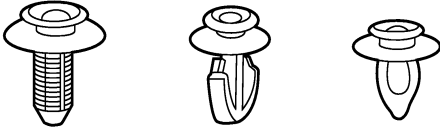

< PREPARATION >

## CLIP LIST

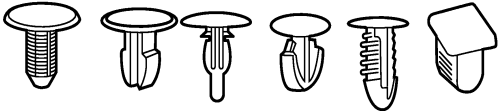
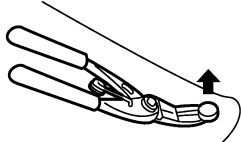
Descriptions for Clips

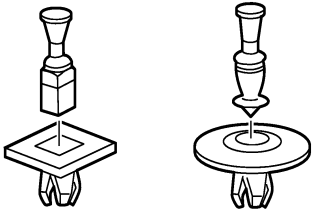
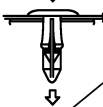
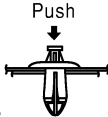
INFOID:000000007837888

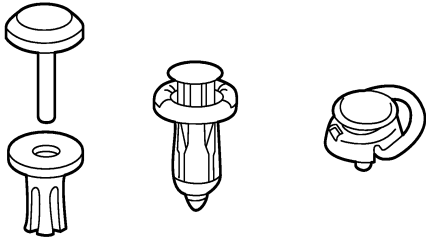
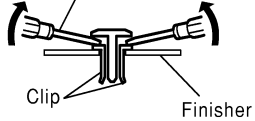

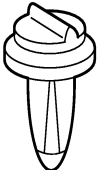
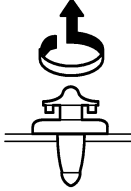





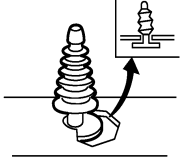
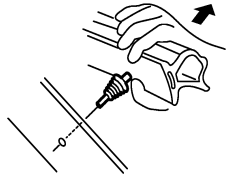

Replace any clips which are damaged during removal or installation.

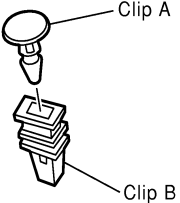
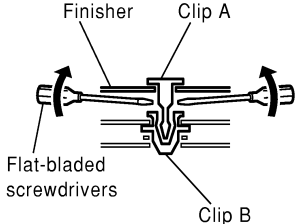
Symbol No.	Shapes	Removal & Installation
<p>C101</p> 		<p><b>Removal:</b> Remove by bending up with flat-bladed screwdrivers or clip remover.</p> 
<p>C103</p> 		 <p><b>Removal:</b> Remove with a clip remover.</p>
<p>C203</p> 		<p><b>Removal:</b> Push center pin to catching position. (Do not remove center pin by hitting it.)</p> <p>Push</p>  <p><b>Installation:</b></p> 
<p>C205</p> 		<p><b>Removal:</b></p>  <p>Flat-bladed screwdriver</p> <p>Clip</p> <p>Finisher</p>
<p>C206</p> 		<p><b>Removal:</b></p> 

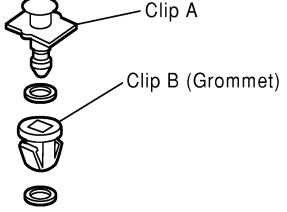
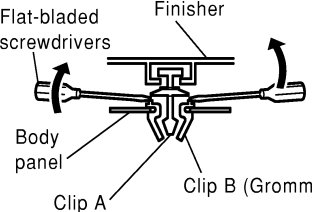
S1IA0315E

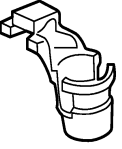
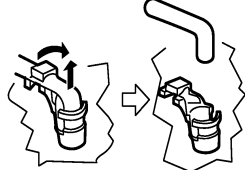
# CLIP LIST

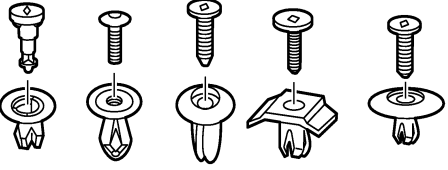
## < PREPARATION >









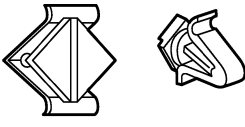

Symbol No.	Shapes	Removal & Installation
CE103 		<b>Removal:</b> 
CF110 		<b>Removal:</b> 
CF118 		<b>Removal:</b> 
CR103 		<b>Removal:</b> Holder portion of clip must be spread out to remove rod. 
CS101 		<b>Removal:</b> 1. Screw out with a Phillips screwdriver. 2. Remove female portion with flat-bladed screwdriver. 

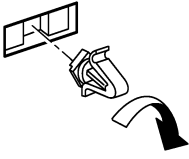
SIIA0316E

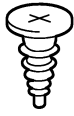
A  
B  
C  
D  
E  
F  
G  
H  
I  
SE  
K  
L  
M  
N  
O  
P

# CLIP LIST

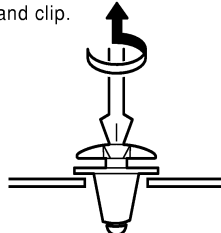

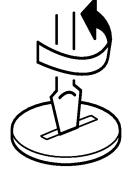
## < PREPARATION >

Symbol No.	Shapes	Removal & Installation	
CG101 		<b>Removal:</b>  Rotate 45° to remove	<b>Installation:</b> 
CS102 			
CS113 		<b>Removal:</b> Disconnect upper connection of clip with a flat-bladed screwdriver, then remove clip while inserting a flat-bladed screwdriver between body panel and clip. 	
C111 			

S1IA0317E

# CLIP LIST

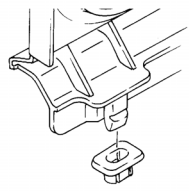
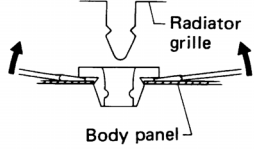
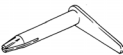
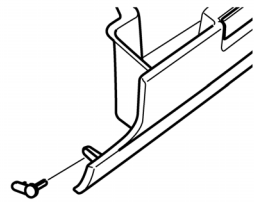
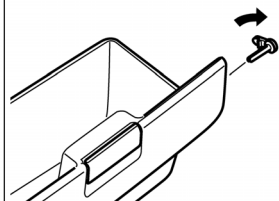
< PREPARATION >

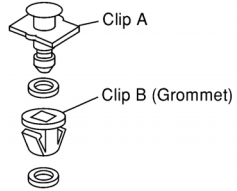
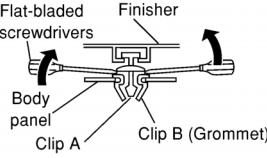
Symbol No.	Shapes	Removal & Installation
<p>CG104</p> 		<p><b>Removal:</b> Remove by bending up with flat-bladed screwdrivers.</p> 
<p>CE114</p> 		
<p>CF118</p> 		<p><b>Removal:</b> Flat-bladed screwdrivers Finisher</p> 

ALJIA0564GB

A  
B  
C  
D  
E  
F  
G  
H  
I

SE

K  
L  
M  
N  
O  
P

# FRONT SEAT

< REMOVAL AND INSTALLATION >

## REMOVAL AND INSTALLATION

### FRONT SEAT

Component

INFOID:000000007360061

Driver Seat

SEC. 870

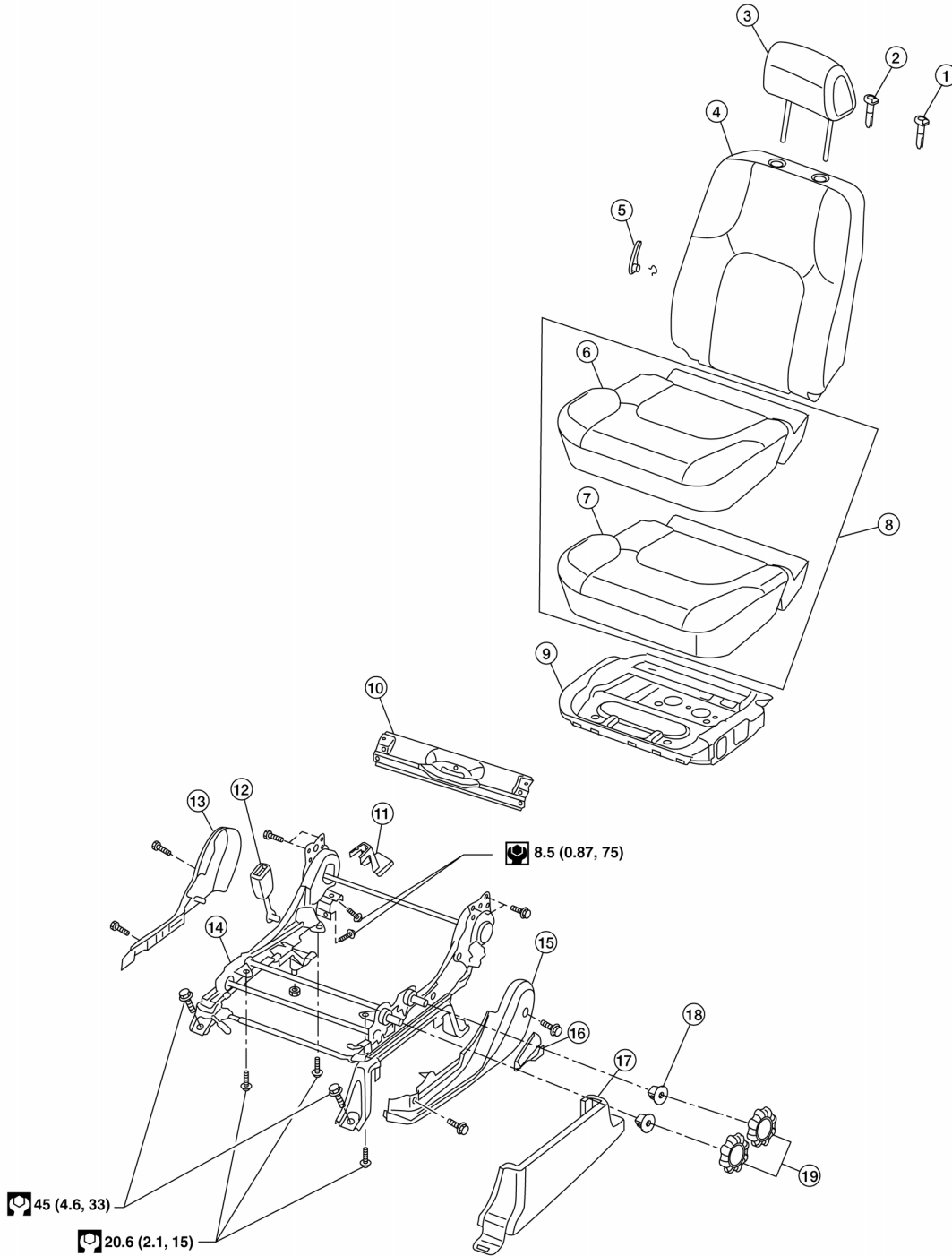

AWJIA0555GB

# FRONT SEAT

## < REMOVAL AND INSTALLATION >

---

1. Locking headrest guide	2. Headrest guide	3. Headrest	A
4. Seatback assembly with side air bag	5. Lumbar support lever (if equipped)	6. Seat cushion trim	
7. Seat cushion pad	8. Seat cushion assembly	9. Seat cushion frame	
10. Seat cushion rear finisher	11. Leg cover	12. Seat belt buckle	B
13. Seat cushion inner finisher	14. Driver seat slide assembly	15. Seat cushion outer finisher	
16. Seatback recline release lever	17. Outer pedestal finisher	18. Seat cushion adjusting knob clips (if equipped)	C
19. Seat cushion adjusting knobs (if equipped)			D
			E
			F
			G
			H
			I
			<b>SE</b>
			K
			L
			M
			N
			O
			P

# FRONT SEAT

## < REMOVAL AND INSTALLATION >

### Passenger Seat

SEC. 870

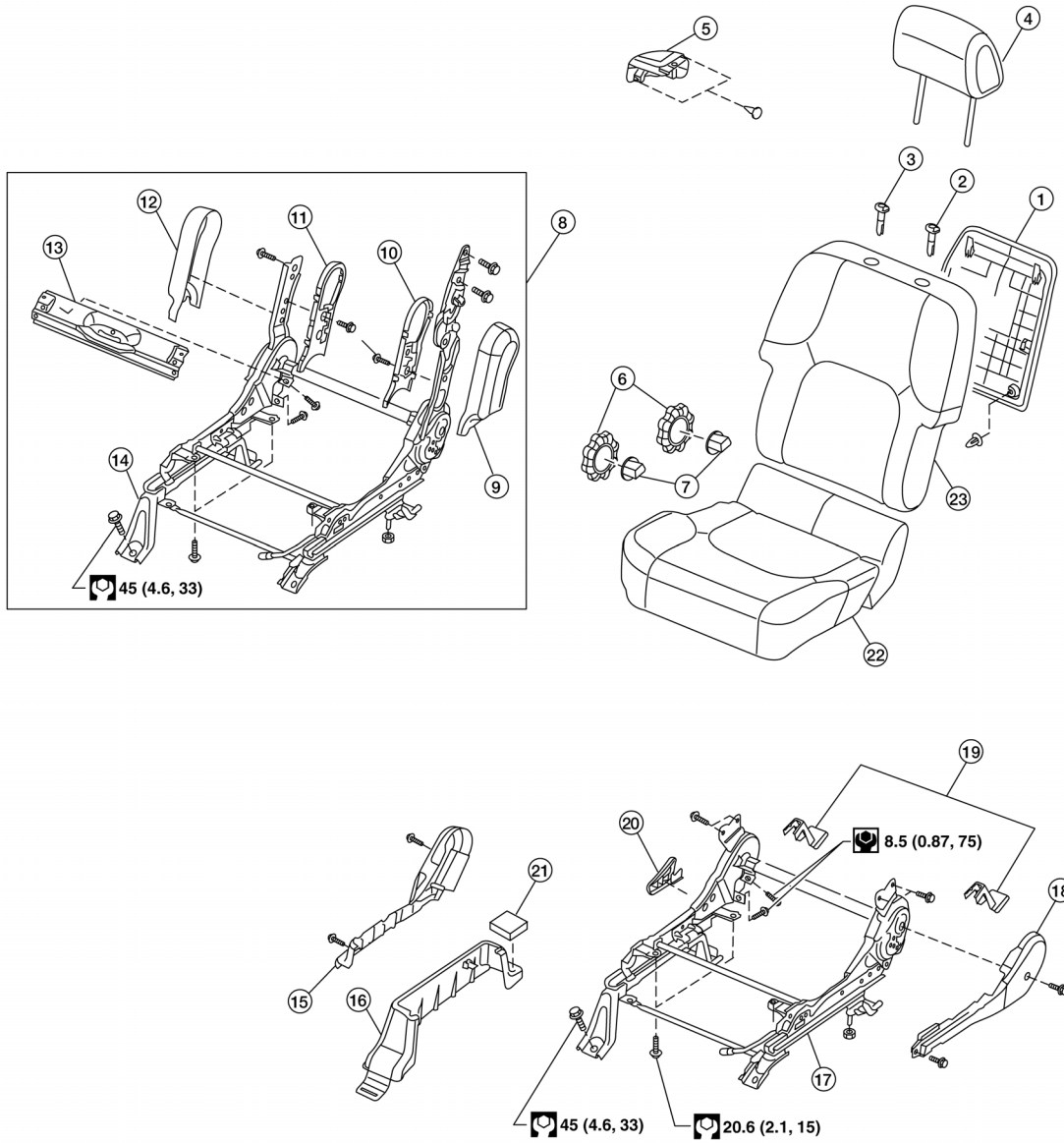

SEC. 870

AWJIA0558GB



# FRONT SEAT

## < REMOVAL AND INSTALLATION >

- |                                       |   |  |   |
|---------------------------------------|---|--|---|
| 1. Seatback board                     | 2. Locking headrest guide               | 3. Headrest guide                      | A |
| 4. Headrest                           | 5. Front seatback lever (if equipped)   | 6. Adjuster knobs (if equipped)        |   |
| 7. Clips                              | 8. Fold flat seat frame slide assembly  | 9. Inboard reclining arm outer cover   |   |
| 10. Inboard reclining arm inner cover | 11. Outboard reclining arm inner cover  | 12. Outboard reclining arm outer cover | B |
| 13. Seat cushion rear finisher        | 14. Fold flat seat frame                | 15. Seat cushion outer finisher        |   |
| 16. Outer pedestal finisher           | 17. Manual seat frame slide assembly    | 18. Seat cushion inner cover           |   |
| 19. Leg cover                         | 20. Recline release lever               | 21. Bolt cap                           | C |
| 22. Seat cushion assembly             | 23. Seatback assembly with side air bag |  |   |

## Removal and Installation

INFOID:000000007360062

### SEAT ASSEMBLY

#### Removal

#### **CAUTION:**

- Before removing the front seat, turn the ignition switch off, disconnect both battery terminals and wait at least three minutes.
- Do not drop, tilt, or bump the side air bag module while installing the seat. Always handle it with care.
- After front side air bag module inflates, front seatback assembly must be replaced.
- Front passenger seat is equipped with an Occupant Classification System sensor and control module. Do not disassemble front passenger seat cushion assembly or remove the trim as this will affect the Occupant Classification System calibration.
- Always replace passenger seat cushion as an assembly.

1. Position the seat until the three seat bolts and one nut are visible and a suitable tool can be inserted.

#### **NOTE:**

- If disassembling the seat after removal, set the front/rear cushion lifters to the top position (if equipped).
2. Disconnect the battery negative and positive terminals and wait at least three minutes.
  3. Remove the three seat bolts and one nut.
  4. Disconnect the seat harness connectors.
  5. Remove the seat assembly from the vehicle.

#### **CAUTION:**

**When removing and installing the seat, use shop cloths to protect the vehicle from damage.**

#### Installation

Installation is in the reverse order of removal.

### SEATBACK ASSEMBLY - DRIVER'S SEAT

#### Removal

1. Remove the driver's seat assembly.

# FRONT SEAT

## < REMOVAL AND INSTALLATION >

2. The seatback cover is attached with the following:

- Unzip the seatback trim flap (1)
- Unclip the lower retainer (2)

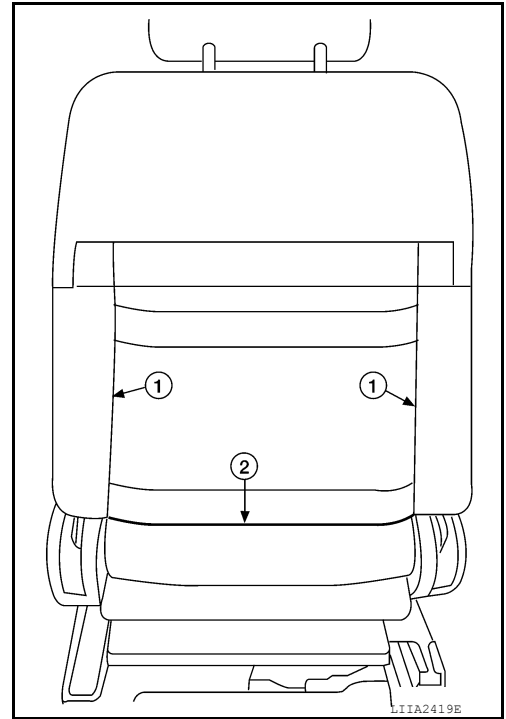

3. Remove the four seatback bolts (two for each side) and the seatback assembly.

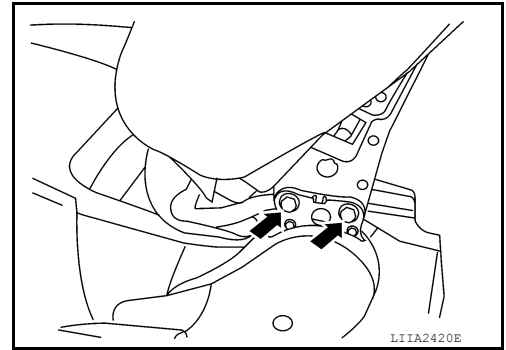

### Installation

Installation is in the reverse order of removal.

## SEATBACK ASSEMBLY - PASSENGER'S SEAT, WITH SOFT SEATBACK

### Removal

1. Remove the passenger seat assembly.
2. The seatback board is attached to the seat frame with the following:
  - Two top tabs (A)
  - Two side tabs (B)
  - Two bottom clips (C) (must be replaced)
3. Move seat to forward position.

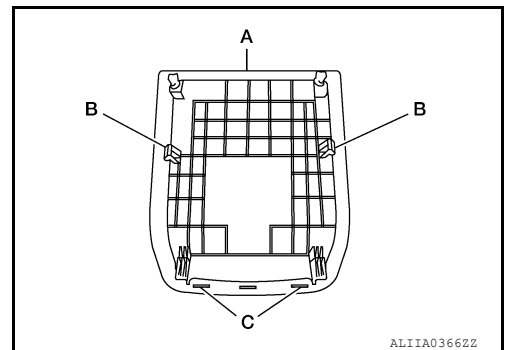

## FRONT SEAT

### < REMOVAL AND INSTALLATION >

4. Hold the seatback board as shown and pull the top of the seatback board away from the seatback frame.

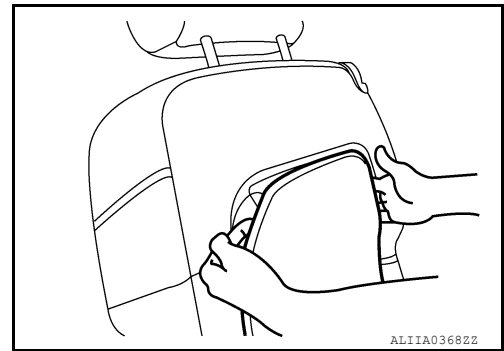

5. Pull the middle part of the seatback board to disengage the side tabs from the seatback frame.

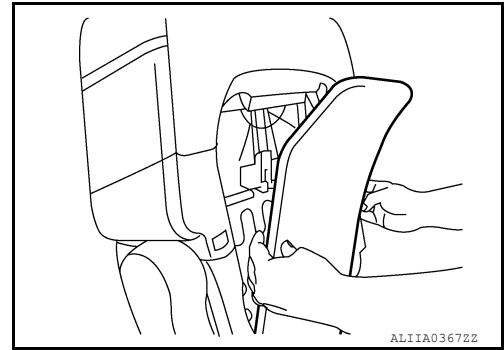

6. Pull the lower part of the seatback board to disengage the bottom clips from the seatback frame.

7. Remove the bolts (two for each side) and the seatback assembly.

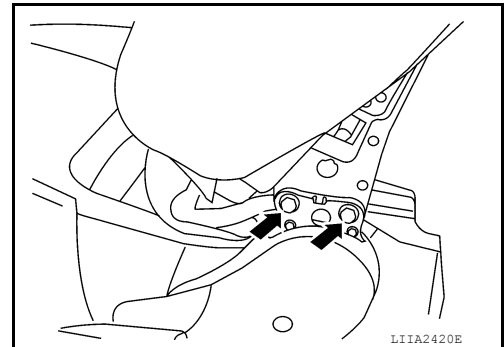

#### Installation

Installation is in the reverse order of removal.

### SEATBACK ASSEMBLY - PASSENGER'S SEAT, WITH HARD SEATBACK

#### Removal

1. Remove the passenger seat assembly.
2. The seatback board is attached to the seat frame with the following:
  - Two top tabs (A)
  - Two side tabs (B)
  - Two bottom clips (C) (must be replaced)
3. Move seat to forward position.

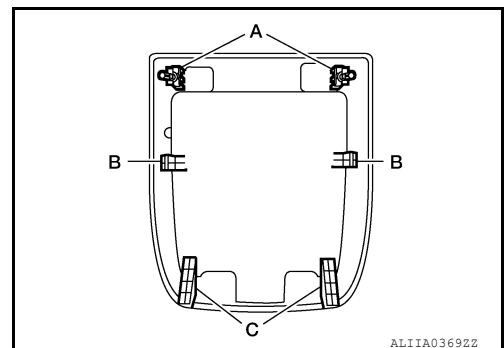

## FRONT SEAT

### < REMOVAL AND INSTALLATION >

4. Hold the seatback board as shown and pull the bottom of the seatback board away from the seatback frame.

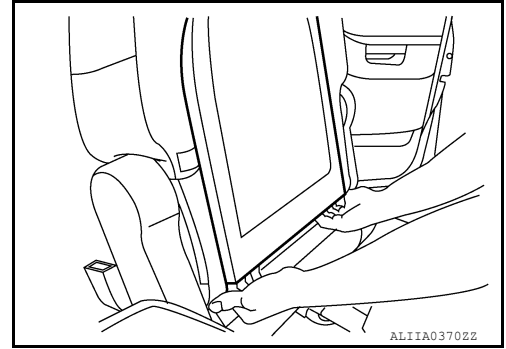

5. Pull the middle part of the seatback board to disengage the side tabs from the seatback frame.

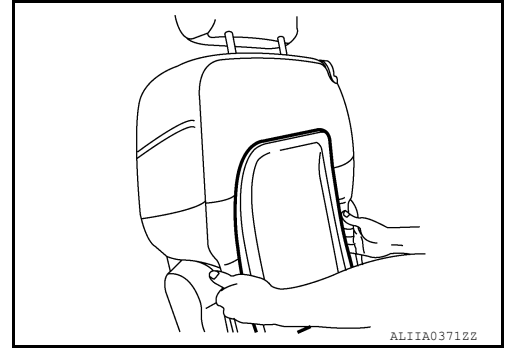

6. Lift the upper part of the seatback board to disengage the top tabs from the seatback frame.

7. Remove the bolts (two for each side) and the seatback assembly.

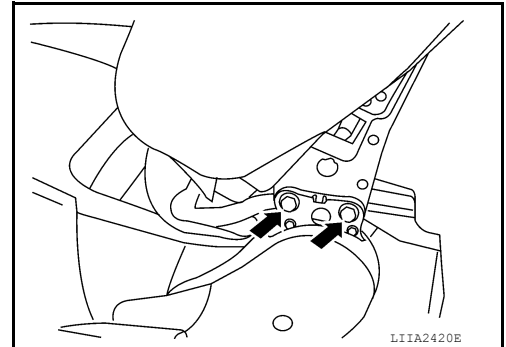

### Installation

Installation is in the reverse order of removal.

### SEATBACK ASSEMBLY - PASSENGER'S FOLD FLAT SEAT

#### Removal

1. Remove the passenger seat assembly.
2. The seatback board is attached to the seat frame with the following:
  - Two top tabs (A)
  - Two side tabs (B)
  - Two bottom clips (C) (must be replaced)
3. Move seat to forward position.

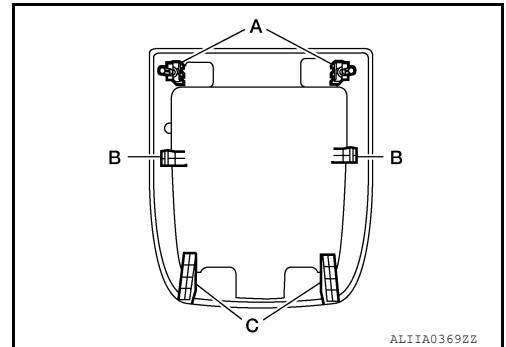

# FRONT SEAT

## < REMOVAL AND INSTALLATION >

4. Hold the seatback board as shown and pull the bottom of the seatback board away from the seatback frame.

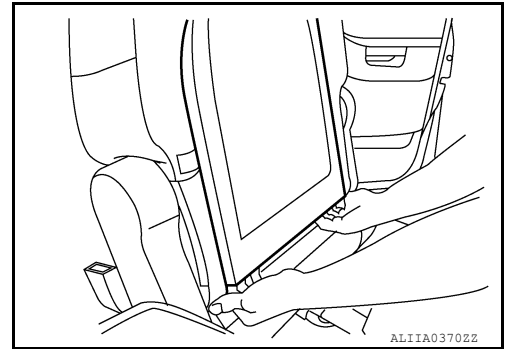

5. Pull the middle part of the seatback board to disengage the side tabs from the seatback frame.

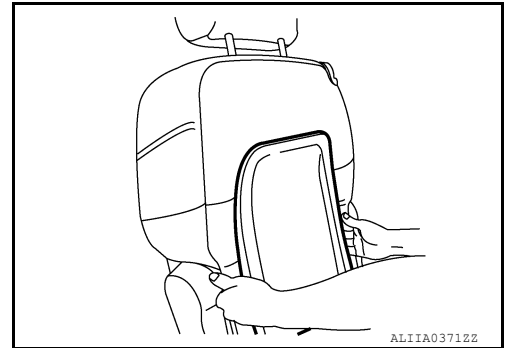

6. Lift the upper part of the seatback board to disengage the top tabs from the seatback frame.
7. Remove the seat cushion outer finisher and seat cushion inner finisher.
8. Remove the three seatback assembly bolts and the seatback assembly.

### Installation

Installation is in the reverse order of removal.

## SEAT CUSHION ASSEMBLY

### Removal

#### **CAUTION:**

- Front passenger seat is equipped with an Occupant Classification System sensor and control module. Do not disassemble front passenger seat cushion assembly or remove the trim as this will affect the Occupant Classification System calibration.
- Always replace passenger seat cushion as an assembly.
- When removed, the passenger seat cushion must always be placed pan side UP to prevent damage.
- During installation, the wire harness clips must be reinstalled in the holes they were originally in. Do not add additional clips.
- The Occupant Classification System control module can only be replaced as part of the seat cushion assembly.

1. Remove the seat assembly.
2. Remove the recline release lever.
3. Remove four bolts and the seat cushion assembly.
  - On the fold flat passenger seat it is necessary to unclip the rear flap j-clip from the seat pan.

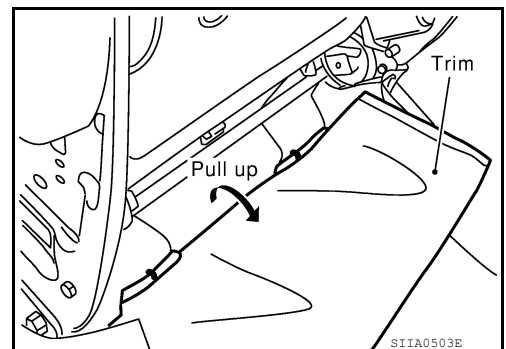

## FRONT SEAT

### < REMOVAL AND INSTALLATION >

---

#### Installation

Installation is in the reverse order of removal.

# REAR SEAT

< REMOVAL AND INSTALLATION >

## REAR SEAT

### Removal and Installation

INFOID:000000007360063

#### SEAT CUSHION ASSEMBLY

##### Removal

1. Tilt seat cushion (3) forward (1).
2. Lift cushion lock handles (2).
3. Remove seat cushion assembly

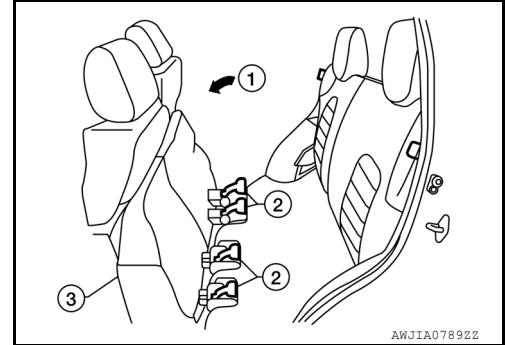

##### Installation

Installation is in the reverse order of removal.

#### SEATBACK ASSEMBLY

##### Removal

1. Remove the luggage floor storage tray. Refer to [INT-24, "Removal and Installation"](#).
2. Tilt the seat cushion forward.
3. Remove the seat belt buckle bolt, seatback bolts and seatback-assembly.

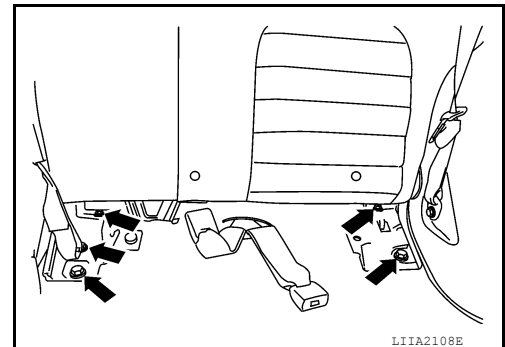

##### Installation

Installation is in the reverse order of removal.

**Seatback bolts : 45 N·m (4.6 kg·m, 33 ft·lb)**

A  
B  
C  
D  
E  
F  
G  
H  
I  
SE  
K  
L  
M  
N  
O  
P

# FRONT SEAT

< UNIT DISASSEMBLY AND ASSEMBLY >

## UNIT DISASSEMBLY AND ASSEMBLY

### FRONT SEAT

Component

INFOID:000000007360064

Driver Seat

SEC. 870

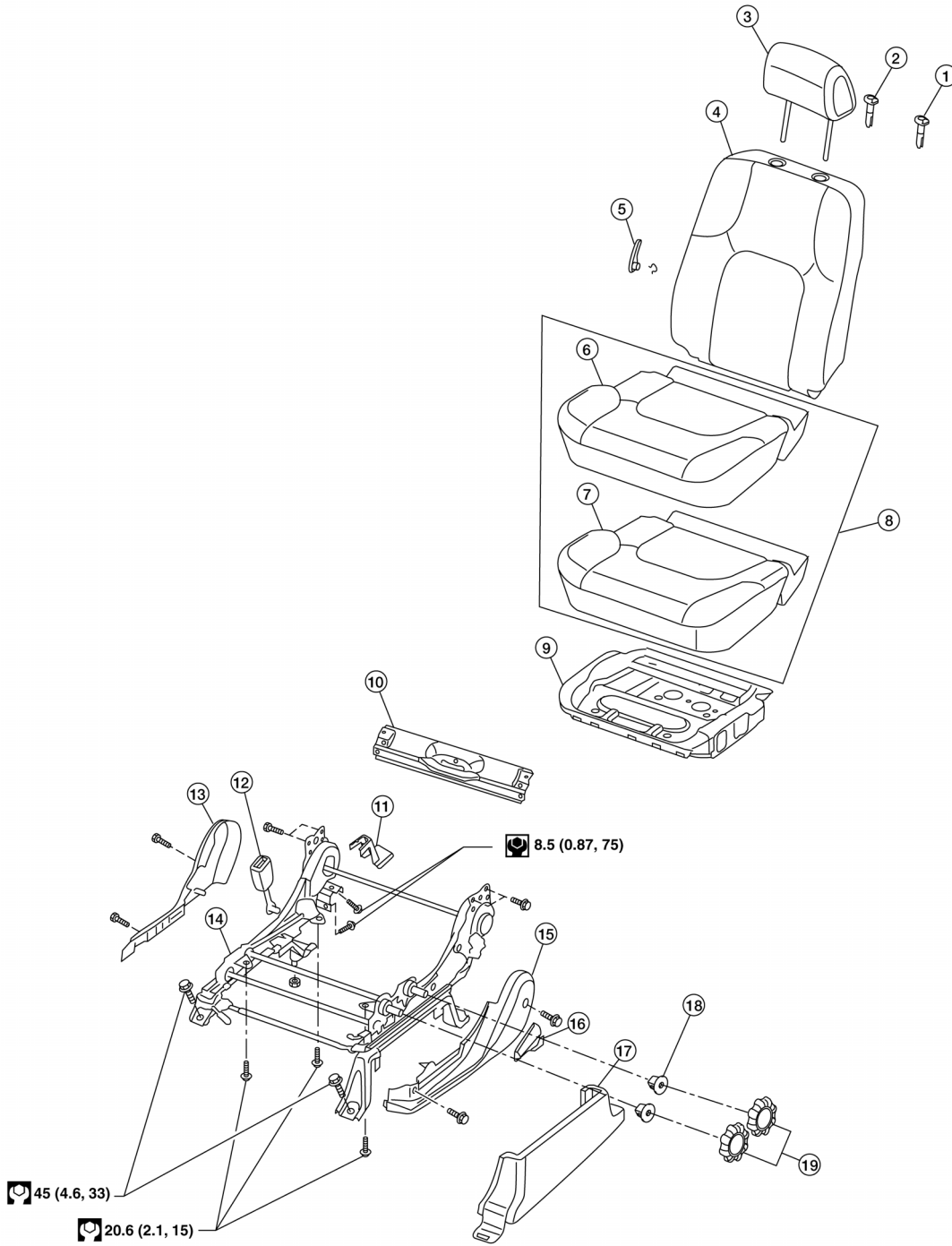

AWJIA0555GB



# FRONT SEAT

## < UNIT DISASSEMBLY AND ASSEMBLY >

---

1. Locking headrest guide	2. Headrest guide	3. Headrest	A
4. Seatback assembly with side air bag	5. Lumbar support lever (if equipped)	6. Seat cushion trim	
7. Seat cushion pad	8. Seat cushion assembly	9. Seat cushion frame	
10. Seat cushion rear finisher	11. Leg cover	12. Seat belt buckle	B
13. Seat cushion inner finisher	14. Driver seat slide assembly	15. Seat cushion outer finisher	
16. Seatback recline release lever	17. Outer pedestal finisher	18. Seat cushion adjusting knob clips (if equipped)	C
19. Seat cushion adjusting knobs (if equipped)			D
			E
			F
			G
			H
			I
			<b>SE</b>
			K
			L
			M
			N
			O
			P

# FRONT SEAT

## < UNIT DISASSEMBLY AND ASSEMBLY >

### Passenger Seat

SEC. 870

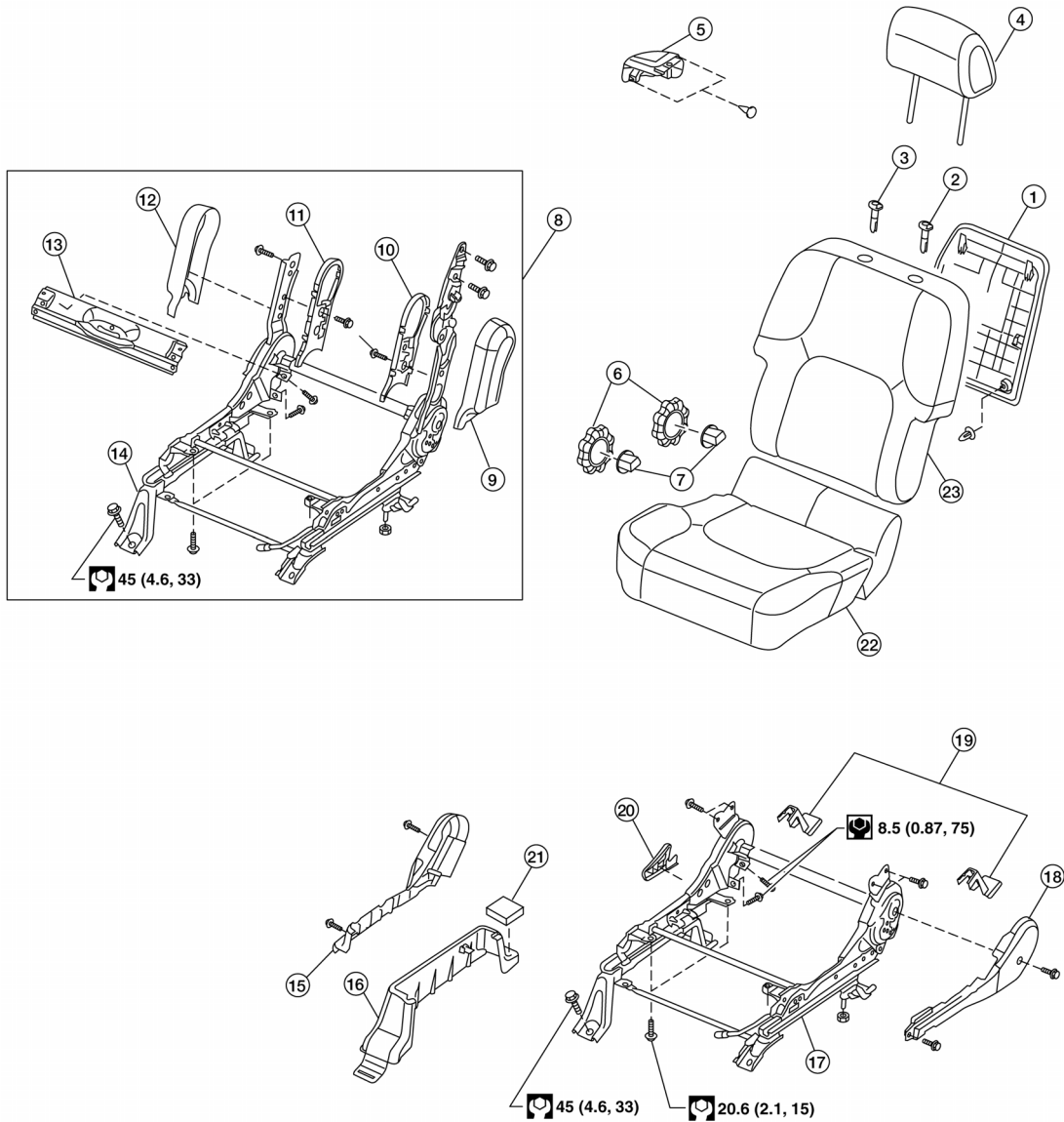

AWJIA0558GB

- |  |   |   |
|--|---|---|
| 1. Seatback board                        | 2. Locking headrest guide                 | 3. Headrest guide                         |
| 4. Headrest                              | 5. Front seatback lever (if equipped)     | 6. Adjuster knobs (if equipped)           |
| 7. Clips                                 | 8. Fold flat seat frame slide assembly    | 9. Inboard reclining arm outer finisher   |
| 10. Inboard reclining arm inner finisher | 11. Outboard reclining arm inner finisher | 12. Outboard reclining arm outer finisher |
| 13. Seat cushion rear finisher           | 14. Fold flat seat frame                  | 15. Seat cushion outer finisher           |
| 16. Outer pedestal finisher              | 17. Manual seat frame slide assembly      | 18. Seat cushion inner finisher           |

# FRONT SEAT

## < UNIT DISASSEMBLY AND ASSEMBLY >

- |                           |                           |   |
|---------------------------|---------------------------|---|
| 19. Leg cover             | 20. Recline release lever | 21. Bolt cap                            |
| 22. Seat cushion assembly | 20. Recline release lever | 21. Seatback assembly with side air bag |

## Disassembly and Assembly

INFOID:000000007360065

### SEATBACK

#### Disassembly

#### **CAUTION:**

- Only complete seatback assemblies can be replaced.
- When removing or installing the seat trim, handle it carefully to keep dirt out and avoid damage.

1. Remove the seatback assembly. Refer to [SE-17, "Removal and Installation"](#).
2. Remove the headrest.
3. From inside of the seatback, squeeze the headrest holder tabs at the base of the stay pipe and pull upward to remove.

#### **NOTE:**

Before installing the headrest holder, check its orientation (front/rear and right/left).

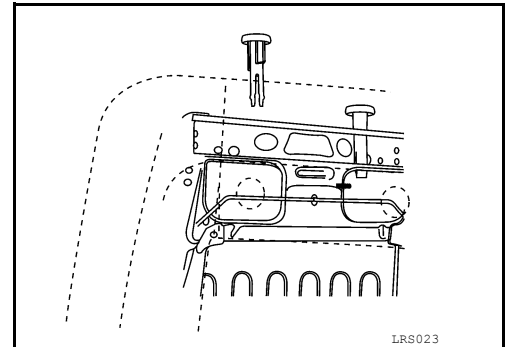

4. Remove the snap ring and the lumbar support lever knob (if equipped).

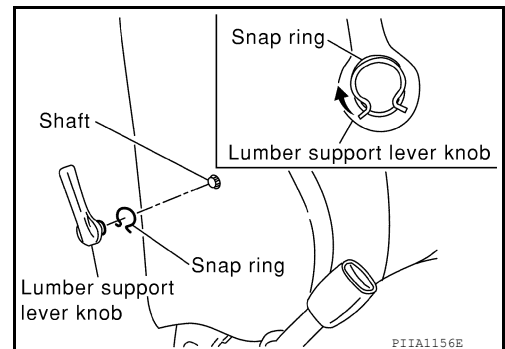

#### Assembly

Assembly is in the reverse order of disassembly.

### SEAT CUSHION TRIM AND PAD

#### Disassembly

#### **CAUTION:**

- Front passenger seat is equipped with an Occupant Classification System sensor and control module. Do not disassemble front passenger seat cushion assembly or remove the trim as this will affect the Occupant Classification System calibration.
- Always replace passenger seat cushion as an assembly.
- When removed, the passenger seat cushion must always be placed pan side UP to prevent damage.
- During installation, the wire harness clips must be reinstalled in the holes they were originally in. Do not add additional clips.
- The Occupant Classification System control module can only be replaced as part of the seat cushion assembly.

1. Remove the recline release lever.
2. Remove four seat cushion bolts and the seat cushion assembly.
3. On the drivers seat only, remove the seat cushion trim and pad.
4. On the drivers seat only, remove the hog rings to separate the trim cover from the pad.

#### Assembly

## FRONT SEAT

### < UNIT DISASSEMBLY AND ASSEMBLY >

Assembly is in the reverse order of disassembly.

#### PASSENGER SEATBACK BOARD - SOFT SEATBACK

##### Removal

1. The seatback board is attached to the seat frame with the following:
  - Two top tabs (A)
  - Two side tabs (B)
  - Two bottom clips (C) (must be replaced)
2. Move seat to forward position.

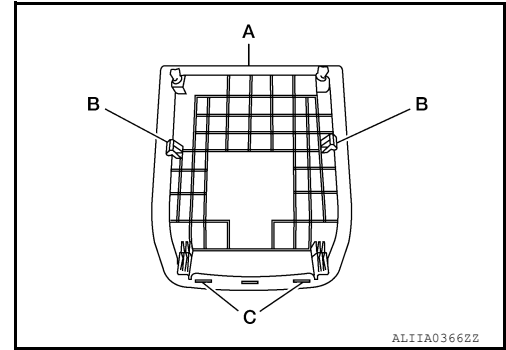

3. Hold the seatback board as shown and pull the top of the seatback board down and away from the seatback frame.

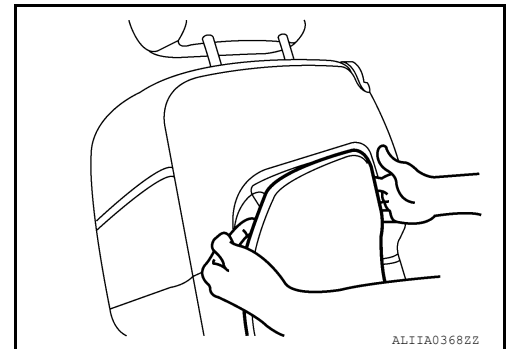

4. Pull the middle part of the seatback board to disengage the side tabs from the seatback frame.
5. Pull the lower part of the seatback board to disengage the bottom clips from the seatback frame.

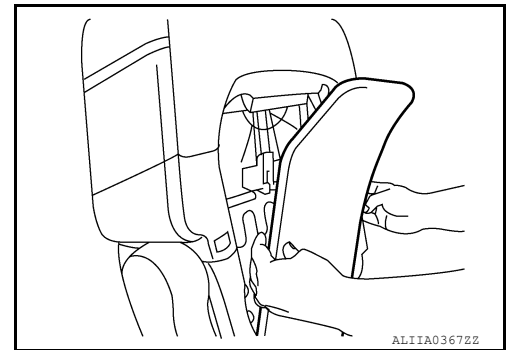

##### Installation

Installation is in the reverse order of removal.

- The two bottom clips must be replaced for installation
- Secure the side tabs last for installation

#### PASSENGER SEATBACK BOARD - HARD SEATBACK

##### Removal

# FRONT SEAT

## < UNIT DISASSEMBLY AND ASSEMBLY >

1. The seatback board is attached to the seat frame with the following:
  - Two top tabs (A)
  - Two side tabs (B)
  - Two bottom clips (C) (must be replaced)
2. Move seat to forward position.

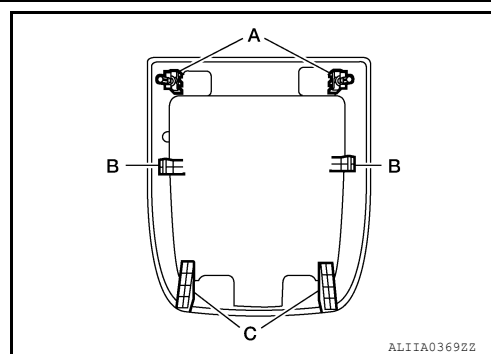

3. Hold the seatback board as shown and pull the bottom of the seatback board away from the seatback frame.

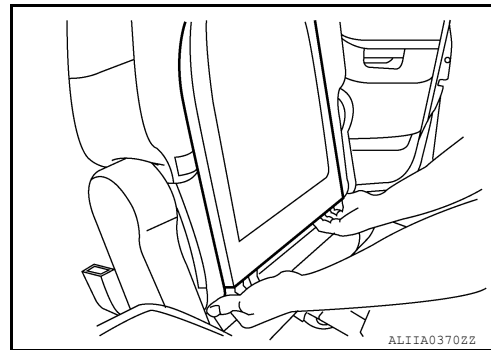

4. Pull the middle part of the seatback board up and away to disengage the side tabs from the seatback frame.

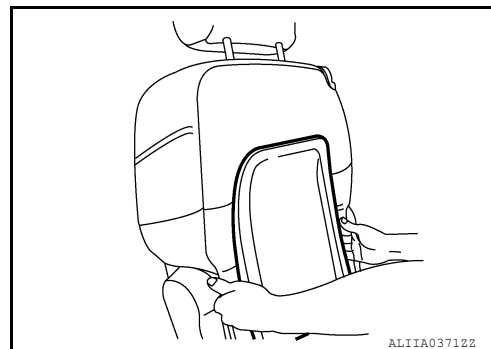

5. Lift the upper part of the seatback board to disengage the top tabs from the seatback frame.

### Installation

Installation is in the reverse order of removal.

- The two bottom clips must be replaced for installation
- Secure the side tabs last for installation

A  
B  
C  
D  
E  
F  
G  
H  
I  
SE  
K  
L  
M  
N  
O  
P

# REAR SEAT

< UNIT DISASSEMBLY AND ASSEMBLY >

## REAR SEAT

### Disassembly and Assembly

INFOID:000000007360066

LH

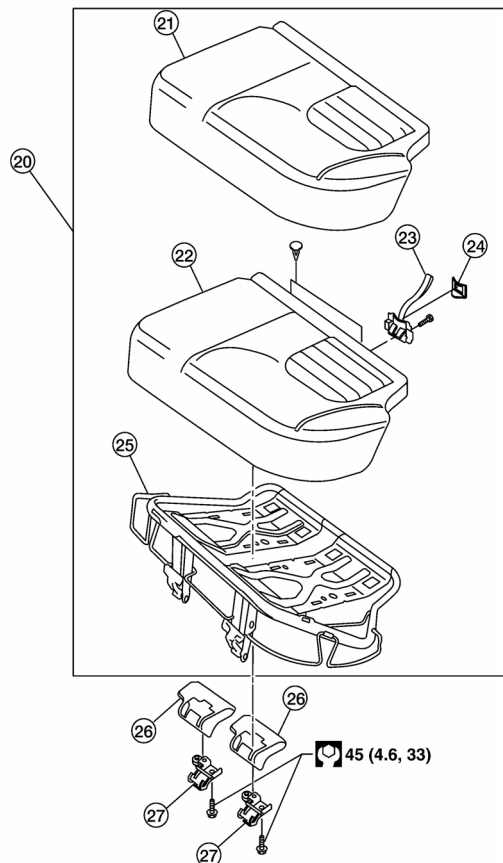
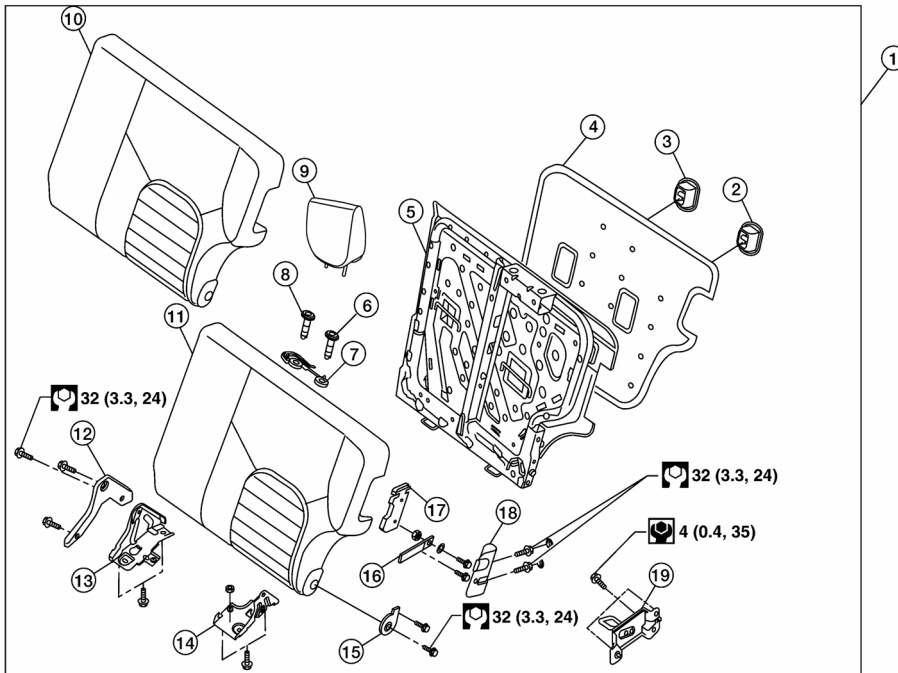

AWJIA0790GB

- 1. Seatback assembly
- 4. Seatback board

- 2. Tie down hook outboard
- 5. Seatback frame assembly

- 3. Tie down hook inboard
- 6. Locking headrest guide

# REAR SEAT

## < UNIT DISASSEMBLY AND ASSEMBLY >

---

- |                                 |                              |                          |   |
|---------------------------------|------------------------------|--------------------------|---|
| 7. Seat belt comfort guide      | 8. Headrest guide            | 9. Headrest              | A |
| 10. Seatback trim               | 11. Seatback pad             | 12. Inboard hinge cover  |   |
| 13. Inboard hinge bracket       | 14. Outboard hinge bracket   | 15. Outboard pivot cover |   |
| 16. Seatback release strap      | 17. Seatback latch assembly  | 18. Seatback latch cover | B |
| 19. Seatback striker            | 20. Seat cushion assembly    | 21. Seat cushion trim    |   |
| 22. Seat cushion pad            | 23. Rear seat assembly lock  | 24. Rear seat lock cover |   |
| 25. Seat cushion frame assembly | 26. Seat cushion pivot cover | 27. Seat cushion pivot   | C |

D

E

F

G

H

I

**SE**

K

L

M

N

O

P

# REAR SEAT

< UNIT DISASSEMBLY AND ASSEMBLY >

RH

SEC. 880

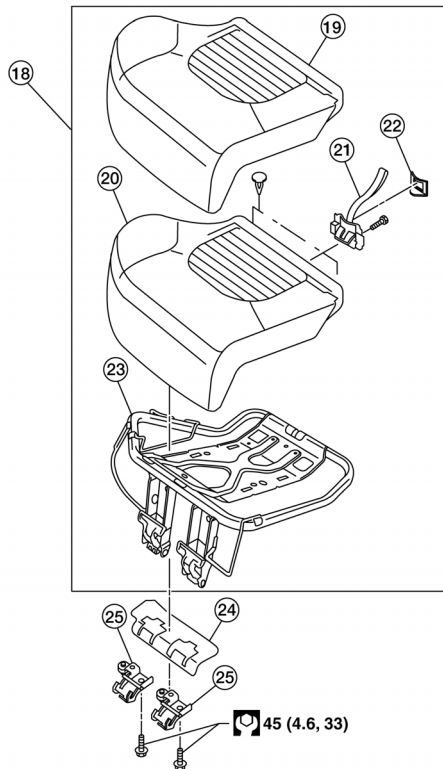
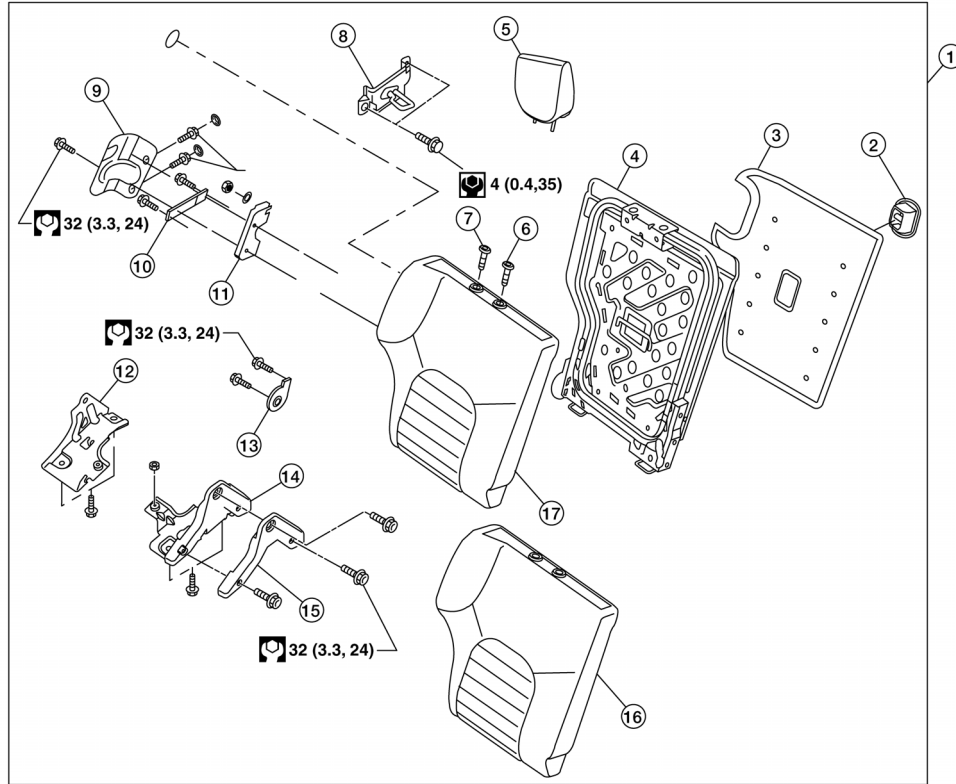

AWJIA0791GB

- |                            |                             |                            |
|----------------------------|-----------------------------|----------------------------|
| 1. Seatback assembly       | 2. Tie down hook            | 3. Seatback board          |
| 4. Seatback frame assembly | 5. Headrest                 | 6. Locking headrest guide  |
| 7. Headrest guide          | 8. Seatback striker         | 9. Seatback latch cover    |
| 10. Seatback release strap | 11. Seatback latch assembly | 12. Outboard hinge bracket |
| 13. Outboard pivot cover   | 14. Inboard hinge bracket   | 15. Inboard hinge cover    |
| 16. Seatback trim          | 17. Seatback pad            | 18. Seat cushion assembly  |



# REAR SEAT

## < UNIT DISASSEMBLY AND ASSEMBLY >

---

- |                          |                                 |                              |
|--------------------------|---------------------------------|------------------------------|
| 19. Seat cushion trim    | 20. Seat cushion pad            | 21. Rear seat lock assembly  |
| 22. Rear seat lock cover | 23. Seat cushion frame assembly | 24. Seat cushion pivot cover |
| 25. Seat cushion pivot   |                                 |                              |

A

B

C

D

E

F

G

H

I

**SE**

K

L

M

N

O

P