

SECTION **DEF**
DEFOGGER

A
B
C
D
E
F
G
H
I
J
K
DEF
M
N
O
P

CONTENTS

| | | | |
|--|----|---|----|
| BASIC INSPECTION | 3 | Description | 12 |
| DIAGNOSIS AND REPAIR WORKFLOW | 3 | Component Function Check | 12 |
| Repair Work Flow | 3 | Diagnosis Procedure | 12 |
| SYSTEM DESCRIPTION | 4 | Component Inspection | 14 |
| REAR WINDOW DEFOGGER SYSTEM | 4 | DOOR MIRROR DEFOGGER RH | 15 |
| System Diagram | 4 | Description | 15 |
| System Description | 4 | Component Function Check | 15 |
| Component Parts Location | 5 | Diagnosis Procedure | 15 |
| Component Description | 5 | Component Inspection | 17 |
| DIAGNOSIS SYSTEM (BCM) | 6 | ECU DIAGNOSIS INFORMATION | 18 |
| COMMON ITEM | 6 | BCM (BODY CONTROL MODULE) | 18 |
| COMMON ITEM : CONSULT Function (BCM - | | Reference Value | 18 |
| COMMON ITEM) | 6 | Terminal Layout | 21 |
| REAR DEFOGGER | 6 | Physical Values | 21 |
| REAR DEFOGGER : CONSULT Function (BCM - | | WIRING DIAGRAM | 27 |
| REAR DEFOGGER) | 7 | REAR WINDOW DEFOGGER | 27 |
| DTC/CIRCUIT DIAGNOSIS | 8 | Wiring Diagram | 27 |
| REAR WINDOW DEFOGGER SWITCH | 8 | SYMPTOM DIAGNOSIS | 35 |
| Description | 8 | REAR WINDOW DEFOGGER AND DOOR | |
| Component Function Check | 8 | MIRROR DEFOGGER DO NOT OPERATE. | 35 |
| Diagnosis Procedure | 8 | Diagnosis Procedure | 35 |
| REAR WINDOW DEFOGGER RELAY | 9 | REAR WINDOW DEFOGGER DOES NOT | |
| Description | 9 | OPERATE BUT BOTH OF DOOR MIRROR | |
| Component Function Check | 9 | DEFOGGER OPERATE. | 36 |
| Diagnosis Procedure | 9 | Diagnosis Procedure | 36 |
| REAR WINDOW DEFOGGER POWER SUP- | | BOTH DOORS MIRROR DEFOGGER DON'T | |
| PLY AND GROUND CIRCUIT | 10 | OPERATE BUT REAR WINDOW DEFOG- | |
| Description | 10 | GER OPERATES | 37 |
| Component Function Check | 10 | Diagnosis Procedure | 37 |
| Diagnosis Procedure | 10 | DRIVER SIDE DOOR MIRROR DEFOGGER | |
| Component Inspection | 11 | DOES NOT OPERATE. | 38 |
| DOOR MIRROR DEFOGGER LH | 12 | Diagnosis Procedure | 38 |

| | | | |
|--|-----------|--|-----------|
| PASSENGER SIDE DOOR MIRROR DEFOGGER DOES NOT OPERATE. | 39 | PRECAUTIONS | 41 |
| Diagnosis Procedure | 39 | Precaution for Supplemental Restraint System (SRS) "AIR BAG" and "SEAT BELT PRE-TENSIONER" | 41 |
| REAR WINDOW DEFOGGER SWITCH DOES NOT LIGHT, BUT REAR WINDOW DEFOGGER OPERATES | 40 | Handling for Adhesive and Primer | 41 |
| Diagnosis Procedure | 40 | REMOVAL AND INSTALLATION | 42 |
| PRECAUTION | 41 | REAR WINDOW DEFOGGER | 42 |
| | | Filament Check | 42 |
| | | Filament Repair | 42 |

DIAGNOSIS AND REPAIR WORKFLOW

< BASIC INSPECTION >

BASIC INSPECTION

DIAGNOSIS AND REPAIR WORKFLOW

Repair Work Flow

INFOID:000000009484745

DETAILED FLOW

1. LISTEN TO CUSTOMER COMPLAINT

Listen to customer complaint. Get detailed information about the conditions and environment when the symptom occurs.

>> GO TO 2

2. VERIFY THE SYMPTOM WITH OPERATIONAL CHECK

Verify the symptom with operational check.

>> GO TO 3

3. GO TO APPROPRIATE TROUBLE DIAGNOSIS

Go to appropriate trouble diagnosis.

>> GO TO 4

4. REPAIR OR REPLACE

Repair or replace the specific parts.

>> GO TO 5

5. FINAL CHECK

Final check.

Is inspection result normal?

YES >> Inspection End

NO >> Check for intermittent incident. Refer to [GI-40, "Intermittent Incident"](#).

A

B

C

D

E

F

G

H

I

J

K

DEF

M

N

O

P

REAR WINDOW DEFOGGER SYSTEM

< SYSTEM DESCRIPTION >

SYSTEM DESCRIPTION

REAR WINDOW DEFOGGER SYSTEM

System Diagram

INFOID:000000009484747

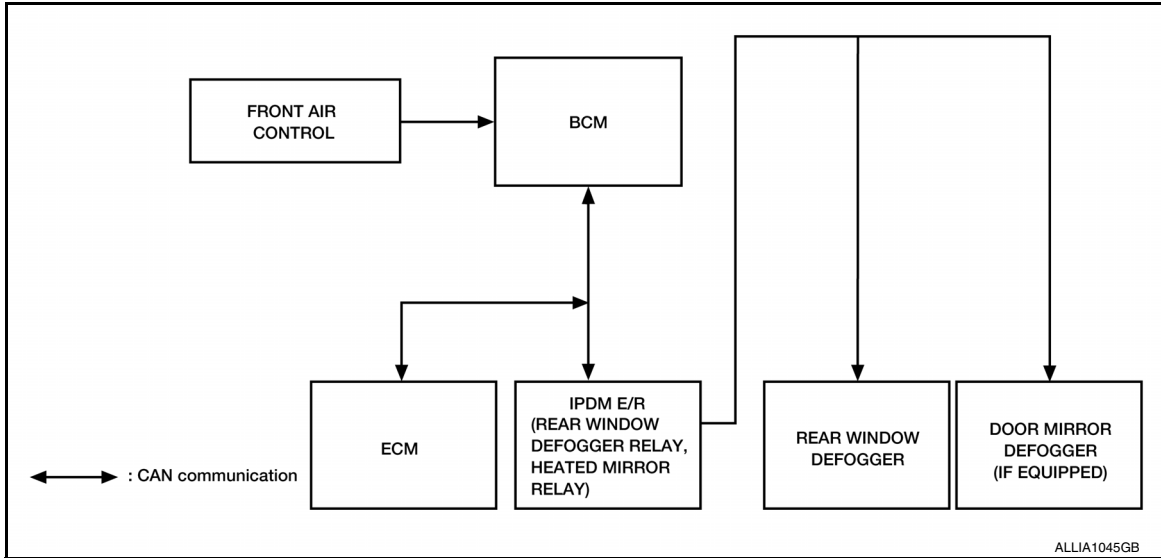

System Description

INFOID:000000009484748

Operation Description

- When rear window defogger switch is turned ON while ignition switch is ON, the front air control transmits rear window defogger switch signal to BCM.
- BCM transmits rear window defogger control signal to IPDM E/R via CAN communication when rear window defogger operates.
- IPDM E/R turns rear window defogger relay and heated mirror relay (if equipped) ON when rear window defogger switch signal is received.
- Rear window defogger and door mirror defogger (if equipped) are supplied with power and operate when rear window defogger relay and heated mirror relay (if equipped) turn ON.
- Rear window defogger ON is displayed when signal is received.

Timer Function

- BCM turns rear window defogger relay and heated mirror relay (if equipped) ON for approximately 15 minutes when rear window defogger switch is turned ON while ignition switch is ON. It makes rear window defogger and door mirror defogger (if equipped) operate.
- Timer is canceled after pressing rear window defogger switch again during timer operation. Then BCM turns rear window defogger relay and heated mirror relay (if equipped) OFF. The same reaction also occurs during timer operation, if the ignition switch is turned OFF.

INPUT/OUTPUT SIGNAL CHART

| Switch | Input signal to BCM | BCM function | Actuator |
|-----------------------------|------------------------|---|--|
| Rear window defogger switch | Defogger switch signal | Rear window defogger & door mirror defogger (if equipped) control | Rear window defogger Door mirror defogger (if equipped) |
| Ignition switch | Ignition signal | | |

REAR WINDOW DEFOGGER SYSTEM

< SYSTEM DESCRIPTION >

Component Parts Location

INFOID:000000009484749

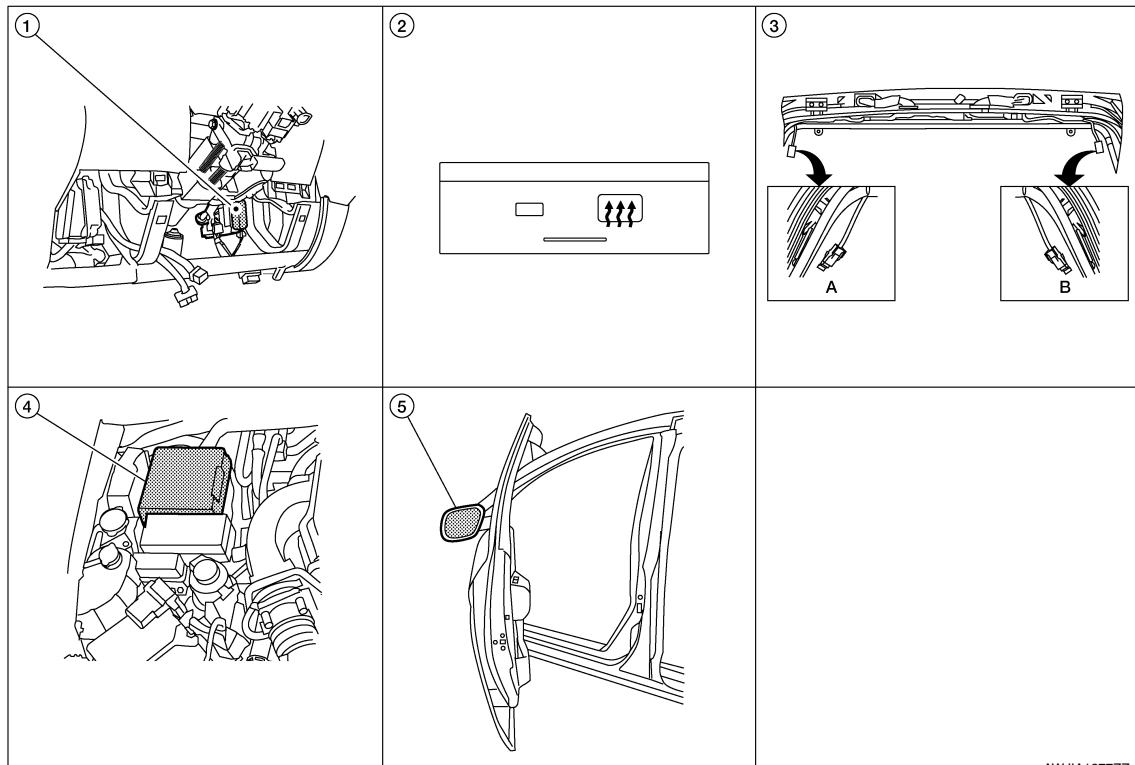

AWJIA1277ZZ

1. BCM M18, M19, M20 (view with lower instrument panel LH removed)
2. Rear window defogger switch
3. A. Rear window defogger ground connector D604
B. Rear window defogger connector D651
4. IPDM E/R (rear window defogger relay, heated mirror relay if equipped) E120, E122, E124
5. Door mirror (door mirror defogger) LH D4, RH D107 (if equipped)

Component Description

INFOID:000000009484750

| | |
|-----------------------------|---|
| BCM | <ul style="list-style-type: none"> Operates the rear window defogger with the operation of rear window defogger switch. Performs the timer control of rear window defogger. |
| Rear window defogger relay | <ul style="list-style-type: none"> Operates the rear window defogger with the control signal from BCM. |
| Rear window defogger switch | <ul style="list-style-type: none"> The rear window defogger switch is turned ON. Turns the indicator lamp ON when detecting the operation of rear window defogger. |
| Rear window defogger | <ul style="list-style-type: none"> Heats the heating wire with the power supply from the rear window defogger relay to prevent the rear window from fogging up. |
| Heated mirror relay* | Operates the door mirror defogger with the control signal from IPDM E/R. Controlled simultaneously with the rear window defogger relay. |
| Door mirror defogger* | The heating elements heat up when powered by the heated mirror relay to defog the door mirrors or prevent the door mirrors from fogging up. |

*:if equipped

A
B
C
D
E
F
G
H
I
J
K

DEF

M
N
O
P

DIAGNOSIS SYSTEM (BCM)

< SYSTEM DESCRIPTION >

DIAGNOSIS SYSTEM (BCM)

COMMON ITEM

COMMON ITEM : CONSULT Function (BCM - COMMON ITEM)

INFOID:000000010247926

APPLICATION ITEM

CONSULT performs the following functions via CAN communication with BCM.

| Direct Diagnostic Mode | Description |
|------------------------|--|
| ECU Identification | The BCM part number is displayed. |
| Self Diagnostic Result | The BCM self diagnostic results are displayed. |
| Data Monitor | The BCM input/output data is displayed in real time. |
| Active Test | The BCM activates outputs to test components. |
| Work support | The settings for BCM functions can be changed. |
| Configuration | <ul style="list-style-type: none"> The vehicle specification can be read and saved. The vehicle specification can be written when replacing BCM. |
| CAN Diag Support Mntr | The result of transmit/receive diagnosis of CAN communication is displayed. |

SYSTEM APPLICATION

BCM can perform the following functions.

| System | Sub System | Direct Diagnostic Mode | | | | | | |
|--------------------------------------|----------------------|------------------------|------------------------|--------------|-------------|--------------|---------------|-----------------------|
| | | ECU Identification | Self Diagnostic Result | Data Monitor | Active Test | Work support | Configuration | CAN Diag Support Mntr |
| Door lock | DOOR LOCK | | | x | x | x | | |
| Rear window defogger | REAR DEFOGGER | | | x | x | | | |
| Warning chime | BUZZER | | | x | x | | | |
| Interior room lamp timer | INT LAMP | | | x | x | x | | |
| Remote keyless entry system | MULTI REMOTE ENT | | | x | x | x | | |
| Exterior lamp | HEAD LAMP | | | x | x | x | | |
| Wiper and washer | WIPER | | | x | x | x | | |
| Turn signal and hazard warning lamps | FLASHER | | | x | x | | | |
| Air conditioner | AIR CONDITIONER | | | x | | | | |
| Combination switch | COMB SW | | | x | | | | |
| BCM | BCM | x | x | | | x | x | x |
| Immobilizer | IMMU | | x | x | x | | | |
| Interior room lamp battery saver | BATTERY SAVER | | | x | x | x | | |
| Back door open | TRUNK | | | x | x | | | |
| Vehicle security system | THEFT ALM | | | x | x | x | | |
| RAP system | RETAINED PWR | | | x | x | x | | |
| Signal buffer system | SIGNAL BUFFER | | | x | x | | | |
| TPMS | AIR PRESSURE MONITOR | | x | x | x | x | | |
| Panic alarm system | PANIC ALARM | | | | x | | | |

REAR DEFOGGER

DIAGNOSIS SYSTEM (BCM)

< SYSTEM DESCRIPTION >

REAR DEFOGGER : CONSULT Function (BCM - REAR DEFOGGER)

INFOID:000000010247927

DATA MONITOR

| Monitor Item [Unit] | Description |
|----------------------|--|
| IGN ON SW [On/Off] | Indicates condition of ignition switch ON position. |
| ACC ON SW [On/Off] | Indicates condition of ignition switch ACC position. |
| REAR DEF SW [On/Off] | Indicates condition of rear window defogger switch. |

ACTIVE TEST

| Test Item | Description |
|---------------|---|
| REAR DEFOGGER | This test is able to check rear window defogger operation [Off/On]. |

A
B
C
D
E
F
G
H
I
J
K
DEF
M
N
O
P

REAR WINDOW DEFOGGER SWITCH

< DTC/CIRCUIT DIAGNOSIS >

DTC/CIRCUIT DIAGNOSIS

REAR WINDOW DEFOGGER SWITCH

Description

INFOID:000000009484754

- The rear window defogger is operated by turning the rear window defogger switch ON.
- Turns the indicator lamp in the rear window defogger switch ON when operating the rear window defogger.

Component Function Check

INFOID:000000009484755

1. CHECK REAR WINDOW DEFOGGER SWITCH FUNCTION

Check that the indicator lamp of rear window defogger illuminates with rear window defogger switch ON.

Is the inspection result normal?

- YES >> Rear window defogger switch function is OK.
NO >> Refer to [DEF-8, "Diagnosis Procedure"](#).

Diagnosis Procedure

INFOID:000000009484756

Regarding Wiring diagram information, refer to [DEF-27, "Wiring Diagram"](#).

1. CHECK FRONT AIR CONTROL (REAR WINDOW DEFOGGER SWITCH) CIRCUIT

Operate the rear window defogger switch.

Is the inspection result normal?

- YES >> Inspection End.
NO >> GO TO 2

2. CHECK HARNESS CONTINUITY

1. Turn ignition switch OFF.
2. Disconnect BCM and front air control.
3. Check continuity between BCM harness connector M19 terminal 41 and front air control harness connector M50 terminal 16.

| BCM connector | Terminal | Front air control connector | Terminal | Continuity |
|---------------|----------|-----------------------------|----------|------------|
| M19 | 41 | M50 | 16 | Yes |

4. Check continuity between BCM harness connector M19 terminal 41 and ground.

| BCM connector | Terminal | Ground | Continuity |
|---------------|----------|--------|------------|
| M19 | 41 | Ground | No |

Is the inspection result normal?

- YES >> Replace front air control. Refer to [VTL-7, "Removal and Installation"](#).
NO >> Repair or replace harness.

REAR WINDOW DEFOGGER RELAY

< DTC/CIRCUIT DIAGNOSIS >

REAR WINDOW DEFOGGER RELAY

Description

INFOID:000000009484758

Power is supplied to the rear window defogger with BCM control.

Component Function Check

INFOID:000000009484759

1. CHECK REAR WINDOW DEFOGGER RELAY POWER SUPPLY CIRCUIT

Check that an operation noise of rear window defogger relay (located in IPDM E/R) can be heard when turning the rear window defogger switch ON.

Is the inspection result normal?

- YES >> Rear window defogger relay power supply circuit is OK.
- NO >> Refer to [DEF-9, "Diagnosis Procedure"](#).

Diagnosis Procedure

INFOID:000000009484760

Regarding Wiring diagram information, refer to [DEF-27, "Wiring Diagram"](#).

1. CHECK FUSES

Check if any of the following fuses in the IPDM E/R are blown.

| COMPONENT PARTS | AMPERE | FUSE NO. |
|-----------------|--------|----------|
| IPDM E/R | 15A | 46 |
| IPDM E/R | 15A | 47 |

Is the inspection result normal?

- YES >> GO TO 2
- NO >> If fuse is blown, be sure to eliminate cause of malfunction before installing new fuse.

2. CHECK REAR WINDOW DEFOGGER RELAY POWER SUPPLY CIRCUIT

1. Turn ignition switch ON.
2. Check voltage between IPDM E/R harness connector E124 terminal 60 and ground.

| Terminals | | Condition of rear window defogger switch | Voltage (V) (Approx.) |
|--------------------|----------|--|-----------------------|
| (+) | (-) | | |
| IPDM E/R connector | Terminal | | |
| E124 | 60 | ON | Battery voltage |
| | | OFF | 0 |

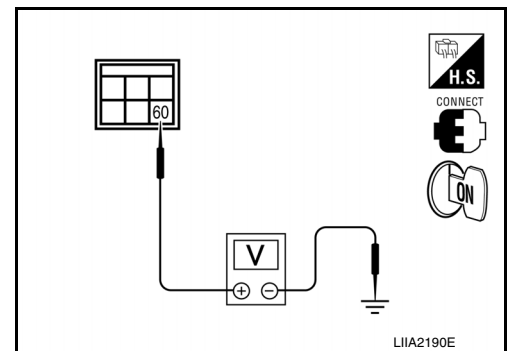

Is the inspection result normal?

- YES >> GO TO 3.
- NO >> Replace IPDM E/R. Refer to [PCS-27, "Removal and Installation"](#).

3. CHECK INTERMITTENT INCIDENT

Check for intermittent incident.
Refer to [GI-40, "Intermittent Incident"](#).

Is the inspection result normal?

- YES >> Check the following.
 - Battery power supply circuit
 - IPDM E/R
- NO >> Repair or replace the malfunctioning parts.

A
B
C
D
E
F
G
H
I
J
K
DEF
M
N
O
P

REAR WINDOW DEFOGGER POWER SUPPLY AND GROUND CIRCUIT

< DTC/CIRCUIT DIAGNOSIS >

REAR WINDOW DEFOGGER POWER SUPPLY AND GROUND CIRCUIT

Description

INFOID:000000009484761

Heats the heating wire with the power supply from the rear window defogger relay to prevent the rear window from fogging up.

Component Function Check

INFOID:000000009484762

1. CHECK REAR WINDOW DEFOGGER

Check that the heating wire of rear window defogger is heated when turning the rear window defogger switch ON.

Is the inspection result normal?

- YES >> Rear window defogger is OK.
- NO >> Refer to [DEF-10, "Diagnosis Procedure"](#).

Diagnosis Procedure

INFOID:000000009484763

Regarding Wiring diagram information, refer to [DEF-27, "Wiring Diagram"](#).

1. CHECK POWER SUPPLY CIRCUIT

1. Turn ignition switch ON.
2. Check voltage between rear window defogger harness connector D651 terminal 1 and ground.

| Terminals | | Condition of rear window defogger switch | Voltage (V) (Approx.) |
|--------------------------------|----------|--|-----------------------|
| (+) | (-) | | |
| Rear window defogger connector | Terminal | | |
| D651 | 1 | ON | Battery voltage |
| | | OFF | 0 |

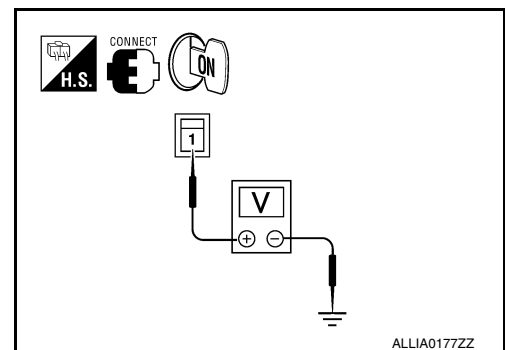

Is the inspection result normal?

- YES >> GO TO 2
- NO >> GO TO 3

2. CHECK GROUND CIRCUIT

1. Turn ignition switch OFF.
2. Disconnect rear window defogger.
3. Check continuity between rear window defogger harness connector D604 terminal 2 and ground.

| Rear window defogger connector | Terminal | Ground | Continuity |
|--------------------------------|----------|--------|------------|
| D604 | 2 | | Yes |

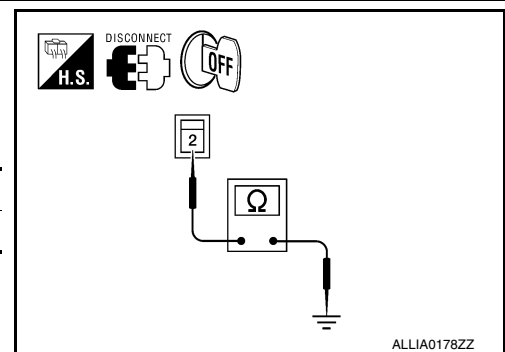

Is the inspection result normal?

- YES >> GO TO 4
- NO >> Repair or replace harness.

3. CHECK HARNESS CONTINUITY

REAR WINDOW DEFOGGER POWER SUPPLY AND GROUND CIRCUIT

< DTC/CIRCUIT DIAGNOSIS >

1. Disconnect IPDM E/R.
2. Check continuity between rear window defogger harness connector D651 (A) terminal 1 and IPDM E/R harness E124 (B) terminal 60 connector.

| Rear window defogger connector | Terminal | IPDM E/R connector | Terminal | Continuity |
|--------------------------------|----------|--------------------|----------|------------|
| D651 (A) | 1 | E124 (B) | 60 | Yes |

3. Check continuity between rear window defogger harness connector D651 (A) terminal 1 and ground.

| Rear window defogger connector | Terminal | Ground | Continuity |
|--------------------------------|----------|--------|------------|
| D651 (A) | 1 | | No |

Is the inspection result normal?

- YES >> GO TO 5
 NO >> Replace or repair harness as necessary.

4. CHECK FILAMENT

Check filament.

Refer to [DEF-11, "Component Inspection"](#).

Is the inspection result normal?

- YES >> Check for intermittent incident. Refer to [GI-40, "Intermittent Incident"](#).
 NO >> Repair filament. Refer to [DEF-42, "Filament Repair"](#).

5. CHECK INTERMITTENT INCIDENT

Check intermittent incident.

Refer to [GI-40, "Intermittent Incident"](#).

Is the inspection result normal?

- YES >> Check the following.
- Battery power supply circuit
 - IPDM E/R
- NO >> Repair or replace the malfunctioning parts.

Component Inspection

INFOID:000000009484764

1. CHECK FILAMENT

Check the filament for damage or open circuits.

Refer to [DEF-42, "Filament Check"](#).

Is the inspection result normal?

- YES >> Inspection End.
 NO >> Repair filament. Refer to [DEF-42, "Filament Repair"](#).

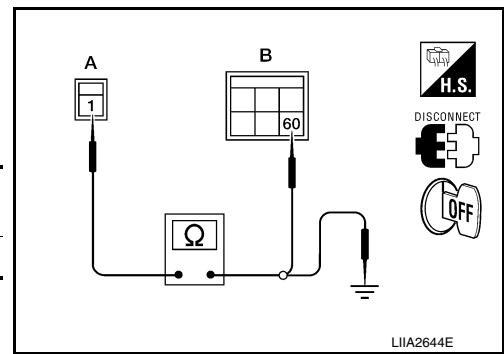

A
B
C
D
E
F
G
H
I
J
K
DEF
M
N
O
P

DOOR MIRROR DEFOGGER LH

< DTC/CIRCUIT DIAGNOSIS >

DOOR MIRROR DEFOGGER LH

Description

INFOID:000000009484765

Heats the heating wire with the power supply from the heated mirror relay to prevent the door mirror from fogging up.

Component Function Check

INFOID:000000009484766

1. CHECK DOOR MIRROR DEFOGGER LH

Check that heating wire of door mirror defogger LH is heated when turning the rear window defogger switch ON.

Is the inspection result normal?

- YES >> Door mirror defogger LH is OK.
- NO >> Refer to [DEF-12, "Diagnosis Procedure"](#).

Diagnosis Procedure

INFOID:000000009484767

Regarding Wiring diagram information, refer to [DEF-27, "Wiring Diagram"](#).

1. CHECK POWER SUPPLY

Check if the following fuse in the IPDM E/R is blown.

| COMPONENT PARTS | AMPERE | FUSE NO. |
|-----------------|--------|----------|
| IPDM E/R | 15A | 43 |

Is the inspection result normal?

- YES >> GO TO 2
- NO >> If fuse is blown, be sure to eliminate cause of malfunction before installing new fuse.

2. CHECK DOOR MIRROR DEFOGGER POWER SUPPLY CIRCUIT

1. Turn ignition switch ON.
2. Check voltage between IPDM E/R harness connector E120 terminal 23 and ground.

| Connector | Terminal | | Condition | Voltage (V) (Approx.) |
|-----------|----------|--------|---------------------------------|--------------------------|
| | (+) | (-) | | |
| E120 | 23 | Ground | Rear window defogger switch ON | Battery voltage |
| | | | Rear window defogger switch OFF | 0 |

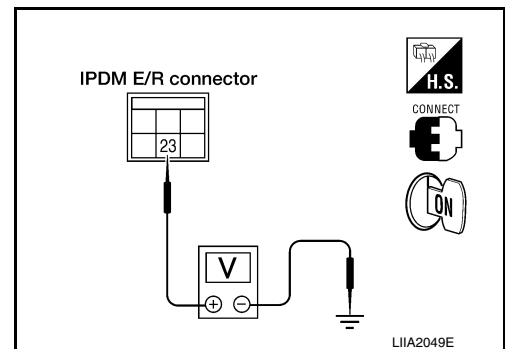

Is the inspection result normal?

- YES >> GO TO 3
- NO >> Replace IPDM E/R. Refer to [PCS-27, "Removal and Installation"](#).

3. CHECK DOOR MIRROR DEFOGGER LH POWER SUPPLY CIRCUIT

DOOR MIRROR DEFOGGER LH

< DTC/CIRCUIT DIAGNOSIS >

1. Turn ignition switch OFF.
2. Disconnect door mirror LH.
3. Turn ignition switch ON.
4. Check voltage between door mirror LH harness connector D4 terminal 1 and ground.

| Connector | Terminal | | Condition | Voltage (V) (Approx.) |
|-----------|----------|--------|---------------------------------|--------------------------|
| | (+) | (-) | | |
| D4 | 1 | Ground | Rear window defogger switch ON | Battery voltage |
| | | | Rear window defogger switch OFF | 0 |

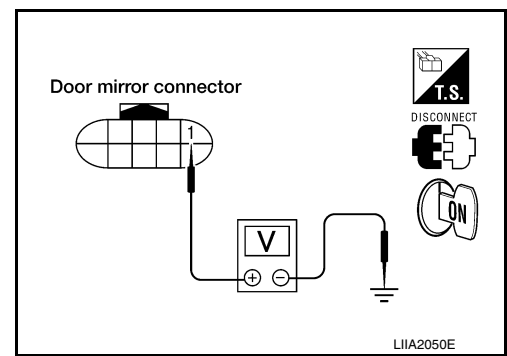

Is the inspection result normal?

- YES >> GO TO 4
NO >> Repair or replace harness.

4. CHECK DOOR MIRROR DEFOGGER LH CIRCUIT

1. Turn ignition switch OFF.
2. Disconnect IPDM E/R.
3. Check continuity between IPDM E/R harness connector E120 (A) terminal 23 and door mirror LH harness connector D4 (B) terminal 1.

| Connector | Terminal | Connector | Terminal | Continuity |
|----------------|----------|-----------------|----------|------------|
| A | | B | | |
| IPDM E/R: E120 | 23 | Door mirror: D4 | 1 | Yes |

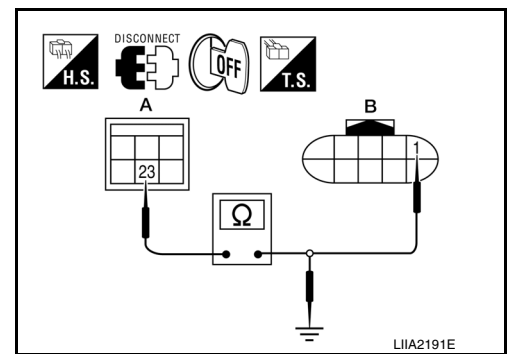

4. Check continuity between IPDM E/R harness connector E120 (A) terminal 23 and ground.

| A | | Ground | Continuity |
|----------------|----------|--------|------------|
| Connector | Terminal | | |
| IPDM E/R: E120 | 23 | | No |

Is the inspection result normal?

- YES >> GO TO 5.
NO >> Repair or replace harness.

5. CHECK DOOR MIRROR DEFOGGER LH GROUND CIRCUIT

Check continuity between door mirror LH harness connector D4 terminal 6 and ground.

6 - Ground : Continuity should exist.

Is the inspection result normal?

- YES >> GO TO 6
NO >> Repair or replace harness.

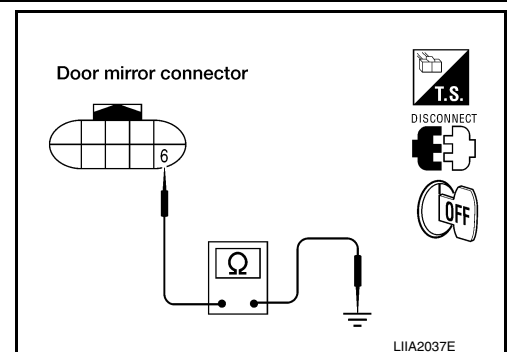

6. CHECK DOOR MIRROR DEFOGGER LH

Check door mirror defogger LH.
Refer to [DEF-14, "Component Inspection"](#).

Is the inspection result normal?

- YES >> GO TO 7

A
B
C
D
E
F
G
H
I
J
K
M
N
O
P

DEF

DOOR MIRROR DEFOGGER LH

< DTC/CIRCUIT DIAGNOSIS >

NO >> Replace door mirror LH. Refer to [MIR-20, "Door Mirror Assembly"](#).

7. CHECK INTERMITTENT INCIDENT

Check intermittent incident.

Refer to [GI-40, "Intermittent Incident"](#).

Is the inspection result normal?

- YES >> Check the following.
- Battery power supply circuit
 - IPDM E/R

NO >> Repair or replace the malfunctioning parts.

Component Inspection

INFOID:000000009484768

1. CHECK DOOR MIRROR DEFOGGER LH

Check continuity between door mirror LH terminals 1 and 6.

1 - 6 : Continuity should exist.

Is the inspection result normal?

- YES >> Check the condition of the harness and the connector.
- NO >> Replace malfunctioning door mirror LH. Refer to [MIR-20, "Door Mirror Assembly"](#).

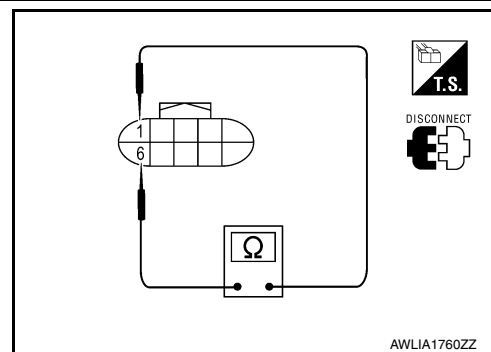

DOOR MIRROR DEFOGGER RH

< DTC/CIRCUIT DIAGNOSIS >

DOOR MIRROR DEFOGGER RH

Description

INFOID:000000009484769

Heats the heating wire with the power supply from the heated mirror relay to prevent the door mirror from fogging up.

Component Function Check

INFOID:000000009484770

1. CHECK DOOR MIRROR DEFOGGER RH

Check that the heating wire of door mirror defogger RH is heated when turning the rear window defogger switch ON.

Is the inspection result normal?

- YES >> Door mirror defogger RH is OK.
- NO >> Refer to [DEF-15, "Diagnosis Procedure"](#).

Diagnosis Procedure

INFOID:000000009484771

Regarding Wiring diagram information, refer to [DEF-27, "Wiring Diagram"](#).

1. CHECK POWER SUPPLY

Check if the following fuse in the IPDM E/R is blown.

| COMPONENT PARTS | AMPERE | FUSE NO. |
|-----------------|--------|----------|
| IPDM E/R | 15A | 43 |

Is the inspection result normal?

- YES >> GO TO 2
- NO >> If fuse is blown, be sure to eliminate cause of malfunction before installing new fuse.

2. CHECK DOOR MIRROR DEFOGGER POWER SUPPLY CIRCUIT

1. Turn ignition switch ON.
2. Check voltage between IPDM E/R harness connector E120 terminal 23 and ground.

| Connector | Terminal | | Condition | Voltage (V) (Approx.) |
|-----------|----------|--------|---------------------------------|--------------------------|
| | (+) | (-) | | |
| E120 | 23 | Ground | Rear window defogger switch ON | Battery voltage |
| | | | Rear window defogger switch OFF | 0 |

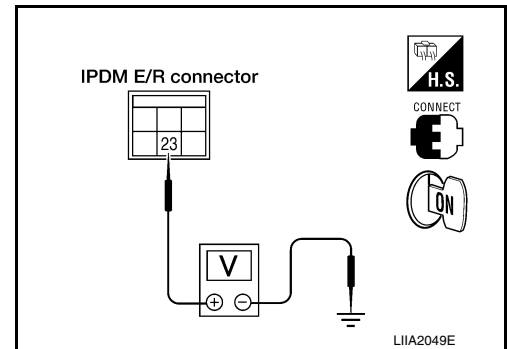

Is the inspection result normal?

- YES >> GO TO 3
- NO >> Replace IPDM E/R. Refer to [PCS-27, "Removal and Installation"](#).

3. CHECK DOOR MIRROR DEFOGGER RH POWER SUPPLY CIRCUIT

A
B
C
D
E
F
G
H
I
J
K
DEF
M
N
O
P

DOOR MIRROR DEFOGGER RH

< DTC/CIRCUIT DIAGNOSIS >

1. Turn ignition switch OFF.
2. Disconnect door mirror RH.
3. Turn ignition switch ON.
4. Check voltage between door mirror RH harness connector D107 terminal 1 and ground.

| Connector | Terminal | | Condition | Voltage (V) (Approx.) |
|-----------|----------|--------|---------------------------------|--------------------------|
| | (+) | (-) | | |
| D107 | 1 | Ground | Rear window defogger switch ON | Battery voltage |
| | | | Rear window defogger switch OFF | 0 |

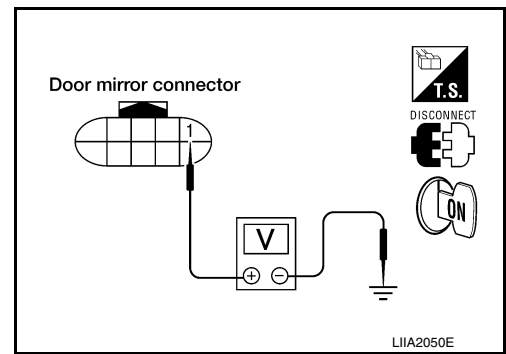

Is the inspection result normal?

- YES >> GO TO 4
 NO >> Repair or replace harness.

4. CHECK DOOR MIRROR DEFOGGER RH CIRCUIT

1. Turn ignition switch OFF.
2. Disconnect IPDM E/R.
3. Check continuity between IPDM E/R harness connector E120 (A) terminal 23 and door mirror RH harness connector D107 (B) terminal 1.

| Connector | Terminal | Connector | Terminal | Continuity |
|----------------|----------|-------------------|----------|------------|
| A | | B | | |
| IPDM E/R: E120 | 23 | Door mirror: D107 | 1 | Yes |

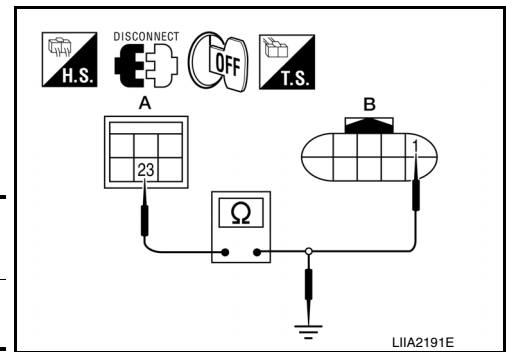

4. Check continuity between IPDM E/R harness connector D120 (A) terminal 23 and ground.

| A | | Ground | Continuity |
|----------------|----------|--------|------------|
| Connector | Terminal | | |
| IPDM E/R: E120 | 23 | | No |

Is the inspection result normal?

- YES >> GO TO 5.
 NO >> Repair or replace harness.

5. CHECK DOOR MIRROR DEFOGGER RH GROUND CIRCUIT

Check continuity between door mirror RH harness connector D107 terminal 6 and ground.

6 - Ground : Continuity should exist.

Is the inspection result normal?

- YES >> GO TO 6
 NO >> Repair or replace harness.

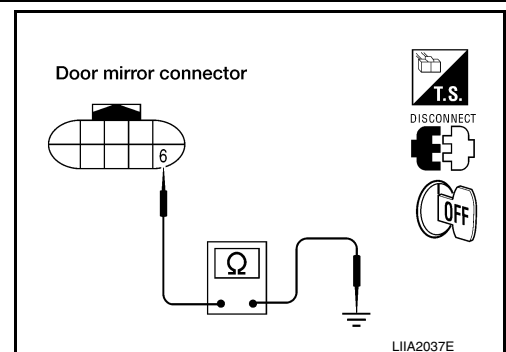

6. CHECK DOOR MIRROR DEFOGGER RH

Check door mirror defogger RH.
 Refer to [DEF-17, "Component Inspection"](#).

Is the inspection result normal?

- YES >> GO TO 7

DOOR MIRROR DEFOGGER RH

< DTC/CIRCUIT DIAGNOSIS >

NO >> Replace door mirror RH. Refer to [MIR-20. "Door Mirror Assembly"](#).

7. CHECK INTERMITTENT INCIDENT

Check intermittent incident.

Refer to [GI-40. "Intermittent Incident"](#).

Is the inspection result normal?

YES >> Check the following.

- Battery power supply circuit
- IPDM E/R

NO >> Repair or replace the malfunctioning parts.

Component Inspection

INFOID:000000009484772

1. CHECK DOOR MIRROR DEFOGGER RH

Check continuity between door mirror RH terminals 1 and 6.

1 - 6

: Continuity should exist.

Is the inspection result normal?

YES >> Check the condition of the harness and the connector.

NO >> Replace malfunctioning door mirror RH. Refer to [MIR-20. "Door Mirror Assembly"](#).

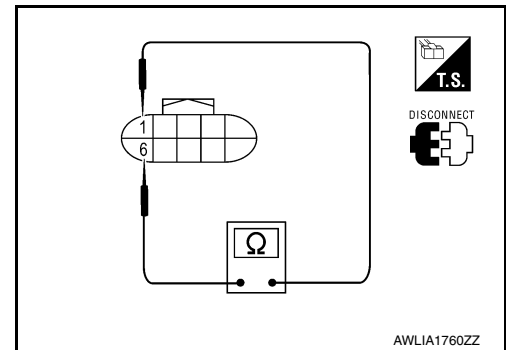

A
B
C
D
E
F
G
H
I
J
K
DEF
M
N
O
P

BCM (BODY CONTROL MODULE)

< ECU DIAGNOSIS INFORMATION >

ECU DIAGNOSIS INFORMATION

BCM (BODY CONTROL MODULE)

Reference Value

INFOID:0000000010247928

NOTE:

The Signal Tech II Tool (J-50190) can be used to perform the following functions. Refer to the Signal Tech II User Guide for additional information.

- Activate and display TPMS transmitter IDs
- Display tire pressure reported by the TPMS transmitter
- Read TPMS DTCs
- Register TPMS transmitter IDs

VALUES ON THE DIAGNOSIS TOOL

| Monitor Item | Condition | Value/Status |
|---------------|--|-------------------------------|
| ACC ON SW | Ignition switch OFF or ON | Off |
| | Ignition switch ACC | On |
| AIR COND SW | A/C switch OFF | Off |
| | A/C switch ON | On |
| AIR PRESS FL | Front left tire air pressure value | kPa, kg/cm ² , psi |
| AIR PRESS FR | Front right tire air pressure value | kPa, kg/cm ² , psi |
| AIR PRESS RL | Rear left tire air pressure value | kPa, kg/cm ² , psi |
| AIR PRESS RR | Rear right tire air pressure value | kPa, kg/cm ² , psi |
| AUTO LIGHT SW | Lighting switch OFF | Off |
| | Lighting switch AUTO | On |
| BACK DOOR SW | Back door closed | Off |
| | Back door opened | On |
| BRAKE SW | Brake pedal released | Off |
| | Brake pedal applied | On |
| BUCKLE SW | Seat belt buckle unfastened | Off |
| | Seat belt buckle fastened | On |
| BUZZER | Buzzer in combination meter OFF | Off |
| | Buzzer in combination meter ON | On |
| CARGO LAMP SW | Cargo lamp switch OFF | Off |
| | Cargo lamp switch ON | On |
| CDL LOCK SW | Door lock/unlock switch does not operate | Off |
| | Press door lock/unlock switch to the LOCK side | On |
| CDL UNLOCK SW | Door lock/unlock switch does not operate | Off |
| | Press door lock/unlock switch to the UNLOCK side | On |
| DOOR SW-AS | Front door RH closed | Off |
| | Front door RH opened | On |
| DOOR SW-DR | Front door LH closed | Off |
| | Front door LH opened | On |
| DOOR SW-RL | Rear door LH closed | Off |
| | Rear door LH opened | On |
| DOOR SW-RR | Rear door RH closed | Off |
| | Rear door RH opened | On |

BCM (BODY CONTROL MODULE)

< ECU DIAGNOSIS INFORMATION >

| Monitor Item | Condition | Value/Status | |
|----------------|---|--------------|-----|
| ENGINE RUN | Engine stopped | Off | A |
| | Engine running | On | |
| FAN ON SIG | Blower motor fan switch OFF | Off | B |
| | Blower motor fan switch ON | On | |
| FR FOG SW | Front fog lamp switch OFF | Off | C |
| | Front fog lamp switch ON | On | |
| FR WASHER SW | Front washer switch OFF | Off | |
| | Front washer switch ON | On | D |
| FR WIPER LOW | Front wiper switch OFF | Off | |
| | Front wiper switch LO | On | |
| FR WIPER HI | Front wiper switch OFF | Off | E |
| | Front wiper switch HI | On | |
| FR WIPER INT | Front wiper switch OFF | Off | F |
| | Front wiper switch INT | On | |
| FR WIPER STOP | Any position other than front wiper stop position | Off | |
| | Front wiper stop position | On | G |
| HAZARD SW | When hazard switch is not pressed | Off | |
| | When hazard switch is pressed | On | H |
| HEAD LAMP SW 1 | Headlamp switch OFF | Off | |
| | Headlamp switch 1st | On | |
| HEAD LAMP SW 2 | Headlamp switch OFF | Off | I |
| | Headlamp switch 1st | On | |
| HI BEAM SW | High beam switch OFF | Off | |
| | High beam switch HI | On | J |
| ID REGST FL1 | ID registration of front left tire incomplete | YET | |
| | ID registration of front left tire complete | DONE | K |
| ID REGST FR1 | ID registration of front right tire incomplete | YET | |
| | ID registration of front right tire complete | DONE | |
| ID REGST RL1 | ID registration of rear left tire incomplete | YET | DEF |
| | ID registration of rear left tire complete | DONE | |
| ID REGST RR1 | ID registration of rear right tire incomplete | YET | |
| | ID registration of rear right tire complete | DONE | M |
| IGN ON SW | Ignition switch OFF or ACC | Off | |
| | Ignition switch ON | On | N |
| IGN SW CAN | Ignition switch OFF or ACC | Off | |
| | Ignition switch ON | On | |
| INT VOLUME | Wiper intermittent dial is in a dial position 1 - 7 | 1 - 7 | O |
| KEY CYL LK-SW | Door key cylinder LOCK position | Off | |
| | Door key cylinder other than LOCK position | On | P |
| KEY CYL UN-SW | Door key cylinder UNLOCK position | Off | |
| | Door key cylinder other than UNLOCK position | On | |
| KEY ON SW | Mechanical key is removed from key cylinder | Off | |
| | Mechanical key is inserted to key cylinder | On | |

BCM (BODY CONTROL MODULE)

< ECU DIAGNOSIS INFORMATION >

| Monitor Item | Condition | Value/Status |
|----------------|--|-----------------------------------|
| KEYLESS LOCK | LOCK button of key fob is not pressed | Off |
| | LOCK button of key fob is pressed | On |
| KEYLESS PANIC | PANIC button of key fob is not pressed | Off |
| | PANIC button of key fob is pressed | On |
| KEYLESS UNLOCK | UNLOCK button of key fob is not pressed | Off |
| | UNLOCK button of key fob is pressed | On |
| LIGHT SW 1ST | Lighting switch OFF | Off |
| | Lighting switch 1st | On |
| OIL PRESS SW | <ul style="list-style-type: none"> • Ignition switch OFF or ACC • Engine running | Off |
| | Ignition switch ON | On |
| OPTICAL SENSOR | Bright outside of the vehicle | Close to 5V |
| | Dark outside of the vehicle | Close to 0V |
| PASSING SW | Other than lighting switch PASS | Off |
| | Lighting switch PASS | On |
| PKB SW | Parking brake released | Off |
| | Parking brake engaged | On |
| REAR DEF SW | Rear window defogger switch OFF | Off |
| | Rear window defogger switch ON | On |
| RR WASHER SW | Rear washer switch OFF | Off |
| | Rear washer switch ON | On |
| RR WIPER INT | Rear wiper switch OFF | Off |
| | Rear wiper switch INT | On |
| RR WIPER ON | Rear wiper switch OFF | Off |
| | Rear wiper switch ON | On |
| RR WIPER STOP | Rear wiper stop position | Off |
| | Other than rear wiper stop position | On |
| TURN SIGNAL L | Turn signal switch OFF | Off |
| | Turn signal switch LH | On |
| TURN SIGNAL R | Turn signal switch OFF | Off |
| | Turn signal switch RH | On |
| VEHICLE SPEED | While driving | Equivalent to speedometer reading |
| WARNING LAMP | Low tire pressure warning lamp in combination meter OFF | Off |
| | Low tire pressure warning lamp in combination meter ON | On |

BCM (BODY CONTROL MODULE)

< ECU DIAGNOSIS INFORMATION >

Terminal Layout

INFOID:000000010247929

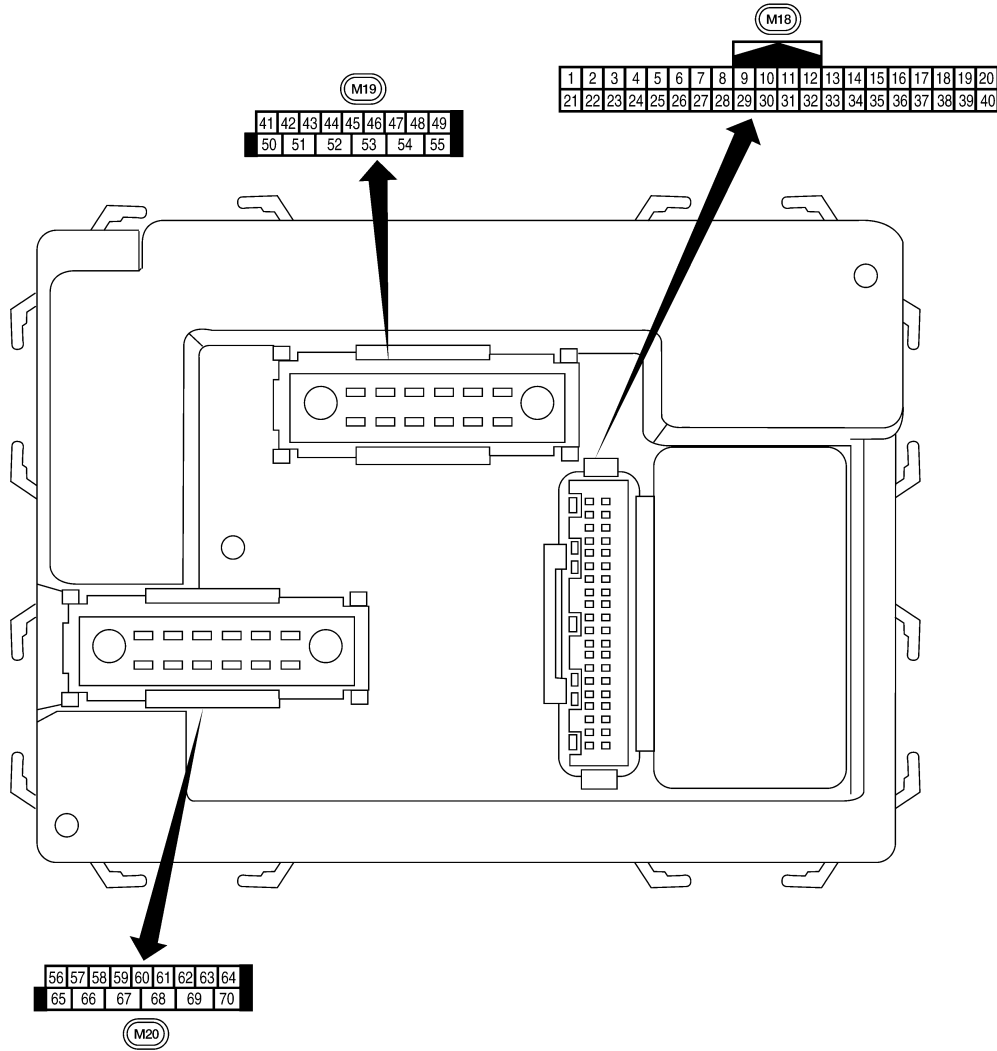

A
B
C
D
E
F
G
H
I
J
K
DEF
M
N
O
P



Physical Values

LIA2443E

INFOID:000000010247930

BCM (BODY CONTROL MODULE)

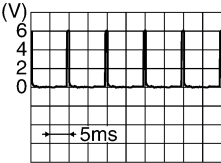
< ECU DIAGNOSIS INFORMATION >

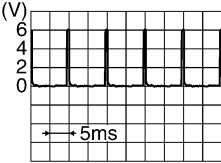
| Terminal | Wire color | Signal name | Signal input/output | Measuring condition | | Reference value or waveform (Approx.) |
|----------|------------|--|---------------------|---------------------|--|---|
| | | | | Ignition switch | Operation or condition | |
| 1 | BR | Ignition keyhole illumination | Output | OFF | Door is locked (SW OFF) | Battery voltage |
| | | | | | Door is unlocked (SW ON) | 0V |
| 2 | P | Combination switch input 5 | Input | ON | Lighting, turn, wiper OFF Wiper dial position 4 |  <p style="text-align: right; font-size: small;">SKIA5291E</p> |
| 3 | SB | Combination switch input 4 | Input | ON | Lighting, turn, wiper OFF Wiper dial position 4 |  <p style="text-align: right; font-size: small;">SKIA5292E</p> |
| 4 | V | Combination switch input 3 | Input | ON | Lighting, turn, wiper OFF Wiper dial position 4 |  <p style="text-align: right; font-size: small;">SKIA5291E</p> |
| 5 | L | Combination switch input 2 | Input | ON | Lighting, turn, wiper OFF Wiper dial position 4 |  <p style="text-align: right; font-size: small;">SKIA5292E</p> |
| 6 | R | Combination switch input 1 | | | | |
| 7 | GR | Front door lock assembly LH (key cylinder switch) and back door key cylinder switch (unlock) | Input | OFF | ON (open, 2nd turn) | Momentary 1.5V |
| | | | | | OFF (closed) | 0V |
| 8 | SB | Front door lock assembly LH (key cylinder switch) and back door key cylinder switch (lock) | Input | OFF | ON (open) | Momentary 1.5V |
| | | | | | OFF (closed) | 0V |
| 9 | LG | Stop lamp switch | Input | OFF | Brake pedal depressed | Battery voltage |
| | | | | | Brake pedal released | 0V |
| 11 | G/B | Ignition switch (ACC or ON) | Input | ACC or ON | Ignition switch ACC or ON | Battery voltage |
| 12 | LG | Front door switch RH | Input | OFF | ON (open) | 0V |
| | | | | | OFF (closed) | Battery voltage |
| 13 | L | Rear door switch RH | Input | OFF | ON (open) | 0V |
| | | | | | OFF (closed) | Battery voltage |

BCM (BODY CONTROL MODULE)

< ECU DIAGNOSIS INFORMATION >

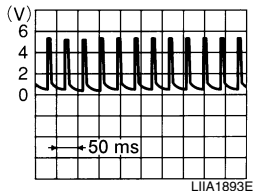
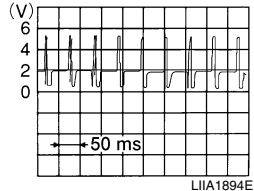
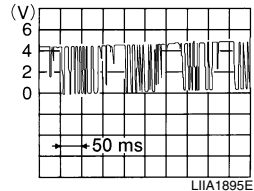
| Terminal | Wire color | Signal name | Signal input/output | Measuring condition | | Reference value or waveform (Approx.) |
|----------|------------|---|---------------------|---------------------|---|--|
| | | | | Ignition switch | Operation or condition | |
| 15 | W | Tire pressure warning check connector | Input | OFF | — | 5V |
| 18 | BR | Remote keyless entry receiver and optical sensor (ground) | Output | OFF | — | 0V |
| 19 | V | Remote keyless entry receiver (power supply) | Output | OFF | Ignition switch OFF |  |
| 20 | G | Remote keyless entry receiver (signal) | Input | OFF | Stand-by (keyfob buttons released) |  |
| | | | | | When remote keyless entry receiver receives signal from keyfob (keyfob buttons pressed) |  |
| 21 | GR | NATS antenna amp. | Input | OFF → ON | Ignition switch (OFF → ON) | Just after turning ignition switch ON: Pointer of tester should move for approx. 1 second, then return to battery voltage. |
| 23 | G | Security indicator lamp | Output | OFF | Goes OFF → illuminates (Every 2.4 seconds) | Battery voltage → 0V |
| 25 | BR | NATS antenna amp. | Input | OFF → ON | Ignition switch (OFF → ON) | Just after turning ignition switch ON: Pointer of tester should move for approx. 1 second, then return to battery voltage. |
| 27 | W | Compressor ON signal | Input | ON | A/C switch OFF | 5V |
| | | | | | A/C switch ON | 0V |
| 28 | R | Front blower monitor | Input | ON | Front blower motor OFF | Battery voltage |
| | | | | | Front blower motor ON | 0V |
| 29 | G | Hazard switch | Input | OFF | ON | 0V |
| | | | | | OFF | 5V |
| 31 | R | Off-road lamps switch | Input | ON | ON | 0V |
| | | | | | OFF | 5V |

A
B
C
D
E
F
G
H
I
J
K
DEF
M
N
O
P

BCM (BODY CONTROL MODULE)

< ECU DIAGNOSIS INFORMATION >

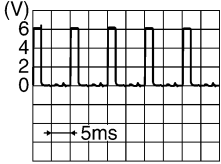
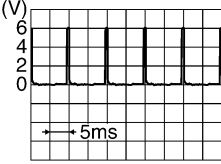
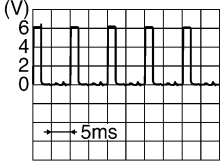
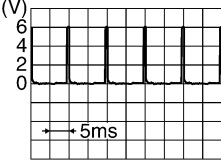
| Terminal | Wire color | Signal name | Signal input/output | Measuring condition | | Reference value or waveform (Approx.) |
|----------|------------|----------------------------------|---------------------|---------------------|--|---|
| | | | | Ignition switch | Operation or condition | |
| 32 | BG | Combination switch output 5 | Output | ON | Lighting, turn, wiper OFF Wiper dial position 4 |  <p style="text-align: right; font-size: small;">SKIA5291E</p> |
| 33 | GR | Combination switch output 4 | Output | ON | Lighting, turn, wiper OFF Wiper dial position 4 |  <p style="text-align: right; font-size: small;">SKIA5292E</p> |
| 34 | G | Combination switch output 3 | Output | ON | Lighting, turn, wiper OFF Wiper dial position 4 |  <p style="text-align: right; font-size: small;">SKIA5291E</p> |
| 35 | BR | Combination switch output 2 | Output | ON | Lighting, turn, wiper OFF Wiper dial position 4 |  <p style="text-align: right; font-size: small;">SKIA5292E</p> |
| 36 | LG | Combination switch output 1 | | | | |
| 37 | B | Key switch and key lock solenoid | Input | OFF | Key inserted | Battery voltage |
| | | | | | Key removed | 0V |
| 38 | W/R | Ignition switch (ON) | Input | ON | — | Battery voltage |
| 39 | L | CAN-H | — | — | — | — |
| 40 | P | CAN-L | — | — | — | — |
| 41 | Y | Rear window defogger switch | Input | ON | Rear window defogger switch ON | 0V |
| | | | | | Rear window defogger switch OFF | 5V |
| 42 | L | Off-road lamps | Output | ON | Off-road lamps switch ON | 0V |
| | | | | | Off-road lamps switch OFF | Battery voltage |
| 43 | Y | Back door switch | Input | OFF | ON (open) | 0V |
| | | | | | OFF (closed) | Battery voltage |

BCM (BODY CONTROL MODULE)

< ECU DIAGNOSIS INFORMATION >

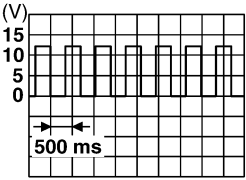
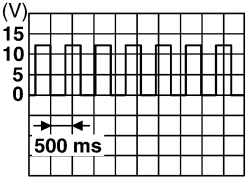
| Terminal | Wire color | Signal name | Signal input/output | Measuring condition | | Reference value or waveform (Approx.) |
|----------|------------|-----------------------------|---------------------|---------------------|--|---|
| | | | | Ignition switch | Operation or condition | |
| 44 | BG | Rear wiper auto stop switch | Input | ON | Rise up position (rear wiper arm on stopper) | 0V |
| | | | | | A Position (full clockwise stop position) | Battery voltage |
| | | | | | Forward sweep (counterclockwise direction) | Fluctuating |
| | | | | | B Position (full counterclockwise stop position) | 0V |
| | | | | | Reverse sweep (clockwise direction) | Fluctuating |
| 45 | V | Lock switch | Input | OFF | ON (lock) | 0V |
| | | | | | OFF | Battery voltage |
| 46 | LG | Unlock switch | Input | OFF | ON (unlock) | 0V |
| | | | | | OFF | Battery voltage |
| 47 | GR | Front door switch LH | Input | OFF | ON (open) | 0V |
| | | | | | OFF (closed) | Battery voltage |
| 48 | P | Rear door switch LH | Input | OFF | ON (open) | 0V |
| | | | | | OFF (closed) | Battery voltage |
| 49 | L | Cargo lamp | Output | OFF | Any door open (ON) | 0V |
| | | | | | All doors closed (OFF) | Battery voltage |
| 50 | W | Off-road lamps relay | Output | ON | Off-road lamps switch | ON OFF |
| | | | | | | 0V Battery voltage |
| 51 | BG | Trailer turn signal (right) | Output | ON | Turn right ON |  <p style="text-align: right; font-size: small;">SKIA3009J</p> |
| 52 | LG | Trailer turn signal (left) | Output | ON | Turn left ON |  <p style="text-align: right; font-size: small;">SKIA3009J</p> |
| 55 | W | Rear wiper output circuit 1 | Output | ON | OFF | 0 |
| | | | | | ON | Battery voltage |
| 56 | R/Y | Battery saver output | Output | OFF | 10 minutes after ignition switch is turned OFF | 0V |
| | | | | ON | — | Battery voltage |
| 57 | R/Y | Battery power supply | Input | OFF | — | Battery voltage |
| 58 | W | Optical sensor | Input | ON | When optical sensor is illuminated | 3.1V or more |
| | | | | | When optical sensor is not illuminated | 0.6V or less |

A
B
C
D
E
F
G
H
I
J
K
DEF
M
N
O
P

BCM (BODY CONTROL MODULE)

< ECU DIAGNOSIS INFORMATION >

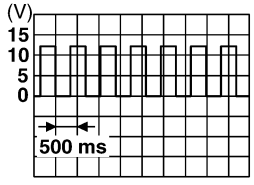
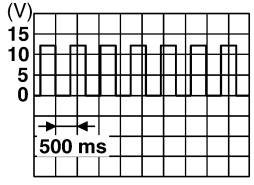
| Terminal | Wire color | Signal name | Signal input/output | Measuring condition | | Reference value or waveform (Approx.) | |
|----------|------------|--|---------------------|---------------------|---|---|----|
| | | | | Ignition switch | Operation or condition | | |
| 59 | GR | Front door lock assembly LH actuator (unlock) | Output | OFF | OFF (neutral) | 0V | |
| | | | | | ON (unlock) | Battery voltage | |
| 60 | LG | Turn signal (left) | Output | ON | Turn left ON |  | |
| 61 | G | Turn signal (right) | Output | ON | Turn right ON |  | |
| 63 | BR | Interior room/map lamp | Output | OFF | Any door switch | ON (open) | 0V |
| | | | | | OFF (closed) | Battery voltage | |
| 65 | V | All door lock actuators (lock) | Output | OFF | OFF (neutral) | 0V | |
| | | | | | ON (lock) | Battery voltage | |
| 66 | L | Front door lock actuator RH, rear door lock actuators LH/RH and back door lock actuator (unlock) | Output | OFF | OFF (neutral) | 0V | |
| | | | | | ON (unlock) | Battery voltage | |
| 67 | B | Ground | Input | ON | — | 0V | |
| 68 | SB | Power window power supply (RAP) | Output | — | Ignition switch ON | Battery voltage | |
| | | | | | Within 45 seconds after ignition switch OFF | Battery voltage | |
| | | | | | More than 45 seconds after ignition switch OFF | 0V | |
| | | | | | When front door LH or RH is open or power window timer operates | 0V | |
| 70 | W | Battery power supply | Input | OFF | — | Battery voltage | |

REAR WINDOW DEFOGGER

< WIRING DIAGRAM >

WIRING DIAGRAM

REAR WINDOW DEFOGGER

Wiring Diagram

INFOID:000000009484776

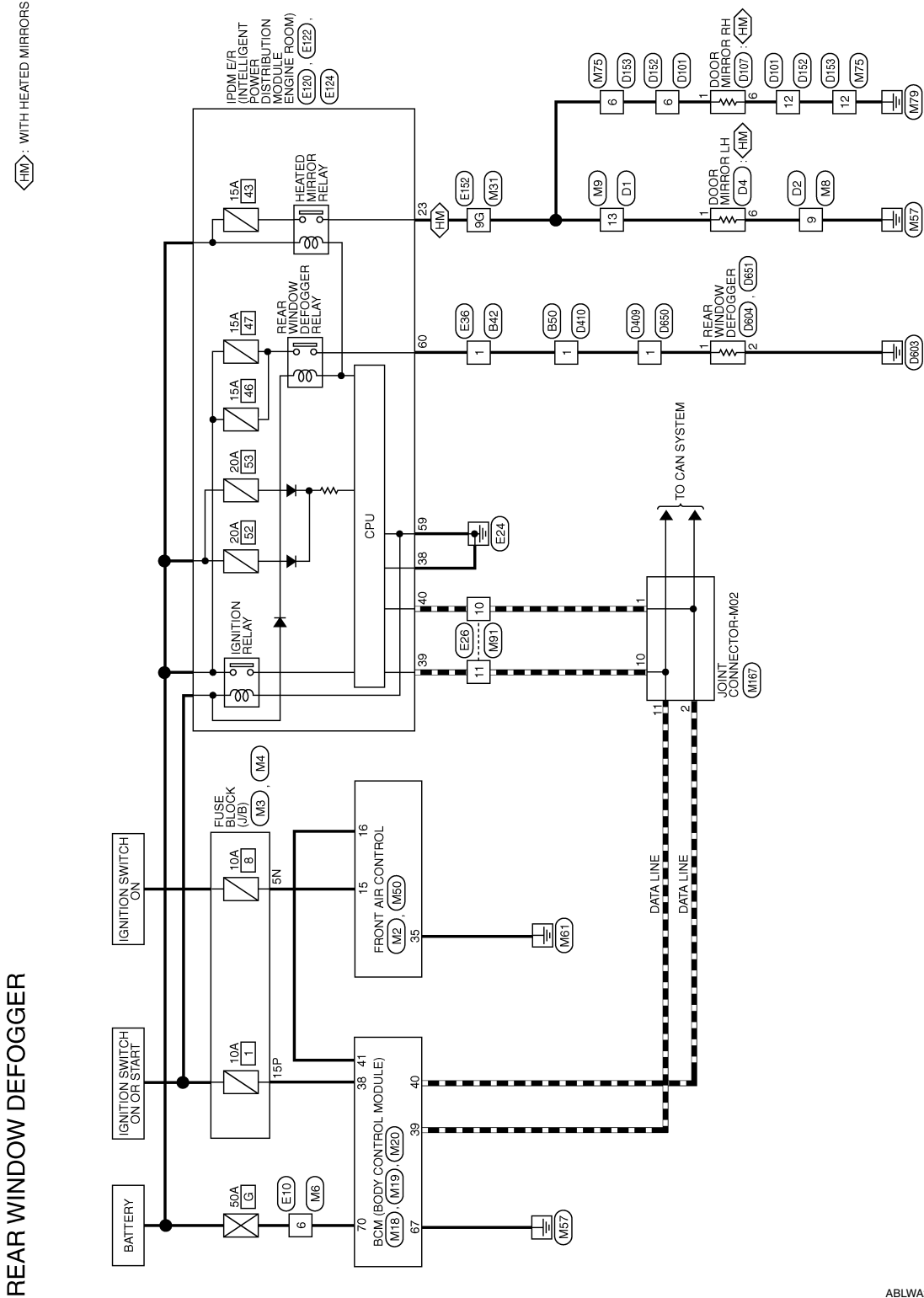

ABLWA2408GB

A
B
C
D
E
F
G
H
I
J
K
M
N
O
P

DEF

REAR WINDOW DEFOGGER

< WIRING DIAGRAM >

REAR WINDOW DEFOGGER CONNECTORS

| | |
|-----------------|-------------------|
| Connector No. | M2 |
| Connector Name | FRONT AIR CONTROL |
| Connector Color | WHITE |



| | | | | | |
|--------------|----|---------------|---|-------------|-----|
| Terminal No. | 35 | Color of Wire | B | Signal Name | GND |
|--------------|----|---------------|---|-------------|-----|

| | |
|-----------------|------------------|
| Connector No. | M3 |
| Connector Name | FUSE BLOCK (J/B) |
| Connector Color | WHITE |

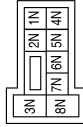

| | | | | | |
|--------------|----|---------------|-----|-------------|---|
| Terminal No. | 5N | Color of Wire | W/G | Signal Name | - |
|--------------|----|---------------|-----|-------------|---|

| | |
|-----------------|------------------|
| Connector No. | M4 |
| Connector Name | FUSE BLOCK (J/B) |
| Connector Color | WHITE |



| | | | | | |
|--------------|-----|---------------|-----|-------------|---|
| Terminal No. | 15P | Color of Wire | W/R | Signal Name | - |
|--------------|-----|---------------|-----|-------------|---|

| | |
|-----------------|--------------|
| Connector No. | M6 |
| Connector Name | WIRE TO WIRE |
| Connector Color | WHITE |



| | | | | | |
|--------------|---|---------------|---|-------------|---|
| Terminal No. | 6 | Color of Wire | W | Signal Name | - |
|--------------|---|---------------|---|-------------|---|

| | |
|-----------------|--------------|
| Connector No. | M8 |
| Connector Name | WIRE TO WIRE |
| Connector Color | BROWN |

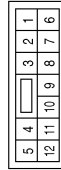

| | | | | | |
|--------------|---|---------------|---|-------------|---|
| Terminal No. | 9 | Color of Wire | B | Signal Name | - |
|--------------|---|---------------|---|-------------|---|

| | |
|-----------------|--------------|
| Connector No. | M9 |
| Connector Name | WIRE TO WIRE |
| Connector Color | WHITE |

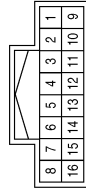

| | | | | | |
|--------------|----|---------------|----|-------------|---|
| Terminal No. | 13 | Color of Wire | LG | Signal Name | - |
|--------------|----|---------------|----|-------------|---|

REAR WINDOW DEFOGGER

< WIRING DIAGRAM >

| | |
|-----------------|---------------------------|
| Connector No. | M20 |
| Connector Name | BCM (BODY CONTROL MODULE) |
| Connector Color | BLACK |

| | | | | | | | | |
|----|----|----|----|----|----|----|----|----|
| 56 | 57 | 58 | 59 | 60 | 61 | 62 | 63 | 64 |
| 65 | 66 | 67 | 68 | 69 | 70 | | | |



| Terminal No. | Color of Wire | Signal Name |
|--------------|---------------|-------------|
| 67 | B | GND (POWER) |
| 70 | W | BAT (F/L) |

| | |
|-----------------|---------------------------|
| Connector No. | M19 |
| Connector Name | BCM (BODY CONTROL MODULE) |
| Connector Color | WHITE |

| | | | | | | | | |
|----|----|----|----|----|----|----|----|----|
| 41 | 42 | 43 | 44 | 45 | 46 | 47 | 48 | 49 |
| 50 | 51 | 52 | 53 | 54 | 55 | | | |



| Terminal No. | Color of Wire | Signal Name |
|--------------|---------------|------------------|
| 41 | Y | REAR DEFOGGER SW |

| | |
|-----------------|---------------------------|
| Connector No. | M18 |
| Connector Name | BCM (BODY CONTROL MODULE) |
| Connector Color | WHITE |



| | | | | | | | | | | | | | | | | | | | |
|----|----|----|----|----|----|----|----|----|----|----|----|----|----|----|----|----|----|----|----|
| 1 | 2 | 3 | 4 | 5 | 6 | 7 | 8 | 9 | 10 | 11 | 12 | 13 | 14 | 15 | 16 | 17 | 18 | 19 | 20 |
| 21 | 22 | 23 | 24 | 25 | 26 | 27 | 28 | 29 | 30 | 31 | 32 | 33 | 34 | 35 | 36 | 37 | 38 | 39 | 40 |

| Terminal No. | Color of Wire | Signal Name |
|--------------|---------------|-------------|
| 38 | W/R | IGN SW |
| 39 | L | CAN-H |
| 40 | P | CAN-L |

| | |
|-----------------|-------------------|
| Connector No. | M50 |
| Connector Name | FRONT AIR CONTROL |
| Connector Color | BLACK |

| | | | | | | | | | | | | |
|----|----|----|----|----|----|----|----|----|----|----|----|----|
| 13 | 12 | 11 | 10 | 9 | 8 | 7 | 6 | 5 | 4 | 3 | 2 | 1 |
| 26 | 25 | 24 | 23 | 22 | 21 | 20 | 19 | 18 | 17 | 16 | 15 | 14 |



| Terminal No. | Color of Wire | Signal Name |
|--------------|---------------|--------------|
| 15 | W/G | IGN |
| 16 | Y | REAR DEF REQ |

| | | | | | |
|--------------|----|---------------|----|-------------|---|
| Terminal No. | 9G | Color of Wire | LG | Signal Name | - |
|--------------|----|---------------|----|-------------|---|

| | |
|-----------------|--------------|
| Connector No. | M31 |
| Connector Name | WIRE TO WIRE |
| Connector Color | WHITE |

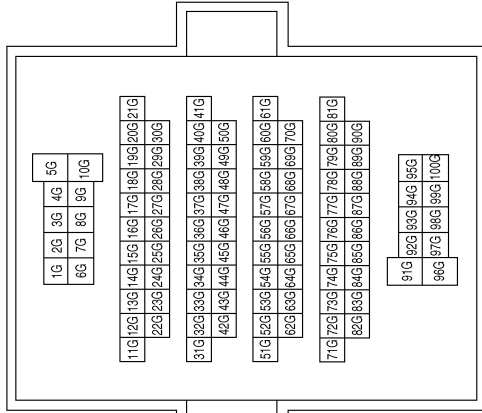

ABLIA5741GB

A
B
C
D
E
F
G
H
I
J
K
DEF
M
N
O
P

REAR WINDOW DEFOGGER

< WIRING DIAGRAM >

| | |
|-----------------|---------------------|
| Connector No. | M167 |
| Connector Name | JOINT CONNECTOR-M02 |
| Connector Color | BLUE |

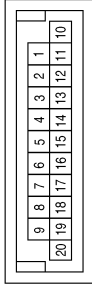

| Terminal No. | Color of Wire | Signal Name |
|--------------|---------------|-------------|
| 1 | P | - |
| 2 | P | - |
| 10 | L | - |
| 11 | L | - |

| | |
|-----------------|--------------|
| Connector No. | M91 |
| Connector Name | WIRE TO WIRE |
| Connector Color | WHITE |

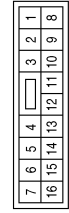

| Terminal No. | Color of Wire | Signal Name |
|--------------|---------------|-------------|
| 10 | P | - |
| 11 | L | - |

| | |
|-----------------|--------------|
| Connector No. | M75 |
| Connector Name | WIRE TO WIRE |
| Connector Color | WHITE |

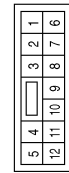

| Terminal No. | Color of Wire | Signal Name |
|--------------|---------------|-------------|
| 6 | L | - |
| 12 | B | - |

| | |
|-----------------|--------------|
| Connector No. | E36 |
| Connector Name | WIRE TO WIRE |
| Connector Color | WHITE |



| Terminal No. | Color of Wire | Signal Name |
|--------------|---------------|-------------|
| 1 | GR | - |

| | |
|-----------------|--------------|
| Connector No. | E26 |
| Connector Name | WIRE TO WIRE |
| Connector Color | WHITE |

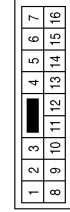

| Terminal No. | Color of Wire | Signal Name |
|--------------|---------------|-------------|
| 10 | P | - |
| 11 | L | - |

| | |
|-----------------|--------------|
| Connector No. | E10 |
| Connector Name | WIRE TO WIRE |
| Connector Color | WHITE |



| Terminal No. | Color of Wire | Signal Name |
|--------------|---------------|-------------|
| 6 | W | - |

ABLIA5742GB

REAR WINDOW DEFOGGER

< WIRING DIAGRAM >

| | |
|-----------------|--|
| Connector No. | E124 |
| Connector Name | IPDM E/R (INTELLIGENT POWER DISTRIBUTION MODULE ENGINE ROOM) |
| Connector Color | BLACK |



| Terminal No. | Color of Wire | Signal Name |
|--------------|---------------|-------------|
| 59 | B | GND (POWER) |
| 60 | GR | RR DEF |

| | |
|-----------------|--|
| Connector No. | E122 |
| Connector Name | IPDM E/R (INTELLIGENT POWER DISTRIBUTION MODULE ENGINE ROOM) |
| Connector Color | WHITE |

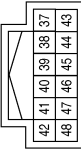

| Terminal No. | Color of Wire | Signal Name |
|--------------|---------------|--------------|
| 38 | B | GND (SIGNAL) |
| 39 | L | CAN-H |
| 40 | P | CAN-L |

| | |
|-----------------|--|
| Connector No. | E120 |
| Connector Name | IPDM E/R (INTELLIGENT POWER DISTRIBUTION MODULE ENGINE ROOM) |
| Connector Color | WHITE |

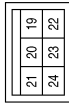

| Terminal No. | Color of Wire | Signal Name |
|--------------|---------------|---------------|
| 23 | LG | HEATED MIRROR |

| | |
|-----------------|--------------|
| Connector No. | B42 |
| Connector Name | WIRE TO WIRE |
| Connector Color | WHITE |



| Terminal No. | Color of Wire | Signal Name |
|--------------|---------------|-------------|
| 1 | GR | - |

| | | | | | |
|--------------|----|---------------|----|-------------|---|
| Terminal No. | 9G | Color of Wire | LG | Signal Name | - |
|--------------|----|---------------|----|-------------|---|

| | |
|-----------------|--------------|
| Connector No. | E152 |
| Connector Name | WIRE TO WIRE |
| Connector Color | WHITE |

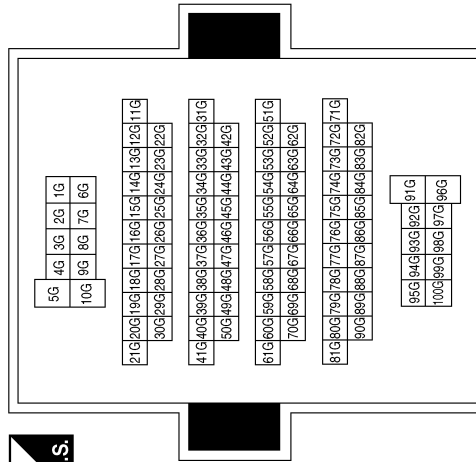

ABLIA5743GB

A
B
C
D
E
F
G
H
I
J
K
DEF
M
N
O
P

REAR WINDOW DEFOGGER

< WIRING DIAGRAM >

| | |
|-----------------|--------------|
| Connector No. | D2 |
| Connector Name | WIRE TO WIRE |
| Connector Color | BROWN |

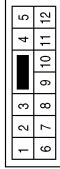

| | | | | | |
|--------------|---|---------------|---|-------------|---|
| Terminal No. | 9 | Color of Wire | B | Signal Name | - |
|--------------|---|---------------|---|-------------|---|

| | |
|-----------------|--------------|
| Connector No. | D1 |
| Connector Name | WIRE TO WIRE |
| Connector Color | WHITE |

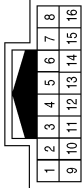

| | | | | | |
|--------------|----|---------------|-----|-------------|---|
| Terminal No. | 13 | Color of Wire | L/B | Signal Name | - |
|--------------|----|---------------|-----|-------------|---|

| | |
|-----------------|--------------|
| Connector No. | B50 |
| Connector Name | WIRE TO WIRE |
| Connector Color | WHITE |



| | | | | | |
|--------------|---|---------------|----|-------------|---|
| Terminal No. | 1 | Color of Wire | GR | Signal Name | - |
|--------------|---|---------------|----|-------------|---|

| | |
|-----------------|--------------------------------------|
| Connector No. | D107 |
| Connector Name | DOOR MIRROR RH (WITH HEATED MIRRORS) |
| Connector Color | BLACK |

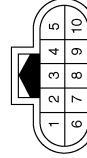

| | | | | | |
|--------------|---|---------------|-----|-------------|---|
| Terminal No. | 1 | Color of Wire | L/B | Signal Name | - |
| | 6 | | B | | - |

| | |
|-----------------|--------------|
| Connector No. | D101 |
| Connector Name | WIRE TO WIRE |
| Connector Color | WHITE |

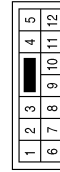

| | | | | | |
|--------------|----|---------------|-----|-------------|---|
| Terminal No. | 6 | Color of Wire | L/B | Signal Name | - |
| | 12 | | B | | - |

| | |
|-----------------|--------------------------------------|
| Connector No. | D4 |
| Connector Name | DOOR MIRROR LH (WITH HEATED MIRRORS) |
| Connector Color | BLACK |

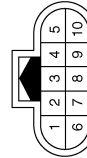

| | | | | | |
|--------------|---|---------------|-----|-------------|---|
| Terminal No. | 1 | Color of Wire | L/B | Signal Name | - |
| | 6 | | B | | - |

ABLIA5744GB

REAR WINDOW DEFOGGER

< WIRING DIAGRAM >

| | |
|-----------------|--------------|
| Connector No. | D409 |
| Connector Name | WIRE TO WIRE |
| Connector Color | WHITE |



| Terminal No. | Color of Wire | Signal Name |
|--------------|---------------|-------------|
| 1 | GR | - |

| | |
|-----------------|--------------|
| Connector No. | D153 |
| Connector Name | WIRE TO WIRE |
| Connector Color | WHITE |

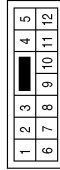

| Terminal No. | Color of Wire | Signal Name |
|--------------|---------------|-------------|
| 6 | L | - |
| 12 | B | - |

| | |
|-----------------|--------------|
| Connector No. | D152 |
| Connector Name | WIRE TO WIRE |
| Connector Color | WHITE |

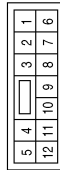

| Terminal No. | Color of Wire | Signal Name |
|--------------|---------------|-------------|
| 6 | L | - |
| 12 | B | - |

| | |
|-----------------|--------------|
| Connector No. | D650 |
| Connector Name | WIRE TO WIRE |
| Connector Color | WHITE |



| Terminal No. | Color of Wire | Signal Name |
|--------------|---------------|-------------|
| 1 | GR | - |

| | |
|-----------------|----------------------|
| Connector No. | D604 |
| Connector Name | REAR WINDOW DEFOGGER |
| Connector Color | BLACK |



| Terminal No. | Color of Wire | Signal Name |
|--------------|---------------|-------------|
| 2 | B | - |

| | |
|-----------------|--------------|
| Connector No. | D410 |
| Connector Name | WIRE TO WIRE |
| Connector Color | WHITE |



| Terminal No. | Color of Wire | Signal Name |
|--------------|---------------|-------------|
| 1 | GR | - |

ABLIA5745GB

A
B
C
D
E
F
G
H
I
J
K
DEF
M
N
O
P

REAR WINDOW DEFOGGER

< WIRING DIAGRAM >

| | |
|-----------------|----------------------|
| Connector No. | D651 |
| Connector Name | REAR WINDOW DEFOGGER |
| Connector Color | BLACK |



| Terminal No. | Color of Wire | Signal Name |
|--------------|---------------|-------------|
| 1 | GR | - |

ABLIA5746GB

REAR WINDOW DEFOGGER AND DOOR MIRROR DEFOGGER DO NOT OPERATE.

< SYMPTOM DIAGNOSIS >

SYMPTOM DIAGNOSIS

REAR WINDOW DEFOGGER AND DOOR MIRROR DEFOGGER DO NOT OPERATE.

Diagnosis Procedure

INFOID:000000009484777

1. CHECK REAR WINDOW DEFOGGER SWITCH

Check rear window defogger switch.

Refer to [DEF-8, "Component Function Check"](#).

Is the inspection result normal?

YES >> GO TO 2

NO >> Repair or replace the malfunctioning parts.

2. CHECK REAR WINDOW DEFOGGER RELAY

Check rear window defogger relay.

Refer to [DEF-9, "Component Function Check"](#).

Is the inspection result normal?

YES >> GO TO 3

NO >> Repair or replace the malfunctioning parts.

3. CHECK REAR WINDOW DEFOGGER POWER SUPPLY AND GROUND CIRCUIT

Check rear window defogger power supply and ground circuit.

Refer to [DEF-10, "Component Function Check"](#).

Is the inspection result normal?

YES >> GO TO 4

NO >> Repair or replace the malfunctioning parts.

4. CHECK BOTH DOOR MIRROR DEFOGGER

1. Check door mirror LH. Refer to [DEF-12, "Component Function Check"](#).

2. Check door mirror RH. Refer to [DEF-15, "Component Function Check"](#).

Is the inspection result normal?

YES >> Check intermittent incident. Refer to [GI-40, "Intermittent Incident"](#).

NO >> Repair or replace the malfunctioning parts.

A
B
C
D
E
F
G
H
I
J
K
M
N
O
P

DEF

REAR WINDOW DEFOGGER DOES NOT OPERATE BUT BOTH OF DOOR MIRROR DEFOGGER OPERATE.

< SYMPTOM DIAGNOSIS >

REAR WINDOW DEFOGGER DOES NOT OPERATE BUT BOTH OF DOOR MIRROR DEFOGGER OPERATE.

Diagnosis Procedure

INFOID:000000009484778

1. CHECK REAR WINDOW DEFOGGER POWER SUPPLY AND GROUND CIRCUIT

Check rear window defogger power supply and ground circuit.

Refer to [DEF-10, "Component Function Check"](#).

Is the inspection result normal?

YES >> Check for intermittent incident. Refer to [GI-40, "Intermittent Incident"](#).

NO >> Repair or replace the malfunctioning parts.

BOTH DOORS MIRROR DEFOGGER DON'T OPERATE BUT REAR WINDOW DEFOGGER OPERATES

< SYMPTOM DIAGNOSIS >

BOTH DOORS MIRROR DEFOGGER DON'T OPERATE BUT REAR WINDOW DEFOGGER OPERATES

Diagnosis Procedure

INFOID:000000009484779

1. CHECK BOTH DOOR MIRROR DEFOGGER

1. Check door mirror LH. Refer to [DEF-12, "Component Function Check"](#).
2. Check door mirror RH. Refer to [DEF-15, "Component Function Check"](#).

Is the inspection result normal?

- YES >> Check intermittent incident. Refer to [GI-40, "Intermittent Incident"](#).
NO >> Repair or replace the malfunctioning parts.

A
B
C
D
E
F
G
H
I
J
K
DEF
M
N
O
P

DRIVER SIDE DOOR MIRROR DEFOGGER DOES NOT OPERATE.

< SYMPTOM DIAGNOSIS >

DRIVER SIDE DOOR MIRROR DEFOGGER DOES NOT OPERATE.

Diagnosis Procedure

INFOID:000000009484780

1. CHECK DOOR MIRROR DEFOGGER LH

Check door mirror defogger LH.

Refer to [DEF-12, "Component Function Check"](#).

Is the inspection result normal?

YES >> Check for intermittent incident. Refer to [GI-40, "Intermittent Incident"](#).

NO >> Repair or replace the malfunctioning parts.

PASSENGER SIDE DOOR MIRROR DEFOGGER DOES NOT OPERATE.

< SYMPTOM DIAGNOSIS >

PASSENGER SIDE DOOR MIRROR DEFOGGER DOES NOT OPERATE.

Diagnosis Procedure

INFOID:000000009484781

1. CHECK DOOR MIRROR DEFOGGER RH

Check door mirror defogger RH.

Refer to [DEF-15, "Component Function Check"](#).

Is the inspection result normal?

YES >> Check for intermittent incident. Refer to [GI-40, "Intermittent Incident"](#).

NO >> Repair or replace the malfunctioning parts.

A
B
C
D
E
F
G
H
I
J
K
DEF
M
N
O
P

REAR WINDOW DEFOGGER SWITCH DOES NOT LIGHT, BUT REAR WINDOW DEFOGGER OPERATES

< SYMPTOM DIAGNOSIS >

REAR WINDOW DEFOGGER SWITCH DOES NOT LIGHT, BUT REAR WINDOW DEFOGGER OPERATES

Diagnosis Procedure

INFOID:000000009484782

1. CHECK REAR WINDOW DEFOGGER SWITCH

Check that the rear window defogger switch is operating normally.

Is the inspection result normal?

- YES >> Check for intermittent incident. Refer to [GI-40, "Intermittent Incident"](#).
- NO >> Check rear window defogger switch. Refer to [DEF-8, "Diagnosis Procedure"](#) .

PRECAUTIONS

< PRECAUTION >

PRECAUTION

PRECAUTIONS

Precaution for Supplemental Restraint System (SRS) "AIR BAG" and "SEAT BELT PRE-TENSIONER"

INFOID:000000010199586

The Supplemental Restraint System such as "AIR BAG" and "SEAT BELT PRE-TENSIONER", used along with a front seat belt, helps to reduce the risk or severity of injury to the driver and front passenger for certain types of collision. This system includes seat belt switch inputs and dual stage front air bag modules. The SRS system uses the seat belt switches to determine the front air bag deployment, and may only deploy one front air bag, depending on the severity of a collision and whether the front occupants are belted or unbelted. Information necessary to service the system safely is included in the SR and SB section of this Service Manual.

WARNING:

- To avoid rendering the SRS inoperative, which could increase the risk of personal injury or death in the event of a collision which would result in air bag inflation, all maintenance must be performed by an authorized NISSAN/INFINITI dealer.
- Improper maintenance, including incorrect removal and installation of the SRS, can lead to personal injury caused by unintentional activation of the system. For removal of Spiral Cable and Air Bag Module, see the SR section.
- Do not use electrical test equipment on any circuit related to the SRS unless instructed to in this Service Manual. SRS wiring harnesses can be identified by yellow and/or orange harnesses or harness connectors.

PRECAUTIONS WHEN USING POWER TOOLS (AIR OR ELECTRIC) AND HAMMERS

WARNING:

- When working near the Airbag Diagnosis Sensor Unit or other Airbag System sensors with the Ignition ON or engine running, DO NOT use air or electric power tools or strike near the sensor(s) with a hammer. Heavy vibration could activate the sensor(s) and deploy the air bag(s), possibly causing serious injury.
- When using air or electric power tools or hammers, always switch the Ignition OFF, disconnect the battery and wait at least three minutes before performing any service.

Handling for Adhesive and Primer

INFOID:000000009484784

- Do not use an adhesive which is past its usable date. Shelf life of this product is limited to six months after the date of manufacture. Carefully adhere to the expiration or manufacture date printed on the box.
- Keep primers and adhesive in a cool, dry place. Ideally, they should be stored in a refrigerator.
- Open the seal of the primer and adhesive just before application. Discard the remainder.
- Before application, be sure to shake the primer container to stir the contents. If any floating material is found, do not use it.
- If any primer or adhesive contacts the skin, wipe it off with gasoline or equivalent and wash the skin with soap.
- When using primer and adhesive, always observe the precautions in the instruction manual.

A
B
C
D
E
F
G
H
I
J
K
DEF
M
N
O
P

REAR WINDOW DEFOGGER

< REMOVAL AND INSTALLATION >

REMOVAL AND INSTALLATION

REAR WINDOW DEFOGGER

Filament Check

INFOID:000000009484785

1. When measuring voltage, wrap tin foil around the top of the negative probe. Then press the foil against the wire with your finger.

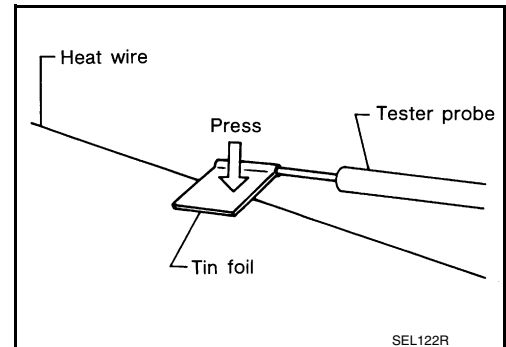

2. Attach probe circuit tester (in Volt range) to middle portion of each filament.

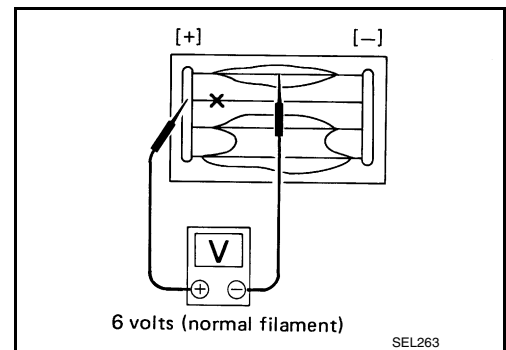

3. If a filament is burned out, circuit tester registers 0 or battery voltage.
4. To locate burned out point, move probe to left and right along filament. Test needle will swing abruptly when probe passes the point.

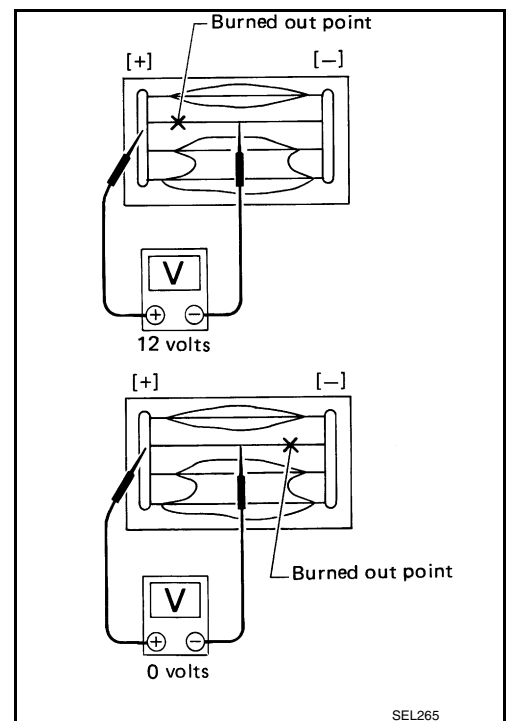

Filament Repair

INFOID:000000009484786

REPAIR EQUIPMENT

- Conductive silver composition (DuPont No. 4817 or equivalent)
- Ruler 30 cm (11.8 in) long

REAR WINDOW DEFOGGER

< REMOVAL AND INSTALLATION >

- Drawing pen
- Heat gun
- Alcohol
- Cloth

REPAIRING PROCEDURE

1. Wipe broken heat wire and its surrounding area clean with a cloth dampened in alcohol.
2. Apply a small amount of conductive silver composition to tip of drawing pen.

NOTE:

Shake silver composition container before use.

3. Place ruler on glass along broken line. Deposit conductive silver composition on break with drawing pen. Slightly overlap existing heat wire on both sides [preferably 5 mm (0.20 in)] of the break.

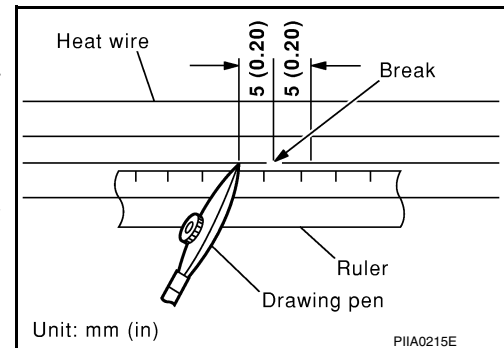

4. After repair has been completed, check repaired wire for continuity. This check should be conducted 10 minutes after silver composition is deposited.

CAUTION:

Do not touch repaired area while test is being conducted.

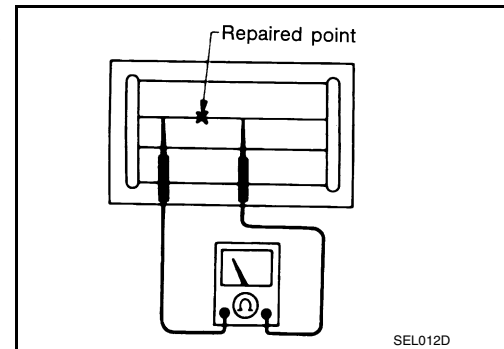

5. Apply a constant stream of hot air directly to the repaired area for approximately 20 minutes with a heat gun. A minimum distance of 3 cm (1.2 in) should be kept between repaired area and hot air outlet.

NOTE:

If a heat gun is not available, let the repaired area dry for 24 hours.

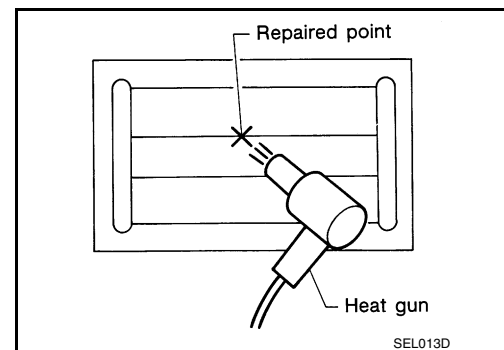

A
B
C
D
E
F
G
H
I
J
K
DEF
M
N
O
P