

SECTION **RAX**  
REAR AXLE

A  
B  
C

RAX

CONTENTS

E

**C200**

**PRECAUTION** ..... 3

**PRECAUTIONS** ..... 3

    Caution for Supplemental Restraint System (SRS) "AIR BAG" and "SEAT BELT PRE-TENSIONER" ..... 3

    Caution ..... 3

**PREPARATION** ..... 4

**PREPARATION** ..... 4

    Special Service Tool ..... 4

    Commercial Service Tool ..... 4

**SYMPTOM DIAGNOSIS** ..... 6

**NOISE, VIBRATION AND HARSHNESS (NVH) TROUBLESHOOTING** ..... 6

    NVH Troubleshooting Chart ..... 6

**REMOVAL AND INSTALLATION** ..... 7

**ON-VEHICLE SERVICE** ..... 7

    Rear Axle Parts ..... 7

    Rear Axle Bearing ..... 7

**UNIT REMOVAL AND INSTALLATION** ..... 8

**AXLE SHAFT** ..... 8

    Removal and Installation ..... 8

**AXLE BEARING** ..... 13

    Removal and Installation ..... 13

**AXLE OIL SEAL** ..... 14

    Removal and Installation ..... 14

**SERVICE DATA AND SPECIFICATIONS (SDS)** ..... 15

**SERVICE DATA AND SPECIFICATIONS (SDS)** ..... 15

    Axle Specification ..... 15

    Shim Washers ..... 15

**M226**

**PRECAUTION** ..... 16

**PRECAUTIONS** ..... 16

    Caution for Supplemental Restraint System (SRS) "AIR BAG" and "SEAT BELT PRE-TENSIONER" ..... 16

    Caution ..... 16

**PREPARATION** ..... 17

**PREPARATION** ..... 17

    Special Service Tool ..... 17

    Commercial Service Tool ..... 17

**SYMPTOM DIAGNOSIS** ..... 18

**NOISE, VIBRATION AND HARSHNESS (NVH) TROUBLESHOOTING** ..... 18

    NVH Troubleshooting Chart ..... 18

**REMOVAL AND INSTALLATION** ..... 19

**ON-VEHICLE SERVICE** ..... 19

    Rear Axle Parts ..... 19

    Rear Axle Bearing ..... 19

**UNIT REMOVAL AND INSTALLATION** ..... 20

**AXLE SHAFT** ..... 20

    Removal and Installation ..... 20

**AXLE BEARING** ..... 24

    Removal and Installation ..... 24

**AXLE OIL SEAL** ..... 25

    Removal and Installation ..... 25

F  
G  
H  
I  
J  
K  
L  
M  
N  
O  
P

---

**SERVICE DATA AND SPECIFICATIONS**  
**(SDS)** ..... 26

**SERVICE DATA AND SPECIFICATIONS**  
**(SDS)** ..... 26  
Axle Bearing ..... 26

# PRECAUTION

## PRECAUTIONS

### Precaution for Supplemental Restraint System (SRS) "AIR BAG" and "SEAT BELT PRE-TENSIONER"

INFOID:000000010202611

The Supplemental Restraint System such as "AIR BAG" and "SEAT BELT PRE-TENSIONER", used along with a front seat belt, helps to reduce the risk or severity of injury to the driver and front passenger for certain types of collision. This system includes seat belt switch inputs and dual stage front air bag modules. The SRS system uses the seat belt switches to determine the front air bag deployment, and may only deploy one front air bag, depending on the severity of a collision and whether the front occupants are belted or unbelted. Information necessary to service the system safely is included in the SR and SB section of this Service Manual.

**WARNING:**

- To avoid rendering the SRS inoperative, which could increase the risk of personal injury or death in the event of a collision which would result in air bag inflation, all maintenance must be performed by an authorized NISSAN/INFINITI dealer.
- Improper maintenance, including incorrect removal and installation of the SRS, can lead to personal injury caused by unintentional activation of the system. For removal of Spiral Cable and Air Bag Module, see the SR section.
- Do not use electrical test equipment on any circuit related to the SRS unless instructed to in this Service Manual. SRS wiring harnesses can be identified by yellow and/or orange harnesses or harness connectors.

### PRECAUTIONS WHEN USING POWER TOOLS (AIR OR ELECTRIC) AND HAMMERS

**WARNING:**

- When working near the Airbag Diagnosis Sensor Unit or other Airbag System sensors with the Ignition ON or engine running, DO NOT use air or electric power tools or strike near the sensor(s) with a hammer. Heavy vibration could activate the sensor(s) and deploy the air bag(s), possibly causing serious injury.
- When using air or electric power tools or hammers, always switch the Ignition OFF, disconnect the battery and wait at least three minutes before performing any service.

### Precaution

INFOID:000000009484498

- When installing rubber parts, final tightening must be carried out under unladen condition\* with tires on ground.
  - \*: Fuel, radiator coolant and engine oil full. Spare tire, jack, hand tools and mats in designated positions.
- Use flare nut wrench when removing and installing brake tubes.
- After installing removed suspension parts, check wheel alignment and adjust if necessary.
- Always torque brake lines when installing.

A  
B  
C  
RAX  
E  
F  
G  
H  
I  
J  
K  
L  
M  
N  
O  
P

# PREPARATION

[C200]

< PREPARATION >

## PREPARATION

### PREPARATION

#### Special Service Tool

INFOID:000000009484499

The actual shape of the tools may differ from those illustrated here.

Tool number (TechMate No.) Tool name	Description
KV40106500 (J-45073) Rear axle bearing remover	Removing wheel bearing, wheel bearing lock nut and ABS sensor rotor
— (J-46215) Rear axle bearing installation kit A: ABS sensor mount repair kit J-46215-8 B: Plastic plugs and nuts kit J-46215-4	Installing rear axle bearing
— (J-23907) Seal and bushing puller	Removing rear axle seal

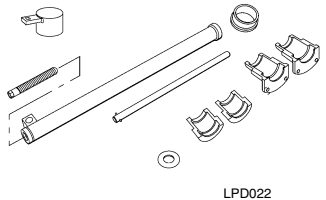

LPD022



LDIA0045E

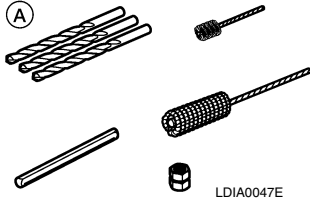

LDIA0047E

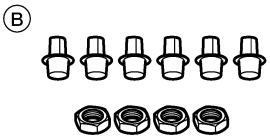

LDIA0048E

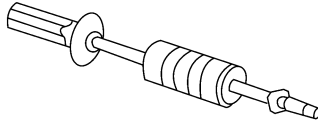

LDIA0046E



#### Commercial Service Tool

INFOID:000000009484500

# PREPARATION

[C200]

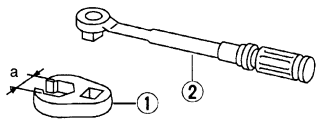
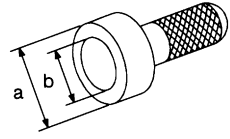
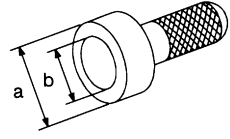
< PREPARATION >

Tool name	Description
<p>1 Flare nut crowfoot 2 Torque wrench</p>  <p>S-NT360</p>	<p>Removing and installing each brake piping <b>a: 10 mm (0.39 in)</b></p>
<p>Bearing cage oil seal drift</p>  <p>NT115</p>	<p>Installing oil seal <b>a: 74 mm (2.91 in) dia.</b> <b>b: 68 mm (2.68 in) dia.</b></p>
<p>Rear axle oil seal drift</p>  <p>NT115</p>	<p>Installing oil seal <b>a: 54.5 mm (2.15 in.)</b> <b>b: 34.5 mm (1.36 in.)</b></p>
<p>Power tool</p>  <p>PIIB1407E</p>	<p>Loosening nuts, screws and bolts</p>

A  
B  
C  
RAX  
E  
F  
G  
H  
I  
J  
K  
L  
M  
N  
O  
P

# NOISE, VIBRATION AND HARSHNESS (NVH) TROUBLESHOOTING

< SYMPTOM DIAGNOSIS >

[C200]

## SYMPTOM DIAGNOSIS

### NOISE, VIBRATION AND HARSHNESS (NVH) TROUBLESHOOTING

#### NVH Troubleshooting Chart

INFOID:000000009484501

Use the chart below to help you find the cause of the symptom. If necessary, repair or replace these parts.

Reference page		<a href="#">RAX-8</a>	<a href="#">RAX-8</a>	<a href="#">RAX-8</a>	<a href="#">DLN-138, "NVH Troubleshooting Chart"</a>	<a href="#">DLN-224, "NVH Troubleshooting Chart"</a>	<a href="#">RSU-4, "NVH Troubleshooting Chart"</a>	<a href="#">WT-44, "NVH Troubleshooting Chart"</a>	<a href="#">WT-44, "NVH Troubleshooting Chart"</a>	<a href="#">BR-5, "NVH Troubleshooting Chart"</a>
Possible cause and SUSPECTED PARTS	Improper installation, looseness	Parts interference	Wheel bearing damage	PROPELLER SHAFT	REAR FINAL DRIVE	SUSPENSION	TIRES	ROAD WHEEL	BRAKES	
Symptom	Noise	x	x		x	x	x	x	x	
	Shake	x	x		x		x	x	x	
	Vibration	x	x		x		x	x		
	Shimmy	x	x				x	x	x	
	Shudder	x					x	x	x	
	Poor quality ride or handling	x	x	x			x	x	x	

x: Applicable

## REMOVAL AND INSTALLATION

### ON-VEHICLE SERVICE

#### Rear Axle Parts

INFOID:000000009484502

- Check the axle parts for excessive play, wear and damage. Replace as necessary.
- Shake each rear wheel to check for excessive play. Repair as necessary.
- Retighten all nuts and bolts to the specified torque. Refer to [RAX-8](#).

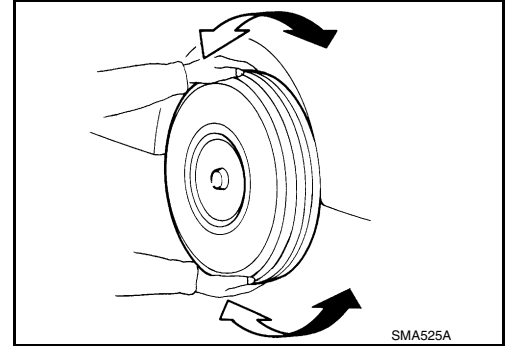

#### Rear Axle Bearing

INFOID:000000009484503

- Check that the axle shaft bearing operates smoothly. Replace as necessary.
- Check axial end play. Refer to [RAX-15, "Axle Specification"](#).

A  
B  
C  
RAX  
E  
F  
G  
H  
I  
J  
K  
L  
M  
N  
O  
P

# AXLE SHAFT

< UNIT REMOVAL AND INSTALLATION >

[C200]

## UNIT REMOVAL AND INSTALLATION

### AXLE SHAFT

#### Removal and Installation

INFOID:000000009484504

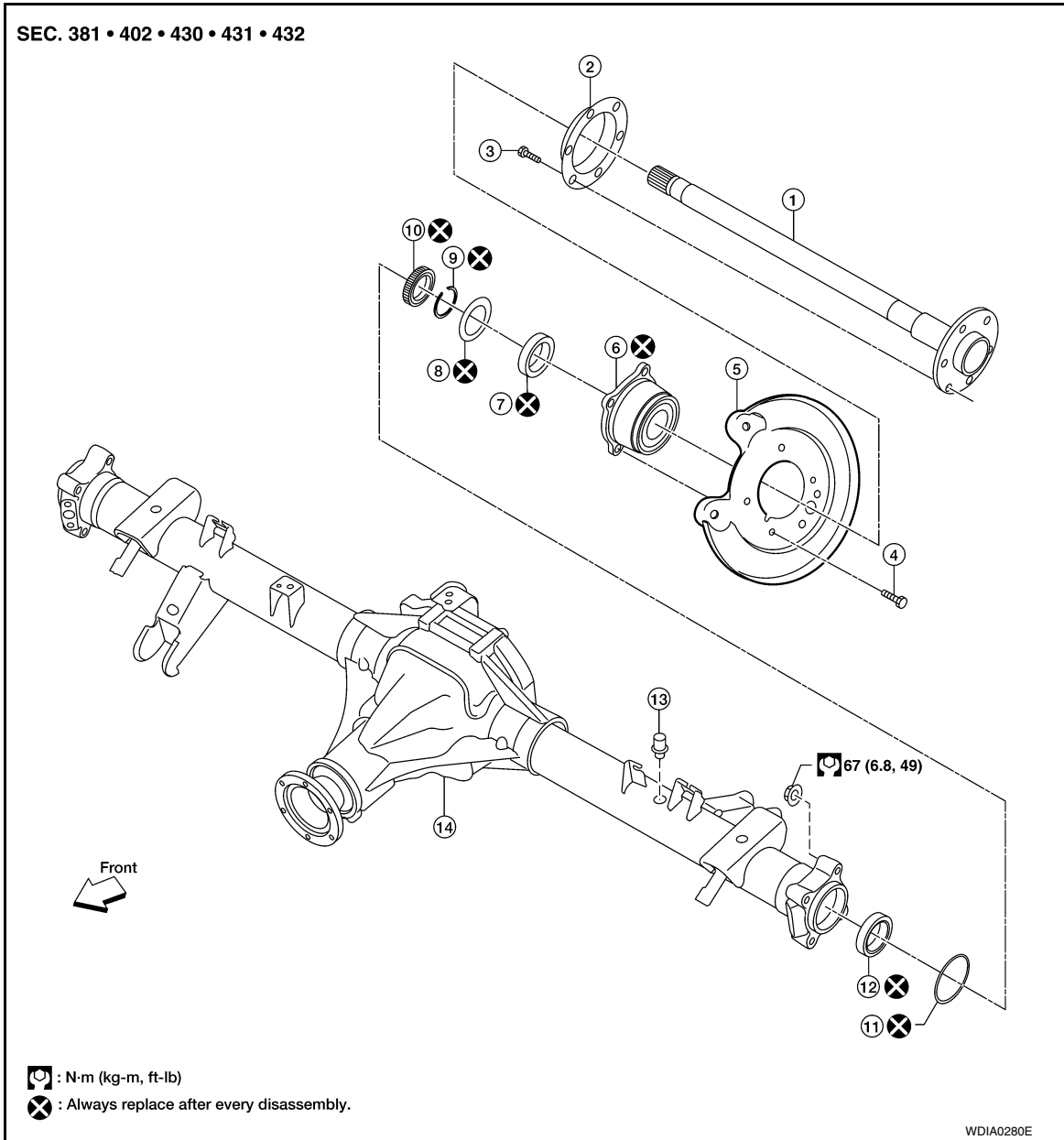

- |                          |                                 |                   |
|--------------------------|---------------------------------|-------------------|
| 1. Axle shaft            | 2. Grease catcher               | 3. Wheel stud     |
| 4. Axle bearing stud     | 5. Back plate and torque member | 6. Axle bearing   |
| 7. Bearing ring retainer | 8. Shim washer                  | 9. Snap ring      |
| 10. Wheel sensor rotor   | 11. O-ring                      | 12. Axle oil seal |
| 13. Breather             | 14. Rear final drive            |                   |

#### CAUTION:

**Before removing the rear axle, disconnect the wheel sensor from the assembly. Then move it away from the axle. Failure to do so may result in damage to the sensor wires and the sensor becoming inoperative.**

- Wheel bearing does not require maintenance.
- If growling noise is emitted from wheel bearing during operation, replace wheel bearing assembly.



# AXLE SHAFT

[C200]

## < UNIT REMOVAL AND INSTALLATION >

- If the wheel bearing assembly is removed, it must be replaced. The old assembly must not be re-used.

### REMOVAL

1. Remove the wheel and tire from the vehicle using power tool. Refer to [WT-48, "Adjustment"](#).
2. Remove the wheel sensor from the axle case and reposition out of the way. Refer to [BRC-112, "Removal and Installation"](#) (TYPE 1).
3. Without disassembling the hydraulic lines, remove the brake caliper using power tool. Position it aside with wire. Refer to [BR-39, "Removal and Installation of Brake Caliper and Disc Rotor"](#).
4. Put alignment marks on the disc rotor and wheel hub and bearing assembly, then remove the disc rotor.
5. Remove the parking brake assembly from the back plate and torque member. Refer to [PB-7, "Removal and Installation"](#).
6. Remove the axle bearing nuts securing the axle shaft assembly to the axle case.
7. Draw the axle shaft assembly out of the axle case using suitable tool.
8. Remove the O-ring.

**CAUTION:**

**Do not reuse O-ring.**

9. Remove the axle oil seal using Tools as shown.

**Tool number (A): — (J-26941 part of J-46215)**  
**(B): — (J-23907)**

- Do not reuse the axle oil seal once it is removed. Always install a new axle oil seal.
- Apply a constant pressure on the slide hammer while turning the slide hammer 180° periodically while pulling the axle oil seal out.

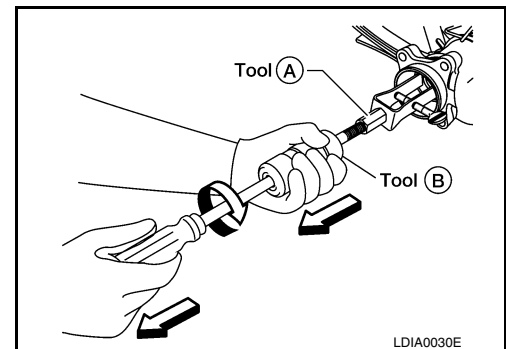

10. Remove the wheel sensor rotor using Tool. Discard the wheel sensor rotor.

**Tool number : KV40106500 (J-45073)**

**CAUTION:**

**Do not reuse wheel sensor rotor.**

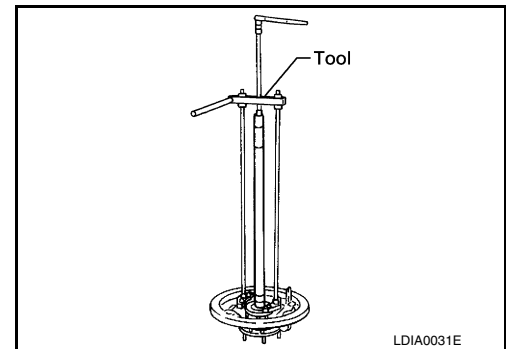

11. Remove the snap ring and shim washer. Discard the snap ring and shim washer.

**CAUTION:**

**Do not reuse snap ring and shim washer.**

12. Remove the bearing ring retainer from the axle shaft using Tool as shown. Discard the bearing ring retainer.

**Tool number : KV40106500 (J-45073)**

**CAUTION:**

**Do not reuse bearing ring retainer.**

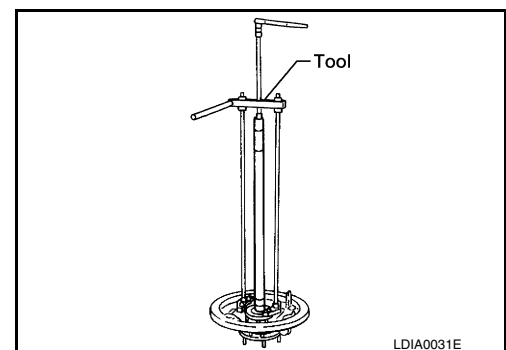

13. Remove the back plate and torque member with the axle bearing attached from the axle shaft using a suitable press.

A  
B  
C  
RAX  
E  
F  
G  
H  
I  
J  
K  
L  
M  
N  
O  
P

# AXLE SHAFT

[C200]

## < UNIT REMOVAL AND INSTALLATION >

14. Remove the axle bearing studs to release the axle bearing from the back plate and torque member using a suitable hammer or press.
15. Remove the wheel studs using a suitable hammer or press.
16. Remove the grease catcher from the axle shaft.

## INSPECTION AFTER REMOVAL

### Axle Shaft

- Check axle shaft for straightness, cracks, damage, wear and distortion. Replace if necessary.

### Axle Case

- Check axle case for yield, deformation and cracks. Replace if necessary. Refer to [DLN-198. "Removal and Installation"](#).

## INSTALLATION

1. Install the grease catcher on the axle shaft.
2. Install the wheel studs through the grease catcher into the axle shaft using a suitable press.  
**NOTE:**  
All six wheel studs must be pressed on at the same time and are flush with the grease catcher when installed.
3. Position the new axle bearing on the back plate and torque member.
4. Install the axle bearing studs using a suitable press to attach the axle bearing to the back plate and torque member.  
**CAUTION:**  
**Do not reuse axle bearing.**
5. Install the back plate and torque member, new axle bearing and new bearing ring retainer on the axle shaft using a suitable press.

**Maximum press load "P1" : 98 kN (10 ton, 11.0 US ton, 9.8 Imp ton)**

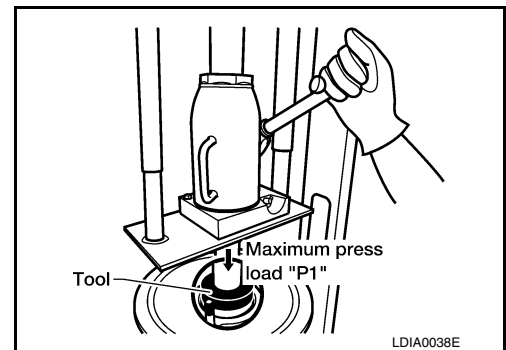

### **CAUTION:**

- Press the new bearing ring retainer on the axle shaft with the taper side positioned as shown.
- Do not reuse bearing ring retainer.

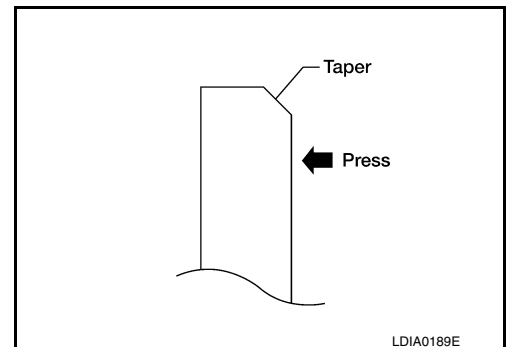

6. Select the correct size shim washer. Refer to [RAX-15. "Shim Washers"](#).
  - Select the size of shim washer so that the installed snap ring to shim washer clearance is within specification.

**Snap ring to shim washer clearance : Refer to [RAX-15. "Axle Specification"](#).**

### **CAUTION:**

**Do not reuse shim washer.**

7. Install a new snap ring on the axle shaft.

# AXLE SHAFT

[C200]

## < UNIT REMOVAL AND INSTALLATION >

- Do not over spread the snap ring when installing, measure the outer diameter of the snap ring after installation and replace if the snap ring outer diameter exceeds specification.

**Snap ring outer diameter installed** : Refer to [RAX-15, "Axle Specification"](#).

### CAUTION:

**Do not reuse snap ring.**

8. Check the snap ring to shim washer clearance, repeat steps 7 and 8 as necessary until the installed snap ring to shim washer clearance is within specification.
9. Perform break-in rotation of the wheel bearing.
  - a. Rotate the wheel bearing in the forward direction for a minimum of 10 revolutions at 50-70 RPM.
  - b. Rotate the wheel bearing in the reverse direction for a minimum of 10 revolutions at 50-70 RPM.
10. Measure the rotational torque of the wheel bearing.

**Rotational speed** : 8-12 RPM

**Rotational torque** : 1.8 N·m (0.18 kg·m, 16 in·lb)

11. Inspect that the wheel bearing is free from axial play relative to the axle shaft.
12. Install a new wheel sensor rotor on the axle shaft using a suitable press.

### CAUTION:

- Press the new wheel sensor rotor on the axle shaft with the notch side positioned as shown.
- Do not reuse wheel sensor rotor.

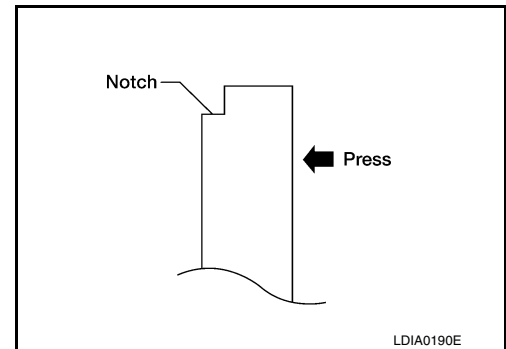

13. Install the new axle oil seal into the axle case using Tool as shown.
  - After installing the new oil seal, coat the sealing lip with oil.
  - Install the new oil seal with the seal facing outwards so that the seal is fully seated in the axle case.

**Tool number** : — (J-34115 part of J-46215)

### CAUTION:

**Do not reuse axle oil seal.**

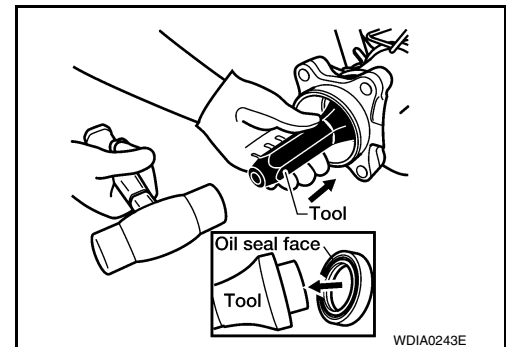

14. Apply multi-purpose grease to the recess of axle case end as shown.
15. Apply gear oil to the spline of axle shaft. Coat the axle oil seal surface of axle shaft with multi-purpose grease as shown.

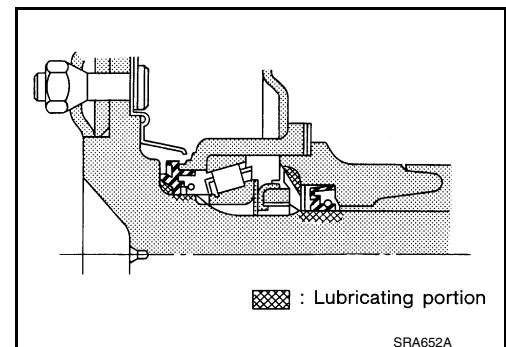

## AXLE SHAFT

### < UNIT REMOVAL AND INSTALLATION >

[C200]

16. Insert Tool into the new axle oil seal as a guide.

**CAUTION:**

**When inserting axle shaft, be careful not to damage oil seal.**

**NOTE:**

The split ends of the Tool must butt up together and not overlap as shown.

**Tool number** : — (J-34296-1 part of J-46215)

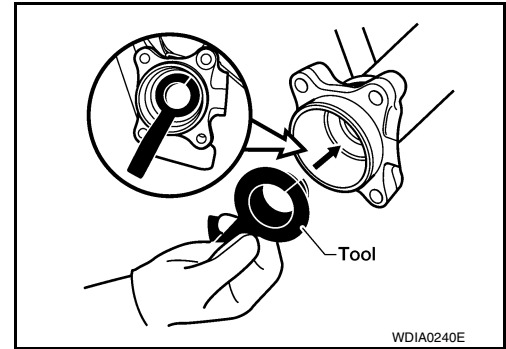

17. Insert the axle shaft assembly. Tighten the axle shaft nuts evenly in a criss-cross pattern to specification.
- Remove the Tool when the axle shaft assembly is approximately 90% inserted to protect the new axle oil seal.

**Tool number** : — (J-34296-1 part of J-46215)

18. Install the parking brake assembly on the back plate and torque member. Refer to [PB-7, "Removal and Installation"](#).
19. Install the rear brake caliper assembly. Refer to [BR-39, "Removal and Installation of Brake Caliper and Disc Rotor"](#).
20. Install the wheel sensor into the axle case. Refer to [BRC-112, "Removal and Installation"](#) (TYPE 1).
21. Install the wheel and tire. Refer to [WT-48, "Adjustment"](#).

# AXLE BEARING

< UNIT REMOVAL AND INSTALLATION >

[C200]

## AXLE BEARING

### Removal and Installation

INFOID:000000009484505

The axle bearing must be replaced every time the axle shaft is removed and installed. Refer to [RAX-8](#), "[Removal and Installation](#)".

**CAUTION:**

**Do not reuse the axle bearing.**

A  
B  
C  
E  
F  
G  
H  
I  
J  
K  
L  
M  
N  
O  
P

RAX

## AXLE OIL SEAL

< UNIT REMOVAL AND INSTALLATION >

[C200]

---

### AXLE OIL SEAL

#### Removal and Installation

INFOID:000000009484506

The axle oil seal must be replaced every time the axle shaft is removed and installed. Refer to [RAX-8, "Removal and Installation"](#).

**CAUTION:**

**Do not reuse the axle oil seal.**

# SERVICE DATA AND SPECIFICATIONS (SDS)

< SERVICE DATA AND SPECIFICATIONS (SDS)

[C200]

## SERVICE DATA AND SPECIFICATIONS (SDS)

### SERVICE DATA AND SPECIFICATIONS (SDS)

#### Axle Specification

INFOID:000000009484507

Unit: mm (in)

Axial end play	0 - 0.07 (0 - 0.003)
Snap ring to shim washer clearance	0.2 (0.008) or less
Snap ring outer diameter installed	47.5 (1.87) maximum

#### Shim Washers

INFOID:000000009484508

Unit: mm (in)

Total end play	0.02 - 0.15 (0.0008 - 0.0059)		
Available shim washers	ID Paint Dot Color	Thickness	Part Number*
	Pink	2.5 (0.098)	43086-EB08C
	Black	2.4 (0.094)	43086-EB07C
	Purple	2.3 (0.091)	43086-EB06C
	Yellow	2.2 (0.087)	43086-EB05C
	Green	2.1 (0.083)	43086-EB04C
	Red	2.0 (0.079)	43086-EB03C
	White	1.9 (0.075)	43086-EB02C
	Blue	1.8 (0.071)	43086-EB01C

\*: Always check with the Parts Department for the latest parts information.

## PRECAUTION

### PRECAUTIONS

#### Precaution for Supplemental Restraint System (SRS) "AIR BAG" and "SEAT BELT PRE-TENSIONER"

INFOID:000000010202791

The Supplemental Restraint System such as "AIR BAG" and "SEAT BELT PRE-TENSIONER", used along with a front seat belt, helps to reduce the risk or severity of injury to the driver and front passenger for certain types of collision. This system includes seat belt switch inputs and dual stage front air bag modules. The SRS system uses the seat belt switches to determine the front air bag deployment, and may only deploy one front air bag, depending on the severity of a collision and whether the front occupants are belted or unbelted. Information necessary to service the system safely is included in the SR and SB section of this Service Manual.

**WARNING:**

- To avoid rendering the SRS inoperative, which could increase the risk of personal injury or death in the event of a collision which would result in air bag inflation, all maintenance must be performed by an authorized NISSAN/INFINITI dealer.
- Improper maintenance, including incorrect removal and installation of the SRS, can lead to personal injury caused by unintentional activation of the system. For removal of Spiral Cable and Air Bag Module, see the SR section.
- Do not use electrical test equipment on any circuit related to the SRS unless instructed to in this Service Manual. SRS wiring harnesses can be identified by yellow and/or orange harnesses or harness connectors.

#### PRECAUTIONS WHEN USING POWER TOOLS (AIR OR ELECTRIC) AND HAMMERS

**WARNING:**

- When working near the Airbag Diagnosis Sensor Unit or other Airbag System sensors with the Ignition ON or engine running, DO NOT use air or electric power tools or strike near the sensor(s) with a hammer. Heavy vibration could activate the sensor(s) and deploy the air bag(s), possibly causing serious injury.
- When using air or electric power tools or hammers, always switch the Ignition OFF, disconnect the battery and wait at least three minutes before performing any service.

#### Precaution

INFOID:000000009484510

When installing rubber parts, final tightening must be carried out under unladen condition\* with tires on ground.

\* Fuel, radiator coolant and engine oil full. Spare tire, jack, hand tools and mats in designated positions.



# PREPARATION

< PREPARATION >

[M226]

## PREPARATION

### PREPARATION

#### Special Service Tool

INFOID:000000009484511

The actual shape of the tools may differ from those illustrated here.

Tool number (TechMate No.) Tool name	Description
205-D002 ( — ) Bearing splitter	Removing axle shaft bearing

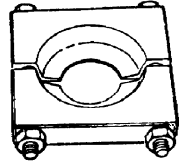

ZZA0700D

#### Commercial Service Tool

INFOID:000000009484512

Tool name	Description
1. Flare nut crowfoot 2. Torque wrench	Removing and installing each brake piping <b>a: 10 mm (0.39 in)</b>
Power tool	Loosening nuts, screws and bolts

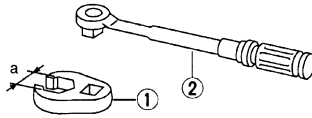

S-NT360



PIIB1407E

A  
B  
C  
RAX  
E  
F  
G  
H  
I  
J  
K  
L  
M  
N  
O  
P

# NOISE, VIBRATION AND HARSHNESS (NVH) TROUBLESHOOTING

< SYMPTOM DIAGNOSIS >

[M226]

## SYMPTOM DIAGNOSIS

### NOISE, VIBRATION AND HARSHNESS (NVH) TROUBLESHOOTING

#### NVH Troubleshooting Chart

INFOID:000000009484513

Use the chart below to help you find the cause of the symptom. If necessary, repair or replace these parts.

Reference page		<a href="#">RAX-20</a>	<a href="#">RAX-20</a>	<a href="#">RAX-20</a>	<a href="#">DLN-138, "NVH Troubleshooting Chart"</a>	<a href="#">DLN-224, "NVH Troubleshooting Chart"</a>	<a href="#">DLN-224, "NVH Troubleshooting Chart"</a>	<a href="#">RSU-4, "NVH Troubleshooting Chart"</a>	<a href="#">WT-44, "NVH Troubleshooting Chart"</a>	<a href="#">WT-44, "NVH Troubleshooting Chart"</a>	<a href="#">BR-5, "NVH Troubleshooting Chart"</a>
Possible cause and SUSPECTED PARTS		Improper installation, looseness	Parts interference	Wheel bearing damage	PROPELLER SHAFT	REAR FINAL DRIVE	SUSPENSION	TIRES	ROAD WHEEL	BRAKES	
Symptom	Noise	x	x		x	x	x	x	x	x	
	Shake	x	x		x		x	x	x	x	
	Vibration	x	x		x		x	x			
	Shimmy	x	x				x	x	x	x	
	Shudder	x					x	x	x	x	
	Poor quality ride or handling	x	x	x			x	x	x		

x: Applicable

## REMOVAL AND INSTALLATION

### ON-VEHICLE SERVICE

#### Rear Axle Parts

INFOID:000000009484514

- Check the axle parts for excessive play, wear, and damage. Replace as necessary.
- Shake each rear wheel to check for excessive play. Repair as necessary
- Retighten all nuts and bolts to the specified torque. Refer to [RAX-20](#).

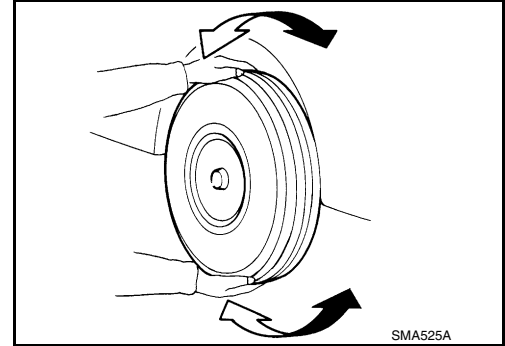

#### Rear Axle Bearing

INFOID:000000009484515

- Check that the axle shaft bearing operates smoothly. Replace as necessary.
- Check for excessive axial end play.

A  
B  
C  
RAX  
E  
F  
G  
H  
I  
J  
K  
L  
M  
N  
O  
P

# AXLE SHAFT

< UNIT REMOVAL AND INSTALLATION >

[M226]

## UNIT REMOVAL AND INSTALLATION

### AXLE SHAFT

#### Removal and Installation

INFOID:000000009484516

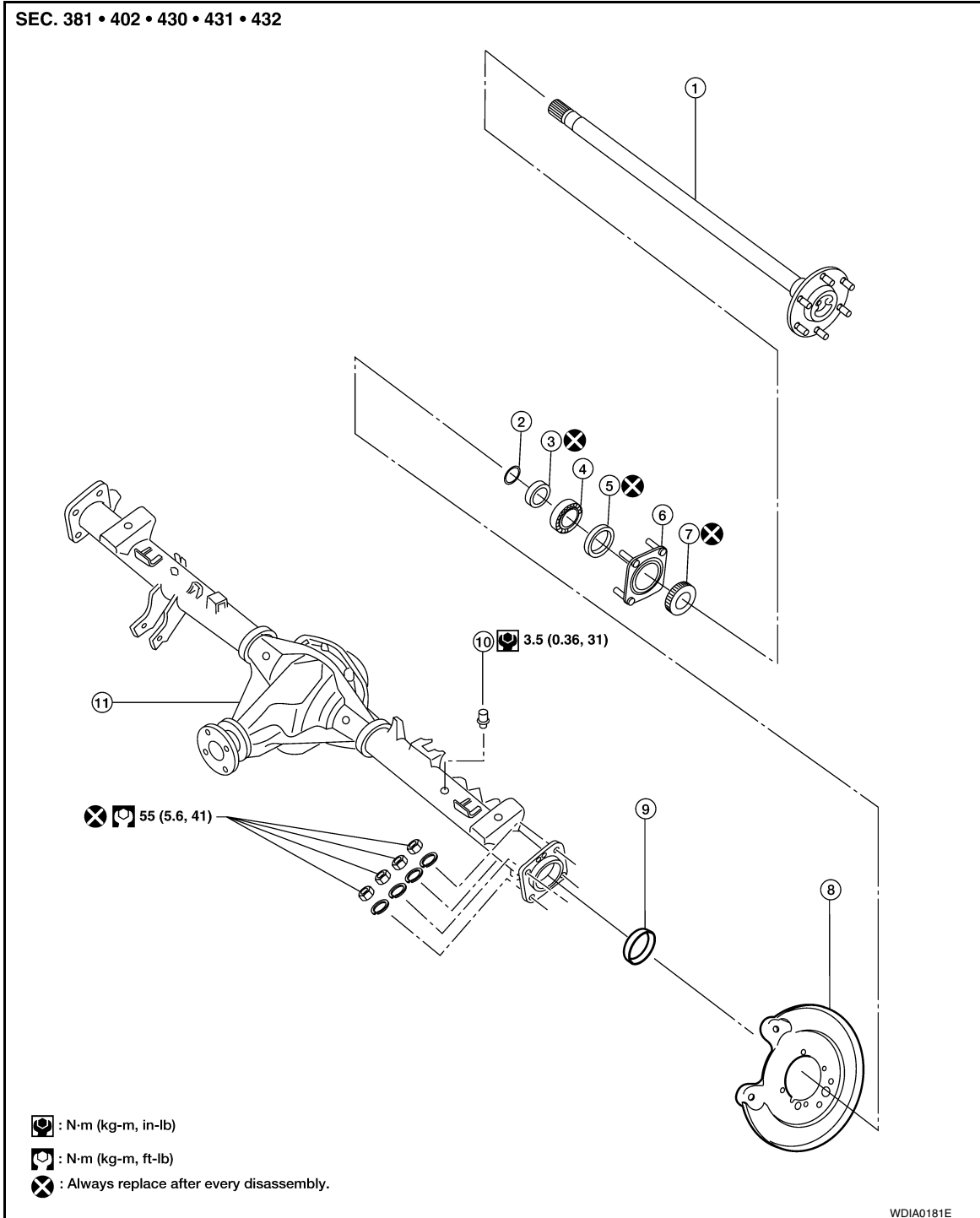

- |                       |                                 |                            |
|-----------------------|---------------------------------|----------------------------|
| 1. Axle shaft         | 2. Snap ring                    | 3. Bearing ring retainer   |
| 4. Axle shaft bearing | 5. Axle oil seal                | 6. Axle shaft bearing cage |
| 7. Wheel sensor rotor | 8. Back plate and torque member | 9. Axle shaft bearing cup  |
| 10. Breather          | 11. Rear final drive            |                            |

**CAUTION:**

Revision: October 2013

**RAX-20**

2014 Xterra NAM

# AXLE SHAFT

< UNIT REMOVAL AND INSTALLATION >

[M226]

Before removing the axle shaft, remove the wheel sensor to reposition the wheel sensor out of the way. Failure to do so may result in damage to the wheel sensor and cause the wheel sensor to become inoperative.

## REMOVAL

1. Remove the wheel and tire from the vehicle using power tool. Refer to [WT-48, "Adjustment"](#).
2. Remove the wheel sensor and position out of the way. Refer to [BRC-111, "Removal and Installation"](#) (TYPE 1), [BRC-232, "Removal and Installation"](#) (TYPE 2).
3. Without disassembling the hydraulic lines, remove the brake caliper using power tool. Position it aside with wire. Refer to [BR-39, "Removal and Installation of Brake Caliper and Disc Rotor"](#).
4. Put alignment marks on the disc rotor and wheel hub and bearing assembly, then remove the rotor.
5. Remove the parking brake assembly from the back plate and torque member. Refer to [PB-7, "Removal and Installation"](#).
6. Remove the four axle shaft bearing cage nuts and lock washers.

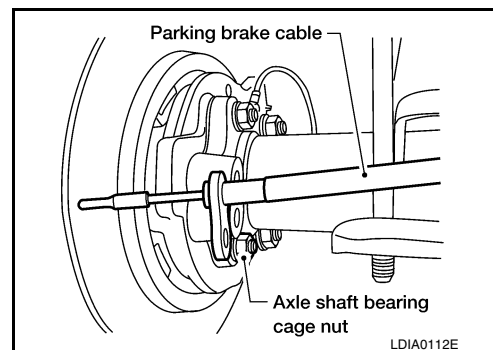

7. Remove the axle shaft assembly using a suitable tool.

### CAUTION:

- The axle shaft bearing cup may stay in place in the axle shaft housing. Remove the cup carefully so as not to damage the inner surface of the axle shaft housing.
- Do not reuse the axle oil seal.

8. Remove the back plate and torque member.
9. Remove the snap ring from the axle shaft using suitable snap ring pliers.

10. Secure the axle shaft in a suitable vise, then use a 1/4 in size drill bit to drill a hole approximately 3/4 into the thickness of the bearing ring retainer [3/4 thickness is approximately 6.3 mm (0.25 in) deep].

### CAUTION:

- Mount the axle shaft using a soft jaw vise to avoid damaging the axle shaft.
- Do not drill all the way through the bearing ring retainer, the drill may damage the axle shaft surface.

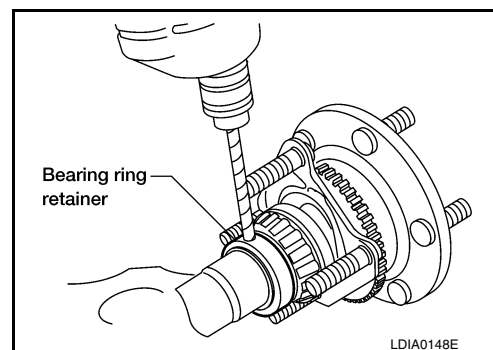

11. Strike the bearing ring retainer using a suitable chisel and hammer, with the chisel positioned across the drilled hole. Break the bearing ring retainer to remove it.

### CAUTION:

- Do not heat or cut the axle shaft bearing or bearing ring retainer with a torch during removal, doing so will damage the axle shaft.

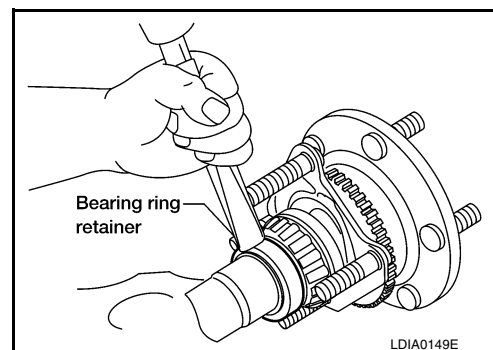

12. Remove the axle shaft bearing cage studs using a suitable hammer or press.
13. Pull the axle shaft bearing off of the axle shaft using Tool and a suitable press.

# AXLE SHAFT

< UNIT REMOVAL AND INSTALLATION >

[M226]

**Tool number** : 205-D002 ( — )

**CAUTION:**

- Do not tighten the Tool against the axle shaft.
- Do not heat or cut the axle shaft bearing or bearing ring retainer with a torch during removal, doing so will damage the axle shaft.

14. Remove the axle oil seal and discard.

**CAUTION:**

**Do not reuse the axle oil seal.**

15. Remove the wheel bearing cage.

**NOTE:**

- If reinstalling the old axle shaft, it may not be necessary to remove the wheel sensor rotor. Inspect the wheel sensor rotor and replace as necessary. Refer to [BRC-112, "Removal and Installation"](#) (TYPE 1), [BRC-233, "Removal and Installation"](#) (TYPE 2).
- The wheel sensor rotor cannot be reused after it is removed. If replacing the axle shaft, install a new wheel sensor rotor on to the new axle shaft. Refer to [BRC-112, "Removal and Installation"](#) (TYPE 1), [BRC-233, "Removal and Installation"](#) (TYPE 2).

## INSPECTION AFTER REMOVAL

### Axle Shaft

- Clean and remove all nicks and burrs.
- Check for straightness and distortion. Replace if necessary.
- Inspect machined surfaces for evidence of overheating, damage and wear. Replace if necessary.
- Measure the bearing ring retainer axle journal diameter. Replace if necessary.

**Bearing ring retainer axle journal diameter (minimum)** : Refer to [RAX-26, "Axle Bearing"](#).

### Axle Shaft Bearing and Cup

- Check that the axle shaft bearing and cup roll freely and are free from noise, cracks, pitting and wear. Replace if necessary.

### Axle Shaft Bearing Cage

- Check for deformation and cracks. Replace if necessary.

### Axle Shaft Housing

- Check the exterior and inner machined surfaces for deformation and cracks. Replace if necessary.

## INSTALLATION

1. If installing a new axle shaft, install a new wheel sensor rotor onto the new axle shaft. Refer to [BRC-112, "Removal and Installation"](#) (TYPE 1), [BRC-233, "Removal and Installation"](#) (TYPE 2).

**CAUTION:**

**Do not reuse wheel sensor rotor.**

2. Install the studs in the axle shaft bearing cage using a suitable hammer or press.
3. Install the axle shaft bearing cage.
4. Install a new axle oil seal.

**CAUTION:**

**Do not reuse the axle oil seal.**

5. Install the axle shaft bearing and cup on the axle shaft.

- Prepare an installer tool from a steel tube measuring 762 mm (30 in) long with an outside diameter of 53.98 mm (2.125 in) and an inside diameter of 41.28 mm (1.625 in).
- Press the axle shaft bearing and cup onto the axle shaft using a suitable press and the installer tool, until a 0.038 mm (0.0015 in) feeler gauge does not fit in between the axle shaft bearing cup and seat.

**CAUTION:**

**Make sure the axle shaft bearing and cup, axle oil seal, and axle shaft bearing cage are installed facing in the correct direction.**

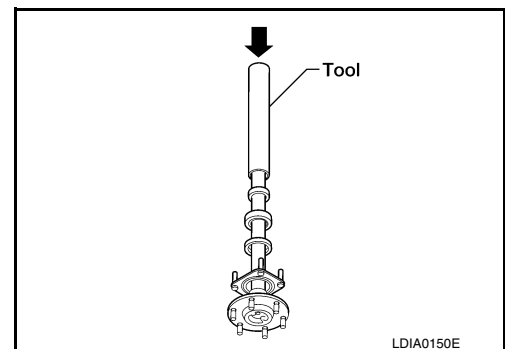

## AXLE SHAFT

< UNIT REMOVAL AND INSTALLATION >

[M226]

6. Install the bearing ring retainer onto the axle shaft.
  - Press the bearing ring retainer onto the axle shaft with a minimum force of 31,100 N (3172 kg, 6992 lb) until a 0.038 mm (.0015 in) feeler gauge does not fit between the bearing inner race and the bearing ring retainer in at least one point.
7. Install the snap ring so it is fully seated into the groove on the axle shaft, using suitable snap ring pliers.
8. Install the back plate and torque member.
9. Install the axle shaft assembly into the axle shaft housing.
10. Install the axle shaft bearing cage lock washers and nuts. Tighten the axle shaft bearing cage nuts to specification.

**CAUTION:**

**Do not reuse axle shaft bearing cage nuts.**

11. Install the parking brake assembly onto the back plate and torque member. Refer to [PB-7, "Removal and Installation"](#).
12. Install the rear brake rotor. Refer to [BR-39, "Removal and Installation of Brake Caliper and Disc Rotor"](#).
13. Install the wheel sensor. Refer to [BRC-111, "Removal and Installation"](#) (TYPE 1), [BRC-232, "Removal and Installation"](#) (TYPE 2).
14. Install the wheel and tire. Refer to [WT-48, "Adjustment"](#).

A  
B  
C  
RAX  
E  
F  
G  
H  
I  
J  
K  
L  
M  
N  
O  
P

## AXLE BEARING

< UNIT REMOVAL AND INSTALLATION >

[M226]

### AXLE BEARING

---

#### Removal and Installation

INFOID:000000009484517

The axle bearing must be replaced every time the axle shaft is removed and installed. Refer to [RAX-20](#), "[Removal and Installation](#)".

**CAUTION:**

**Do not reuse the axle bearing.**



# AXLE OIL SEAL

< UNIT REMOVAL AND INSTALLATION >

[M226]

## AXLE OIL SEAL

### Removal and Installation

INFOID:000000009484518

The axle oil seal must be replaced every time the axle shaft is removed and installed. Refer to [RAX-20](#), "[Removal and Installation](#)".

**CAUTION:**

**Do not reuse the axle oil seal.**

A  
B  
C  
E  
F  
G  
H  
I  
J  
K  
L  
M  
N  
O  
P

RAX

## SERVICE DATA AND SPECIFICATIONS (SDS)

< SERVICE DATA AND SPECIFICATIONS (SDS)

[M226]

## SERVICE DATA AND SPECIFICATIONS (SDS)

SERVICE DATA AND SPECIFICATIONS (SDS)

Axle Bearing

INFOID:000000009484519

Bearing ring retainer axle journal diameter (minimum)	39.726 mm (1.5640 in) minimum
---	-------------------------------