

SECTION **SB**
SEAT BELT

A
B
C
D
E
F
G
SB
I
J
K
L
M
N
O
P

CONTENTS

BASIC INSPECTION	2	REMOVAL AND INSTALLATION	6
COMPONENT INSPECTION	2	SEAT BELTS	6
Inspection	2	Removal and Installation of Front Seat Belt	6
PRECAUTION	5	Removal and Installation of Rear Seat Belt	8
PRECAUTIONS	5	LATCH (LOWER ANCHORS AND TETHER FOR CHILDREN) SYSTEM	11
Precaution for Supplemental Restraint System (SRS) "AIR BAG" and "SEAT BELT PRE-TENSIONER"	5	Removal and Installation	11
Precaution for Seat Belt Service	5	TOP TETHER STRAP CHILD RESTRAINT	12
		Removal and Installation	12

COMPONENT INSPECTION

< BASIC INSPECTION >

BASIC INSPECTION

COMPONENT INSPECTION

Inspection

INFOID:000000009485354

AFTER A COLLISION

WARNING:

Inspect all seat belt assemblies including retractors and attaching hardware after any collision. NISSAN/INFINITI recommends that all seat belt assemblies in use during a collision be replaced unless the collision was minor and the belts show no damage and continue to operate properly. Failure to do so could result in serious personal injury in an accident. Seat belt assemblies not in use during a collision should also be replaced if either damage or improper operation is noted. Seat belt pretensioners should be replaced even if the seat belts are not in use during a frontal collision in which the air bags are deployed.

Replace any seat belt assembly (including anchor bolts) if:

- The seat belt was in use at the time of a collision (except for minor collisions and the belts, retractors and buckles show no damage and continue to operate properly).
- The seat belt was damaged in an accident (i.e. torn webbing, bent retractor or guide, etc.).
- The seat belt attaching point is damaged in an accident. Inspect the seat belt attaching area for damage or distortion and repair if necessary before installing a new seat belt assembly.
- Anchor bolts are deformed or worn out.
- The seat belt pre-tensioner should be replaced even if the seat belts are not in use during the collision in which the air bags are deployed.

PRELIMINARY CHECKS

1. Check the seat belt warning lamp for proper operation per the following:
 - a. Turn ignition switch ON. The seat belt warning lamp should illuminate.
 - b. Fasten driver seat belt. The seat belt warning lamp should turn OFF.
 2. If the air bag warning lamp is blinking, perform self-diagnosis with CONSULT and air bag warning lamp. Refer to [SRC-15. "Trouble Diagnosis without CONSULT"](#).
 3. Check that the seat belt retractor, seat belt anchor and buckle bolts are tightened firmly.
 4. Check the shoulder seat belt guide and shoulder belt height adjuster for front seats. Check that guide swivels freely and that webbing lays flat and does not bind in guide. Check that height adjuster operates properly and holds securely.
 5. Check retractor operation:
 - a. Fully extend the seat belt webbing and check for twists, tears or other damage.
 - b. Allow the seat belt to retract. Check that webbing returns smoothly and completely into the retractor. If the seat belt does not return smoothly, wipe the inside of the loops with a clean paper cloth. Dirt build-up in the loops of the upper anchors can cause the seat belts to retract slowly.
 - c. Fasten the seat belt. Check that seat belt returns smoothly and completely to the retractor. If the webbing does not return smoothly, the cause may be an accumulation of dust or dirt. Use the "SEAT BELT TAPE SET" and perform the following steps.
 - d. Inspect the front seat belt D-ring anchor
 1. Pull the seat belt out to a length of 500 mm (19.69 in) or more.
 2. Hold the seat belt at the center pillar webbing opening with a clip or other device.
 3. Pass a thin wire through the D-ring anchor webbing opening. Hold both ends of the wire and pull it tightly while moving it up and down several times along the webbing opening surface to remove dirt stuck there.
 4. Any dirt that cannot be removed with the wire can be removed by cleaning the opening with a clean cloth.
 5. Apply tape at the point where the webbing contacts the D-ring anchor webbing opening.
- NOTE:**
Apply the tape so that there is no slack or wrinkling.
6. Remove the clip holding the seat belt and check that the webbing returns smoothly.
 6. Repeat steps above if necessary to check the other seat belts.

COMPONENT INSPECTION

< BASIC INSPECTION >

SEAT BELT RETRACTOR ON-VEHICLE CHECK

Emergency Locking Retractors (ELR) and Automatic Locking Retractors (ALR)

NOTE:

All seat belt retractors are Emergency Locking Retractors (ELR) type. In an emergency (sudden stop) the retractor will lock and prevent the webbing from extending any further. All 3-point type seat belt retractors except the driver seat belt also have an Automatic Locking Retractors (ALR) mode. The ALR mode (also called child restraint mode) is used when installing child seats. The ALR mode is activated when the seat belt is fully extended. When the webbing is then retracted partially, the ALR mode automatically locks the seat belt in a specific position so the webbing cannot be extended any further. To cancel the ALR mode, allow the seat belt to fully wind back into the retractor.

Check the seat belt retractors with the following test(s) to determine if a retractor assembly is operating properly.

ELR Function Stationary Check

Grasp the shoulder webbing and pull forward quickly. The retractor should lock and prevent the belt from extending further.

ALR Function Stationary Check

1. Pull out the entire length of seat belt from retractor until a click is heard.
2. Retract the webbing partially. A clicking noise should be heard as the webbing retracts, indicating that the retractor is in the Automatic Locking Retractors (ALR) mode.
3. Grasp the seat belt and try to pull out the retractor. The webbing must lock and not extend any further. If it does not operate normally, replace the retractor assembly.
4. Allow the entire length of the webbing to retract to cancel the automatic locking mode.

ELR Function Moving Check

WARNING:

Perform the following test in a safe, open area clear of other vehicles and obstructions (for example, a large, empty parking lot). Road surface must be paved and dry. Do not perform the following test on wet or gravel roads or on public streets and highways. This could result in an accident and serious personal injury. The driver and passenger must be prepared to brace themselves in the event that the retractor does not lock.

1. Fasten driver seat belt. Buckle a passenger into the seat for the belt that is to be tested.
2. Proceed to the designated safe area.
3. Drive the vehicle at approximately 16 km/h (10 MPH). Notify any passengers of a pending sudden stop and the driver and passenger must be prepared to brace themselves in the event that the retractor does not lock. Apply brakes firmly and make a very hard stop.

During stopping, seat belts should lock and not be extended. If the seat belt retractor assembly does not lock, perform the retractor off-vehicle check.

FRONT SEAT BELT RETRACTOR OFF-VEHICLE CHECK

1. Remove the front seat belt retractor. Refer to [SB-6, "Removal and Installation of Front Seat Belt"](#).
2. Slowly pull out webbing while tilting the seat belt retractor forward from the mounted position without twisting the seat belt retractor as shown.

A : The webbing can be pulled out if the retractor is tilted 15° degree or less.

B : The webbing can not be pulled out if the retractor is tilted 35° degrees or more.

NOTE:

A and B show tilting angles.

⇐: Front

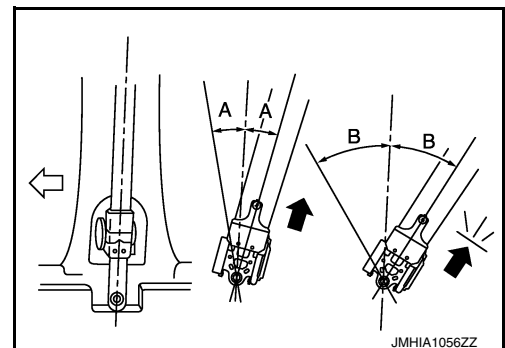

3. Replace the seat belt retractor if it does not operate within specifications.

REAR SEAT BELT RETRACTOR OFF-VEHICLE CHECK

COMPONENT INSPECTION

< BASIC INSPECTION >

1. Remove the rear seat belt retractor. Refer to [SB-8, "Removal and Installation of Rear Seat Belt"](#).
2. Slowly pull out webbing while tilting the seat belt retractor forward from the mounted position without twisting the seat belt retractor as shown.

A : The webbing can be pulled out if the retractor is tilted 15° degree or less.

B : The webbing can not be pulled out if the retractor is tilted 35° degrees or more.

NOTE:

A and B show tilting angles.

⇐: Front

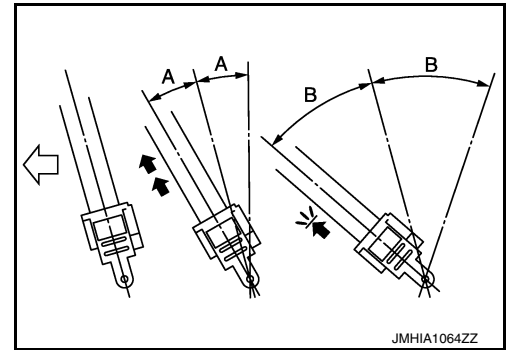

3. Replace the seat belt retractor if it does not operate within specifications.

REAR SEAT BELT CENTER RETRACTOR OFF-VEHICLE CHECK

1. Remove the rear seat belt center retractor. Refer to [SB-8, "Removal and Installation of Rear Seat Belt"](#).
2. Slowly pull out webbing while tilting the seat belt retractor forward from the mounted position without twisting the seat belt retractor as shown.

A : The webbing can be pulled out if the retractor is tilted 15° degree or less.

B : The webbing can not be pulled out if the retractor is tilted 35° degrees or more.

NOTE:

A and B show tilting angles.

⇐: Front

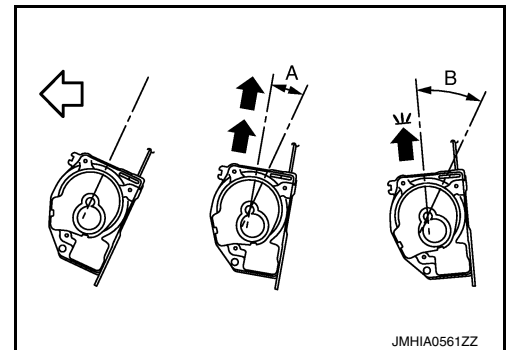

3. Replace the seat belt retractor if it does not operate within specifications.

PRECAUTIONS

< PRECAUTION >

PRECAUTION

PRECAUTIONS

Precaution for Supplemental Restraint System (SRS) "AIR BAG" and "SEAT BELT PRE-TENSIONER"

INFOID:000000010219714

The Supplemental Restraint System such as "AIR BAG" and "SEAT BELT PRE-TENSIONER", used along with a front seat belt, helps to reduce the risk or severity of injury to the driver and front passenger for certain types of collision. This system includes seat belt switch inputs and dual stage front air bag modules. The SRS system uses the seat belt switches to determine the front air bag deployment, and may only deploy one front air bag, depending on the severity of a collision and whether the front occupants are belted or unbelted. Information necessary to service the system safely is included in the SR and SB section of this Service Manual.

WARNING:

- To avoid rendering the SRS inoperative, which could increase the risk of personal injury or death in the event of a collision which would result in air bag inflation, all maintenance must be performed by an authorized NISSAN/INFINITI dealer.
- Improper maintenance, including incorrect removal and installation of the SRS, can lead to personal injury caused by unintentional activation of the system. For removal of Spiral Cable and Air Bag Module, see the SR section.
- Do not use electrical test equipment on any circuit related to the SRS unless instructed to in this Service Manual. SRS wiring harnesses can be identified by yellow and/or orange harnesses or harness connectors.

PRECAUTIONS WHEN USING POWER TOOLS (AIR OR ELECTRIC) AND HAMMERS

WARNING:

- When working near the Airbag Diagnosis Sensor Unit or other Airbag System sensors with the Ignition ON or engine running, DO NOT use air or electric power tools or strike near the sensor(s) with a hammer. Heavy vibration could activate the sensor(s) and deploy the air bag(s), possibly causing serious injury.
- When using air or electric power tools or hammers, always switch the Ignition OFF, disconnect the battery and wait at least three minutes before performing any service.

Precaution for Seat Belt Service

INFOID:000000009485356

CAUTION:

- Before removing the seat belt pre-tensioner assembly, turn the ignition switch OFF, disconnect both battery terminals and wait at least three minutes.
- After replacing or reinstalling seat belt pre-tensioner assembly, or reconnecting seat belt pre-tensioner assembly connector, ensure entire SRS operates properly. Refer to [SRC-13, "SRS Operation Check"](#).
- Do not disassemble buckle or seat belt assembly.
- Do not reuse seat belt anchor bolts after removal. Replace with new ones.
- Replace anchor bolts if they are deformed or worn out.
- Do not oil tongue and buckle.
- If any component of seat belt assembly is questionable, do not repair. Replace the whole seat belt assembly.
- If webbing is cut, frayed, or damaged, replace seat belt assembly.
- When replacing seat belt assembly, use a genuine NISSAN seat belt assembly.

SEAT BELTS

< REMOVAL AND INSTALLATION >

REMOVAL AND INSTALLATION

SEAT BELTS

Removal and Installation of Front Seat Belt

INFOID:000000009485357

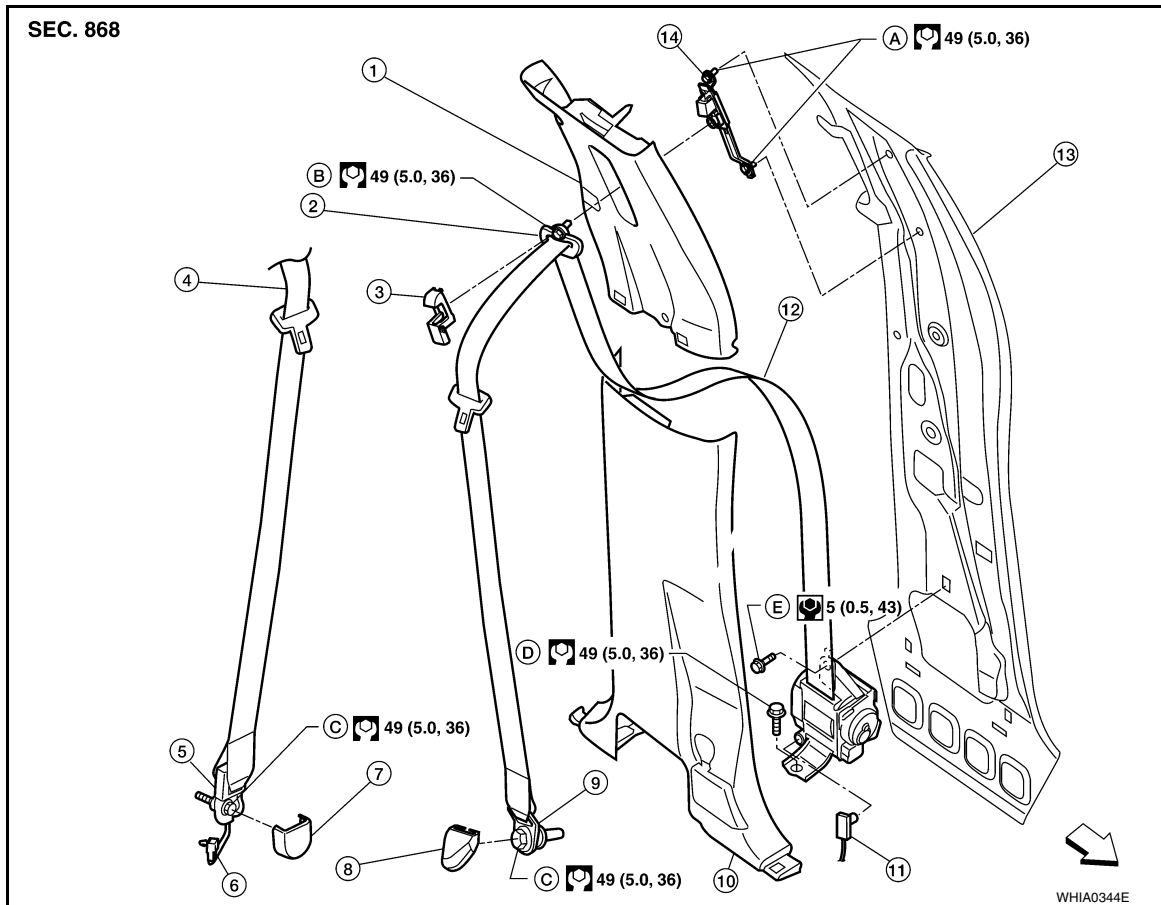

- | | | |
|---|---|--|
| 1. Center pillar upper finisher | 2. D-ring anchor | 3. D-ring anchor bolt cover |
| 4. Seat belt retractor and belt assembly (RH) | 5. Seat belt lower anchor (RH) (seat belt tension sensor) | 6. Seat belt tension sensor connector |
| 7. Anchor cover (RH) | 8. Anchor cover (LH) | 9. Seat belt lower anchor (LH) |
| 10. Center pillar lower finisher | 11. Seat belt pre-tensioner connector | 12. Seat belt retractor and belt assembly (LH) |
| 13. Center pillar | 14. Seat belt height adjuster | A. Height adjuster anchor bolt |
| B. D-ring anchor bolt | C. Seat belt lower anchor bolt | D. Retractor anchor bolt |
| E. Retractor bolt upper | ↔ Front | |

REMOVAL OF SEAT BELT RETRACTOR

CAUTION:

• Before servicing SRS, turn the ignition switch off, disconnect both battery terminals and wait at least three minutes.

1. Disconnect the negative and positive battery terminals, then wait at least three minutes. Refer to [PG-72, "Removal and Installation"](#).
2. Remove the center pillar upper/lower finishers. Refer to [INT-18, "Removal and Installation"](#).
3. Remove anchor cover and seat belt lower anchor bolt.
4. Remove the retractor anchor bolt, retractor bolt upper and the retractor and belt assembly.
 - On RH side, disconnect the seat belt tension sensor.

SEAT BELTS

< REMOVAL AND INSTALLATION >

5. Disconnect the harness connector from the seat belt pre-tensioner.

CAUTION:

- For installing/removing seat belt pre-tensioner connector, insert a thin screwdriver wrapped in tape into the notch, lift the lock and remove the connector.
- Install the connector with the lock raised, and push the lock into the connector.

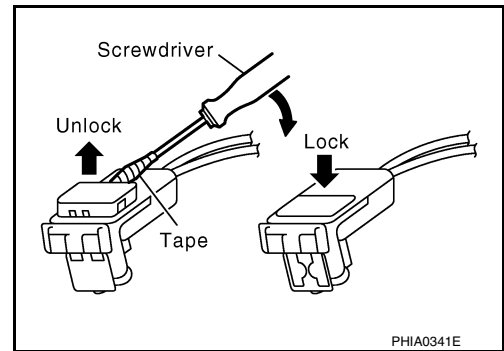

INSTALLATION OF SEAT BELT RETRACTOR

Installation is in the reverse order of removal.

CAUTION:

Hold seat belt tension sensor harness away from being caught or twisted during installation.

- Install the seat belt retractor upper bolt first.
- Ensure that seat belt height adjuster is locked in the lowest position during installation.

REMOVAL OF SEAT BELT BUCKLE

1. Remove the front seat. Refer to [SE-21, "Removal and Installation"](#).
2. Remove screw and seat cushion inner finisher.
3. Remove the anchor bolt and buckle.
4. Disconnect the buckle switch connector from the seat connector.

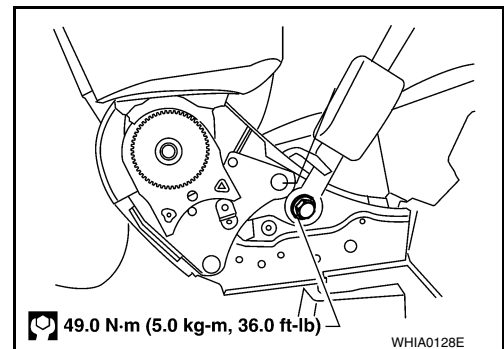

INSTALLATION OF SEAT BELT BUCKLE

Installation is in the reverse order of removal.

A
B
C
D
E
F
G
SB
I
J
K
L
M
N
O
P

SEAT BELTS

< REMOVAL AND INSTALLATION >

Removal and Installation of Rear Seat Belt

INFOID:00000009485358

Outboard Seat

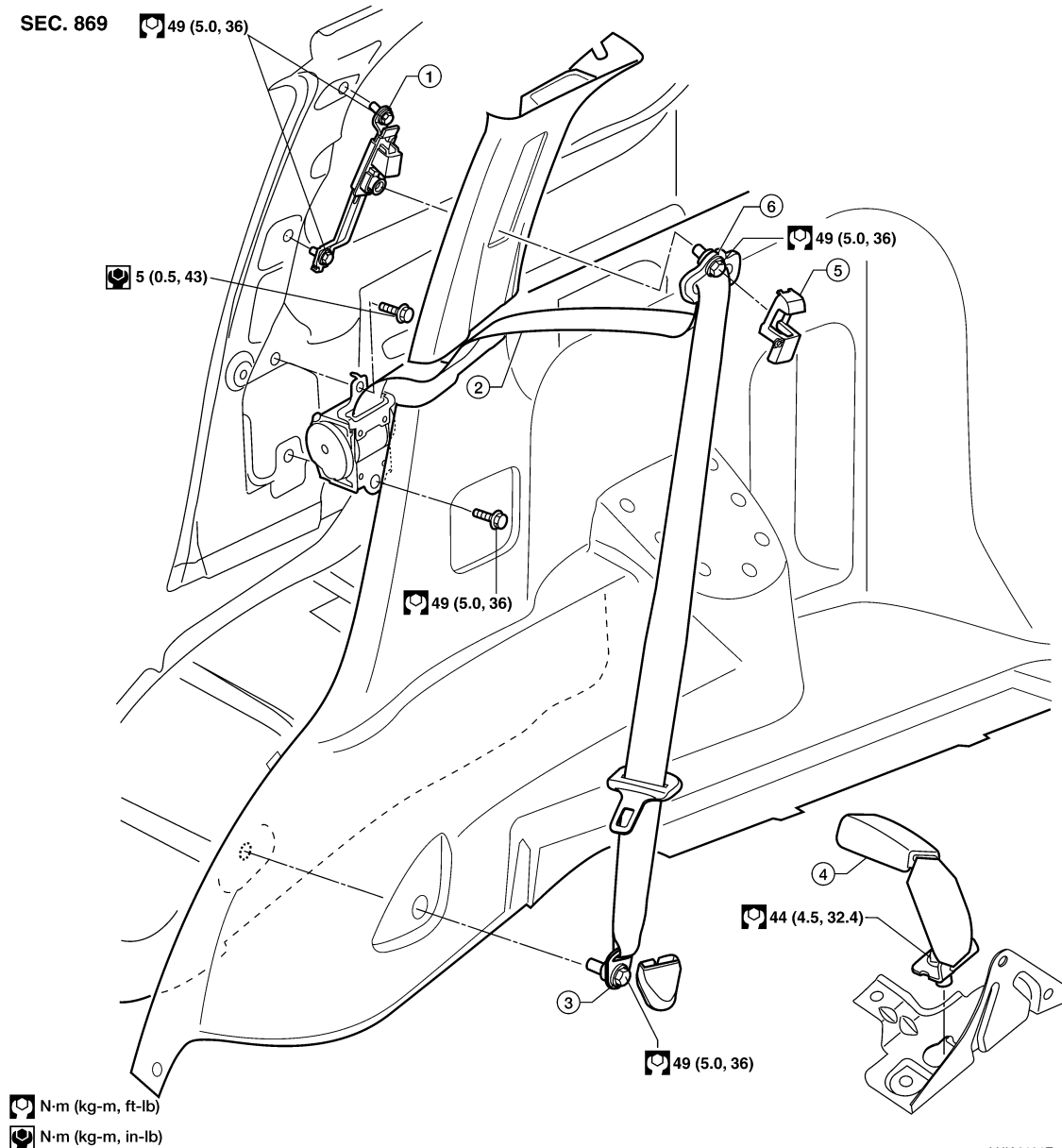

LHIA0101E

- | | | |
|------------------------------|--|---------------------------|
| 1. Seat belt height adjuster | 2. Seat belt retractor and belt assembly | 3. Seat belt lower anchor |
| 4. Seat belt buckle | 5. D-ring anchor bolt cover | 6. D-ring anchor |

SEAT BELTS

< REMOVAL AND INSTALLATION >

Center Seat

SEC. 869

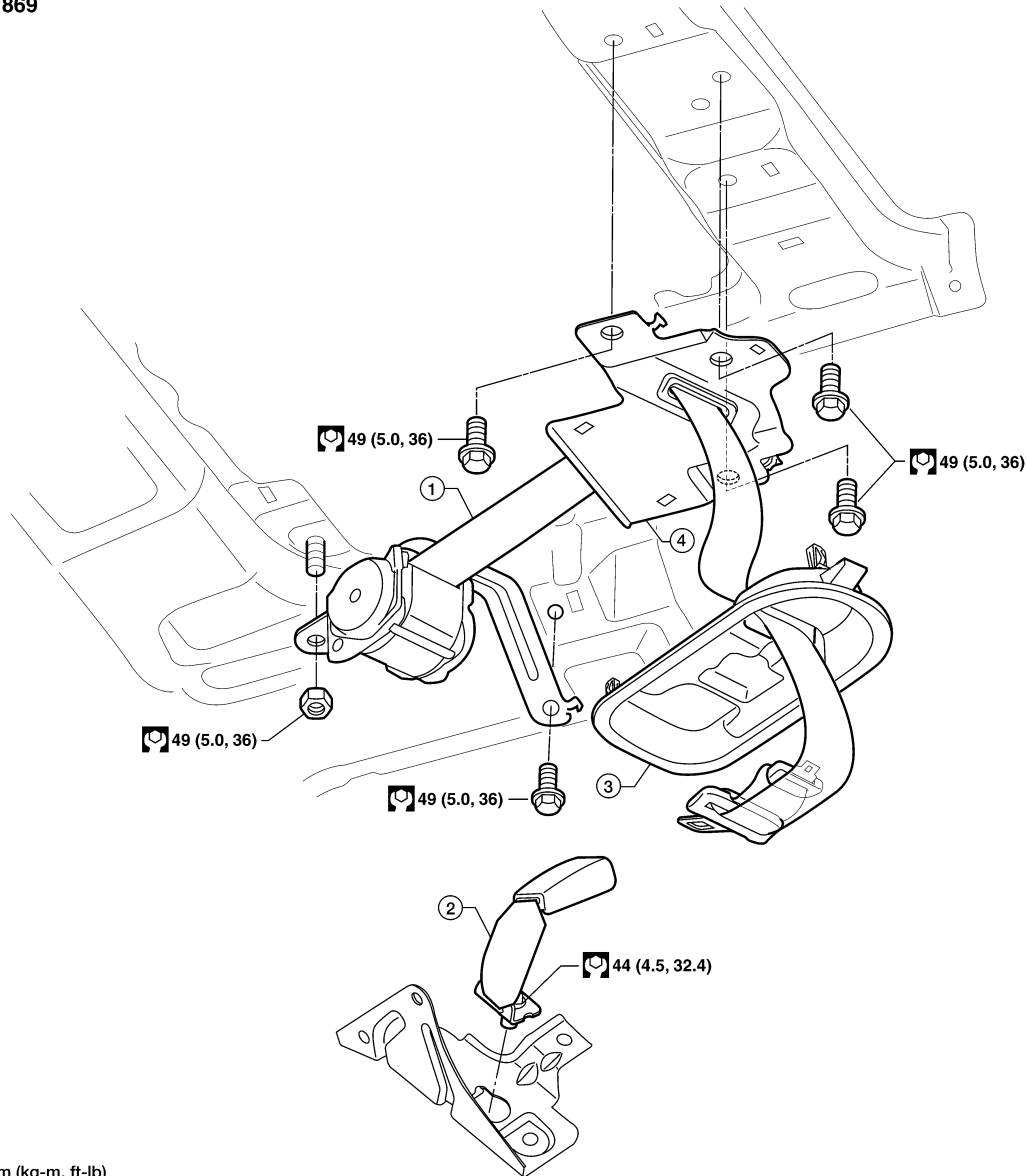

N-m (kg-m, ft-lb)

LHIA0102E

1. Seat belt retractor and belt assembly 2. Seat belt buckle 3. Finisher
4. Guide plate

REMOVAL OF SEAT BELT RETRACTOR - OUTBOARD

1. Remove seat belt lower anchor cover and bolt.
2. Remove the D-ring anchor bolt cover and D-ring anchor bolt.
3. Remove the upper and lower luggage area trim. Refer to [INT-18, "Removal and Installation"](#).
4. Remove anchor cover and seat belt lower anchor bolt
5. Remove seat belt retractor anchor bolt and the seat belt assembly.

INSTALLATION OF SEAT BELT RETRACTOR - OUTBOARD

- Installation is in the reverse order of removal.
- Ensure that seat belt height adjuster is locked in the lowest position during installation.

REMOVAL OF SEAT BELT RETRACTOR - CENTER

1. Remove headlining. Refer to [INT-21, "Removal and Installation"](#).

A
B
C
D
E
F
G
SB
I
J
K
L
M
N
O
P

SEAT BELTS

< REMOVAL AND INSTALLATION >

2. Remove seat belt guide plate bolts.
3. Remove seat belt retractor and belt assembly bolt and nut, then remove from vehicle.

INSTALLATION OF SEAT BELT RETRACTOR - CENTER

Installation is in the reverse order of removal.

REMOVAL OF SEAT BELT BUCKLE

1. Remove the rear seat cushion. Refer to [SE-26. "Removal and Installation"](#).
2. Remove the anchor bolt and buckle.

INSTALLATION OF SEAT BELT BUCKLE

Installation is in the reverse order of removal.

LATCH (LOWER ANCHORS AND TETHER FOR CHILDREN) SYSTEM

< REMOVAL AND INSTALLATION >

LATCH (LOWER ANCHORS AND TETHER FOR CHILDREN) SYSTEM

Removal and Installation

INFOID:000000009485359

NOTE:

The LATCH (Lower Anchors and Tether for Children) system is not serviceable.

- A
- B
- C
- D
- E
- F
- G
- SB
- I
- J
- K
- L
- M
- N
- O
- P

TOP TETHER STRAP CHILD RESTRAINT

< REMOVAL AND INSTALLATION >

TOP TETHER STRAP CHILD RESTRAINT

Removal and Installation

INFOID:000000009485360

NOTE:

The Top Tether Strap Child Restraint system is not serviceable.