

SECTION VTL
VENTILATION SYSTEM

A
B
C
D
E
F
G
H
VTL
J
K
L
M
N
O
P

CONTENTS

PRECAUTION	2	Removal and Installation	9
PRECAUTIONS	2	VARIABLE BLOWER CONTROL	10
Precaution for Supplemental Restraint System (SRS) "AIR BAG" and "SEAT BELT PRE-TENSIONER"	2	Removal and Installation	10
Precaution for Working with HFC-134a (R-134a).....	2	FRONT BLOWER MOTOR RESISTOR	11
Precaution for Work	3	Removal and Installation	11
PREPARATION	4	HEATER & COOLING UNIT ASSEMBLY	12
PREPARATION	4	Component	12
Special Service Tool	4	Removal and Installation	12
Commercial Service Tool	4	EVAPORATOR	14
SYSTEM DESCRIPTION	5	Removal and Installation	14
IN-CABIN MICROFILTER	5	EXPANSION VALVE	16
Description	5	Removal and Installation	16
PERIODIC MAINTENANCE	6	HEATER CORE	17
IN-CABIN MICROFILTER	6	Component	17
Removal and Installation	6	Removal and Installation	17
REMOVAL AND INSTALLATION	7	INTAKE DOOR MOTOR	18
CONTROL UNIT	7	Removal and Installation	18
Removal and Installation	7	MODE DOOR MOTOR	19
INTAKE SENSOR	8	Removal and Installation	19
Removal and Installation	8	AIR MIX DOOR MOTOR	20
BLOWER MOTOR	9	Removal and Installation	20
Component	9	DUCTS AND GRILLES	21
		Component	21
		Removal and Installation	22

PRECAUTIONS

< PRECAUTION >

PRECAUTION

PRECAUTIONS

Precaution for Supplemental Restraint System (SRS) "AIR BAG" and "SEAT BELT PRE-TENSIONER"

INFOID:000000010226516

The Supplemental Restraint System such as "AIR BAG" and "SEAT BELT PRE-TENSIONER", used along with a front seat belt, helps to reduce the risk or severity of injury to the driver and front passenger for certain types of collision. This system includes seat belt switch inputs and dual stage front air bag modules. The SRS system uses the seat belt switches to determine the front air bag deployment, and may only deploy one front air bag, depending on the severity of a collision and whether the front occupants are belted or unbelted. Information necessary to service the system safely is included in the SR and SB section of this Service Manual.

WARNING:

- To avoid rendering the SRS inoperative, which could increase the risk of personal injury or death in the event of a collision which would result in air bag inflation, all maintenance must be performed by an authorized NISSAN/INFINITI dealer.
- Improper maintenance, including incorrect removal and installation of the SRS, can lead to personal injury caused by unintentional activation of the system. For removal of Spiral Cable and Air Bag Module, see the SR section.
- Do not use electrical test equipment on any circuit related to the SRS unless instructed to in this Service Manual. SRS wiring harnesses can be identified by yellow and/or orange harnesses or harness connectors.

PRECAUTIONS WHEN USING POWER TOOLS (AIR OR ELECTRIC) AND HAMMERS

WARNING:

- When working near the Airbag Diagnosis Sensor Unit or other Airbag System sensors with the Ignition ON or engine running, DO NOT use air or electric power tools or strike near the sensor(s) with a hammer. Heavy vibration could activate the sensor(s) and deploy the air bag(s), possibly causing serious injury.
- When using air or electric power tools or hammers, always switch the Ignition OFF, disconnect the battery and wait at least three minutes before performing any service.

Precaution for Working with HFC-134a (R-134a)

INFOID:000000009484323

WARNING:

- CFC-12 (R-12) refrigerant and HFC-134a (R-134a) refrigerant are not compatible. If the refrigerants are mixed compressor failure is likely to occur. Refer to [HA-3, "Contaminated Refrigerant"](#). To determine the purity of HFC-134a (R-134a) in the vehicle and recovery tank, use refrigerant recovery/recycling equipment and refrigerant identifier.
- Use only specified oil for the HFC-134a (R-134a) A/C system and HFC-134a (R-134a) components. If oil other than that specified is used, compressor failure is likely to occur.
- The specified HFC-134a (R-134a) oil rapidly absorbs moisture from the atmosphere. The following handling precautions must be observed:
 - When removing refrigerant components from a vehicle, immediately cap (seal) the component to minimize the entry of moisture from the atmosphere.
 - When installing refrigerant components to a vehicle, do not remove the caps (unseal) until just before connecting the components. Connect all refrigerant loop components as quickly as possible to minimize the entry of moisture into system.
 - Only use the specified oil from a sealed container. Immediately reseal containers of oil. Without proper sealing, oil will become moisture saturated and should not be used.
 - Avoid breathing A/C refrigerant and oil vapor or mist. Exposure may irritate eyes, nose and throat. Remove HFC-134a (R-134a) from the A/C system using certified service equipment meeting requirements of SAE J2210 [HFC-134a (R-134a) recycling equipment], or SAE J2209 [HFC-134a (R-134a) recovery equipment]. If accidental system discharge occurs, ventilate work area before resuming service. Additional health and safety information may be obtained from refrigerant and oil manufacturers.
- Do not allow the refrigerant oil to come in contact with styrofoam parts. Damage may result.

PRECAUTIONS

< PRECAUTION >

Precaution for Work

INFOID:000000009484324

- When removing or disassembling each component, be careful not to damage or deform it. If a component may be subject to interference, be sure to protect it with a shop cloth. A
- When removing (disengaging) components with a screwdriver or similar tool, be sure to wrap the component with a shop cloth or vinyl tape to protect it. B
- Protect the removed parts with a shop cloth and prevent them from being dropped.
- Replace a deformed or damaged clip. C
- If a part is specified as a non-reusable part, always replace it with a new one.
- Be sure to tighten bolts and nuts securely to the specified torque.
- After installation is complete, be sure to check that each part works properly.
- Follow the steps below to clean components: D
- Water soluble dirt: E
- Dip a soft cloth into lukewarm water, wring the water out of the cloth and wipe the dirty area.
- Then rub with a soft, dry cloth.
- Oily dirt: E
- Dip a soft cloth into lukewarm water with mild detergent (concentration: within 2 to 3%) and wipe the dirty area.
- Then dip a cloth into fresh water, wring the water out of the cloth and wipe the detergent off. F
- Then rub with a soft, dry cloth.
- Do not use organic solvent such as thinner, benzene, alcohol or gasoline.
- For genuine leather seats, use a genuine leather seat cleaner. G

A
B
C
D
E
F
G
H
J
K
L
M
N
O
P

VTL

PREPARATION

< PREPARATION >

PREPARATION

PREPARATION

Special Service Tool

INFOID:000000009484325

The actual shape of the tools may differ from those illustrated here.

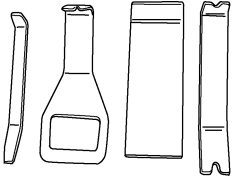
Tool number (TechMate No.) Tool name	Description
— (J-46534) Trim Tool Set  AWJIA0483ZZ	Removing trim components

Commercial Service Tool

INFOID:000000009484326

Tool name	Description
Power tool  PIIB1407E	Loosening nuts, screws and bolts

IN-CABIN MICROFILTER

< SYSTEM DESCRIPTION >

SYSTEM DESCRIPTION

IN-CABIN MICROFILTER

Description

INFOID:000000009484327

FUNCTION

The air inside the passenger compartment is filtered by the in-cabin microfilters when the heater or A/C controls are set on either the recirculation or fresh mode. The two in-cabin microfilters are located in the front heater and cooling unit assembly.

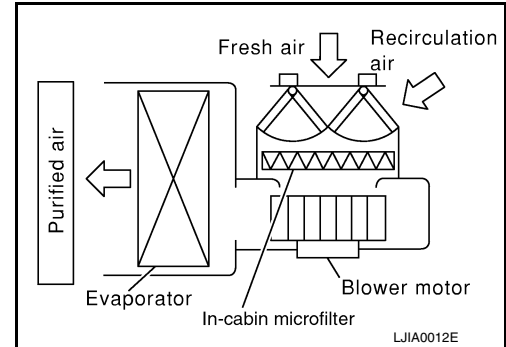

REPLACEMENT TIMING

Replacement of the two in-cabin microfilters is recommended on a regular interval depending on the driving conditions. Refer to XX-XX, *****!. It may also be necessary to replace the two in-cabin microfilters as part of a component replacement if the in-cabin microfilters are damaged.

A
B
C
D
E
F
G
H
J
K
L
M
N
O
P

VTL

IN-CABIN MICROFILTER

< PERIODIC MAINTENANCE >

PERIODIC MAINTENANCE

IN-CABIN MICROFILTER

Removal and Installation

INFOID:00000009484328

REPLACEMENT PROCEDURE

1. Open the lower glove box and press in on the sides so that it will open completely allowing it to hang by the cord.

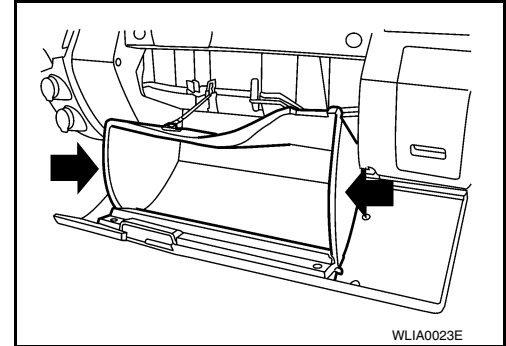

2. Gently lift up on the tab (1), then pull the in-cabin microfilter cover down (2) to remove the cover (3).

CAUTION:

Use care when depressing the tab to avoid damaging it.

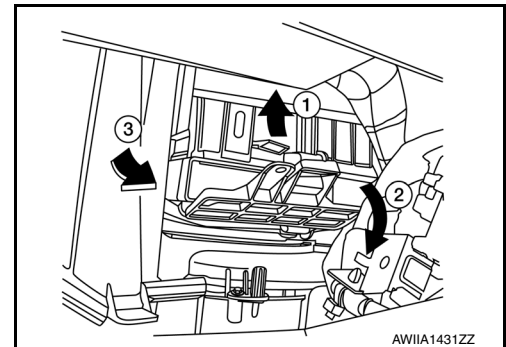

3. Remove the in-cabin microfilters from the front heater and cooling unit housing.

4. Insert the first new in-cabin microfilter into the front heater and cooling unit housing and slide it over to the right. Insert the second new in-cabin microfilter into the front heater and cooling unit housing.

NOTE:

The in-cabin microfilters are marked with air flow arrows. The end of the microfilter with the arrow should face the rear of the vehicle. The arrows should point downward.

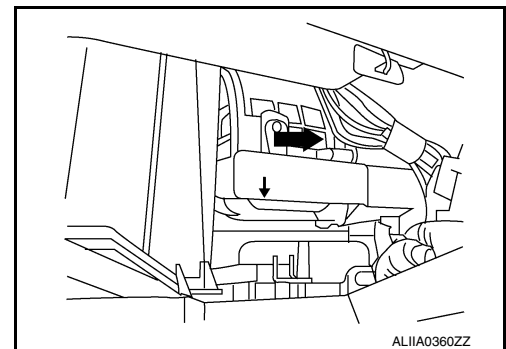

5. Install the in-cabin microfilter cover, make sure the tab is locked in place as shown.

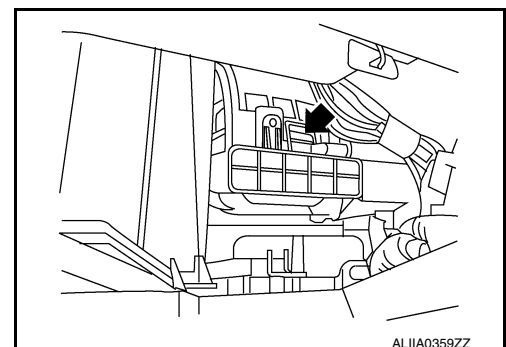

6. Close the lower glove box completely.

CONTROL UNIT

< REMOVAL AND INSTALLATION >

REMOVAL AND INSTALLATION

CONTROL UNIT

Removal and Installation

INFOID:000000009484329

FRONT AIR CONTROL

Removal

1. Remove cluster lid C. Refer to [IP-15. "Removal and Installation"](#).
2. Remove the front air control from cluster lid C.
 - Remove the four screws (A) that retain the front air control (1) to cluster lid C.

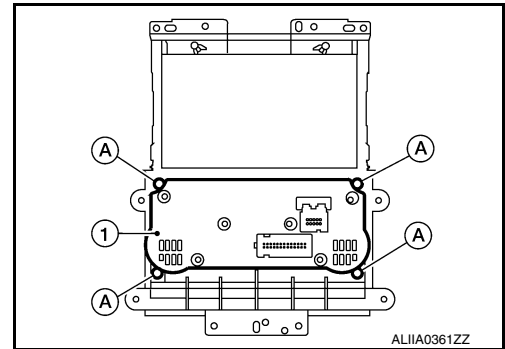

Installation

Installation is in the reverse order of removal.

A
B
C
D
E
F
G
H
J
K
L
M
N
O
P

VTL

INTAKE SENSOR

< REMOVAL AND INSTALLATION >

INTAKE SENSOR

Removal and Installation

INFOID:000000009484330

REMOVAL

1. Remove the front kick plate. Refer to [INT-18. "Removal and Installation"](#).
2. Remove the front pillar upper finisher. Refer to [INT-18. "Removal and Installation"](#).
3. Remove the upper glove box. Refer to [IP-18. "Removal and Installation"](#).

4. Disconnect the harness connector from the intake sensor.

NOTE:

The intake sensor is located on the top of the front heater and cooling unit assembly next to the A/C evaporator cover.

5. Twist the intake sensor to remove the intake sensor from the front heater and cooling unit assembly.

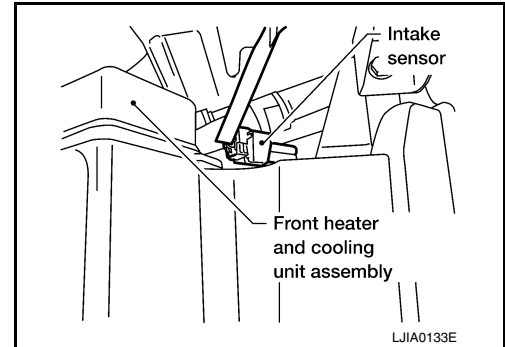

INSTALLATION

Installation is in the reverse order of removal.

BLOWER MOTOR

< REMOVAL AND INSTALLATION >

BLOWER MOTOR

Component

INFOID:000000009484331

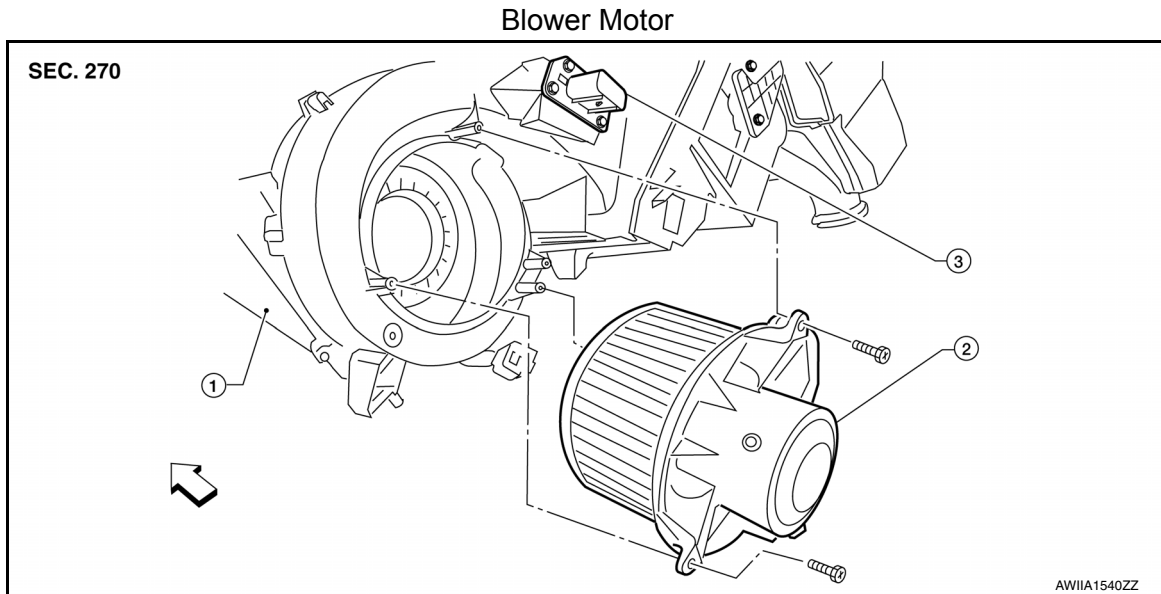

1. Heater and cooling unit assembly 2. Blower motor 3. Variable blower control/Blower motor resistor

⇐ Front

Removal and Installation

INFOID:000000009484332

FRONT BLOWER MOTOR

Removal

1. Remove the instrument lower panel RH and lower glove box assembly. Refer to [IP-19. "Removal and Installation"](#).
2. Disconnect the harness connector from the blower motor.
3. Remove the three blower motor screws and the front blower motor.

Installation

Installation is in the reverse order of removal.

A
B
C
D
E
F
G
H
J
K
L
M
N
O
P

VTL

VARIABLE BLOWER CONTROL

< REMOVAL AND INSTALLATION >

VARIABLE BLOWER CONTROL

Removal and Installation

INFOID:000000009484333

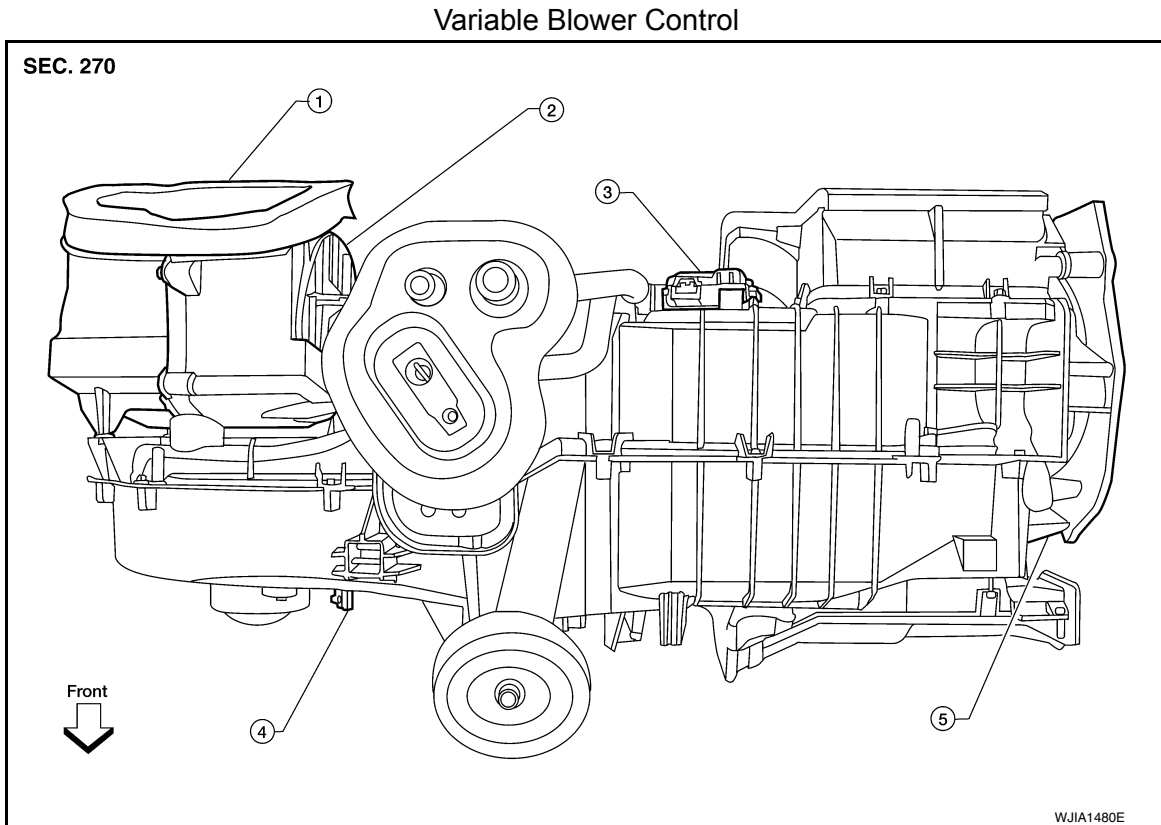

- | | | |
|-------------------------------------|----------------------|-----------------------|
| 1. Heater and cooling unit assembly | 2. Intake door motor | 3. Air mix door motor |
| 4. Variable blower control | 5. Mode door motor | |

REMOVAL

1. Disconnect the harness connector from the variable blower control.
2. Remove the two variable blower control screws and the variable blower control.

INSTALLATION

Installation is in the reverse order of removal.

FRONT BLOWER MOTOR RESISTOR

< REMOVAL AND INSTALLATION >

FRONT BLOWER MOTOR RESISTOR

Removal and Installation

INFOID:000000009484334

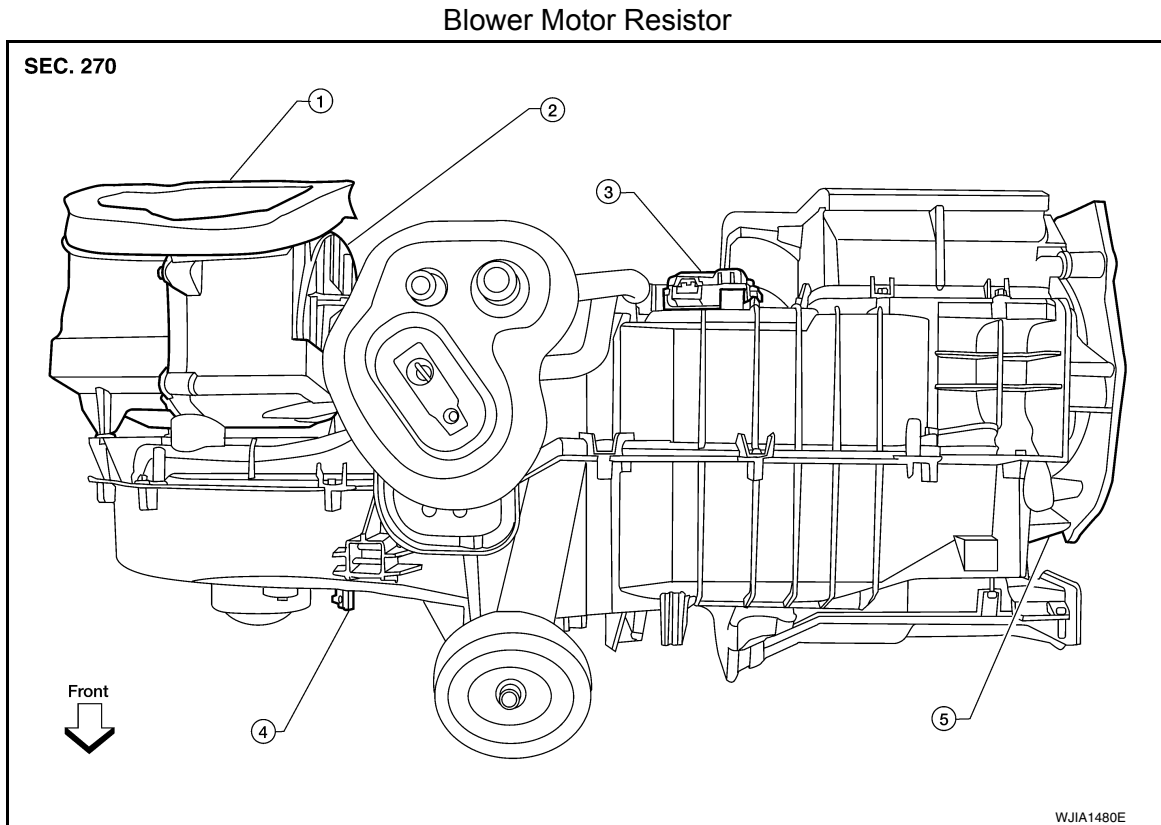

- | | | |
|-------------------------------------|----------------------|-----------------------|
| 1. Heater and cooling unit assembly | 2. Intake door motor | 3. Air mix door motor |
| 4. Blower motor resistor | 5. Mode door motor | |

REMOVAL

1. Disconnect the harness connector from the blower motor resistor.
2. Remove the two blower motor resistor screws and the blower motor resistor.

INSTALLATION

Installation is in the reverse order of removal.

A

B

C

D

E

F

G

H

VTL

J

K

L

M

N

O

P

HEATER & COOLING UNIT ASSEMBLY

< REMOVAL AND INSTALLATION >

HEATER & COOLING UNIT ASSEMBLY

Component

INFOID:000000009484335

Heater and Cooling Unit Assembly

SEC. 271 • 276 • 278

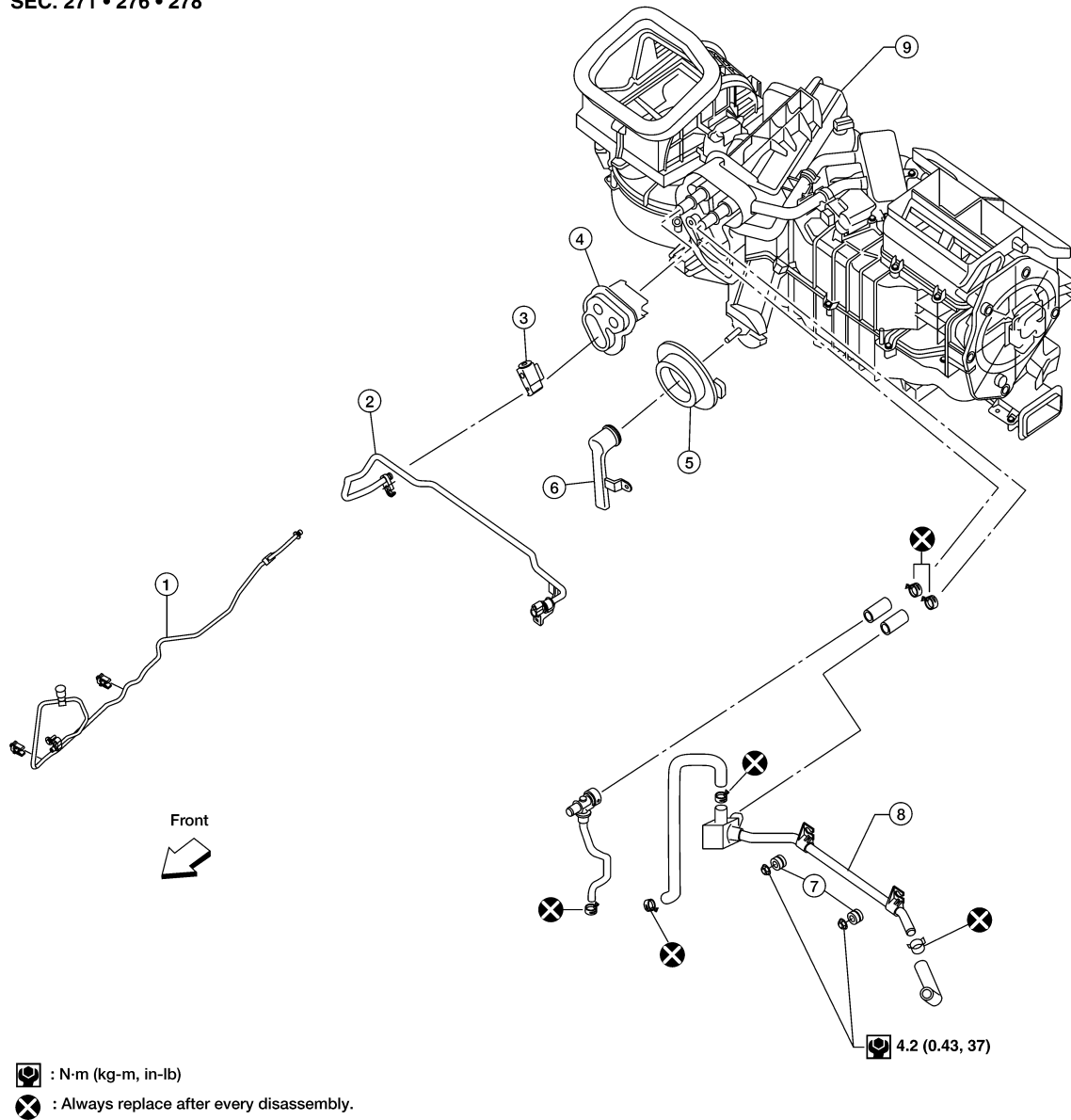

WJIA1621E

- | | | |
|---|---------------------------|-------------------------------------|
| 1. High-pressure A/C pipe | 2. Low-pressure A/C pipe | 3. Expansion valve |
| 4. Heater core and evaporator pipes grommet | 5. A/C drain hose grommet | 6. A/C drain hose |
| 7. Heater core pipe mounts | 8. Heater core pipes | 9. Heater and cooling unit assembly |

NOTE:

When removing components such as hoses, tubes/lines, etc., cap or plug openings to prevent fluid from spilling.

Removal and Installation

INFOID:000000009484336

HEATER AND COOLING UNIT ASSEMBLY

Removal

HEATER & COOLING UNIT ASSEMBLY

< REMOVAL AND INSTALLATION >

1. Discharge the refrigerant from the A/C system. Refer to [XX-XX, "*****"](#).
2. Drain the coolant from the engine cooling system. Refer to [CO-11, "Changing Engine Coolant"](#).
3. Disconnect the battery negative and positive terminals. Refer to [PG-73, "Battery"](#).
CAUTION:
Before servicing, turn the ignition switch off, disconnect both battery terminals and wait at least three minutes.
4. Remove the heater core pipes RH nut.
5. Disconnect the heater core hoses from the heater core.
6. Disconnect the high and low-pressure A/C pipes from the front expansion valve.
7. Remove the instrument panel assembly. Refer to [IP-11, "Removal and Installation"](#).
8. Remove the center console assembly. Refer to [IP-21, "Removal and Installation"](#).
9. Remove the two front floor ducts. Refer to [VTL-21, "Component"](#).
10. Remove the steering column. Refer to [ST-12, "Removal and Installation"](#).
11. Disconnect the instrument panel wire harness at the RH and LH in-line connector brackets, and the fuse block (SMJ) harness connectors.
12. Remove the covers then remove the three steering member bolts from each side to disconnect the steering member from the vehicle body.
13. Remove the heater and cooling unit assembly attached to the steering member from the vehicle.
CAUTION:
Use care not to damage the seats and interior trim panels when removing the heater and cooling unit assembly with it attached to the steering member.
14. Remove the front heater and cooling unit assembly from the steering member.

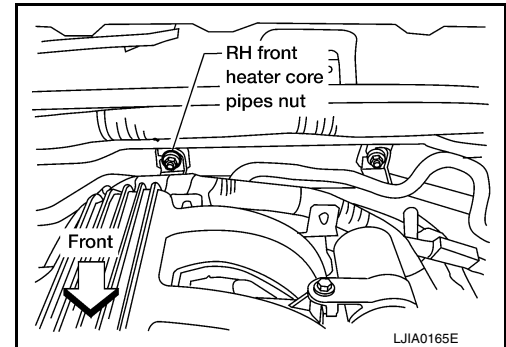

Installation

Installation is in the reverse order of removal.

- Fill the engine cooling system with the specified coolant mixture. Refer to [CO-11, "Changing Engine Coolant"](#).
- Recharge the A/C system. Refer to [XX-XX, "*****"](#).
- After installation, perform steering (angle) sensor adjustment. Refer to [BRC-12, "ADJUSTMENT OF STEERING ANGLE SENSOR NEUTRAL POSITION : Special Repair Requirement"](#) (TYPE1) or [BRC-122, "ADJUSTMENT OF STEERING ANGLE SENSOR NEUTRAL POSITION : Special Repair Requirement"](#) (TYPE 2).

CAUTION:

- Do not reuse O-rings.
- Apply A/C oil to the O-ring of the low-pressure A/C pipe and high-pressure A/C pipe for installation. Refer to [HA-25, "Component"](#).
- After charging the refrigerant, check for leaks. Refer to [HA-20, "Checking of Refrigerant Leaks"](#).

EVAPORATOR

< REMOVAL AND INSTALLATION >

EVAPORATOR

Removal and Installation

INFOID:000000009484337

Heater and Cooling Unit Assembly

SEC. 270

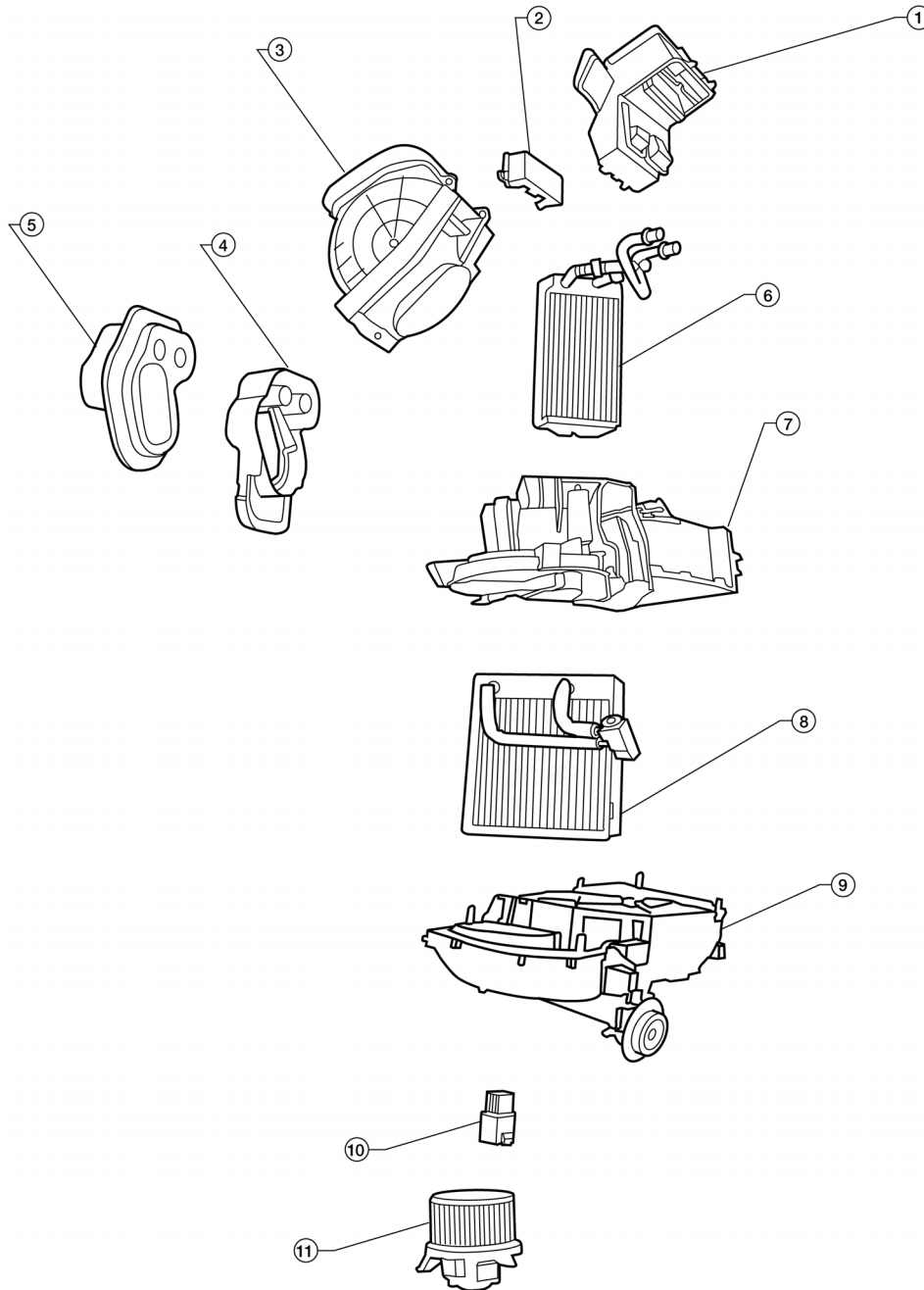

AWI1A1533ZZ

- | | | |
|---|---|---------------------------------------|
| 1. Center ventilator connector duct | 2. Heater core cover | 3. Intake air case |
| 4. Heater core and evaporator pipes bracket | 5. Heater core and evaporator pipes grommet | 6. Heater core |
| 7. Upper heater and cooling unit case | 8. Evaporator and expansion valve assembly | 9. Lower heater and cooling unit case |
| 10. Variable blower control/Blower motor resistor | 11. Blower motor | |

EVAPORATOR

< REMOVAL AND INSTALLATION >

REMOVAL

1. Remove the heater core. Refer to [VTL-17. "Removal and Installation"](#).
2. Separate the heater and cooling unit case.
3. Remove the evaporator and expansion valve assembly.

INSTALLATION

Installation is in the reverse order of removal.

CAUTION:

- **Do not reuse O-rings.**
- **Apply A/C oil to the O-rings on the A/C low-pressure flexible A/C hose and the high-pressure A/C pipe for installation.**

A
B
C
D
E
F
G
H
J
K
L
M
N
O
P

VTL

EXPANSION VALVE

< REMOVAL AND INSTALLATION >

EXPANSION VALVE

Removal and Installation

INFOID:000000009484338

REMOVAL AND INSTALLATION

For removal and installation of the expansion valve, refer to [HA-37. "Removal and Installation"](#).

HEATER CORE

< REMOVAL AND INSTALLATION >

HEATER CORE

Component

INFOID:000000009484339

Heater and Cooling Unit Assembly

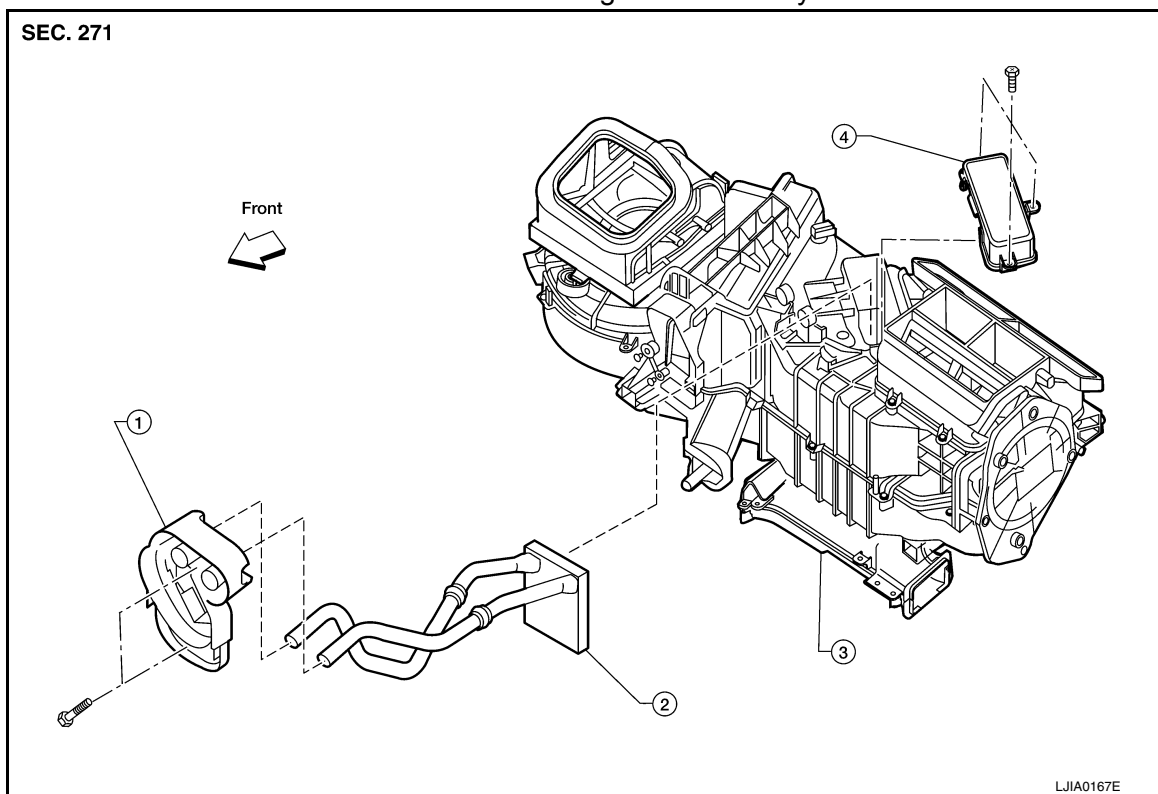

1. Heater core and evaporator pipe bracket
2. Heater core
3. Heater and cooling unit assembly
4. Heater core cover

Removal and Installation

INFOID:000000009484340

HEATER CORE

Removal

1. Remove the heater and cooling unit assembly. Refer to [VTL-12. "Removal and Installation"](#).
2. Remove the three heater core cover screws and the heater core cover.
3. Remove the heater core and evaporator pipe bracket.
4. Remove the heater core.

NOTE:

If the in-cabin microfilters are contaminated from coolant leaking from the heater core, replace the in-cabin microfilters with new ones before installing the new heater core.

Installation

Installation is in the reverse order of removal.

INTAKE DOOR MOTOR

< REMOVAL AND INSTALLATION >

INTAKE DOOR MOTOR

Removal and Installation

INFOID:000000009484341

Intake Door Motor - Heater and Cooling Unit Assembly

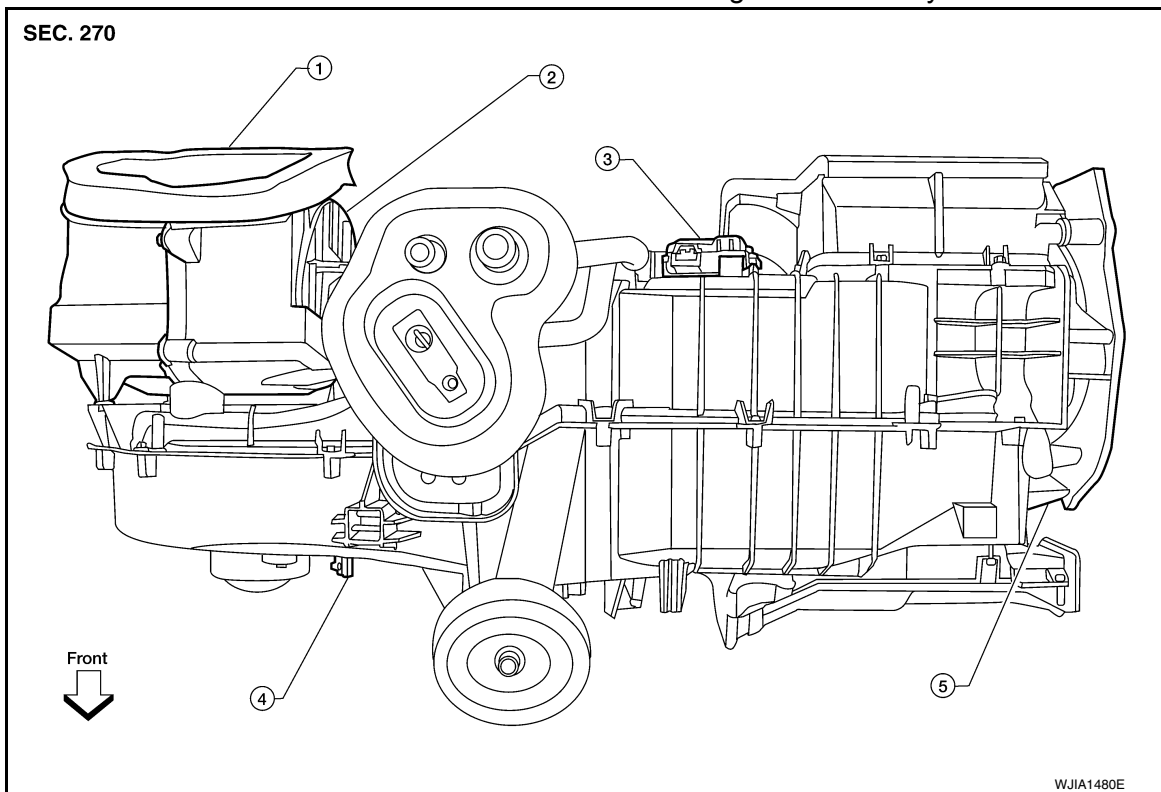

- | | | |
|--|----------------------|-----------------------|
| 1. Heater and cooling unit assembly | 2. Intake door motor | 3. Air mix door motor |
| 4. Variable blower control/Blower motor resistor | 5. Mode door motor | |

REMOVAL

1. Remove the heater and cooling unit assembly. Refer to [VTL-12, "Removal and Installation"](#).
2. Disconnect the harness connector from the intake door motor.
3. Remove the three intake door motor screws and the intake door motor.

INSTALLATION

Installation is in the reverse order of removal.

MODE DOOR MOTOR

< REMOVAL AND INSTALLATION >

MODE DOOR MOTOR

Removal and Installation

INFOID:000000009484342

Mode Door Motor - Heater and Cooling Unit Assembly

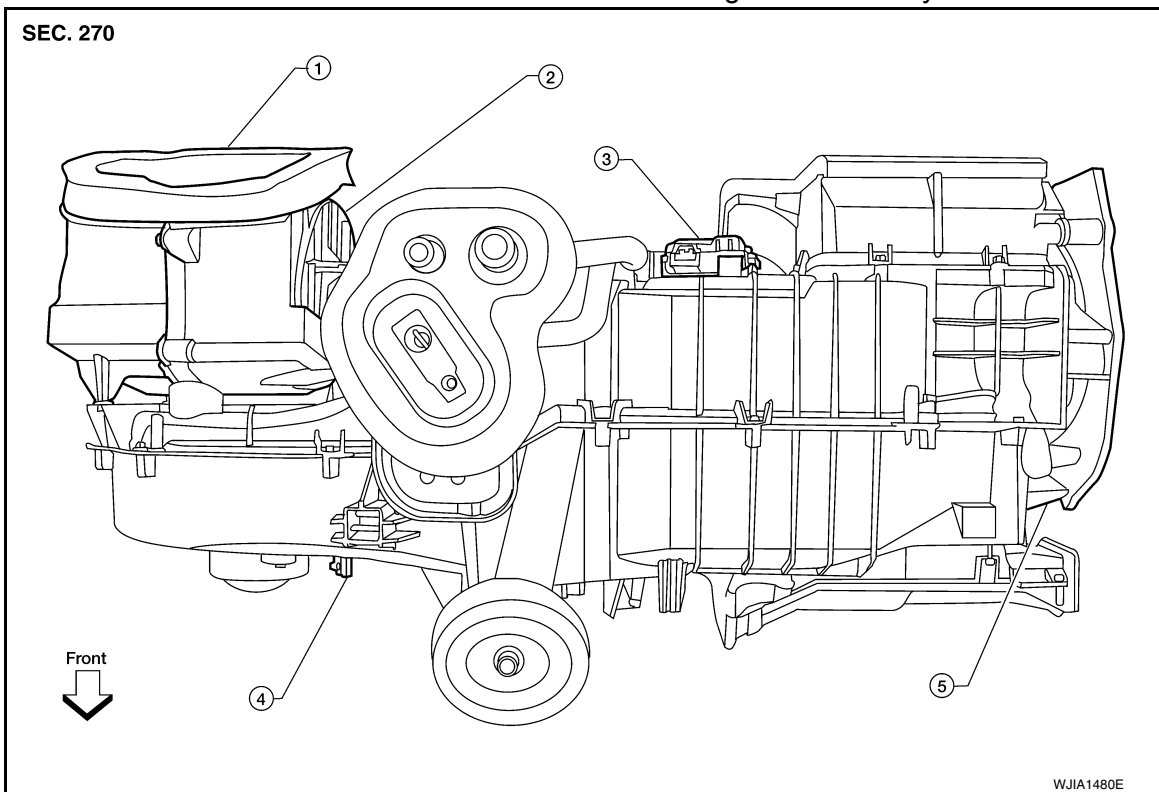

- | | | |
|--|----------------------|-----------------------|
| 1. Heater and cooling unit assembly | 2. Intake door motor | 3. Air mix door motor |
| 4. Variable blower control/Blower motor resistor | 5. Mode door motor | |

REMOVAL

1. Position the front door welt aside.
2. Remove the lower dash side finisher. Refer to [INT-18, "Removal and Installation"](#).
3. Remove the instrument lower panel LH. Refer to [IP-14, "Removal and Installation"](#).
4. Remove the BCM. Refer to [BCS-50, "Removal and Installation"](#).
5. Disconnect the harness connector from the mode door motor.
6. Remove the three mode door motor screws and the mode door motor.

INSTALLATION

Installation is in the reverse order of removal.

AIR MIX DOOR MOTOR

< REMOVAL AND INSTALLATION >

AIR MIX DOOR MOTOR

Removal and Installation

INFOID:000000009484343

Air Mix Door Motor - Heater and Cooling Unit Assembly

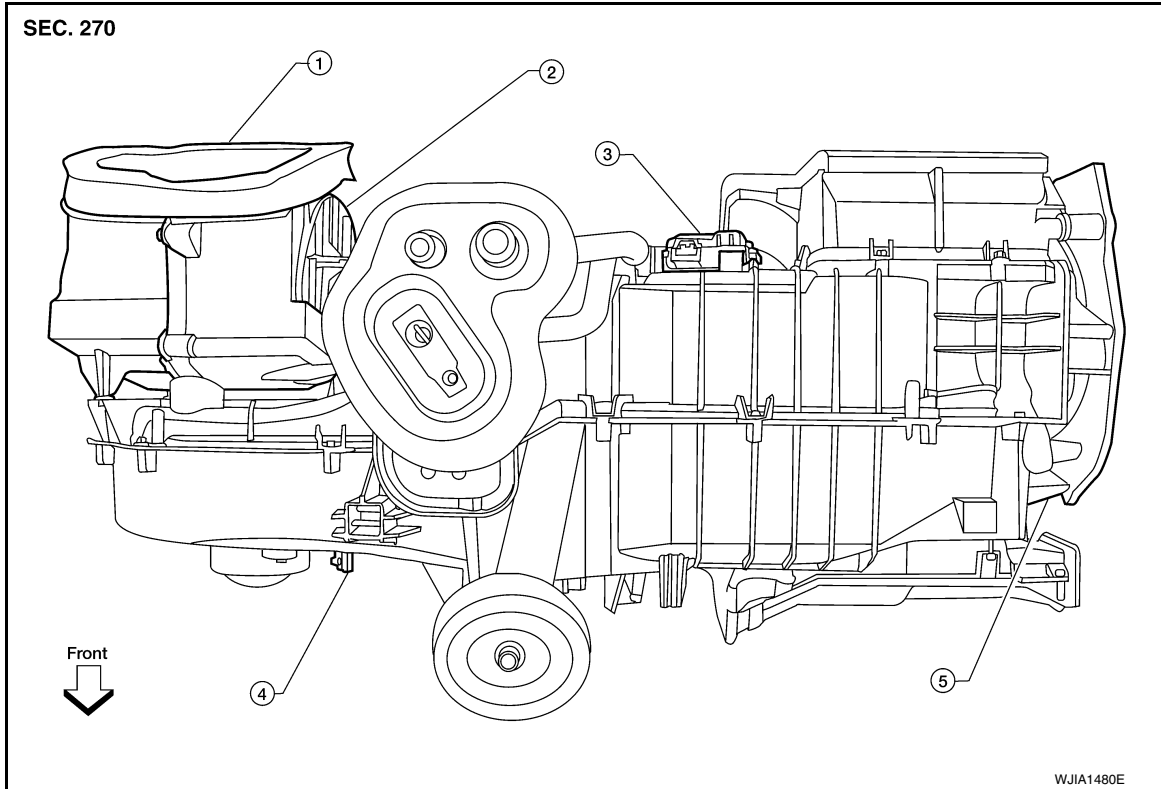

- | | | |
|--|----------------------|-----------------------|
| 1. Heater and cooling unit assembly | 2. Intake door motor | 3. Air mix door motor |
| 4. Variable blower control/Blower motor resistor | 5. Mode door motor | |

REMOVAL

1. Remove the heater and cooling unit assembly. Refer to [VTL-12, "Removal and Installation"](#).
2. Disconnect the harness connector from the air mix door motor.
3. Remove the three air mix door motor screws and the air mix door motor.

INSTALLATION

Installation is in the reverse order of removal.

DUCTS AND GRILLES

< REMOVAL AND INSTALLATION >

DUCTS AND GRILLES

Component

INFOID:000000009484344

SEC. 273

Ducts

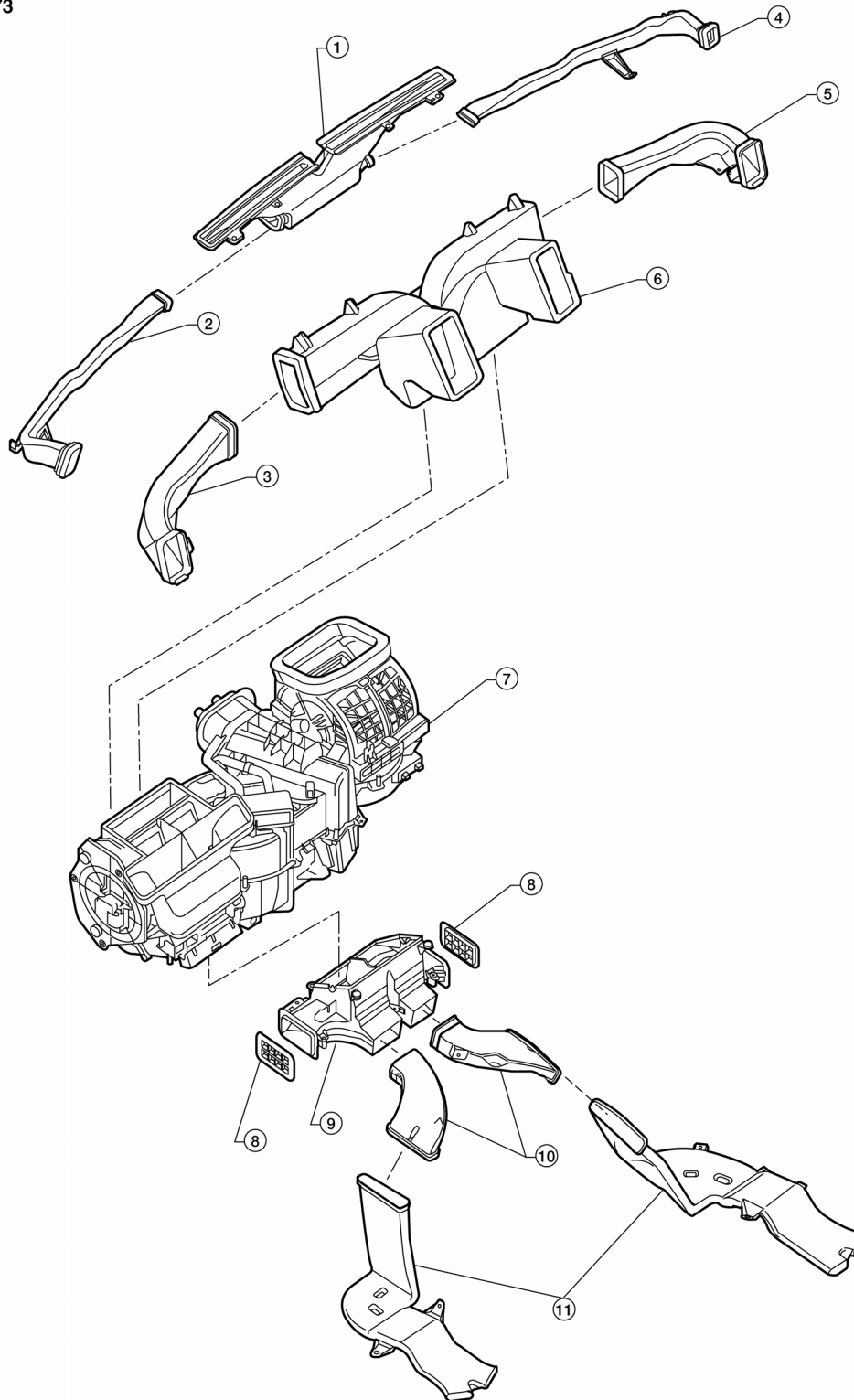

- 1. Defroster nozzle
- 4. Side demister duct (RH)

- 2. Side demister duct (LH)
- 5. Ventilator duct (RH)

- 3. Ventilator duct (LH)
- 6. Center ventilator duct

AWI1A1541ZZ

A
B
C
D
E
F
G
H
VTL
J
K
L
M
N
O
P

DUCTS AND GRILLES

< REMOVAL AND INSTALLATION >

- 7. Heater and cooling unit assembly
- 8. Floor connector duct grilles
- 9. Floor connector duct
- 10. Front floor ducts
- 11. Rear floor ducts

Grilles

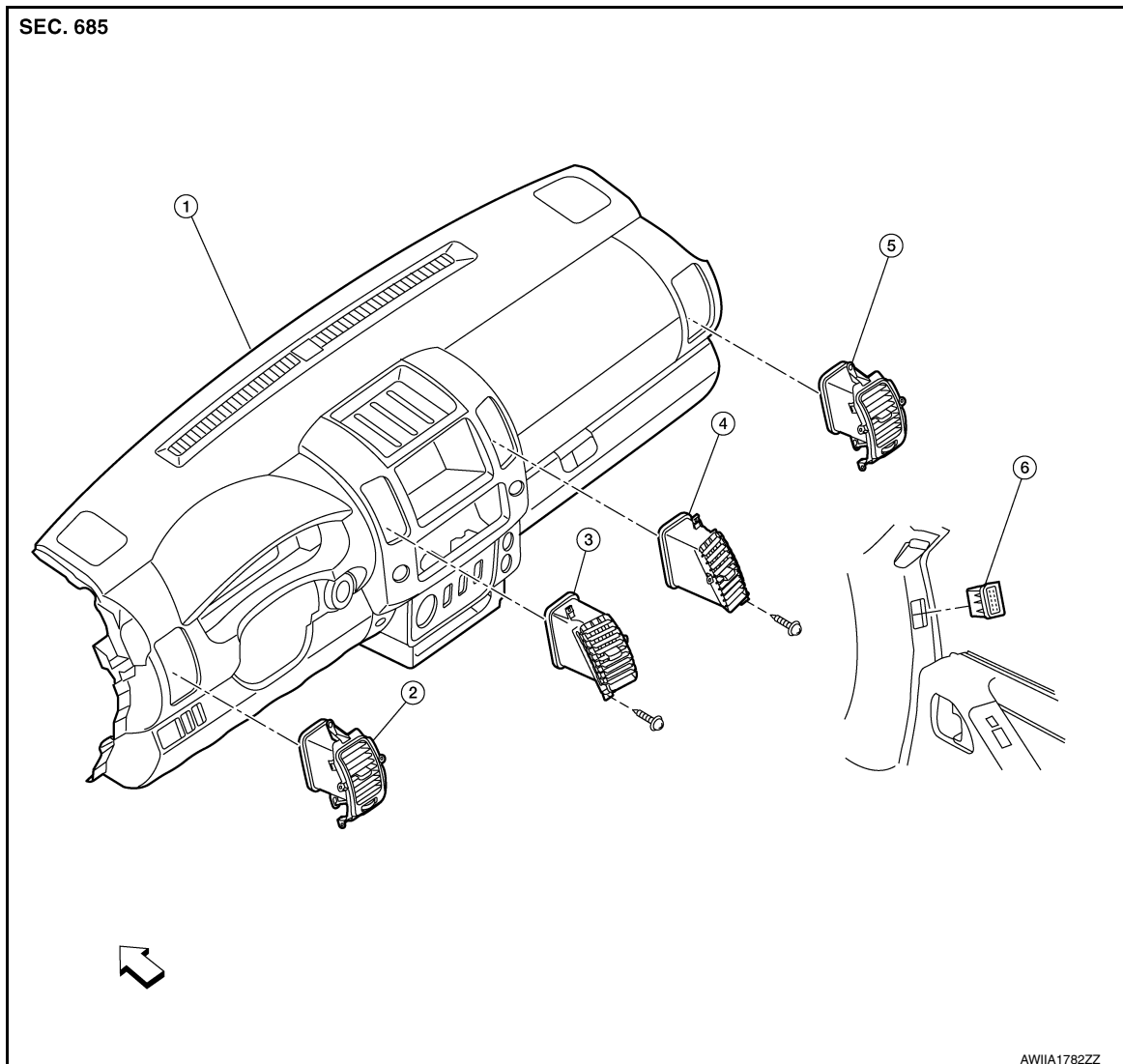

- 1. Instrument panel and pad assembly
- 2. Side ventilator grille (LH)
- 3. Ventilator grille (LH)
- 4. Ventilator grille (RH)
- 5. Side ventilator grille (RH)
- 6. Side demister grille (RH)

↔ Front

Removal and Installation

INFOID:000000009484345

DEFROSTER NOZZLE

Removal

1. Remove the heater and cooling unit assembly. Refer to [VTL-12, "Removal and Installation"](#).
2. Remove the defroster nozzle.

Installation

Installation is in the reverse order of removal.

RH AND LH SIDE DEMISTER DUCT

Removal

1. Remove the heater and cooling unit assembly. Refer to [VTL-12, "Removal and Installation"](#).
2. Remove the side demister duct.

DUCTS AND GRILLES

< REMOVAL AND INSTALLATION >

Installation

Installation is in the reverse order of removal.

RH AND LH VENTILATOR DUCT

Removal

1. Remove the heater and cooling unit assembly. Refer to [VTL-12, "Removal and Installation"](#).
2. Remove the ventilator duct.

Installation

Installation is in the reverse order of removal.

CENTER VENTILATOR DUCT

Removal

1. Remove the heater and cooling unit assembly. Refer to [VTL-12, "Removal and Installation"](#).
2. Remove the defroster nozzle.
3. Remove the ventilator ducts.
4. Remove the side demister ducts.
5. Remove the center ventilator duct.

Installation

Installation is in the reverse order of removal.

FLOOR CONNECTOR DUCT

Removal

1. Remove the heater and cooling unit assembly. Refer to [VTL-12, "Removal and Installation"](#).
2. Remove the floor connector duct.

Installation

Installation is in the reverse order of removal.

FRONT AND REAR FLOOR DUCTS

Removal

1. Remove the floor carpet. Refer to [INT-19, "Removal and Installation"](#).
2. Remove the clips and remove the front and rear floor ducts.

Installation

Installation is in the reverse order of removal.

GRILLES

Removal

1. Remove the necessary interior trim panel(s) to access the grille. Refer to [IP-10, "Exploded View"](#).
2. Remove the grille from the interior trim panel.

Installation

Installation is in the reverse order of removal.

A

B

C

D

E

F

G

H

VTL

J

K

L

M

N

O

P