

SECTION **SR**
SRS AIRBAG

A
B
C
D
E
F
G
SR
I
J
K
L
M
N
O
P

CONTENTS

BASIC INSPECTION	2	FRONT PASSENGER AIR BAG MODULE	15
COLLISION DIAGNOSIS	2	Removal and Installation	15
For Frontal Collision	2	SIDE CURTAIN AIR BAG MODULE	18
For Side and Rollover Collision	4	Removal and Installation	18
PRECAUTION	9	SIDE AIR BAG MODULE	19
PRECAUTIONS	9	Removal and Installation	19
Precaution for Supplemental Restraint System (SRS) "AIR BAG" and "SEAT BELT PRE-TEN- SIONER"	9	CRASH ZONE SENSOR	20
Service	9	Removal and Installation	20
Occupant Classification System Precaution	9	FRONT SEAT BELT PRE-TENSIONER	21
PREPARATION	10	Removal and Installation	21
PREPARATION	10	DIAGNOSIS SENSOR UNIT	22
Special Service Tool	10	Removal and Installation	22
REMOVAL AND INSTALLATION	11	OCCUPANT CLASSIFICATION SYSTEM CONTROL UNIT	24
DRIVER AIR BAG MODULE	11	Removal and Installation	24
Removal and Installation	11	SATELLITE SENSOR	25
SPIRAL CABLE	13	Removal and Installation - Side Air Bag (Satellite) Sensor	25
Removal and Installation	13	Removal and Installation - Front Door Satellite Sensor	26

COLLISION DIAGNOSIS

< BASIC INSPECTION >

BASIC INSPECTION

COLLISION DIAGNOSIS

For Frontal Collision

INFOID:000000011070207

FOR FRONTAL COLLISION: When SRS is activated in a collision

CAUTION:

Due to varying models and option levels, not all parts listed in the chart below apply to all vehicles.

WORK PROCEDURE

1. Before performing any of the following steps, ensure that all vehicle body and structural repairs have been completed.
2. Replace the diagnosis sensor unit.
3. Remove the front air bag modules, crash zone sensor assembly, bracket and seat belt pre-tensioner assemblies.
4. Check the SRS components using the table below:
Replace any SRS components showing visible signs of damage. (dents, cracks and deformation, etc.)
5. Install new front air bag modules, crash zone sensor assembly, bracket and seat belt pre-tensioner assemblies.
6. Perform self-diagnosis using CONSULT or air bag warning lamp. Refer to [SRC-15. "Self-Diagnosis Function \(Without CONSULT\)"](#) for details.
Ensure entire SRS operates properly.
7. After the work is completed, perform self-diagnosis to check that no malfunction is detected. Refer to [SRC-13. "SRS Operation Check"](#).

SRS INSPECTION (FOR FRONTAL COLLISION)

Part	Inspection
Driver air bag module	If the driver air bag has deployed: REPLACE Install with new fasteners.
Front passenger air bag module (if equipped)	If the front passenger air bag has deployed: REPLACE Install with new fasteners.
Crash zone sensor	If any of the front air bags or seat belt pre-tensioners* have been activated: REPLACE the crash zone sensor and bracket with new fasteners. *: Confirm seat belt pre-tensioner activation using CONSULT only.
Seat belt pre-tensioner assemblies (All applicable locations: buckle, retractor, lap outer)	If either the driver or passenger seat belt pre-tensioner* has been activated: REPLACE all seat belt pre-tensioner assemblies with new fasteners. *: Confirm seat belt pre-tensioner activation using CONSULT only.
Diagnosis sensor unit	If any of the SRS components have been activated: REPLACE the diagnosis sensor unit. Install with new fasteners.
Steering wheel	<ol style="list-style-type: none">1. Visually check steering wheel for deformities.2. Check harness (built into steering wheel) and connectors for damage, and terminals for deformities.3. Install driver air bag module into the steering wheel to check fit and alignment with the wheel.4. Check steering wheel for excessive free play.5. If no damage is found, reinstall.6. If damaged — REPLACE.
Spiral cable	If the driver front air bag has deployed: REPLACE the spiral cable.

COLLISION DIAGNOSIS

< BASIC INSPECTION >

Part	Inspection
Occupant classification system (Passenger seat)	<ol style="list-style-type: none"> 1. Remove passenger seat assembly. 2. Check control unit case for dents, cracks or deformities. 3. Check connectors for damage and terminals for deformities. 4. Check seat frame and cushion pan for dents or deformities. 5. If no damage is found, reinstall seat with new fasteners. 6. If damaged — REPLACE seat cushion assembly with new fasteners.
Harness and connectors	<ol style="list-style-type: none"> 1. Check connectors for poor connection, damage, and terminals for deformities. 2. Check harness for binding, chafing, cuts, or deformities. 3. If no damage is found, reinstall the harness and connectors. 4. If damaged — REPLACE the damaged harness. Do not attempt to repair, splice or modify any SRS harness.
Instrument panel assembly	If the passenger front air bag has deployed: REPLACE the instrument panel assembly. (integrated type)

FOR FRONTAL COLLISION: When SRS is not activated in a collision

CAUTION:

Due to varying models and option levels, not all parts listed in the chart below apply to all vehicles.

WORK PROCEDURE

1. Before performing any of the following steps, ensure that all vehicle body and structural repairs have been completed.
2. Check the SRS components using the table below:
Replace any SRS components showing visible signs of damage. (dents, cracks and deformation, etc.)
3. Perform self-diagnosis using CONSULT or air bag warning lamp. Refer to [SRC-15. "Self-Diagnosis Function \(Without CONSULT\)"](#) for details.
Ensure entire SRS operates properly.
4. After the work is completed, perform self-diagnosis to check that no malfunction is detected. Refer to [SRC-13. "SRS Operation Check"](#).

SRS INSPECTION (FOR FRONTAL COLLISION)

Part	Inspection
Driver air bag module	<p>If the driver air bag has NOT been activated:</p> <ol style="list-style-type: none"> 1. Remove driver air bag module. Check harness cover and connectors for damage, terminals for deformities, and harness for binding. 2. Install driver air bag module into the steering wheel to check fit and alignment with the wheel. 3. If no damage is found, reinstall with new fasteners. 4. If damaged — REPLACE. Install driver air bag modules with new fasteners.
Front passenger air bag module (if equipped)	<p>If the front passenger air bag has NOT been activated:</p> <ol style="list-style-type: none"> 1. Remove front passenger air bag module. Check harness cover and connectors for damage, terminals for deformities, and harness for binding. 2. Install front passenger air bag module into the instrument panel to check fit with the instrument panel. 3. If no damage is found, reinstall with new fasteners. 4. If damaged — REPLACE. Install front passenger air bag modules with new fasteners.
Crash zone sensor	<p>If the front air bags or seat belt pre-tensioners have NOT been activated:</p> <ol style="list-style-type: none"> 1. Remove the crash zone sensor. Check harness connectors for damage, terminals for deformities, and harness for binding. 2. Check for visible signs of damage (dents, cracks, deformation) of the crash zone sensor and bracket. 3. Install the crash zone sensor to check fit. 4. If no damage is found, reinstall with new fasteners. 5. If damaged — REPLACE the crash zone sensor and bracket with new fasteners.

COLLISION DIAGNOSIS

< BASIC INSPECTION >

Part	Inspection
Seat belt pre-tensioner assemblies (All applicable locations: buckle, retractor, lap outer)	<p>If the pre-tensioners have NOT been activated:</p> <ol style="list-style-type: none"> 1. Remove seat belt pre-tensioners. Check harness cover and connectors for damage, terminals for deformities, and harness for binding. 2. Check belts for damage and anchors for loose mounting. 3. Check retractor for smooth operation. 4. Check seat belt adjuster for damage. 5. Check for deformities of the center pillar inner. 6. If the center pillar inner has no damage, REPLACE the seat belt pre-tensioner assembly. 7. If no damage is found, reinstall seat belt pre-tensioner assembly. 8. If damaged —REPLACE. Install the seat belt pre-tensioners with new fasteners.
Diagnosis sensor unit	<p>If none of the SRS components have been activated:</p> <ol style="list-style-type: none"> 1. Check case for dents, cracks or deformities. 2. Check connectors for damage, and terminals for deformities. 3. If no damage is found, reinstall with new fasteners. 4. If damaged — REPLACE. Install diagnosis sensor unit with new fasteners.
Steering wheel	<ol style="list-style-type: none"> 1. Visually check steering wheel for deformities. 2. Check harness (built into steering wheel) and connectors for damage, and terminals for deformities. 3. Install driver air bag module into the steering wheel to check fit and alignment with the wheel. 4. Check steering wheel for excessive free play. 5. If no damage is found, reinstall. 6. If damaged — REPLACE.
Spiral cable	<p>If the driver front air bag has not deployed:</p> <ol style="list-style-type: none"> 1. Visually check spiral cable and combination switch for damage. 2. Check connectors and protective tape for damage. 3. Check steering wheel for noise, binding or heavy operation. 4. If no damage is found, reinstall. 5. If damaged — REPLACE.
Occupant classification system (Passenger seat)	<ol style="list-style-type: none"> 1. Remove passenger seat assembly. 2. Check control unit case for dents, cracks or deformities. 3. Check connectors for damage and terminals for deformities. 4. Check seat frame and cushion pan for dents or deformities. 5. If no damage is found, reinstall seat with new fasteners. 6. If damaged — REPLACE seat cushion assembly with new fasteners.
Harness and connectors	<ol style="list-style-type: none"> 1. Check connectors for poor connection, damage, and terminals for deformities. 2. Check harness for binding, chafing, cuts, or deformities. 3. If no damage is found, reinstall the harness and connectors. 4. If damaged —REPLACE the damaged harness. Do not attempt to repair, splice or modify any SRS harness.
Instrument panel assembly	<p>If the passenger front air bag has NOT deployed:</p> <ol style="list-style-type: none"> 1. Visually check instrument panel for damage. 2. If no damage is found, reinstall the instrument panel assembly. 3. If damaged—REPLACE the instrument panel assembly.

For Side and Rollover Collision

INFOID:000000011070208

FOR SIDE AND ROLLOVER COLLISION: When SRS is activated in a collision

CAUTION:

Due to varying models and option levels, not all parts listed in the chart below apply to all vehicles.

WORK PROCEDURE

1. Before performing any of the following steps, ensure that all vehicle body and structural repairs have been completed.
2. Replace the following components:
 - Front seat back assembly (on the side on which side air bag is activated).
 - Door finisher (on the side on which door-mounted curtain air bag is activated).
 - Pop-up roll bar assemblies and pop-up roll bar covers.
 - Side air bag (satellite) sensor LH/RH (on the side on which side air bag is activated).
 - Diagnosis sensor unit.
 - Seat belt pre-tensioner assemblies.

COLLISION DIAGNOSIS

< BASIC INSPECTION >

3. Check the SRS components and the related parts using the following table.
Replace any SRS components and the related parts showing visible signs of damage (dents, cracks, deformation, etc.).
4. Perform self-diagnosis using CONSULT and "AIR BAG" warning lamp. Refer to [SRC-13. "SRS Operation Check"](#) for details. Make sure entire SRS operates properly.
5. After the work is completed, perform self-diagnosis to check that no malfunction is detected. Refer to [SRC-15. "Trouble Diagnosis without CONSULT"](#).

SRS INSPECTION (FOR SIDE AND ROLLOVER COLLISION)

Part	Inspection
Side curtain air bag module LH	If the side curtain air bag LH has deployed: REPLACE the side curtain air bag module LH. Install with new fasteners.
Side curtain air bag module RH	If the side curtain air bag RH has deployed: REPLACE the side curtain air bag module RH. Install with new fasteners.
Front side air bag module LH	If the front side air bag LH has deployed: REPLACE front seatback assembly LH.
Front side air bag module RH	If the front side air bag RH has deployed: REPLACE front seatback assembly RH.
Side air bag (satellite) sensor (LH or RH)	If any of the SRS components have deployed: REPLACE the side air bag (satellite) sensor on the collision side with new fasteners.
Door (satellite) sensor (LH or RH)	If any of the SRS components have deployed: REPLACE the door (satellite) sensor on the collision side with new fasteners.
Diagnosis sensor unit	If any of the SRS components have deployed: REPLACE the diagnosis sensor unit with new fasteners.
Seat belt pre-tensioner assemblies (All applicable locations: buckle, retractor, lap outer)	If either the driver or passenger seat belt pre-tensioner* has been activated: REPLACE all seat belt pre-tensioner assemblies with new fasteners. *: Confirm seat belt pre-tensioner activation using CONSULT only.
Center inner pillar	1. Check the center inner pillar on the collision side for damage (dents, cracks, deformation). 2. If damaged —REPAIR the center inner pillar.
Seat (if equipped with front side air bag)	If either the front LH or front RH side air bag modules has been deployed: REPLACE front seatback assembly on the deployed side.
Trim/headlining	1. Check for visible signs of damage (dents, cracks, deformation) of the interior trim on the collision side. 2. If damaged — REPLACE the damaged trim parts.
Door-mounted curtain air bag module LH	If the door-mounted curtain air bag module LH has been deployed: REPLACE the door finisher LH and door-mounted curtain air bag module. Install with new fasteners.
Door-mounted curtain air bag module RH	If the door-mounted curtain air bag module RH has been deployed: REPLACE the door finisher RH and door-mounted curtain air bag module. Install with new fasteners.
Occupant classification system (Passenger seat)	1. Remove passenger seat assembly. 2. Check control unit case for dents, cracks or deformities. 3. Check connectors for damage and terminals for deformities. 4. Check seat frame and cushion pan for dents or deformities. 5. If no damage is found, reinstall seat with new fasteners. 6. If damaged — REPLACE seat cushion assembly with new fasteners.
Pop-up roll bar assemblies	If the pop-up roll bar has deployed: REPLACE pop-up roll bar assemblies and pop-up roll bar covers. Install with new fasteners.

FOR SIDE AND ROLLOVER COLLISION: When SRS is not activated in a collision

CAUTION:

Due to varying models and option levels, not all parts listed in the chart below apply to all vehicles.

WORK PROCEDURE

COLLISION DIAGNOSIS

< BASIC INSPECTION >

1. Before performing any of the following steps, ensure that all vehicle body and structural repairs have been completed.
2. Check the SRS components and the related parts using the following table.
 - If the front seat back assembly is damaged, the front seat back assembly must be replaced.
 - If the door finisher assembly is damaged, the door finisher assembly and door-mounted curtain air bag module must be replaced.
3. Perform self-diagnosis using CONSULT and "AIR BAG" warning lamp. Refer to [SRC-13. "SRS Operation Check"](#) for details. Make sure entire SRS operates properly.
4. After the work is completed, perform self-diagnosis to check that no malfunction is detected. Refer to [SRC-15. "Trouble Diagnosis without CONSULT"](#).

SRS INSPECTION (FOR SIDE AND ROLLOVER COLLISION)

Part	Inspection
Side curtain air bag module LH	If the side curtain air bag LH has NOT deployed: <ol style="list-style-type: none"> 1. Check for visible signs of damage (dents, tears, deformation) of the center pillar on the collision side. 2. If damaged - Remove the side curtain air bag module LH. 3. Check for visible signs of damage (tears etc.) of the side curtain air bag module LH. 4. Check harness and connectors for damage, and terminals for deformities. 5. If no damage is found, reinstall the side curtain air bag module LH with new fasteners. 6. If damaged — REPLACE the side curtain air bag module LH with new fasteners.
Side curtain air bag module RH	If the side curtain air bag RH has NOT deployed: <ol style="list-style-type: none"> 1. Check for visible signs of damage (dents, tears, deformation) of the center pillar on the collision side. 2. If damaged - Remove the side curtain air bag module RH. 3. Check for visible signs of damage (tears etc.) of the side curtain air bag module RH. 4. Check harness and connectors for damage, and terminals for deformities. 5. If no damage is found, reinstall the side curtain air bag module RH with new fasteners. 6. If damaged — REPLACE the side curtain air bag module RH with new fasteners.
Front side air bag module LH	If the front LH side air bag has NOT deployed: <ol style="list-style-type: none"> 1. Check for visible signs of damage (dents, tears, deformation) of the seat back on the collision side. 2. Check harness and connectors for damage, and terminals for deformities. 3. If damaged — REPLACE the front seatback assembly LH.
Front side air bag module RH	If the front side air bag RH has NOT deployed: <ol style="list-style-type: none"> 1. Check for visible signs of damage (dents, tears, deformation) of the seat back on the collision side. 2. Check harness and connectors for damage, and terminals for deformities. 3. If damaged — REPLACE the front seatback assembly RH.
Side air bag (satellite) sensor (LH or RH)	If none of the SRS components have been activated: <ol style="list-style-type: none"> 1. Remove the side air bag (satellite) sensor (LH or RH) on the collision side. Check harness connectors for damage, terminals for deformities, and harness for binding. 2. Check for visible signs of damage (dents, cracks, deformation) of the side air bag (satellite) sensor (LH or RH). 3. Install the side air bag (satellite) sensor (LH or RH) to check fit. 4. If no damage is found, reinstall the side air bag (satellite) sensor (LH or RH) with new fasteners. 5. If damaged — REPLACE the side air bag (satellite) sensor (LH or RH) with new fasteners.
Door (satellite) sensor (LH or RH)	If none of the SRS components have been activated: <ol style="list-style-type: none"> 1. Remove the door (satellite) sensor (LH or RH) on the collision side. Check harness connectors for damage, terminals for deformities, and harness for binding. 2. Check for visible signs of damage (dents, cracks, deformation) of the door (satellite) sensor (LH or RH). 3. Install the door (satellite) sensor (LH or RH) to check fit. 4. If no damage is found, reinstall the door (satellite) sensor (LH or RH) with new fasteners. 5. If damaged — REPLACE the door (satellite) sensor (LH or RH) with new fasteners.
Diagnosis sensor unit	If none of the SRS components have been activated: <ol style="list-style-type: none"> 1. Check case and bracket for dents, cracks or deformities. 2. Check connectors for damage, and terminals for deformities. 3. If no damage is found, reinstall the diagnosis sensor unit with new fasteners. 4. If damaged — REPLACE the diagnosis sensor unit with new fasteners.

COLLISION DIAGNOSIS

< BASIC INSPECTION >

Part	Inspection	
Seat belt pre-tensioner assemblies (All applicable locations: buckle, retractor, lap outer)	If the pre-tensioners have NOT been activated: 1. Remove seat belt pre-tensioners. Check harness cover and connectors for damage, terminals for deformities, and harness for binding. 2. Check belts for damage and anchors for loose mounting. 3. Check retractor for smooth operation. 4. Check seat belt adjuster for damage. 5. Check for deformities of the center pillar inner. 6. If the center pillar inner has no damage, REPLACE the seat belt pre-tensioner assembly. 7. If no damage is found, reinstall seat belt pre-tensioner assembly. 8. If damaged —REPLACE. Install the seat belt pre-tensioners with new fasteners.	A B C
Seat (with front side air bag)	If the front LH or front RH side air bag modules have NOT deployed: 1. Visually check the seat on the collision side. 2. Remove the seat on the collision side and check the following for damage and deformities. - Harness, connectors and terminals - Frame and recliner (for front and rear seat), and also adjuster and slides (for front seat) 3. If no damage is found, reinstall the seat. 4. If damaged— REPLACE the damaged seat parts using new fasteners. If the front seat back is damaged, the front seat back assembly must be replaced.	D E F
Center inner pillar	1. Check the center inner pillar on the collision side for damage (dents, cracks, deformation, etc.). 2. If damaged - REPAIR the center inner pillar.	G
Trim/headlining	1. Check for visible signs of damage (dents, cracks, deformation, etc.) of the interior trim on the collision side. 2. If damaged - REPLACE the damaged trim parts.	SR
Door-mounted curtain air bag module LH	If the door-mounted curtain air bag LH has NOT deployed: 1. Check for visible signs of damage (dents, tears, deformation, etc.) of the door finisher on the collision side. 2. If damaged - REPLACE the door finisher LH with new fasteners. 3. Check for visible signs of damage (tears etc.) of the door-mounted curtain air bag module LH. 4. Check harness and connectors for damage, and terminals for deformities. 5. If no damage is found, reinstall door finisher. CAUTION: When removing door mounted curtain air bag module from door finisher, do not reuse door finisher. 6. If damaged - REPLACE the door finisher LH and door-mounted curtain air bag module LH with new fasteners.	I J K
Door-mounted curtain air bag module RH	If the door-mounted curtain air bag RH has NOT deployed: 1. Check for visible signs of damage (dents, tears, deformation, etc.) of the door finisher on the collision side. 2. If damaged - REPLACE the door finisher RH with new fasteners. 3. Check for visible signs of damage (tears etc.) of the door-mounted curtain air bag module RH. 4. Check harness and connectors for damage, and terminals for deformities. 5. If no damage is found, reinstall door finisher. CAUTION: When removing door mounted curtain air bag module from door finisher, do not reuse door finisher. 6. If damaged - REPLACE the door finisher RH and door-mounted curtain air bag module RH with new fasteners.	L M N

COLLISION DIAGNOSIS

< BASIC INSPECTION >

Part	Inspection
Occupant classification system (Passenger seat)	<ol style="list-style-type: none">1. Remove passenger seat assembly.2. Check control unit case for dents, cracks or deformities.3. Check connectors for damage and terminals for deformities.4. Check seat frame and cushion pan for dents or deformities.5. If no damage is found, reinstall seat with new fasteners.6. If damaged — REPLACE seat cushion assembly with new fasteners.
Pop-up roll bar	<p>If the pop-up roll bar NOT deployed:</p> <ol style="list-style-type: none">1. Check for visible signs of damage (dents, tears, deformation, etc.) of the pop-up roll bar.2. If damaged - REPLACE the pop-up roll bar with new fasteners.3. Check harness and connectors for damage, and terminals for deformities.4. If no damage is found, reinstall the pop-up roll bar with new fasteners.5. Check for visible signs of damage (dents, cracks, deformation, etc.) of the seatback support brace assembly.6. If damaged - REPAIR the seatback support brace assembly.

PRECAUTIONS

< PRECAUTION >

PRECAUTION

PRECAUTIONS

Precaution for Supplemental Restraint System (SRS) "AIR BAG" and "SEAT BELT PRE-TENSIONER"

INFOID:000000011070209

The Supplemental Restraint System such as "AIR BAG" and "SEAT BELT PRE-TENSIONER", used along with a front seat belt, helps to reduce the risk or severity of injury to the driver and front passenger for certain types of collision. This system includes seat belt switch inputs and dual stage front air bag modules. The SRS system uses the seat belt switches to determine the front air bag deployment, and may only deploy one front air bag, depending on the severity of a collision and whether the front occupants are belted or unbelted. Information necessary to service the system safely is included in the SR and SB section of this Service Manual.

WARNING:

- To avoid rendering the SRS inoperative, which could increase the risk of personal injury or death in the event of a collision which would result in air bag inflation, all maintenance must be performed by an authorized NISSAN/INFINITI dealer.
- Improper maintenance, including incorrect removal and installation of the SRS, can lead to personal injury caused by unintentional activation of the system. For removal of Spiral Cable and Air Bag Module, see the SR section.
- Do not use electrical test equipment on any circuit related to the SRS unless instructed to in this Service Manual. SRS wiring harnesses can be identified by yellow and/or orange harnesses or harness connectors.

PRECAUTIONS WHEN USING POWER TOOLS (AIR OR ELECTRIC) AND HAMMERS

WARNING:

- When working near the Airbag Diagnosis Sensor Unit or other Airbag System sensors with the Ignition ON or engine running, DO NOT use air or electric power tools or strike near the sensor(s) with a hammer. Heavy vibration could activate the sensor(s) and deploy the air bag(s), possibly causing serious injury.
- When using air or electric power tools or hammers, always switch the Ignition OFF, disconnect the battery and wait at least three minutes before performing any service.

Service

INFOID:000000011070210

- Do not use electrical test equipment to check SRS circuits unless instructed to in this Service Manual.
- Before servicing the SRS, turn ignition switch OFF, disconnect both battery cables and wait at least 3 minutes.
For approximately 3 minutes after the cables are removed, it is still possible for the air bag and seat belt pretensioner to deploy. Therefore, do not work on any SRS connectors or wires until at least 3 minutes have passed.
- The air bag diagnosis sensor unit must always be installed with the arrow mark "←" pointing toward the front of the vehicle for proper operation. Also check the air bag diagnosis sensor unit for cracks, deformities or rust before installation and replace as required.
- The spiral cable must be aligned with the neutral position since its rotations are limited. Do not attempt to turn steering wheel or column after removal of steering gear.
- Handle air bag module carefully. Always place driver and front passenger air bag modules with the pad side facing upward and seat mounted front side air bag module standing with the stud bolt side facing down.
- Conduct self-diagnosis to check entire SRS for proper function after replacing any components.
- After air bag inflates, the front instrument panel assembly should be replaced if damaged.

Occupant Classification System Precaution

INFOID:000000011070211

Replace control unit and passenger front seat cushion as an assembly.

PREPARATION

< PREPARATION >

PREPARATION

PREPARATION

Special Service Tool

INFOID:000000011070212

The actual shape of the tools may differ from those illustrated here.

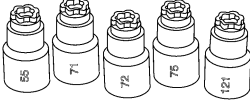
Tool number (TechMate No.) Tool name	Description
— (J-42057-UPD) Air bag key set Part of kit (J-42057)  LRS210	Removing and installing air bag lock

DRIVER AIR BAG MODULE

< REMOVAL AND INSTALLATION >

REMOVAL AND INSTALLATION

DRIVER AIR BAG MODULE

Removal and Installation

INFOID:0000000011070213

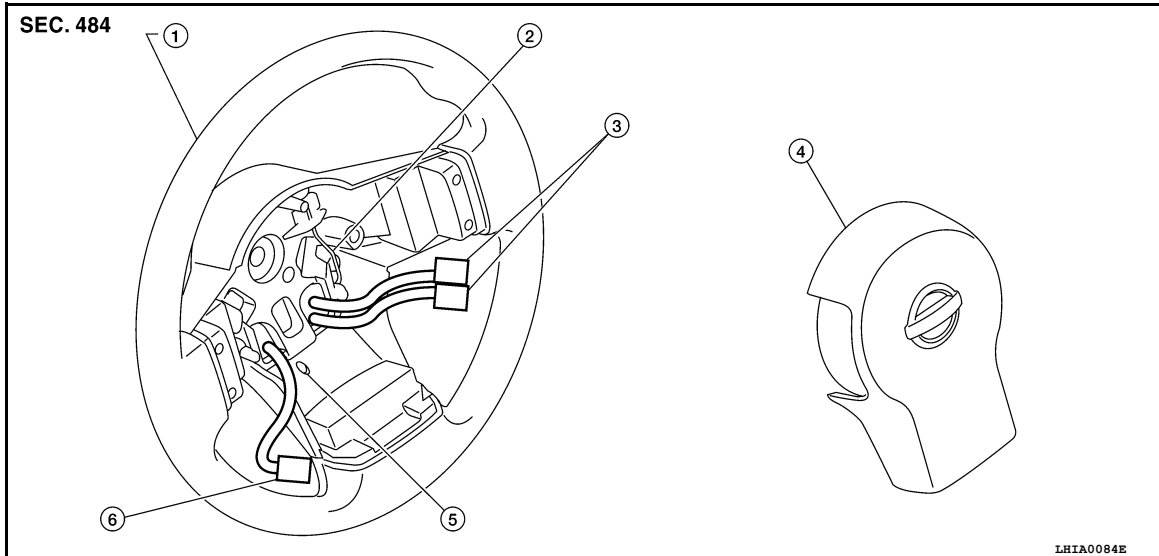

- | | | |
|--------------------------|-------------------------------|-------------------------------------|
| 1. Steering wheel | 2. Retaining clip | 3. Driver air bag module connectors |
| 4. Driver air bag module | 5. Retaining clip access hole | 6. Horn connector |

REMOVAL

CAUTION:

- Do not attempt to repair or replace damaged direct-connect SRS component connectors. If a driver air bag direct-connect harness connector is damaged, the spiral cable must be replaced.
- Before servicing the SRS, turn ignition switch OFF, disconnect both battery terminals and wait at least three minutes.
- When servicing the SRS, do not work from directly in front of air bag module.

1. Disconnect the negative and positive battery terminals, then wait at least three minutes. Refer to [PG-77, "Removal and Installation"](#).
2. Locate retaining clip access hole and insert suitable 4mm - 6mm blunt tool.

NOTE:

Do not use sharp edged objects such as screwdrivers to release driver air bag module from steering wheel, SRS components may be unintentionally damaged.

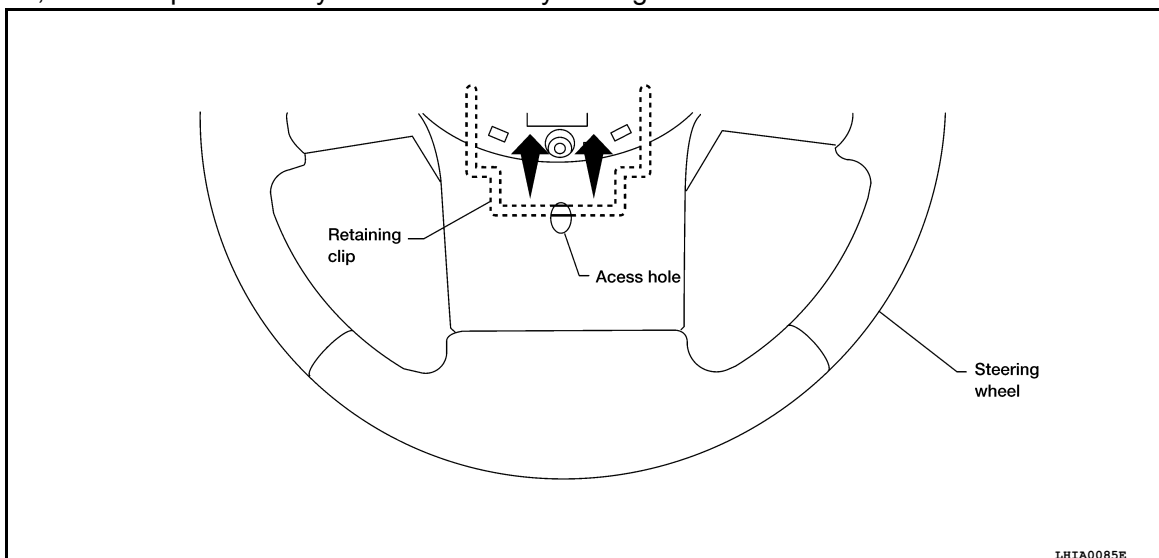

DRIVER AIR BAG MODULE

< REMOVAL AND INSTALLATION >

3. Press upward (toward center of steering wheel) on retaining clip until driver air bag module is released from steering wheel.
4. Lift the driver air bag module from the steering wheel.
5. Disconnect the harness connectors from the driver air bag module and horn, then remove the driver air bag module.
 - For removal/installation of the direct-connect SRS connectors, refer to [SRC-9. "Direct-connect SRS Component Connectors"](#).

CAUTION:

- When servicing the SRS, do not work from directly in front of air bag module.
- Always place air bag module with pad side facing upward.
- Do not insert any foreign objects (screwdriver, etc.) into air bag module or connectors.
- Do not disassemble air bag module.
- Do not expose the air bag module to temperatures exceeding 90°C (194°F).

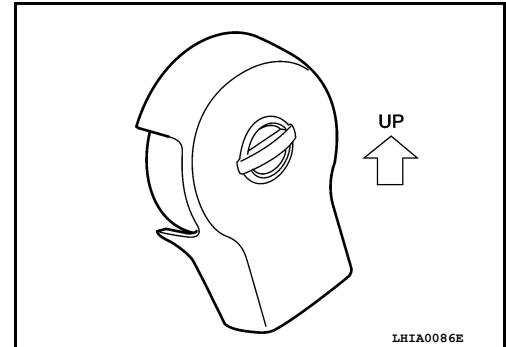

- Replace the air bag module if it has been dropped or sustained an impact.
- Do not allow oil, grease or water to come in contact with the air bag module.



INSTALLATION

Installation is in the reverse order of installation.

- If driver air bag module is being replaced due to deployment, spiral cable must also be replaced. Refer to [SR-13. "Removal and Installation"](#).
- For removal/installation of the direct-connect SRS connectors, refer to [SRC-9. "Direct-connect SRS Component Connectors"](#).
- After the work is completed, perform self-diagnosis to check that no malfunction is detected. Refer to [SRC-13. "SRS Operation Check"](#).

SPIRAL CABLE

< REMOVAL AND INSTALLATION >

SPIRAL CABLE

Removal and Installation

INFOID:000000011070214

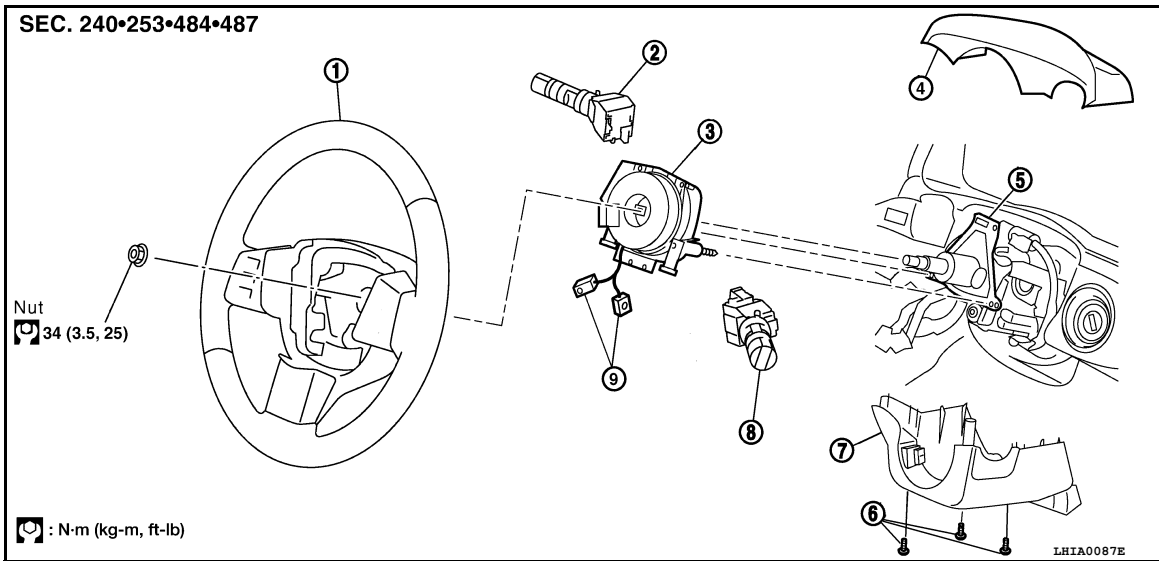

- | | | |
|--------------------------------|------------------------------------|-------------------------------------|
| 1. Steering wheel | 2. Lighting and turn signal switch | 3. Spiral cable |
| 4. Steering column upper cover | 5. Steering column assembly | 6. Screw |
| 7. Steering column lower cover | 8. Wiper and washer switch | 9. Driver air bag module connectors |

REMOVAL

CAUTION:

• Before servicing the SRS, turn ignition switch OFF, disconnect both battery terminals and wait at least three minutes.

• When servicing the SRS, do not work from directly in front of air bag module.

1. Disconnect the negative and positive battery terminals, then wait at least three minutes. Refer to [PG-77, "Removal and Installation"](#).
2. Set the front wheels in the straight-ahead position.
3. Remove the steering wheel. Refer to [ST-11, "Removal and Installation"](#).
4. Remove the steering column upper and lower covers. Refer to [IP-12, "Removal and Installation"](#).
5. Disconnect the harness connector from the wiper and washer switch. Then while pressing tabs, pull wiper and washer switch away from spiral cable to remove.

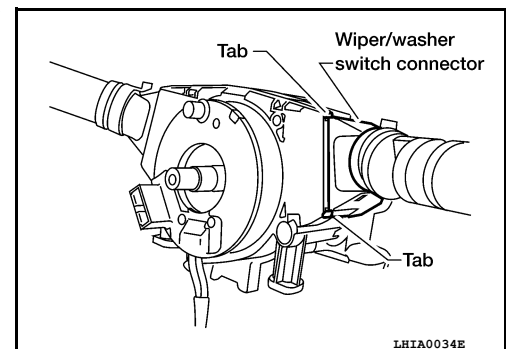

SPIRAL CABLE

< REMOVAL AND INSTALLATION >

6. Disconnect the harness connector from the lighting and turn signal switch. Then while pressing tabs, pull lighting and turn signal switch toward driver door to remove.

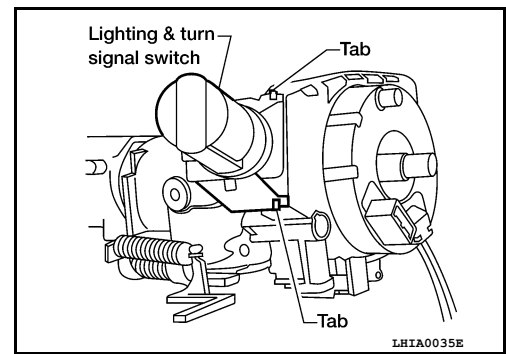

7. Remove the screws. Then while pressing the tab, pull the spiral cable away from steering column assembly.

CAUTION:

- Do not disassemble spiral cable.
- Do not apply lubricant to the spiral cable.

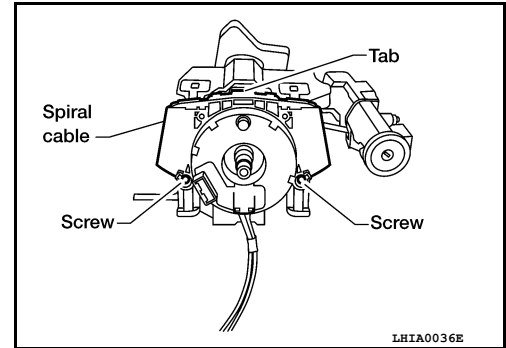

8. Disconnect the harness connectors from the spiral cable.

CAUTION:

With the steering linkage disconnected, the spiral cable may snap by turning the steering wheel beyond the limited number of turns. The spiral cable can be turned counterclockwise about 2.5 turns from the neutral position.

9. Remove the steering angle sensor from the spiral cable. Refer to [BRC-116, "Removal and Installation"](#) for TYPE 1, or [BRC-238, "Removal and Installation"](#) for TYPE 2 systems.

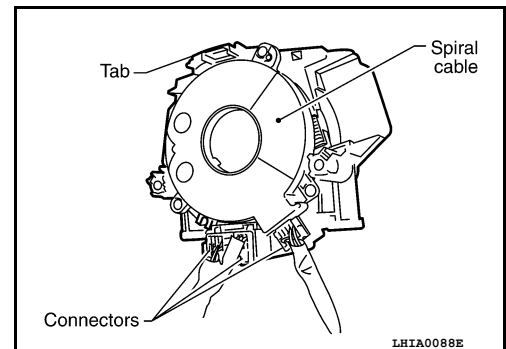

INSTALLATION

Installation is in the reverse order of removal.

- Align spiral cable correctly when installing steering wheel, refer to [ST-11, "Removal and Installation"](#). Make sure that the spiral cable is in the neutral position. The neutral position is detected by turning left 2.5 revolutions from the right end position and ending with the locating pin at the top.
- Reset the steering angle sensor calibration after installing spiral cable. Refer to [BRC-12, "ADJUSTMENT OF STEERING ANGLE SENSOR NEUTRAL POSITION : Special Repair Requirement"](#).
- After the work is completed, perform self-diagnosis to make sure no malfunction is detected. Refer to [SRC-13, "SRS Operation Check"](#).

CAUTION:

- The spiral cable may snap due to steering operation if the cable is not installed in the correct position.
- With the steering linkage disconnected, the cable may snap by turning the steering wheel beyond the limited number of turns. The spiral cable can be turned counterclockwise about 2.5 turns from the neutral position.

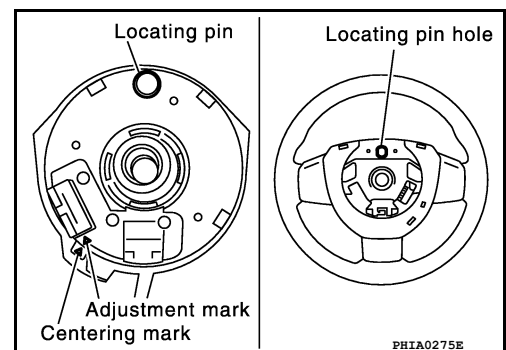

FRONT PASSENGER AIR BAG MODULE

< REMOVAL AND INSTALLATION >

FRONT PASSENGER AIR BAG MODULE

Removal and Installation

INFOID:000000011070215

The passenger air bag module originally installed in the vehicle uses direct-connect style harness connectors. Service replacement passenger air bag modules use tab-locking style harness connectors. If the passenger air bag module is replaced or if the direct-connect harness connectors are damaged, the vehicle wiring harness must be modified to allow connection of the service replacement passenger air bag module. Follow the "WIRING HARNESS MODIFICATION" procedure.

REMOVAL

CAUTION:

- Do not attempt to repair or replace damaged direct-connect front passenger air bag module connectors. If a direct-connect harness connector is damaged, the front passenger air bag must be replaced and the wiring harness modified.
- Before servicing SRS, turn the ignition switch off, disconnect both battery terminals and wait at least three minutes.
- Always work from the side of or under front passenger air bag module.

1. Disconnect the negative and positive battery terminals, then wait at least three minutes. Refer to [PG-77, "Removal and Installation"](#).
2. Remove the upper glove box. Refer to [IP-18, "Removal and Installation"](#).
3. Remove two bolts (through glove box opening) retaining front passenger air bag module to the steering member.
4. Disconnect the harness connectors from the passenger air bag module.
 - For removal/installation of the direct-connect SRS connectors, refer to [SRC-9, "Direct-connect SRS Component Connectors"](#).
5. Remove the instrument panel assembly from the vehicle. Refer to [IP-11, "Removal and Installation"](#).

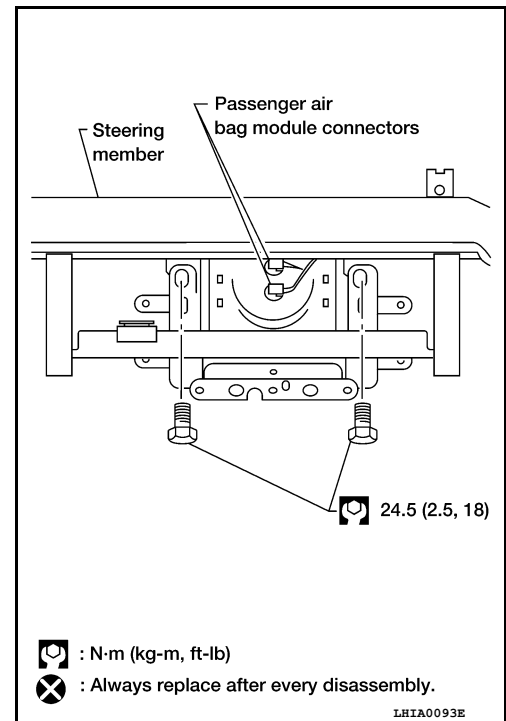

6. Remove front passenger air bag module screws then remove passenger air bag module from instrument panel assembly.

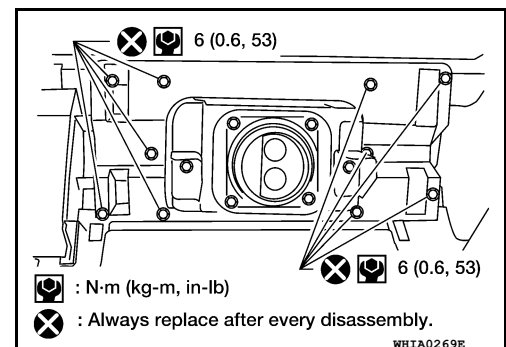

CAUTION:

FRONT PASSENGER AIR BAG MODULE

< REMOVAL AND INSTALLATION >

- When servicing the SRS, do not work from directly in front of air bag module.
- Always place front passenger air bag module with caution label side facing upward.
- Do not insert any foreign objects (screwdriver, etc.) into air bag module or harness connectors.
- Do not disassemble air bag module.
- Do not use old nuts after removal; replace with new nuts.
- Do not expose the front passenger air bag module to temperatures exceeding 90°C (194°F).

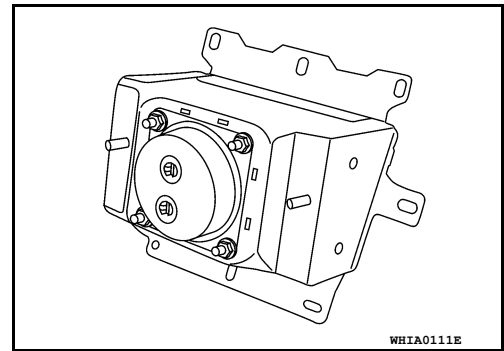

- Replace the air bag module if it has been dropped or sustained an impact.
- Do not allow oil, grease or water to come in contact with the air bag module.
- For removal/installation of the direct-connect SRS connectors, refer to [SRC-9, "Direct-connect SRS Component Connectors"](#).

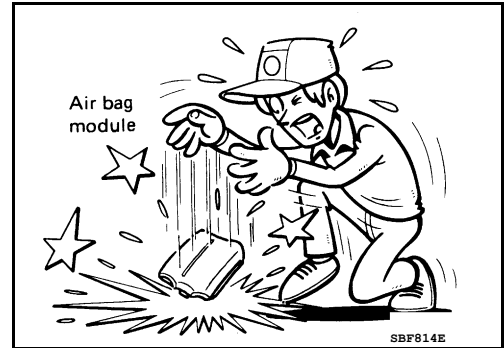

INSTALLATION

Original Passenger Air Bag Module

Installation is in the reverse order of removal.

- For removal/installation of the direct-connect SRS connectors, refer to [SRC-9, "Direct-connect SRS Component Connectors"](#).

CAUTION:

- Always work from the side of or under front passenger air bag module.
- After the work is completed, perform self-diagnosis to check that no malfunction is detected. Refer to [SRC-13, "SRS Operation Check"](#).

Service Replacement Passenger Air Bag Module

1. Install the front passenger air bag module to the instrument panel pad assembly.

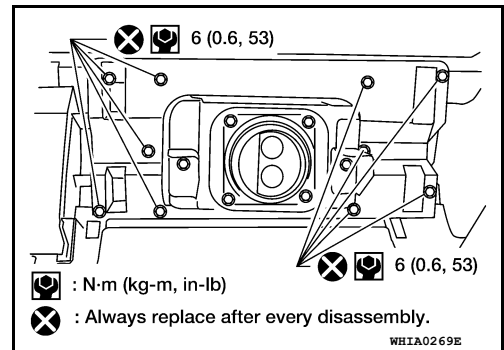

2. Install the instrument panel assembly. Refer to [IP-11, "Removal and Installation"](#).
3. Connect the front passenger air bag module harness connector to yellow 4-pin service replacement air bag connector and fasten connector to mounting bracket.

CAUTION:

- Always work from the side of or under front passenger air bag module.
- After the work is completed, perform self-diagnosis to check that no malfunction is detected. Refer to [SRC-13, "SRS Operation Check"](#).

WIRING HARNESS MODIFICATION

The passenger air bag module originally installed in the vehicle uses direct-connect style harness connectors. Service replacement passenger air bag modules use tab-locking style harness connectors. If the passenger

FRONT PASSENGER AIR BAG MODULE

< REMOVAL AND INSTALLATION >

air bag module is replaced or if the direct-connect harness connectors are damaged, the vehicle wiring harness must be modified to allow connection of the service replacement passenger air bag module.

NOTE:

The wiring harness modification is to be performed only if the vehicle is equipped with the original passenger air bag which uses direct-connect harness connectors. If the passenger air bag is to be replaced in a vehicle that has already had the service replacement passenger air bag installed, the wiring harness modification is not required.

CAUTION:

- Do not attempt to repair or replace damaged direct-connect front passenger air bag module connectors. If a direct-connect harness connector is damaged, the front passenger air bag must be replaced and the wiring harness modified.
- Before servicing SRS, turn the ignition switch off, disconnect both battery terminals and wait at least three minutes.
- Always work from the side of or under front passenger air bag module.
- After the work is completed, perform self-diagnosis to check that no malfunction is detected. Refer to [SRC-13, "SRS Operation Check"](#).

1. Locate the yellow and orange direct-connect passenger air bag module harness connectors.
2. Use wire cutters to cut back both previously used direct-connect passenger air bag module harness connectors from the vehicle wiring harness approximately 50 mm (1.9 in) from the connectors.
3. Remove approximately 150 mm (5.9 in) of the vehicle harness covering from the cut end.
4. Slide a piece of dual-wall heat shrink tubing (provided in the passenger air bag service kit) onto each wire of the previously used vehicle wiring harness.

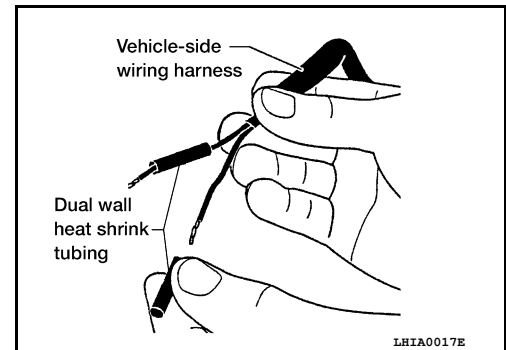

5. Fold each wire back and insert into the end of the heat shrink tubing so that the end of the wire is approximately centered in the heat shrink tubing.

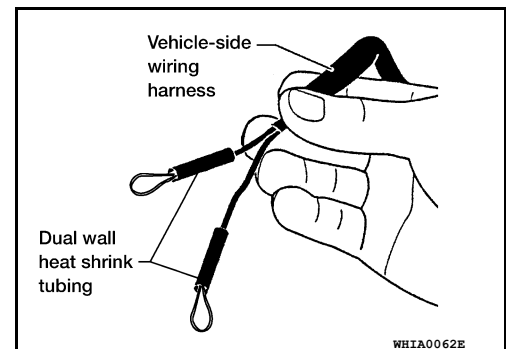

6. Use a heat gun to shrink the heat shrink tubing and seal the wire.
7. Use electrical tape to secure the modified circuits to the outside of the wiring harness.
8. Locate the front passenger air bag service replacement connector that is taped back to the main harness. Unwrap the tape to access the yellow service replacement connector and remove the dust cover from the connector.

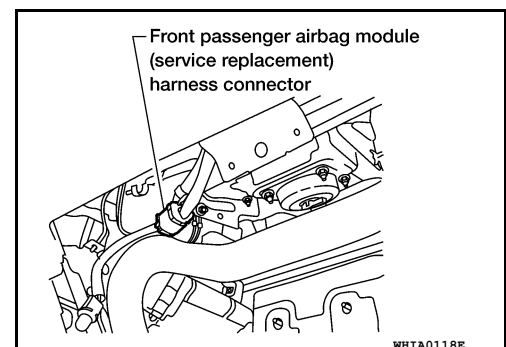

A
B
C
D
E
F
G
SR
I
J
K
L
M
N
O
P

SIDE CURTAIN AIR BAG MODULE

< REMOVAL AND INSTALLATION >

SIDE CURTAIN AIR BAG MODULE

Removal and Installation

INFOID:000000011070216

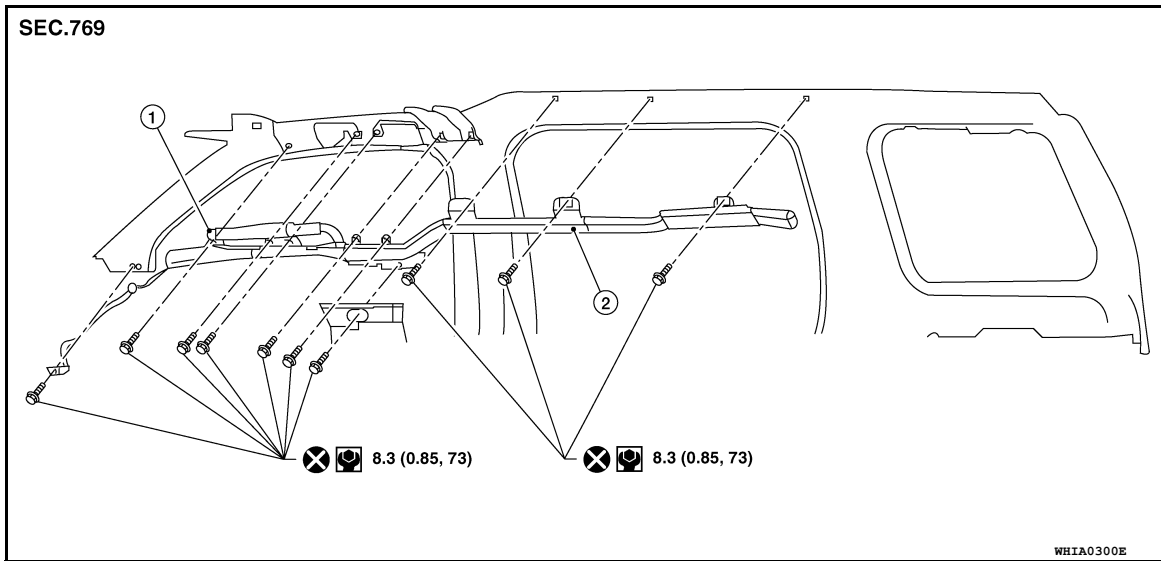

1. Side curtain air bag module connector 2. Side curtain air bag module

REMOVAL

CAUTION:

- Do not attempt to repair or replace damaged direct-connect SRS component connectors. If a direct-connect harness connector is damaged, the harness must be replaced.
- Before servicing the SRS, turn the ignition switch off, disconnect both battery terminals and wait at least three minutes.
- When servicing the SRS, do not work from directly in front of air bag module.

1. Remove the headlining. Refer to [INT-21, "Removal and Installation"](#).
2. Disconnect the harness connectors from the front and rear side curtain air bag module.
 - For removal/installation of the direct-connect SRS connectors, refer to [SRC-9, "Direct-connect SRS Component Connectors"](#).
3. Remove the bolts in order starting at the front, then remove the side curtain air bag module.

CAUTION:

- When servicing the SRS, do not work from directly in front of air bag module.
- Do not insert any foreign objects (screwdriver, etc.) into air bag module or harness connectors.
- Do not disassemble air bag module.
- Do not expose the air bag module to temperatures exceeding 90°C (194°F).
- Replace side curtain air bag module if it has been dropped or sustained an impact.
- Do not allow oil, grease or water to come in contact with the air bag module.

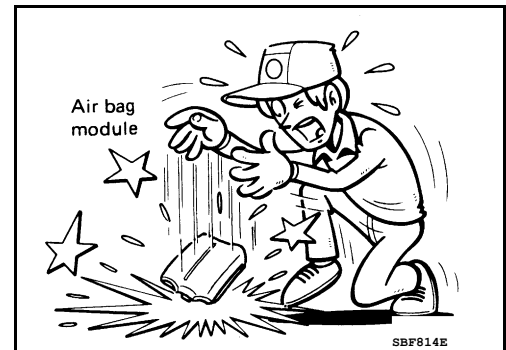

INSTALLATION

Installation is in the reverse order of removal.

- For removal/installation of the direct-connect SRS connectors, refer to [SRC-9, "Direct-connect SRS Component Connectors"](#).
- After replacement of side curtain air bag module, perform self-diagnosis to check that no malfunction is detected. Refer to [SRC-13, "SRS Operation Check"](#).

SIDE AIR BAG MODULE

< REMOVAL AND INSTALLATION >

SIDE AIR BAG MODULE

Removal and Installation

INFOID:000000011070217

For side air bag module removal and installation, the front seatback must be disassembled, refer to [SE-33](#), "[Disassembly and Assembly](#)".

NOTE:

If the vehicle has been involved in a collision and the side air bag has deployed, the front seatback assembly must be replaced.

A
B
C
D
E
F
G
SR
I
J
K
L
M
N
O
P

CRASH ZONE SENSOR

< REMOVAL AND INSTALLATION >

CRASH ZONE SENSOR

Removal and Installation

INFOID:000000011070218

REMOVAL

CAUTION:

Before servicing the SRS, turn the ignition switch off, disconnect both battery terminals and wait at least three minutes.

1. Disconnect the negative and positive battery terminals, then wait at least three minutes. Refer to [PG-77](#), "[Removal and Installation](#)".
2. Remove crash zone sensor nuts and shield from support member.
3. Disconnect the harness connector from the crash zone sensor.
4. Remove crash zone sensor.

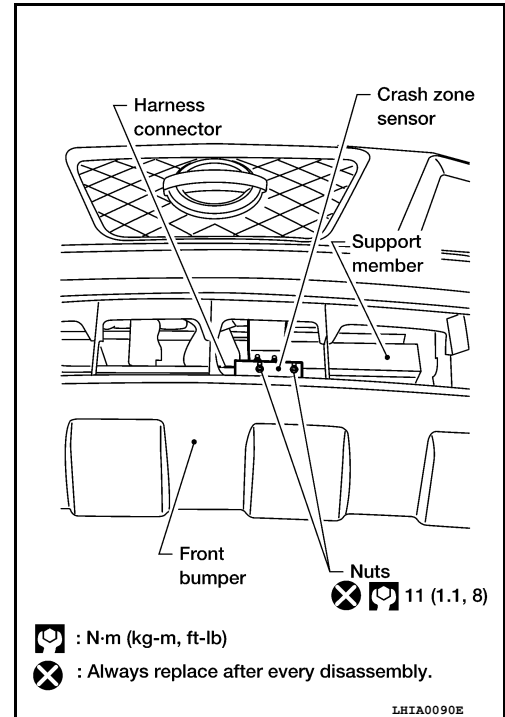

CAUTION:

- Replace crash zone sensor if it has been dropped or sustained an impact.
- Do not disassemble crash zone sensor.

INSTALLATION

Installation is in the reverse order of removal.

- After the work is complete, perform self-diagnosis to check that no malfunction is detected. Refer to [SRC-13](#), "[SRS Operation Check](#)".

FRONT SEAT BELT PRE-TENSIONER

< REMOVAL AND INSTALLATION >

FRONT SEAT BELT PRE-TENSIONER

Removal and Installation

INFOID:000000011070220

For removal and installation procedures, refer to [SB-6. "Removal and Installation of Front Seat Belt"](#).

- A
- B
- C
- D
- E
- F
- G
- SR**
- I
- J
- K
- L
- M
- N
- O
- P

DIAGNOSIS SENSOR UNIT

< REMOVAL AND INSTALLATION >

DIAGNOSIS SENSOR UNIT

Removal and Installation

INFOID:000000011070221

REMOVAL

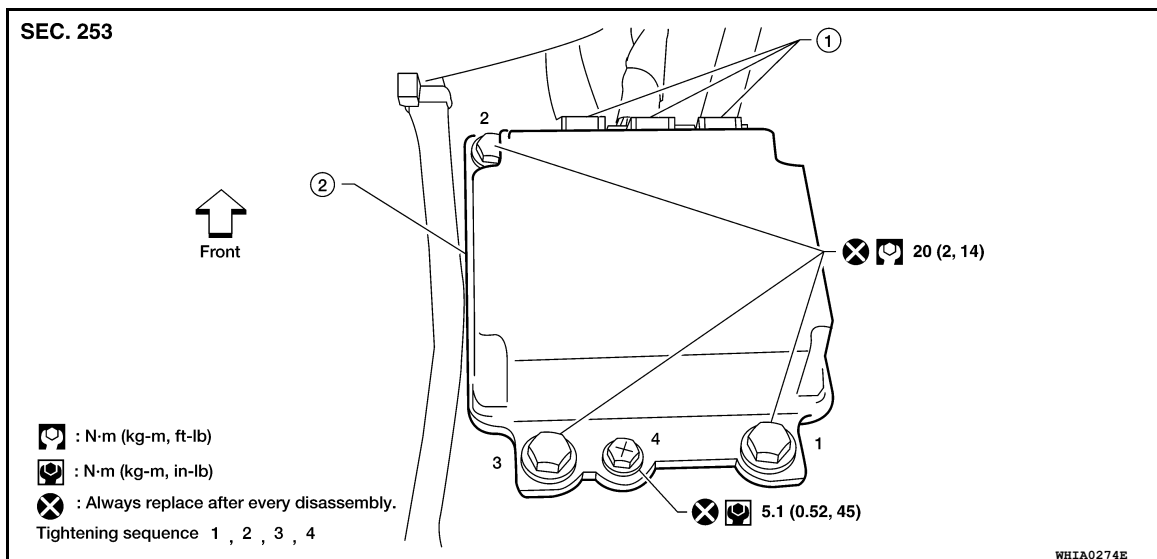

1. Diagnosis sensor unit connectors
2. Diagnosis sensor unit

CAUTION:

- Do not remove, flip or rotate the air bag diagnosis sensor unit while powered by ignition power feed. Doing so may cause unintended air bag deployment.
- Before servicing the SRS, turn the ignition switch off, disconnect both battery terminals and wait at least three minutes.
- Do not use old bolts; replace with new bolts.
- Check diagnosis sensor unit bracket to make sure it is free of deformities, dents, cracks or rust. If it shows any visible signs of damage, replace with new one.
- Replace diagnosis sensor unit if it has been dropped or sustained an impact.
- Do not use air tools or electric tools for servicing.
- When replacing the air bag diagnosis sensor unit, always check with the parts department for the latest parts information. Installing an incorrect air bag diagnosis sensor unit may or may not cause the air bag warning lamp to illuminate and may cause incorrect deployment of the supplemental air bags and seat belt pre-tensioner in a collision resulting in serious personal injury or death.

1. Always check the air bag diagnosis sensor unit ECU discriminated number (identification number) or part number using CONSULT.
2. Disconnect the negative and positive battery terminals, then wait at least three minutes. Refer to [PG-77, "Removal and Installation"](#).
3. Disconnect the harness connectors for the following SRS components: Refer to [SR-18, "Removal and Installation"](#) (Side curtain air bag module), [SE-33, "Disassembly and Assembly"](#) (Side air bag module), [SB-6, "Removal and Installation of Front Seat Belt"](#) (Seat belt pre-tensioner).
4. Remove center console assembly. Refer to [IP-21, "Removal and Installation"](#).
5. Disconnect the harness connectors from the diagnosis sensor unit.
6. Remove bolts from the diagnosis sensor unit.

CAUTION:

Replace diagnosis sensor unit if it has been dropped or sustained an impact.

INSTALLATION

Installation is in the reverse order of removal.

- Always follow the tightening sequence shown.
- After the work is completed, perform self-diagnosis to check that no malfunction is detected. Refer to [SRC-13, "SRS Operation Check"](#).

CAUTION:

DIAGNOSIS SENSOR UNIT

< REMOVAL AND INSTALLATION >

- Do not use old bolts; replace with new bolts.
- Check diagnosis sensor unit bracket to ensure it is free of deformities, dents, cracks or rust. If it shows any visible signs of damage, replace with new one.
- The diagnosis sensor unit must always be installed with the arrow mark "←" pointing toward the front of the vehicle for proper operation.
- When installing diagnosis sensor unit bolt, use proper tightening sequence.
- Do not damage the harness while installing.
- If malfunction is detected by the air bag warning lamp after repair or replacement of the malfunctioning parts, reset the memory using self-diagnosis or CONSULT. Refer to [SRC-15, "Self-Diagnosis Function \(Without CONSULT\)"](#).
- After the work is completed, check that no system malfunction is detected by air bag warning lamp.
- After replacing the air bag diagnosis sensor unit, confirm using CONSULT that the ECU discriminated number (identification number) or part number of the new replacement air bag diagnosis sensor unit matches the ECU discriminated number (identification number) or part number of the replaced (old) air bag diagnosis sensor unit.

NOTE:

If the ECU discriminated number or part number of the new replacement air bag diagnosis sensor unit differs from the ECU discriminated number or part number of the replaced air bag diagnosis sensor unit, reconfirm the parts information and verify that the correct air bag diagnosis sensor unit was installed.

A

B

C

D

E

F

G

SR

I

J

K

L

M

N

O

P

OCCUPANT CLASSIFICATION SYSTEM CONTROL UNIT

< REMOVAL AND INSTALLATION >

OCCUPANT CLASSIFICATION SYSTEM CONTROL UNIT

Removal and Installation

INFOID:000000011070222

The occupant classification control unit, occupant classification (pressure) sensor, and bladder are an integral part of the front passenger seat cushion and are replaced as an assembly. Refer to [SE-21, "Removal and Installation"](#) to remove the seat, and [SE-33, "Disassembly and Assembly"](#) to replace the seat cushion.

SATELLITE SENSOR

< REMOVAL AND INSTALLATION >

SATELLITE SENSOR

Removal and Installation - Side Air Bag (Satellite) Sensor

INFOID:000000011385493

EXPLODED VIEW

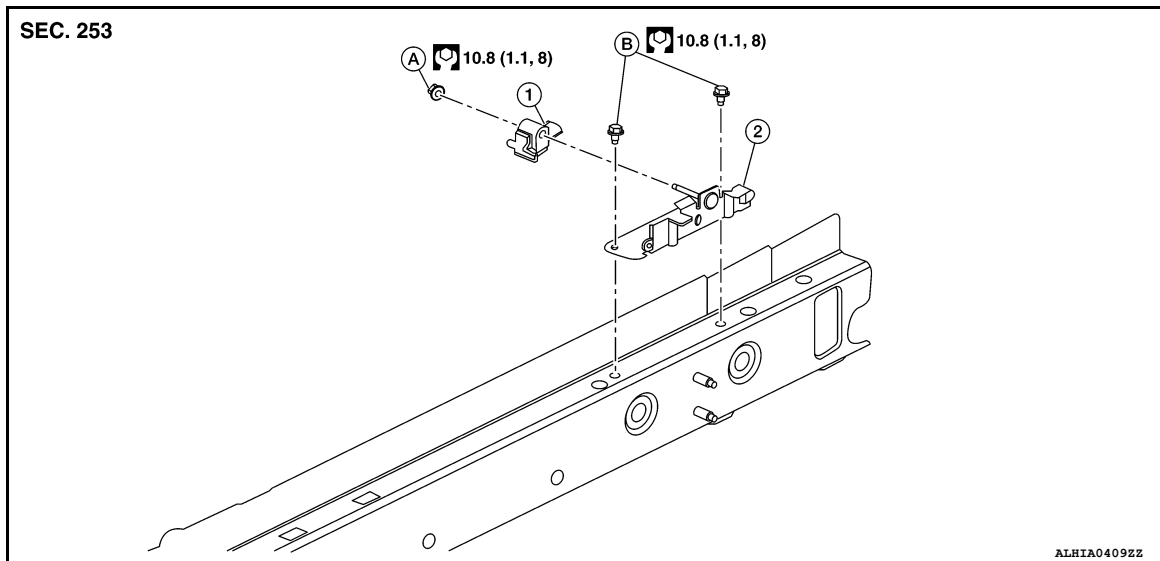

1. Side air bag (satellite) sensor 2. Side air bag (satellite) sensor bracket A. Nut
B. Bolts

REMOVAL

CAUTION:

- Before servicing the SRS, turn the ignition switch off, disconnect both battery terminals and wait at least three minutes.

1. Disconnect the negative and positive battery terminals, then wait at least three minutes. Refer to [PG-77, "Removal and Installation"](#).
2. Remove front door sill finisher and lift carpet.
3. Remove side air bag (satellite) sensor nut and bolts.
4. Disconnect the harness connector from side air bag (satellite) sensor .

INSTALLATION

Installation is in the reverse order of removal.

CAUTION:

- Do not reuse side air bag (satellite) sensor nut and bolts.
- Do not damage the harness connector during installation.
- After installation is complete, check that no system malfunction is detected causing the air bag warning lamp to illuminate.
- If a malfunction is indicated by the air bag warning lamp after repair or replacement of the malfunctioning parts, perform the SRS final check. Refer to [SRC-13, "SRS Operation Check"](#).

SATELLITE SENSOR

< REMOVAL AND INSTALLATION >

Removal and Installation - Front Door Satellite Sensor

INFOID:000000011385494

EXPLODED VIEW

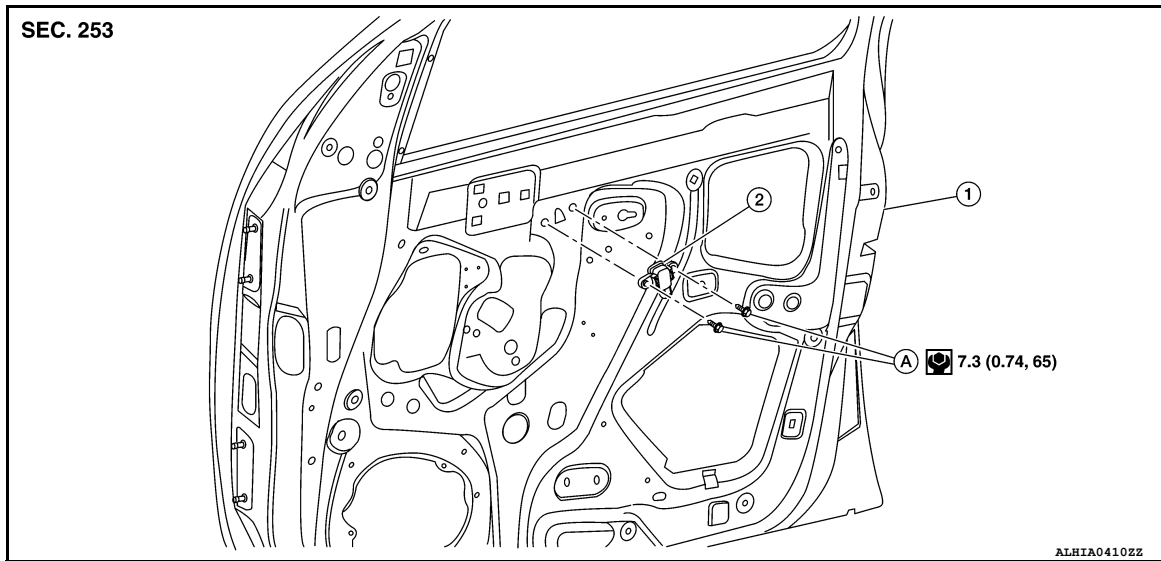

1. Front door

2. Front door satellite sensor

A. Bolts

REMOVAL

CAUTION:

- Before servicing the SRS, turn the ignition switch off, disconnect both battery terminals and wait at least three minutes.

1. Disconnect the negative and positive battery terminals, then wait at least three minutes. Refer to [PG-77, "Removal and Installation"](#).
2. Remove the front door finisher. Refer to [INT-14, "Removal and Installation"](#).
3. Remove the front door satellite sensor bolts.
4. Disconnect the harness connector from front door satellite sensor.
5. Remove the front door satellite sensor.

INSTALLATION

Installation is in the reverse order of removal.

CAUTION:

- Do not reuse front door satellite sensor bolts.
- Do not damage the harness connector during installation.
- After installation is complete, check that no system malfunction is detected causing the air bag warning lamp to illuminate.
- If a malfunction is indicated by the air bag warning lamp after repair or replacement of the malfunctioning parts, perform the SRS final check. Refer to [SRC-13, "SRS Operation Check"](#).