

# ENGINE LUBRICATION & COOLING SYSTEMS

## SECTION LC

GI  
MA  
EM

LC

EC

FE

CL

MT

AT

TF

PD

AX

SU

BR

ST

RS

BT

HA

SC

EL

IDX

## CONTENTS

<b>KA24DE</b>
<b>ENGINE LUBRICATION SYSTEM</b> .....3
Precautions .....3
SUPPLEMENTAL RESTRAINT SYSTEM (SRS)
"AIR BAG".....3
LIQUID GASKET APPLICATION PROCEDURE.....3
Preparation .....4
SPECIAL SERVICE TOOLS .....4
Lubrication Circuit.....5
Oil Pressure Check.....6
Oil Pump.....6
REMOVAL AND INSTALLATION.....6
REGULATOR VALVE INSPECTION .....7
OIL FILTER .....7
OIL PUMP INSPECTION .....7
Service Data and Specifications (SDS).....8
OIL PRESSURE CHECK .....8
REGULATOR VALVE .....8
OIL PUMP .....8
<b>ENGINE COOLING SYSTEM</b> .....9
Precautions .....9
SUPPLEMENTAL RESTRAINT SYSTEM (SRS)
"AIR BAG".....9
LIQUID GASKET APPLICATION PROCEDURE.....9
Preparation .....10
SPECIAL SERVICE TOOLS .....10
Cooling Circuit .....10
System Check.....11
CHECKING COOLING SYSTEM HOSES.....11
CHECKING RADIATOR.....11
CHECKING COOLING SYSTEM FOR LEAKS.....11
CHECKING RADIATOR CAP .....12
Water Pump.....12
REMOVAL.....12
INSPECTION.....12
INSTALLATION.....13
Thermostat.....13
REMOVAL.....13
INSPECTION.....13
INSTALLATION.....13

Radiator .....14	CL
REMOVAL AND INSTALLATION.....14	
COMPONENTS .....15	MT
INSPECTION.....15	
Cooling Fan (Crankshaft driven) .....16	
REMOVAL AND INSTALLATION.....16	AT
INSPECTION.....16	
Refilling Engine Coolant .....16	
Overheating Cause Analysis .....17	TF
Service Data and Specifications (SDS).....18	
THERMOSTAT .....18	PD
RADIATOR.....18	
<b>VG33E</b>	
<b>ENGINE LUBRICATION SYSTEM</b> .....19	AX
Precautions .....19	SU
SUPPLEMENTAL RESTRAINT SYSTEM (SRS)	
"AIR BAG".....19	
LIQUID GASKET APPLICATION PROCEDURE.....19	BR
Preparation .....20	
SPECIAL SERVICE TOOLS .....20	
Lubrication Circuit.....20	ST
Oil Pressure Check.....21	
Oil Pump.....21	
REMOVAL AND INSTALLATION.....21	RS
DISASSEMBLY AND ASSEMBLY.....22	
INSPECTION.....23	
REGULATOR VALVE INSPECTION .....23	BT
OIL FILTER .....23	
OIL FILTER BRACKET.....24	
Service Data and Specifications (SDS).....24	HA
OIL PRESSURE CHECK .....24	
REGULATOR VALVE .....24	
OIL PUMP.....24	SC
<b>ENGINE COOLING SYSTEM</b> .....25	
Precautions .....25	EL
SUPPLEMENTAL RESTRAINT SYSTEM (SRS)	
"AIR BAG".....25	
LIQUID GASKET APPLICATION PROCEDURE.....25	IDX
Preparation .....26	

# CONTENTS (Cont'd)

SPECIAL SERVICE TOOLS .....	26	Radiator .....	31
Cooling Circuit .....	26	REMOVAL AND INSTALLATION.....	31
System Check.....	26	COMPONENTS .....	31
CHECKING COOLING SYSTEM HOSES.....	27	INSPECTION.....	32
CHECKING RADIATOR CAP .....	27	Cooling Fan (Crankshaft driven) .....	32
CHECKING RADIATOR.....	27	REMOVAL AND INSTALLATION.....	32
CHECKING COOLING SYSTEM FOR LEAKS.....	27	INSPECTION.....	32
Water Pump.....	28	Refilling Engine Coolant .....	34
REMOVAL.....	28	Overheating Cause Analysis .....	34
INSPECTION.....	29	Service Data and Specifications (SDS).....	35
INSTALLATION.....	29	THERMOSTAT .....	35
Thermostat.....	29	RADIATOR.....	35
REMOVAL.....	29		
INSPECTION.....	30		
INSTALLATION.....	30		

## Precautions

### SUPPLEMENTAL RESTRAINT SYSTEM (SRS) "AIR BAG"

The Supplemental Restraint System "AIR BAG" and "SEAT BELT PRE-TENSIONER", used along with a seat belt, helps to reduce the risk or severity of injury to the driver and front passenger in certain types collisions. The Supplemental Restraint System consists of air bag modules (located in the center of the steering wheel), a front passenger air bag module (located on the instrument panel on the passenger side), seat belt pre-tensioners, a diagnosis sensor unit, a crash zone sensor (4WD models), a warning lamp, wiring harness, and spiral cable.

Information necessary to service the system safely is included in the **RS section** of this Service Manual.

#### WARNING:

- To avoid rendering the SRS inoperative, which could increase the risk of personal injury or death in the event of a collision which would result in air bag inflation, all maintenance should be performed by an authorized NISSAN dealer.
- Improper maintenance, including incorrect removal and installation of the SRS, can lead to personal injury caused by unintentional activation of the system. For removal of Spiral Cable and Air Bag Module, refer to *RS-16*.
- Do not use electrical test equipment on any circuit related to the SRS unless instructed to in this Service Manual. Spiral cable and wiring harnesses (except "SEAT BEAT PRE-TENSIONER") covered with yellow insulation either just before the harness connectors or on the complete harness, are related to the SRS.

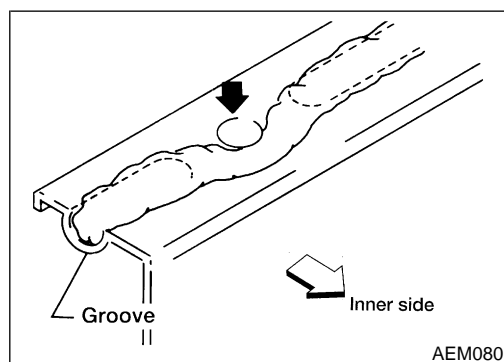
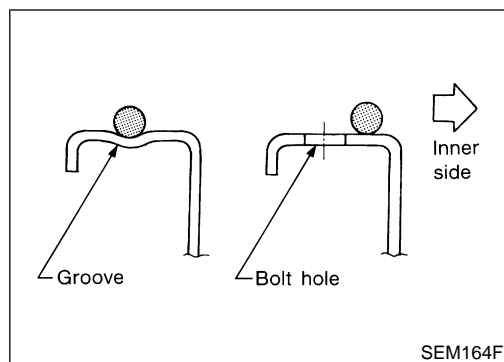

### LIQUID GASKET APPLICATION PROCEDURE

1. Use a scraper to remove all traces of old liquid gasket from mating surfaces and grooves. Also, completely clean any oil from these areas.
2. Apply a continuous bead of liquid gasket to mating surfaces. (Use Genuine RTV Silicone Sealant Part No. 999 MP-A7007 or equivalent.)
  - For oil pan, be sure liquid gasket diameter is 3.5 to 4.5 mm (0.138 to 0.177 in).
  - For areas except oil pan, be sure liquid gasket diameter is 2.0 to 3.0 mm (0.079 to 0.118 in).
3. Apply liquid gasket around the inner side of bolt holes (unless otherwise specified).
4. Assembly should be done within 5 minutes after coating.
5. Wait at least 30 minutes before refilling engine oil and engine coolant.

## Preparation

### SPECIAL SERVICE TOOLS

=NGLC0068

The actual shapes of Kent-Moore tools may differ from those of special service tools illustrated here.

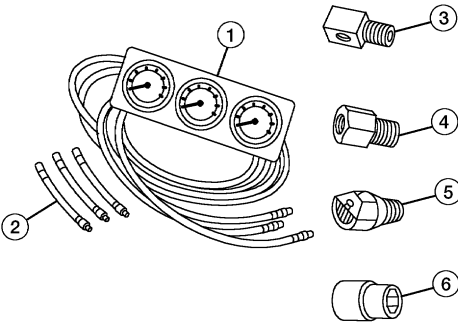
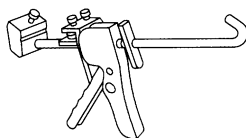
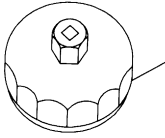
Tool number (Kent-Moore No.) Tool name	Description	
(J34301-C) Oil pressure gauge set 1: (J34301-1) Oil pressure gauge 2: (J34301-2) Hoses 3: (J34298) Adapter 4: (J34282-1) Adapter 5: (790-301-1230-A) 60° adapter 6: (J34301-15) Square socket	 <p style="text-align: left; margin-top: 10px;">AAT896</p>	Measuring oil pressure <b>Maximum measuring range:</b> <b>1,379 kPa (14 kg/cm<sup>2</sup>, 200 psi)</b>
WS39930000 ( — ) Tube presser	 <p style="text-align: left; margin-top: 10px;">NT052</p>	Pressing the tube of liquid gasket
KV10115801 (J38956) Oil filter wrench	 <p style="text-align: left; margin-top: 10px;">14 faces, Inner span: 64.3 mm (2.531 in) (Face to opposite face)</p> <p style="text-align: left; margin-top: 10px;">NT362</p>	Removing oil filter

## Lubrication Circuit

NGLC0069

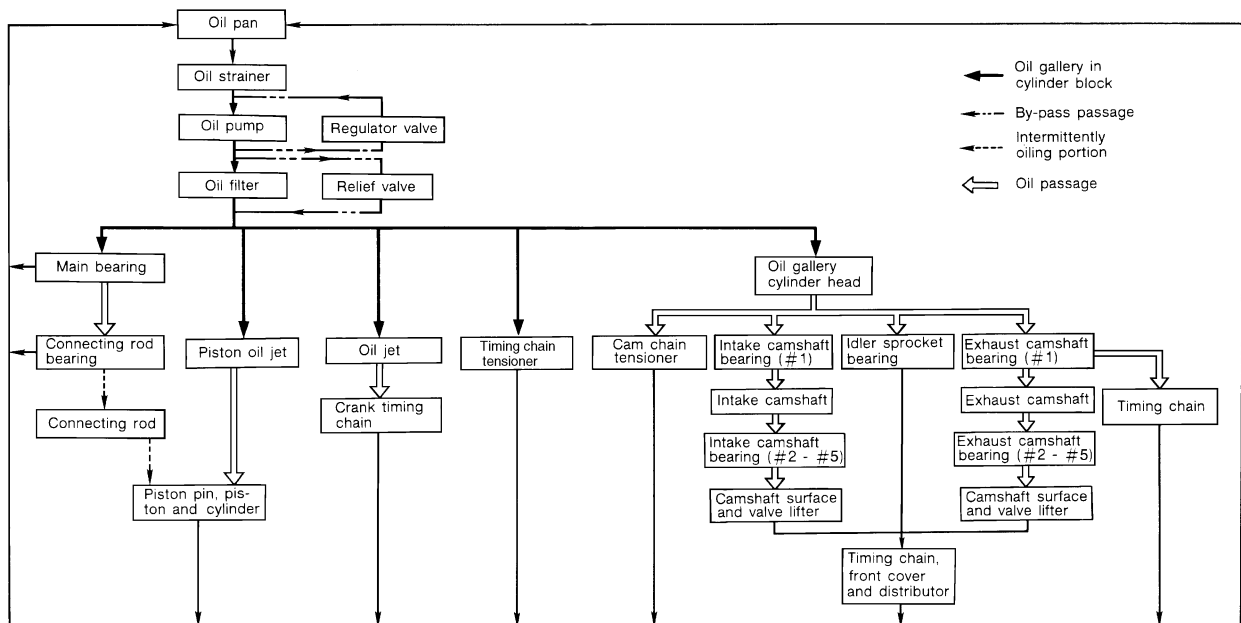
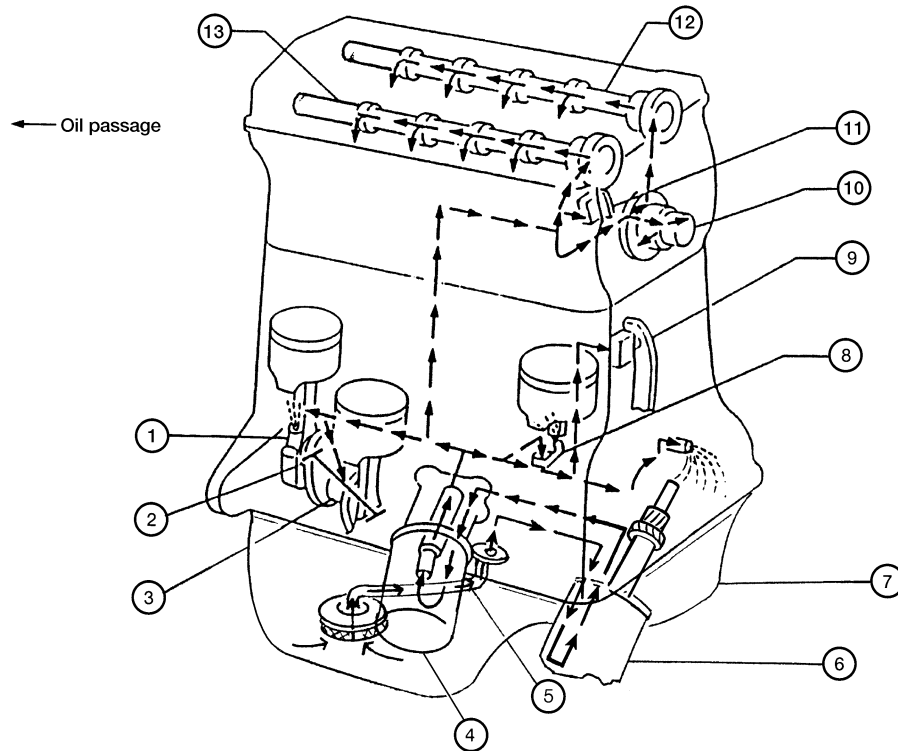

ALC116

- |                           |                           |                                  |
|---------------------------|---------------------------|----------------------------------|
| 1. Connecting rod         | 6. Oil pump               | 10. Idler sprocket               |
| 2. Connecting rod bearing | 7. Oil pan                | 11. Upper timing chain tensioner |
| 3. Main bearing           | 8. Piston oil jet         | 12. Exhaust camshaft             |
| 4. Oil filter             | 9. Timing chain tensioner | 13. Intake camshaft              |
| 5. Oil strainer           |                           |                                  |

GI

MA

EM

**LC**

EC

FE

CL

MT

AT

TF

PD

AX

SU

BR

ST

RS

BT

HA

SC

EL

IDX

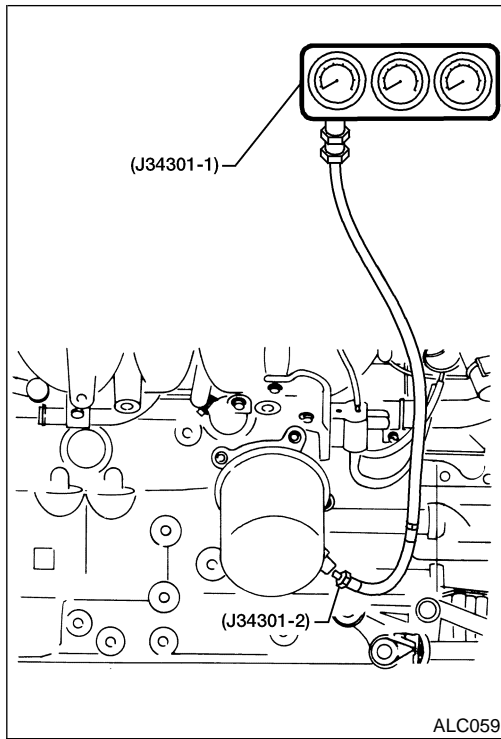

## Oil Pressure Check

NGLC0070

### WARNING:

- Be careful not to burn yourself, as the engine and oil may be hot.
- For M/T models, put gearshift lever in Neutral “N” position. For A/T models, put selector lever in Park “P” position.

1. Check oil level.
2. Remove oil pressure switch.
3. Install pressure gauge.
4. Start engine and warm it up to normal operating temperature.
5. Check oil pressure with engine running under no-load.

Engine speed	Approximate discharge pressure
Idle speed	More than 78 kPa (0.8 kg/cm <sup>2</sup> , 11 psi)
3,000 rpm	412 - 481 kPa (4.2 - 4.9 kg/cm <sup>2</sup> , 60 - 70 psi)

- If difference is extreme, check oil passage and oil pump for oil leaks.

6. Install oil pressure switch with sealant.

: 12.25 – 17.15 N·m (1.3 – 1.7 kg·m, 9 – 12 ft·lb)

## Oil Pump

### REMOVAL AND INSTALLATION

NGLC0071

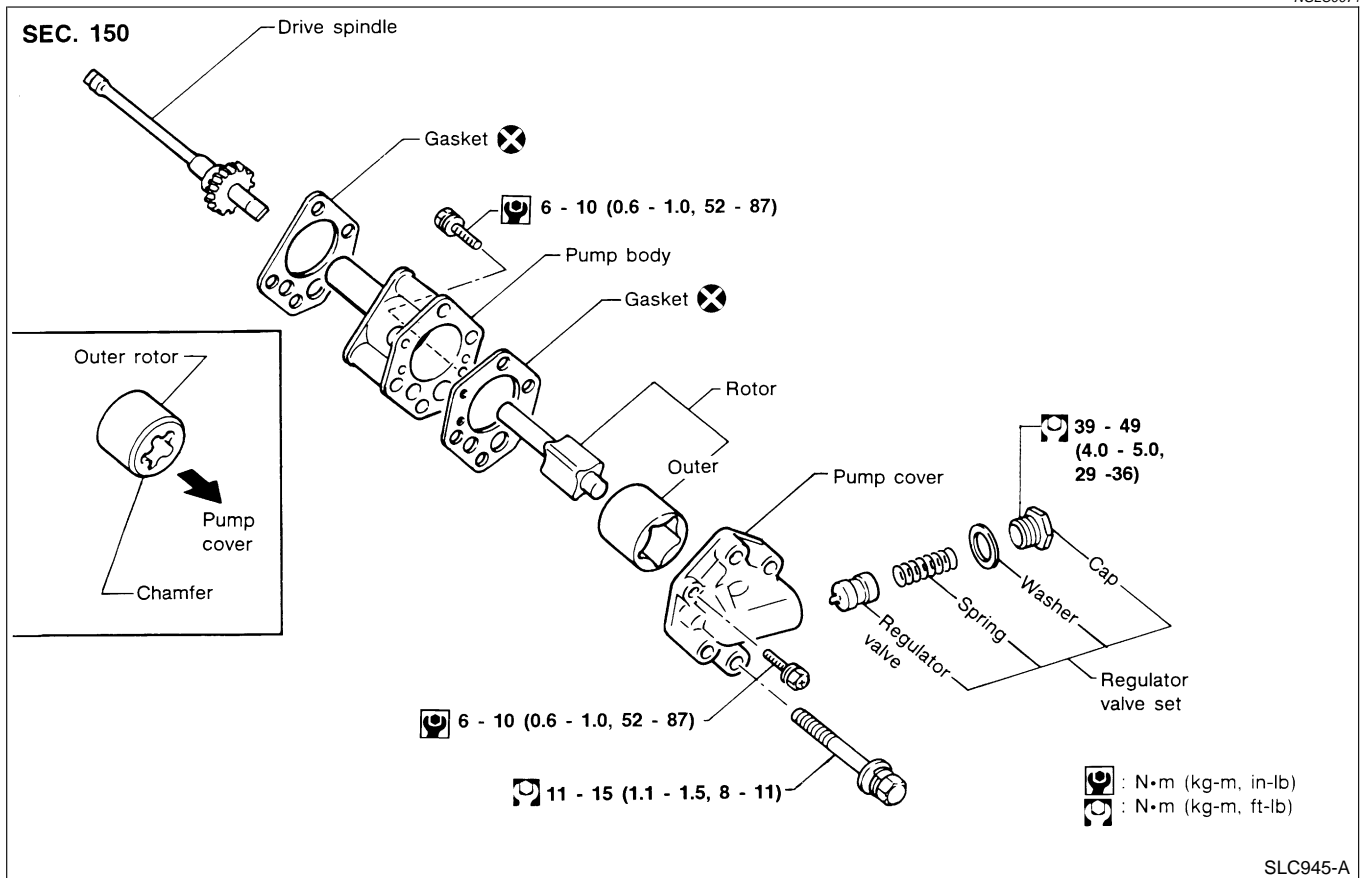

SLC945-A

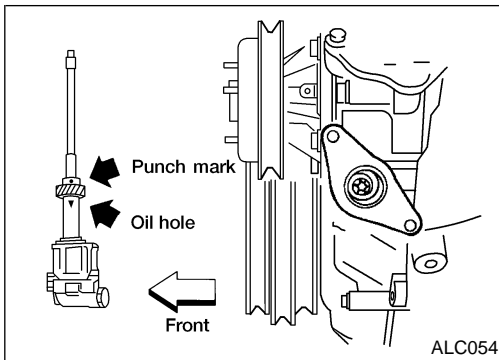

- Always replace with new oil seal and gasket.
- When removing oil pump, turn crankshaft so that No. 1 piston is at TDC on its compression stroke.
- When installing oil pump, apply engine oil to gears, then align punchmark on drive spindle and oil hole on oil pump.

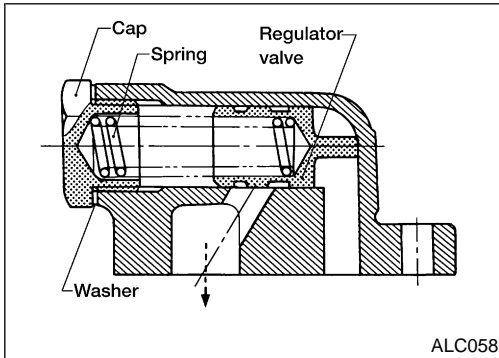

## REGULATOR VALVE INSPECTION

NGLC0072

1. Visually inspect components for wear and damage.
  2. Check oil pressure regulator valve sliding surface and valve spring.
  3. Coat regulator valve with engine oil. Check that it falls smoothly into the valve hole by its own weight.
- Replace regulator valve set or oil pump assembly, if damaged.

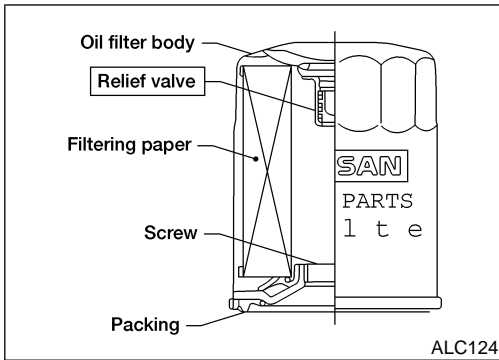

## OIL FILTER

NGLC0073

The oil filter is a small, full-flow cartridge type and is provided with a relief valve.

- The new and previous oil filter designs differ from each other and are not interchangeable.
- Use Tool KV10115801 (J38956) for removing oil filter.

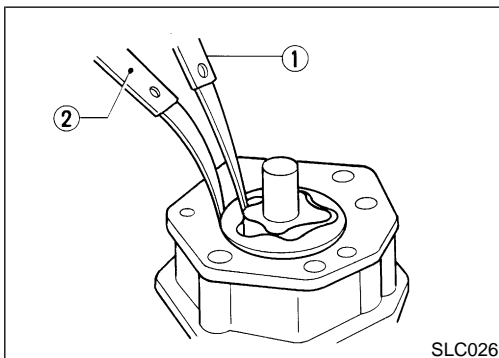

## OIL PUMP INSPECTION

NGLC0074

Using a feeler gauge, check the following clearances.

**Standard clearance:**

Unit: mm (in)

Rotor tip clearance 1	Less than 0.12 (0.0047)
Outer rotor to body clearance 2	0.15 - 0.21 (0.0059 - 0.0083)
Side clearance (with gasket) 3	0.04 - 0.100 (0.0016 - 0.0039)

- If the tip clearance (1) exceeds the limit, replace gear set.
- If body to gear clearances (2, 3) exceed the limit, replace oil pump assembly.

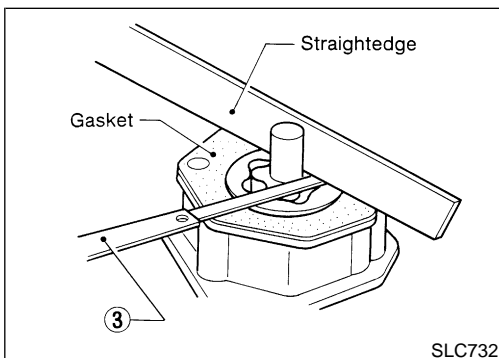

# ENGINE LUBRICATION SYSTEM

KA24DE

Service Data and Specifications (SDS)

## Service Data and Specifications (SDS)

### OIL PRESSURE CHECK

NGLC0075

Engine speed	Approximate discharge pressure
Idle speed	More than 78 kPa (0.8 kg/cm <sup>2</sup> , 11 psi)
3,000 rpm	412 - 481 kPa (4.2 - 4.9 kg/cm <sup>2</sup> , 60 - 70 psi)

### REGULATOR VALVE

NGLC0131  
Unit: mm (in)

Regulator valve to oil pump cover clearance	0.040 - 0.097 (0.0016 - 0.0038)
---	---------------------------------

### OIL PUMP

NGLC0076  
Unit: mm (in)

Rotor tip clearance	Less than 0.12 (0.0047)
Outer rotor to body clearance	0.15 - 0.21 (0.0059 - 0.0083)
Side clearance (with gasket)	0.04 - 0.100 (0.0016 - 0.0039)



## Precautions

### SUPPLEMENTAL RESTRAINT SYSTEM (SRS) "AIR BAG"

NGLC0133

The Supplemental Restraint System "AIR BAG" and "SEAT BELT PRE-TENSIONER", used along with a seat belt, helps to reduce the risk or severity of injury to the driver and front passenger in certain types collisions. The Supplemental Restraint System consists of air bag modules (located in the center of the steering wheel), a front passenger air bag module (located on the instrument panel on the passenger side), seat belt pre-tensioners, a diagnosis sensor unit, a crash zone sensor (4WD models), a warning lamp, wiring harness, and spiral cable.

Information necessary to service the system safely is included in the **RS section** of this Service Manual.

#### WARNING:

- To avoid rendering the SRS inoperative, which could increase the risk of personal injury or death in the event of a collision which would result in air bag inflation, all maintenance should be performed by an authorized NISSAN dealer.
- Improper maintenance, including incorrect removal and installation of the SRS, can lead to personal injury caused by unintentional activation of the system. For removal of Spiral Cable and Air Bag Module, refer to *RS-16*.
- Do not use electrical test equipment on any circuit related to the SRS unless instructed to in this Service Manual. Spiral cable and wiring harnesses (except "SEAT BEAT PRE-TENSIONER") covered with yellow insulation either just before the harness connectors or on the complete harness, are related to the SRS.

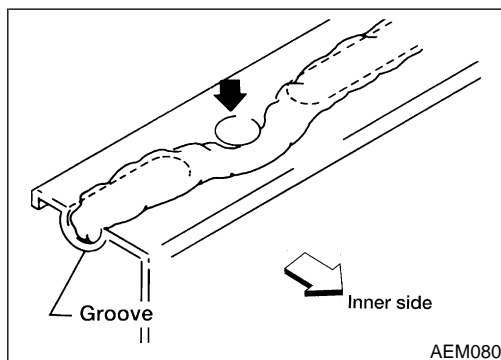
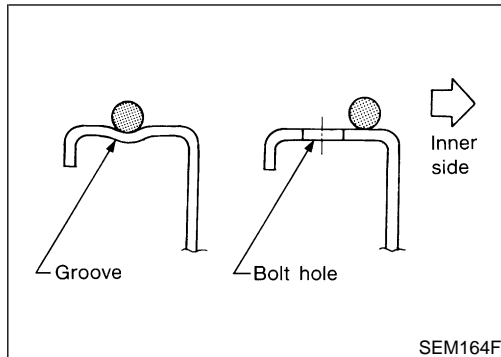

### LIQUID GASKET APPLICATION PROCEDURE

NGLC0109

1. Use a scraper to remove all traces of old liquid gasket from mating surfaces and grooves. Also, completely clean any oil from these areas.
2. Apply a continuous bead of liquid gasket to mating surfaces. (Use Genuine RTV Silicone Sealant Part No. 999 MP-A7007 or equivalent.)
  - For oil pan, be sure liquid gasket diameter is 3.5 to 4.5 mm (0.138 to 0.177 in).
  - For areas except oil pan, be sure liquid gasket diameter is 2.0 to 3.0 mm (0.079 to 0.118 in).
3. Apply liquid gasket around the inner side of bolt holes (unless otherwise specified).
4. Assembly should be done within 5 minutes after coating.
5. Wait at least 30 minutes before refilling engine oil and engine coolant.

## Preparation

### SPECIAL SERVICE TOOLS

=NGLC0110

The actual shapes of Kent-Moore tools may differ from those of special service tools illustrated here.

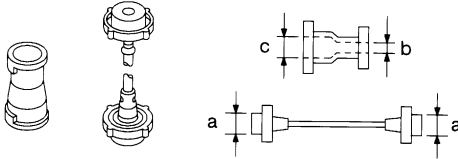
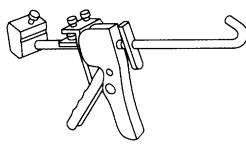
Tool number (Kent-Moore No.) Tool name	Description	
EG17650301 (J33984-A) Radiator cap tester adapter		Adapting radiator cap tester to radiator filler neck <b>a: 28 (1.10) dia.</b> <b>b: 31.4 (1.236) dia.</b> <b>c: 41.3 (1.626) dia.</b> Unit: mm (in)
WS39930000 ( — ) Tube presser		Pressing the tube of liquid gasket

## Cooling Circuit

NGLC0111

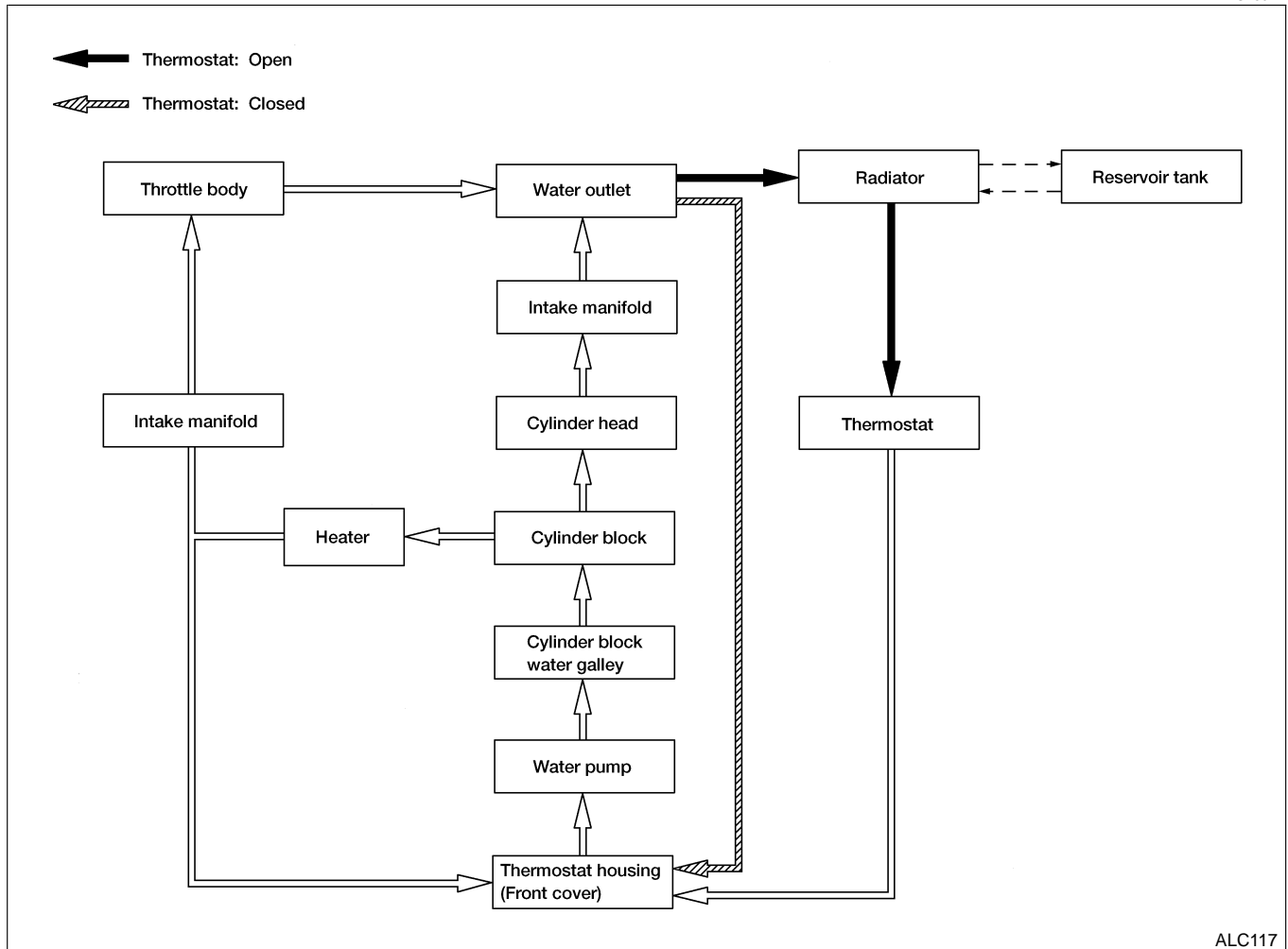

ALC117

## System Check

NGLC0112

### WARNING:

Never remove the radiator cap when the engine is hot. Serious burns could occur from high pressure coolant escaping from the radiator.

Wrap a thick cloth around the radiator cap. Slowly turn it a quarter turn to allow built-up pressure to escape. Carefully remove the radiator cap by turning it all the way.

## CHECKING COOLING SYSTEM HOSES

NGLC0112S01

Check hoses for the following:

- Improper attachment
- Leaks
- Cracks
- Damage
- Chafing
- Deterioration

## CHECKING RADIATOR

NGLC0112S02

Check radiator for mud or clogging. If necessary, clean radiator as follows.

- Be careful not to bend or damage the radiator fins.
  - When radiator is cleaned without removal, remove all surrounding parts such as cooling fan, radiator shroud and horns.
  - Tape the harness connectors to prevent water from entering.
1. Apply water by hose to the back side of the radiator core vertically downward.
  2. Apply water again to all radiator core surfaces once per minute.
  3. Stop washing when stains no longer flow out from the radiator.
  4. Blow air into the back side of radiator core vertically downward.
- Use compressed air lower than 490 kPa (5 kg/cm<sup>2</sup>, 71 psi) and keep distance more than 30 cm (11.8 in).
5. Blow air again into all the radiator core surfaces once per minute until no water sprays out.

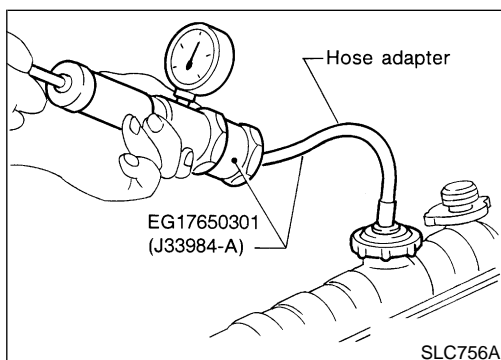

## CHECKING COOLING SYSTEM FOR LEAKS

NGLC0112S03

To check for leakage, apply pressure to the cooling system with a radiator cap tester.

**Testing pressure:**

**157 kPa (1.6 kg/cm<sup>2</sup>, 23 psi)**

### CAUTION:

Higher pressure than specified may cause radiator damage.

## System Check (Cont'd)

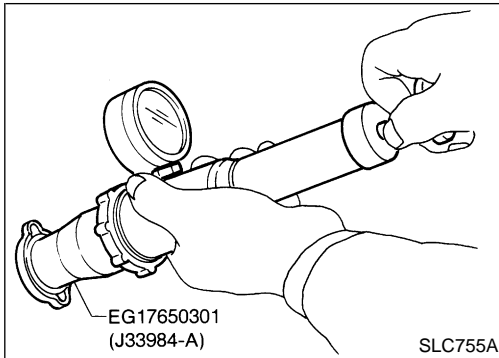
**CHECKING RADIATOR CAP**

NGLC0112S04

To check radiator cap, apply pressure to radiator cap with a radiator cap tester.

**Radiator cap relief pressure:****Standard**

78 - 98 kPa (0.8 - 1.0 kg/cm<sup>2</sup>, 11 - 14 psi)

**Limit**

59 - 98 kPa (0.6 - 1.0 kg/cm<sup>2</sup>, 9 - 14 psi)

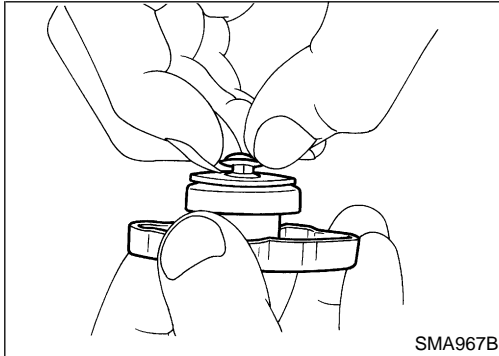

Pull the negative pressure valve to open it. Check that it closes completely when released.

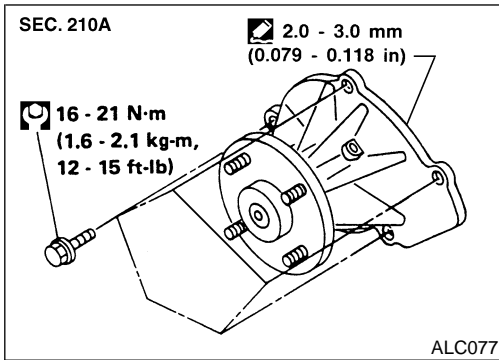
**Water Pump****REMOVAL**

NGLC0113

**CAUTION:**

- When removing water pump assembly, be careful not to get coolant on drive belts.
  - Water pump cannot be disassembled and should be replaced as a unit.
  - After installing water pump, connect hose and clamp securely. Check for leaks using radiator cap tester.
1. Drain coolant from engine. Refer to **MA-18** ("Changing Engine Coolant", "ENGINE MAINTENANCE").
  2. Remove fan coupling with fan.
  3. Remove power steering pump drive belt, generator drive belt and A/C compressor drive belt.
  4. Remove water pump.

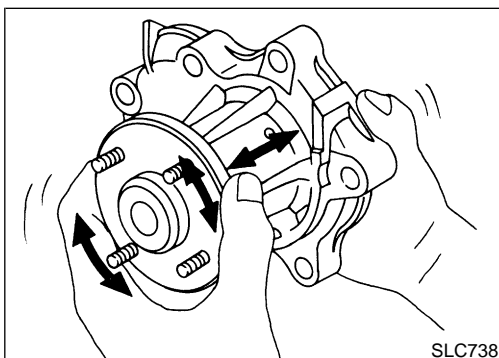
**INSPECTION**

NGLC0114

- Check body assembly for rust or corrosion.
- Check for rough operation due to excessive end play.

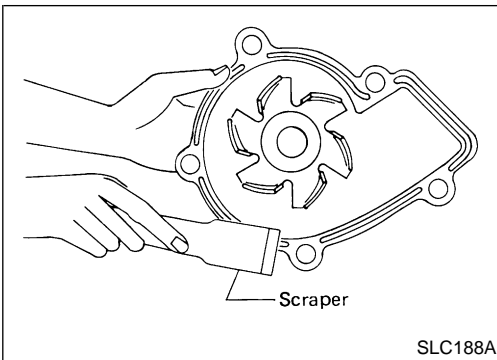

## INSTALLATION

NGLC0115

1. Use a scraper to remove liquid gasket from water pump.
  - Also remove traces of liquid gasket from mating surface of cylinder block.

GI

MA

EM

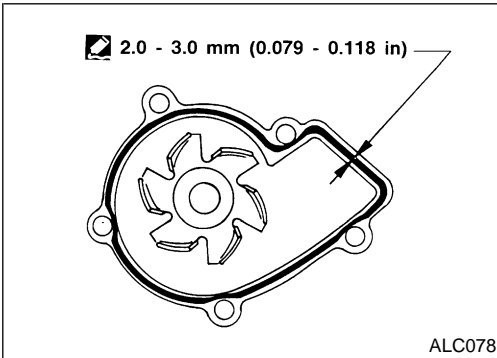
**LC**

2. Apply a continuous bead of liquid gasket to mating surface of water pump.
  - Use Genuine RTV Silicone Sealant Part No. 999 MP-A7007 or equivalent.

EC

When filling radiator with coolant, refer to **MA-18** ("Changing Engine Coolant", "ENGINE MAINTENANCE").  
When installing drive belts, refer to **MA-17** ("Checking Drive Belts").

FE

CL

MT

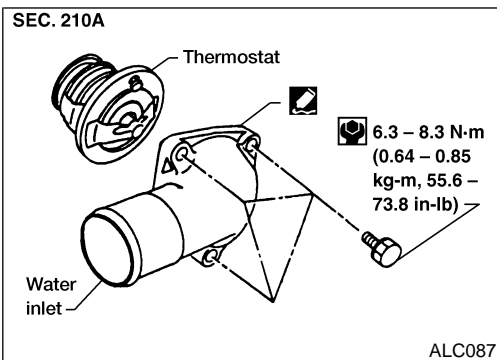

## Thermostat

### REMOVAL

NGLC0116

- Be careful not to spill coolant over engine compartment. Use a rag to absorb coolant.
1. Drain coolant from engine. Refer to **MA-18** ("Changing Engine Coolant", "ENGINE MAINTENANCE").
  2. Remove air cleaner and air duct assembly.
  3. Remove water hose from water inlet housing.
  4. Remove water inlet housing, then take out thermostat.

AT

TF

PD

AX

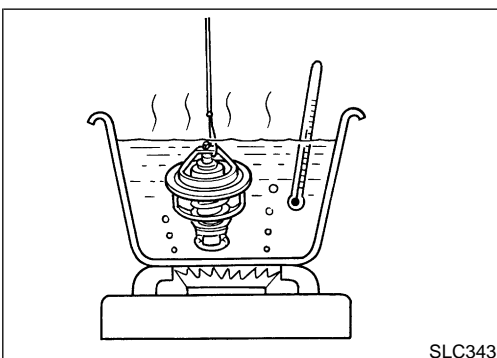

## INSPECTION

NGLC0117

1. Check valve seating condition at normal room temperature. It should seat tightly.
2. Check valve opening temperature and valve lift.

SU

BR

Valve opening temperature	76.5°C (170°F)
Valve lift	More than 8 mm/90°C (0.31 in/194°F)

ST

3. Check if valve closes at 5°C (9°F) below valve opening temperature.

RS

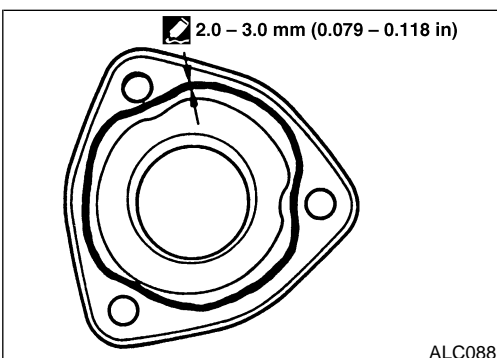

## INSTALLATION

NGLC0118

1. Use a scraper to remove old liquid gasket from water inlet.
  - Also remove traces of liquid gasket from mating surface of front cover.
2. Apply a continuous bead of liquid gasket to mating surface of water inlet.
  - Use Genuine RTV Silicone Sealant Part No. 999 MP-A7007 or equivalent.

BT

HA

SC

EL

IDX

## Thermostat (Cont'd)

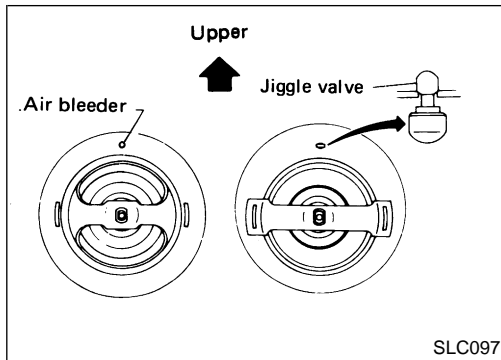

3. Install thermostat with jiggle valve or air bleeder at upper side.
  4. Install water inlet housing.
  5. Install water hose to water inlet housing.
  6. Install air cleaner and air duct assembly.
  7. Refill engine coolant. Refer to **MA-18** ("Changing Engine Coolant", "ENGINE MAINTENANCE").
- **After installation, run engine for a few minutes and check for leaks.**

**Radiator****REMOVAL AND INSTALLATION**

NGLC0119

1. Remove under cover.
  2. Drain coolant from radiator. Refer to **MA-18** ("Changing Engine Coolant", "ENGINE MAINTENANCE").
  3. Disconnect upper and lower radiator hoses.
  4. Remove air cleaner and air duct assembly.
  5. Remove lower radiator shroud.
  6. Remove radiator shroud.
  7. Remove A/T oil cooler hoses (A/T models only).
  8. Disconnect coolant reservoir hose.
  9. Remove radiator.
  10. After replacing radiator, install all parts in reverse order of removal.
  11. Refill engine coolant. Refer to **MA-18** ("Changing Engine Coolant", "ENGINE MAINTENANCE").
- **After installation, run engine for a few minutes, and check for leaks.**

## COMPONENTS

NGLC0120

SEC. 214

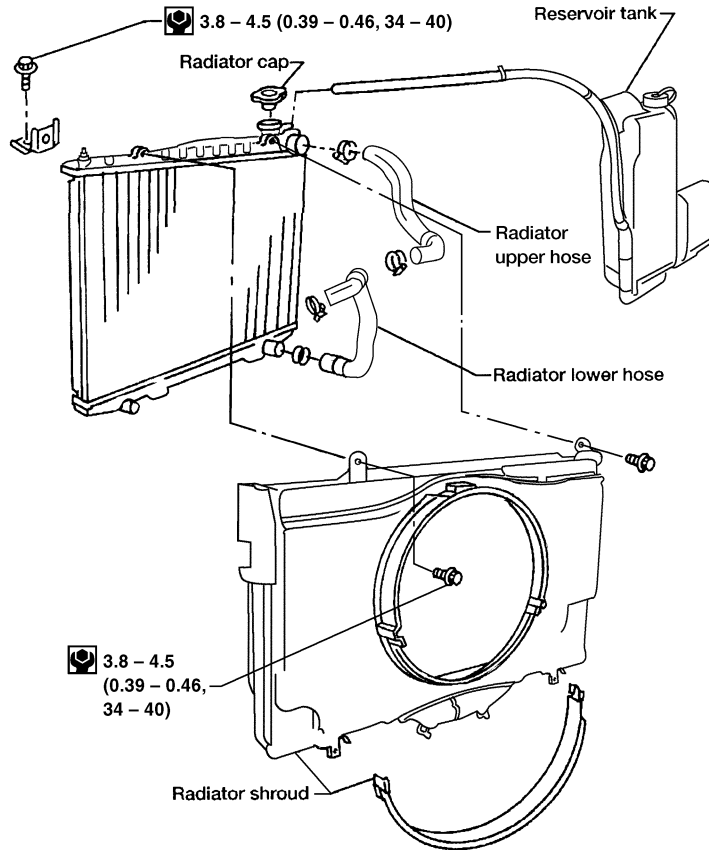

: N·m (kg·m, in·lb)

ALC118

GI

MA

EM

**LC**

EC

FE

CL

MT

AT

TF

PD

AX

SU

NGLC0130

BR

ST

RS

BT

HA

SC

EL

IDX

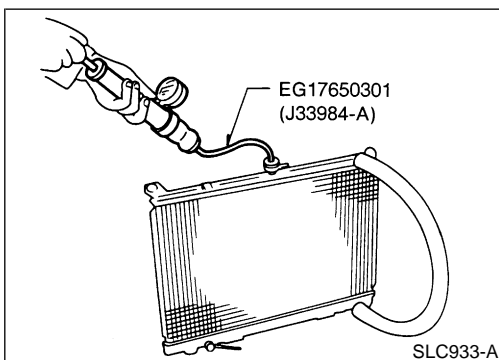

SLC933-A

### INSPECTION

1. Apply pressure with Tool.

**Specified pressure value:**  
 157 kPa (1.6 kg/cm<sup>2</sup>, 23 psi)

**WARNING:**

To prevent the risk of the hose coming undone while under pressure, securely fasten it down with a hose clamp. Attach a hose to the oil cooler as well. (A/T model only)

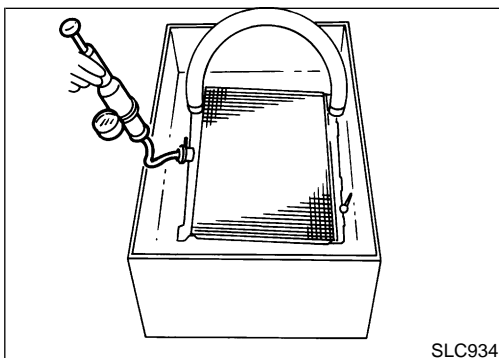

SLC934

2. Check for leakage.

## Cooling Fan (Crankshaft driven)

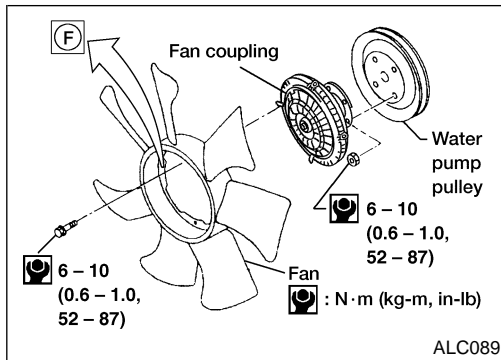

## Cooling Fan (Crankshaft driven)

### REMOVAL AND INSTALLATION

- Do not release the drive belt tension by removing the fan/water pump pulley. NGLC0121
- Fan coupling cannot be disassembled and should be replaced as a unit. If front mark **F** is present, install fan so that side marked **F** faces the front.
- Install the drive belt only after the fan and fan coupling to water pump flange bolts/nuts have been properly torqued.
- Proper alignment of these components is essential. Improper alignment will cause them to wobble and may eventually cause the fan to separate from the water pump, causing extensive damage.

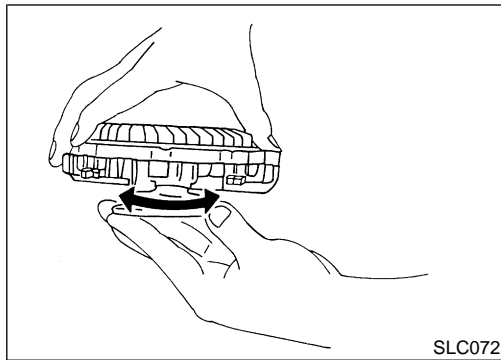

### INSPECTION

Check fan coupling for rough operation, silicon oil leakage and bent bimetal. NGLC0122

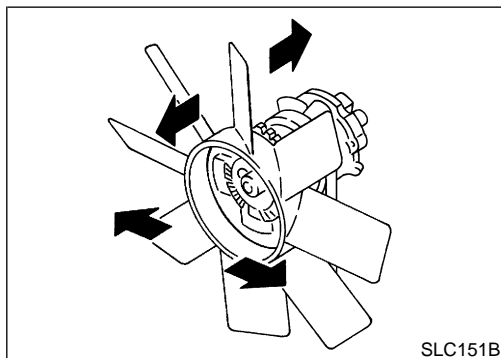

After assembly, verify the fan does not wobble or flap while the engine is running.

### **WARNING:**

- **When the engine is running, keep hands and clothing away from moving parts such as drive belts and fan.**

## Refilling Engine Coolant

For details on refilling engine coolant, refer to **MA-18** ("Changing Engine Coolant", "ENGINE MAINTENANCE"). NGLC0123



# ENGINE COOLING SYSTEM

**KA24DE**

Overheating Cause Analysis

## Overheating Cause Analysis

=NGLC0125

		Symptom	Check items			
Cooling system parts malfunction	Poor heat transfer	Water pump malfunction	Worn or loose drive belt	—	GI	
		Thermostat stuck closed	—		MA	
		Damaged fins	Dust contamination or paper clogging		—	EM
			Mechanical damage			LC
	Reduced air flow	Clogged radiator cooling tube	Excess foreign material (rust, dirt, sand, etc.)	—	EC	
		Fan coupling does not operate	—		FE	
		High resistance to fan rotation			CL	
	Damaged fan blades	—		—	MT	
	Damaged radiator shroud	—	—	—	AT	
	Improper coolant mixture ratio	—	—	—	TF	
	Poor coolant quality	—	—	—	PD	
	Insufficient coolant	Coolant leaks	Cooling hose	Loose clamp	—	AX
				Cracked hose		SU
			Water pump	Poor sealing	—	BR
				Radiator cap		Loose
Radiator			Poor sealing	—	RS	
			O-ring for damage, deterioration or improper fitting		BT	
	Cracked radiator tank	HA				
Reservoir tank	Cracked radiator core	—	SC			
	Cracked reservoir tank		EL			
Overflowing reservoir tank	Exhaust gas leaks into cooling system	Cylinder head deterioration	—	IDX		
		Cylinder head gasket deterioration				

# ENGINE COOLING SYSTEM

KA24DE

## Overheating Cause Analysis (Cont'd)

	Symptom		Check items		
Except cooling system parts malfunction	—	Overload on engine	Abusive driving	High engine rpm under no-load	
				Driving in low gear for extended time	
				Driving at extremely high speed	
			Powertrain system malfunction	—	Installed improper size wheels and tires
					Dragging brakes
					Improper ignition timing
	Blocked or restricted air flow	Blocked bumper	—	—	
		Blocked radiator grille	Installed car brassiere		
			Mud contamination or paper clogging		
		Blocked radiator	—		
Blocked condenser		—			
Installed large fog lamp	—				

## Service Data and Specifications (SDS)

### THERMOSTAT

NGLC0126

Valve opening temperature	76.5°C (170°F)
Valve lift	More than 8 mm/90°C (0.31 in/194°F)

### RADIATOR

Unit: kPa (kg/cm<sup>2</sup>, psi)  
NGLC0127

Cap relief pressure	Standard	78 - 98 (0.8 - 1.0, 11 - 14)
	Limit	59 - 98 (0.6 - 1.0, 9 - 14)
Leakage test pressure		157 (1.6, 23)

## Precautions

## SUPPLEMENTAL RESTRAINT SYSTEM (SRS) "AIR BAG"

NGLC0134

The Supplemental Restraint System "AIR BAG" and "SEAT BELT PRE-TENSIONER", used along with a seat belt, helps to reduce the risk or severity of injury to the driver and front passenger in certain types collisions. The Supplemental Restraint System consists of air bag modules (located in the center of the steering wheel), a front passenger air bag module (located on the instrument panel on the passenger side), seat belt pre-tensioners, a diagnosis sensor unit, a crash zone sensor (4WD models), a warning lamp, wiring harness, and spiral cable.

Information necessary to service the system safely is included in the **RS section** of this Service Manual.

**WARNING:**

- To avoid rendering the SRS inoperative, which could increase the risk of personal injury or death in the event of a collision which would result in air bag inflation, all maintenance should be performed by an authorized NISSAN dealer.
- Improper maintenance, including incorrect removal and installation of the SRS, can lead to personal injury caused by unintentional activation of the system. For removal of Spiral Cable and Air Bag Module, refer to *RS-16*.
- Do not use electrical test equipment on any circuit related to the SRS unless instructed to in this Service Manual. Spiral cable and wiring harnesses (except "SEAT BEAT PRE-TENSIONER") covered with yellow insulation either just before the harness connectors or on the complete harness, are related to the SRS.

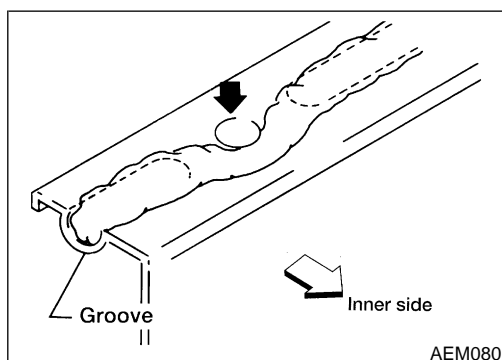
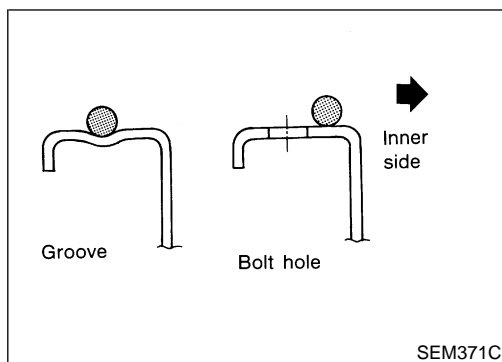

## LIQUID GASKET APPLICATION PROCEDURE

NGLC0001

1. Use a scraper to remove all traces of old liquid gasket from mating surface and grooves. Also, completely clean any oil from these areas.
2. Apply a continuous bead of liquid gasket to mating surfaces. (Use Genuine RTV silicone sealant Part No. 999MP-A7007 or equivalent.)
  - Be sure liquid gasket is 3.5 to 4.5 mm (0.138 to 0.177 in) dia. (for oil pan).
  - Be sure liquid gasket is 2.0 to 3.0 mm (0.079 to 0.118 in) dia. (in areas except oil pan).
3. Apply liquid gasket around the inner side of bolt holes (unless otherwise specified).
4. Assembly should be done within 5 minutes after coating.
5. Wait at least 30 minutes before refilling engine oil and engine coolant.

## Preparation

### SPECIAL SERVICE TOOLS

The actual shapes of Kent-Moore tools may differ from those of special service tools illustrated here. =NGLC0002

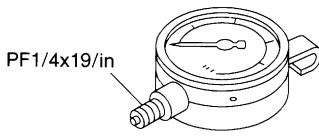
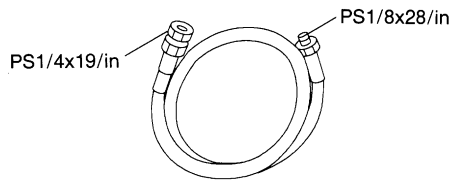
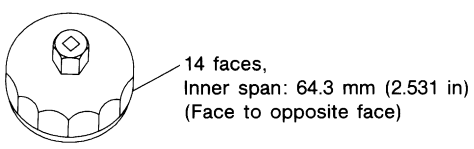
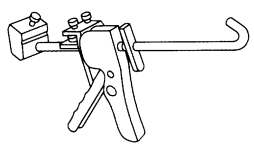
Tool number (Kent-Moore No.) Tool name	Description	
ST25051001 (J25695-1) Oil pressure gauge	 <p>PF1/4x19/in</p>	Measuring oil pressure <b>Maximum measuring range:</b> <b>2,452 kPa (25 kg/cm<sup>2</sup>, 356 psi)</b>
NT558		
ST25052000 (J25695-2) Hose	 <p>PS1/4x19/in      PS1/8x28/in</p>	Adapting oil pressure gauge to cylinder block
NT559		
KV10115801 (J38956) Oil filter wrench	 <p>14 faces, Inner span: 64.3 mm (2.531 in) (Face to opposite face)</p>	Removing oil filter
NT362		
WS39930000 (      —      ) Tube presser		Pressing the tube of liquid gasket
NT052		

## Lubrication Circuit

NGLC0003

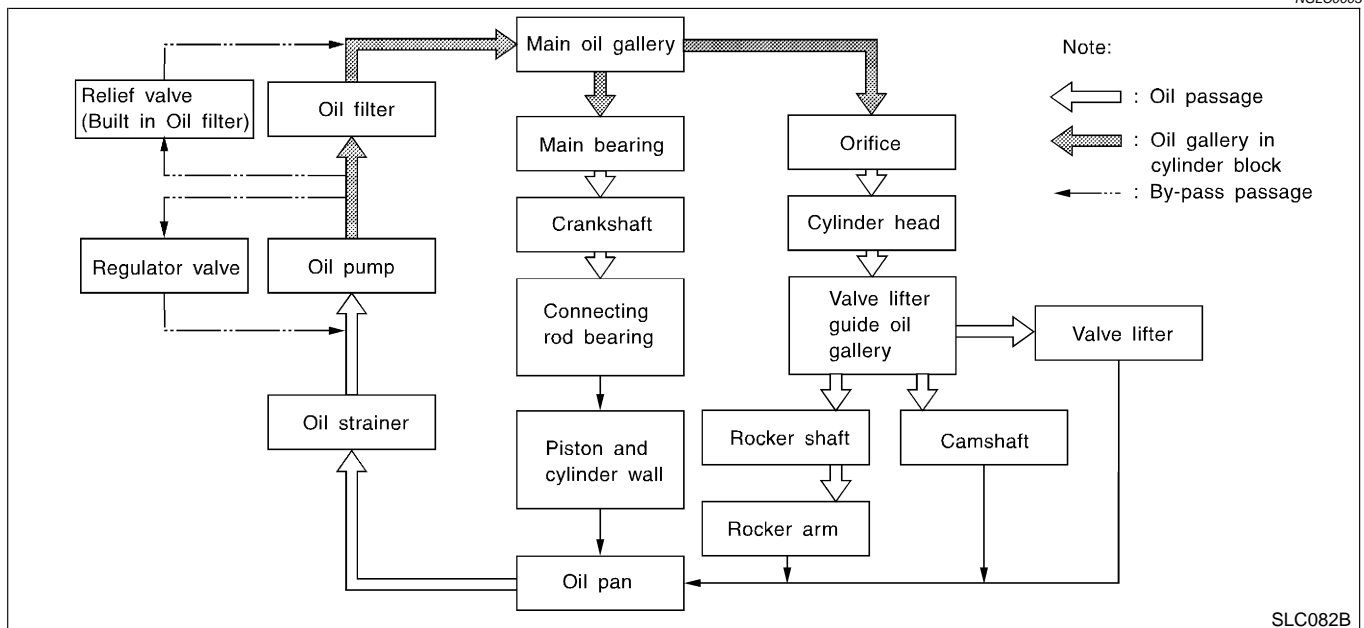

SLC082B

NGLC0004

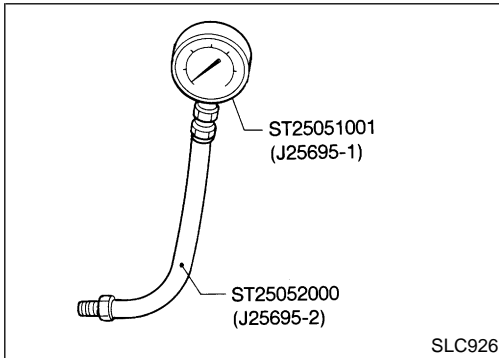
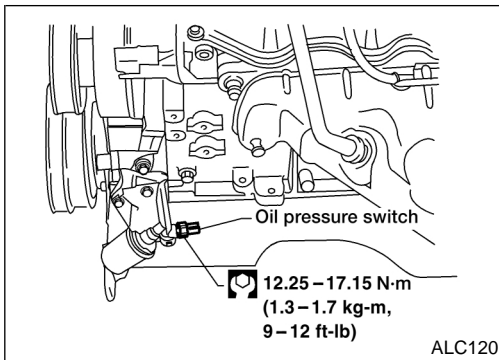

## Oil Pressure Check

### WARNING:

- Be careful not to burn yourself, as the engine and oil may be hot.
- Oil pressure check should be done in “Neutral position” (M/T) or “Parking position” (A/T).

1. Check oil level.
2. Remove oil pressure switch.
3. Install pressure gauge.
4. Start engine and warm it up to normal operating temperature.
5. Check oil pressure with engine running under no-load.

Engine speed rpm	Approximate discharge pressure kPa (kg/cm <sup>2</sup> , psi)
Idle speed	More than 59 (0.6, 9)
2,000	412 - 451 (4.2 - 4.6, 60 - 65)

**If difference is extreme, check oil passage and oil pump for oil leaks.**

6. Install oil pressure switch with sealant.

 : 12.25 - 17.15 N·m (1.3 - 1.7 kg-m, 9 - 12 ft-lb)

## Oil Pump

### REMOVAL AND INSTALLATION

NGLC0005

1. Drain engine oil.
2. Drain engine coolant from drain plug on radiator.
3. Remove air duct (from mass air flow sensor to throttle body).
4. Remove cooling fan.
5. Remove radiator hoses (upper and lower) and fan shroud. Refer to “Radiator”.
6. Remove drive belts. Refer to **MA-26** (“Checking Drive Belts”).
7. Remove crankshaft pulley and front upper and lower belt covers. Refer to **EM-75** (“TIMING BELT”).
8. Remove oil pan. Refer to **EM-72** (“OIL PAN”).
9. Remove oil strainer.
10. Remove oil pump assembly.

## DISASSEMBLY AND ASSEMBLY

NGLC0006

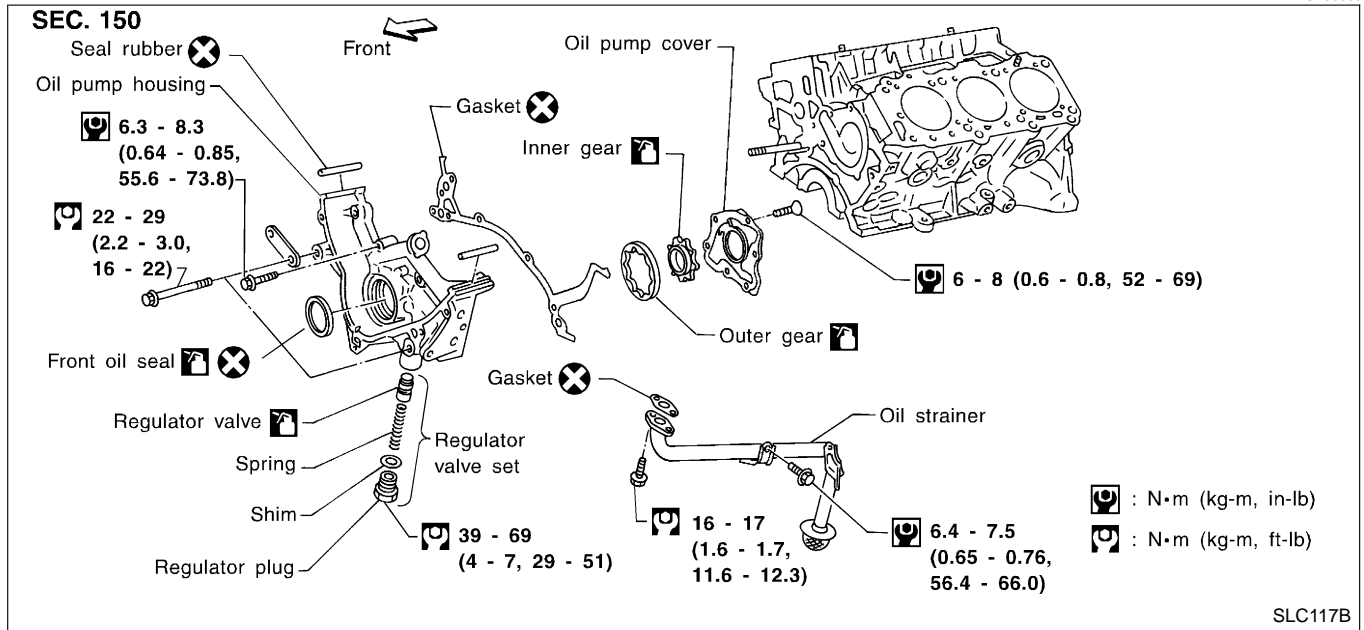

- Always replace with new oil seal and gasket.
- When installing oil pump, apply engine oil to inner and outer gears.
- Be sure that O-ring is properly installed.

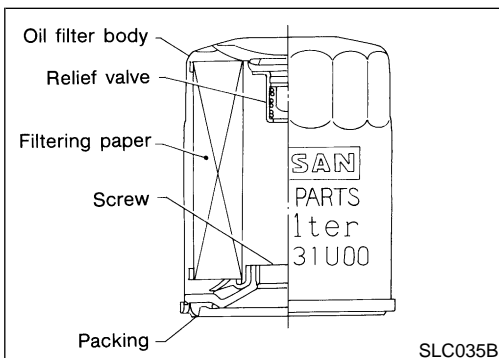
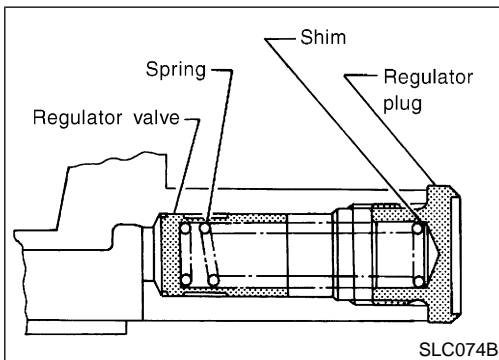
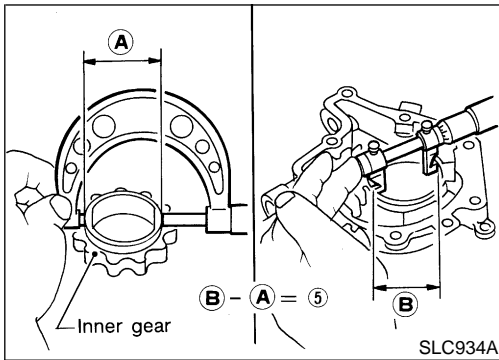
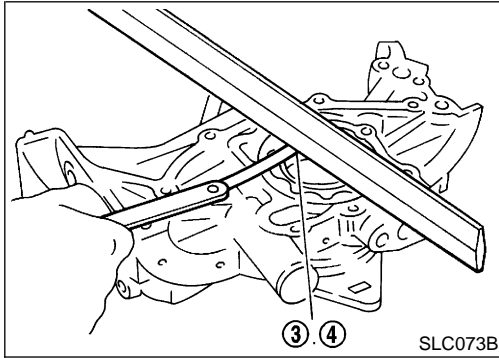
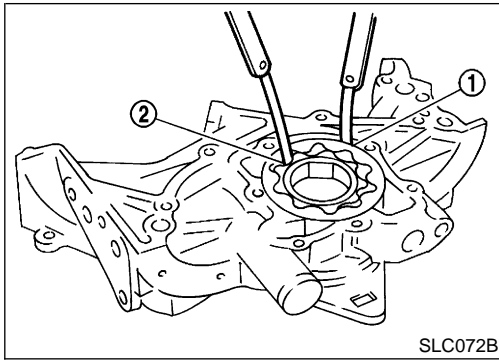

## INSPECTION

NGLC0007

Using a feeler gauge, straightedge and micrometers, check the following clearances:

Unit: mm (in)

Body to outer gear radial clearance 1	0.114 - 0.200 (0.0045 - 0.0079)
Inner gear to outer gear tip clearance 2	Below 0.18 (0.0071)
Body to inner gear axial clearance 3	0.05 - 0.09 (0.0020 - 0.0035)
Body to outer gear axial clearance 4	0.050 - 0.110 (0.0020 - 0.0043)
Inner gear to brazed portion of housing clearance 5	0.045 - 0.091 (0.0018 - 0.0036)

- If the tip clearance (2) exceeds the limit, replace gear set.
- If body to gear clearances (1, 3, 4, 5) exceed the limit, replace oil pump body assembly.

## REGULATOR VALVE INSPECTION

NGLC0008

1. Visually inspect components for wear and damage.
2. Check oil pressure regulator valve sliding surface and valve spring.
3. Coat regulator valve with engine oil. Check that it falls smoothly into the valve hole by its own weight.

If damaged, replace regulator valve set or oil pump assembly.

## OIL FILTER

NGLC0009

The oil filter is a small, full-flow cartridge type and is provided with a relief valve.

- The new and previous oil filter designs differ from each other and are not interchangeable.
- Use Tool KV10115801 (J38956) for removing oil filter.

## Oil Pump (Cont'd)

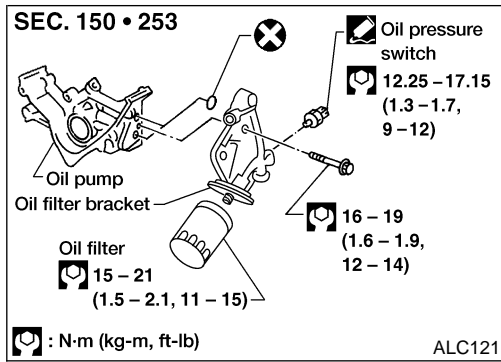

## OIL FILTER BRACKET

NGLC0010

1. Remove oil filter.
2. Disconnect oil pressure switch and connector.
3. Remove oil filter bracket.

## Service Data and Specifications (SDS)

### OIL PRESSURE CHECK

NGLC0011

Engine speed rpm	Approximate discharge pressure kPa (kg/cm <sup>2</sup> , psi)
Idle speed	More than 59 (0.6, 9)
2,000	412 - 451 (4.2 - 4.6, 60 - 65)

### REGULATOR VALVE

NGLC0012

Unit: mm (in)

Regulator valve to oil pump cover clearance	0.040 - 0.097 (0.0016 - 0.0038)
---	---------------------------------

### OIL PUMP

NGLC0013

Unit: mm (in)

Body to outer gear radial clearance	0.114 - 0.200 (0.0045 - 0.0079)
Inner gear to outer gear tip clearance	Below 0.18 (0.0071)
Body to inner gear axial clearance	0.05 - 0.09 (0.0020 - 0.0035)
Body to outer gear axial clearance	0.050 - 0.110 (0.0020 - 0.0043)
Inner gear to brazed portion of housing clearance	0.045 - 0.091 (0.0018 - 0.0036)



## Precautions

### SUPPLEMENTAL RESTRAINT SYSTEM (SRS) "AIR BAG"

NGLC0135

The Supplemental Restraint System "AIR BAG" and "SEAT BELT PRE-TENSIONER", used along with a seat belt, helps to reduce the risk or severity of injury to the driver and front passenger in certain types collisions. The Supplemental Restraint System consists of air bag modules (located in the center of the steering wheel), a front passenger air bag module (located on the instrument panel on the passenger side), seat belt pre-tensioners, a diagnosis sensor unit, a crash zone sensor (4WD models), a warning lamp, wiring harness, and spiral cable.

Information necessary to service the system safely is included in the **RS section** of this Service Manual.

#### **WARNING:**

- To avoid rendering the SRS inoperative, which could increase the risk of personal injury or death in the event of a collision which would result in air bag inflation, all maintenance should be performed by an authorized NISSAN dealer.
- Improper maintenance, including incorrect removal and installation of the SRS, can lead to personal injury caused by unintentional activation of the system. For removal of Spiral Cable and Air Bag Module, refer to *RS-16*.
- Do not use electrical test equipment on any circuit related to the SRS unless instructed to in this Service Manual. Spiral cable and wiring harnesses (except "SEAT BEAT PRE-TENSIONER") covered with yellow insulation either just before the harness connectors or on the complete harness, are related to the SRS.

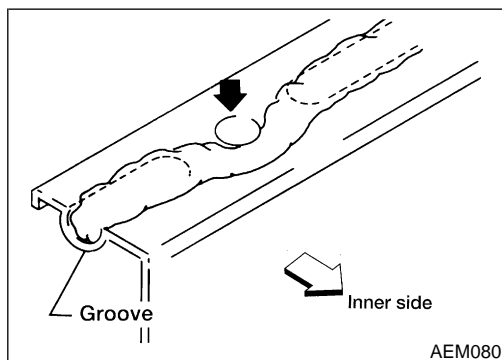
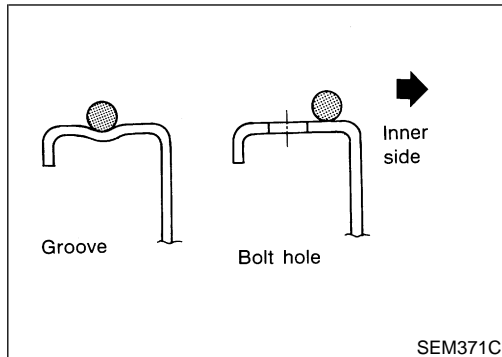

### LIQUID GASKET APPLICATION PROCEDURE

NGLC0014

1. Use a scraper to remove all traces of old liquid gasket from mating surface and grooves. Also, completely clean any oil from these areas.
2. Apply a continuous bead of liquid gasket to mating surfaces. (Use Genuine RTV silicone sealant Part No. 999MP-A7007 or equivalent.)
  - Be sure liquid gasket is 3.5 to 4.5 mm (0.138 to 0.177 in) dia. (for oil pan).
  - Be sure liquid gasket is 2.0 to 3.0 mm (0.079 to 0.118 in) dia. (in areas except oil pan).
3. Apply liquid gasket around the inner side of bolt holes (unless otherwise specified).
4. Assembly should be done within 5 minutes after coating.
5. Wait at least 30 minutes before refilling engine oil and engine coolant.

## Preparation

### SPECIAL SERVICE TOOLS

The actual shapes of Kent-Moore tools may differ from those of special service tools illustrated here. =NGLC0015

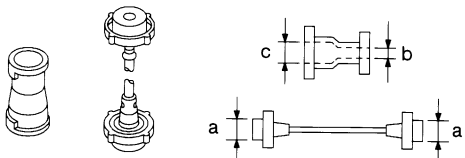
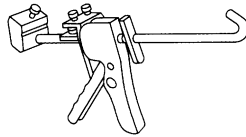
Tool number (Kent-Moore No.) Tool name	Description	
EG17650301 (J33984-A) Radiator cap tester adapter		Adapting radiator cap tester to radiator filler neck <b>a: 28 (1.10) dia.</b> <b>b: 31.4 (1.236) dia.</b> <b>c: 41.3 (1.626) dia.</b> Unit: mm (in)
WS39930000 ( — ) Tube presser		Pressing the tube of liquid gasket

## Cooling Circuit

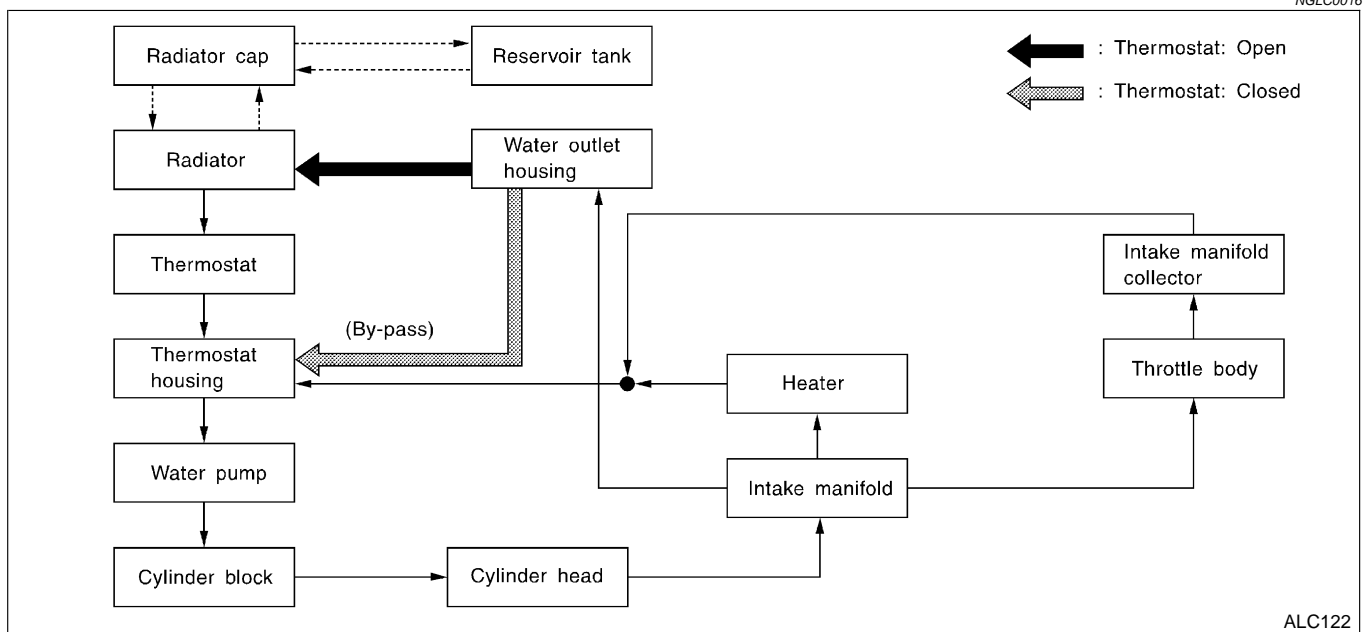

## System Check

### WARNING:

Never remove the radiator cap when the engine is hot. Serious burns could occur from high pressure coolant escaping from the radiator.

Wrap a thick cloth around the cap. Slowly turn it a quarter turn to allow built-up pressure to escape. Carefully remove the cap by turning it all the way.

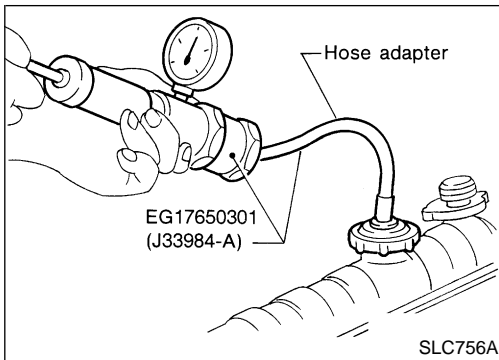

## CHECKING COOLING SYSTEM HOSES

NGLC0017S01

Check hoses for improper attachment, leaks, cracks, damage, loose connections, chafing and deterioration.

GI

MA

EM

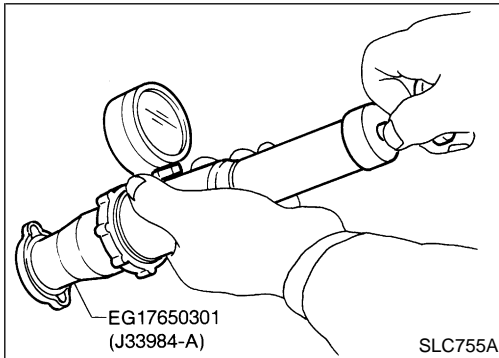
**LC**

## CHECKING RADIATOR CAP

NGLC0017S02

To check radiator cap, apply pressure to cap with a tester.

### Radiator cap relief pressure:

#### Standard

78 - 98 kPa (0.8 - 1.0 kg/cm<sup>2</sup>, 11 - 14 psi)

#### Limit

59 - 98 kPa (0.6 - 1.0 kg/cm<sup>2</sup>, 9 - 14 psi)

EC

FE

CL

MT

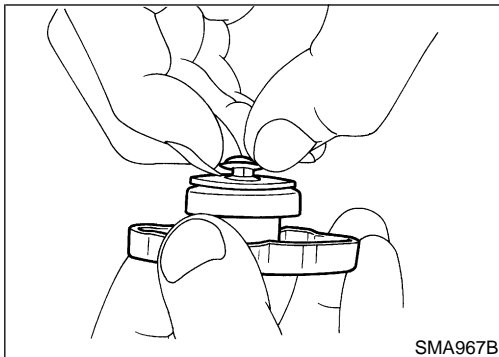

Pull the negative pressure valve to open it. Check that it closes completely when released.

## CHECKING RADIATOR

NGLC0017S04

Check radiator for mud or clogging. If necessary, clean radiator as follows.

- Be careful not to bend or damage the radiator fins.
  - When radiator is cleaned without removal, remove all surrounding parts such as cooling fan, radiator shroud and horns.
  - Tape the harness connectors to prevent water from entering.
- 1) Apply water by hose to the back side of the radiator core vertically downward.
  - 2) Apply water again to all radiator core surfaces once per minute.
  - 3) Stop washing when stains no longer flow out from the radiator.
  - 4) Blow air into the back side of radiator core vertically downward.
    - Use compressed air lower than 490 kPa (5 kg/cm<sup>2</sup>, 71 psi) and keep distance more than 30 cm (11.8 in).
  - 5) Blow air again into all the radiator core surfaces once per minute until no water sprays out.

AT

TF

PD

AX

SU

BR

ST

RS

## CHECKING COOLING SYSTEM FOR LEAKS

NGLC0017S03

To check for leakage, apply pressure to the cooling system with a tester.

**Testing pressure: 157 kPa (1.6 kg/cm<sup>2</sup>, 23 psi)**

### CAUTION:

Higher pressure than specified may cause radiator damage.

BT

HA

SC

EL

IDX

## Water Pump REMOVAL

NGLC0018

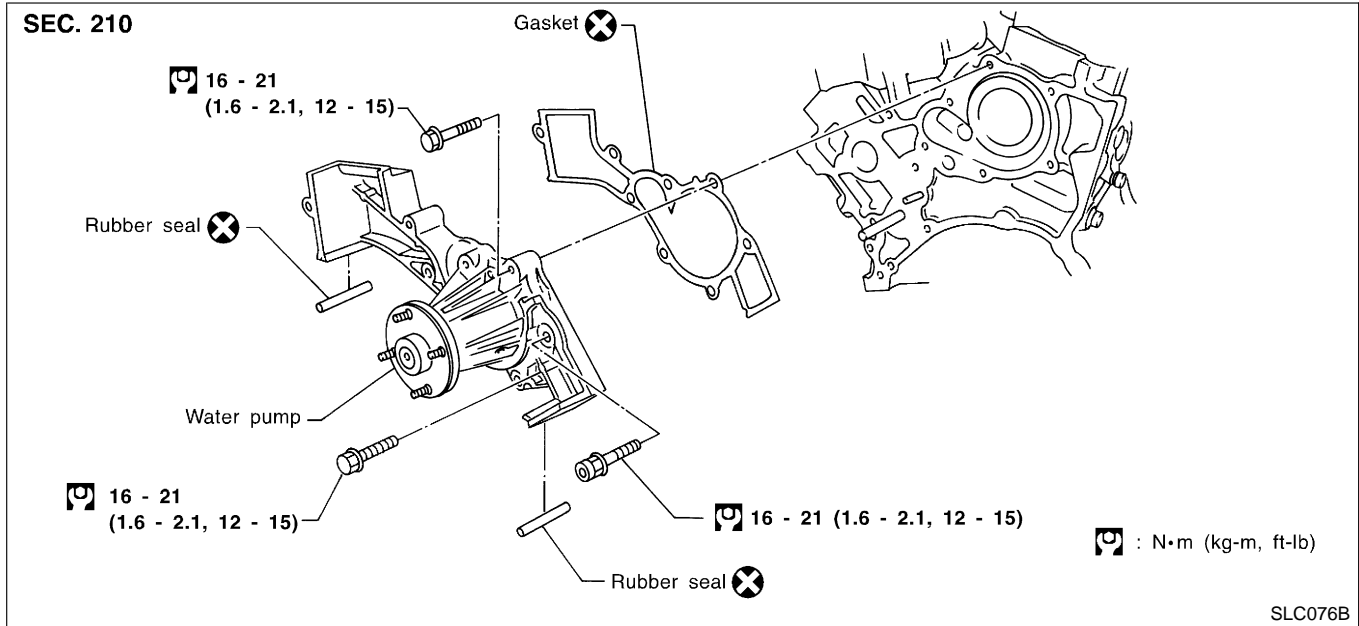

**CAUTION:**

- When removing water pump assembly, be careful not to get coolant on timing belt.
- Water pump cannot be disassembled and should be replaced as a unit.
- After installing water pump, connect hose and clamp securely, then check for leaks using radiator cap tester.
- To avoid deforming timing cover, make sure there is adequate clearance between it and the hose clamp.

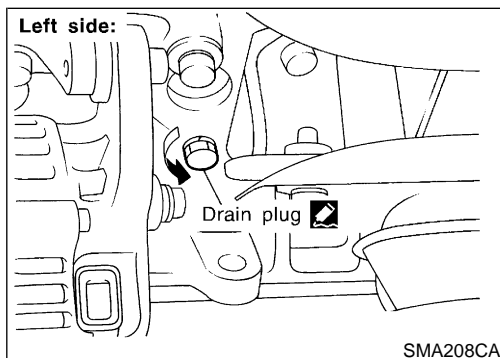
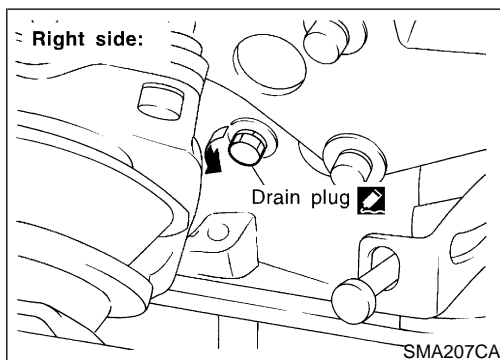

1. Drain coolant from drain plugs on both sides of cylinder block and radiator. Refer to **MA-27** ("Changing Engine Coolant").

2. Remove radiator hoses (upper and lower) and fan shroud. Refer to "Radiator".
3. Remove drive belts. Refer to MA **MA-26** ("Checking Drive Belts").
4. Remove water pump pulley.
5. Remove crankshaft pulley and front (upper and lower) belt cover. Refer to **EM-75** ("TIMING BELT").
6. Remove water pump.

GI

MA

EM

LC

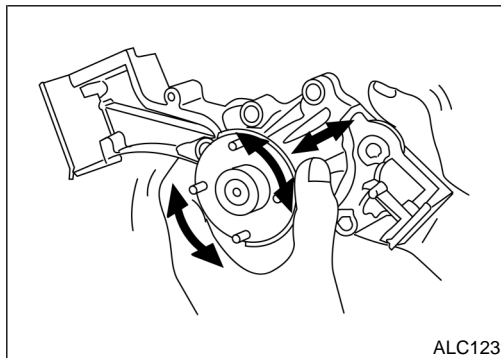

ALC123

## INSPECTION

1. Check for badly rusted or corroded body assembly and vanes. NGLC0019
2. Check for rough operation due to excessive end play. EC

EC

FE

CL

MT

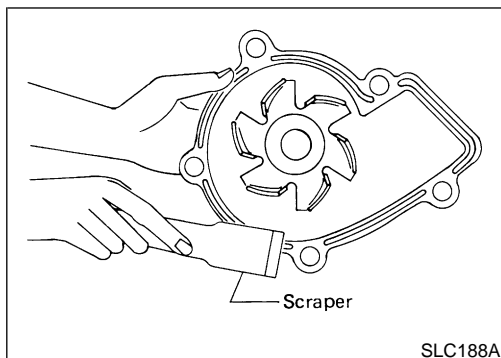

SLC188A

## INSTALLATION

1. Use a scraper to remove liquid gasket from water pump. NGLC0132
  - **Also remove traces of liquid gasket from mating surface of cylinder block.**

AT

TF

PD

AX

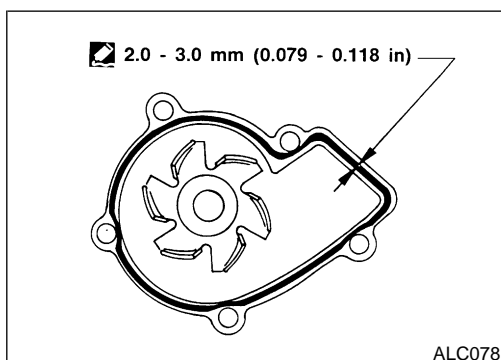

ALC078

2. Apply a continuous bead of liquid gasket to mating surface of water pump.
  - **Use Genuine RTV Silicone Sealant Part No. 999 MP-A7007 or equivalent.**

SU

BR

**When filling radiator with coolant, refer to MA-27 ("Changing Engine Coolant", "ENGINE MAINTENANCE").**  
**When installing drive belts, refer to MA-26 ("Checking Drive Belts").**

ST

RS

## Thermostat

### REMOVAL

1. Drain engine coolant from drain plugs on radiator. NGLC0020
2. Remove radiator hoses (upper and lower) and fan shroud.
3. Remove drive belts.
4. Remove pulley bracket.
5. Remove water inlet and thermostat assembly.

BT

HA

SC

EL

IDX

Thermostat (Cont'd)

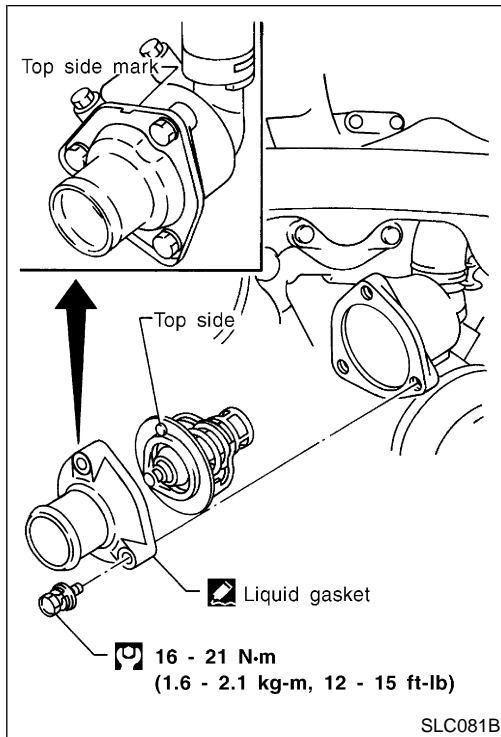

## INSPECTION

NGLC0021

1. Check valve seating condition at ordinary temperatures. It should seat tightly.

2. Check valve opening temperature and valve lift.

Valve opening temperature	°C (°F)	82 (180)
Valve lift	mm/°C (in/°F)	More than 10/95 (0.39/203)

3. Then check if valve is closed at 5°C (9°F) below valve opening temperature.

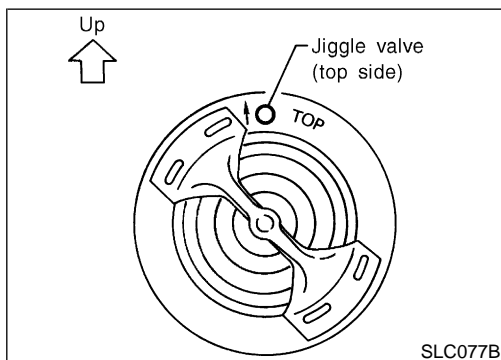
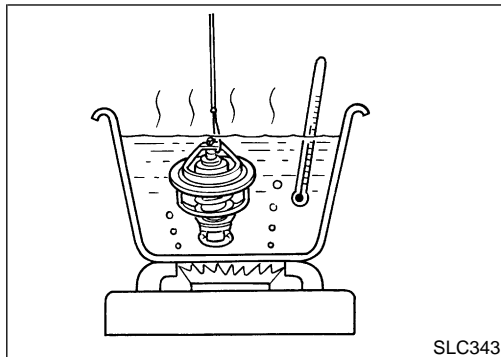

## INSTALLATION

NGLC0022

1. Install thermostat with jiggle valve or air bleeder at upper side.

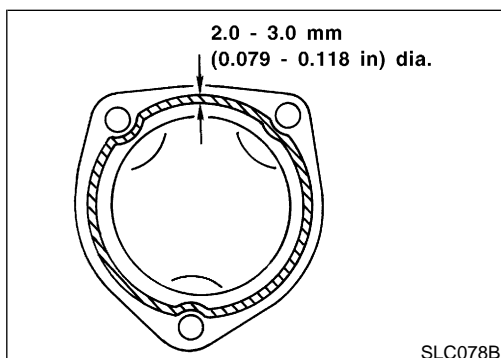

2. When installing water inlet apply liquid gasket as shown.
  - After installation, run engine for a few minutes, and check for leaks.
  - Be careful not to spill coolant over engine compartment. Use a rag to absorb coolant.

## Radiator REMOVAL AND INSTALLATION

NGLC0023

1. Remove under cover.
2. Drain coolant from radiator drain plug.
3. Remove air duct. (From mass air flow sensor to throttle body)
4. Disconnect radiator upper and lower hoses.
5. Remove A/T oil cooler hoses. (A/T model only)
6. Remove radiator lower shroud.
7. Disconnect reservoir tank hose.
8. Remove radiator.
9. After repairing or replacing radiator, install any part removed in reverse order of removal.

GI

MA

EM

**LC**

EC

FE

CL

MT

## COMPONENTS

NGLC0024

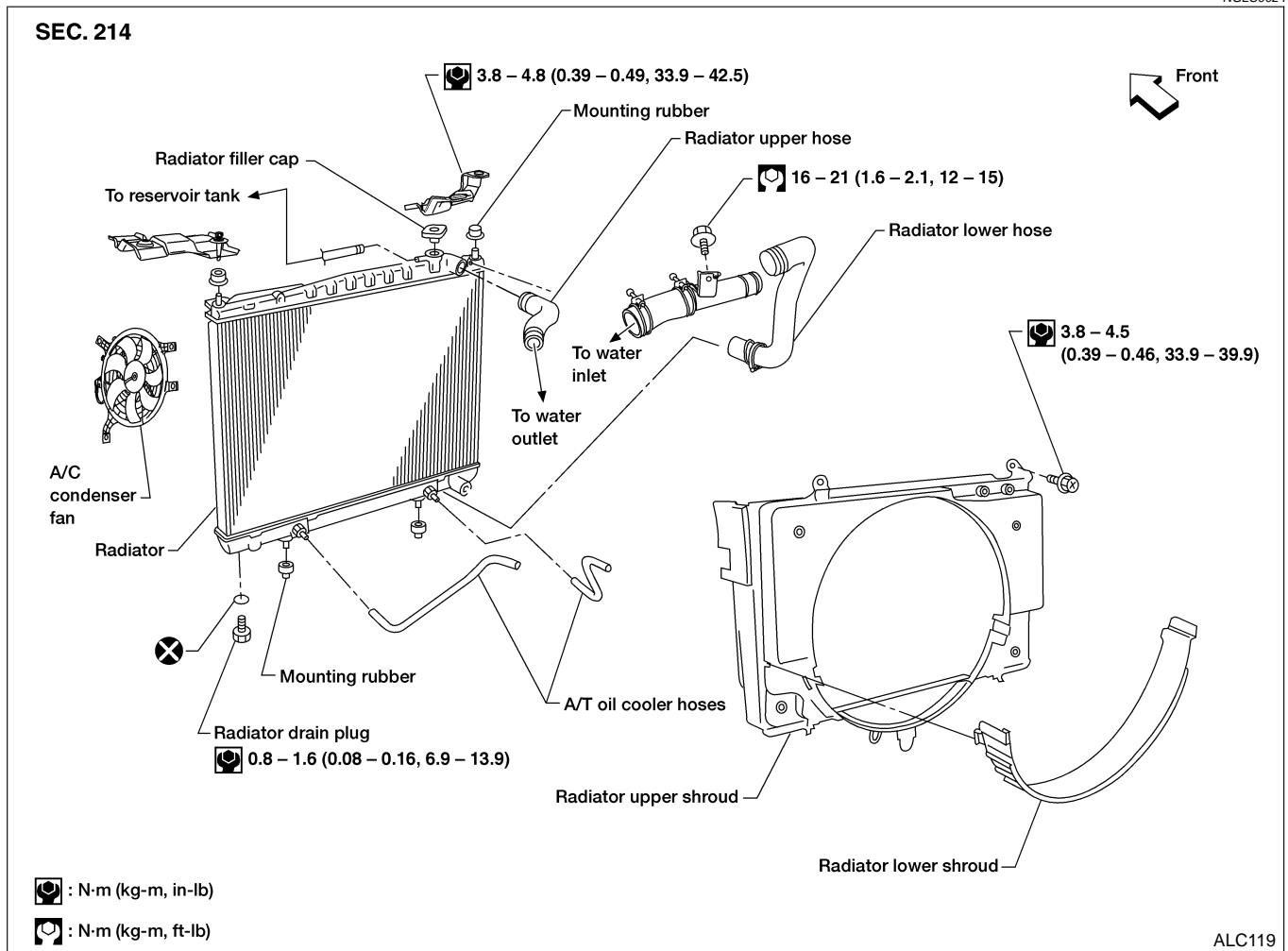

AT

TF

PD

AX

SU

BR

ST

RS

BT

HA

SC

EL

IDX

## Radiator (Cont'd)

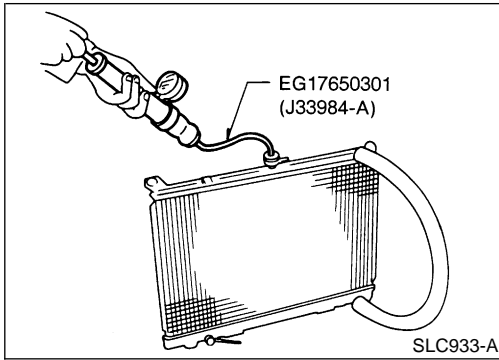

### INSPECTION

NGLC0028

1. Apply pressure with Tool.

**Specified pressure value:**

**157 kPa (1.6 kg/cm<sup>2</sup>, 23 psi)**

### WARNING:

To prevent the risk of the hose coming undone while under pressure, securely fasten it down with a hose clamp. Attach a hose to the oil cooler as well. (A/T model only)

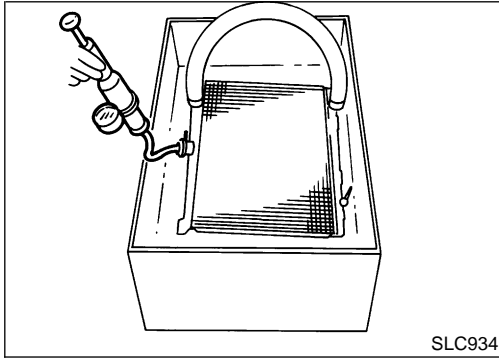

2. Check for leakage.

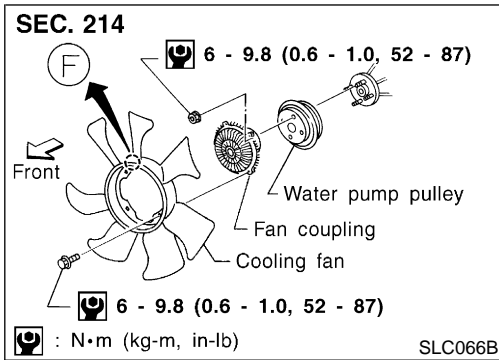

## Cooling Fan (Crankshaft driven)

### REMOVAL AND INSTALLATION

NGLC0029

- Do not release the drive belt tension by removing the fan/water pump pulley.
- Fan coupling cannot be disassembled and should be replaced as a unit. If front mark **F** is present, install fan so that side marked **F** faces the front.
- Install the drive belt only after the fan and fan coupling to water pump flange bolts/nuts have been properly torqued.
- Proper alignment of these components is essential. Improper alignment will cause them to wobble and may eventually cause the fan to separate from the water pump causing extensive damage.

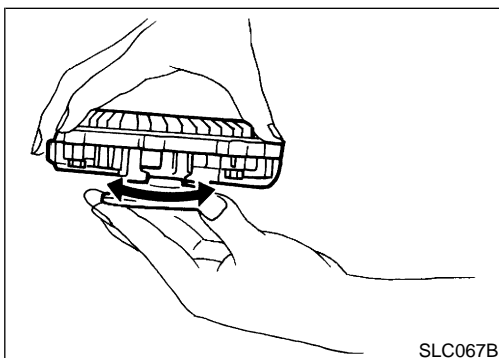

### INSPECTION

NGLC0030

Check fan coupling for rough operation, wobbling, oil leakage or bent bimetal.



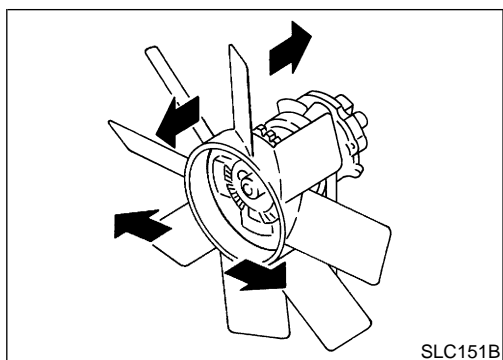

After assembly, verify the fan does not wobble or flap while the engine is running.

**WARNING:**

- When the engine is running, keep hands and clothing away from moving parts such as drive belts and fan.

GI

MA

EM

**LC**

EC

FE

CL

MT

AT

TF

PD

AX

SU

BR

ST

RS

BT

HA

SC

EL

IDX

## Refilling Engine Coolant

For details on refilling engine coolant, refer to MA section (“REFILLING ENGINE COOLANT”, “Changing Engine Coolant”). =NGLC0031

## Overheating Cause Analysis

NGLC0032

	Symptom		Check items		
Cooling system parts malfunction	Poor heat transfer	Water pump malfunction	—	—	
		Thermostat stuck closed	—		
		Damaged fins	Dust contamination or paper clogging		—
			Mechanical damage		
		Clogged radiator cooling tube	Excess foreign material (rust, dirt, sand, etc.)		
	Reduced air flow	Cooling fan does not operate	—	—	
		High resistance to fan rotation			
		Damaged fan blades			
		Damaged radiator shroud	—	—	
		Improper coolant mixture ratio	—	—	
		Poor coolant quality	—	—	
	Insufficient coolant	Coolant leaks	Cooling hose	Loose clamp	
				Cracked hose	
			Water pump	Poor sealing	
			Radiator cap	Loose	
Poor sealing					
Radiator		O-ring for damage, deterioration or improper fitting			
		Cracked radiator tank			
		Cracked radiator core			
	Reservoir tank	Cracked reservoir tank			
Overflowing reservoir tank	Exhaust gas leaks into cooling system	Cylinder head deterioration			
		Cylinder head gasket deterioration			

# ENGINE COOLING SYSTEM

**VG33E**

Overheating Cause Analysis (Cont'd)

	Symptom		Check items			
Except cooling system parts malfunction	—	Overload on engine	Abusive driving	High engine rpm under no-load	GI	
				Driving in low gear for extended time	MA	
				Driving at extremely high speed	EM	
			Powertrain system malfunction	—	LC	
			Installed improper size wheels and tires		EC	
			Dragging brakes		FE	
	Blocked or restricted air flow	Blocked bumper	—	—	CL	
			Blocked radiator grille		Installed car brassiere	GL
					Mud contamination or paper clogging	MT
			Blocked radiator		—	AT
			Blocked condenser		—	AT
Installed large fog lamp	—					

## Service Data and Specifications (SDS)

### THERMOSTAT

NGLC0033

Valve opening temperature °C (°F)	82 (180)	PD
Valve lift mm/°C (in/°F)	More than 10/95 (0.39/203)	

### RADIATOR

NGLC0034

Unit: kPa (kg/cm<sup>2</sup>, psi)

Cap relief pressure	Standard	78 - 98 (0.8 - 1.0, 11 - 14)	SU
	Limit	59 - 98 (0.6 - 1.0, 9 - 14)	
Leakage test pressure		157 (1.6, 23)	BR

## NOTES