

# BODY & TRIM

# SECTION BT

## CONTENTS

<b>PRECAUTIONS</b> .....	2	<b>INSTRUMENT PANEL ASSEMBLY</b> .....	20
Service Notice.....	2	Removal and Installation .....	20
Supplemental Restraint System (SRS) "AIR BAG" and "SEAT BELT PRE-TENSIONER".....	2	<b>SIDE AND FLOOR TRIM</b> .....	24
<b>PREPARATION</b> .....	3	Removal and Installation .....	24
Special Service Tools .....	3	<b>DOOR TRIM</b> .....	27
Commercial Service Tools .....	3	Removal and Installation .....	27
<b>SQUEAK AND RATTLE TROUBLE DIAGNOSES</b> .....	4	<b>ROOF TRIM</b> .....	30
Work Flow.....	4	Removal and Installation .....	30
CUSTOMER INTERVIEW .....	4	<b>BACK DOOR TRIM</b> .....	31
DUPLICATE THE NOISE AND TEST DRIVE .....	5	Removal and Installation .....	31
CHECK RELATED SERVICE BULLETINS .....	5	<b>EXTERIOR</b> .....	32
LOCATE THE NOISE AND IDENTIFY THE ROOT CAUSE .....	5	Removal and Installation .....	32
REPAIR THE CAUSE.....	5	<b>FRONT SEAT</b> .....	37
CONFIRM THE REPAIR.....	6	Removal and Installation .....	37
Generic Squeak and Rattle Troubleshooting .....	6	<b>REAR SEAT</b> .....	38
INSTRUMENT PANEL.....	6	Removal and Installation .....	38
CENTER CONSOLE .....	6	<b>SUNROOF</b> .....	39
DOORS.....	6	Removal and Installation .....	39
TRUNK .....	7	<b>WINDSHIELD AND WINDOWS</b> .....	40
SUNROOF AND HEADLINER.....	7	Removal and Installation .....	40
SEATS.....	7	REMOVAL.....	40
UNDERHOOD .....	7	INSTALLATION.....	40
Diagnostic Worksheet.....	8	WINDSHIELD .....	41
<b>CLIP AND FASTENER</b> .....	10	REAR SIDE WINDOW.....	42
Description .....	10	<b>REAR VIEW MIRROR</b> .....	44
<b>BODY FRONT END</b> .....	12	Removal.....	44
Removal and Installation .....	12	Installation.....	44
FRONT BUMPER ASSEMBLY .....	12	<b>DOOR MIRROR</b> .....	45
<b>BODY REAR END AND OPENER</b> .....	15	Removal and Installation .....	45
Removal and Installation .....	15	<b>CAB AND REAR BODY</b> .....	46
REAR BUMPER ASSEMBLY .....	15	Body Mounting.....	46
<b>FRONT DOOR</b> .....	18	<b>BODY (ALIGNMENT)</b> .....	47
Overhaul .....	18	Alignment.....	47
<b>REAR DOOR</b> .....	19	ENGINE COMPARTMENT.....	48
Overhaul .....	19	UNDERBODY.....	50

GI  
MA  
EM  
LC  
EC  
FE  
CL  
MT  
AT  
TF  
PD  
AX  
SU  
BR  
ST  
RS  
BT  
HA  
SC  
EL  
IDX

# PRECAUTIONS

Service Notice

---

## Service Notice

NGBT0001

- When removing or installing various parts, place a cloth or padding onto the vehicle body to prevent scratches.
- Handle trim, molding, instruments, grille, etc. carefully during removing or installing. Be careful not to soil or damage them.
- Apply sealing compound where necessary when installing parts.
- When applying sealing compound, be careful that the sealing compound does not protrude from parts.
- When replacing any metal parts (for example body outer panel, members, etc.), be sure to take rust prevention measures.

## Supplemental Restraint System (SRS) “AIR BAG” and “SEAT BELT PRE-TENSIONER”

NGBT0002

The Supplemental Restraint System such as “AIR BAG” and “SEAT BELT PRE-TENSIONER”, used along with a seat belt, helps to reduce the risk or severity of injury to the driver and front passenger for certain types of collision. The Supplemental Restraint System consists of driver air bag module (located in the center of the steering wheel), front passenger air bag module (located on the instrument panel on passenger side), seat belt pre-tensioners, a diagnosis sensor unit, warning lamp, wiring harness and spiral cable. Information necessary to service the system safely is included in the **RS section** of this Service Manual.

### **WARNING:**

- **To avoid rendering the SRS inoperative, which could increase the risk of personal injury or death in the event of a collision which would result in air bag inflation, all maintenance should be performed by an authorized NISSAN dealer.**
- **Improper maintenance, including incorrect removal and installation of the SRS, can lead to personal injury caused by unintentional activation of the system. For removal of Spiral Cable and Air Bag Module, see the RS section.**
- **Do not use electrical test equipment on any circuit related to the SRS unless instructed to in this Service Manual. Spiral cable and wiring harness (except “SEAT BELT PRE-TENSIONER”) covered with yellow insulation either just before the harness connectors or for the complete harness are related to the SRS.**

# PREPARATION

Special Service Tools

## Special Service Tools

NGBT0027

The actual shapes of Kent-Moore tools may differ from those of special service tools illustrated here.

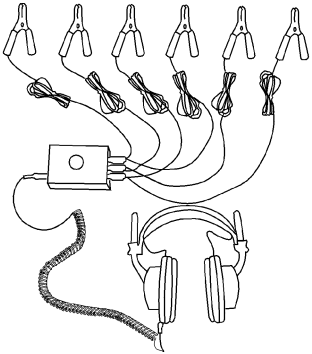
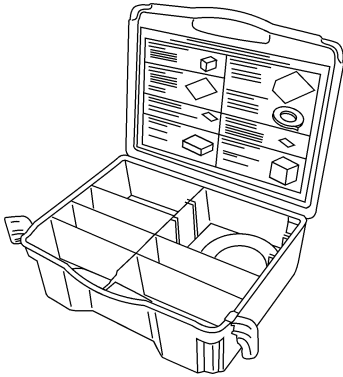
Tool number (Kent-Moore No.) Tool name	Description	
(J-39570) Chassis Ear	 <p data-bbox="992 352 1182 380">Locating the noise</p> <p data-bbox="440 720 509 741">ABT465</p>	<p>GI</p> <p>MA</p> <p>EM</p> <p>LC</p> <p>EC</p> <p>FE</p>
(J-43980) Nissan Squeak and Rattle Kit	 <p data-bbox="992 758 1182 785">Locating the noise</p> <p data-bbox="440 1161 509 1182">ABT474</p>	<p>CL</p> <p>MT</p> <p>AT</p> <p>TF</p> <p>PD</p>

## Commercial Service Tools

NGBT0028

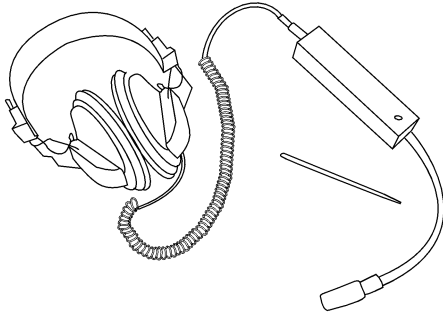
Tool number (Kent-Moore No.) Tool name	Description	
(J-39565) Engine Ear	 <p data-bbox="992 1442 1182 1470">Locating the noise</p> <p data-bbox="440 1812 509 1833">ABT466</p>	<p>SU</p> <p>BR</p> <p>ST</p> <p>RS</p> <p><b>BT</b></p> <p>HA</p> <p>SC</p> <p>EL</p> <p>IDX</p>

# SQUEAK AND RATTLE TROUBLE DIAGNOSES

Work Flow

## Work Flow

NGBT0026S01

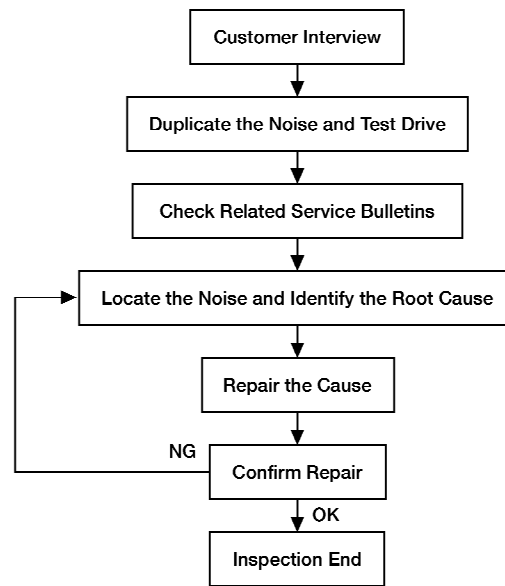

ABT488

### CUSTOMER INTERVIEW

NGBT0026S0101

Interview the customer, if possible, to determine the conditions that exist when the noise occurs. Use the Diagnostic Worksheet during the interview to document the facts and conditions when the noise occurs and any customer comments; refer to "Diagnostic Worksheet", BT-8. This information is necessary to duplicate the conditions that exist when the noise occurs.

- The customer may not be able to provide a detail description or location of the noise. Attempt to obtain all the facts and conditions that exist when the noise occurs (or does not occur).
- If there is more than one noise in the vehicle, be sure to diagnose and repair the noise that the customer is concerned about. This can be accomplished by test driving the vehicle with the customer.
- After identifying the type of noise, isolate the noise in terms of its characteristics. The noise characteristics are provided so the customer, service adviser and technician are all speaking the same language when defining the noise.

- Squeak-(Like tennis shoes on a clean floor)

Squeak characteristics include the light contact / fast movement / brought on by road conditions / hard surfaces = higher pitch noise / softer surfaces = lower pitch noises / edge to surface = chirping.

- Creak-(Like walking on an old wooden floor)

Creak characteristics include firm contact / slow movement / twisting with a rotational movement / pitch dependent on materials / often brought on by activity.

- Rattle-(Like shaking a baby rattle)

Rattle characteristics include the fast repeated contact / vibration or similar movement / loose parts / missing clip or fastener / incorrect clearance.

- Knock-(Like a knock on a door)

Knock characteristics include hollow sound / something repeating / often brought on by driver action.

- Tick-(Like a clock second hand)

Tick characteristics include light contact of light material / loose components / can be caused by driver action on road conditions.

- Thump-(Heavy, muffled knock noise)

Thump characteristics include softer knock / dead sound often brought on by activity.

- Buzz-(Like a bumblebee)

Buzz characteristics include high frequency rattle / firm contact

- Often the degree of acceptable noise level will vary depending upon the person. A noise that you may judge as acceptable may be very irritating to the customer.

- Weather conditions, especially humidity and temperature, may have a great effect on noise level.

# SQUEAK AND RATTLE TROUBLE DIAGNOSES

Work Flow (Cont'd)

## DUPLICATE THE NOISE AND TEST DRIVE

NGBT0026S0102

If possible, drive the vehicle with the customer until the noise is duplicated. Note any additional information on the Diagnostic Worksheet regarding the conditions or locations of the noise. This information can be used to duplicate the same conditions when you confirm the repair.

If the noise can be duplicated easily during the test drive, to help identify the source of the noise, try to duplicate the noise with the vehicle stopped by doing one or all of the following:

- 1) Close a door.
- 2) Tap or push / pull around the area where the noise appears to be coming from.
- 3) Rev the engine.
- 4) Use a floor jack to recreate vehicle "twist".
- 5) At idle, apply engine load (electric load, half-clutch on M/T model, drive position on A/T model).
- 6) Raise the vehicle on a hoist and hit a tire with rubber hammer.
  - Drive the vehicle and attempt to duplicate the conditions the customer states exist when the noise occurs.
  - If it is difficult to duplicate the noise, drive the vehicle slowly on an undulating or rough road to stress the vehicle body.

## CHECK RELATED SERVICE BULLETINS

NGBT0026S0103

After verifying the customer concern or symptom, check ASSIST for Technical Service Bulletins (TSBs) related to that concern or symptom.

If a TSB relates to the symptom, follow the procedure to repair the noise.

## LOCATE THE NOISE AND IDENTIFY THE ROOT CAUSE

NGBT0026S0104

1. Narrow down the noise to a general area. To help pinpoint the source of the noise, use a listening tool (Chassis Ear : J-39570, Engine Ear : J-39565 and mechanic's stethoscope).
2. Narrow down the noise to a more specific area and identify the cause of the noise by:
  - Removing the components in the area that you suspect the noise is coming from.

Do not use too much force when removing clips and fasteners, otherwise clips and fasteners can be broken or lost during the repair, resulting in the creation of new noise.

- Tapping or pushing/pulling the component that you suspect is causing the noise.

Do not tap or push/pull the component with excessive force, otherwise the noise will be eliminated only temporarily.

- Feeling for a vibration with your hand by touching the component(s) that you suspect is (are) causing the noise.
- Placing a piece of paper between components that you suspect are causing the noise.
- Looking for loose components and contact marks.

Refer to Generic Squeak and Rattle Troubleshooting,

## REPAIR THE CAUSE

NGBT0026S0105

- If the cause is a loose component, tighten the component securely.
- If the cause is insufficient clearance between components:
  - Separate components by repositioning or loosening and retightening the component, if possible.
  - insulate components with a suitable insulator such as urethane pads, foam blocks, felt cloth tape or urethane tape. A Nissan Squeak and Rattle Kit (J-43980) is available through your authorized Nissan Parts Department.

### CAUTION:

**Do not use excessive force as many components are constructed of plastic and may be damaged. Always check with the Parts Department for the latest parts information.**

The following material are contained in the Nissan Squeak and Rattle Kit (J-43980) Each item can be ordered separately as needed.

URETHANE PADS (1.5 mm thick)

insulates connectors, harness, etc.

76268–9E005 : 100 x 135 mm / 76884–71L01 : 60 x 85 mm / 76884–71L02 : 15 x 25 mm

INSULATOR (foam blocks)

Insulates components from contact. Can be used to fill space behind a panel.

73982–9E000 : 45 mm thick, 50 x 50 mm / 73982–50Y00 : 10 mm thick, 50 x 50 mm

# SQUEAK AND RATTLE TROUBLE DIAGNOSES

Work Flow (Cont'd)

---

INSULATOR (Light foam block)

80845-71L00 :30 mm thick, 30 x 50 mm

FELT CLOTH TAPE

Used to insulate where movement does not occur. Ideal for instrument panel applications.

68370-4B000 : 15 x 25 mm pad / 68239-13E00 : 5 mm wide tape roll

The following materials, not found in the kit, can also be used to repair squeaks and rattles.

UHMW (TEFLON) TAPE

Insulates where slight movement is present. Ideal for instrument panel applications.

SILICONE GREASE

Used in place of UHMW tape that will be visible or not fit.

Note : Will only last a few months.

SILICONE SPRAY

Use when grease cannot be applied.

DUCT TAPE

Use to eliminate movement.

## CONFIRM THE REPAIR

Confirm that the cause of a noise is repaired by test driving the vehicle. Operate the vehicle under the same conditions as when the noise originally occurred. Refer to the notes on the Diagnostic Worksheet.

NGBT0026S0106

## Generic Squeak and Rattle Troubleshooting

NGBT0026S02

### INSTRUMENT PANEL

NGBT0026S0201

Most incidents are caused by contact and movement between:

1. Cluster lid A and instrument panel
2. Acrylic lens and combination meter housing
3. Instrument panel to front pillar garnish
4. Instrument panel to windshield
5. Instrument panel mounting pins
6. Wiring harness behind the combination meter
7. A/C defroster duct and duct joint

These incidents can usually be located by tapping or moving the components to duplicate the noise or by pressing on the components while driving to stop the noise. Most of these incidents can be repaired by applying felt cloth tape or silicon spray (in hard to reach areas). Urethane pads can be used to insulate wiring harness.

### CAUTION:

**Do not use silicone spray to isolate a squeak or rattle. If you saturate the area with silicone, you will not be able to recheck the repair.**

### CENTER CONSOLE

NGBT0026S0202

Components to pay attention to include:

1. Shifter assembly cover to finisher.
2. A/C control unit and cluster lid C
3. Wiring harness behind audio and A/C control unit

The instrument panel repair and isolation procedures also apply to center console.

### DOORS

NGBT0026S0203

Pay attention to the:

1. Finisher on inner panel making a slapping noise
2. Inside handle escutcheon to door finisher
3. Wiring harnesses tapping
4. Door striker out of alignment causing a popping noise on starts and stops

Tapping or moving the components or pressing on them while driving to duplicate the conditions can isolate many of these incidents. You can usually insulate the areas with felt cloth or insulator foam blocks from the Nissan Squeak and Rattle Kit (J-43980) to repair the noise.

# SQUEAK AND RATTLE TROUBLE DIAGNOSES

Generic Squeak and Rattle Troubleshooting (Cont'd)

## TRUNK

NGBT0026S0204

Trunk noises are often caused by a loose jack or loose items put into the trunk by the owner.

In addition look for:

1. Trunk lid bumpers out of adjustment
2. Trunk lid striker out of adjustment
3. The trunk lid torsion bars knocking together
4. A loose license plate or bracket

Most of these incidents can be repaired by adjusting, securing, or insulating the item(s) or component(s) causing the noise.

## SUNROOF AND HEADLINER

NGBT0026S0205

Noises in the sunroof and headliner area can often be traced to one of the following:

1. Sunroof lid, rail, linkage or seals making a rattle or light knocking noise
2. Sunvisor shaft shaking in the holder
3. Front or rear windshield touching headliner and squeaking

Again, pressing on the components to stop the noise while duplicating the conditions can isolate most of these incidents. Repairs usually consist of insulating with felt cloth tape.

## SEATS

NGBT0026S0206

When isolating seat noises it's important to note the position of the seat and the load placed on the seat when the noise is present.

These conditions should be duplicated when verifying and isolating the cause of the noise.

Cause of seat noise include:

1. Headrest rods and holders
2. A squeak between the seat pad cushion and frame
3. The rear seat back lock and bracket

These noises can be isolated by moving or pressing on the suspected components while duplicating the conditions under which the noise occurs. Most of these incidents can be repaired by repositioning the component or applying urethane tape to the contact area.

## UNDERHOOD

NGBT0026S0207

Some interior noises may be caused by components under the hood or on the engine wall. The noise is then transmitted into the passenger compartment.

Causes of transmitted underhood noises include:

1. Any components mounted to the engine wall
2. Components that pass through the engine wall
3. Engine wall mounts and connectors
4. Loose radiator mounting pins
5. Hood striker out of adjustment

These noises can be difficult to isolate since they can not be reached from the interior of the vehicle. The best method is to secure, move or insulate one component at a time and test drive the vehicle. Also, engine RPM or load can be changed to isolate the noise.

Repair can usually be made by moving, adjusting, securing, or insulating the component causing the noise.

GI

MA

EM

LC

EC

FE

CL

MT

AT

TF

PD

AX

SU

BR

ST

RS

BT

HA

SC

EL

IDX

# SQUEAK AND RATTLE TROUBLE DIAGNOSES

## Diagnostic Worksheet



### SQUEAK & RATTLE DIAGNOSTIC WORKSHEET

Dear Nissan Customer:

We are concerned about your satisfaction with your Nissan vehicle. Repairing a squeak or rattle sometimes can be very difficult. To help us fix your Nissan right the first time, please take a moment to note the area of the vehicle where the squeak or rattle occurs and under what conditions. You may be asked to take a test drive with a service advisor or technician to ensure we confirm the noise you are hearing.

#### I. WHERE DOES THE NOISE COME FROM? (circle the area of the vehicle)

The illustrations are for reference only, and may not reflect the actual configuration of your vehicle.

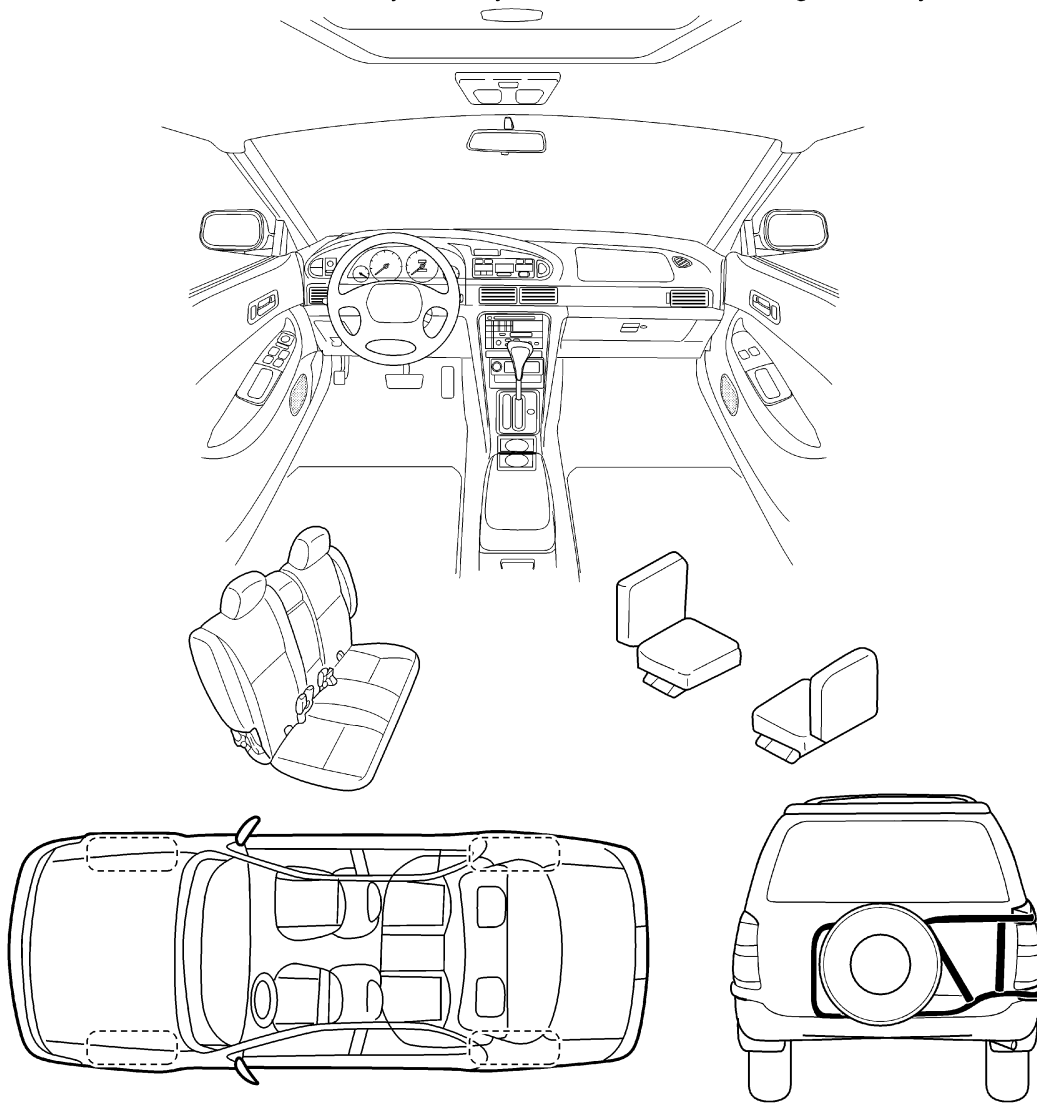

Continue to the back of the worksheet and briefly describe the location of the noise or rattle. In addition, please indicate the conditions which are present when the noise occurs.



# SQUEAK AND RATTLE TROUBLE DIAGNOSES

Diagnostic Worksheet (Cont'd)

## SQUEAK & RATTLE DIAGNOSTIC WORKSHEET- page 2

Briefly describe the location where the noise occurs:

---

---

### II. WHEN DOES IT OCCUR? (check the boxes that apply)

- |  |   |
|--|---|
| <input type="checkbox"/> anytime                             | <input type="checkbox"/> after sitting out in the sun |
| <input type="checkbox"/> 1 <sup>st</sup> time in the morning | <input type="checkbox"/> when it is raining or wet    |
| <input type="checkbox"/> only when it is cold outside        | <input type="checkbox"/> dry or dusty conditions      |
| <input type="checkbox"/> only when it is hot outside         | <input type="checkbox"/> other: _____                 |

### III. WHEN DRIVING:

- through driveways
- over rough roads
- over speed bumps
- only at about \_\_\_\_ mph
- on acceleration
- coming to a stop
- on turns : left, right or either (circle)
- with passengers or cargo
- other: \_\_\_\_\_
- after driving \_\_\_\_ miles or \_\_\_\_ minutes

### IV. WHAT TYPE OF NOISE?

- squeak (like tennis shoes on a clean floor)
- creak (like walking on an old wooden floor)
- rattle (like shaking a baby rattle)
- knock (like a knock on a door)
- tick (like a clock second hand)
- thump (heavy, muffled knock noise)
- buzz (like a bumble bee)

### TO BE COMPLETED BY DEALERSHIP PERSONNEL

Test Drive Notes:

---

---

	<u>YES</u>	<u>NO</u>	Initials of person <u>performing</u>
Vehicle test driven with customer	<input type="checkbox"/>	<input type="checkbox"/>	_____
- Noise verified on test drive	<input type="checkbox"/>	<input type="checkbox"/>	_____
- Noise source located and repaired	<input type="checkbox"/>	<input type="checkbox"/>	_____
- Follow up test drive performed to confirm repair	<input type="checkbox"/>	<input type="checkbox"/>	_____

VIN: \_\_\_\_\_ Customer Name: \_\_\_\_\_

W.O. #: \_\_\_\_\_ Date: \_\_\_\_\_

**This form must be attached to Work Order**

ABT469

GI  
MA  
EM  
LC  
EC  
FE  
CL  
MT  
AT  
TF  
PD  
AX  
SU  
BR  
ST  
RS  
BT  
HA  
SC  
EL  
IDX







# CLIP AND FASTENER

Description

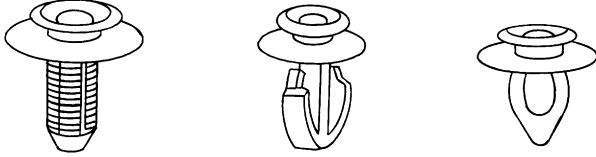
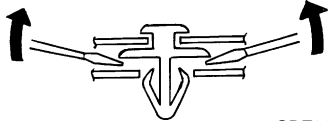
## Description

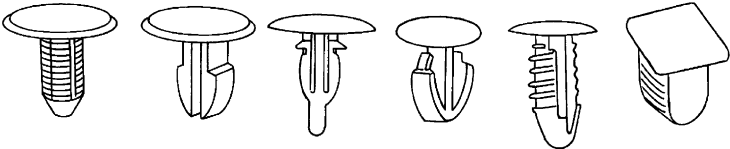
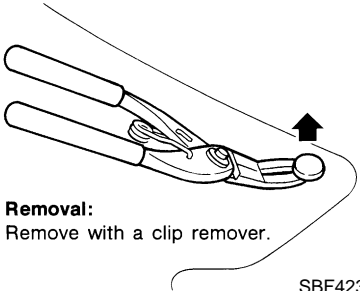
NGBT0003

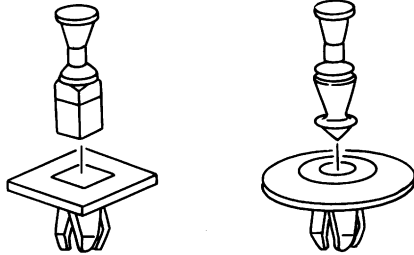
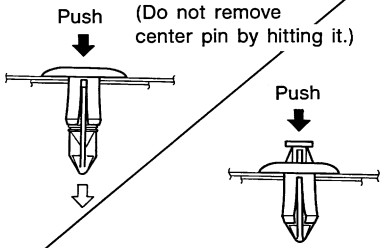
- Clips and fasteners in BT section correspond to the following numbers and symbols.
- Replace any clips and/or fasteners which are damaged during removal or installation.

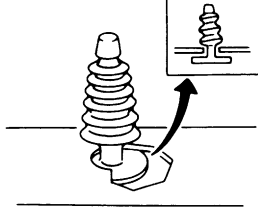
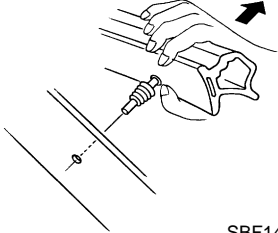
Symbol No.	Shapes	Removal & Installation
<p>C101</p> 	 <p>SBF302H</p>	<p><b>Removal:</b> Remove by bending up with flat-bladed screwdrivers or clip remover.</p>  <p>SBF367BA</p>
<p>C103</p> 	 <p>SBT095</p>	 <p><b>Removal:</b> Remove with a clip remover.</p> <p>SBF423H</p>
<p>C203</p> 	 <p>SBF258G</p>	<p>Push center pin to catching position. (Do not remove center pin by hitting it.)</p>  <p><b>Installation:</b></p> <p>SBF708E</p>
<p>CE103</p> 	 <p>SBF104B</p>	<p><b>Removal:</b></p>  <p>SBF147B</p>

# CLIP AND FASTENER

Description (Cont'd)

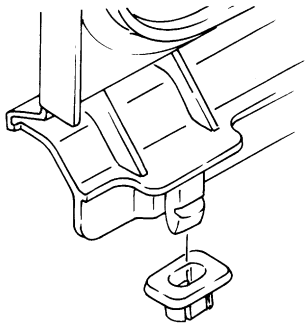
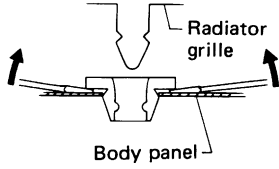
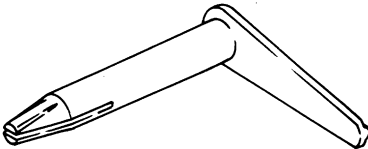
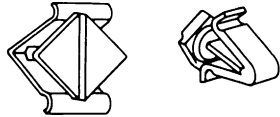
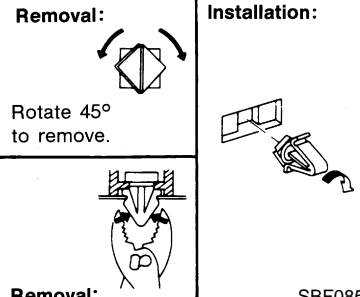
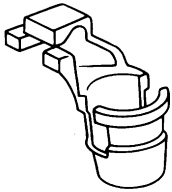
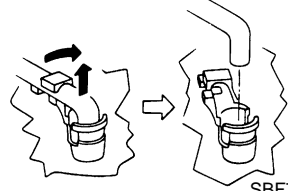
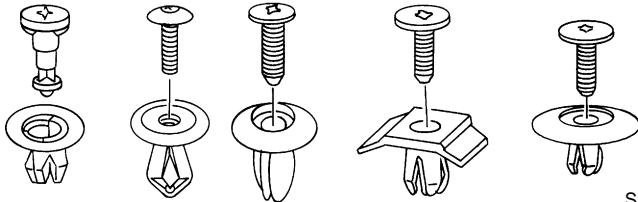
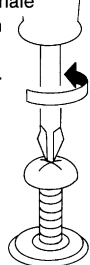
Symbol No.	Shapes	Removal & Installation
CG104		<p><b>Removal:</b> Remove by bending up with flat-bladed screwdrivers.</p> 
CE114		<p>—</p>
CG101		<p><b>Removal:</b> Rotate 45° to remove.</p> <p><b>Installation:</b></p> 
CR103		<p><b>Removal:</b> Holder portion of clip must be spread out to remove rod.</p> 
CS101		<p><b>Removal:</b></p> <ol style="list-style-type: none"> <li>Screw out with a Phillips screwdriver.</li> <li>Remove female portion with flat-bladed screwdriver.</li> </ol> 

GI  
MA  
EM  
LC  
EC  
FE  
CL  
MT  
AT  
TF  
PD  
AX  
SU  
BR  
ST  
RS  
BT  
HA  
SC  
EL  
IDX

## BODY FRONT END

Removal and Installation

---

### Removal and Installation

NGBT0004

- When removing or installing hood, place a cloth or other padding on hood. This prevents vehicle body from being scratched.
- Bumper fascia is made of plastic. Do not use excessive force and be sure to keep oil away from it.
- Hood adjustment: Adjust at hinge portion.
- Hood lock adjustment: After adjusting, check hood lock control operation. Apply a coat of grease to hood locks engaging mechanism.
- Hood opener: Do not attempt to bend cable forcibly. Doing so increases effort required to unlock hood.

### FRONT BUMPER ASSEMBLY

NGBT0004S01

1. Remove screws securing left and right combination lamps and remove the lamps. **A**
2. Remove clips securing front grille and remove the front grille. **B**
3. Remove bolts securing left and right bumper stays. **C**
4. Remove bolts securing left and right bumper side brackets. **D**
5. Remove bolts securing left and right bumper from bumper brackets. **E**
6. Remove bumper assembly.
7. Separate bumper assembly.

# BODY FRONT END

Removal and Installation (Cont'd)

SEC. 261 • 620 • 650

## Hood lock adjustment

- Adjust hood so that hood primary lock meshes at a position 1 to 1.5 mm (0.039 to 0.059 in) lower than fender.
- After hood lock adjustment, adjust bumper rubber.
- When securing hood lock, ensure it does not tilt. Striker must be positioned at the center of hood primary lock.
- After adjustment, ensure that hood primary and secondary lock operate properly.

## Hood lock secondary latch hooking length

More than 5.0 mm (0.197 in)

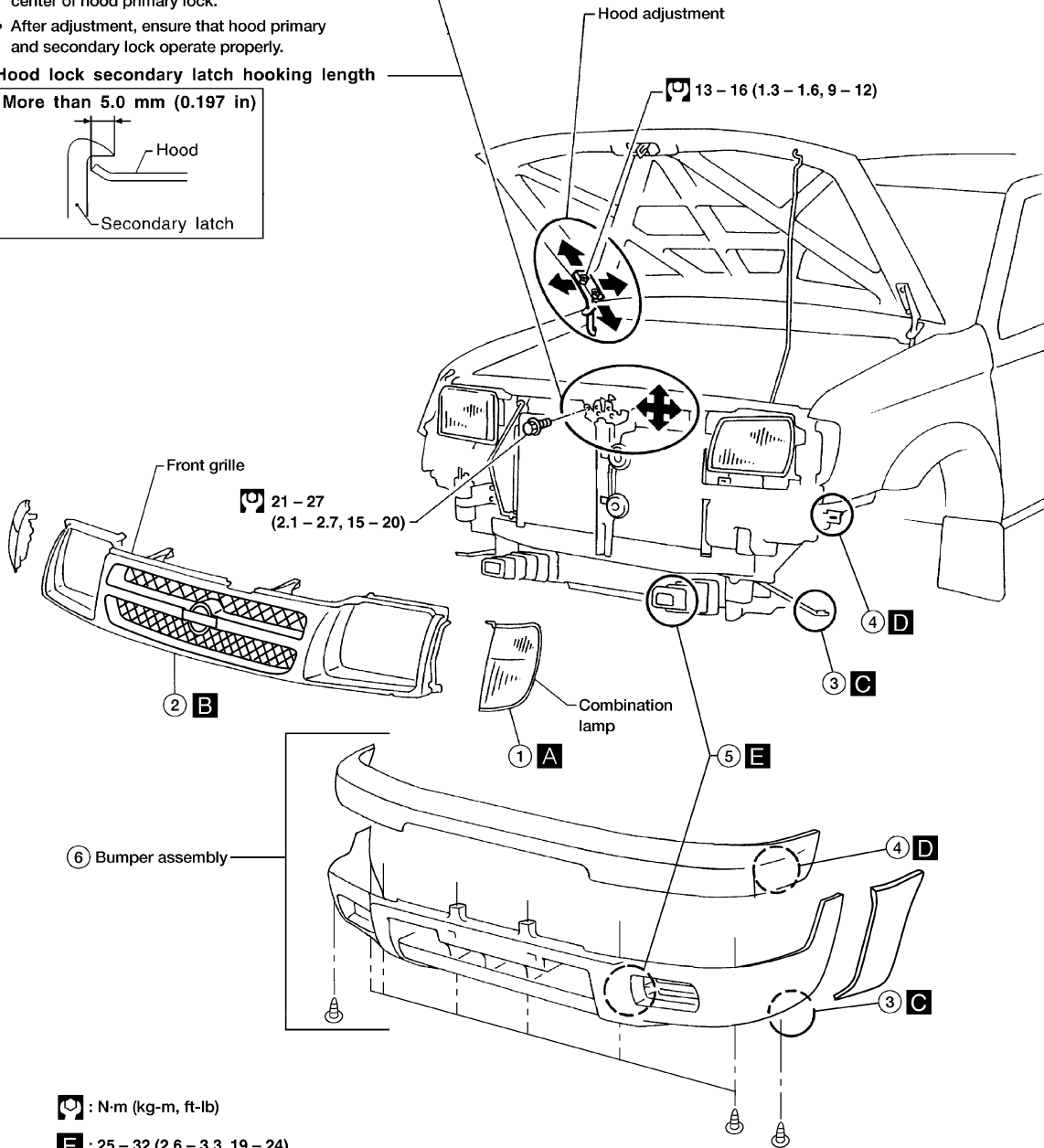
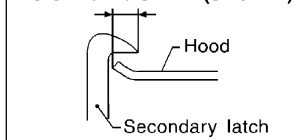

GI

MA

EM

LC

EC

FE

CL

MT

AT

TF

PD

AX

SU

BR

ST

RS

BT

HA

SC

WBT112

EL

IDX

# BODY FRONT END

Removal and Installation (Cont'd)

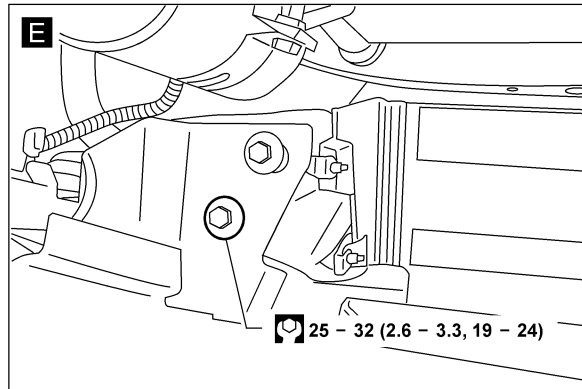
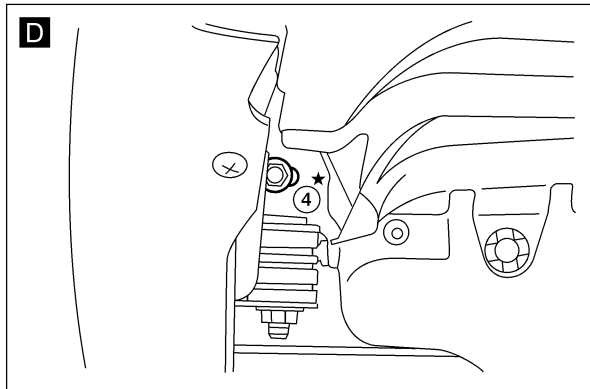
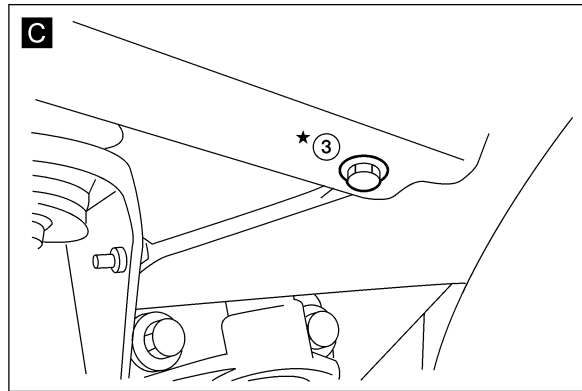
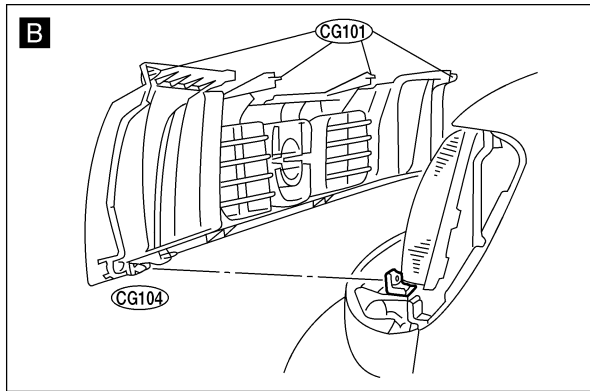
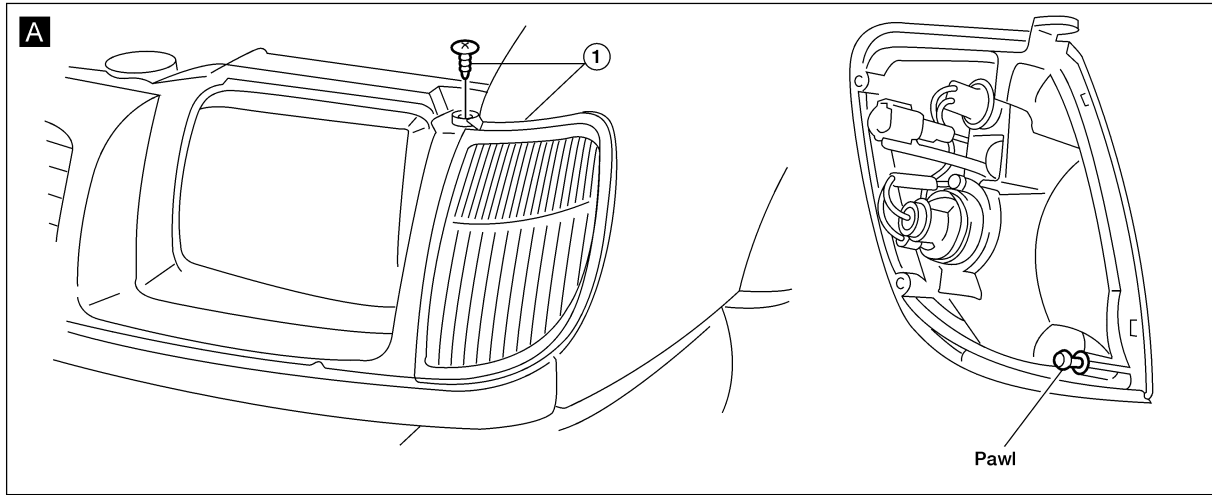

$\boxed{\text{N}}$  : N-m (kg-m, ft-lb)

★ : Bumper assembly mounting bolts

ABT450

# BODY REAR END AND OPENER

Removal and Installation

## Removal and Installation

- Bumper fascia is made of plastic. Do not use excessive force and be sure to keep oil away from it. NGBT0005
- Back door lock system adjustment: Adjust lock and striker so that they are in the center. After adjustment, check back door lock operation. **GI**

### REAR BUMPER ASSEMBLY

1. Remove screws securing left and right bumper side. **F**
2. Remove bumper side left and right.
3. Remove nuts securing rear bumper. **E**
4. Remove rear bumper.

NGBT0005S01

MA

EM

LC

EC

FE

CL

MT

AT

TF

PD

AX

SU

BR

ST

RS

**BT**

HA

SC

EL

IDX

# BODY REAR END AND OPENER

Removal and Installation (Cont'd)

SEC. 850 • 900 • 905

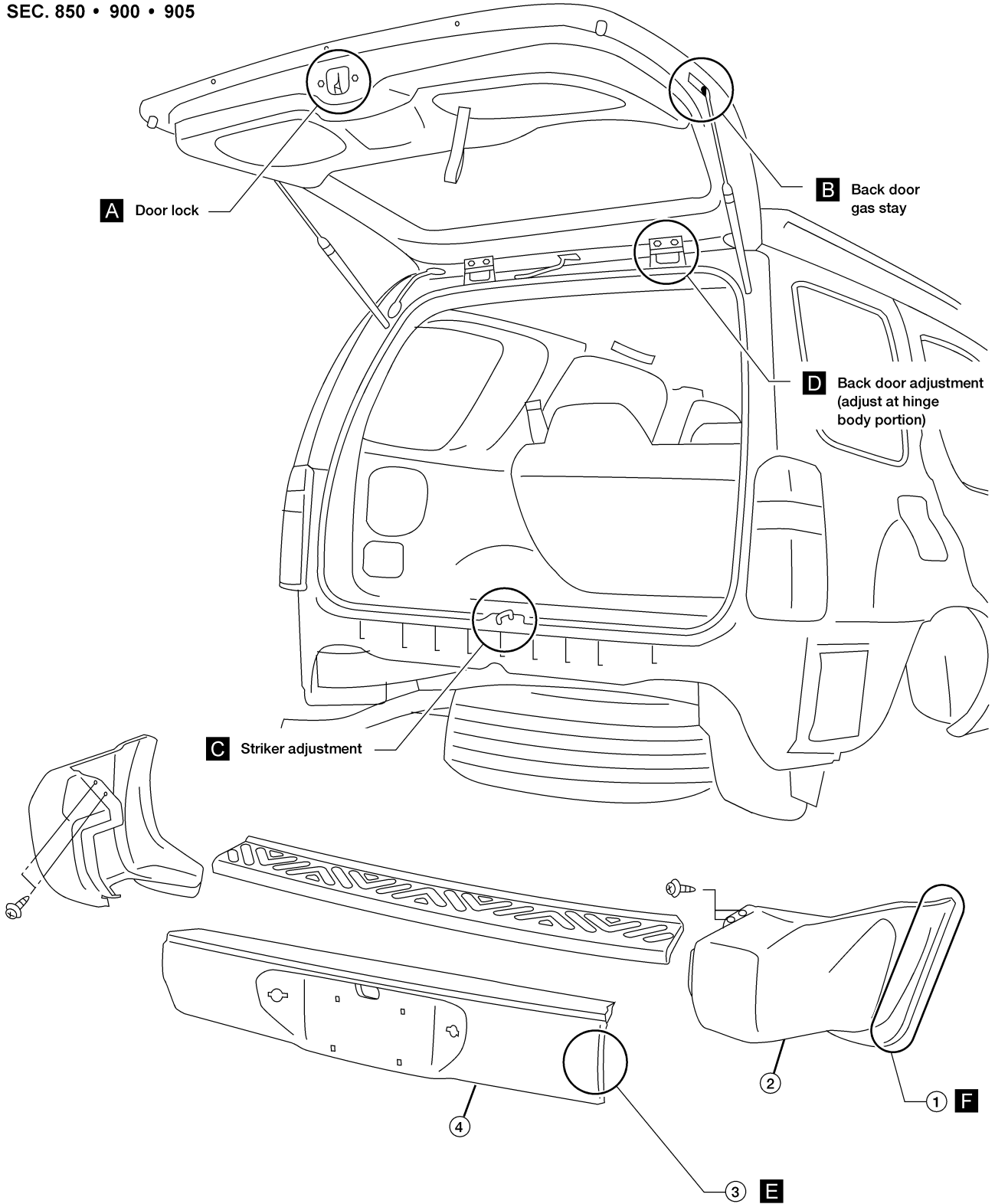

ABT443



# BODY REAR END AND OPENER

Removal and Installation (Cont'd)

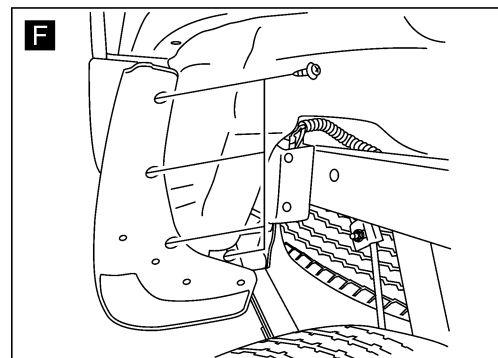
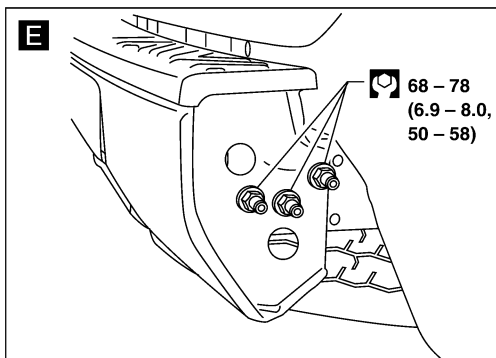
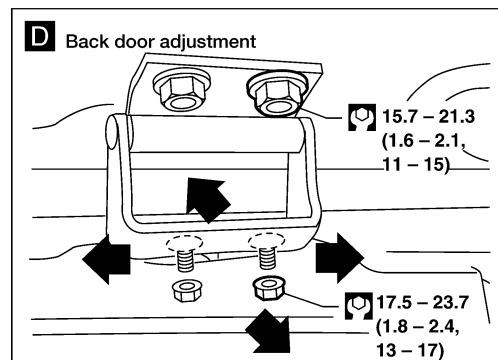
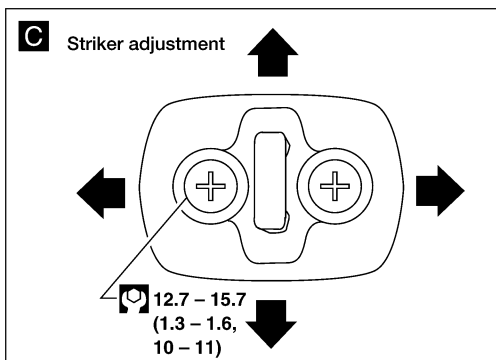
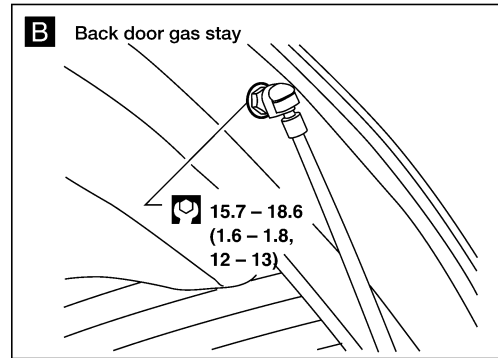
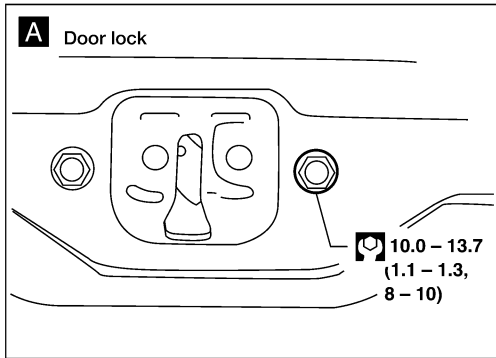

GI

MA

EM

LC

EC

FE

CL

MT

AT

TF

PD

AX

SU

BR

ST

RS

**BT**

HA

SC

EL

IDX

: N·m (kg-m, ft-lb)

WBT192

# FRONT DOOR

Overhaul

## Overhaul

NGBT0006

- For removal of door trim, refer to "Removal and Installation", BT-27.
- After adjusting door or door lock, check door lock operation.

SEC. 800•803•805

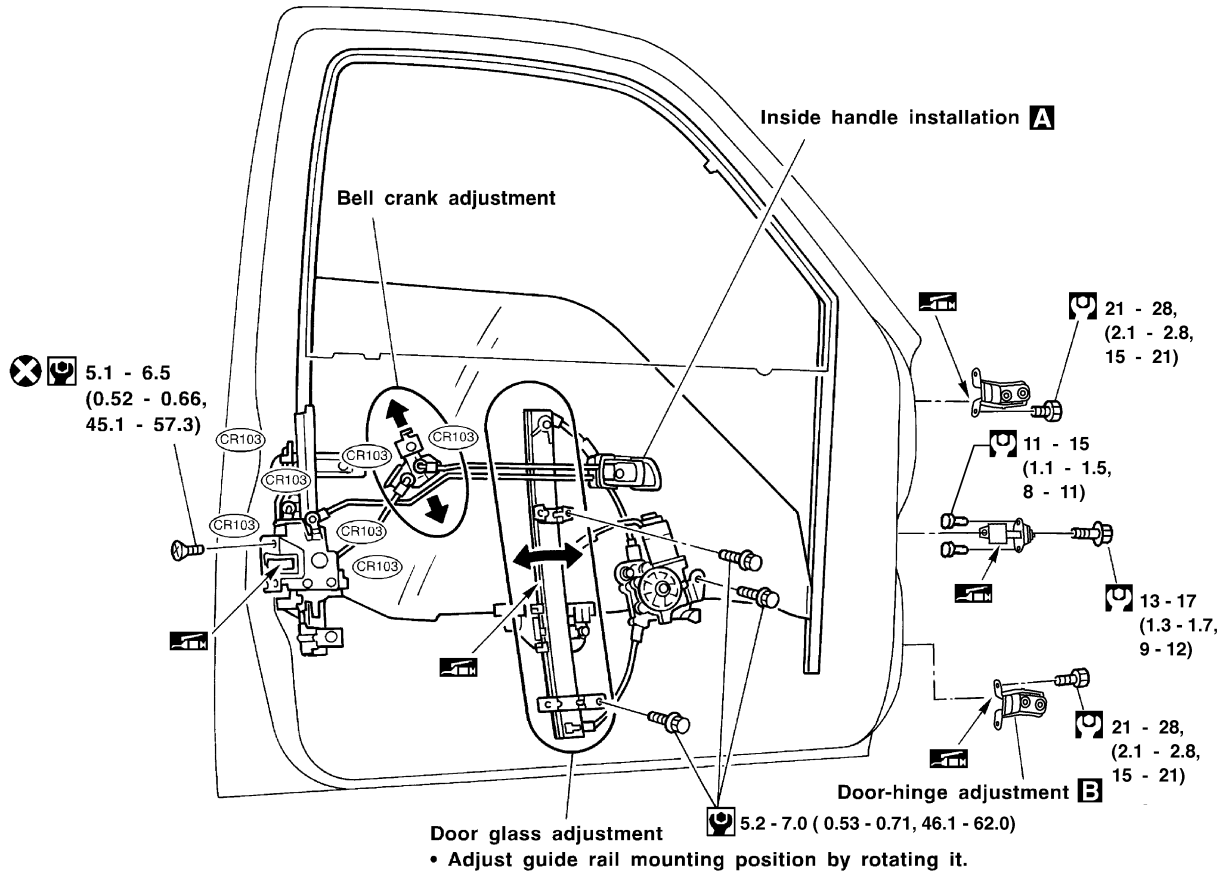

### A Bell crank adjustment

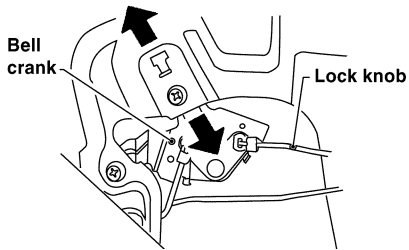

Lock door after setting door lock assembly and inside handle in position. Move bell crank in direction of arrow (shown in figure at left) to take up knob free play, and secure with bolts.

### B Door-hinge adjustment

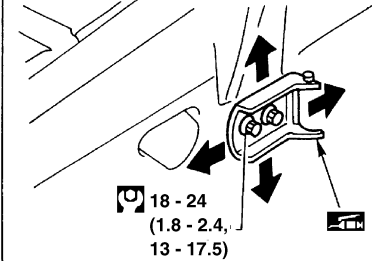

### Striker adjustment

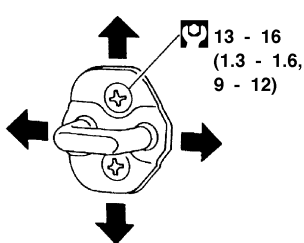

: N•m (kg-m, in-lb)  
 : N•m (kg-m, ft-lb)

ABT481

# REAR DOOR

Overhaul

## Overhaul

NGBT0023

SEC. 820 • 823 • 825

GI

MA

EM

LC

EC

FE

CL

MT

AT

TF

PD

AX

SU

BR

ST

RS

BT

HA

SC

EL

IDX

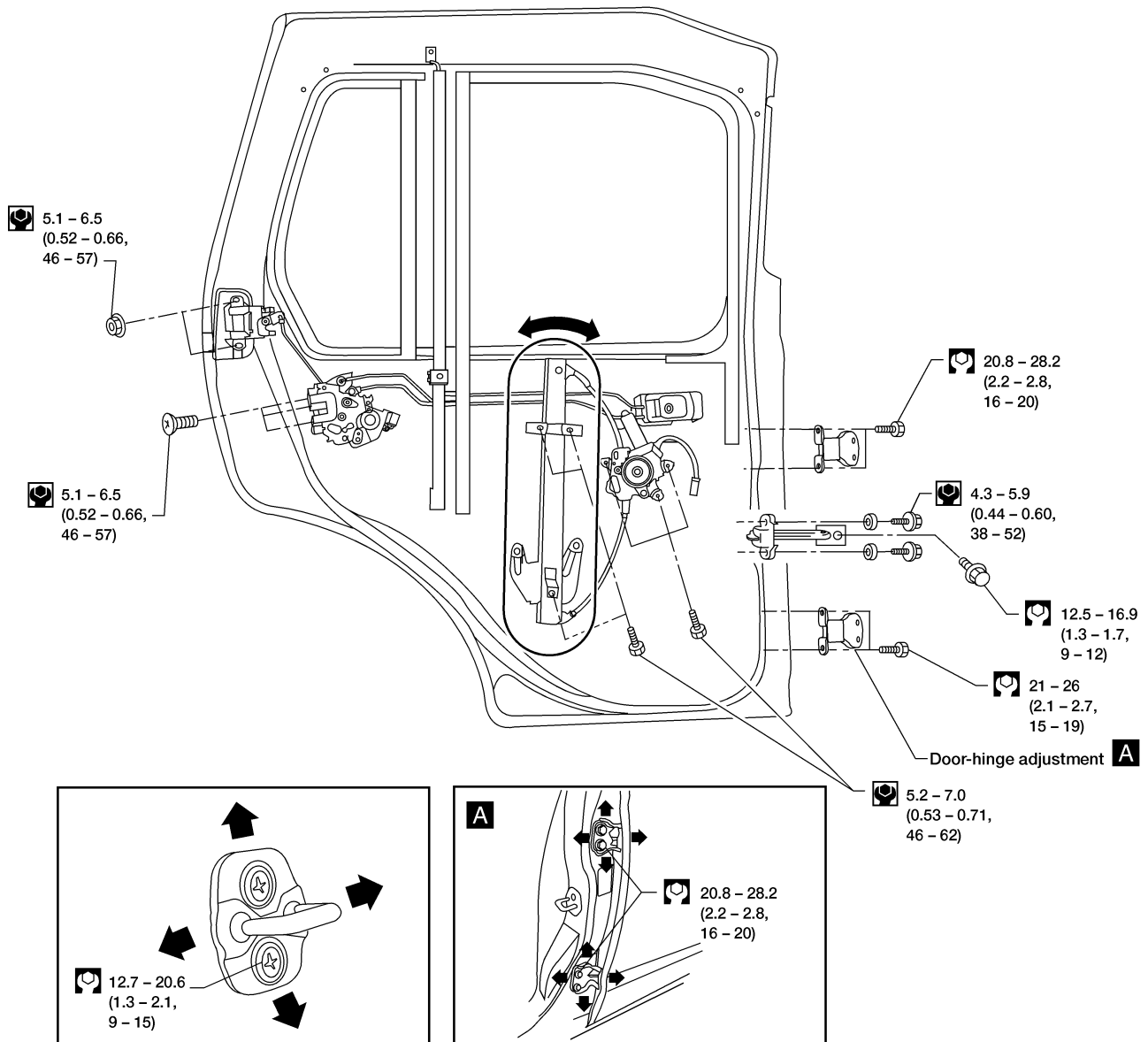

: N·m (kg·m, in·lb)

: N·m (kg·m, ft·lb)

WBT080

# INSTRUMENT PANEL ASSEMBLY

Removal and Installation

## Removal and Installation

NGBT0008

### CAUTION:

- Disconnect both terminals from battery in advance.
- Disconnect air bag module connectors in advance.
- Be careful not to scratch finishers and other parts.
- Never tamper with or force air bag lid open, as this may adversely affect air bag performance.



WBT156

\*1 RS-18

# INSTRUMENT PANEL ASSEMBLY

Removal and Installation (Cont'd)

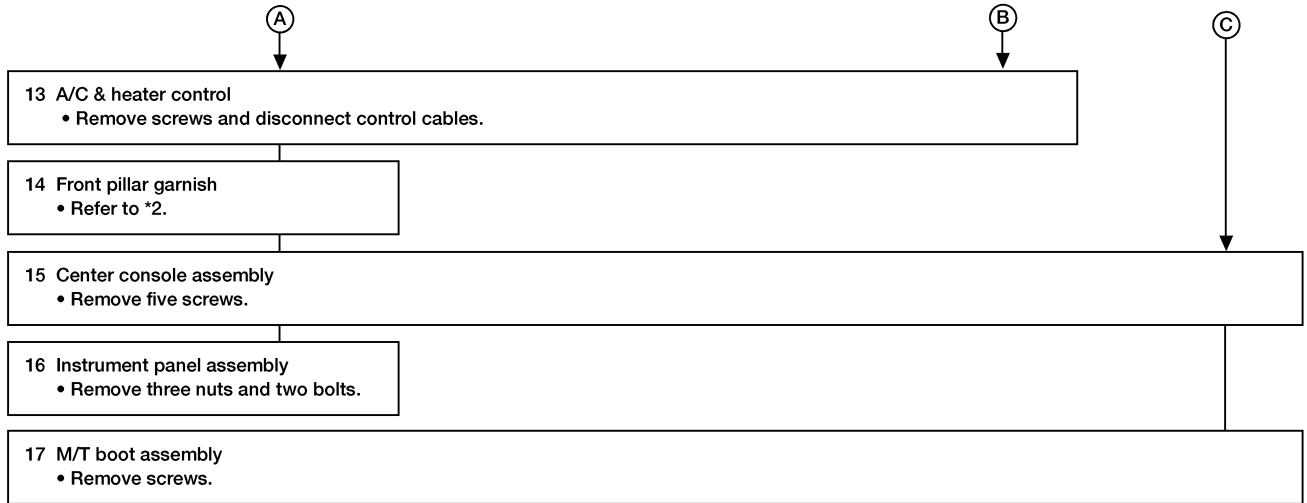

GI

MA

EM

LC

EC

FE

WBT106 CL

\*2 BT-24

MT

AT

TF

PD

AX

SU

BR

ST

RS

**BT**

HA

SC

EL

IDX

# INSTRUMENT PANEL ASSEMBLY

Removal and Installation (Cont'd)

SEC. 272 • 280 • 680 • 685 • 969

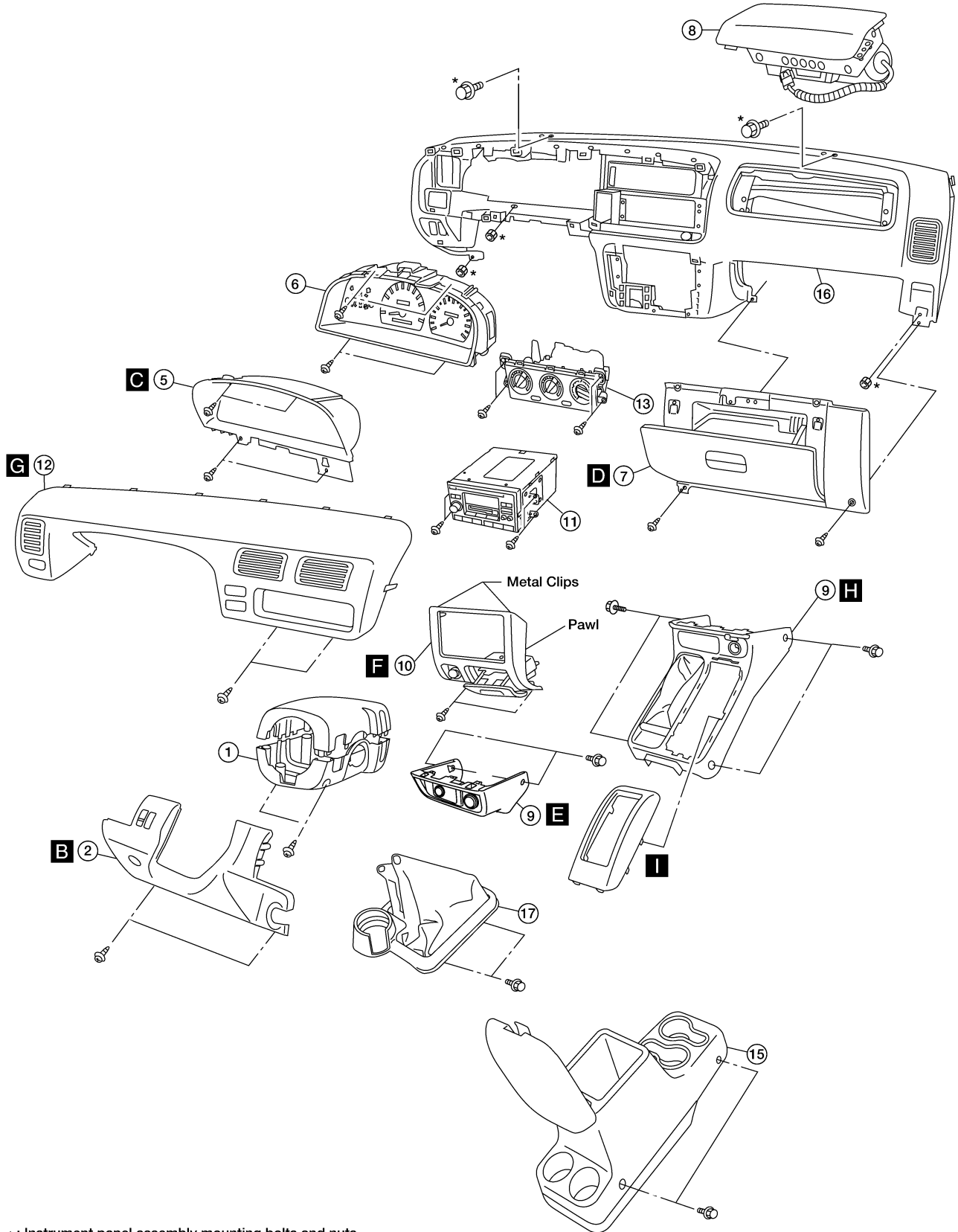

\* : Instrument panel assembly mounting bolts and nuts.

WBT107

# INSTRUMENT PANEL ASSEMBLY

Removal and Installation (Cont'd)

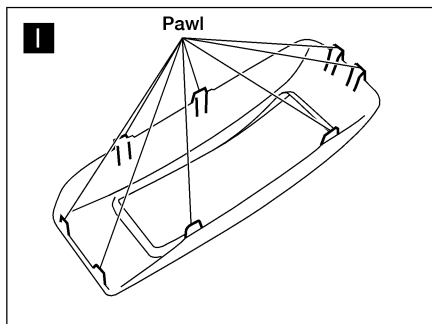
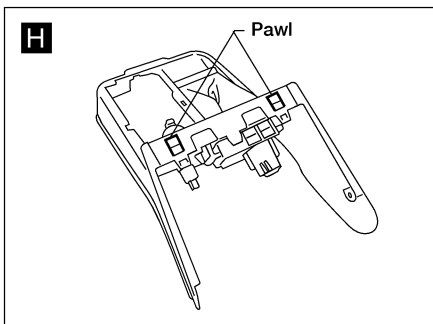
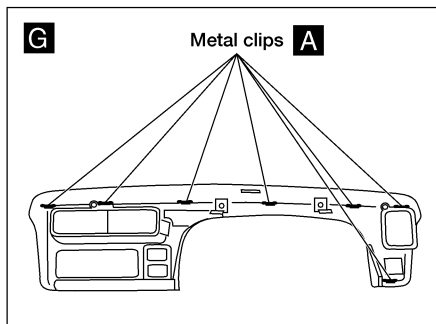
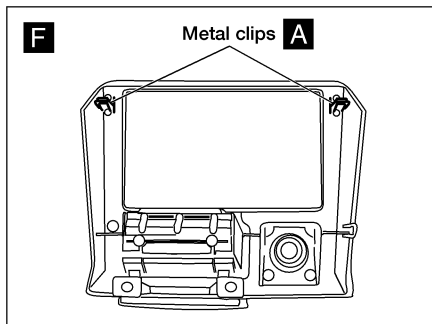
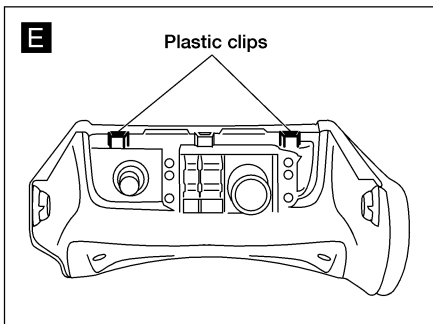
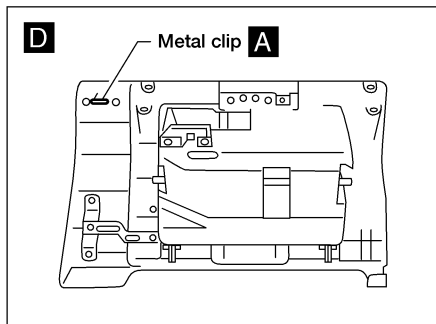
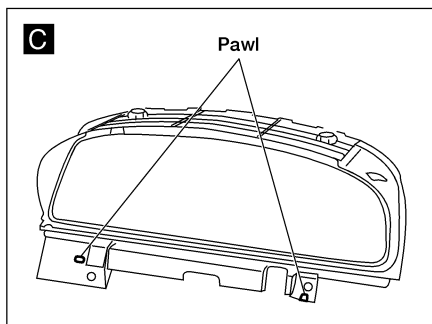
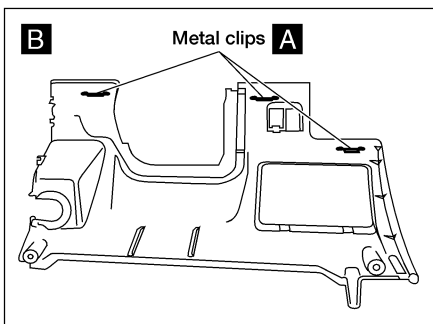
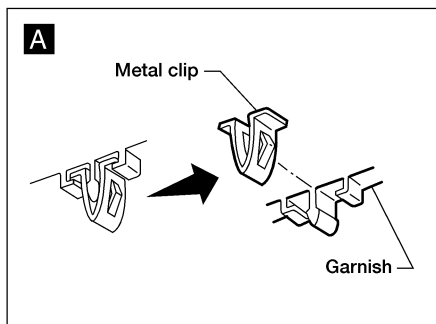

GI  
MA  
EM  
LC  
EC  
FE  
CL  
MT  
AT  
TF  
PD  
AX  
SU  
BR  
ST  
RS  
BT  
HA  
SC  
EL  
IDX

WBT108

# SIDE AND FLOOR TRIM

Removal and Installation

---

## Removal and Installation

NGBT0009

**CAUTION:**

**Wrap the tip of flat-bladed screwdriver with a cloth when removing metal clips from garnishes.**

1. Remove front and rear seats . Refer to "Removal and Installation", BT-37 or 38.
2. Remove front and rear kicking plates.
3. Remove dash side lower finishes.
4. Remove front and rear body side welts.
5. Remove front pillar garnishes. **B**
6. Remove center pillar lower garnishes. **C**
7. Remove center pillar upper garnishes. **D**
8. Remove rear gate kicking plate.
9. Remove rear wheel well garnish.
10. Remove rear side lower garnishes. **E**
11. Remove rear side upper garnishes. **F**



# SIDE AND FLOOR TRIM

Removal and Installation (Cont'd)

SEC. 678 • 738 • 799 • 849

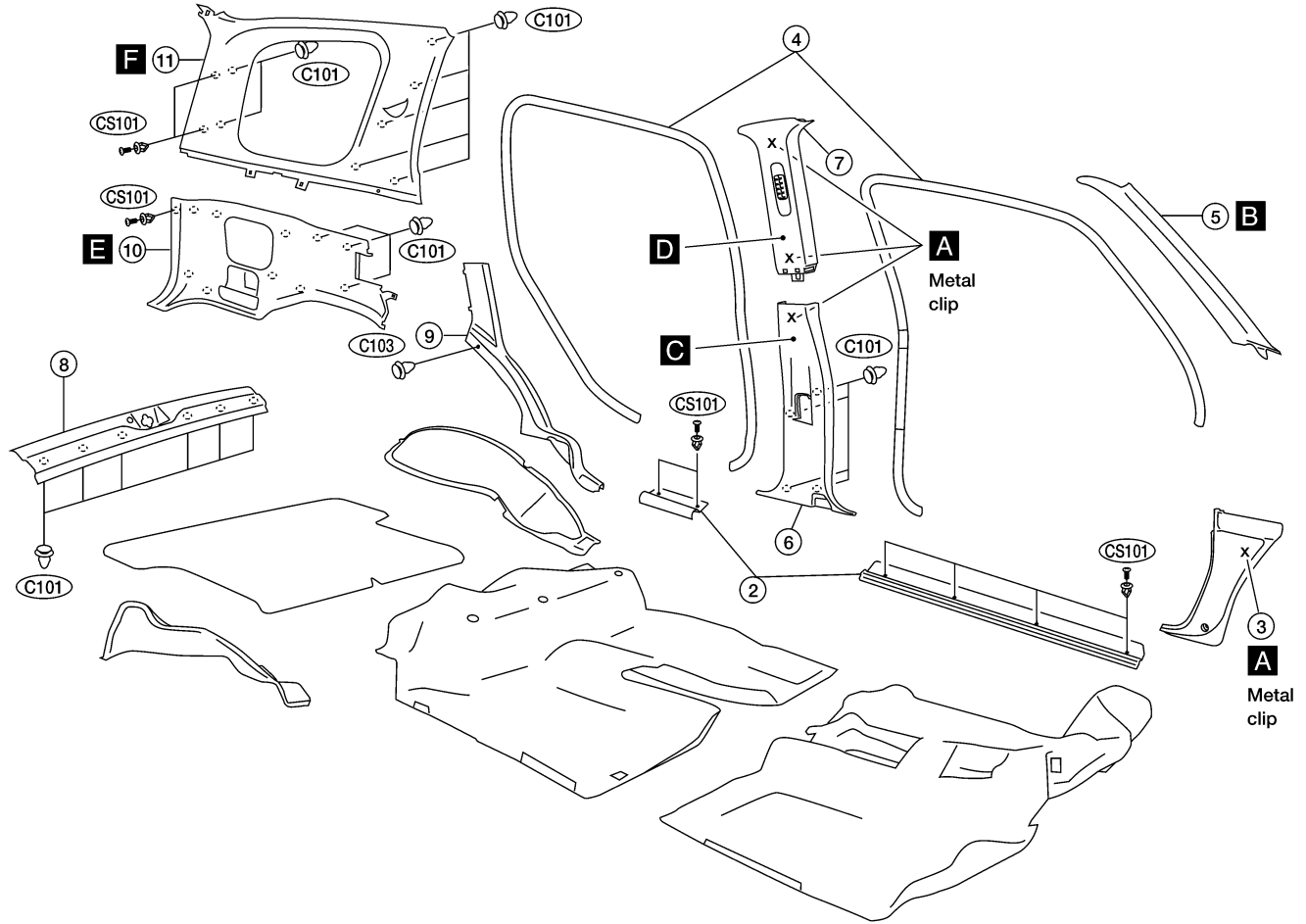

GI

MA

EM

LC

EC

FE

CL

MT

AT

TF

PD

AX

SU

BR

ST

RS

**BT**

HA

SC

EL

IDX

WBT124

# SIDE AND FLOOR TRIM

Removal and Installation (Cont'd)

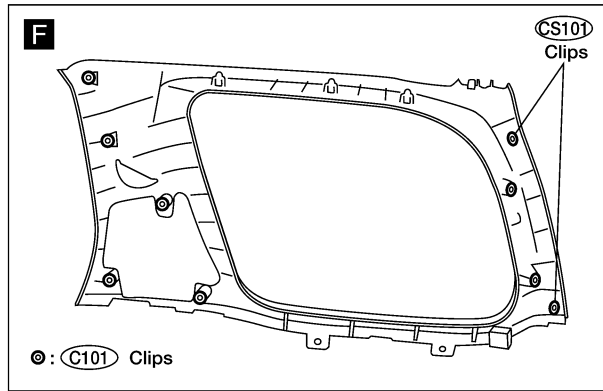
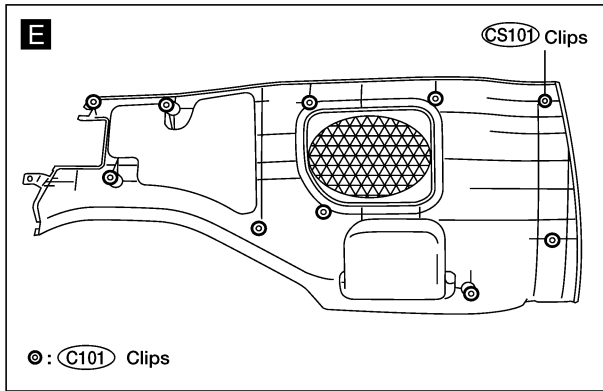
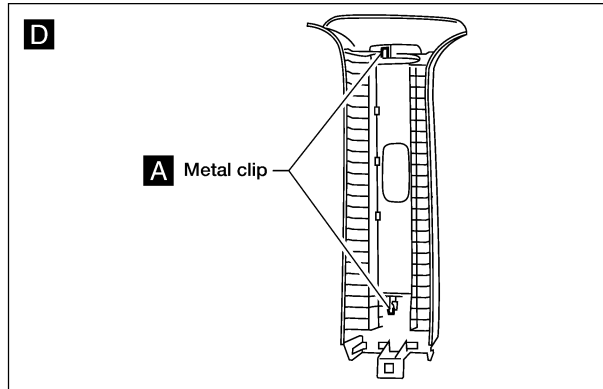
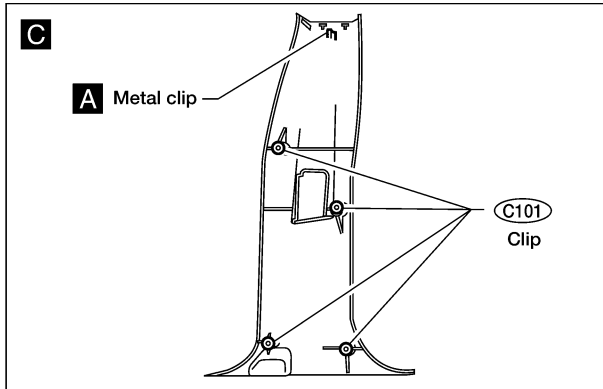
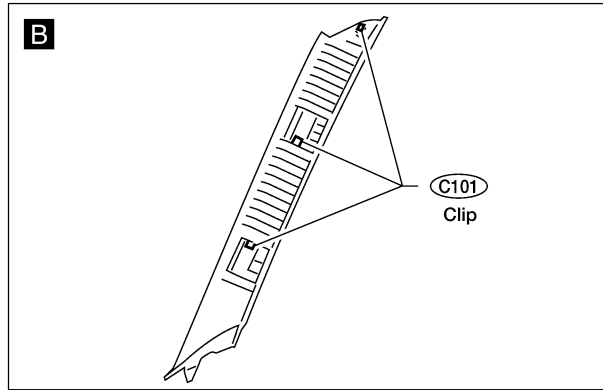
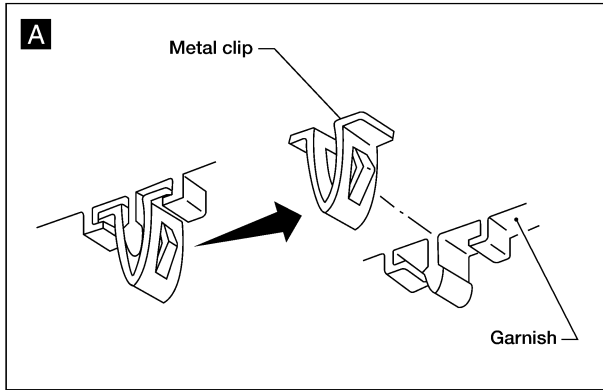

WBT125

## Removal and Installation

NGBT0010

### Door trim (Formed type)

Remove manual window regulator handle, if equipped.

1. Remove inside handle escutcheon. **A**
2. Remove door armrest. **B**
3. Remove screw securing door pull handle.
4. Remove power window switch, then disconnect the connector. **C D**
5. Remove two screws.
6. Remove clips securing door finisher.
7. Lift out door finisher.
8. Remove inside escutcheon.
9. Remove screw securing door pull handle.
10. Remove clips securing door finisher.
11. Lift out door finisher.

GI

MA

EM

LC

EC

FE

CL

MT

AT

TF

PD

AX

SU

BR

ST

RS

**BT**

HA

SC

EL

IDX

# DOOR TRIM

Removal and Installation (Cont'd)

SEC. 251 • 809 • 828

## Formed type (without power windows)

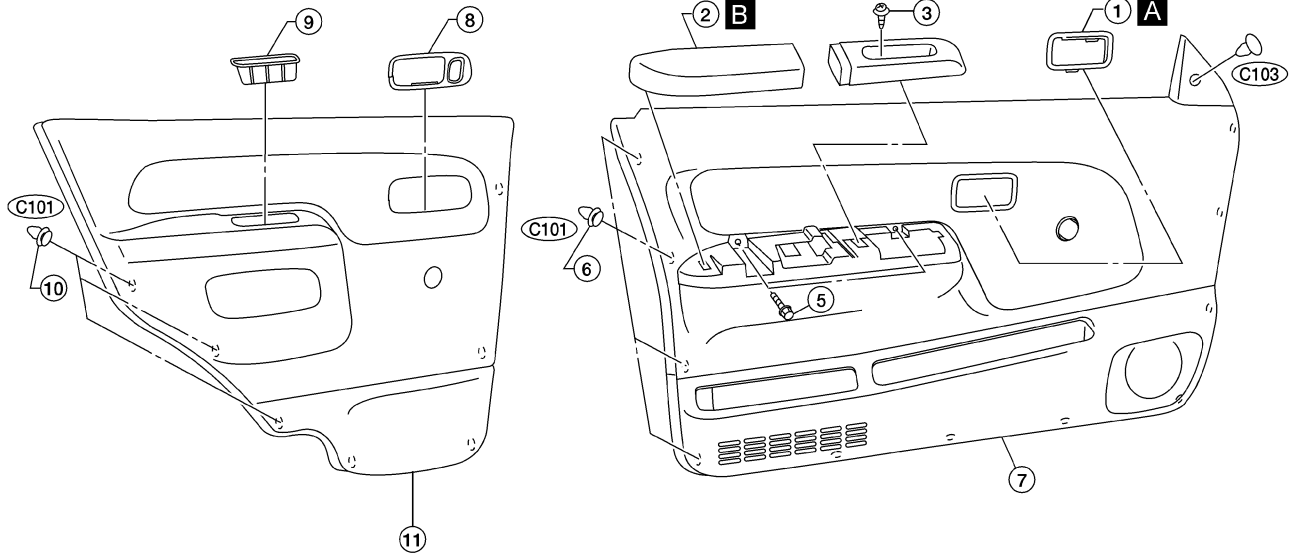

## Formed type (with power windows)

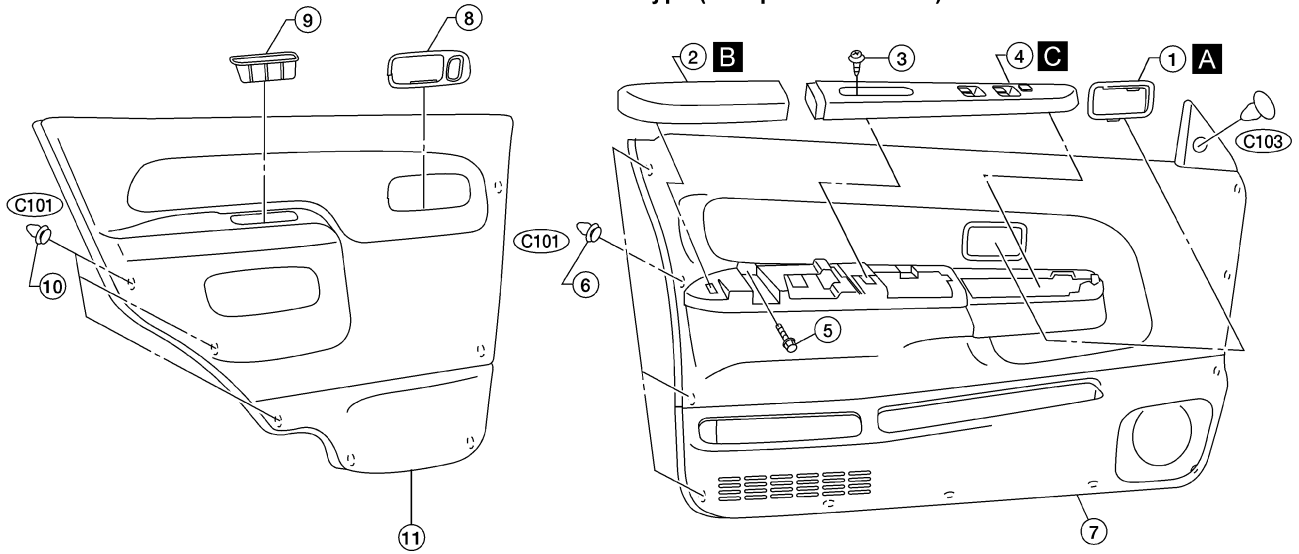

ABT447

# DOOR TRIM

Removal and Installation (Cont'd)

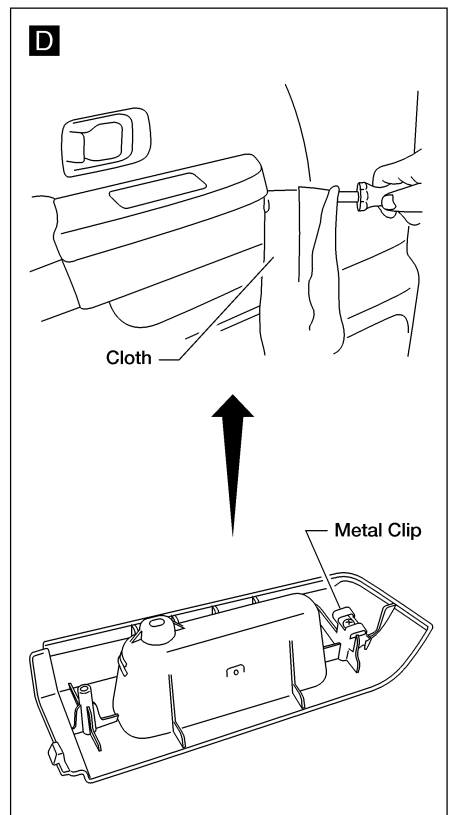
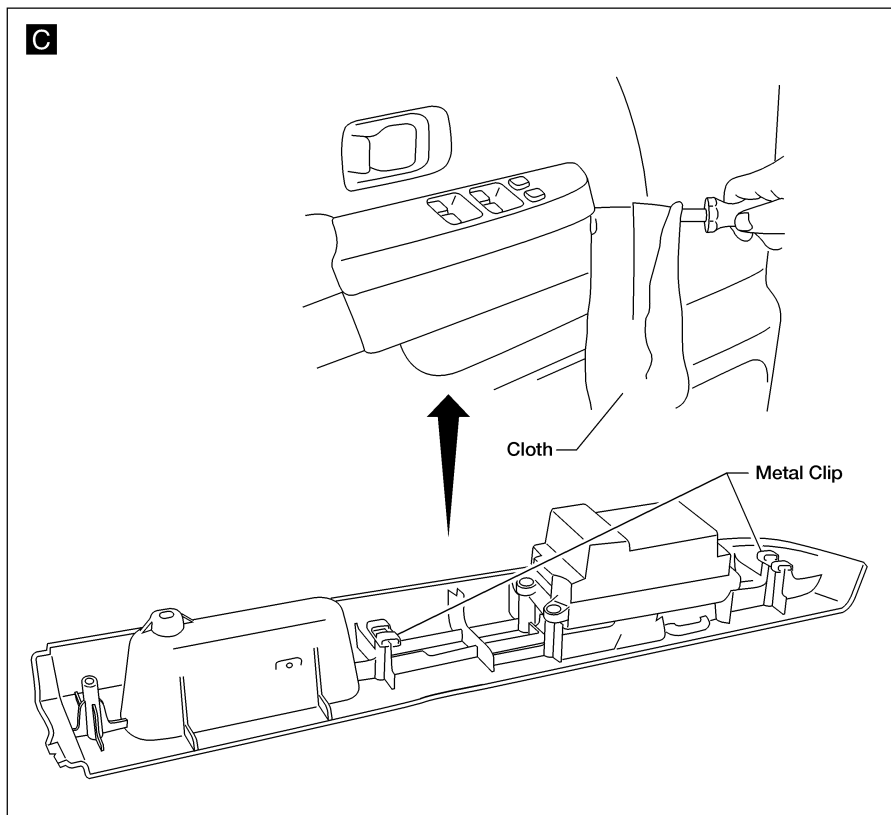
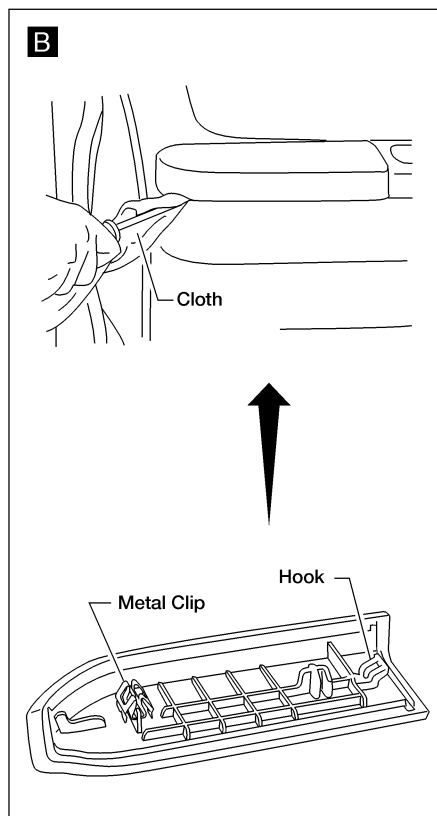
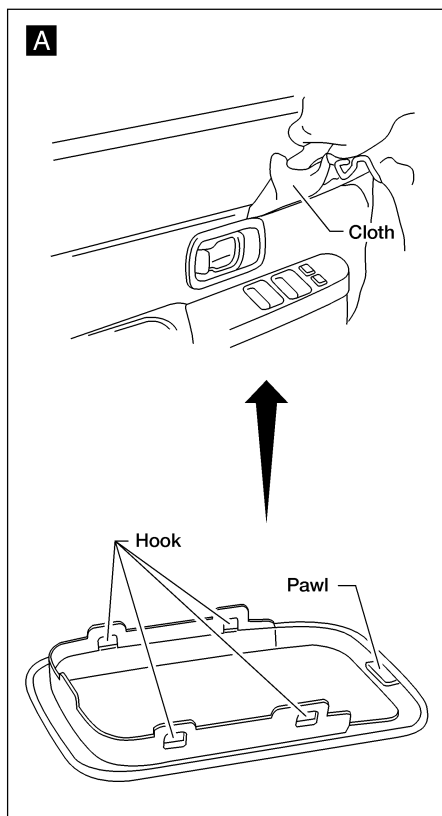

GI  
MA  
EM  
LC  
EC  
FE  
CL  
MT  
AT  
TF  
PD  
AX  
SU  
BR  
ST  
RS  
**BT**  
HA  
SC  
EL  
IDX

ABT299

# ROOF TRIM

Removal and Installation

## Removal and Installation

NGBT0011

1. Remove front and rear seats. Refer to "Removal and Installation", BT-37 or 38.
2. Remove front and rear seat belts. Refer to "SEAT BELTS", **RS-4** or **RS-5**.
3. Remove body side trim. Refer to "SIDE AND FLOOR TRIM", BT-24.
4. Remove sun visors.
5. Remove assist grips.
6. Remove interior lamp assembly and luggage room lamp assembly.
7. Remove clips securing headliner.
8. Remove coat hooks.
9. Remove sunroof welt.
10. Remove headliner.

SEC. 264 • 738 • 963 • 970

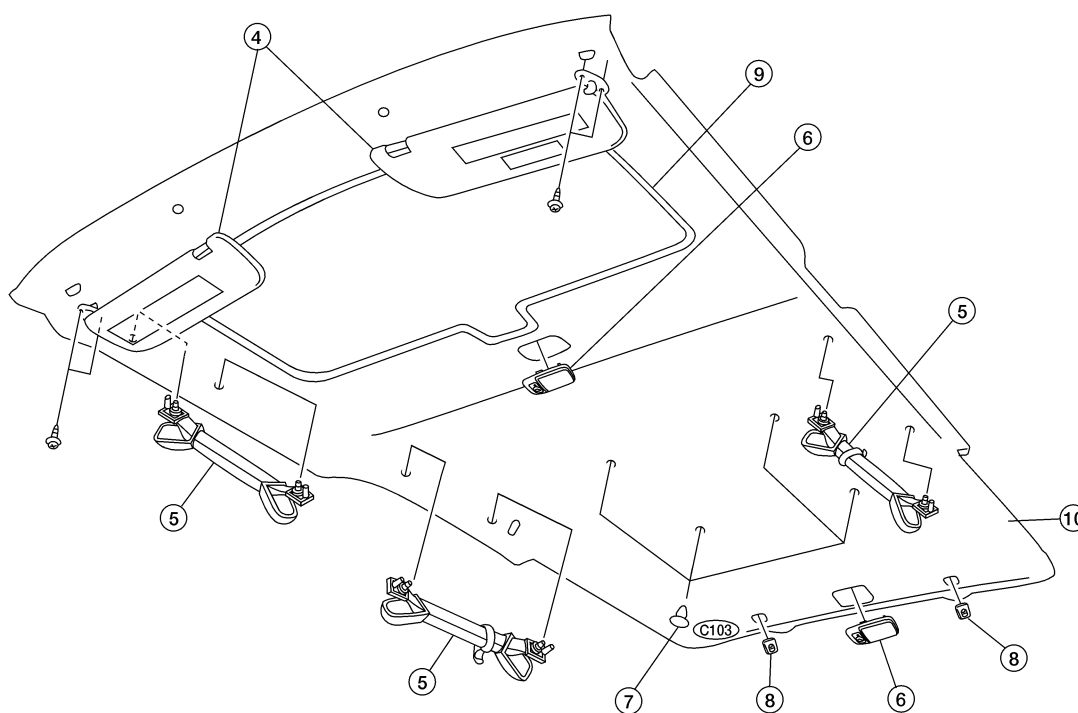

WBT081

# BACK DOOR TRIM

Removal and Installation

## Removal and Installation

1. Remove back door grip.
2. Remove back door finisher assembly.

NGBT0024

SEC. 268 • 909

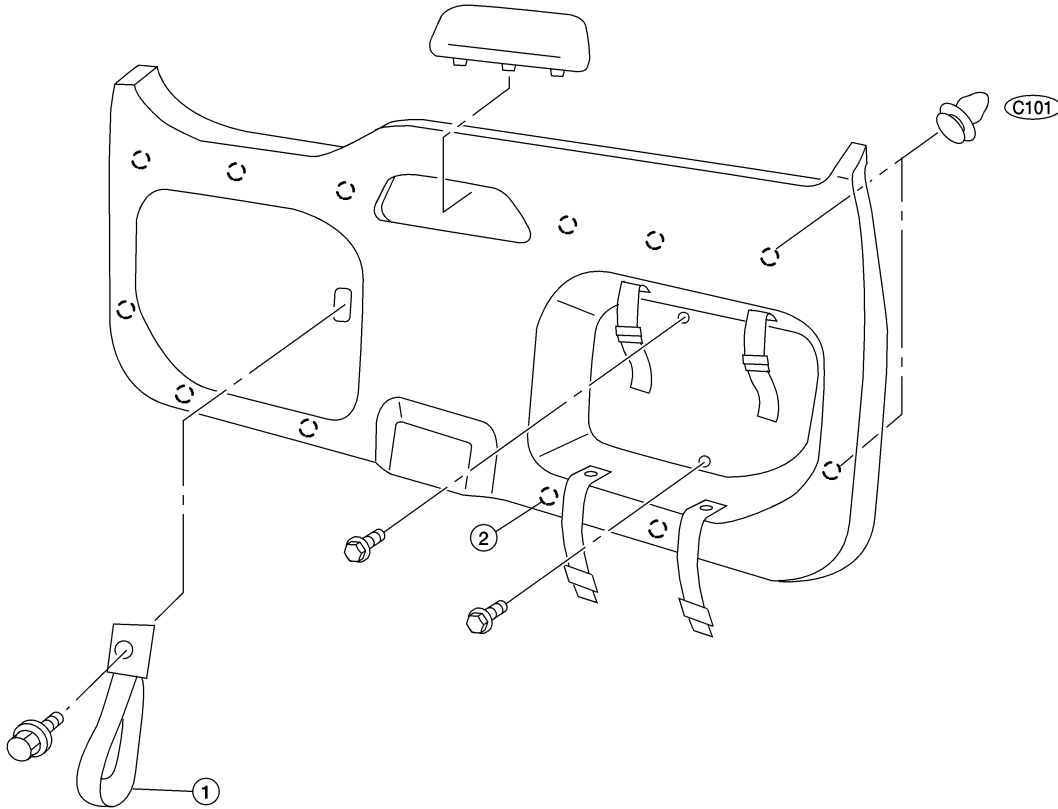

GI

MA

EM

LC

EC

FE

CL

MT

AT

TF

PD

AX

SU

BR

ST

RS

WBT082

**BT**

HA

SC

EL

IDX

# EXTERIOR

Removal and Installation

## Removal and Installation

NGBT0013

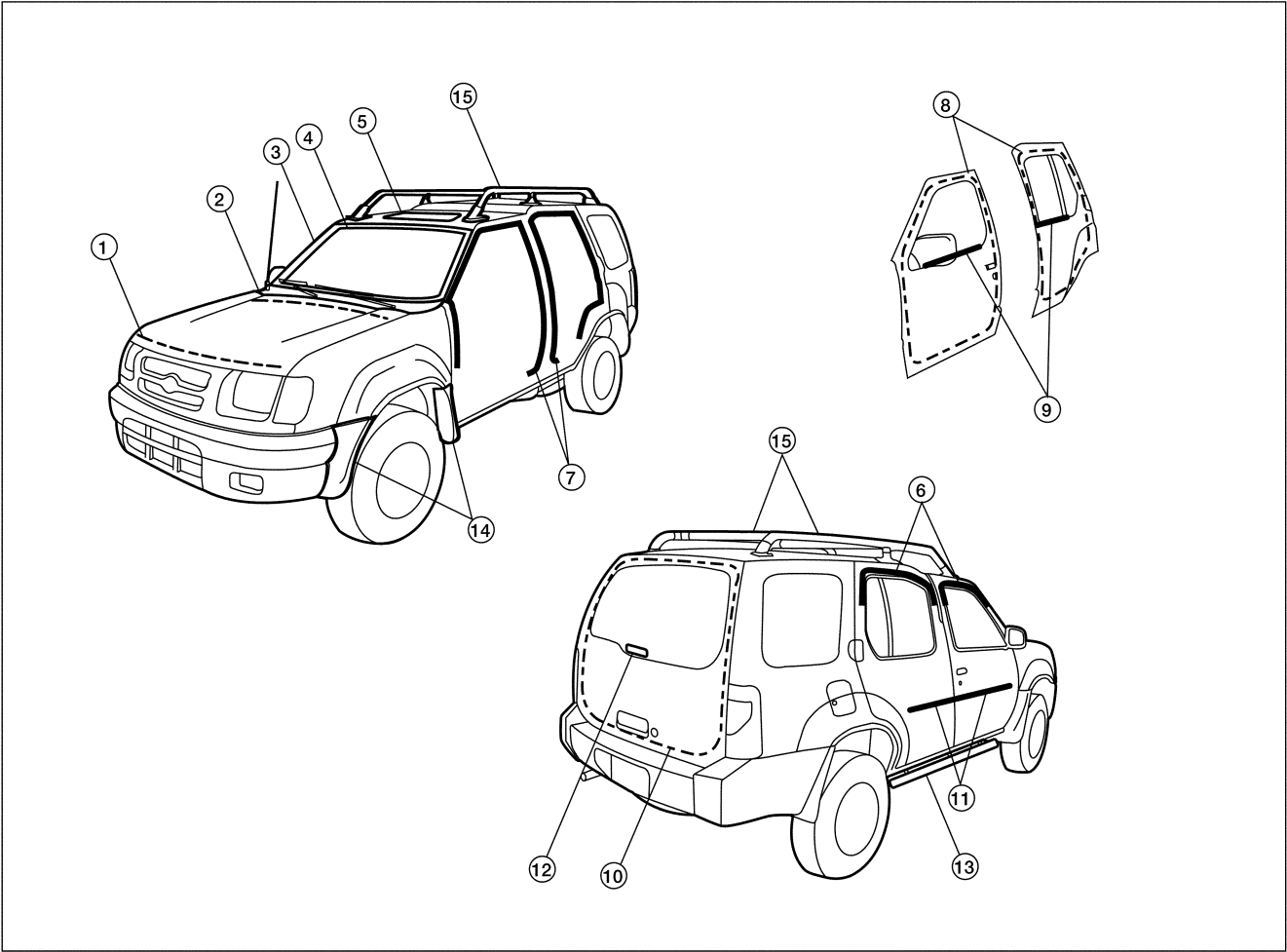

### ① Hood front sealing rubber

SEC. 650

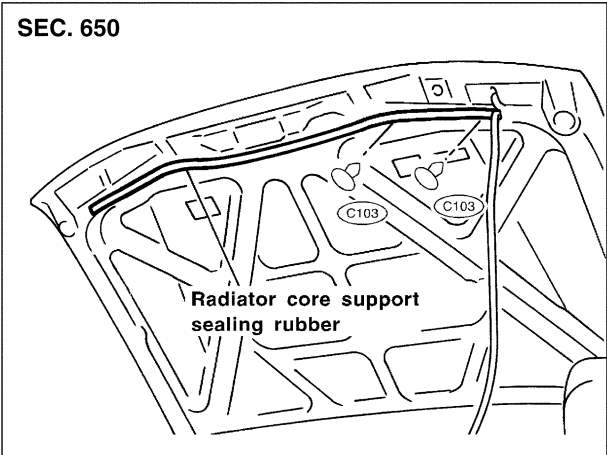

### ② Cowl top seal and cowl top grille

SEC. 660

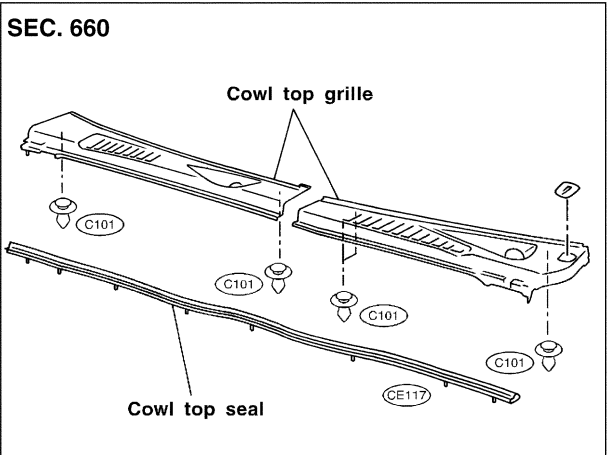

ABT453



### ③ Windshield side molding

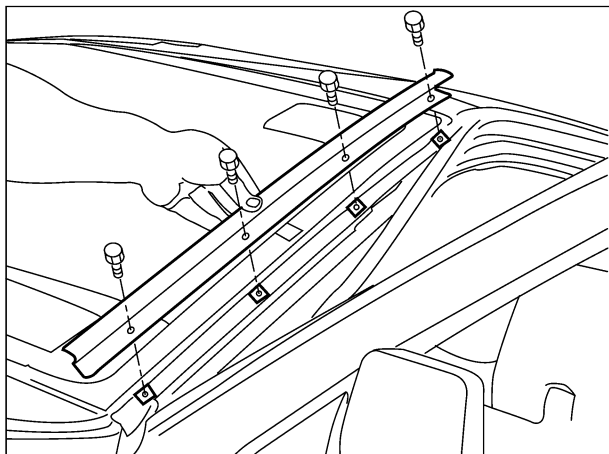

### ⑤ Sunroof weatherstrip and lid protector

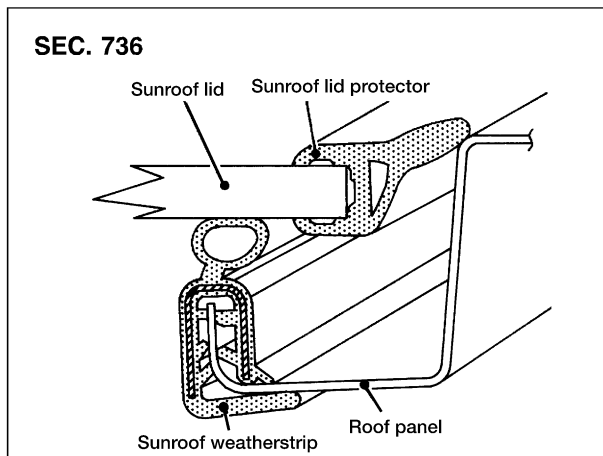

### ④ Windshield upper molding

**SEC. 720**

1. Remove windshield.
2. Remove old urethane adhesive from panel surface.
3. Set molding fastener and apply primer to body panel, and apply urethane adhesive to glass.

Apply urethane adhesive evenly.

7 - 9 (0.28 - 0.35)  
12 - 14 (0.47 - 0.55)

Open cell foam dam Glass

Unit: mm (in)

Molding Glass Roof

4. Install molding by aligning the molding mark located on center with vehicle center. Be sure to install tightly so that there is no gap around the corner.

### ⑥ Drip weatherstrip

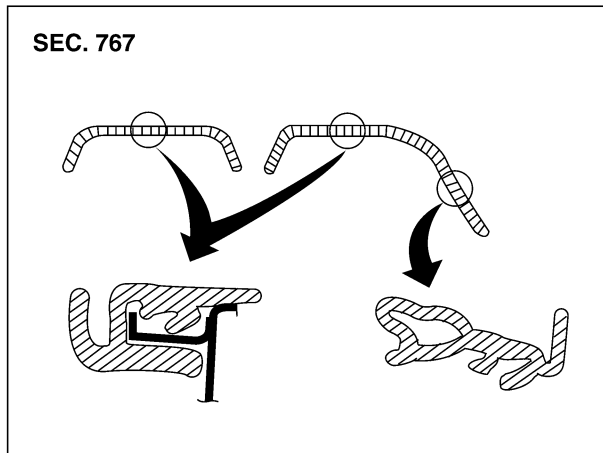

### ⑦ Body side welt

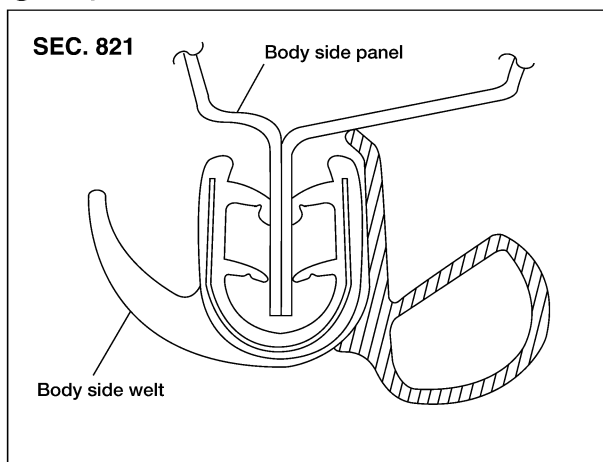

GI  
MA  
EM  
LC  
EC  
FE  
CL  
MT  
AT  
TF  
PD  
AX  
SU  
BR  
ST  
RS  
BT  
HA  
SC  
EL  
IDX

# EXTERIOR

Removal and Installation (Cont'd)

### 8 Door weatherstrip

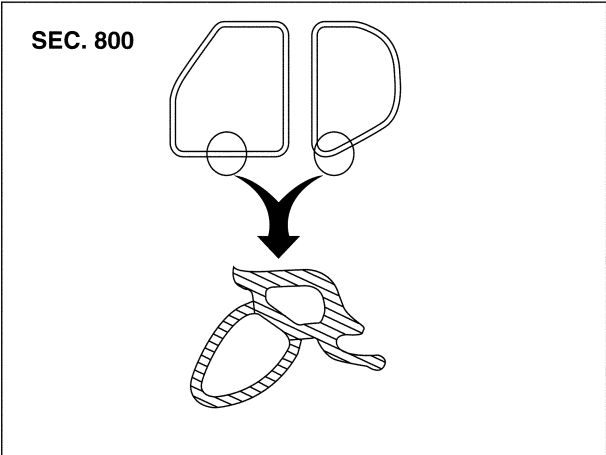

### 10 Back door weatherstrip

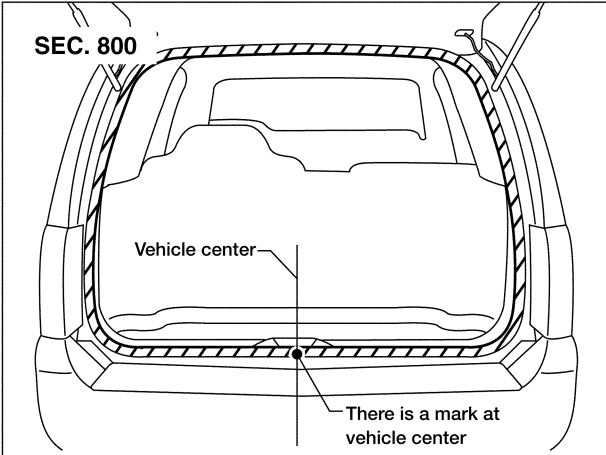

### 9 Door outside molding

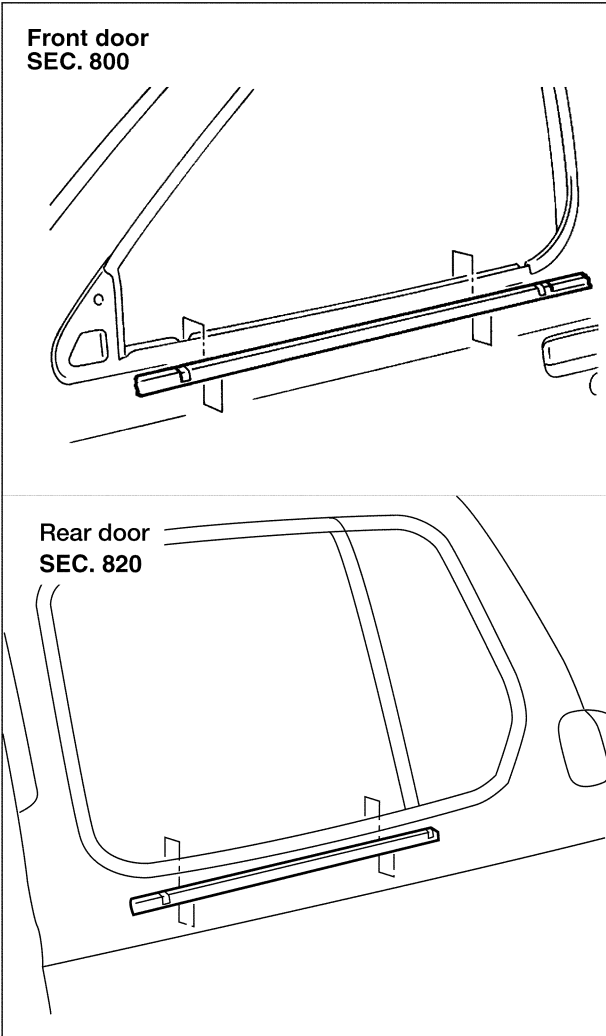

### 11 Side guard molding

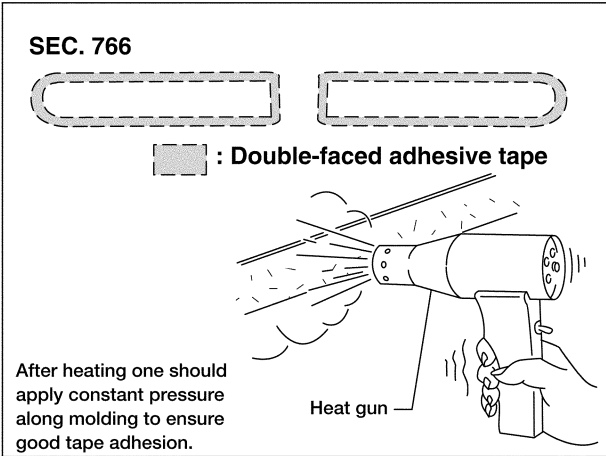

### 12 High-mounted stop lamp

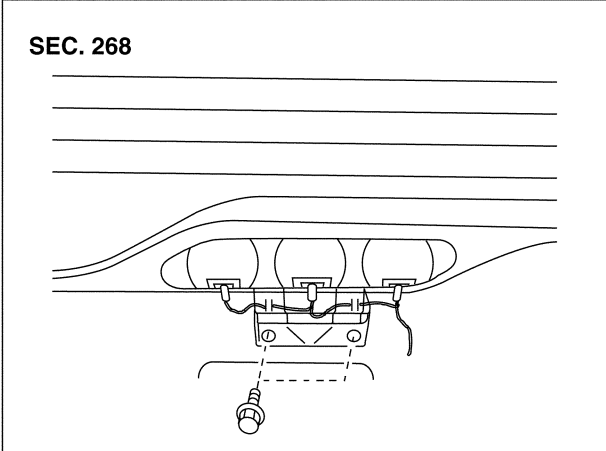

# EXTERIOR

Removal and Installation (Cont'd)

## 13 Side step

SEC. 767

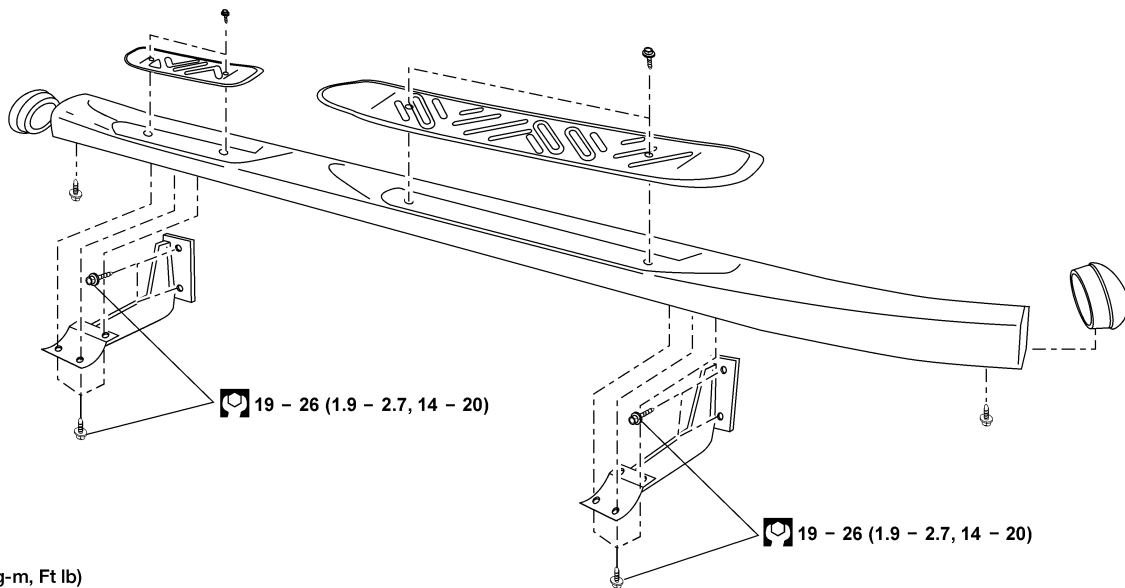

## 14 Over fender

SEC. 630 • 780

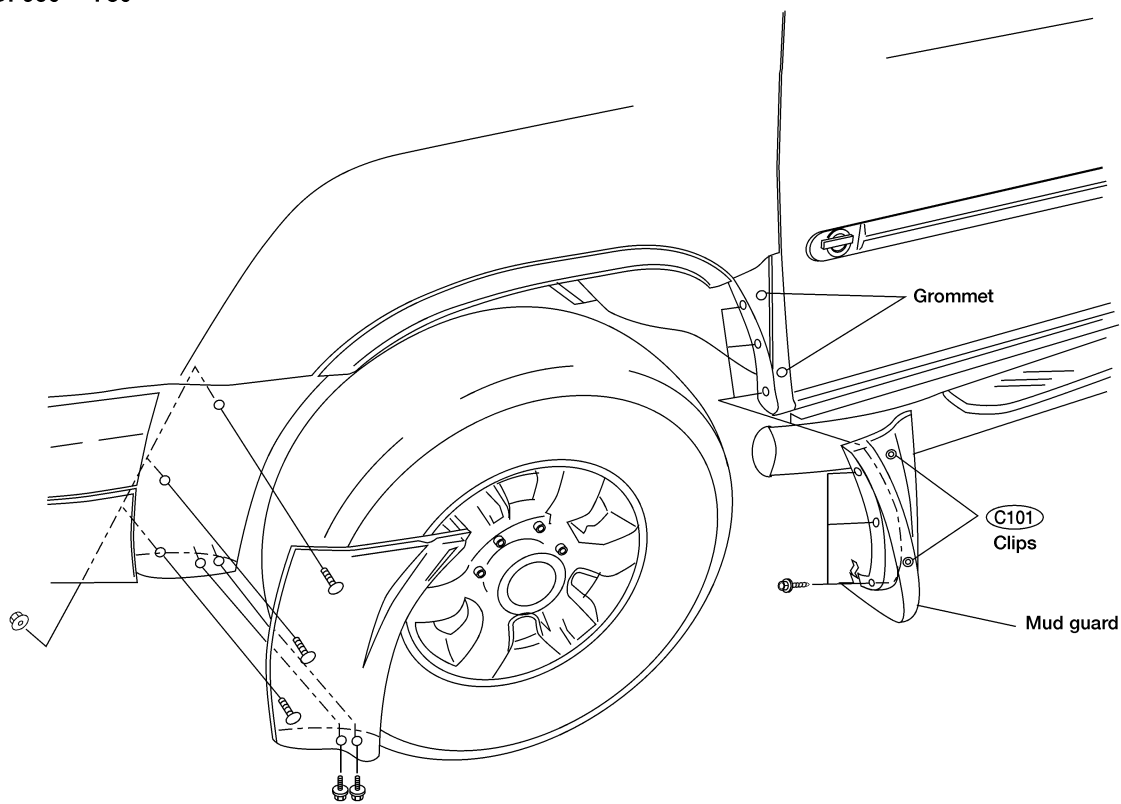

GI

MA

EM

LC

EC

FE

CL

MT

AT

TF

PD

AX

SU

BR

ST

RS

**BT**

HA

SC

EL

IDX

ABT456

# EXTERIOR

Removal and Installation (Cont'd)

SEC. 730

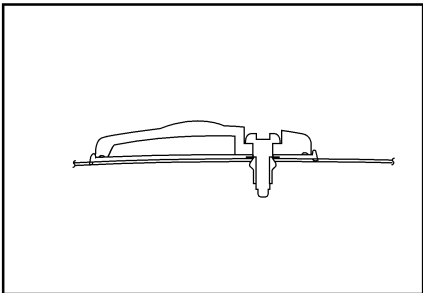
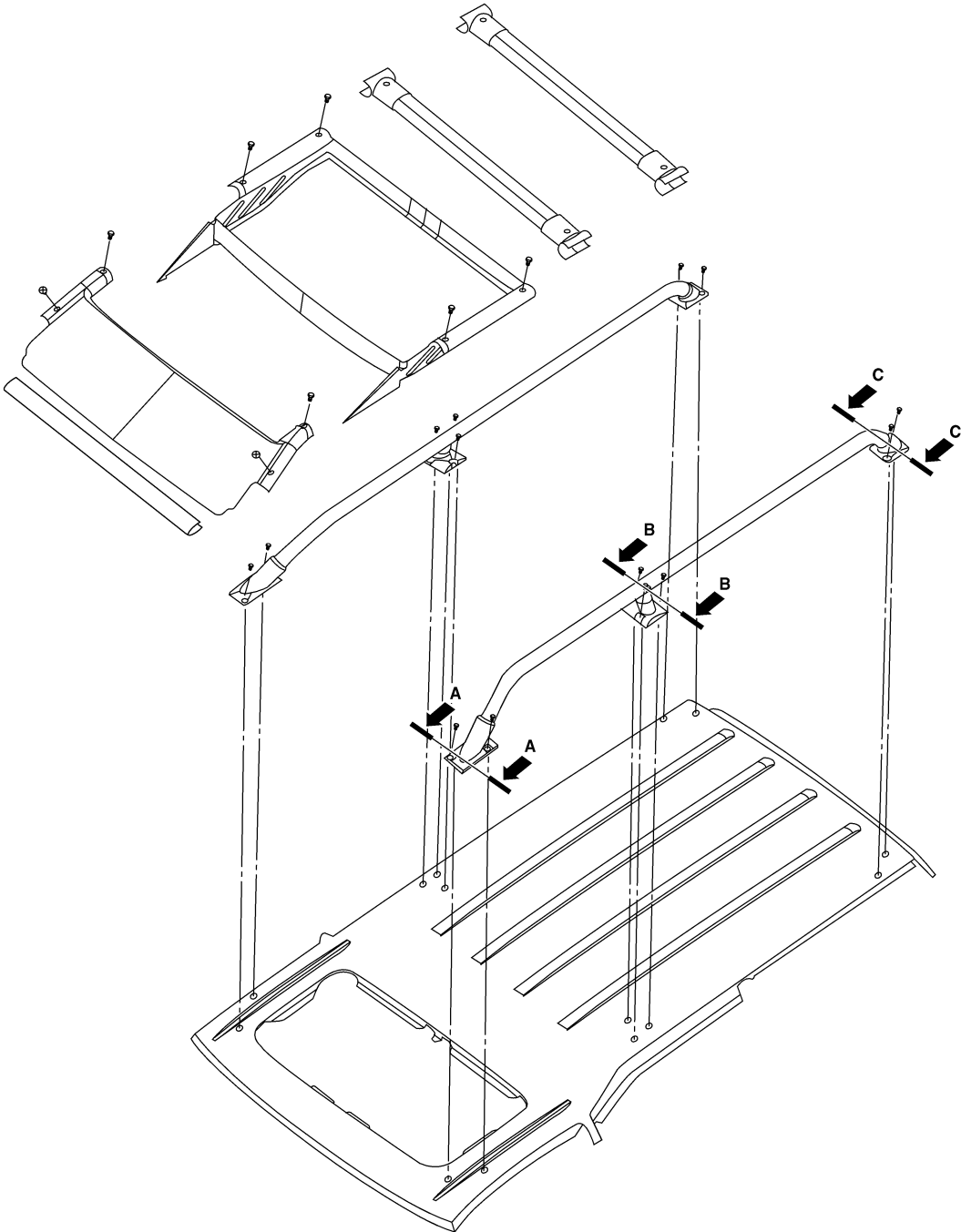

A-A

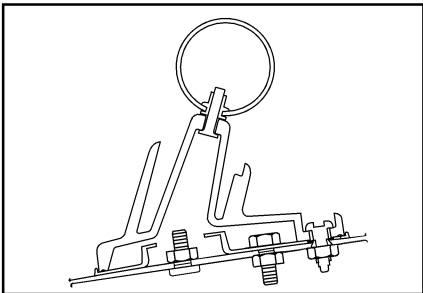

B-B

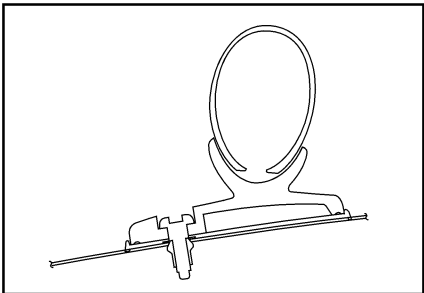

C-C

WBT083

# FRONT SEAT

Removal and Installation

## Removal and Installation

NGBT0014

- When removing and installing the seat trim, carefully handle it to keep dirt out and avoid damage.

SEC. 868•870

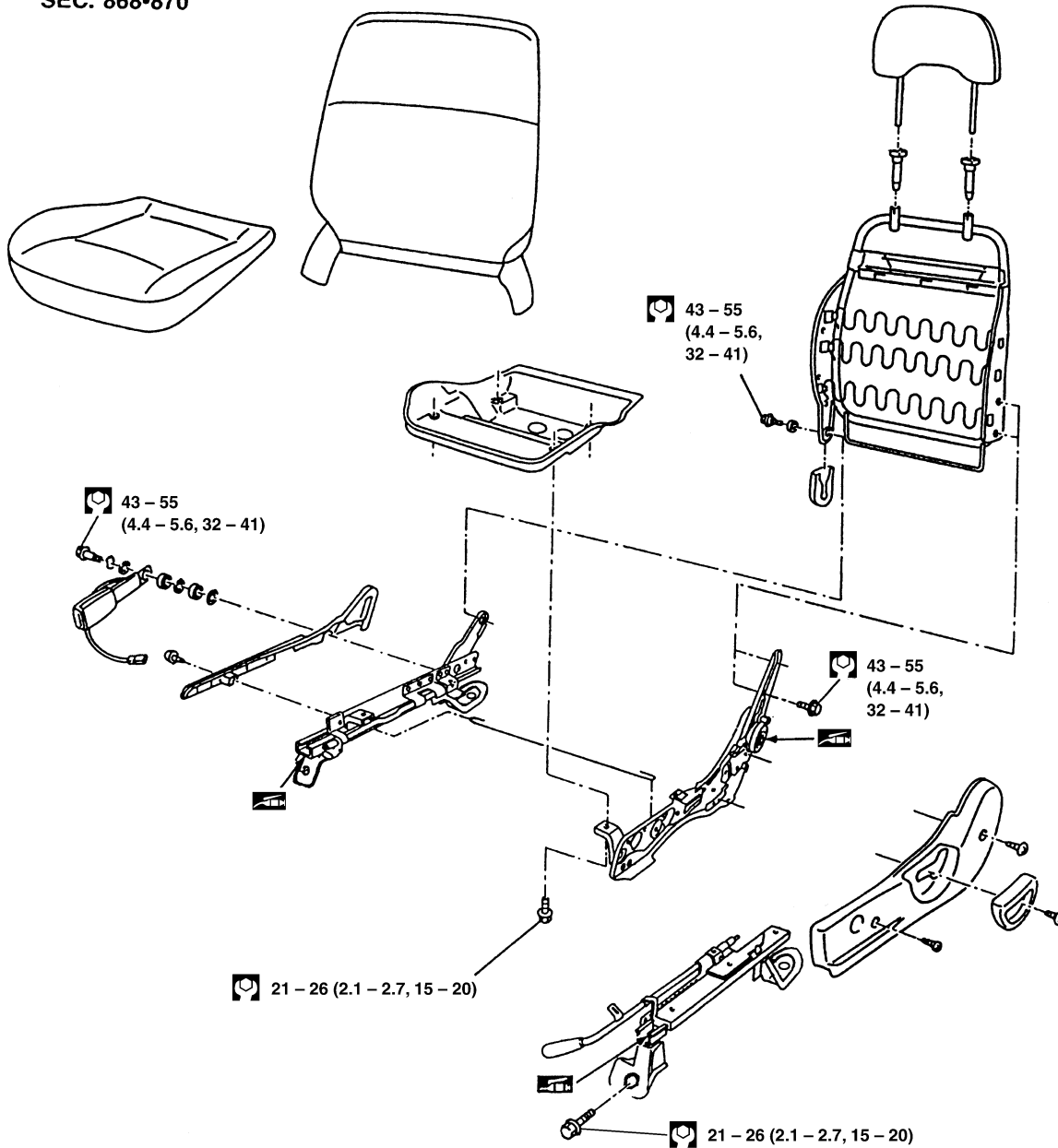

- : N·m (kg·m, ft·lb)
- : Grease-up point  
(Do not apply too much grease as it will drip)

### Walk-in mechanism

- The walk-in system is non-adjustable.

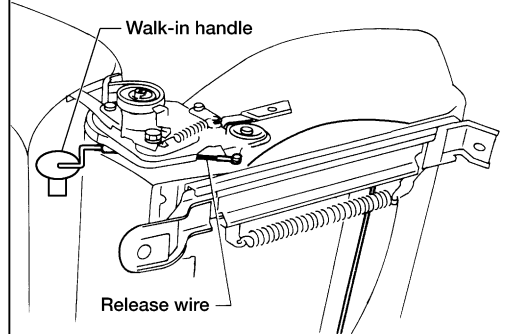

GI  
MA  
EM  
LC  
EC  
FE  
CL  
MT  
AT  
TF  
PD  
AX  
SU  
BR  
ST  
RS  
BT  
HA  
SC  
EL  
IDX

ABT480

# REAR SEAT

Removal and Installation

## Removal and Installation

NGBT0015

SEC. 870

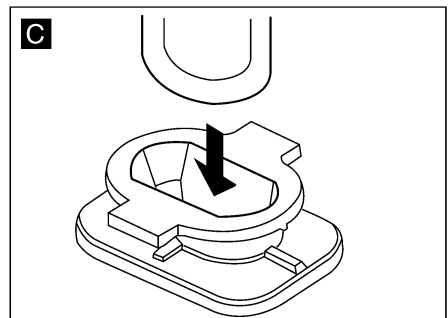
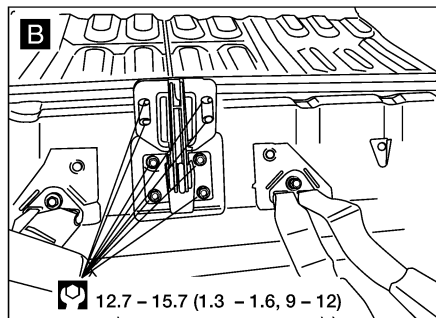
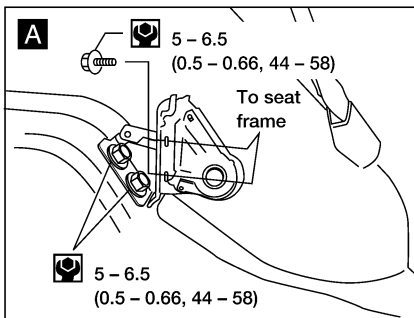
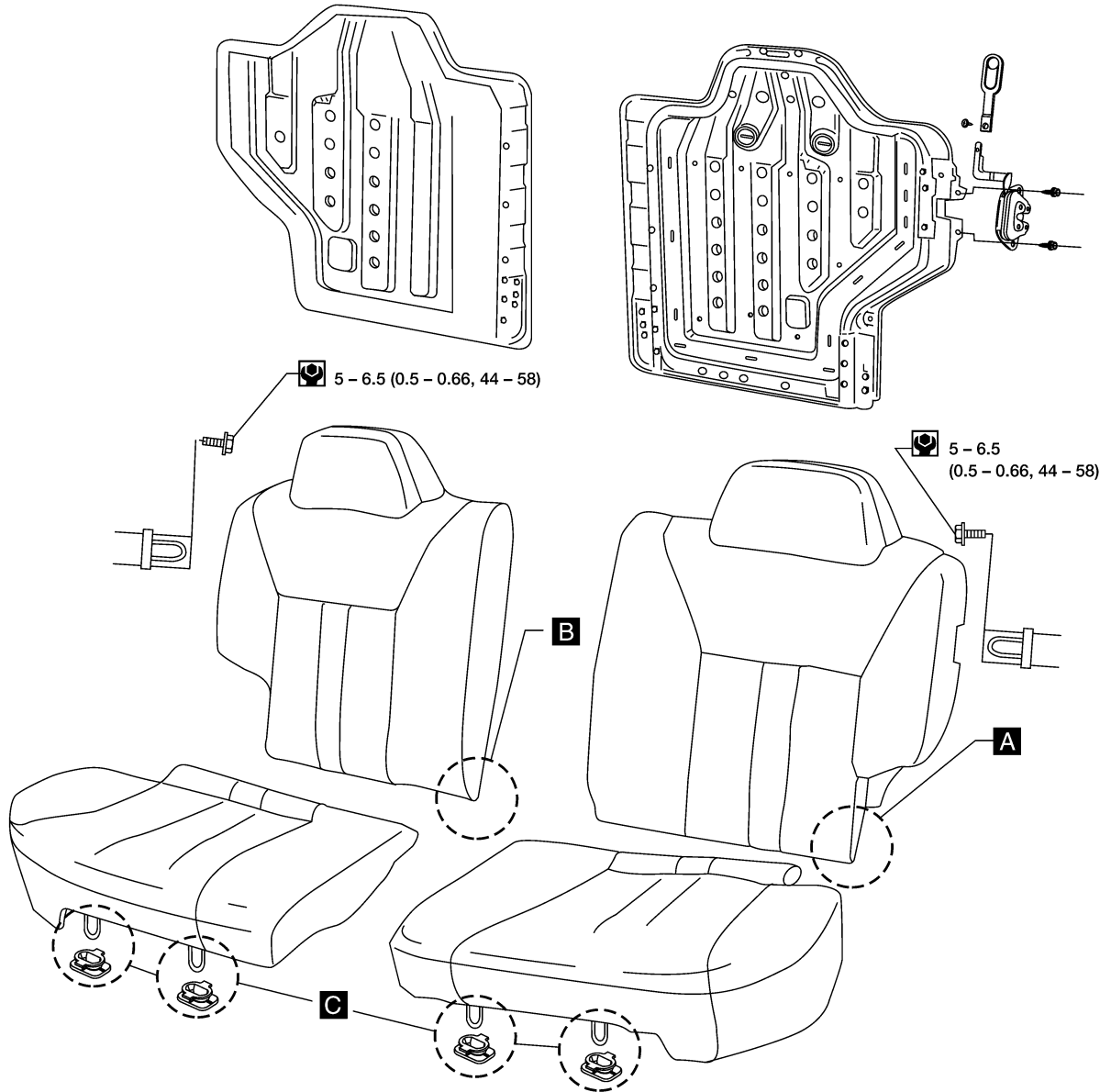

: N•m (kg-m, in-lb)

: N•m (kg-m, ft-lb)

WBT153

# SUNROOF

Removal and Installation

## Removal and Installation

NGBT0016

- Roof rack and gear basket must be removed before sunroof removal.

### SEC. 736

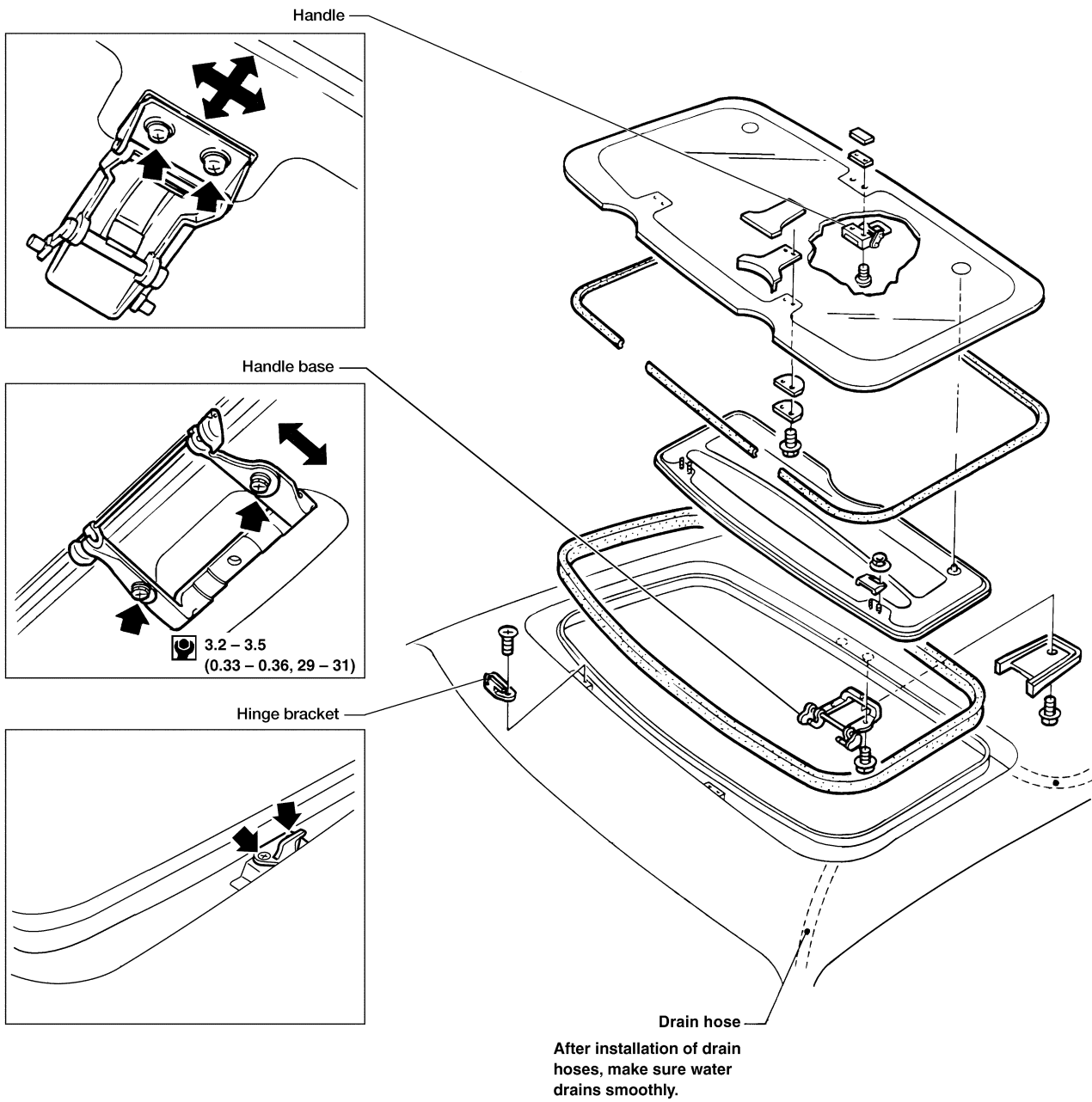

GI

MA

EM

LC

EC

FE

CL

MT

AT

TF

PD

AX

SU

BR

ST

RS

**BT**

HA

SC

EL

IDX

: N·m (kg-m, in-lb)

ABT464

# WINDSHIELD AND WINDOWS

## Removal and Installation

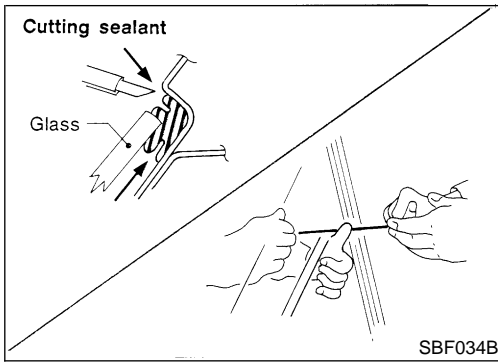

## Removal and Installation

### REMOVAL

After removing moldings, remove glass using piano wire or power cutting tool and an inflatable pump bag.

#### WARNING:

When cutting the glass from the vehicle, always wear safety glasses and heavy gloves to help prevent glass splinters from entering your eyes or cutting your hands.

#### CAUTION:

- Be careful not to scratch the glass when removing.
- Do not set or stand the glass on its edge. Small chips may develop into cracks.

NGBT0017

NGBT0017S01

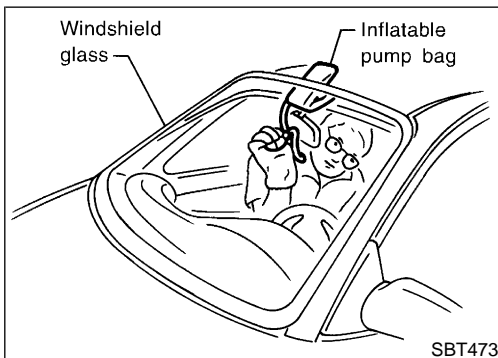
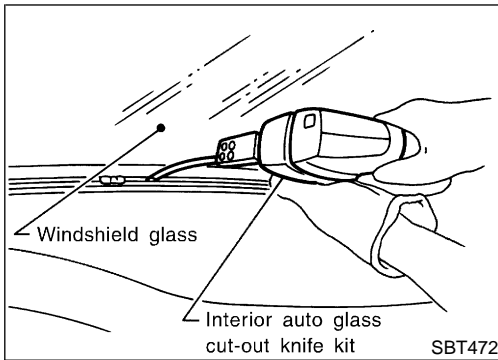

### INSTALLATION

- Use genuine NISSAN Urethane Adhesive Kit or equivalent and follow the instructions furnished with it.
- While the urethane adhesive is curing, open a door window. This will prevent the glass from being forced out by passenger compartment air pressure when a door is closed.
- The molding must be installed securely so that it is in position and leaves no gap.
- Inform the customer that the vehicle should remain stationary until the urethane adhesive has completely cured (preferably 24 hours). Curing time varies with temperature and humidity.

#### WARNING:

- Keep heat and open flames away as primers and adhesive are flammable.
- The materials contained in the kit are harmful if swallowed, and may irritate skin and eyes. Avoid contact with the skin and eyes.
- Use in an open, well ventilated location. Avoid breathing the vapors. They can be harmful if inhaled. If affected by vapor inhalation, immediately move to an area with fresh air.
- Driving the vehicle before the urethane adhesive has completely cured may affect the performance of the windshield in case of an accident.

#### CAUTION:

- Do not use an adhesive which is past its usable term. Shelf life of this product is limited to six months after the date of manufacture. Carefully adhere to the expiration or manufacture date printed on the box.
- Keep primers and adhesive in a cool, dry place. Ideally, they should be stored in a refrigerator.

NGBT0017S02



# WINDSHIELD AND WINDOWS

Removal and Installation (Cont'd)

- Do not leave primers or adhesive cartridge unattended with their caps open or off.
- The vehicle should not be driven for at least 24 hours or until the urethane adhesive has completely cured. Curing time varies depending on temperature and humidities. The curing time will increase under higher temperatures and lower humidities.

## WINDSHIELD

NGBT0017S03

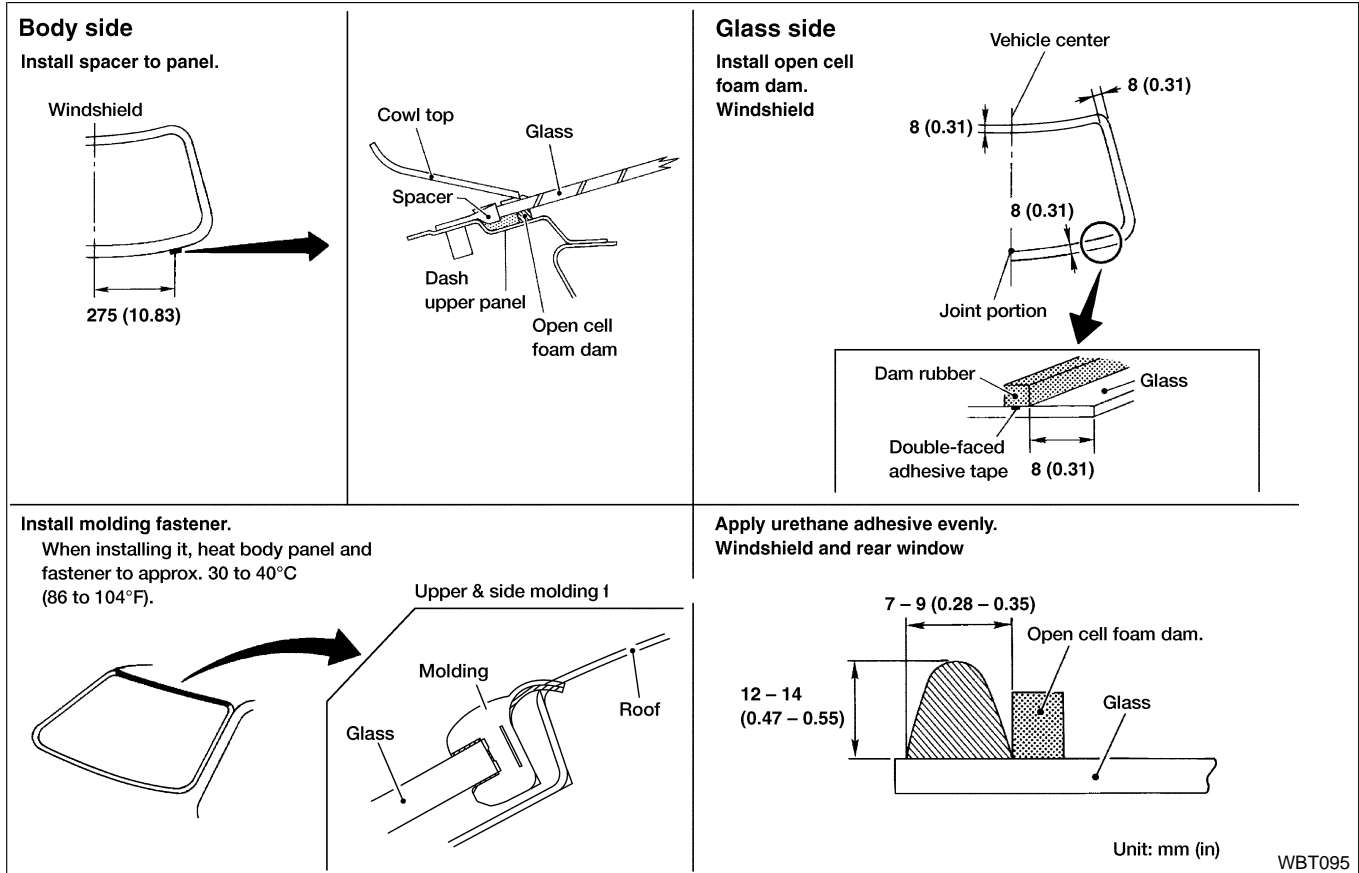

WBT095

GI  
MA  
EM  
LC  
EC  
FE  
CL  
MT  
AT  
TF  
PD  
AX  
SU  
BR  
ST  
RS  
BT  
HA  
SC  
EL  
IDX

# WINDSHIELD AND WINDOWS

Removal and Installation (Cont'd)

## REAR SIDE WINDOW

NGBT0017S04

SEC. 830

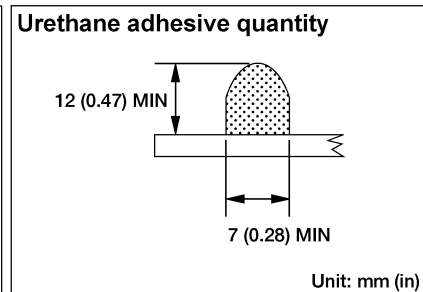
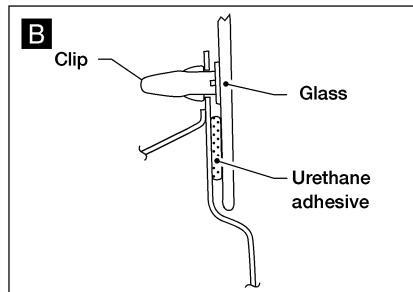
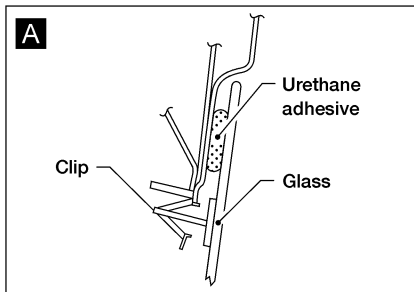
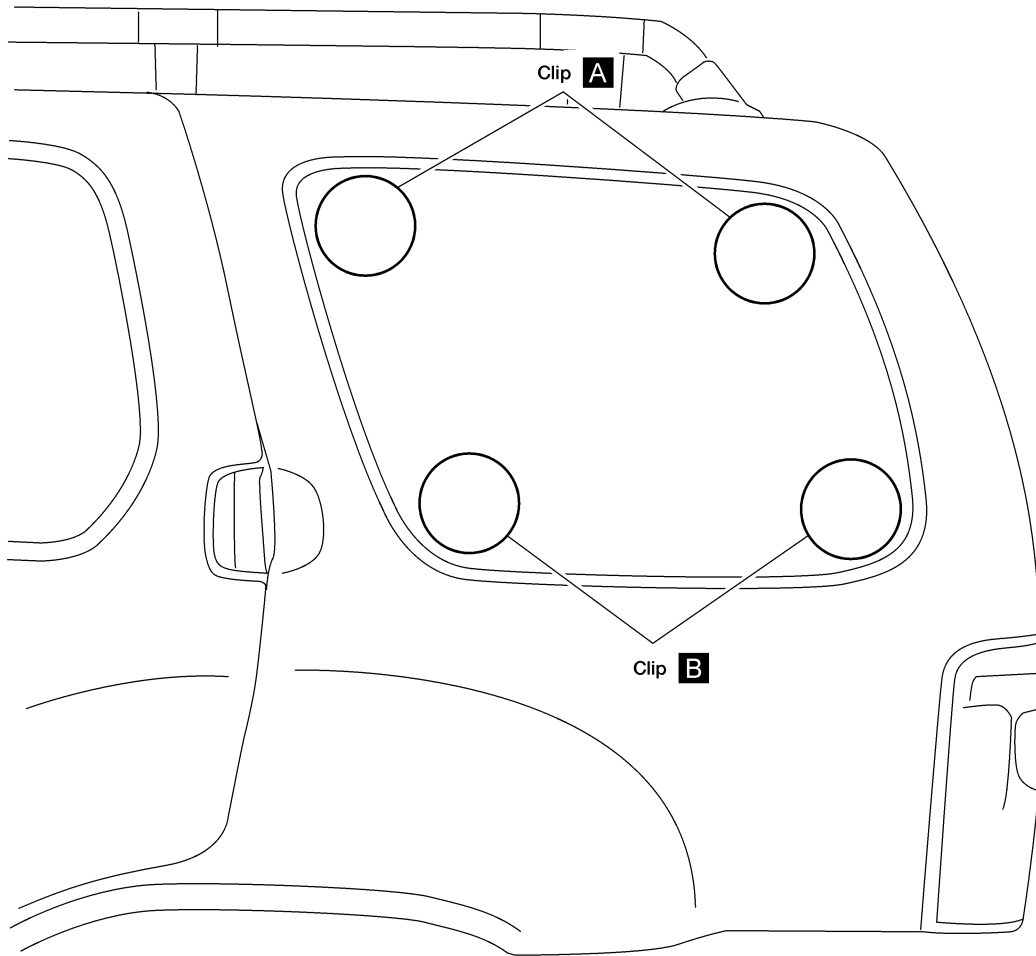

ABT448

# WINDSHIELD AND WINDOWS

Removal and Installation (Cont'd)

## Repairing Water Leaks for Windshield, Side Window

NGBT0017S05

NGBT0017S0501

Leaks can be repaired without removing and reinstalling glass.

**If water is leaking between urethane adhesive material and body or glass, determine the extent of leakage. This can be done by applying water to the windshield or side window area while pushing glass outward.**

To stop the leak, apply primer (if necessary) and then urethane adhesive to the leak point.

GI

MA

EM

LC

EC

FE

CL

MT

AT

TF

PD

AX

SU

BR

ST

RS

**BT**

HA

SC

EL

IDX

# REAR VIEW MIRROR

Removal

## Removal

Remove rear view mirror by deflecting spring with screwdriver as shown in the figure. NGBT0018

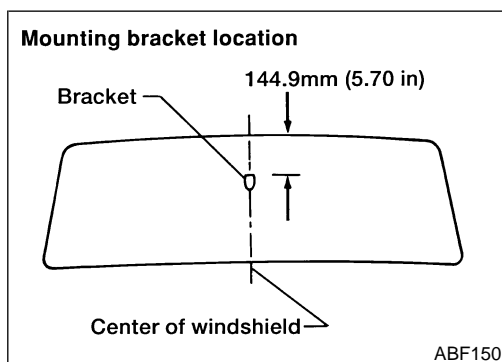
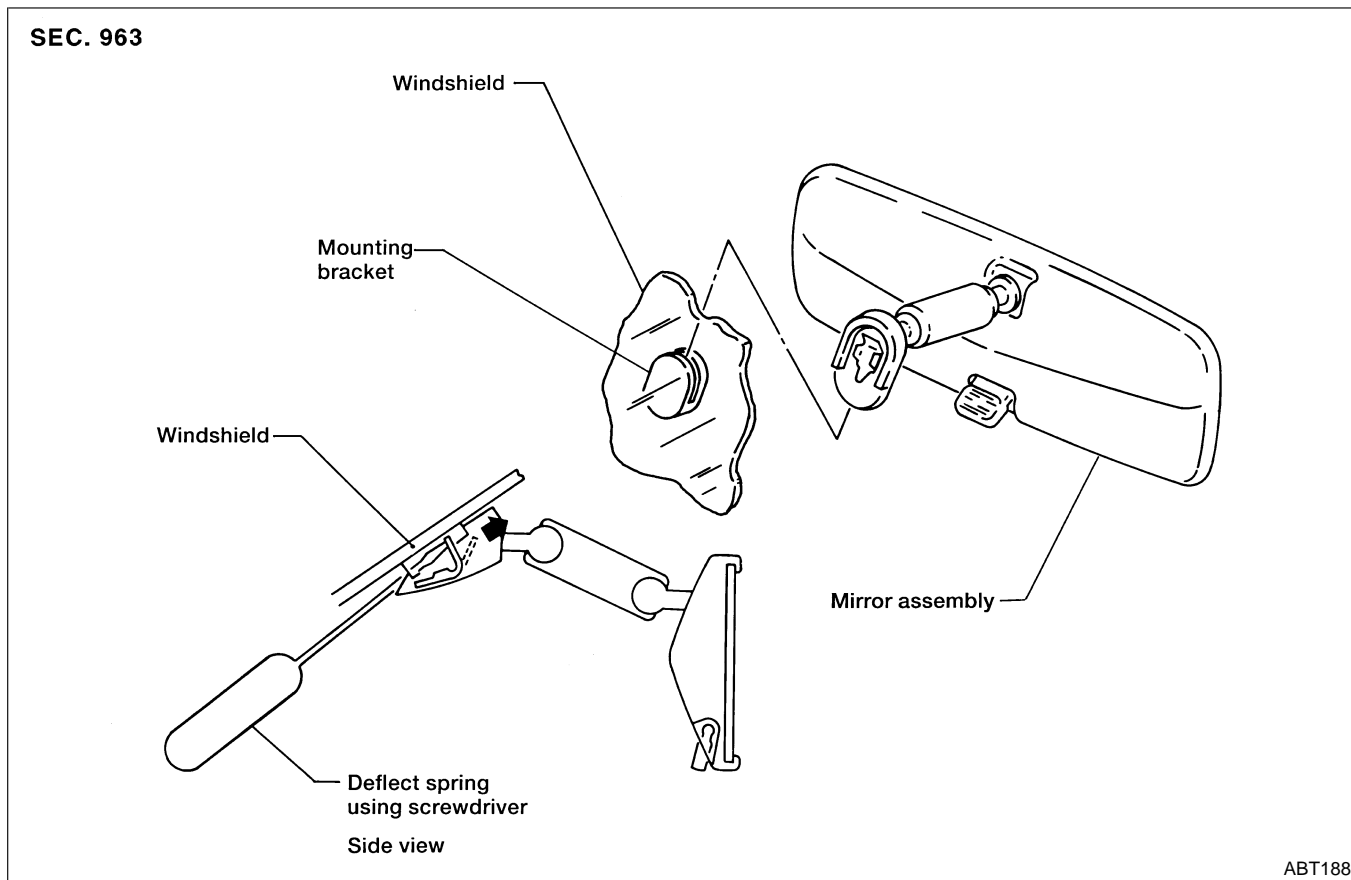

## Installation

NGBT0019

1. Install mounting bracket as follows:
  - a. Determine mounting bracket position on windshield by measuring from top of windshield to top of mounting bracket as shown in the figure.
  - b. Mark location on outside of windshield with wax pencil or equivalent.
  - c. Clean attaching point on inside of windshield with an alcohol-saturated paper towel.
  - d. Sand bonding surface of mounting bracket with sandpaper (No. 320 or No. 360).
  - e. Clean bonding surface of mounting bracket with an alcohol-saturated paper towel.
  - f. Apply Loctite Adhesive 11067-2 or equivalent to bonding surface of mounting bracket.
  - g. Install mounting bracket at pre-marked position and press mounting bracket against glass for 30 to 60 seconds.
  - h. After five minutes, wipe off excess adhesive with an alcohol-moistened paper towel.
2. Install rear view mirror.

# DOOR MIRROR

Removal and Installation

## Removal and Installation

NGBT0020

**CAUTION:**

Be careful not to scratch door rear view mirror body.

★ For Wiring Diagram, refer to *EL-149*, "DOOR MIRROR".

1. Remove door trim or inner cover from front corner of door. Refer to "Removal and Installation", BT-27.
2. Disconnect door mirror harness connector.
3. Remove bolts securing door mirror, then remove door mirror assembly.

SEC. 963

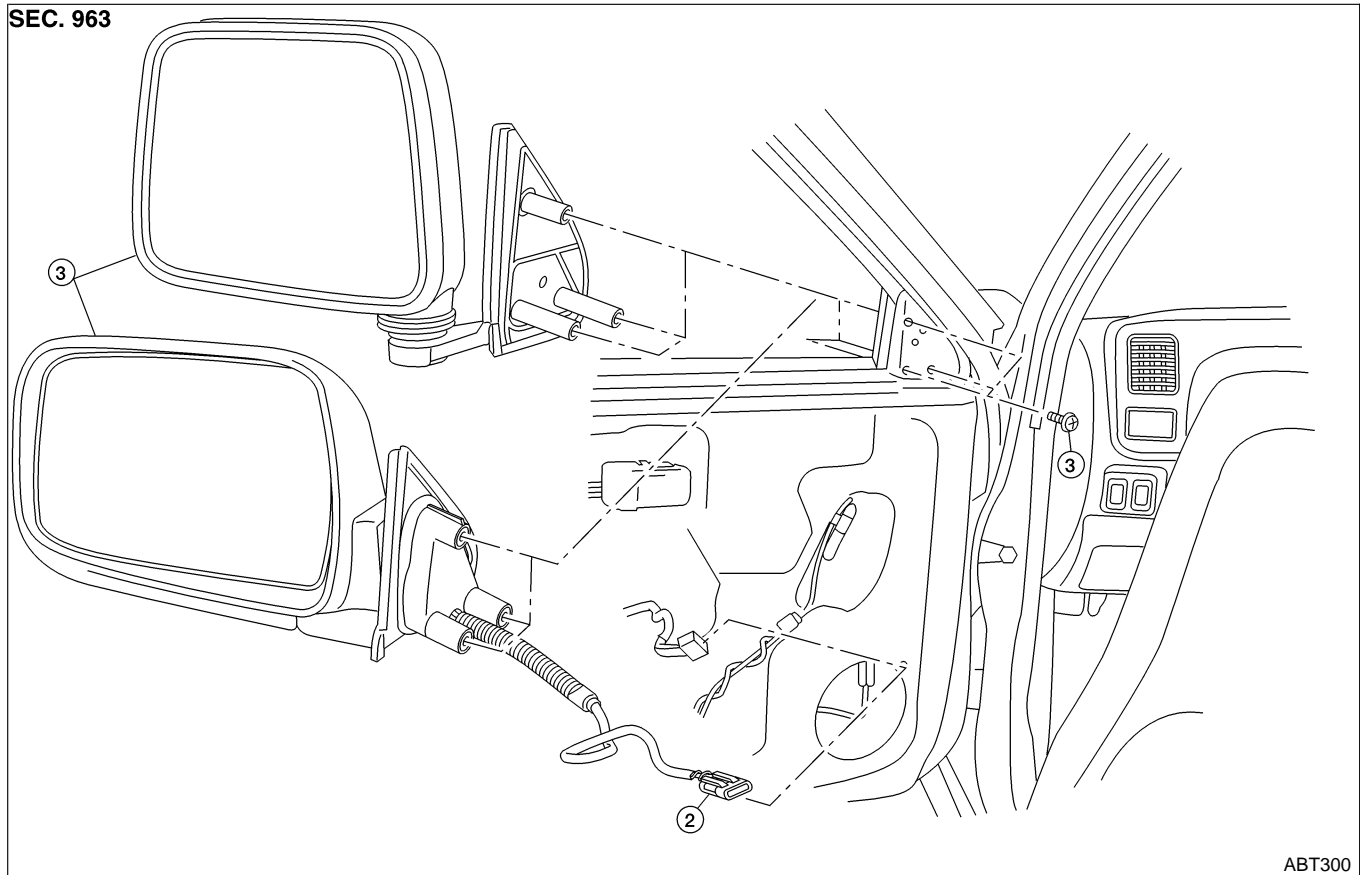

GI

MA

EM

LC

EC

FE

CL

MT

AT

TF

PD

AX

SU

BR

ST

RS

**BT**

HA

SC

EL

IDX

# CAB AND REAR BODY

Body Mounting

## Body Mounting

NGBT0021

When removing, be sure to replace bolts and nuts (sealant applied bolts or self-lock nuts are used for all mounting).

SEC. 930

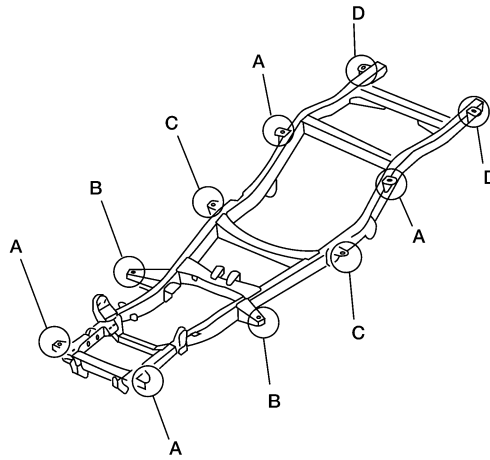

A

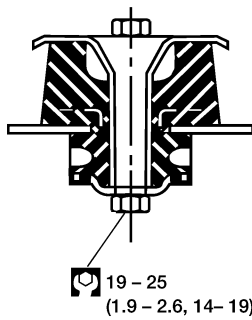

B

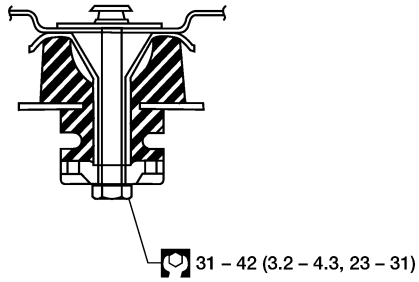

C

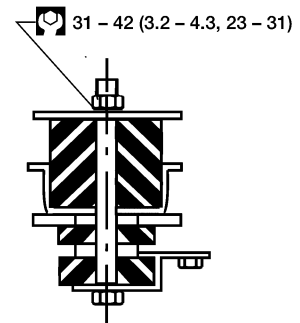

D

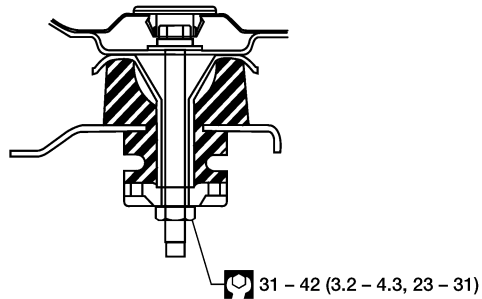

 : N-m (kg-m, ft-lb)

WBT151

# BODY (ALIGNMENT)

Alignment

## Alignment

NGBT0022

- All dimensions indicated in the figures are actual.
- When using a tracking gauge, adjust both pointers to equal length, then check pointers and the gauge to make sure there is no free play.
- When a measuring tape is used, check to be sure there is no elongation, twisting or bending.
- Measurements should be taken at the center of the mounting holes.
- An asterisk (\*) following the value at the measuring point indicates that the measuring point on the other side is symmetrically the same value.
- The coordinates of the measurement points are the distances measured from the standard line of "X", "Y" and "Z".

(LH) : LH side  
(RH) : RH side

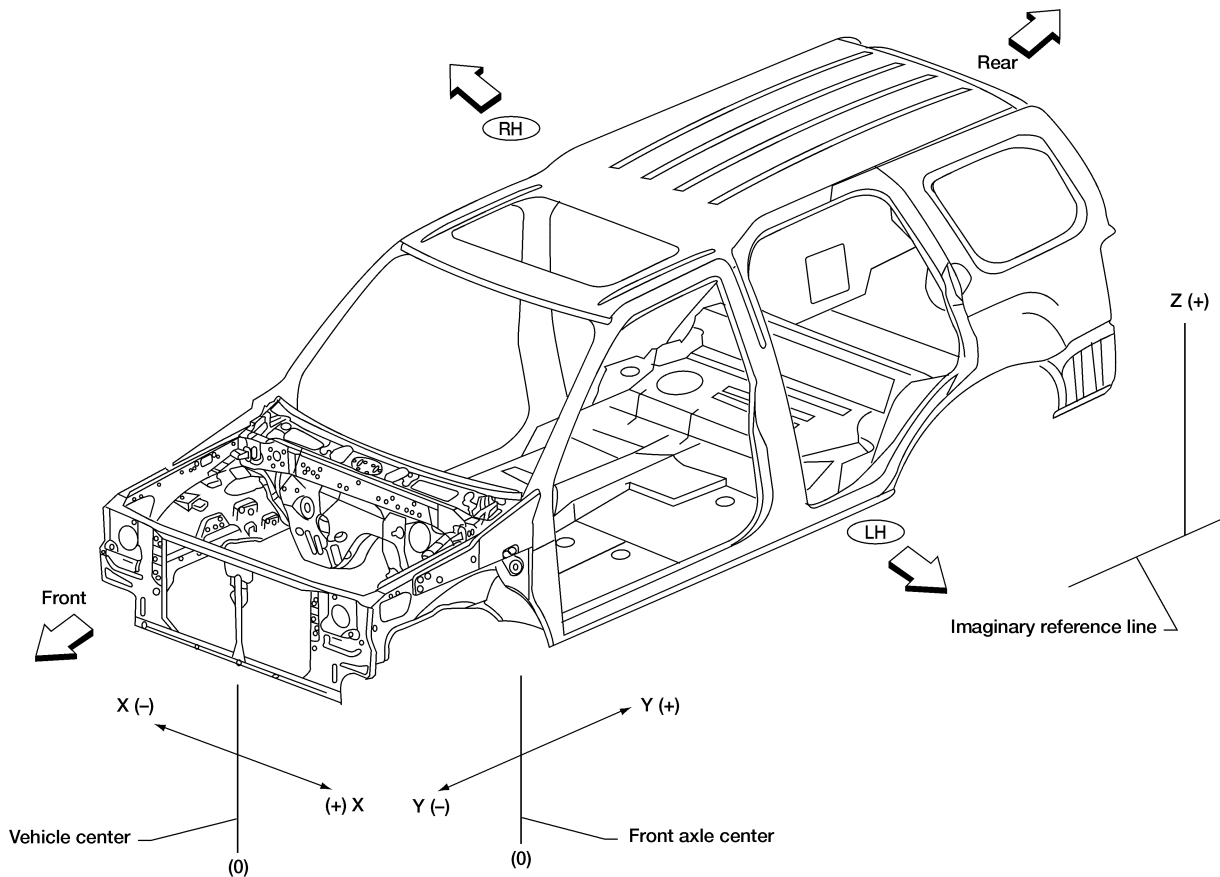

"X" : Vehicle center  
"Y" : Center line of front axle  
"Z" : Imaginary reference line  
[300mm below datum line  
("OZ" at design plan)]

ABM356

# BODY (ALIGNMENT)

Alignment (Cont'd)

## ENGINE COMPARTMENT Measurement

NGBT0022S01

NGBT0022S0103

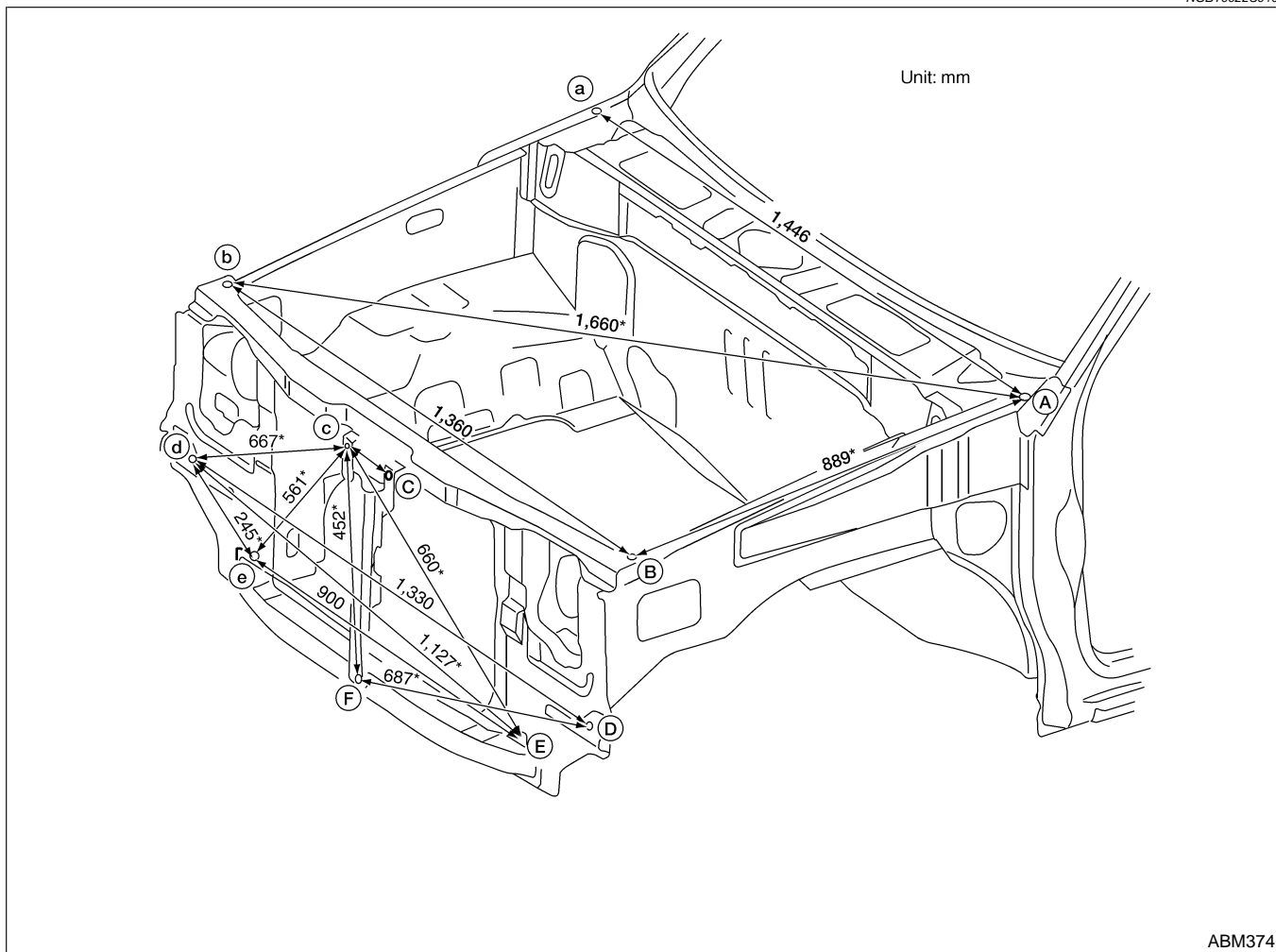

Figure marked with \* indicate symmetrically identical dimensions on both right- and left-hand sides of the vehicle.



# BODY (ALIGNMENT)

Alignment (Cont'd)

## Measurement Points

NGBT0022S0104

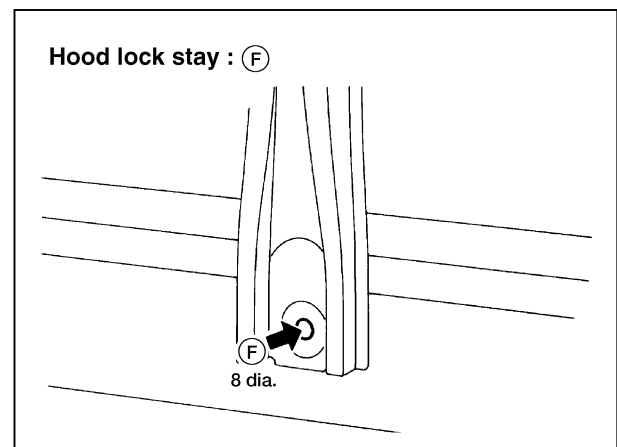
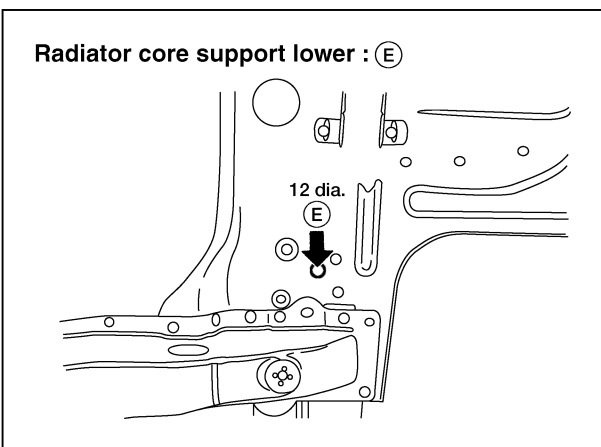
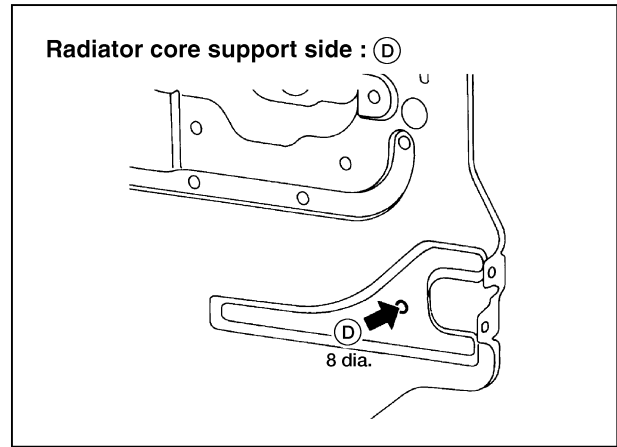
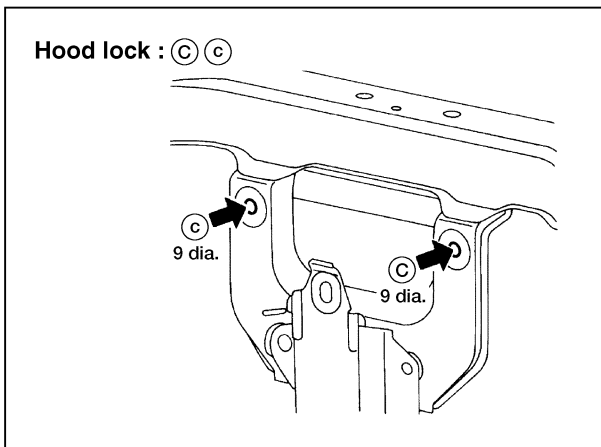
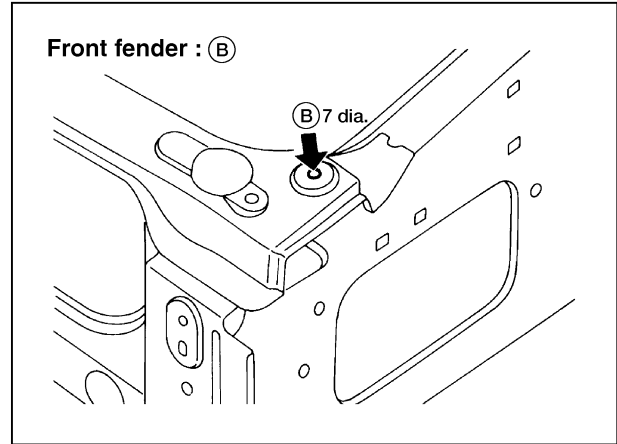
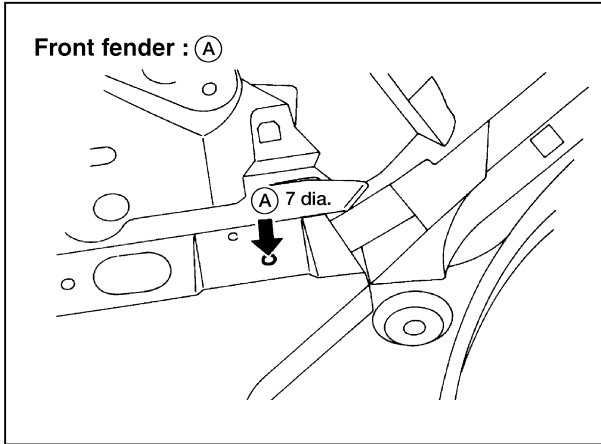

Unit: mm

GI  
MA  
EM  
LC  
EC  
FE  
CL  
MT  
AT  
TF  
PD  
AX  
SU  
BR  
ST  
RS  
BT  
HA  
SC  
EL  
IDX

# BODY (ALIGNMENT)

Alignment (Cont'd)

## UNDERBODY Measurement

NGBT0022S02

NGBT0022S0205

Unit:mm

Figures marked with a \* indicate symmetrically identical dimensions on both right and left hand sides of the vehicle.

As viewed from underside.

All dimensions indicated in the figure are actual.

LH side

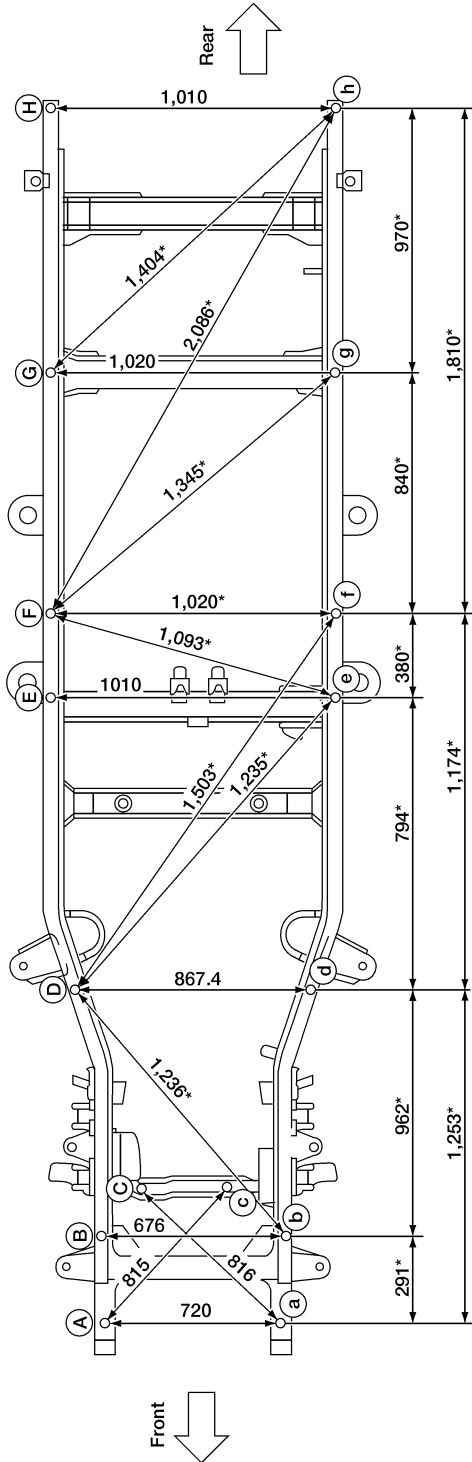

RH side

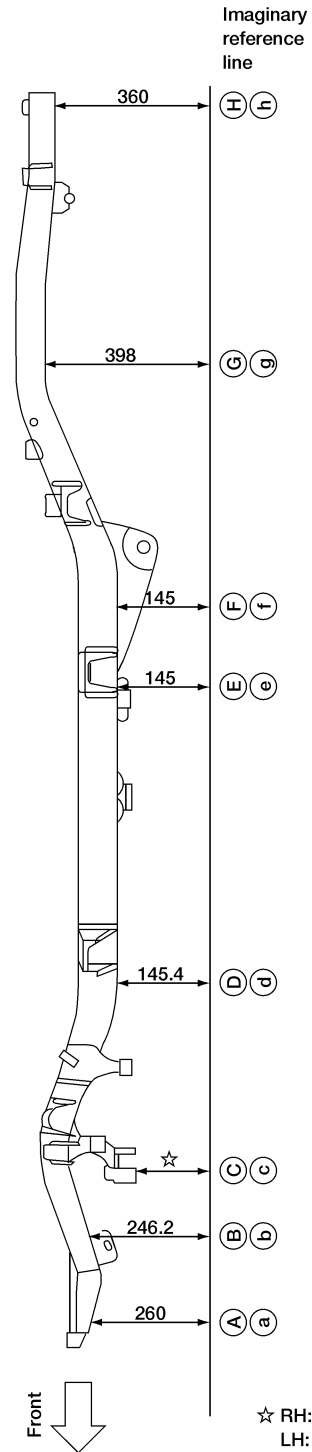

☆ RH: 105  
LH: 97

# BODY (ALIGNMENT)

Alignment (Cont'd)

## Measurement Points

NGBT0022S0206

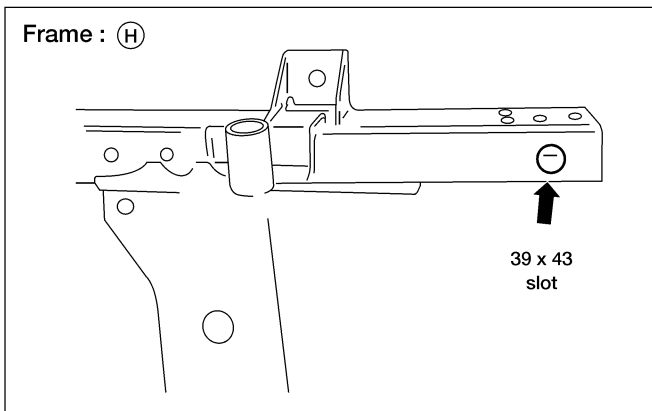
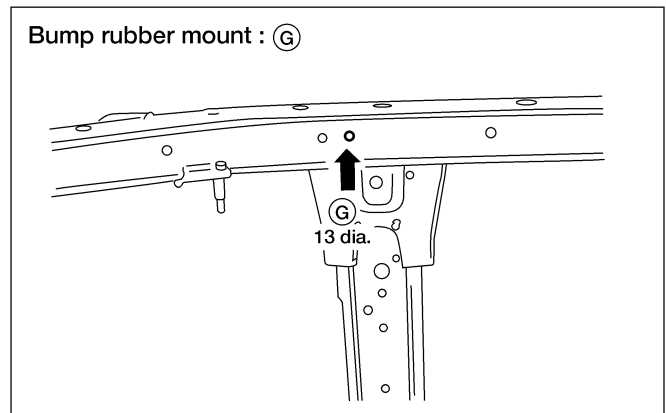
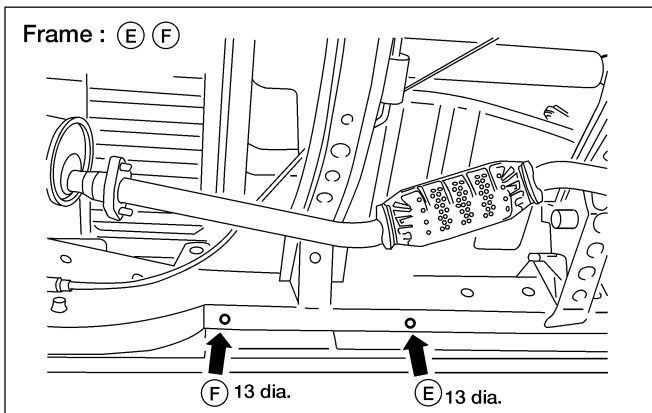
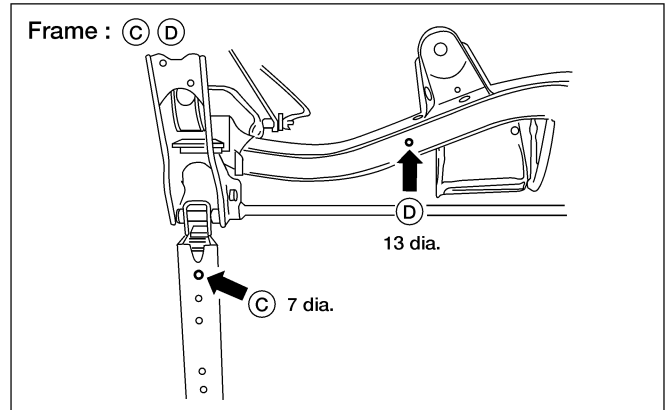
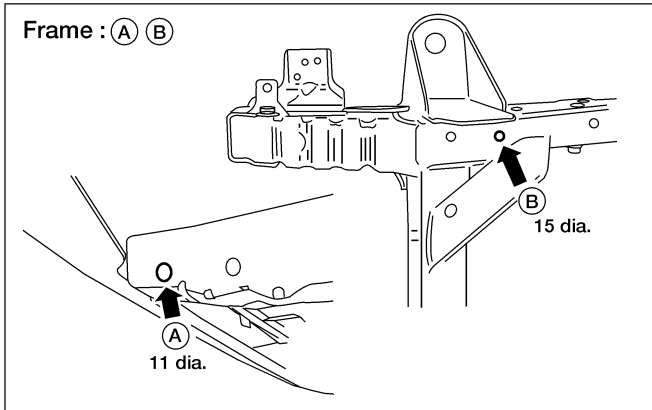

### Coordinates:

(A), (a)	(E), (e)
X: 360	X: 515
Y: -700	Y: 1340
Z: 260	Z: 145
(B), (b)	(F), (f)
X: 338	X: 510
Y: -409	Y: 1720
Z: 246.2	Z: 145
(C), (c)	(G), (g)
X: 200	X: 510
Y: -129	Y: 2560
Z: RH 105 LH 97	Z: 398
(D), (d)	(H), (h)
X: 434	X: 505
Y: 550	Y: 3530
Z: 145.4	Z: 360

GI

MA

EM

LC

EC

FE

CL

MT

AT

TF

PD

AX

SU

BR

ST

RS

**BT**

HA

SC

EL

IDX

ABM437

## NOTES