

# SECTION TF

GI  
MA  
EM  
LC  
EC  
FE  
CL  
MT  
AT  
TF  
PD  
AX  
SU  
BR  
ST  
RS  
BT  
HA  
SC  
EL  
IDX

## CONTENTS

<b>PREPARATION</b> .....	2	<b>ASSEMBLY</b> .....	23
Special Service Tools .....	2	Main Gear .....	23
Commercial Service Tools .....	3	DISASSEMBLY .....	23
<b>NOISE, VIBRATION AND HARSHNESS (NVH)</b>		INSPECTION .....	24
<b>TROUBLESHOOTING</b> .....	5	ASSEMBLY .....	24
NVH Troubleshooting Chart .....	5	Front Case .....	25
TRANSFER .....	5	REMOVAL .....	25
<b>DESCRIPTION</b> .....	6	INSTALLATION .....	25
Cross-sectional View .....	6	Front Case Cover .....	25
<b>ON-VEHICLE SERVICE</b> .....	7	REMOVAL .....	25
Replacing Oil Seal .....	7	INSTALLATION .....	25
CENTER CASE OIL SEAL .....	7	Bearing Retainer .....	26
SHIFT SHAFT OIL SEAL .....	8	REMOVAL .....	26
REAR OIL SEAL .....	8	INSTALLATION .....	26
Position Switch Check .....	9	Center Case .....	26
<b>REMOVAL AND INSTALLATION</b> .....	10	REMOVAL .....	26
Removal .....	10	INSTALLATION .....	26
Installation .....	10	Rear Case .....	26
M/T MODEL .....	10	REMOVAL .....	26
A/T MODEL .....	10	INSTALLATION .....	27
<b>OVERHAUL</b> .....	11	Shift Control Components .....	27
Transfer Gear Control .....	11	INSPECTION .....	27
Case Components .....	12	<b>ASSEMBLY</b> .....	29
Gear Components .....	13	<b>SERVICE DATA AND SPECIFICATIONS (SDS)</b> .....	37
Shift Control Components .....	14	General Specifications .....	37
<b>DISASSEMBLY</b> .....	15	Inspection and Adjustment .....	37
<b>REPAIR FOR COMPONENT PARTS</b> .....	20	CLEARANCE BETWEEN FRONT DRIVE	
Mainshaft .....	20	SPROCKET AND 2-4 COUPLING SLEEVE .....	37
DISASSEMBLY .....	20	GEAR END PLAY .....	37
INSPECTION .....	21	CLEARANCE BETWEEN BAULK RING AND	
ASSEMBLY .....	22	CLUTCH GEAR .....	37
Front Drive Shaft .....	22	Available Shim .....	37
DISASSEMBLY .....	22	COUNTER GEAR REAR BEARING .....	37
INSPECTION .....	22	Available Snap Ring .....	37
ASSEMBLY .....	22	MAINSHAFT FRONT BEARING .....	37
Counter Gear .....	23	MAIN GEAR BEARING .....	38
DISASSEMBLY .....	23	MAINSHAFT REAR BEARING .....	38
INSPECTION .....	23		

# PREPARATION

Special Service Tools

## Special Service Tools

NGTF0001

The actual shapes of Kent-Moore tools may differ from those of special service tools illustrated here.

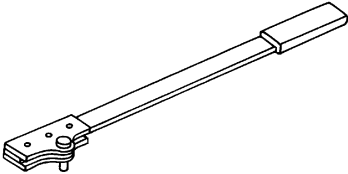
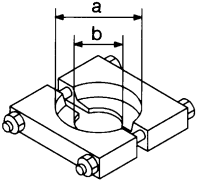
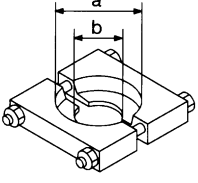
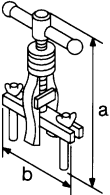
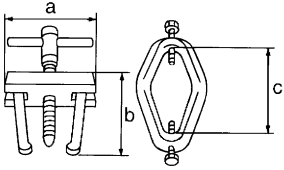
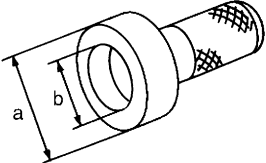
Tool number (Kent-Moore No.) Tool name	Description	
KV38108300 ( — ) Companion Flange wrench		Removing companion flange nut Installing companion flange nut  NT771
ST30021000 (J22912-01) Puller		Removing counter gear front bearing (Use with ST36710010) Removing L & H hub <b>a: 110 mm (4.33 in) dia.</b> <b>b: 68 mm (2.68 in) dia.</b>  NT411
ST30031000 (J22912-01) Puller		Removing counter gear rear bearing (Use with ST36710010) <b>a: 90 mm (3.54 in) dia.</b> <b>b: 50 mm (1.97 in) dia.</b>  NT411
ST33290001 (J34286) Puller		Removing center case oil seal Removing rear oil seal <b>a: 250 mm (9.84 in)</b> <b>b: 160 mm (6.30 in)</b>  NT414
ST33051001 (J22888) Puller		Removing companion flange <b>a: 135 mm (5.31 in)</b> <b>b: 100 mm (3.94 in)</b> <b>c: 130 mm (5.12 in)</b>  NT657
ST30720000 1 (J25273) 2 (J25405) Drift		1 Installing center case oil seal 2 Installing rear oil seal <b>a: 77 mm (3.03 in) dia.</b> <b>b: 55.5 mm (2.185 in) dia.</b>  NT658

# PREPARATION

Special Service Tools (Cont'd)

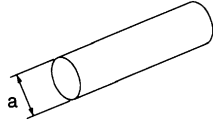
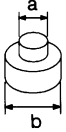
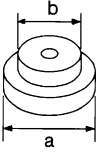
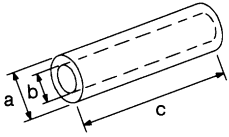
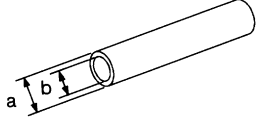
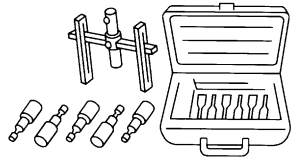
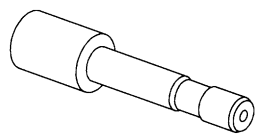
Tool number (Kent-Moore No.) Tool name	Description	
ST36710010 ( — ) Drift	 <p>Removing counter gear front bearing (Use with ST30021000) Removing counter gear rear bearing (Use with ST30031000) <b>a: 34.5 mm (1.358 in) dia.</b></p>	GI MA EM
NT063		
ST33061000 (J8107-2) Drift	 <p>Removing main gear bearing <b>a: 28.5 mm (1.122 in) dia.</b> <b>b: 38 mm (1.50 in) dia.</b></p>	LC EC
NT116		
ST30613000 1 (J25742-3) 2 (J34339) Drift	 <p>1 Installing main gear bearing 2 Installing front case cover oil seal <b>a: 72 mm (2.83 in) dia.</b> <b>b: 48 mm (1.89 in) dia.</b></p>	FE CL
NT073		
(J35864) Drift	 <p>Installing shift shaft oil seal <b>a: 26 mm (1.02 in) dia.</b> <b>b: 20 mm (0.79 in) dia.</b> <b>c: 150 mm (5.91 in)</b></p>	MT AT
NT117		
(J26092) Drift	 <p>Seating counter gear assembly <b>a: 44.5 mm (1.752 in) dia.</b> <b>b: 38.5 mm (1.516 in) dia.</b></p>	TF PD
NT065		
(J34291) Shim setting gauge set	 <p>Selecting counter gear rear bearing shim</p>	AX SU BR
NT101		
(J34291-20) Plunger-shim setting gauge	 <p>Selecting counter gear rear bearing shim</p>	ST RS
NT118		

## Commercial Service Tools

NGTF0002

The actual shapes of Kent-Moore tools may differ from those of special service tools illustrated here.

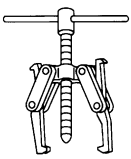
Tool name	Description	
Puller	 <p>Removing front drive shaft front bearing Removing front drive shaft rear bearing Removing main gear bearing</p>	HA SC EL
NT077		

# PREPARATION

Commercial Service Tools (Cont'd)

Tool name	Description
Drift	<div data-bbox="560 254 784 384" data-label="Image">A technical drawing of a cylindrical drift tool. It shows a perspective view of a cylinder with a smaller diameter section at one end. Dimension 'a' is the length of the smaller diameter section. Dimension 'b' is the diameter of the smaller section. Dimension 'c' is the total length of the cylinder.</div> <p data-bbox="409 405 467 426">NT117</p> <ul data-bbox="950 220 1295 447" style="list-style-type: none"><li>1 Installing mainshaft rear bearing</li><li>2 Installing L &amp; H hub</li><li>1 a: 50 mm (1.97 in) dia.</li><li>   b: 42 mm (1.65 in) dia.</li><li>   c: 180 mm (7.09 in)</li><li>2 a: 60 mm (2.36 in) dia.</li><li>   b: 50 mm (1.97 in) dia.</li><li>   c: 60 mm (2.36 in)</li></ul>

# NOISE, VIBRATION AND HARSHNESS (NVH) TROUBLESHOOTING

NVH Troubleshooting Chart

## NVH Troubleshooting Chart

NGTF0039S01

Use the chart below to help you find the cause of the symptom. The numbers indicate the order of inspection. If necessary, repair or replace these parts.

### TRANSFER

NGTF0039S0101

Symptom		SUSPECTED PARTS (Possible cause)										Reference page											
		FLUID (Level low)	FLUID (Wrong)	FLUID (Level too high)	LIQUID GASKET (Damaged)	OIL SEAL (Worn or damaged)	CHECK SPRING AND CHECK BALL (Worn damaged)	SHIFT FORK (Worn)	GEAR (Worn or damaged)	Bearing (Worn or damaged)	BAULK RING (Worn or damaged)		SHIFTING INSERT (Damaged)										
Symptom	Noise	1	2						3	3			MA-40, "Checking Transfer Fluid".	TF-12	TF-12	TF-12, 14	TF-14	TF-13	TF-13	TF-13	TF-13		
	Fluid leakage		3	1	2	2																	
	Hard to shift or will not shift		1	1																			
	Jumps out of gear							1	2	2													

GI

MA

EM

LC

EC

FE

CL

MT

AT

**TF**

PD

AX

SU

BR

ST

RS

BT

HA

SC

EL

IDX

# DESCRIPTION

Cross-sectional View

## Cross-sectional View

NGTF0003

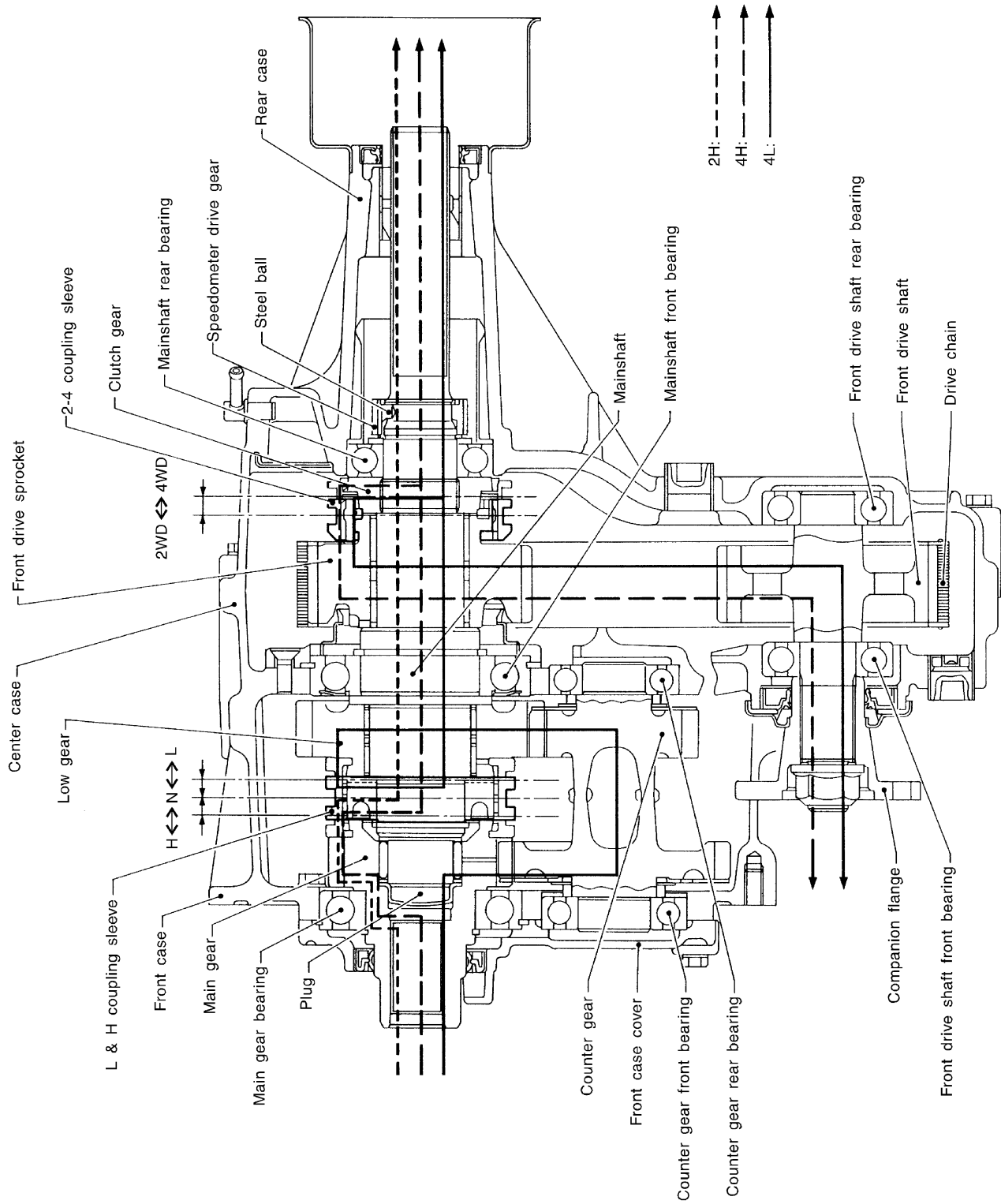

ATF021

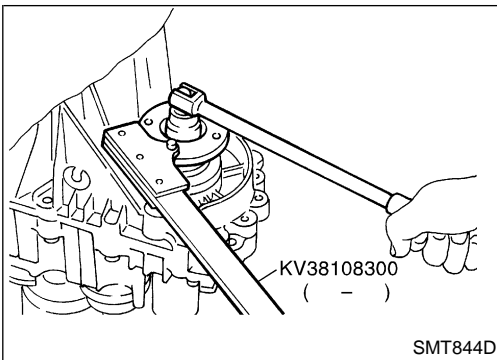

## Replacing Oil Seal CENTER CASE OIL SEAL

NGTF0004

NGTF0004S01

1. Remove front propeller shaft. Refer to **PD-8**, "Removal and Installation".

2. Remove companion flange nut.

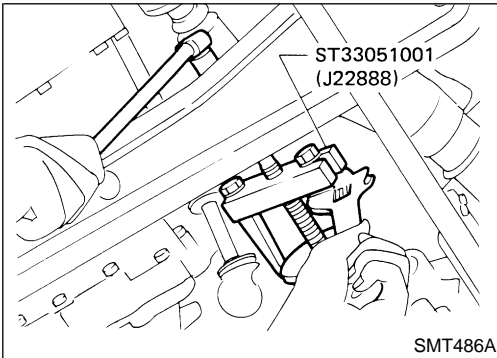

3. Remove companion flange.

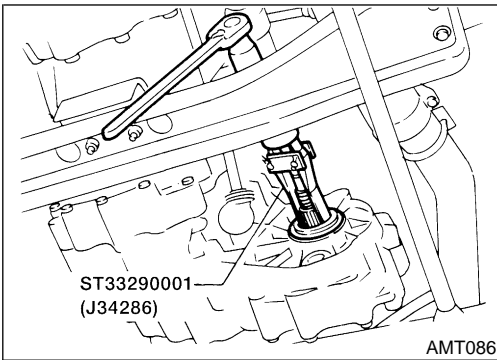

4. Remove center case oil seal.

5. Install center case oil seal.

● **Before installing, apply multi-purpose grease to seal lip.**

6. Install companion flange.

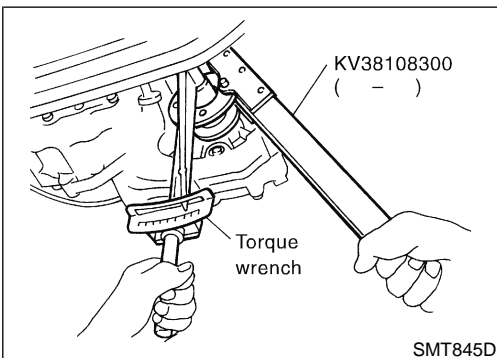

7. Tighten companion flange nut.

 : 226 - 324 N·m (23 - 33 kg·m, 166 - 239 ft·lb)

8. Install front propeller shaft. Refer to **PD-8**, "Removal and Installation".

GI

MA

EM

LC

EC

FE

CL

MT

AT

TF

PD

AX

SU

BR

ST

RS

BT

HA

SC

EL

IDX

# ON-VEHICLE SERVICE

## Replacing Oil Seal (Cont'd)

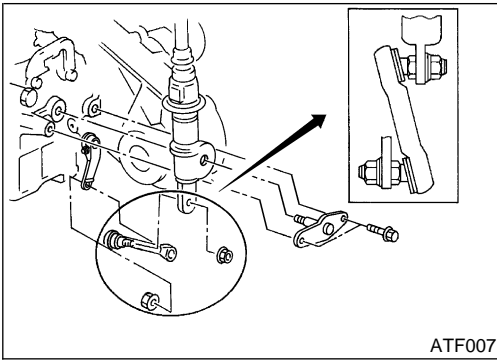

### SHIFT SHAFT OIL SEAL

NGTF0004S02

1. Remove front propeller shaft. Refer to **PD-8**, "Removal and Installation".
2. Remove companion flange. Refer to "CENTER CASE OIL SEAL", TF-7.
3. Remove transfer control lever from transfer outer shift lever. Then remove outer shift lever.
4. Remove shift shaft oil seal.
  - **Be careful not to damage cross shaft.**

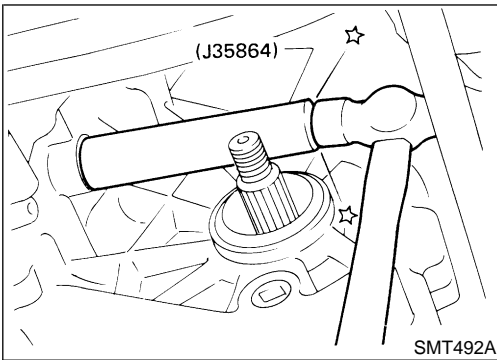
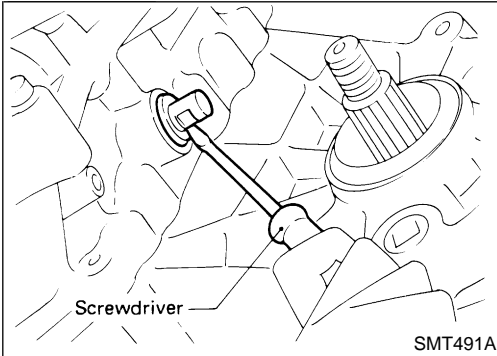

5. Install shift shaft oil seal.
  - **Before installing, apply multi-purpose grease to seal lip.**
6. Install transfer control linkage.
7. Install companion flange. Refer to "CENTER CASE OIL SEAL", TF-7.
8. Install front propeller shaft. Refer to **PD-8**, "Removal and Installation".

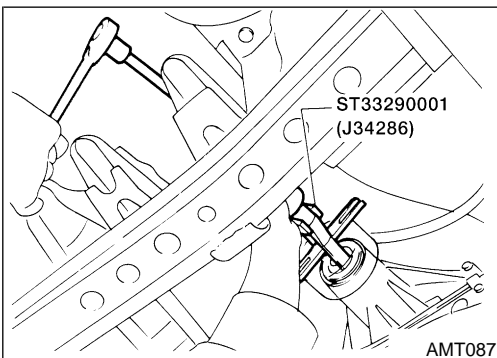

### REAR OIL SEAL

NGTF0004S03

1. Remove rear propeller shaft. Refer to **PD-8**, "Removal and Installation".
2. Remove rear oil seal.

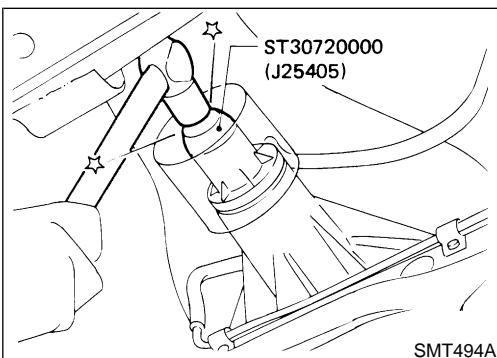

3. Install rear oil seal.
  - **Before installing apply multi-purpose grease to seal lip.**
4. Install rear propeller shaft. Refer to **PD-8**, "Removal and Installation".



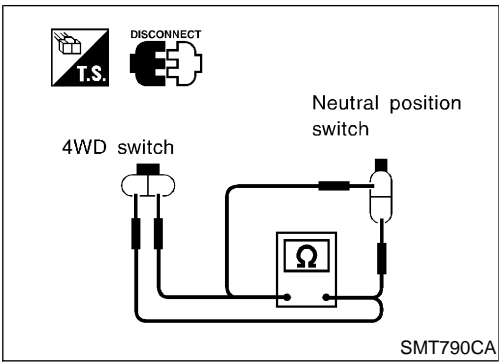

## Position Switch Check

NGTF0042

Switch	Gear Position	Continuity
4WD Switch	4WD	Yes
	Except 4WD	NO
Neutral Position Switch	Neutral	NO
	Except Neutral	Yes

GI

MA

EM

LC

EC

FE

CL

MT

AT

**TF**

PD

AX

SU

BR

ST

RS

BT

HA

SC

EL

IDX

# REMOVAL AND INSTALLATION

## Removal

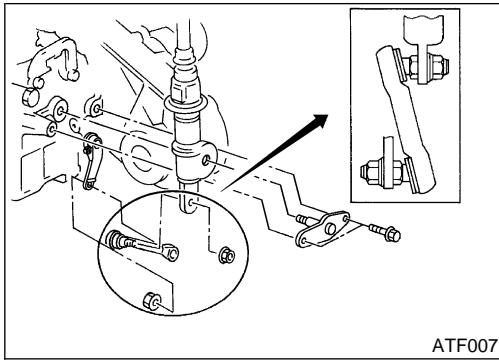

## Removal

NGTF0006

1. Drain fluid from transfer, and drain oil from transmission.
2. Remove front and rear propeller shaft. Refer to **PD-8**, "Removal and Installation".  
Insert plug into rear oil seal after removing propeller shaft.
- **Be careful not to damage spline, sleeve yoke and rear oil seal, when removing propeller shaft.**
3. Remove torsion bar spring. Refer to **SU-12**, "Torsion Bar Spring". Then remove second crossmember.
4. Remove exhaust front and rear tubes. Refer to **FE-9**, "EXHAUST SYSTEM".
5. Disconnect vehicle speed sensor, transfer neutral position switch and 4WD switch harness connectors.
6. Remove air breather hose.
7. Remove transfer control lever from transfer outer shift lever.
8. Separate transfer from transmission.

### WARNING:

**Support transfer while removing it.**

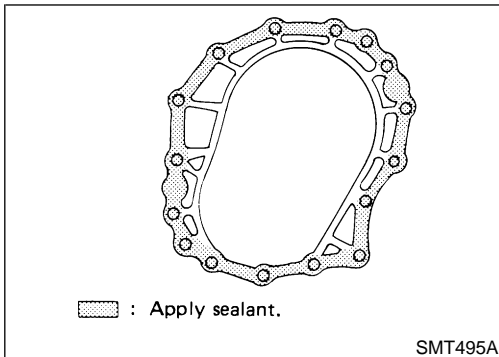

## Installation

NGTF0007

- Apply sealant to mating surface to transmission. (M/T model only)

**Use genuine anaerobic liquid gasket, Three Bond TB1215, Loctite Part No. 51813 or equivalent.**

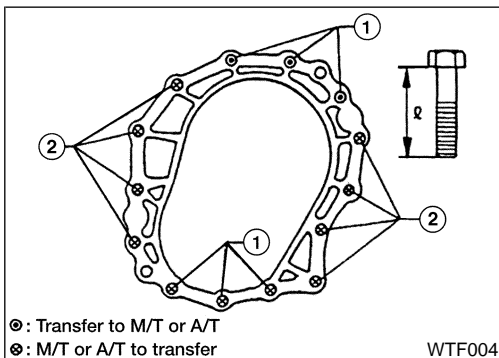

- Tighten bolts securing transfer.

### M/T MODEL

NGTF0007S01

Bolt No.	Tightening torque N·m (kg·m, ft·lb)	ℓ mm (in)
1	31 - 42 (3.2 - 4.3, 23 - 31)	60 (2.36)
2	31 - 42 (3.2 - 4.3, 23 - 31)	45 (1.77)

### A/T MODEL

NGTF0007S02

Bolt No.	Tightening torque N·m (kg·m, ft·lb)	ℓ mm (in)
1	31 - 42 (3.2 - 4.3, 23 - 31)	45 (1.77)
2	31 - 42 (3.2 - 4.3, 23 - 31)	45 (1.77)

- Adjust the torsion bars for the correct vehicle height. Refer to **SU-13**, "INSTALLATION AND ADJUSTMENT".

## Transfer Gear Control

SEC. 333

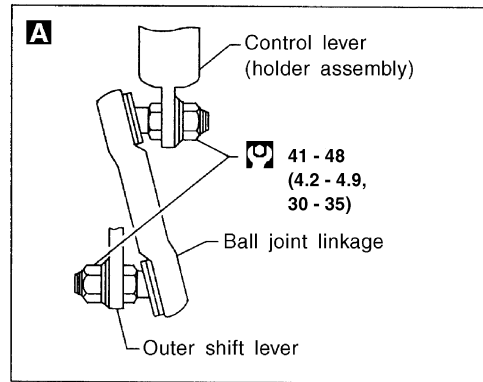
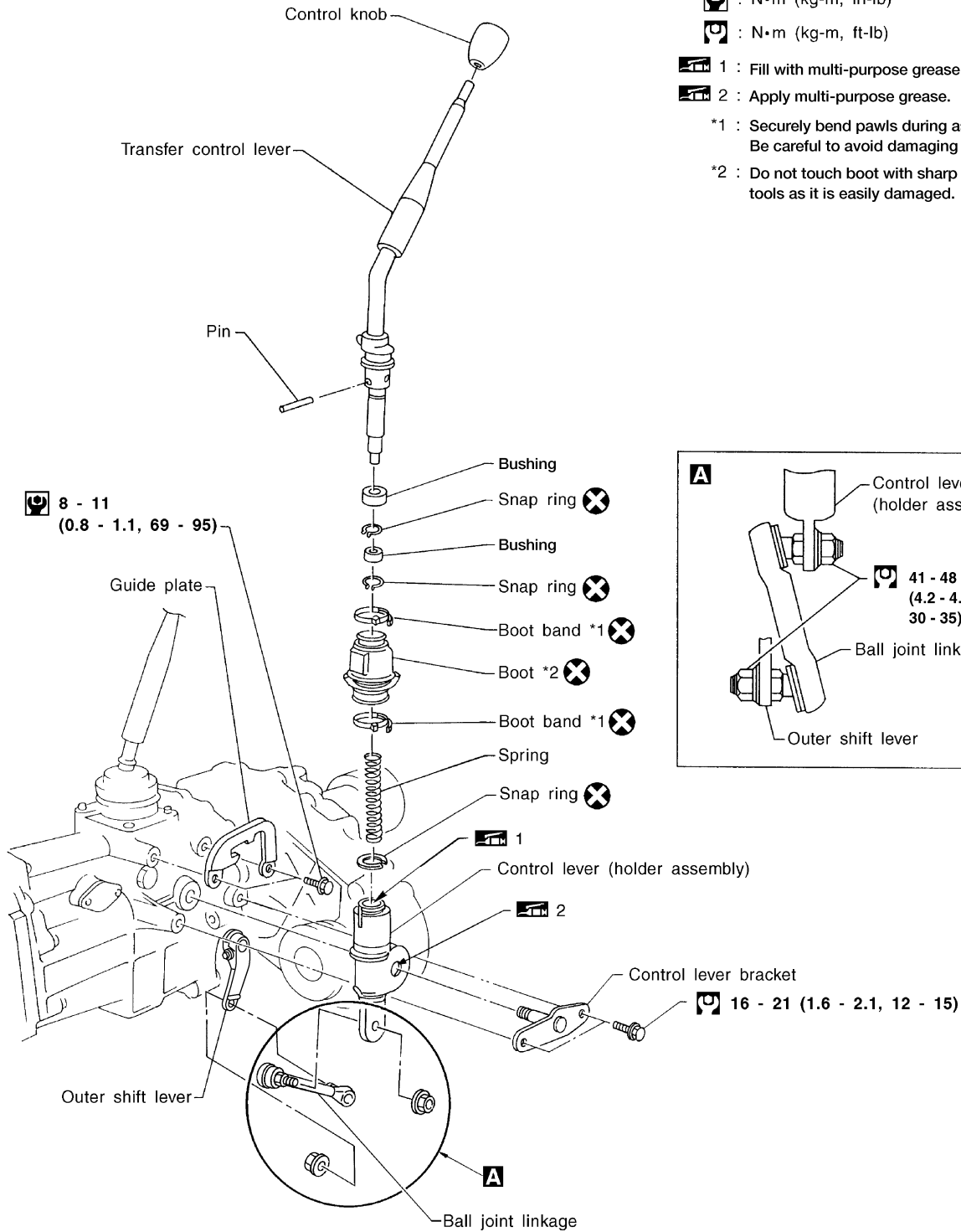

GI

MA

EM

LC

EC

FE

CL

MT

AT

TF

PD

AX

SU

BR

ST

RS

BT

HA

SC

EL

IDX



# OVERHAUL

NGTF0010

## Gear Components

GI  
MA  
EM  
LC  
EC  
FE  
CL  
MT  
AT  
TF  
PD  
AX  
SU  
BR  
ST  
RS  
BT  
HA  
SC  
EL  
IDX

SEC. 332

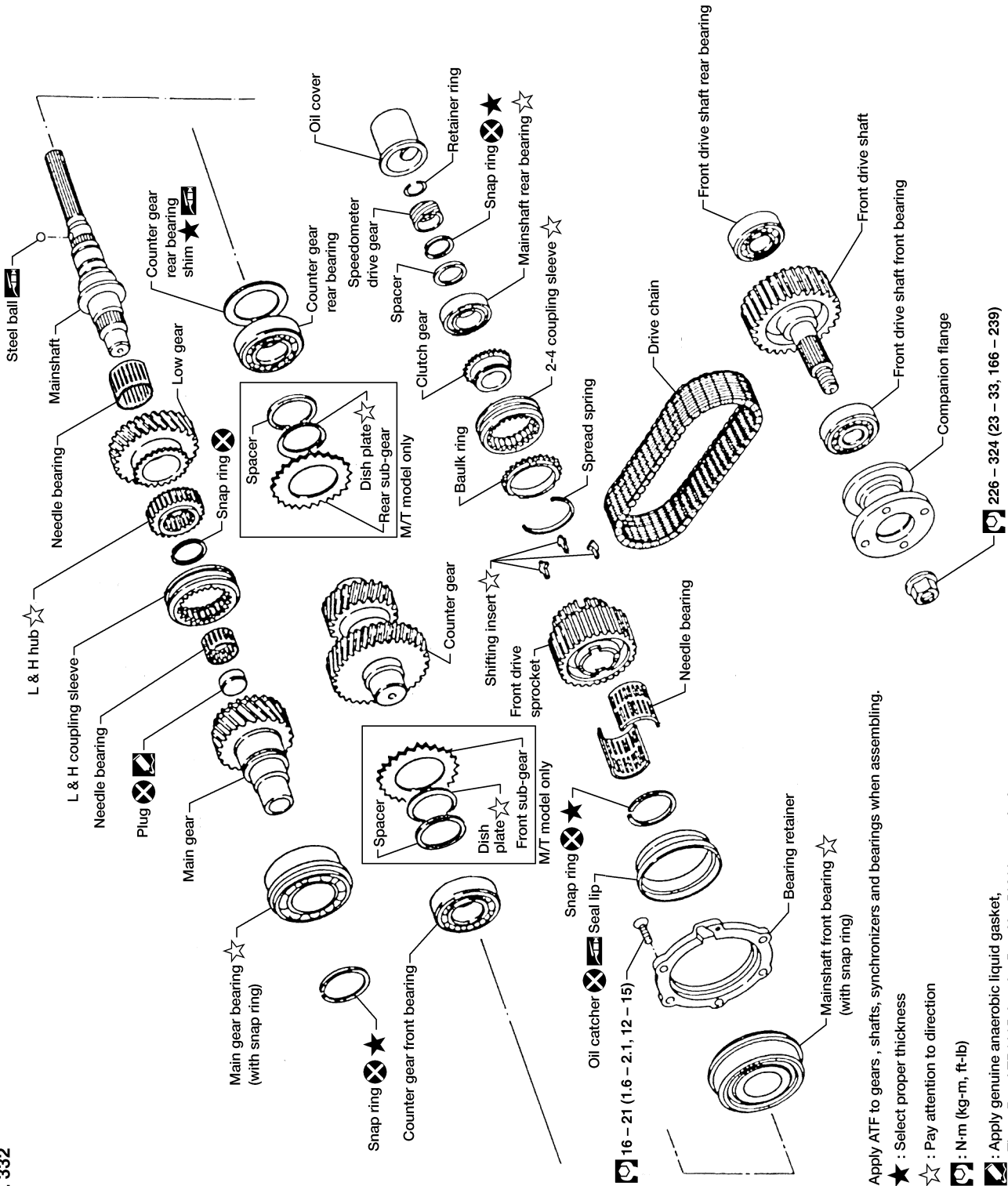

Apply ATF to gears, shafts, synchronizers and bearings when assembling.

★ : Select proper thickness

☆ : Pay attention to direction

⊗ : N·m (kg·m, ft·lb)

☑ : Apply genuine anaerobic liquid gasket, Three Bond TB1215, Loctite Part No. 51813 or equivalent.

226 - 324 (23 - 33, 166 - 239)

# OVERHAUL

## Shift Control Components

NGTF0011

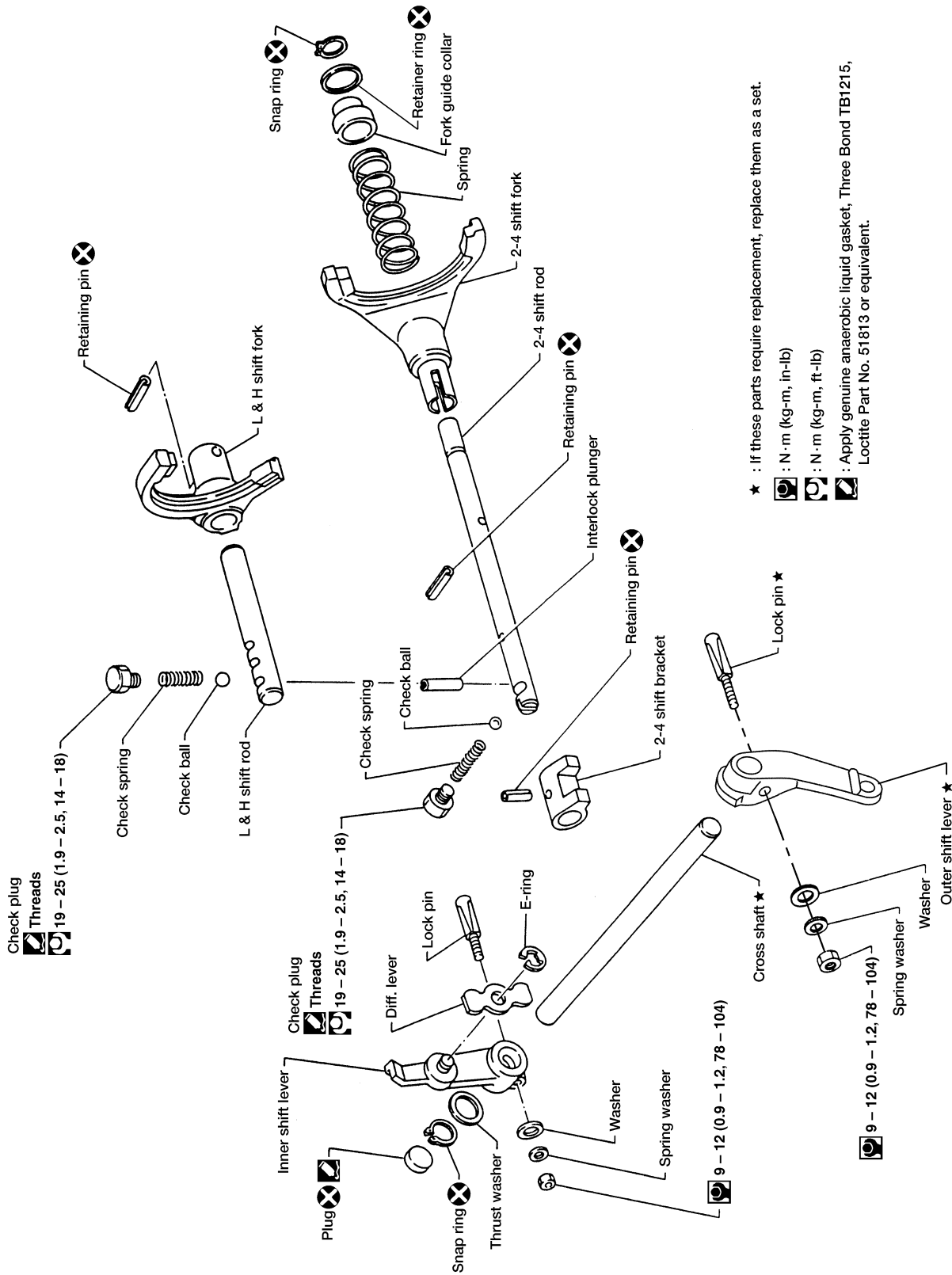

★ : If these parts require replacement, replace them as a set.

☐ : N·m (kg-m, in-lb)

☐ : N·m (kg-m, ft-lb)

☐ : Apply genuine anaerobic liquid gasket, Three Bond TB1215, Loctite Part No. 51813 or equivalent.

SEC. 333

# DISASSEMBLY

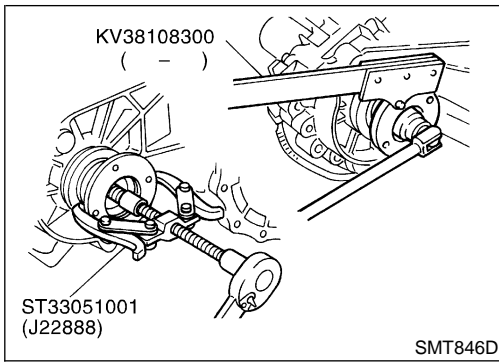

1. Remove companion flange nut.
2. Remove companion flange.

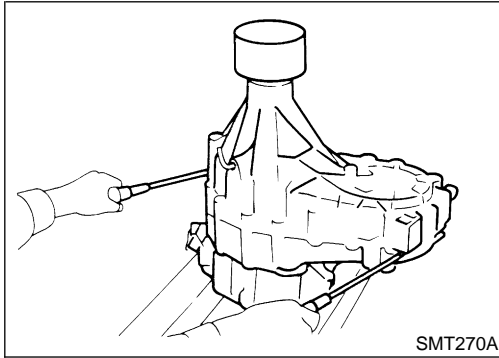

3. Remove 4WD switch.
4. Remove rear case.
  - Be careful not to damage the mating surface.

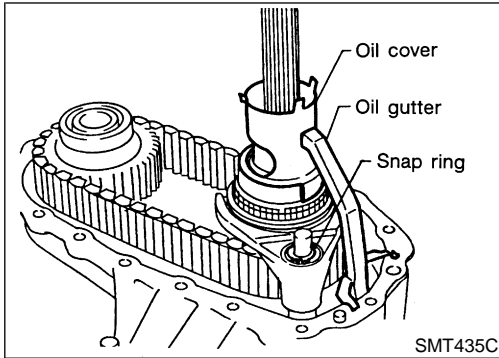

5. Remove oil cover and oil gutter.
6. Remove snap ring and retainer ring from 2-4 shift rod.

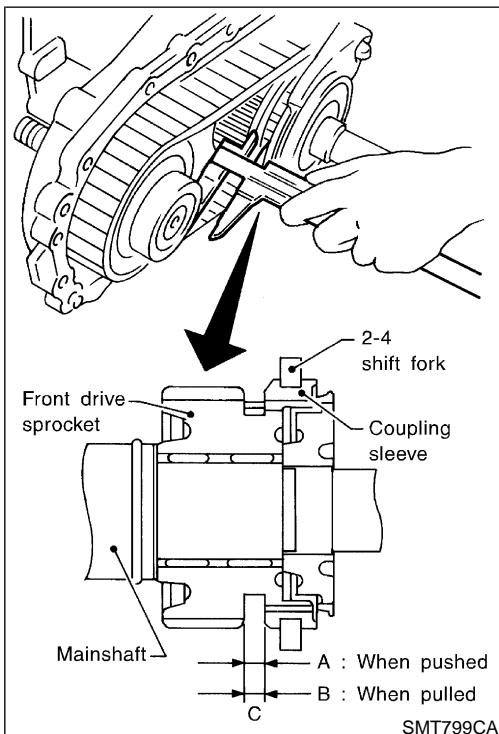

7. Using calipers, measure the difference between front drive sprocket and 2-4 coupling sleeve as outlined under measuring method below. If it is outside specifications, check front drive sprocket, 2-4 coupling sleeve, clutch gear, 2-4 shift fork and 2-4 fork rod for abnormalities. Replace faulty part(s) as required.

### Measuring method

Move Coupling sleeve until it is in contact with sprocket, then measure dimension A. Move coupling sleeve until it is in contact with clutch gear, then measure dimension B. Obtain dimension difference C between two measurements A and B.

$$A - B = C$$

To determine dimension A, measure at 3 or 4 different points by rotating sprocket and obtain average value of 3 or 4 measurements.

Specification C: Refer to "Clearance Between Front Drive Sprocket and 2-4 Coupling Sleeve", TF-37.

GI  
MA  
EM  
LC  
EC  
FE  
CL  
MT  
AT  
TF  
PD  
AX  
SU  
BR  
ST  
RS  
BT  
HA  
SC  
EL  
IDX

## DISASSEMBLY

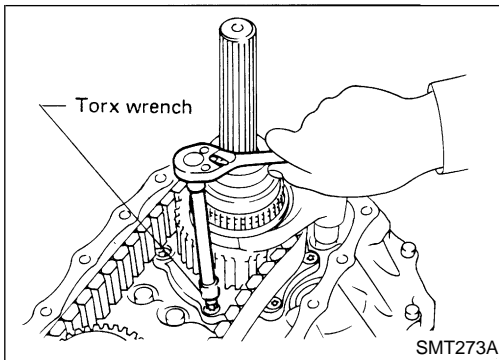

8. Remove bolts securing bearing retainer.
  - This step is necessary to remove mainshaft from center case.

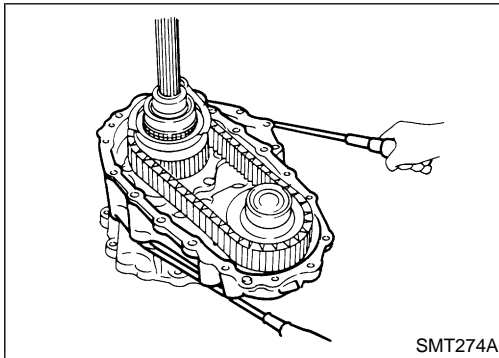

9. Remove bolts securing center case to front case and then separate center case and front case.

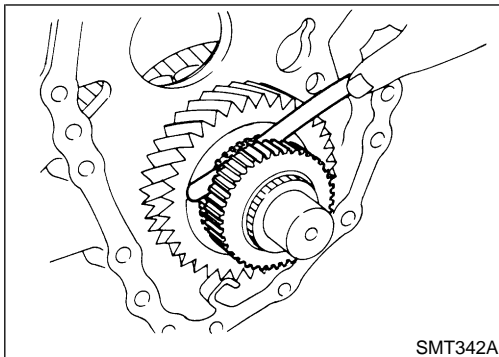

10. Measure low gear end play.

**Standard:**

**0.2 - 0.35 mm (0.0079 - 0.0138 in)**

- If end play is beyond the maximum value, check low gear and L & H hub for wear.

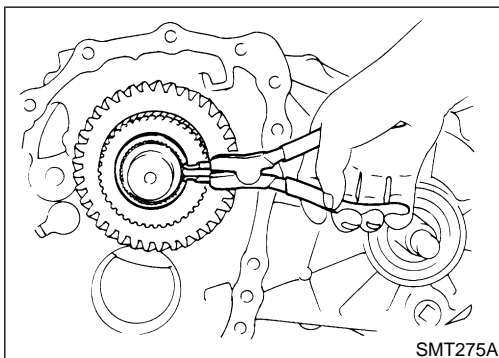

11. Disassemble center case assembly.
  - a. Remove snap ring from mainshaft.

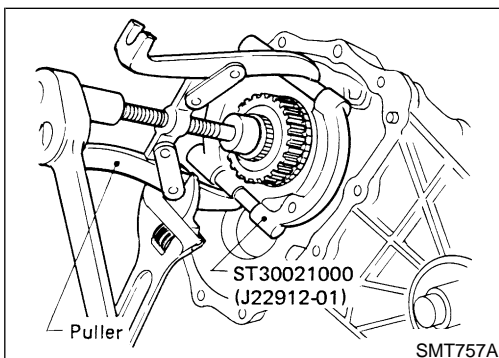

- b. Pull out low gear with L & H hub.



# DISASSEMBLY

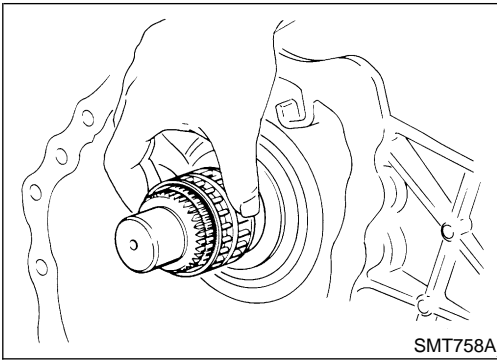

c. Remove needle bearing from main shaft.

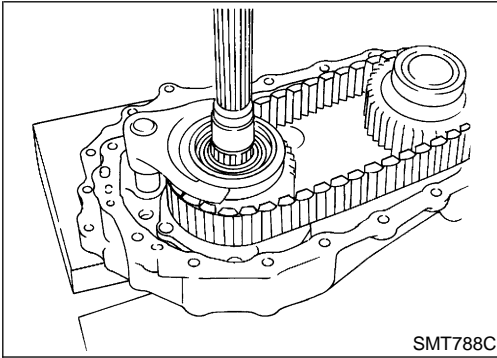

d. Make sure of the direction of the drive chain before removing it. (It must be reinstalled in the same direction.)

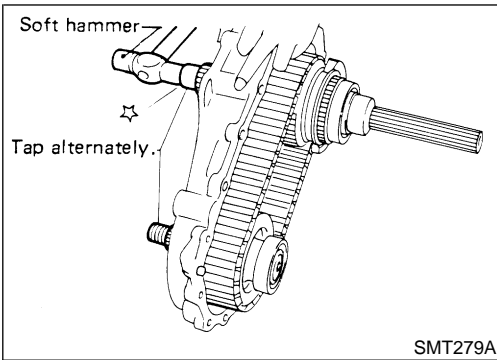

e. Remove mainshaft, front drive and drive chain as a set by tapping front end of mainshaft and front drive shaft alternately.  
● **Be careful not to bend drive chain.**

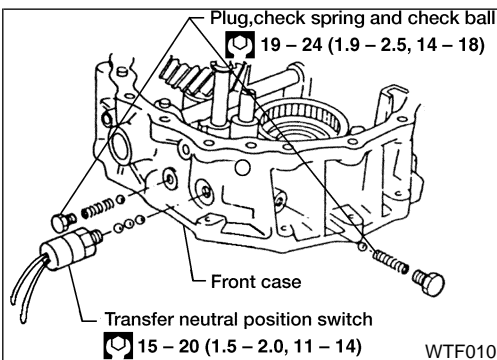

12. Disassemble front case assembly.

a. Remove transfer neutral position switch, plugs, check springs and check balls.

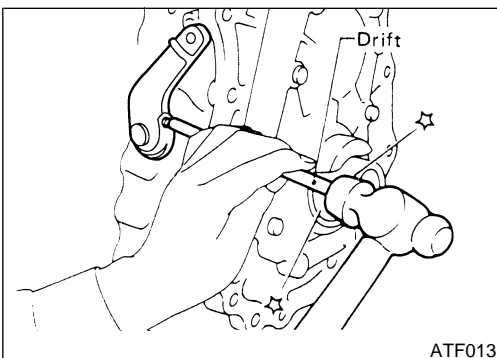

b. Remove lock pin from outer shift lever, then remove outer shift lever.

GI

MA

EM

LC

EC

FE

CL

MT

AT

TF

PD

AX

SU

BR

ST

RS

BT

HA

SC

EL

IDX

## DISASSEMBLY

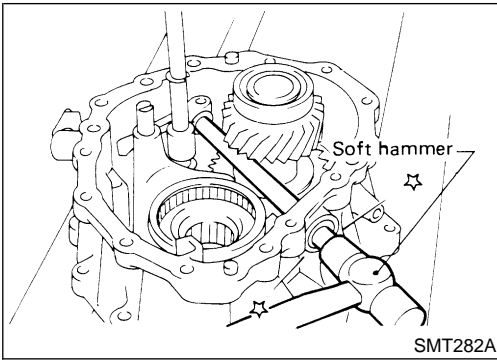

- c. Remove lock pin of inner shift lever and drive out cross shaft with plug.

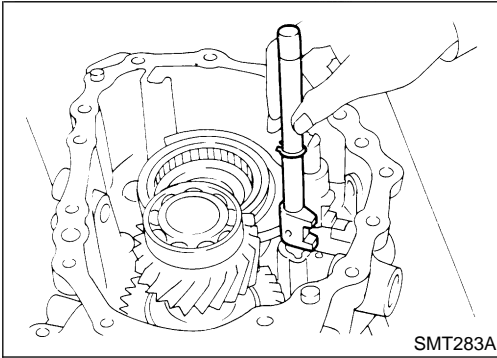

- d. Remove 2-4 shift rod.

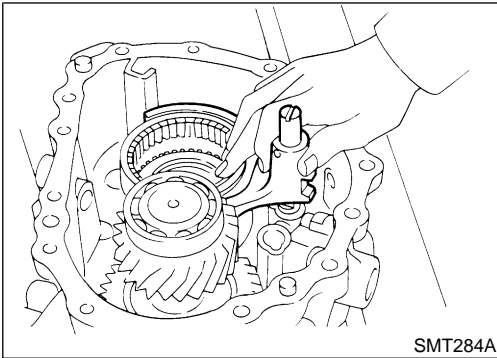

- e. Remove L & H shift rod and fork assembly with coupling sleeve.

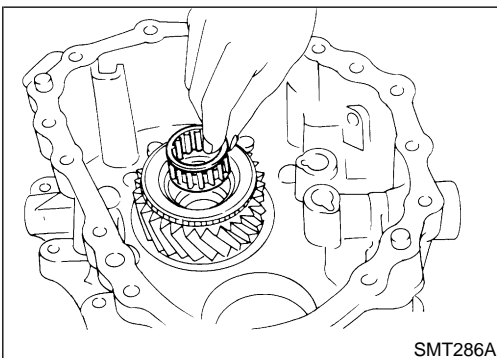

- f. Remove needle bearing from main gear.

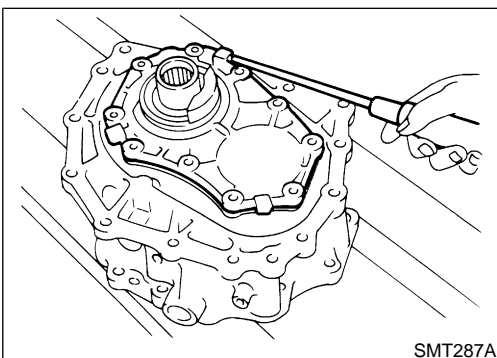

- g. Remove bolts securing front case cover and then remove case.

# DISASSEMBLY

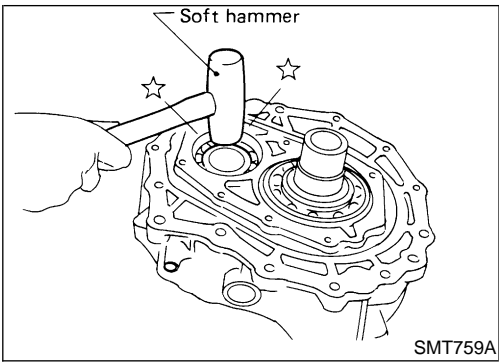

h. Remove counter gear by tapping lightly.

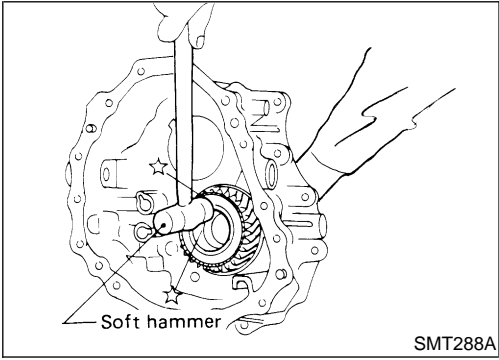

i. Remove main gear by tapping lightly.

GI

MA

EM

LC

EC

FE

CL

MT

AT

**TF**

PD

AX

SU

BR

ST

RS

BT

HA

SC

EL

IDX

# REPAIR FOR COMPONENT PARTS

## Mainshaft

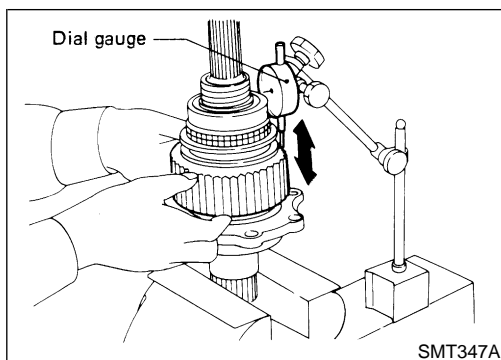

## Mainshaft DISASSEMBLY

NGTF0013

1. Check front drive sprocket end play.  
**Standard:**  
**0.2 - 0.35 mm (0.0079 - 0.0138 in)**
  - If end play is not within specification, check front drive sprocket and clutch gear for wear.

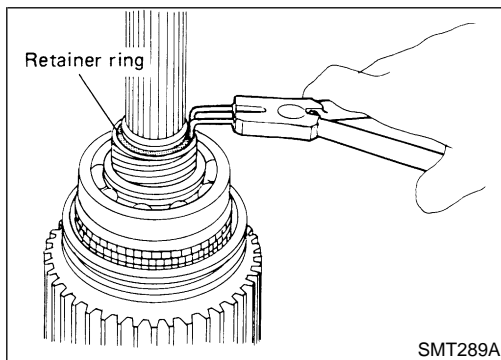

2. Remove retainer ring, speedometer drive gear and steel ball.
  - Be careful not to lose the steel ball.

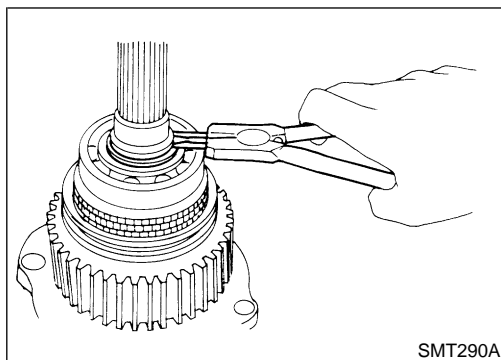

3. Remove snap ring and spacer.

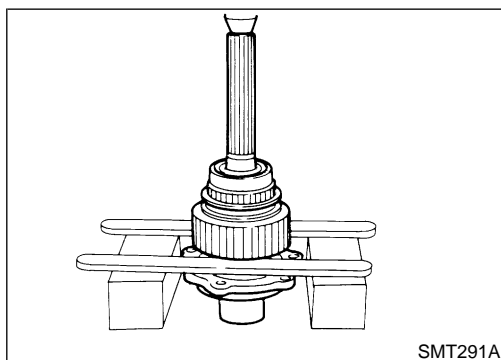

4. Use a press to remove front drive sprocket with mainshaft rear bearing and clutch gear together.
5. Remove needle bearing.

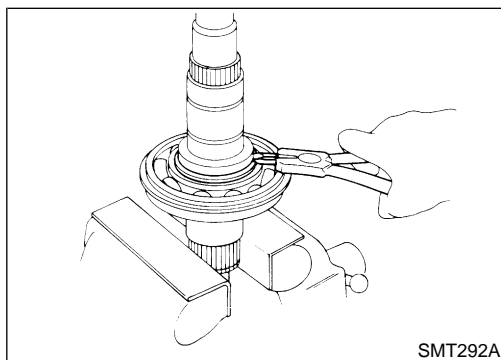

6. Remove bearing retainer and then remove snap ring.

# REPAIR FOR COMPONENT PARTS

Mainshaft (Cont'd)

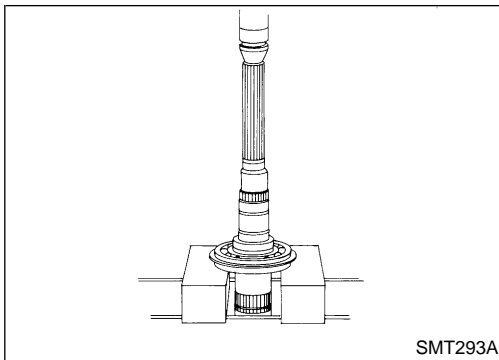

7. Use a press to remove mainshaft front bearing from mainshaft.

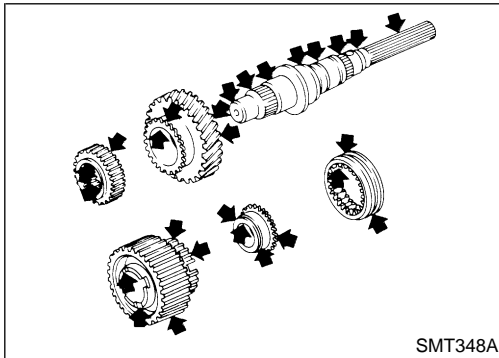

## INSPECTION

### Gear and Shaft

- Check gears for excessive wear, chips or cracks.
- Check shaft for cracks, wear or bending.
- Check coupling sleeve for wear or damage.

NGTF0014

NGTF0014S01

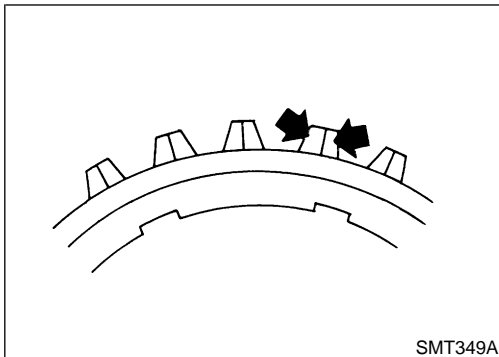

### Baulk ring

- Check baulk ring for cracks or deformation.

NGTF0014S03

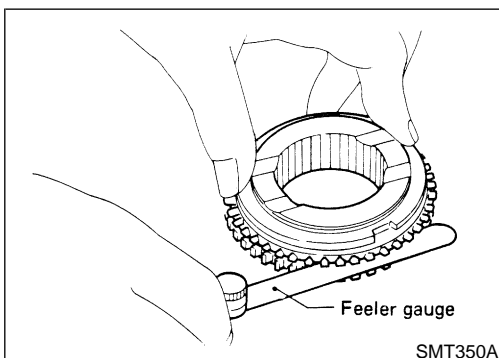

- Measure clearance between baulk ring and clutch gear.

### Baulk ring to clutch gear clearance:

Refer to "CLEARANCE BETWEEN BAULK RING AND CLUTCH GEAR", TF-37.

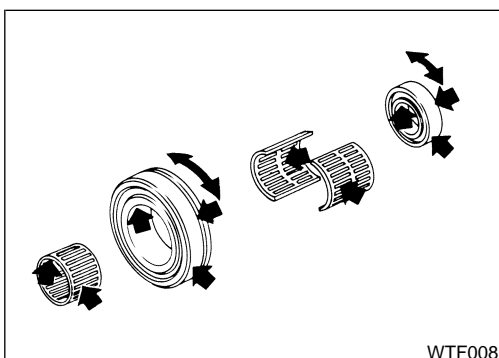

### Bearing

- Make sure bearings roll freely and are free from noise, cracks, pitting or wear.

NGTF0014S02

GI

MA

EM

LC

EC

FE

CL

MT

AT

TF

PD

AX

SU

BR

ST

RS

BT

HA

SC

EL

IDX

# REPAIR FOR COMPONENT PARTS

## Mainshaft (Cont'd)

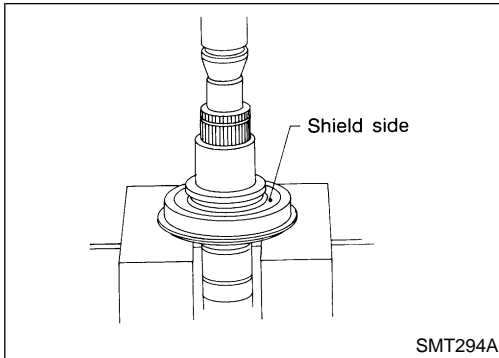

### ASSEMBLY

NGTF0015

1. Press mainshaft front bearing onto mainshaft.
  - Pay special attention to its direction.

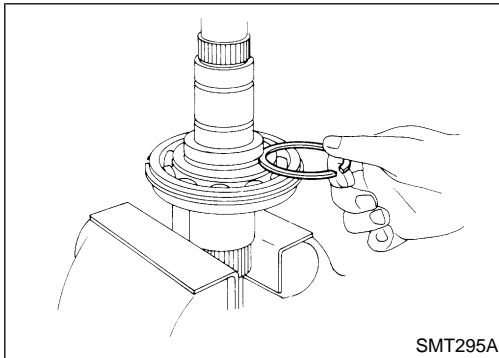

2. Select snap ring with proper thickness.
  - Allowable clearance between snap ring and groove:  
0 - 0.15 mm (0 - 0.0059 in)
  - Available snap ring for mainshaft front bearing:  
Refer to "MAINSHAFT FRONT BEARING", TF-37.
3. Regarding to further procedures, refer to "ASSEMBLY", TF-29.

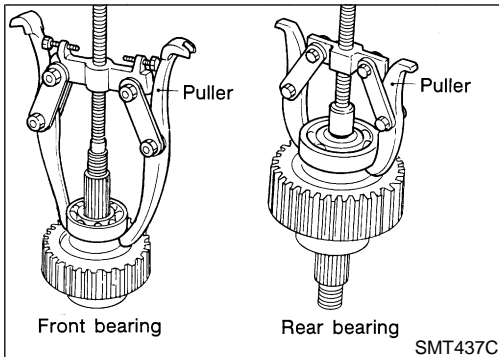

### Front Drive Shaft

#### DISASSEMBLY

NGTF0016

- Using a gear puller, remove front drive shaft front and rear bearings

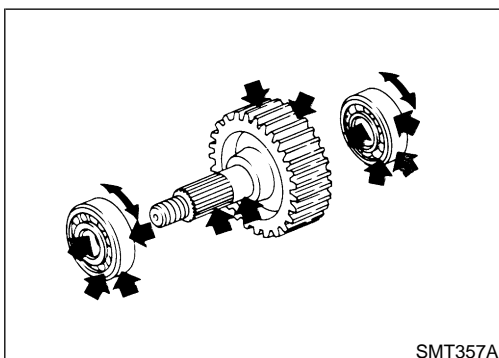

### INSPECTION

#### Sprocket and Shaft

NGTF0017

NGTF0017S01

- Check sprocket for excessive wear, chips or cracks.
- Check shaft for cracks or wear.

#### Bearing

NGTF0017S02

- Make sure bearings roll freely and are free from noise, cracks, pitting or wear.

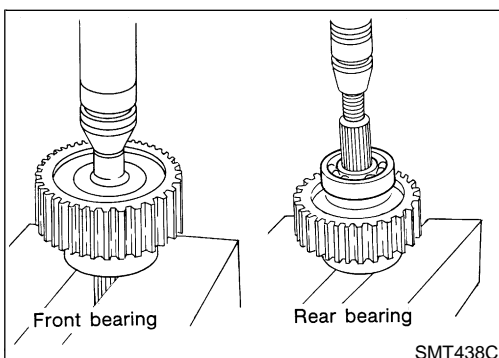

### ASSEMBLY

NGTF0018

- Press front drive shaft front and rear bearings onto front drive shaft.

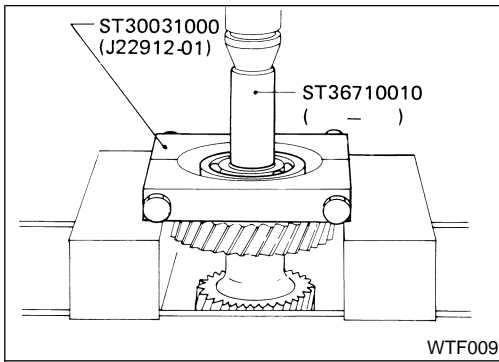

## Counter Gear DISASSEMBLY

NGTF0019

1. Press out counter gear front bearing.
- Remove front sub-gear, dish plate and spacer (M/T model only).

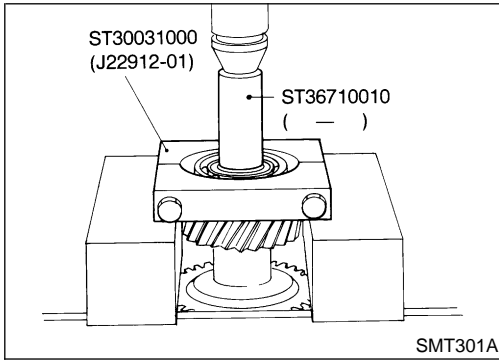

2. Press out counter gear rear bearing.
- Remove rear sub-gear, dish plate and spacer (M/T model only).

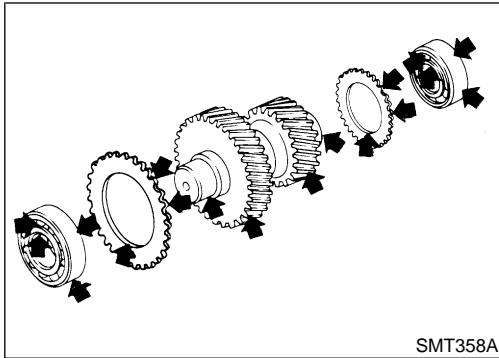

## INSPECTION

### Gear and Shaft

NGTF0020

- Check gears for excessive wear, chips or cracks.
- Check shaft for cracks or wear.

NGTF0020S01

### Bearing

- Make sure bearings roll freely and are free from noise, cracks, pitting or wear.

NGTF0020S02

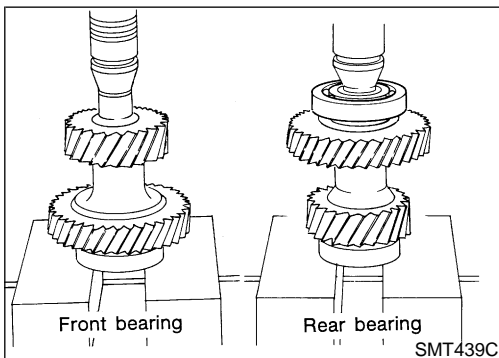

## ASSEMBLY

NGTF0021

1. Install front sub-gear, dish plate and spacer (M/T model only).
2. Press on counter gear front bearing.
3. Install rear sub-gear, dish plate and spacer (M/T model only).
4. Press on counter gear rear bearing.

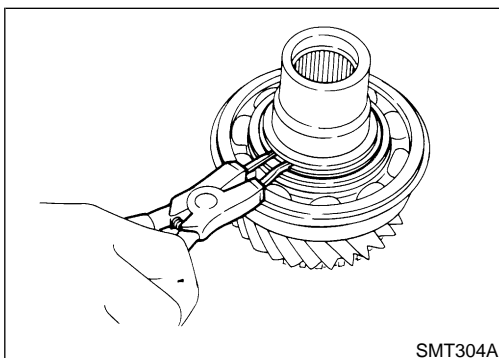

## Main Gear DISASSEMBLY Main Gear Bearing

NGTF0022

1. Remove snap ring.

NGTF0022S01

# REPAIR FOR COMPONENT PARTS

## Main Gear (Cont'd)

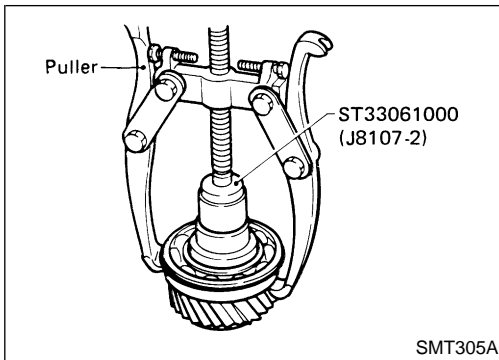

2. Pull out main gear bearing.

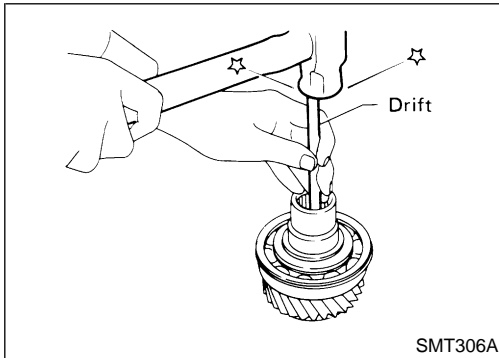

### Plug

- Always replace it with new one whenever it has been removed.

NGTF0022S02

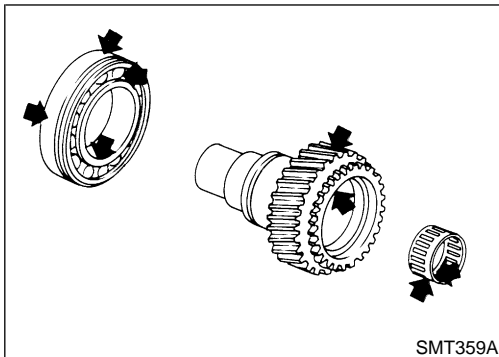

### INSPECTION

#### Gear and Shaft

- Check gears for excessive wear, chips or cracks.
- Check shaft for cracks or wear.

NGTF00023

NGTF0023S01

#### Bearing

- Make sure bearings roll freely and are free from noise, cracks, pitting or wear.

NGTF0023S02

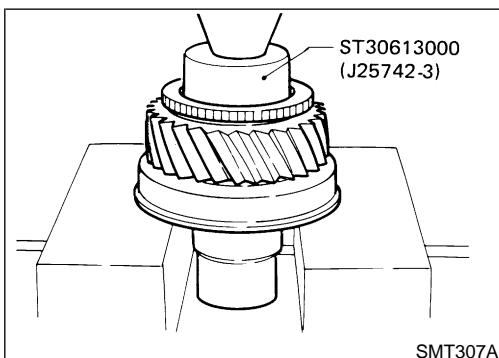

### ASSEMBLY

#### Main Gear Bearing

1. Press on main gear bearing.

NGTF00024

NGTF0024S01

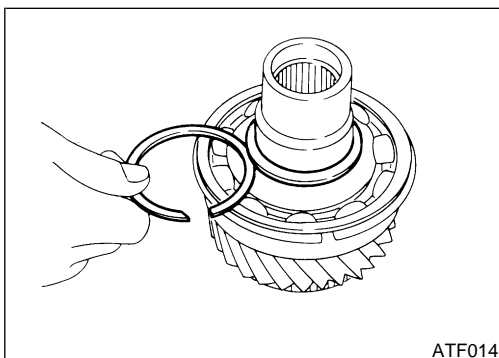

2. Select and install snap ring with proper thickness.

**Allowable clearance between snap ring and groove:**

**0 - 0.15 mm (0 - 0.0059 in)**

**Available snap ring for main gear bearing:**

**Refer to "MAIN GEAR BEARING", TF-38.**



# REPAIR FOR COMPONENT PARTS

Main Gear (Cont'd)

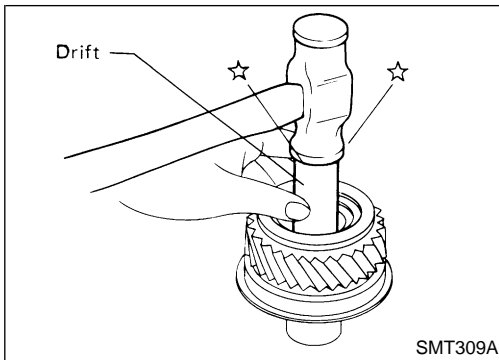

SMT309A

## Plug

Apply sealant to plug, then install.

NGTF0024S02

- Use genuine anaerobic liquid gasket, Three Bond TB1215, Loctite part No. 51813 or equivalent.

GI

MA

EM

LC

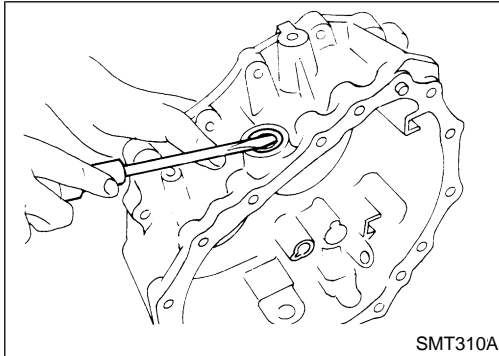

SMT310A

## Front Case

### REMOVAL

NGTF0025

### Shift Shaft Oil Seal

NGTF0025S01

- Use a screwdriver to pry out old seal.
- Be careful not to damage case.
- Always replace with a new one whenever it has been removed.

EC

FE

CL

MT

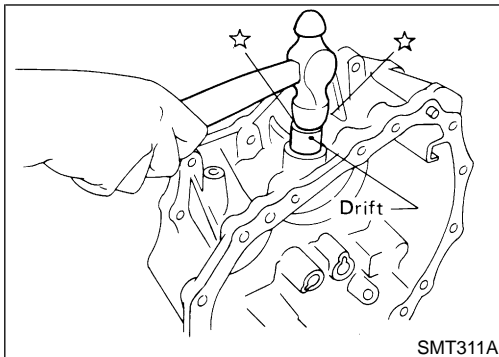

SMT311A

## INSTALLATION

### Shift Shaft Oil Seal

NGTF0026

NGTF0026S01

- Install new shift shaft oil seal until flush with case.
- Before installing, apply multi-purpose grease to seal lip.

AT

TF

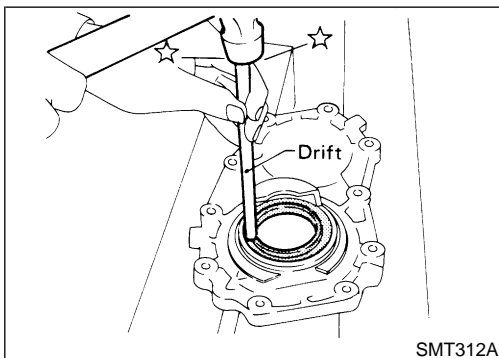

SMT312A

## Front Case Cover

### REMOVAL

NGTF0027

### Cover Oil Seal

NGTF0027S01

- Drive out old seal from inside of front case cover.
- Be careful not to damage front case cover.

PD

AX

SU

BR

ST

RS

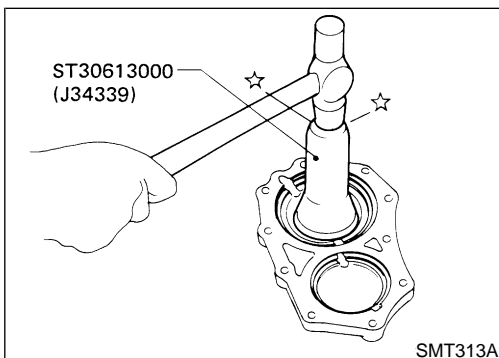

SMT313A

## INSTALLATION

### Cover Oil Seal

NGTF0028

NGTF0028S01

- Install new front case cover oil seal until it stops.
- Before installing, apply multi-purpose grease to seal lip.

BT

HA

SC

EL

IDX

# REPAIR FOR COMPONENT PARTS

## Bearing Retainer

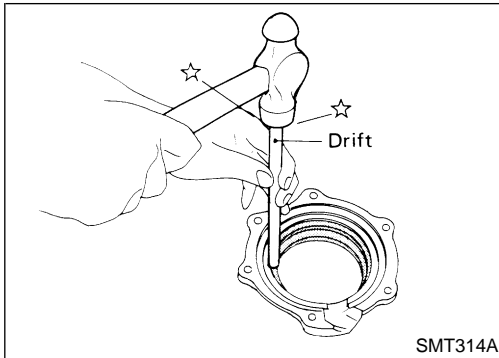

### Bearing Retainer

#### REMOVAL

#### Oil Catcher

- Drive out oil catcher from inside of bearing retainer.
- Be careful not to damage bearing retainer.

NGTF0029

NGTF0029S01

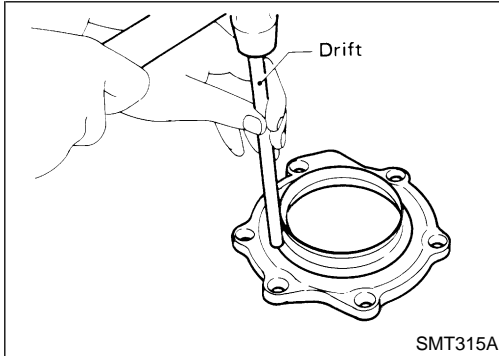

#### INSTALLATION

#### Oil Catcher

- Install oil catcher until it stops.
- Be careful not to damage or distort oil catcher or bearing retainer.
- Before installing, apply multi-purpose grease to seal lip.

NGTF0030

NGTF0030S01

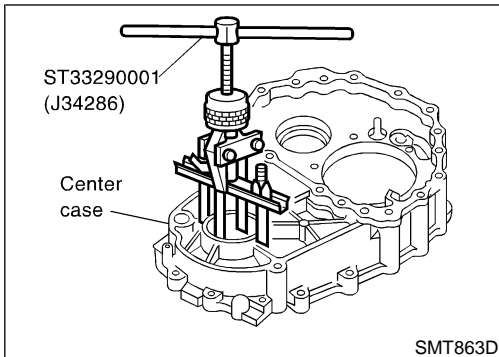

### Center Case

#### REMOVAL

#### Center Case Oil Seal

- Remove center case oil seal.

NGTF0044

NGTF0044S01

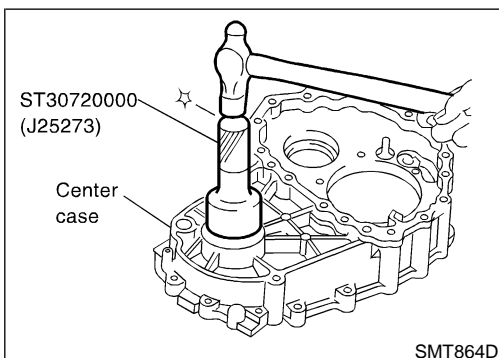

#### INSTALLATION

#### Center Case Oil Seal

- Install center case oil seal.

NGTF0045

NGTF0045S01

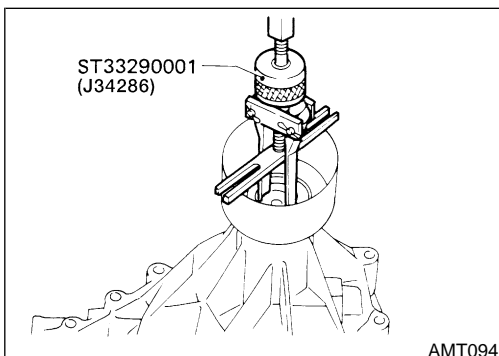

### Rear Case

#### REMOVAL

#### Rear Oil Seal

- Pull out rear oil seal.

NGTF0031

NGTF0031S01

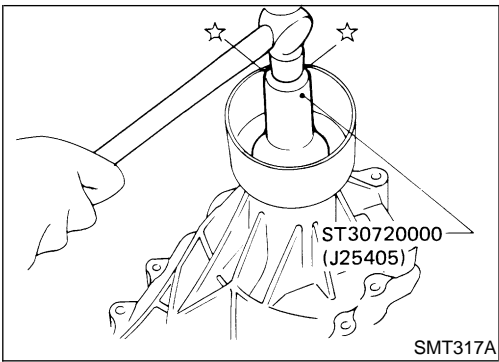

## INSTALLATION

### Rear Oil Seal

NGTF0032

NGTF0032S01

- Install new rear oil seal until it stops.
- Before installing, apply multi-purpose grease to seal lip.

GI

MA

EM

LC

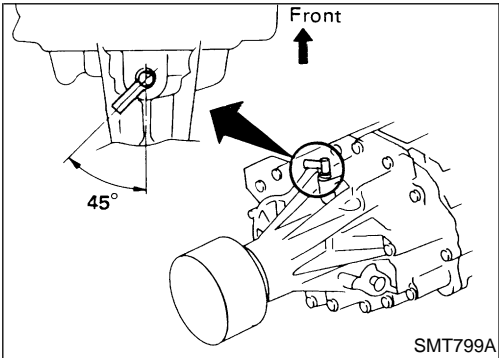

### Air Breather

NGTF0032S02

Install as shown in illustration.

EC

FE

CL

MT

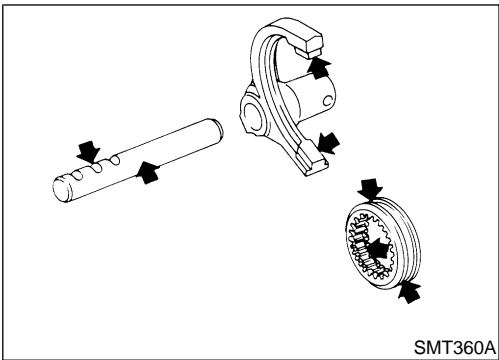

## Shift Control Components

### INSPECTION

NGTF0033

- Check contact surface and sliding surface for wear, scratches, projections or other faulty conditions.

AT

TF

PD

AX

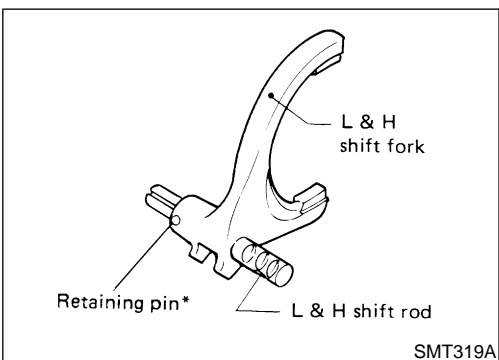

### L & H Shift Rod & Fork

NGTF0033S01

- Assemble as shown in illustration.  
\* Retaining pin is the same size as the one for 2-4 shift rod.

SU

BR

ST

RS

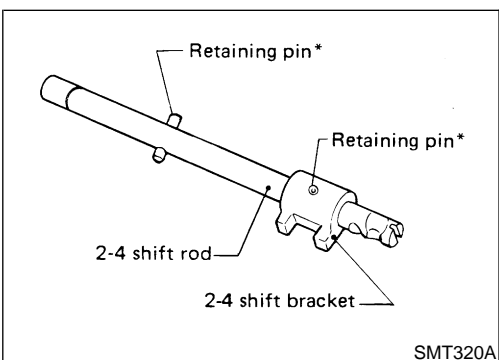

### 2-4 Shift Rod & Fork

NGTF0033S02

- Assemble as shown in illustration.  
\* Retaining pins are the same size.

BT

HA

SC

EL

IDX

## REPAIR FOR COMPONENT PARTS

### Shift Control Components (Cont'd)

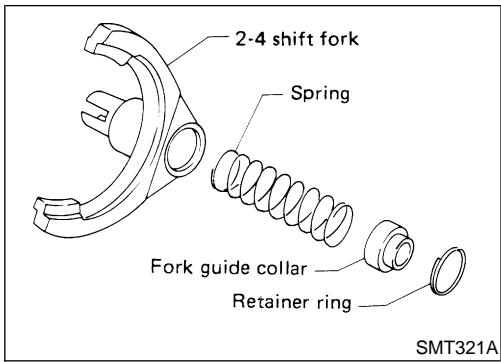

- Pay special attention to the direction of fork guide collar.

# ASSEMBLY

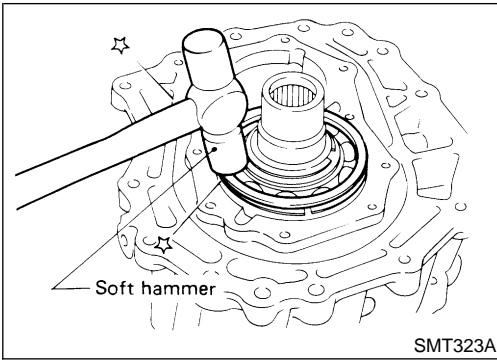

1. Assemble front case.
  - a. Install main gear assembly by tapping lightly.

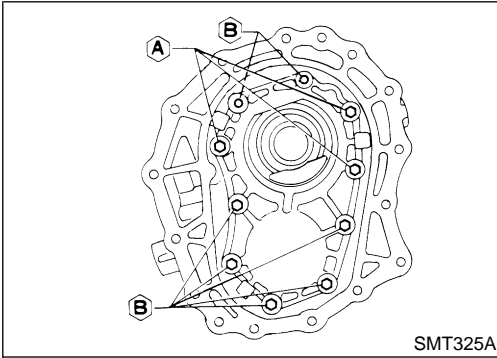

- b. Apply sealant to the mating surface and bolts of front case cover, then attach it to the front case.
      - Use genuine anaerobic liquid gasket, Three Bond TB1215, Loctite Part No. 51813 or equivalent.
      - These ten bolts should be coated with sealant.
        - Bolts A: 20 - 24 N·m (2.0 - 2.4 kg·m, 14 - 17 ft·lb)
        - Bolts B: 24 - 28 N·m (2.4 - 2.9 kg·m, 17 - 21 ft·lb)

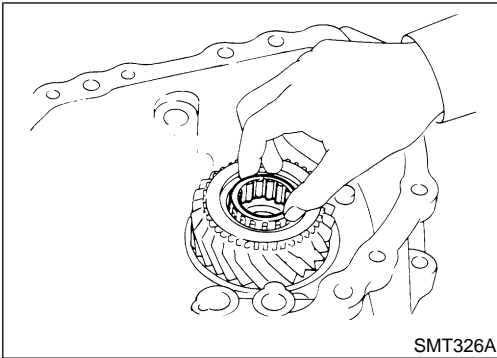

- c. Apply ATF to needle bearing and install it into main gear.

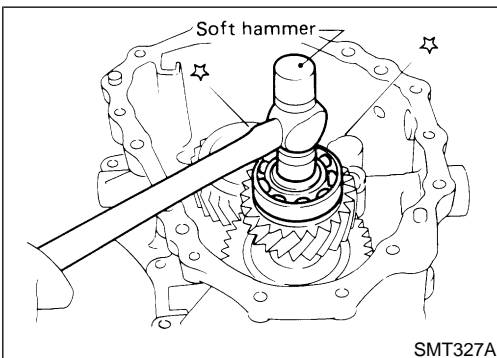

- d. Install counter gear assembly by tapping lightly.

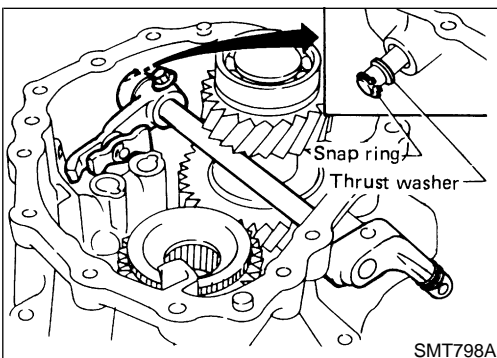

- e. Install cross shaft and inner shift lever.
        - When replacing cross shaft, outer shift lever or outer shift lever lock pin, replace them as a set.

GI  
MA  
EM  
LC  
EC  
FE  
CL  
MT  
AT  
TF  
PD  
AX  
SU  
BR  
ST  
RS  
BT  
HA  
SC  
EL  
IDX

## ASSEMBLY

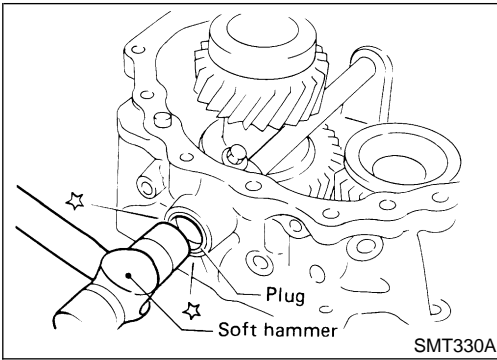

- f. Apply sealant to plug and install it into front case.  
**Use genuine anaerobic liquid gasket, Three Bond TB1215, Loctite Part No. 51813 or equivalent.**

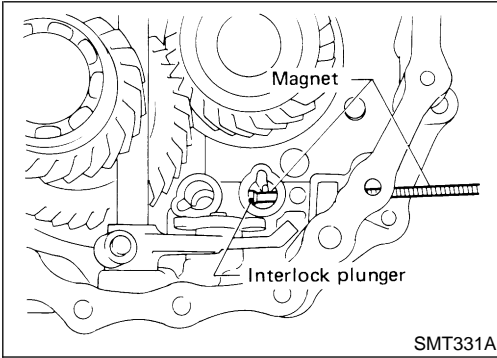

- g. Insert interlock plunger into front case.

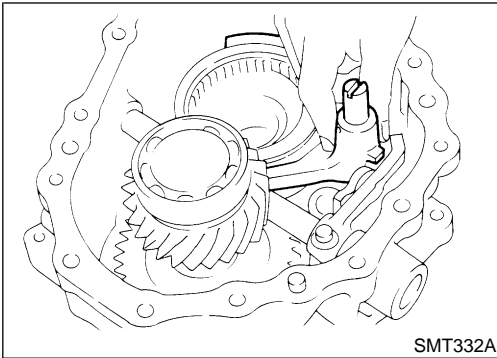

- h. Install L & H shift rod and fork assembly with coupling sleeve.

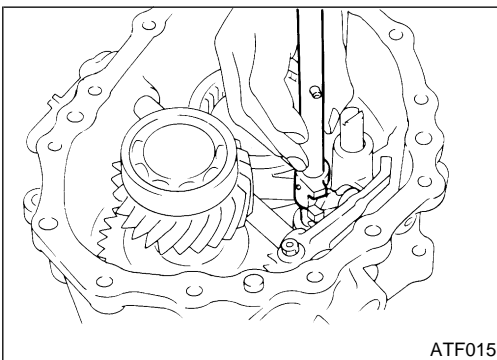

- i. Install 2-4 shift rod.

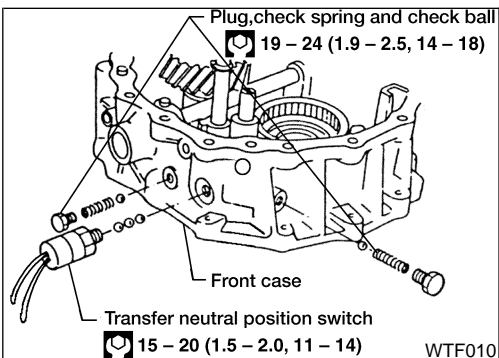

- j. Install transfer neutral position switch, check balls, check springs and plugs.
- **Apply sealant to switches and plugs.**
  - **Use genuine anaerobic liquid gasket, Three Bond TB1215, Loctite Part No. 51813 or equivalent.**

# ASSEMBLY

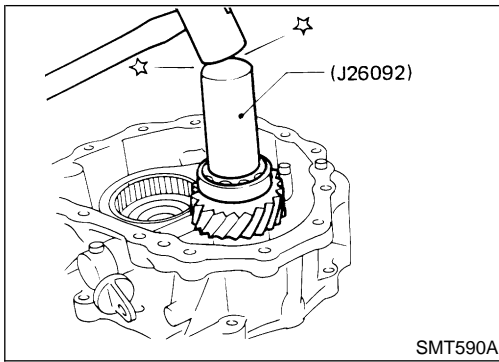

2. Select counter gear rear bearing shim.
  - a. Seat counter gear assembly.

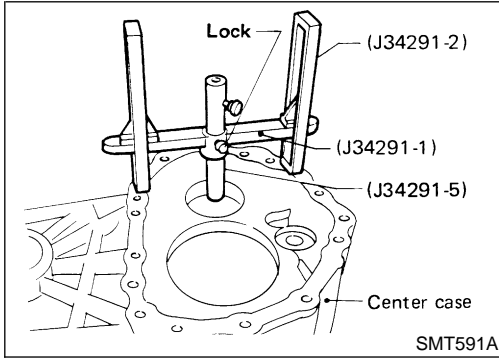

- b. Place J34291-1 (bridge), J34291-2 (legs) and J34291-5 (gauging cylinder) on machined surface of center case, allowing gauging cylinder to rest on top outer portion of counter gear rear bearing. Lock gauging cylinder in place.

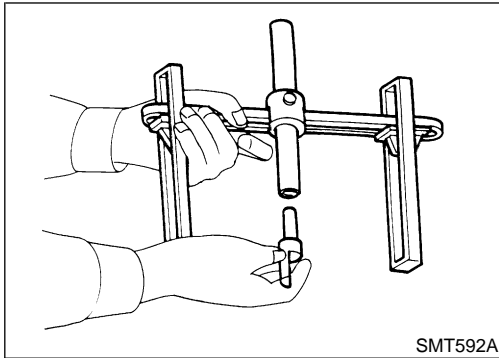

- c. Insert J34291-20 (gauging plunger) into J34291-5 (gauging cylinder).

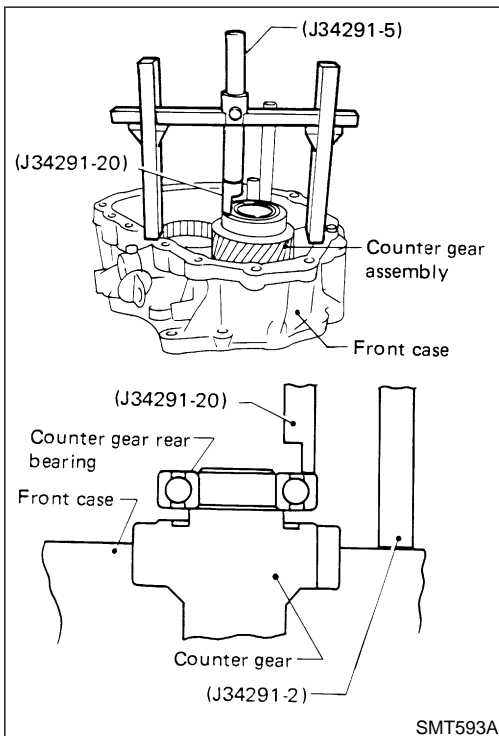

- d. Place bridge, legs, gauging cylinder and gauging plunger onto machined surface of front case assembly, allowing gauging plunger to drop until it contacts counter gear rear bearing mating surface.

GI

MA

EM

LC

EC

FE

CL

MT

AT

TF

PD

AX

SU

BR

ST

RS

BT

HA

SC

EL

IDX

## ASSEMBLY

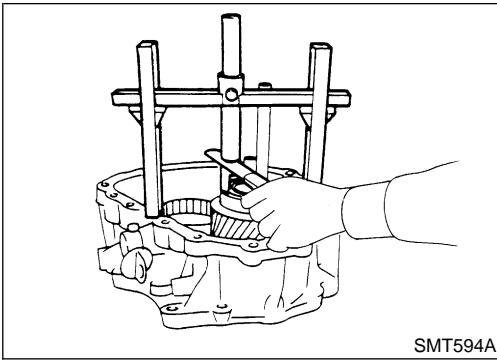

- e. Lock gauging plunger in place and use feeler gauge to measure end play between gauging cylinder and gauging plunger.
- f. Use measured distance to select correct counter gear rear bearing shim.

**Allowable counter gear end play:**

**0 - 0.2 mm (0 - 0.008 in)**

**Allowable counter gear rear bearing shim:**

**Refer to "COUNTER GEAR REAR BEARING", TF-37.**

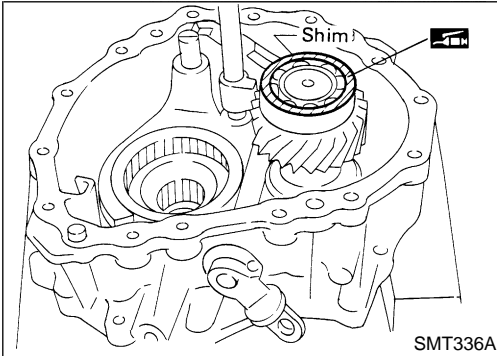

3. Place suitable shim with grease on counter gear rear bearing.
4. Apply ATF to each part in front case.

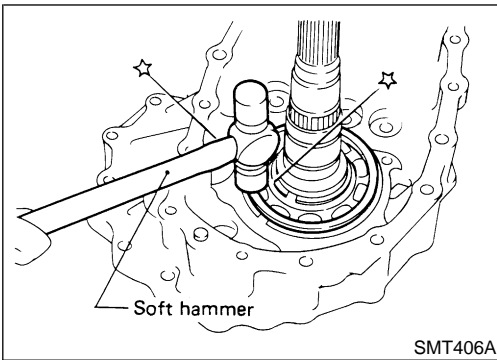

5. Assemble center case assembly.
  - a. Install mainshaft on center case by tapping lightly.
    - **Apply ATF to mainshaft front bearing.**

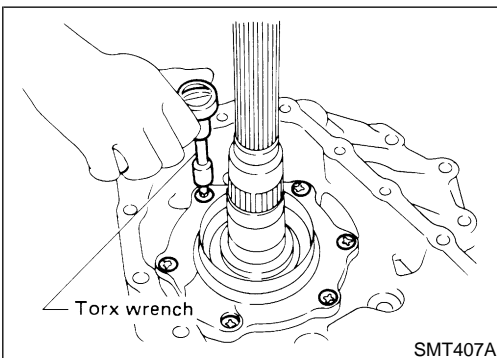

- b. Install bearing retainer.

 : 16 - 21 N·m (1.6 - 2.1 kg·m, 12 - 15 ft·lb)



# ASSEMBLY

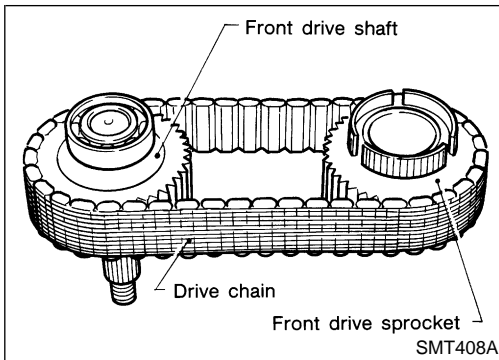

- c. Put drive chain onto the front drive sprocket and front drive shaft, and then put them in center case.

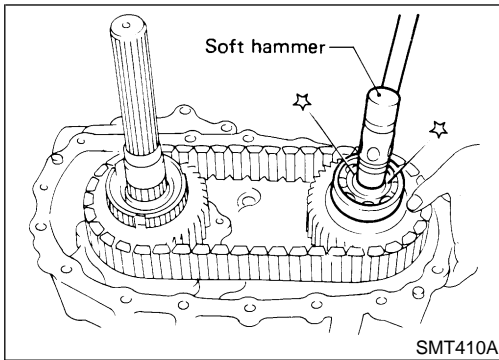
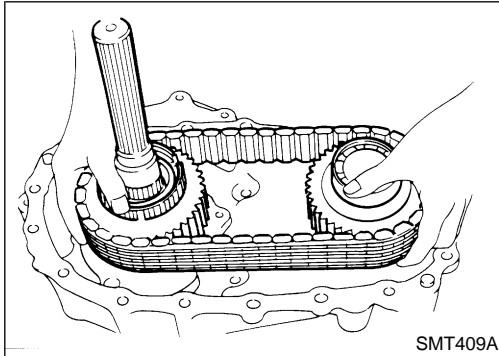

- d. Install front drive shaft by tapping lightly.  
 ● **Make sure shafts are aligned in the case.**

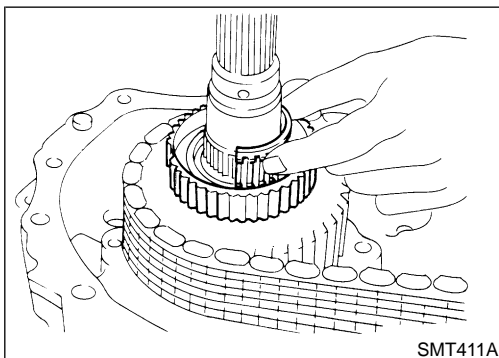

- e. Apply ATF to needle bearings and install them into front drive sprocket.  
 ● **These needle bearings can be installed more easily if front drive sprocket is rotated while installing them.**

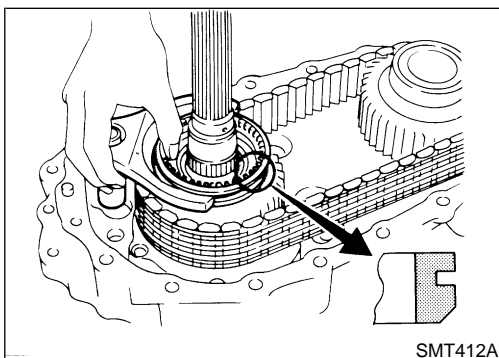

- f. Install 2-4 coupling sleeve with 2-4 shift fork.  
 ● **Pay special attention to direction of coupling sleeve.**

GI

MA

EM

LC

EC

FE

CL

MT

AT

TF

PD

AX

SU

BR

ST

RS

BT

HA

SC

EL

IDX

## ASSEMBLY

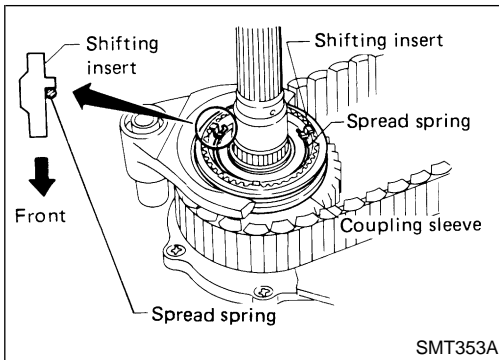

- g. Install shifting inserts and spread spring.
- **Pay attention to the direction of shifting inserts.**

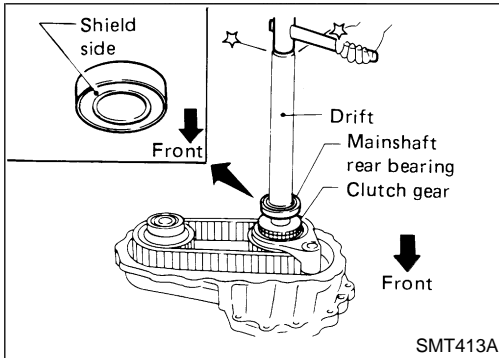

- h. Install baulk ring, then install clutch gear and mainshaft rear bearing.
- **Place wooden block under mainshaft in order to protect mainshaft front bearing.**

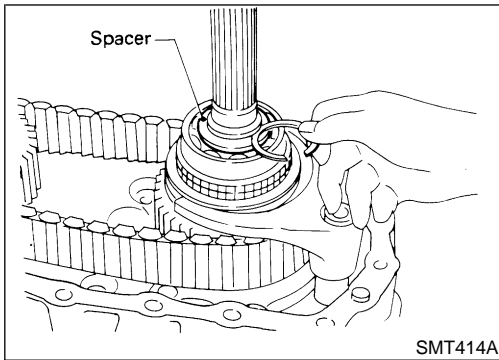

- i. Install spacer.
- j. Select and install snap ring with proper thickness.
- Allowable clearance between snap ring and groove:  
0 - 0.15 mm (0 - 0.0059 in)**
- Available snap ring for mainshaft rear bearing:  
Refer to "MAINSHAFT REAR BEARING", TF-38.**

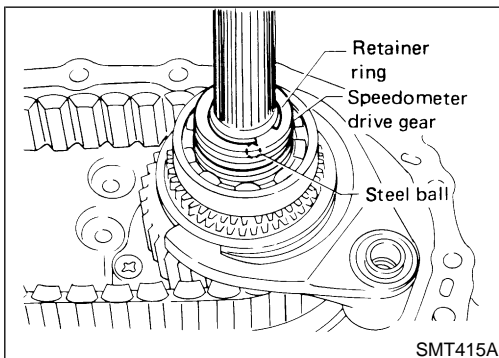

- k. Install steel ball, speedometer drive gear and retainer ring.
- **Steel ball is the smallest of check balls for this unit.**

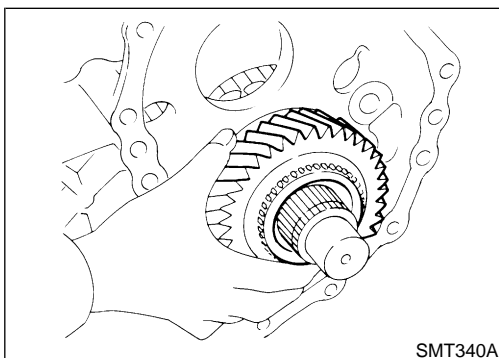

- l. Install low gear and its bearing onto mainshaft.
- **Apply ATF to needle bearing.**

# ASSEMBLY

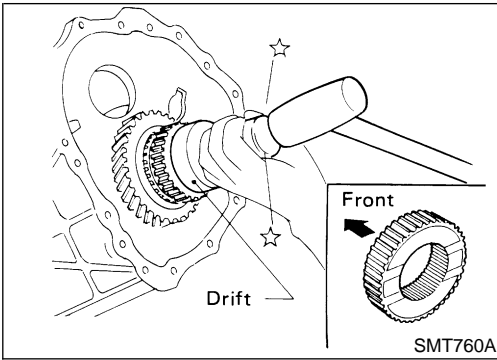

- m. Install L & H hub and snap ring to mainshaft.
- Pay attention to direction of L & H hub.

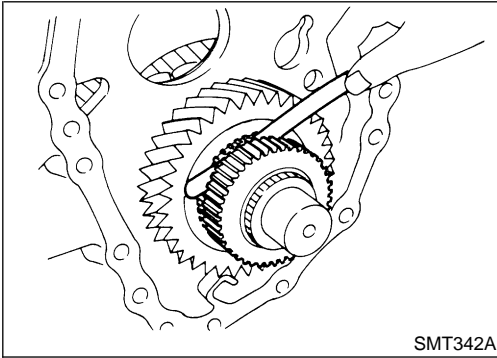

- n. Measure low gear end play.
- Standard:**  
**0.2 - 0.35 mm (0.0079 - 0.0138 in)**

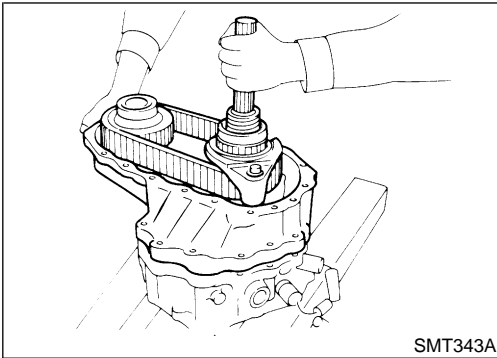

6. Apply sealant to mating surface of center case then attach to front case and tighten bolts.
- Use genuine anaerobic liquid gasket, **Three Bond TB1215**, **Loctite Part No. 51813** or equivalent.

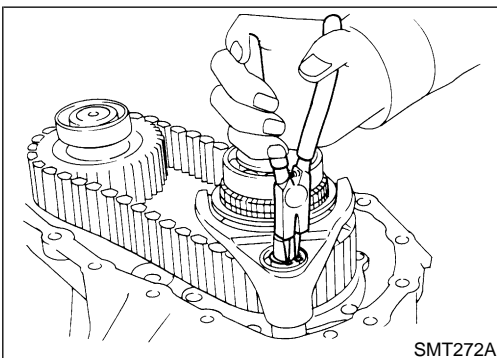

7. Install snap ring to 2-4 shift rod.

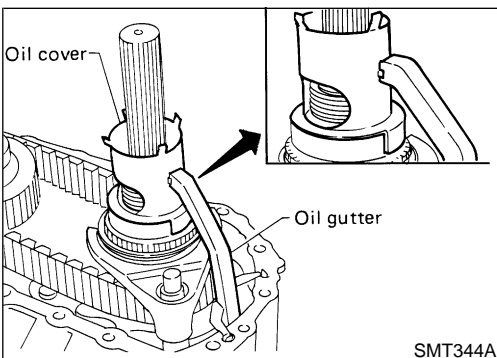

8. Install oil gutter and oil cover.
9. Apply ATF to each part in center case.

GI

MA

EM

LC

EC

FE

CL

MT

AT

TF

PD

AX

SU

BR

ST

RS

BT

HA

SC

EL

IDX

## ASSEMBLY

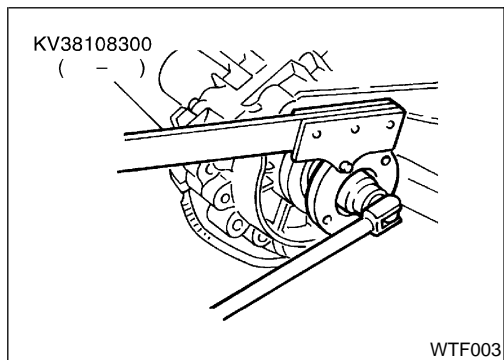
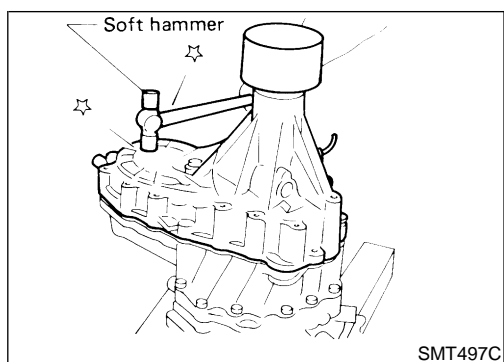

10. Apply sealant to mating surface of rear case then attach it to center case and tighten bolts.
  - Use genuine anaerobic liquid gasket, Three Bond TB1215, Loctite Part No. 51813 or equivalent.
11. Install 4WD switch.
  - Apply sealant to switch threads.
  - Use genuine anaerobic liquid gasket, Three Bond TB1215, Loctite Part No. 51813 or equivalent.
12. Install the companion flange and the companion flange nut.
  - Tighten the companion flange to specification. Refer to “Gear Components”, TF-13.

# SERVICE DATA AND SPECIFICATIONS (SDS)

General Specifications

## General Specifications

NGTF0035

Transfer model			TX10A	
Gear ratio	High	1.000		
	Low	2.020		
Number of teeth	Main gear	29		
	Low gear	37		
	Counter gear	High	38	
		Low	24	
	Front drive sprocket	41		
Front drive shaft	41			
Fluid capacity ℓ (US qt, Imp qt)			2.2 (2-3/8, 2)	

## Inspection and Adjustment

### CLEARANCE BETWEEN FRONT DRIVE SPROCKET AND 2-4 COUPLING SLEEVE

NGTF0040

NGTF0040S01  
Unit: mm (in)

Allowable clearance "C"	0.2 - 0.54 (0.008 - 0.0213)
-------------------------	-----------------------------

### GEAR END PLAY

NGTF0040S02  
Unit: mm (in)

Front drive sprocket	0.2 - 0.35 (0.008 - 0.0138)
Low gear	0.2 - 0.35 (0.008 - 0.0138)
Counter gear	0 - 0.2 (0 - 0.008)

### CLEARANCE BETWEEN BAULK RING AND CLUTCH GEAR

NGTF0040S03  
Unit: mm (in)

Standard	Wear limit
1.0 - 1.5 (0.039 - 0.059)	0.5 (0.020)

## Available Shim

### COUNTER GEAR REAR BEARING

NGTF0040S04

NGTF0040S0401

Allowable clearance	0 - 0.2 mm (0 - 0.008 in)
Thickness mm (in)	Part No.*
0.1 (0.004)	33112-C6900
0.2 (0.008)	33112-C6901
0.3 (0.012)	33112-C6902
0.4 (0.016)	33112-C6903
0.5 (0.020)	33112-33G00
0.6 (0.024)	33112-33G01

\*: Always check with the Parts Department for the latest parts information.

## Available Snap Ring

### MAINSHAFT FRONT BEARING

NGTF0040S05

NGTF0040S0501

Allowable clearance	0 - 0.15 mm (0 - 0.0059 in)
Thickness mm (in)	Part No.*
3.10 (0.1220)	33138-73P10
3.19 (0.1256)	33138-73P11
3.28 (0.1291)	33138-73P12

\*: Always check with the Parts Department for the latest parts information.

## SERVICE DATA AND SPECIFICATIONS (SDS)

Available Snap Ring (Cont'd)

### MAIN GEAR BEARING

NGTF0040S0502

Allowable clearance	0 - 0.15 mm (0 - 0.0059 in)
Thickness mm (in)	Part No.*
2.60 (0.1024)	33114-73P00
2.69 (0.1059)	33114-73P01
2.78 (0.1094)	33114-73P02

\*: Always check with the Parts Department for the latest parts information.

### MAINSHAFT REAR BEARING

NGTF0040S0503

Allowable clearance	0 - 0.15 mm (0 - 0.0059 in)
Thickness mm (in)	Part No.*
1.80 (0.0709)	33138-73P20
1.89 (0.0744)	33138-73P21
1.98 (0.0780)	33138-73P22
2.07 (0.0815)	33138-73P23
2.16 (0.0850)	33138-73P24

\*: Always check with the Parts Department for the latest parts information.