

SECTION **PR**
PROPELLER SHAFT

A
B
C

PR

CONTENTS

E

PREPARATION	2	Inspection	8	F
Special Service Tools	2	Disassembly	9	
NOISE, VIBRATION, AND HARSHNESS (NVH)		CENTER BEARING	9	
TROUBLESHOOTING	3	JOURNAL	10	G
NVH Troubleshooting Chart	3	Assembly	11	
ON-VEHICLE SERVICE	4	CENTER BEARING	11	
Propeller Shaft Vibration	4	JOURNAL	11	H
Appearance Checking	4	SERVICE DATA AND SPECIFICATIONS (SDS)	13	
PROPELLER SHAFT ASSEMBLY	5	General Specifications	13	
Components	5	2WD MODEL (KA24DE AND VG33E ENGINES)..	13	
FRONT PROPELLER SHAFT	5	2WD MODEL (VG33ER ENGINE)	13	I
REAR PROPELLER SHAFT	6	4WD MODEL	13	
Removal and Installation	8	Service Data	13	J

K
L
M

PREPARATION

PREPARATION

PFP:00002

Special Service Tools

EDS000ND

The actual shapes of Kent-Moore tools may differ from those of special service tools illustrated here.

Tool number (Kent-Moore No.) Tool name	Description
KV38108300 (J44195) Companion flange wrench	Removing and installing propeller shaft lock nut, and drive pinion lock nut
ST3090S000 (—) Drive pinion rear inner race puller set 1 ST30031000 (J22912-01) Puller 2 ST30901000 (J26010-01) Base	Removing and installing drive pinion rear inner cone a: 79 mm (3.11 in) dia. b: 45 mm (1.77 in) dia. c: 35 mm (1.38 in) dia.
KV40106500 (J-45073) Rear axle shaft bearing puller	Removing wheel bearing, wheel bearing lock nut and ABS sensor rotor

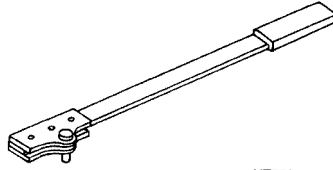

NT771

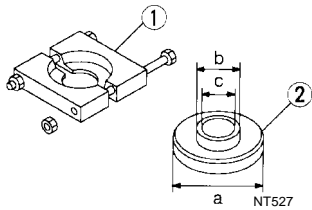

NT527

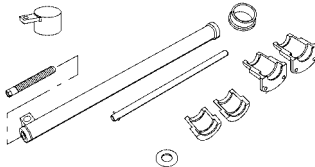

LPD022

ON-VEHICLE SERVICE

Propeller Shaft Vibration

EDS000NG

If vibration is present at high speed, inspect propeller shaft runout first.

1. Raise rear end of vehicle until wheels are clear of the ground.
2. Measure propeller shaft runout at several points along propeller shaft by rotating final drive companion flange with hands.

Runout limit : 0.6 mm (0.024 in)

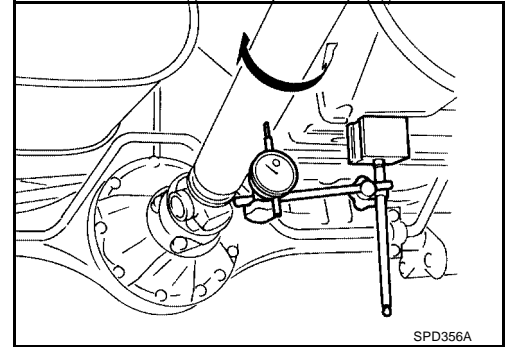

Propeller shaft runout measuring point

Unit: mm (in)

Distance		A	B	C
3S1310 (2WD, KA24DE)	M/T	276 (10.87)	341 (13.43)	—
3S1310 (2WD, VG33E)	A/T	243 (9.57)	338 (13.31)	—
	M/T	290 (11.42)	338 (13.31)	—
3S80B-2BJ (2WD, VG33ER)	A/T	162 (6.38)	240 (9.45)	240 (9.45)
	M/T	162 (6.38)	240 (9.45)	240 (9.45)
2S1310 (4WD, Rear)	All	—	474 (18.66)	—
2F1310 (4WD, Front)	All	271 (10.67)	—	—

3. If runout exceeds specifications, disconnect propeller shaft at final drive companion flange; then rotate companion flange 180 degrees and reconnect propeller shaft.
4. Check runout again. If runout still exceeds specifications, replace propeller shaft assembly.
5. Perform road test.

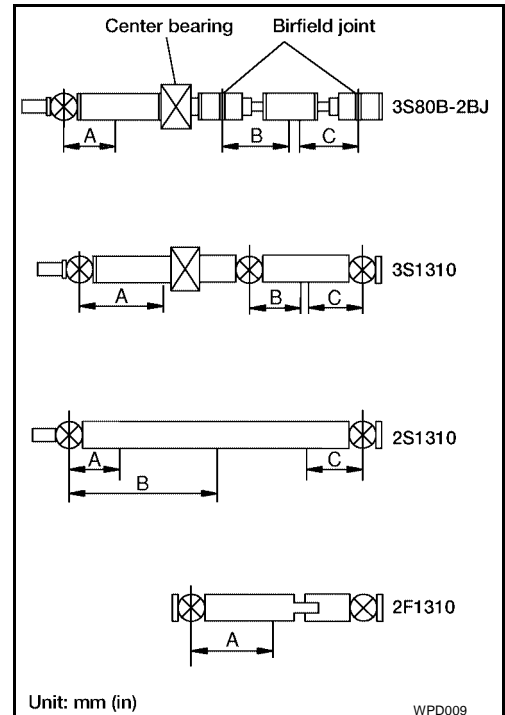

Appearance Checking

EDS000NH

- Inspect propeller shaft tube surface for dents or cracks. If damaged, replace propeller shaft assembly.
- If center bearing is noisy or damaged, replace center bearing.

PROPELLER SHAFT ASSEMBLY

PFP:37000

EDS000NF

PROPELLER SHAFT ASSEMBLY

Components FRONT PROPELLER SHAFT

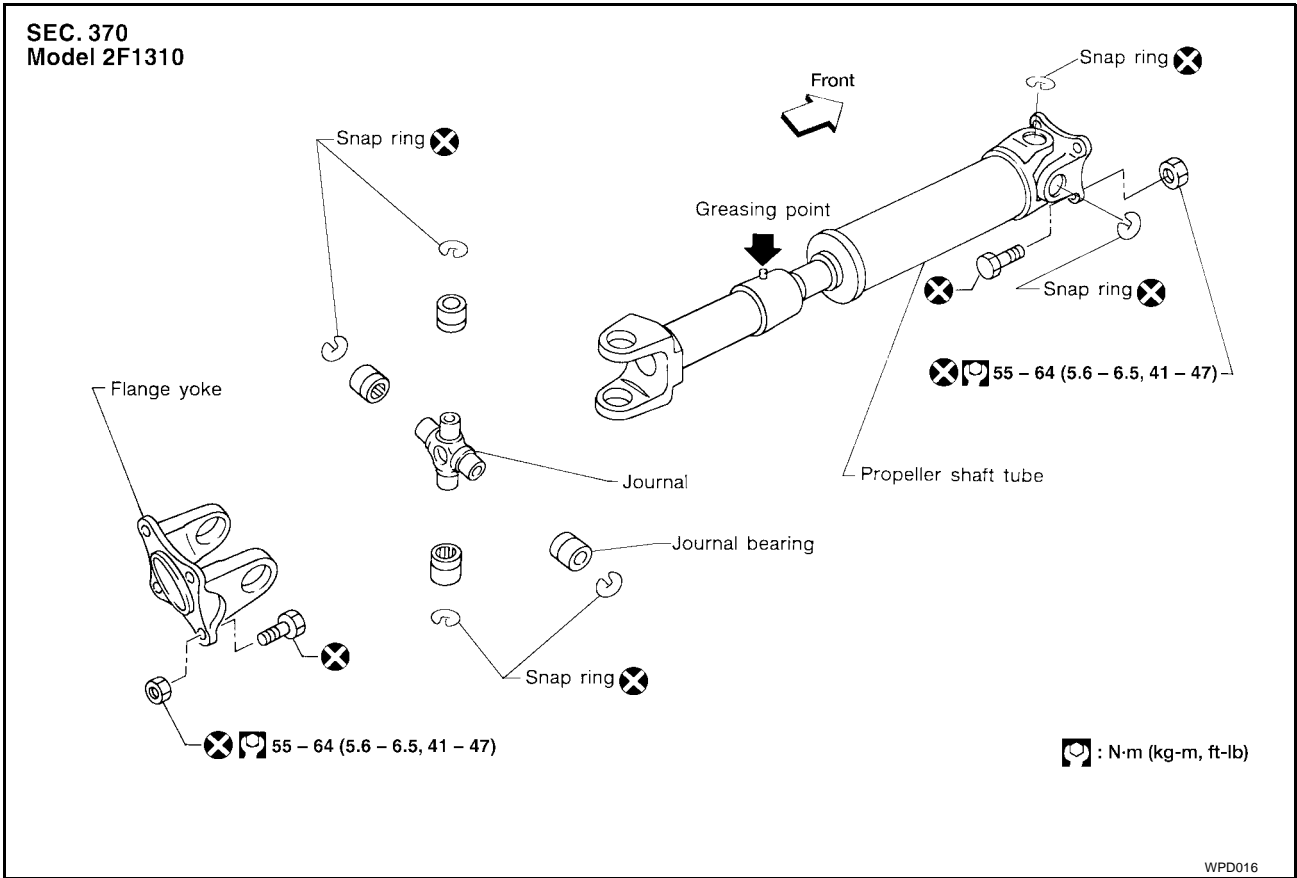

A
B
C
PR
E
F
G
H
I
J
K
L
M

PROPELLER SHAFT ASSEMBLY

REAR PROPELLER SHAFT

SEC 370
4WD
Model 2S1310

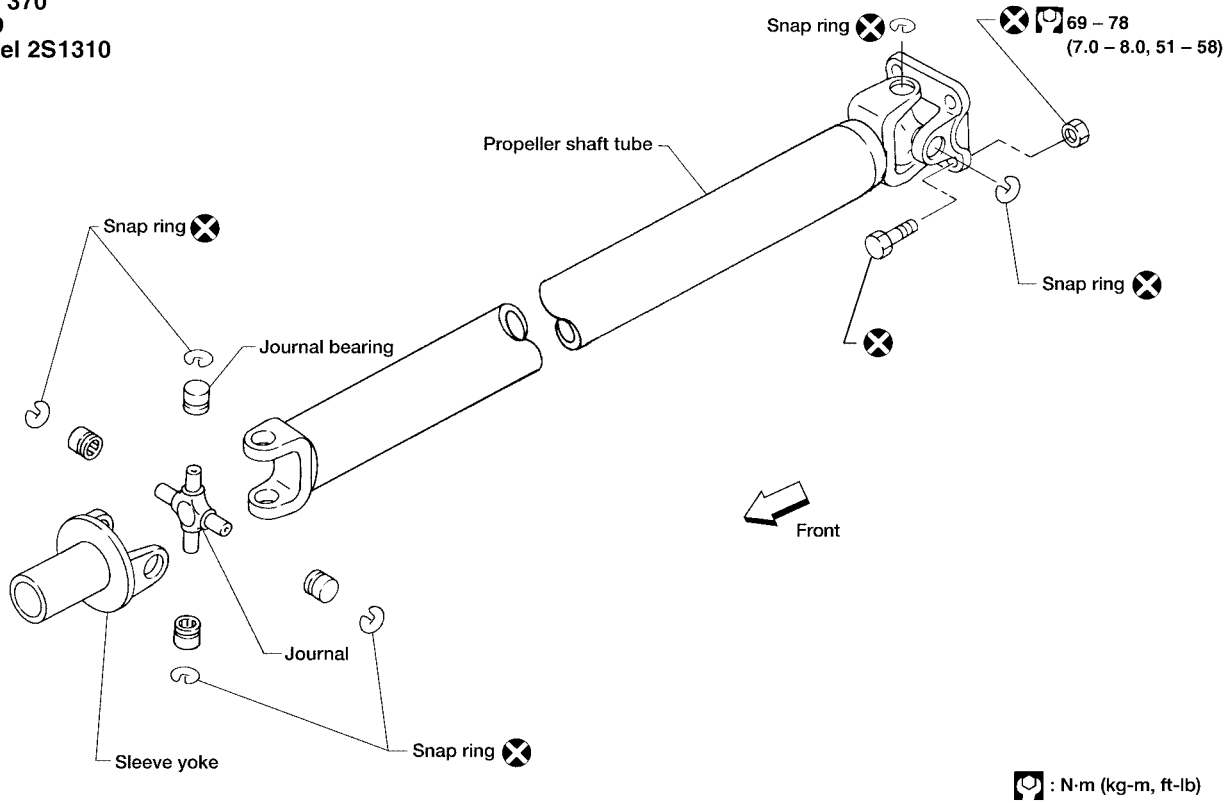

WPD001

SEC. 370
2WD
Model 3S1310

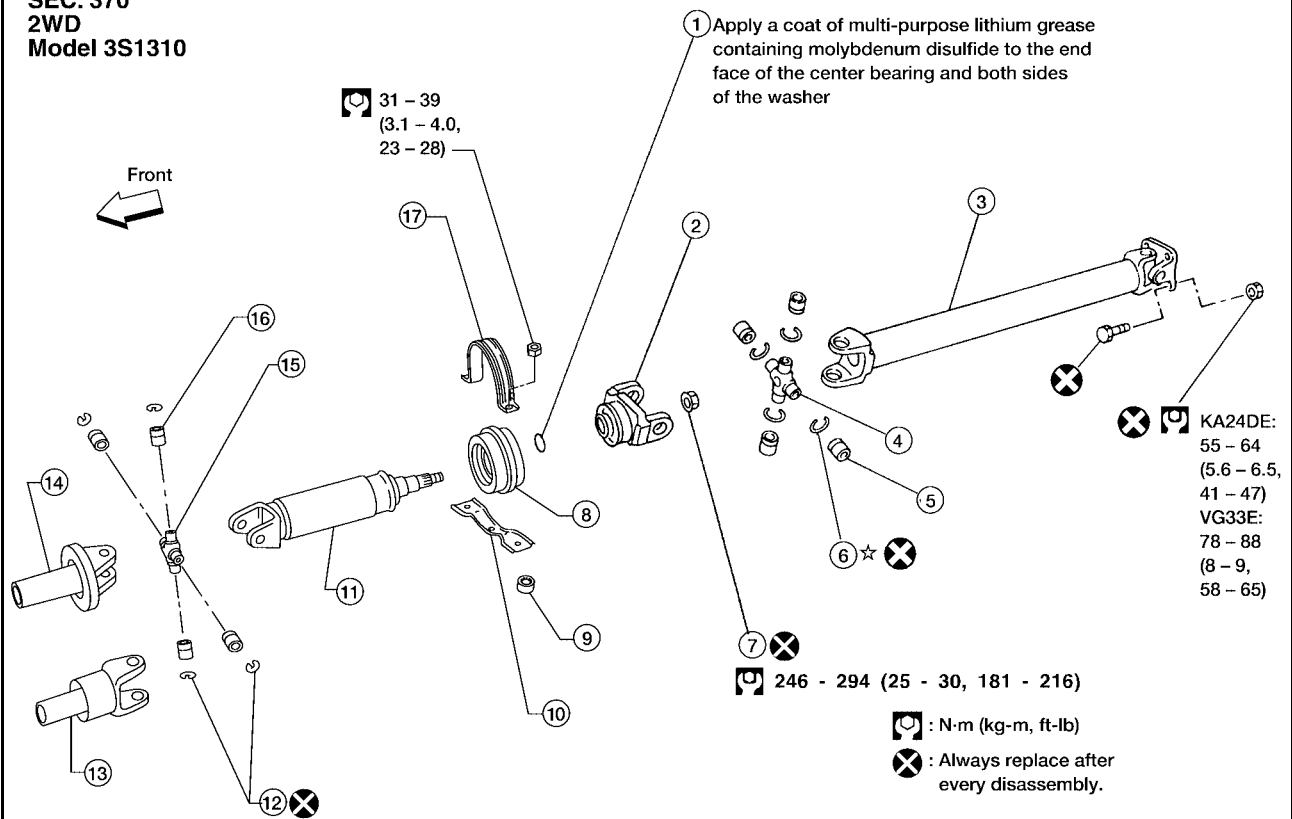

LDIA0025E

PROPELLER SHAFT ASSEMBLY

- | | | |
|---|---|-----------------------------|
| 1. Washer | 2. Flange yoke | 3. Propeller shaft 2nd tube |
| 4. Journal | 5. Journal bearing | 6. Snap ring |
| 7. Lock nut | 8. Center bearing assembly | 9. Spacer |
| 10. Center bearing lower mounting bracket | 11. Propeller shaft 1st tube | 12. Snap ring |
| 13. Sleeve yoke (A/T) | 14. Sleeve yoke (M/T) | 15. Journal |
| 16. Journal bearing | 17. Center bearing upper mounting bracket | |

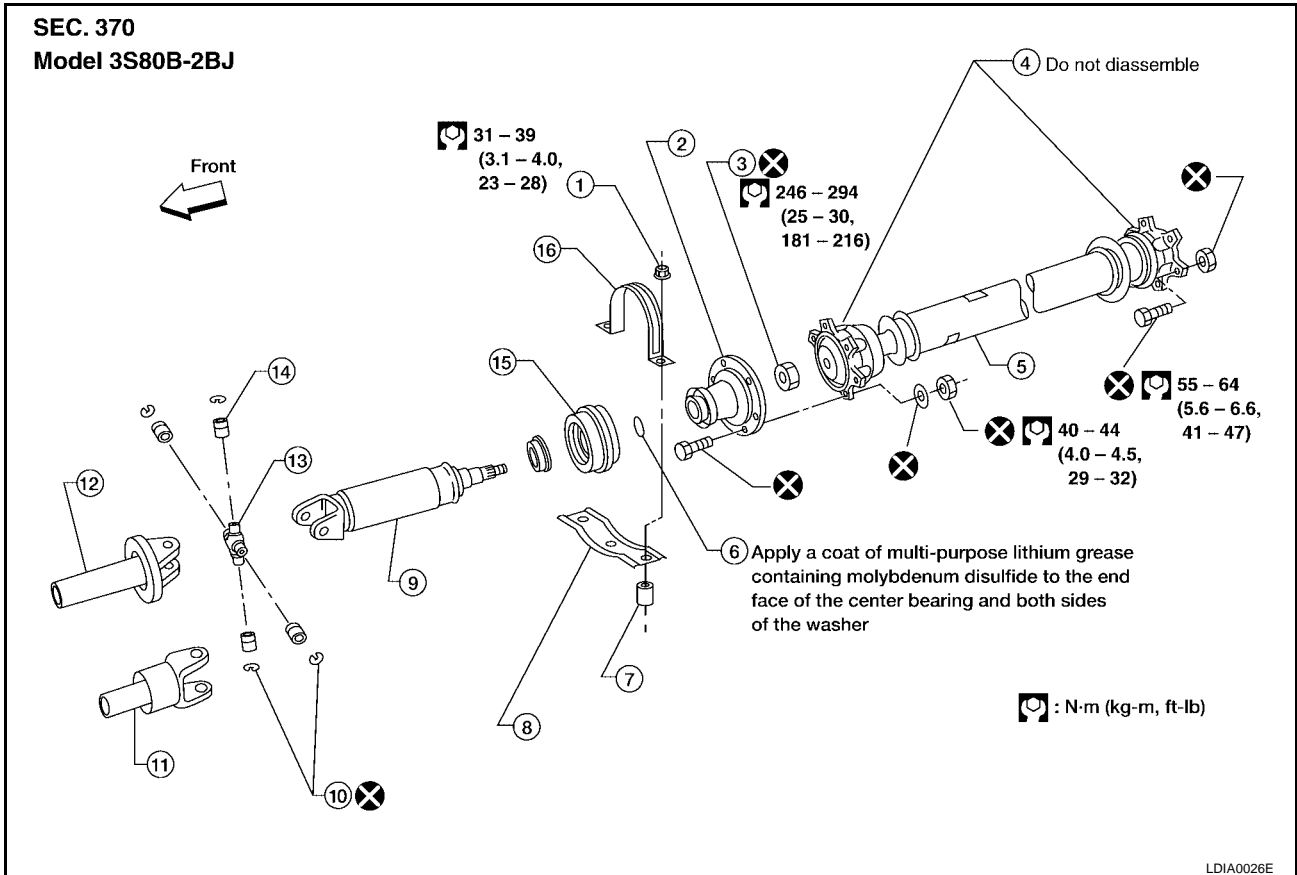

- | | | |
|---|--|-----------------------------|
| 1. Lock nut | 2. Companion flange | 3. Lock nut |
| 4. Birfield joint | 5. Propeller shaft 2nd tube | 6. Washer |
| 7. Spacer | 8. Center bearing lower mounting bracket | 9. Propeller shaft 1st tube |
| 10. Snap ring | 11. Sleeve yoke (A/T) | 12. Sleeve yoke (M/T) |
| 13. Journal | 14. Journal bearing | 15. Center bearing assembly |
| 16. Center bearing upper mounting bracket | | |

PROPELLER SHAFT ASSEMBLY

Removal and Installation

EDS000NI

1. Put match marks on flanges and separate propeller shaft from final drive.

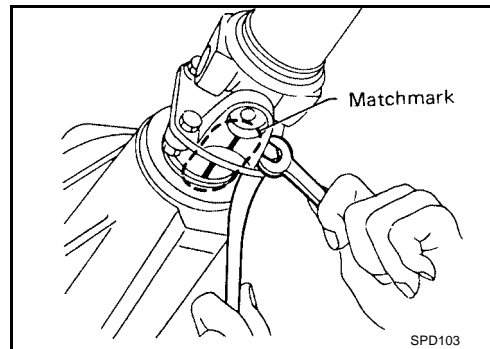

2. Remove propeller shaft.
Insert plug into rear oil seal after removing rear propeller shaft.

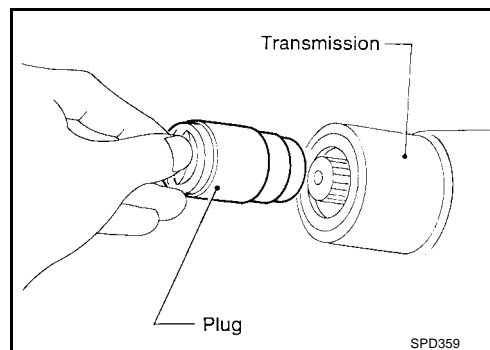

Inspection

EDS000NJ

- Inspect propeller shaft runout. If runout exceeds specifications, replace propeller shaft assembly.

Runout limit : 0.6 mm (0.024 in)

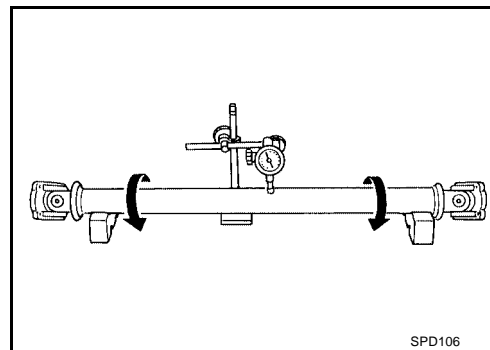

- If the play exceeds specifications, replace propeller shaft assembly.

Journal axial play : 0.02 mm (0.0008 in) or less

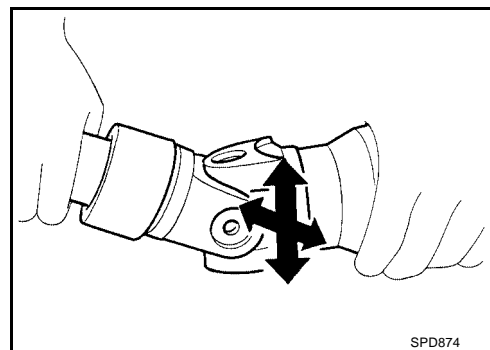

PROPELLER SHAFT ASSEMBLY

EDS000NK

Disassembly CENTER BEARING

1. Put match marks on flanges, and separate 2nd tube from 1st tube.

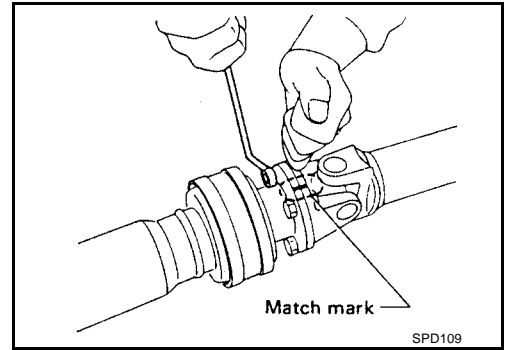

2. Put match marks on the flange and shaft.

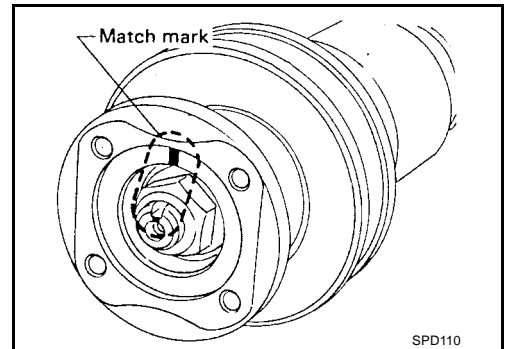

3. Remove locking nut with Tool.

Tool number : KV38108300 (J44195)

4. Remove companion flange with puller.

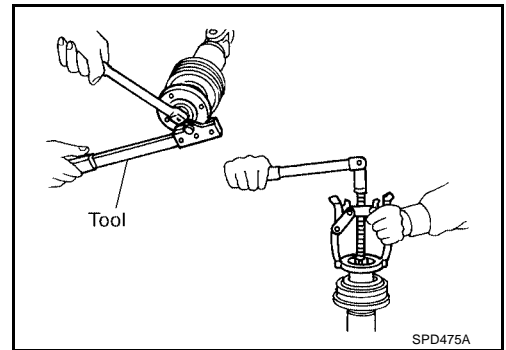

5. Remove center bearing with Tool and press.

Tool number : ST30031000 (J22912-01)

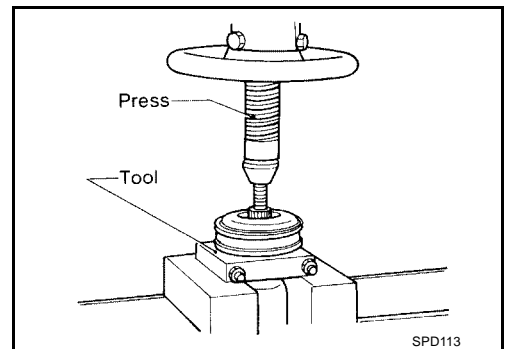

A
B
C
PR
E
F
G
H
I
J
K
L
M

PROPELLER SHAFT ASSEMBLY

JOURNAL

1. Put match marks on shaft and flange or yoke.

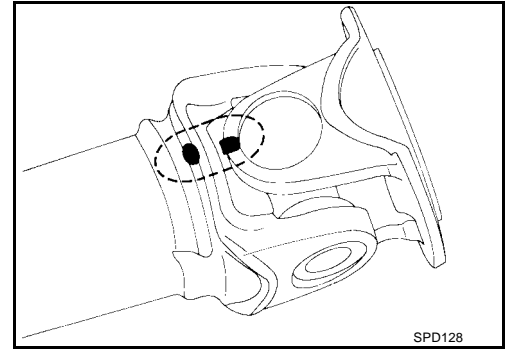

2. Remove snap ring.

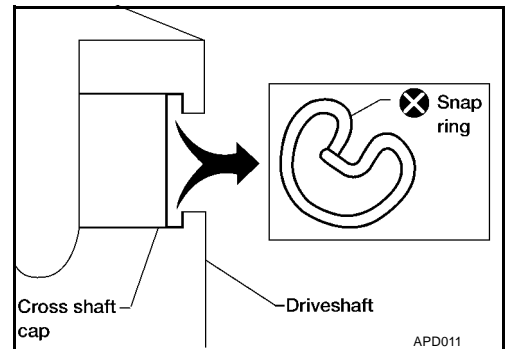

3. Remove pushed out journal bearing by lightly tapping yoke with a hammer, taking care not to damage journal and yoke hole.

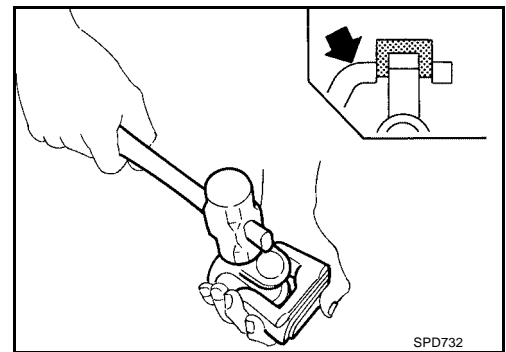

4. Remove bearing at opposite side in above operation.
Put marks on disassembled parts so that they can be reinstalled in their original positions from which they were removed.

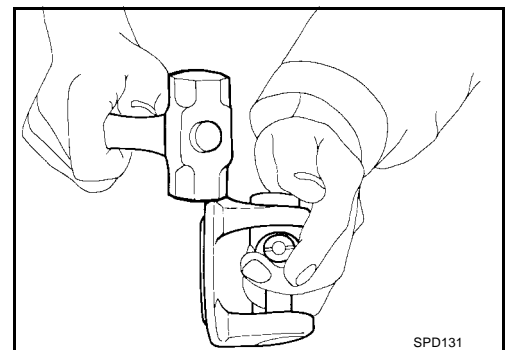

PROPELLER SHAFT ASSEMBLY

EDS000NL

Assembly CENTER BEARING

1. When installing center bearing, position the "F" mark on center bearing toward front of vehicle.
Apply a coat of multi-purpose lithium grease containing molybdenum disulfide to the end face of the center bearing and both sides of the washer.

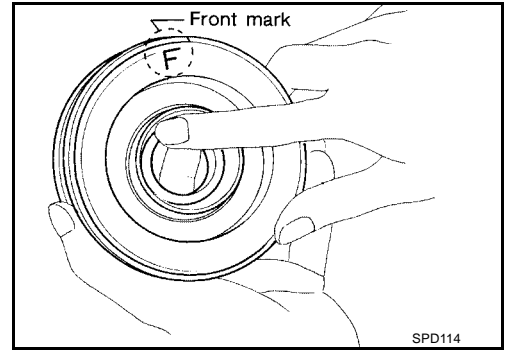

2. Stake the nut. Always use new one.
3. Align match marks when assembling tubes.

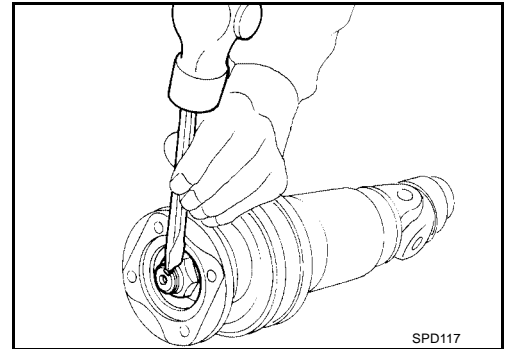

JOURNAL

1. Assemble journal bearing. Apply recommended multi-purpose grease on bearing inner surface.
When assembling, be careful that needle bearing does not fall down.

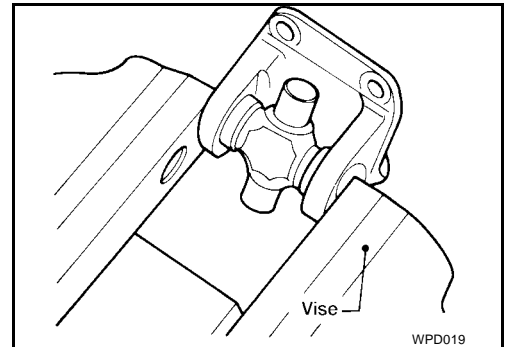

2. Install new snap rings.

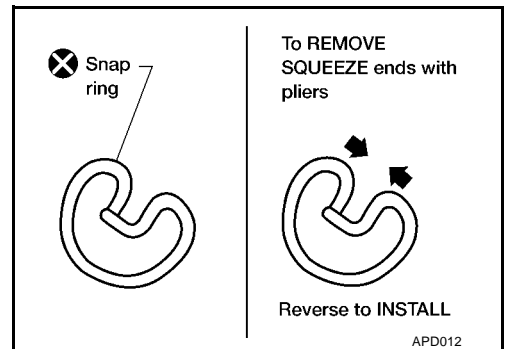

A
B
C
PR
E
F
G
H
I
J
K
L
M

PROPELLER SHAFT ASSEMBLY

3. Adjust thrust clearance between bearing and snap ring to zero by tapping yoke.

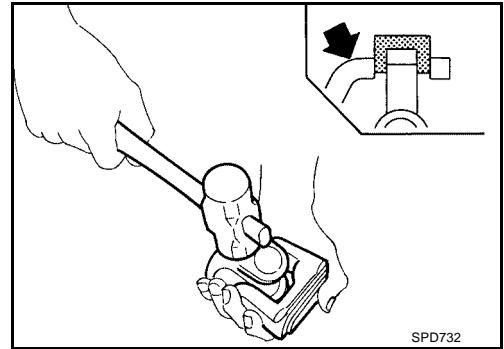

4. Check to see that journal moves smoothly and check for axial play.

Axial play : 0.02 mm (0.0008 in) or less

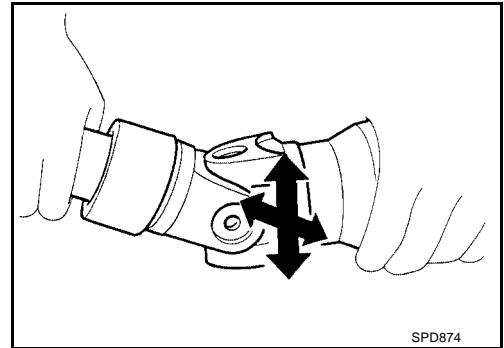

SERVICE DATA AND SPECIFICATIONS (SDS)

SERVICE DATA AND SPECIFICATIONS (SDS)

PF0:00030

General Specifications 2WD MODEL (KA24DE AND VG33E ENGINES)

EDS000NM

Engine		KA24DE	VG33E	
Transmission		M/T	M/T	A/T
Propeller shaft model		3S1310		
Number of joints		3		
Coupling method with transmission		Sleeve type		
Type of journal bearings		Solid type (disassembly type)		
Distance between yokes mm (in)		71 (2.80)	80 (3.15)	
Shaft length (Spider to spider) mm (in)	1st	640 (25.20)	665 (26.18)	570 (22.44)
	2nd	687 (27.05)	684 (26.93)	
Shaft outer diameter mm (in)	1st	63.5 (2.50)		
	2nd	63.5 (2.50)		

2WD MODEL (VG33ER ENGINE)

Transmission		M/T	A/T
Propeller shaft model		3S80B-2BJ	
Number of joints		3	
Coupling method with transmission		Sleeve type	
Type of journal bearings		Solid type (disassembly type)	
Distance between yokes mm (in)		80 (3.15)	
Shaft length (Spider to spider) mm (in)	1st	681 (26.81)	586 (23.07)
	2nd	685 (26.97)	
Shaft outer diameter mm (in)	1st	75 (2.95)	
	2nd	65 (2.56)	

4WD MODEL

Location	Front	Rear
Propeller shaft model	2F1310	2S1310
Number of joints	2	2
Coupling method with transmission	Flange type	Sleeve type
Type of journal bearings	Solid type (disassembly type)	
Distance between yokes mm (in)	71 (2.80)	80 (3.15)
Shaft length (Spider to spider) mm (in)	522 (20.60)	954.3 (37.57)
Shaft outer diameter mm (in)	50.8 (2.0)	76.2 (3.0)

Service Data

EDS000NM

Unit: mm (in)

Propeller shaft runout limit	0.6 (0.024)
Journal axial play	0.02 (0.0008) or less

SERVICE DATA AND SPECIFICATIONS (SDS)
