

SECTION **HAC**

**HEATER & AIR CONDITIONING CONTROL SYSTEM**

**CONTENTS**

<b>MANUAL AIR CONDITIONER</b>	
<b>BASIC INSPECTION</b> .....	<b>3</b>
<b>DIAGNOSIS AND REPAIR WORKFLOW</b> .....	<b>3</b>
How to Perform Trouble Diagnosis For Quick And Accurate Repair .....	3
<b>INSPECTION AND ADJUSTMENT</b> .....	<b>4</b>
Operational Check .....	4
<b>FUNCTION DIAGNOSIS</b> .....	<b>6</b>
<b>FUNCTION INFORMATION</b> .....	<b>6</b>
Component Part Location .....	6
Symptom Table .....	8
<b>REFRIGERATION SYSTEM</b> .....	<b>9</b>
Refrigerant Cycle .....	9
Refrigerant System Protection .....	9
<b>MANUAL AIR CONDITIONER SYSTEM</b> .....	<b>10</b>
Control System Diagram .....	10
Control System Description .....	10
Discharge Air Flow .....	11
Switches And Their Control Function .....	12
<b>CAN COMMUNICATION SYSTEM</b> .....	<b>14</b>
System Description .....	14
<b>DIAGNOSIS SYSTEM (BCM)</b> .....	<b>15</b>
CONSULT-III Function (BCM) .....	15
<b>COMPONENT DIAGNOSIS</b> .....	<b>16</b>
<b>MODE DOOR MOTOR</b> .....	<b>16</b>
System Description .....	16
Mode Door Motor Component Function Check .....	16
Mode Door Motor Diagnosis Procedure .....	17
<b>AIR MIX DOOR MOTOR</b> .....	<b>20</b>
System Description .....	20
Air Mix Door Motor Component Function Check .....	21
Air Mix Door Motor Diagnosis Procedure .....	22
<b>INTAKE DOOR MOTOR</b> .....	<b>24</b>
System Description .....	24
Intake Door Motor Component Function Check .....	24
Intake Door Motor Diagnosis Procedure .....	25
<b>BLOWER MOTOR</b> .....	<b>27</b>
System Description .....	27
Front Blower Motor Component Function Check .....	27
Front Blower Motor Diagnosis Procedure .....	28
Front Blower Motor Component Inspection .....	32
<b>MAGNET CLUTCH</b> .....	<b>34</b>
System Description .....	34
Magnet Clutch Component Function Check .....	34
Magnet Clutch Diagnosis Procedure .....	34
<b>INTAKE SENSOR</b> .....	<b>39</b>
System Description .....	39
Intake Sensor Diagnosis Procedure .....	39
Intake Sensor Component Inspection .....	40
<b>POWER SUPPLY AND GROUND CIRCUIT FOR CONTROLLER</b> .....	<b>41</b>
Component Description .....	41
Front Air Control Component Function Check .....	41
Front Air Control Power and Ground Diagnosis Procedure .....	42
<b>ECU DIAGNOSIS</b> .....	<b>43</b>
<b>AIR CONDITIONER CONTROL</b> .....	<b>43</b>
Front Air Control Terminals Reference Values .....	43
Wiring Diagram .....	45
<b>SYMPTOM DIAGNOSIS</b> .....	<b>52</b>
<b>AIR CONDITIONER CONTROL</b> .....	<b>52</b>
Symptom Matrix Chart .....	52
<b>INSUFFICIENT COOLING</b> .....	<b>53</b>
Component Function Check .....	53

A  
B  
C  
D  
E  
F  
G  
H  
HAC  
J  
K  
L  
M  
N  
O  
P

---

Diagnostic Work Flow .....	54	<b>PRECAUTION</b> .....	<b>65</b>
Performance Chart .....	56	<b>PRECAUTIONS</b> .....	<b>65</b>
Trouble Diagnoses for Abnormal Pressure .....	57	Precaution for Supplemental Restraint System (SRS) "AIR BAG" and "SEAT BELT PRE-TEN- SIONER" .....	65
<b>INSUFFICIENT HEATING</b> .....	<b>61</b>	Working with HFC-134a (R-134a) .....	65
Component Function Check .....	61	Precaution for Service Equipment .....	66
<b>NOISE</b> .....	<b>63</b>		
Component Function Check .....	63		

## BASIC INSPECTION

### DIAGNOSIS AND REPAIR WORKFLOW

How to Perform Trouble Diagnosis For Quick And Accurate Repair

INFOID:000000003081761

#### WORK FLOW

#### 1. LISTEN TO CUSTOMER COMPLAINT

Listen to customer complaint. Get detailed information about the conditions and environment when the symptom occurs.

>> GO TO 2

#### 2. CHECK FOR SERVICE BULLETINS

Check for any service bulletins.

>> GO TO 3.

#### 3. VERIFY THE SYMPTOM WITH OPERATIONAL CHECK

Verify the symptom with operational check. Refer to [HAC-4, "Operational Check"](#).

Can a symptom be duplicated?

- YES >> Go to trouble diagnosis. Refer to [HAC-52, "Symptom Matrix Chart"](#)
- NO >> System OK.

A  
B  
C  
D  
E  
F  
G  
H  
J  
K  
L  
M  
N  
O  
P

HAC

## INSPECTION AND ADJUSTMENT

## Operational Check

INFOID:000000003081762

The purpose of the operational check is to confirm that the system operates properly.

**Conditions : Engine running and at normal operating temperature**

## CHECKING BLOWER

1. Turn blower control dial clockwise. Blower should operate on low speed.
2. Turn the blower control dial again, and continue checking each blower speed until all speeds are checked.
3. Leave blower on speed 4.

If NG, go to trouble diagnosis procedure for [HAC-28. "Front Blower Motor Diagnosis Procedure"](#).

If OK, continue with next check.

## CHECKING DISCHARGE AIR



1. Turn the mode switch to each position.
2. Confirm that discharge air comes out according to the air distribution table. Refer to [HAC-11. "Discharge Air Flow"](#).

Mode door position is checked in the next step.



If NG, go to trouble diagnosis procedure for [HAC-17. "Mode Door Motor Diagnosis Procedure"](#).

If OK, continue with next check.

**NOTE:**

Confirm that the A/C compressor clutch is engaged (sound or visual inspection) and intake door position is at fresh when the DEF (  ) or D/F (  ) is selected.

## CHECKING RECIRCULATION

1. Press recirculation (  ) switch one time. Recirculation indicator should illuminate.
2. Press recirculation (  ) switch one more time. Recirculation indicator should go off.
3. Listen for intake door position change (blower sound should change slightly).

If NG, go to trouble diagnosis procedure for [HAC-25. "Intake Door Motor Diagnosis Procedure"](#).

If OK, continue with next check.

**NOTE:**

Confirm that the compressor clutch is engaged (sound or visual inspection) and intake door position is at fresh when the DEF or D/F is selected.

## CHECKING TEMPERATURE DECREASE

1. Rotate temperature control dial counterclockwise.
2. Check for cold air at appropriate discharge air outlets.

If NG, listen for sound of air mix door motor operation. If OK, go to trouble diagnosis procedure for [HAC-53. "Component Function Check"](#). If air mix door motor appears to be malfunctioning, go to [HAC-21. "Air Mix Door Motor Component Function Check"](#).

If OK, continue with next check.

## CHECKING TEMPERATURE INCREASE

1. Rotate temperature control dial clockwise.
2. Check for hot air at appropriate discharge air outlets.

If NG, listen for sound of air mix door motor operation. If OK, go to trouble diagnosis procedure for [HAC-61. "Component Function Check"](#). If air mix door motor (front) appears to be malfunctioning, go to [HAC-21. "Air Mix Door Motor Component Function Check"](#).

If OK, continue with next check.

## CHECK A/C SWITCH

1. Press A/C switch with the blower switch ON.
2. A/C switch indicator will turn ON.
  - Confirm that the compressor clutch engages (sound or visual inspection).

# INSPECTION AND ADJUSTMENT

< BASIC INSPECTION >

[MANUAL AIR CONDITIONER]

If NG, go to trouble diagnosis procedure for [HAC-34. "Magnet Clutch Diagnosis Procedure"](#).  
If OK, continue with next check.

A

B

C

D

E

F

G

H

**HAC**

J

K

L

M

N

O

P

FUNCTION DIAGNOSIS

FUNCTION INFORMATION

Component Part Location

INFOID:000000003081763

ENGINE COMPARTMENT

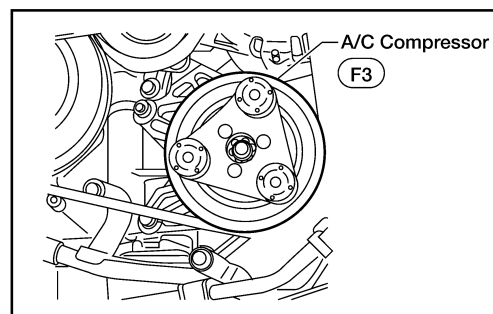
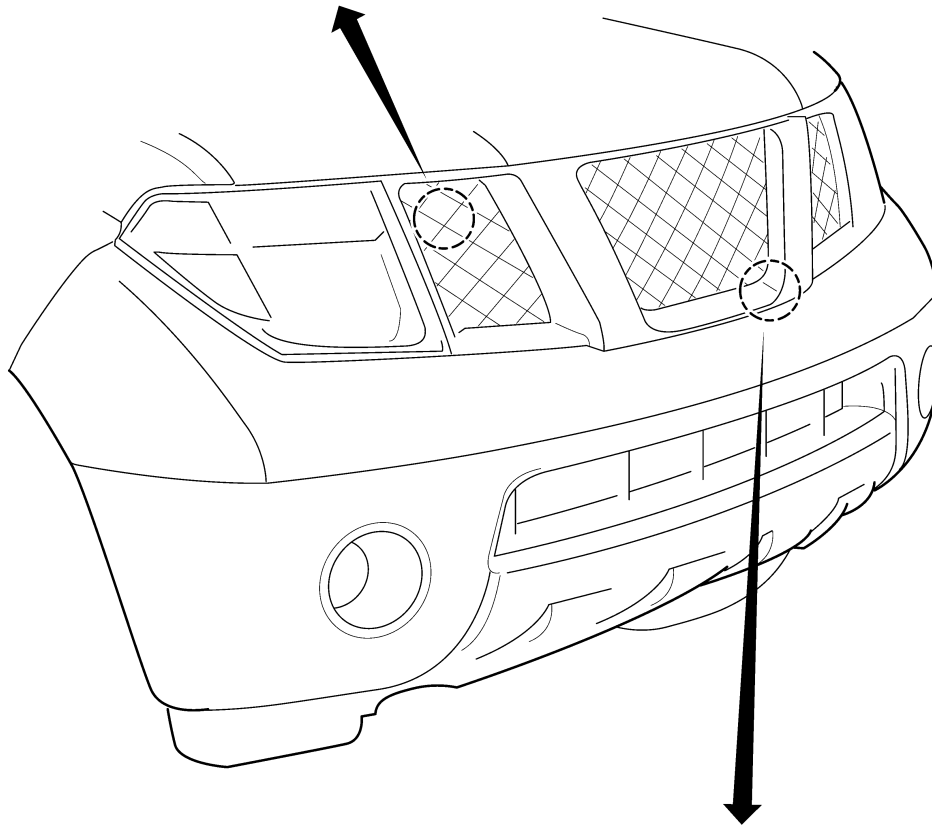
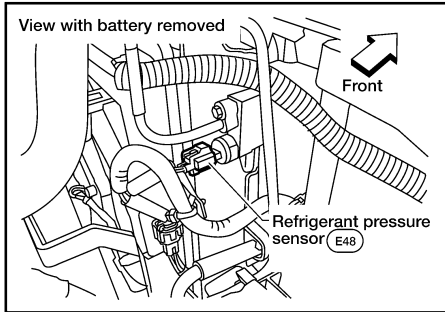

WJIA1489E

# FUNCTION INFORMATION

< FUNCTION DIAGNOSIS >

[MANUAL AIR CONDITIONER]

## PASSENGER COMPARTMENT

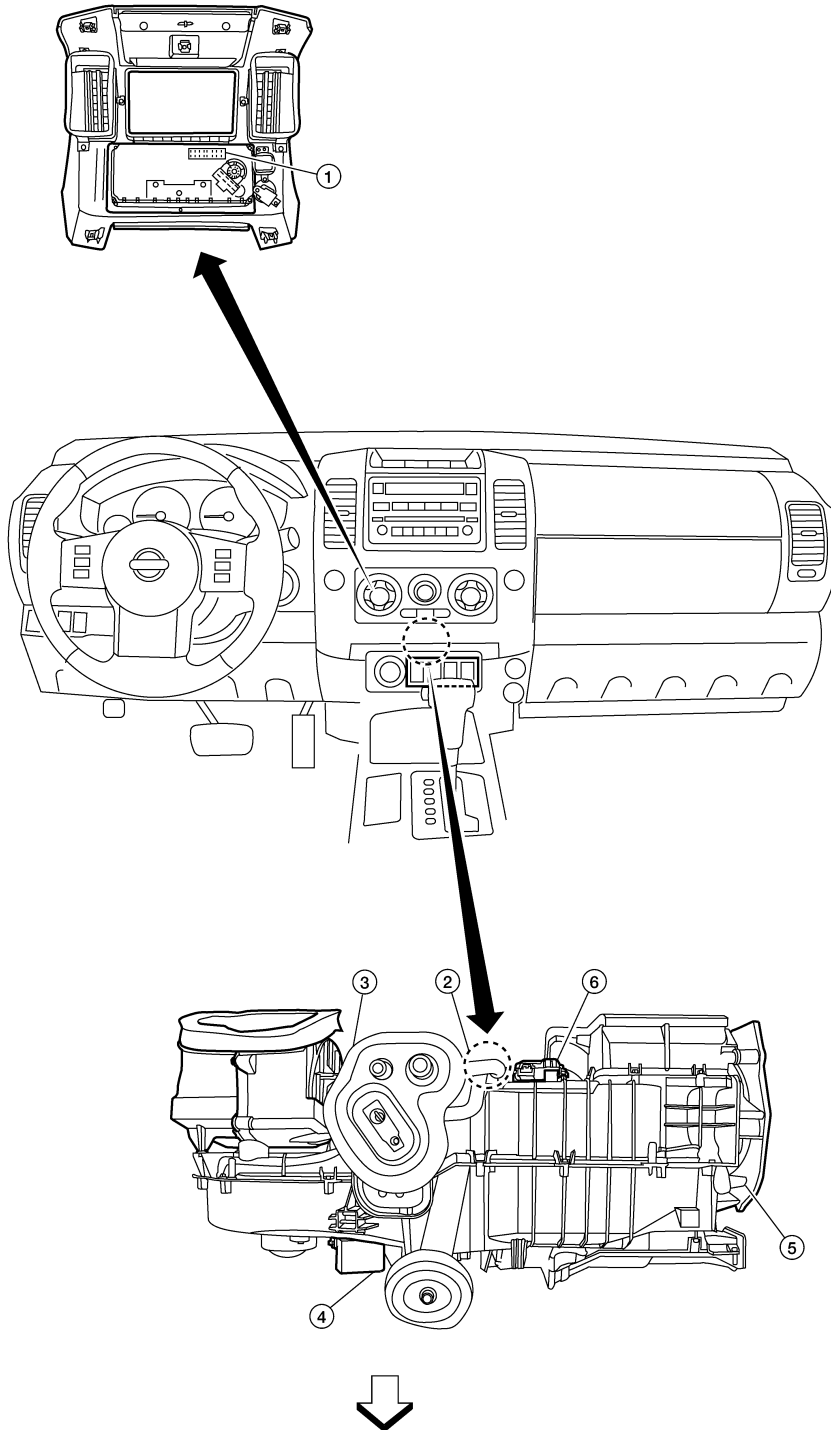

A  
B  
C  
D  
E  
F  
G  
H  
HAC  
J  
K  
L  
M  
N  
O  
P

⇒ :Front

1. Front air control M49

2. Intake sensor M146

AWIIA0724ZZ

# FUNCTION INFORMATION

[MANUAL AIR CONDITIONER]

## < FUNCTION DIAGNOSIS >

- 3. Intake door motor M58
- 4. Front blower motor resistor M122
- 5. Mode door motor M142
- 6. Air mix door motor M147

## Symptom Table

INFOID:000000003081764

Symptom	Reference Page
A/C system does not come on.	Go to Trouble Diagnosis Procedure for A/C System. <a href="#">HAC-41</a>
Air outlet does not change.	Go to Trouble Diagnosis Procedure for Mode Door Motor. <a href="#">HAC-16</a>
Mode door motor is malfunctioning.	
Discharge air temperature does not change.	Go to Trouble Diagnosis Procedure for Air Mix Door Motor. <a href="#">HAC-21</a>
Air mix door motor is malfunctioning.	
Intake door does not change.	Go to Trouble Diagnosis Procedure for Intake Door Motor. <a href="#">HAC-24</a>
Intake door motor is malfunctioning.	
Front blower motor operation is malfunctioning.	Go to Trouble Diagnosis Procedure for Front Blower Motor. <a href="#">HAC-27</a>
Magnet clutch does not engage.	Go to Trouble Diagnosis Procedure for Magnet Clutch. <a href="#">HAC-34</a>
Insufficient cooling	Go to Trouble Diagnosis Procedure for Insufficient Cooling. <a href="#">HAC-53</a>
Insufficient heating	Go to Trouble Diagnosis Procedure for Insufficient Heating. <a href="#">HAC-61</a>
Noise	Go to Trouble Diagnosis Procedure for Noise. <a href="#">HAC-63</a>



## REFRIGERATION SYSTEM

Refrigerant Cycle

INFOID:000000003081765

Refer to [HA-16. "Refrigerant Cycle"](#).

Refrigerant System Protection

INFOID:000000003081766

Refer to [HA-16. "Refrigerant System Protection"](#).

A

B

C

D

E

F

G

H

**HAC**

J

K

L

M

N

O

P

# MANUAL AIR CONDITIONER SYSTEM

< FUNCTION DIAGNOSIS >

[MANUAL AIR CONDITIONER]

## MANUAL AIR CONDITIONER SYSTEM

### Control System Diagram

INFOID:000000003081767

#### CONTROL SYSTEM

The control system consists of input sensors, switches, the front air control (microcomputer) and outputs. The relationship of these components is shown in the figure below:

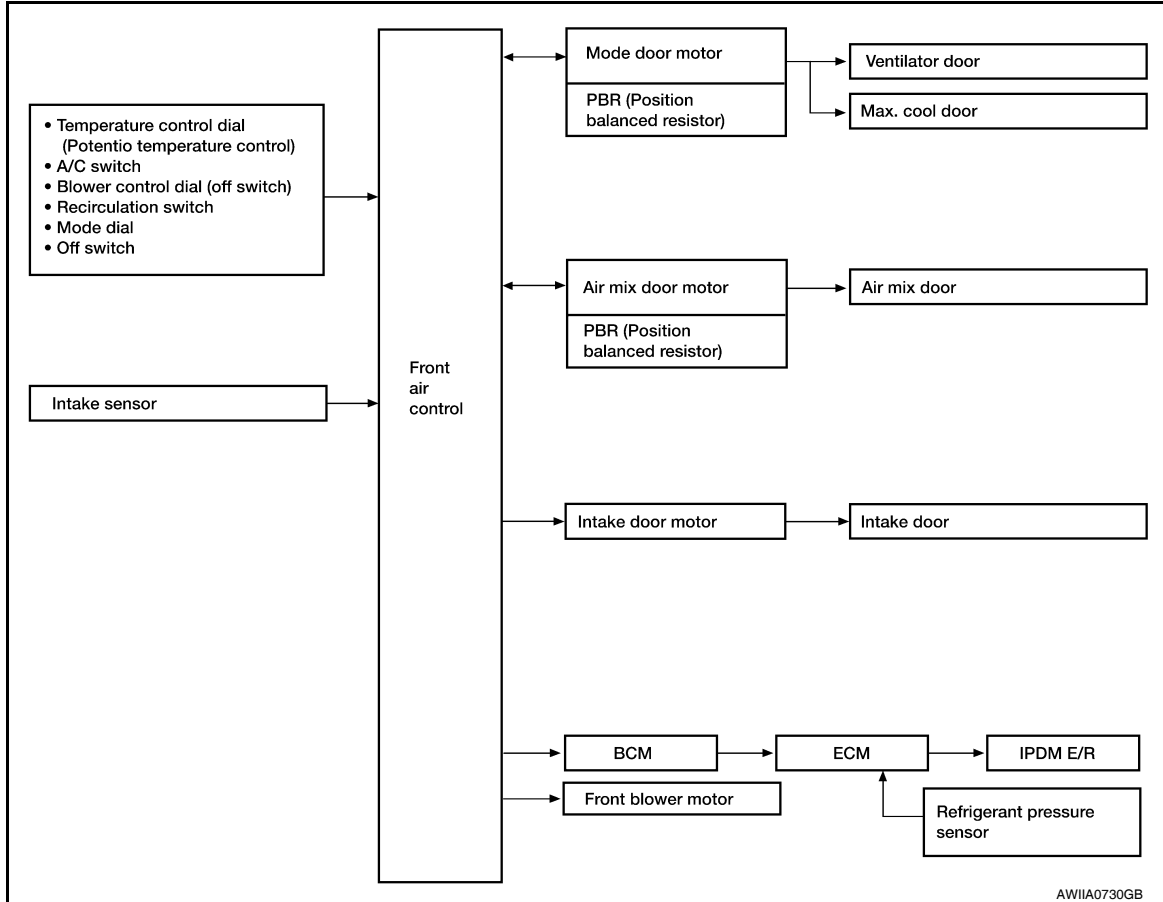

AWIIA0730GB

### Control System Description

INFOID:000000003081768

#### CONTROL OPERATION

##### Front air control

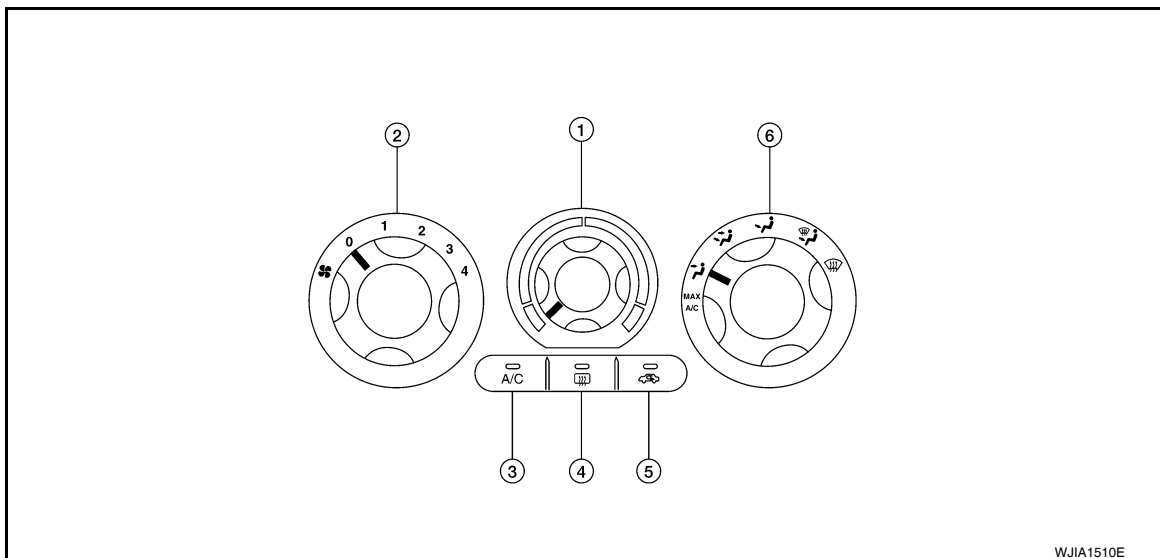

WJIA1510E

# MANUAL AIR CONDITIONER SYSTEM

< FUNCTION DIAGNOSIS >

[MANUAL AIR CONDITIONER]

- |                                |                         |               |
|--------------------------------|-------------------------|---------------|
| 1. Temperature control dial    | 2. Blower control dial  | 3. A/C switch |
| 4. Rear window defogger switch | 5. Recirculation switch | 6. Mode dial  |

## TEMPERATURE CONTROL DIAL (TEMPERATURE CONTROL)

Increases or decreases the set temperature.

## RECIRCULATION ( ) SWITCH

- When REC switch is ON, REC switch indicator turns ON, and air inlet is set to REC.
- When REC switch is turned OFF, or when compressor is turned from ON to OFF, REC switch is automatically turned OFF. REC mode can be re-entered by pressing REC switch again.
- REC switch is not operated when DEF switch is turned ON, or at the D/F or FOOT position.

## REAR WINDOW DEFOGGER SWITCH

When switch is ON, rear window is defogged.

## OFF SWITCH (BLOWER SPEED SET TO 0)

The compressor and blower are OFF.

## A/C SWITCH

The compressor is ON or OFF.

(Pressing the A/C switch will turn off the A/C switch and compressor.)

## MODE DIAL

Controls the air discharge outlets.

## FRONT BLOWER CONTROL DIAL

Manually controls the four blower speeds.

## MAGNET CLUTCH CONTROL

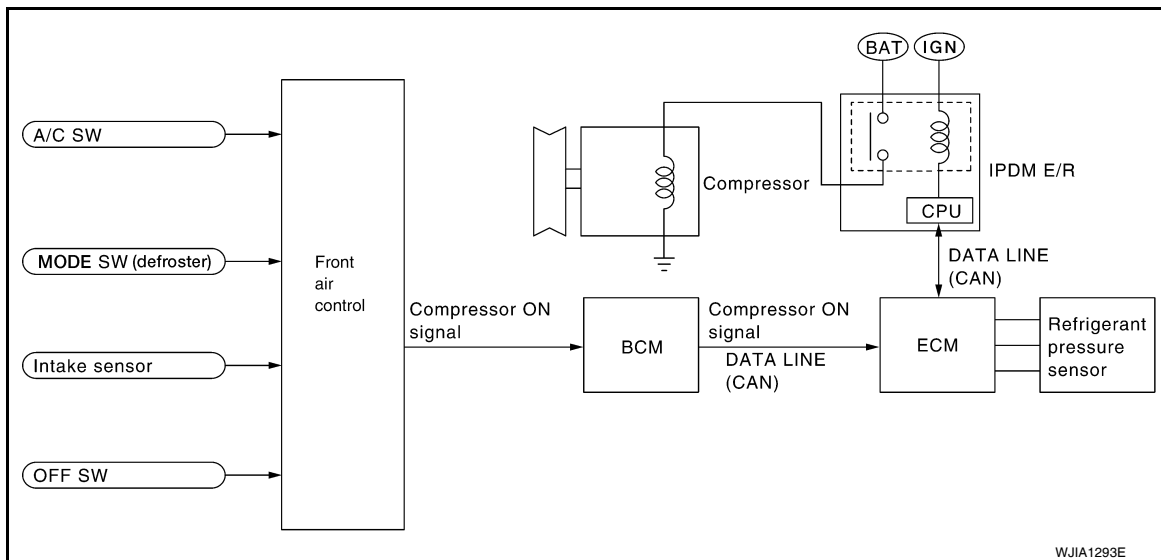

When the A/C switch is pressed, or the mode dial is turned to the DEF or D/F position, the front air control outputs a compressor ON signal to BCM.

The BCM then sends a compressor ON signal to ECM, via CAN communication line.

ECM judges whether compressor can be turned ON, based on each sensor status (refrigerant pressure sensor signal, throttle angle sensor, etc.). If it judges compressor can be turned ON, it sends compressor ON signal to IPDM E/R, via CAN communication line.

Upon receipt of compressor ON signal from ECM, IPDM E/R turns air conditioner relay ON to operate compressor.

## Discharge Air Flow

INFOID:000000003081769

# MANUAL AIR CONDITIONER SYSTEM

< FUNCTION DIAGNOSIS >

[MANUAL AIR CONDITIONER]

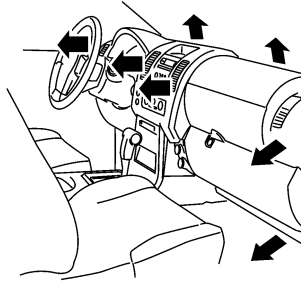

WJIA1296E

Mode door position	Air outlet/distribution		
	Vent	Foot	Defroster
	95%	5%	—
	60%	40%	—
	20%	55%	25%
	15%	50%	35%
	7%	15%	78%

Airflow always present at driver and passenger side demisters

## Switches And Their Control Function

INFOID:000000003081770

### SWITCHES AND THEIR CONTROL FUNCTION

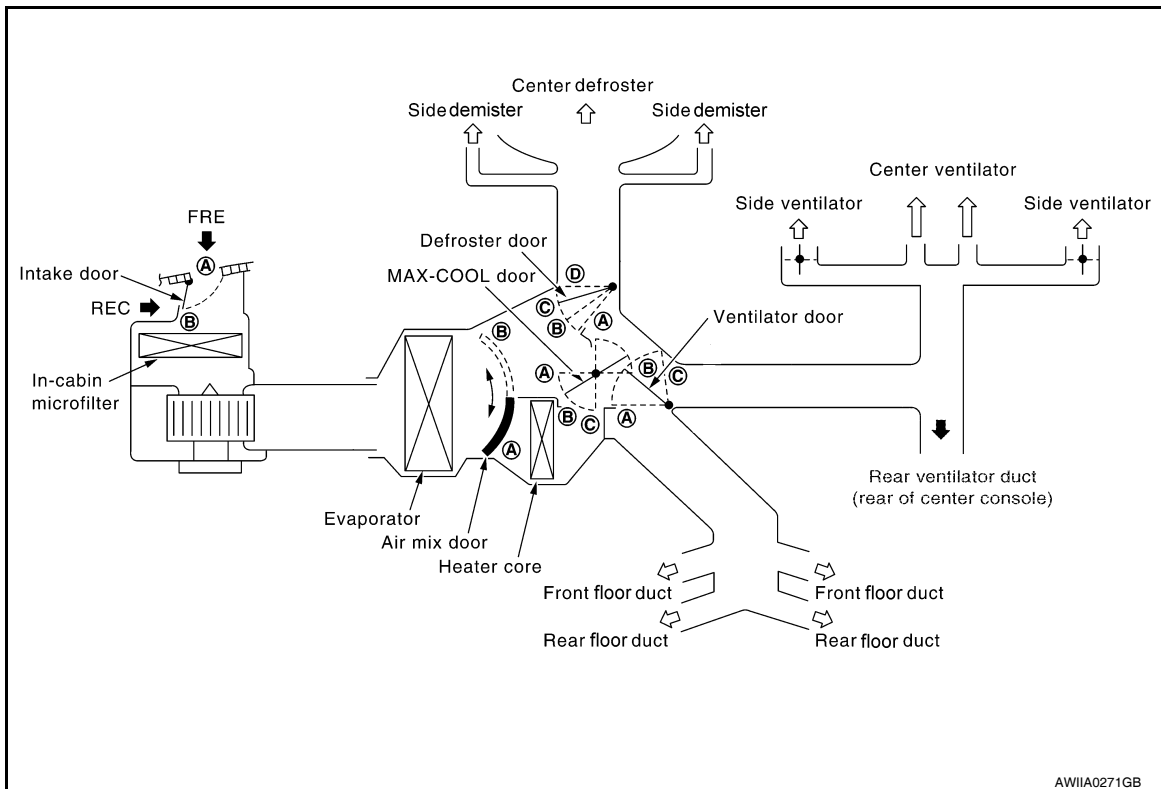

AWIIA0271GB

# MANUAL AIR CONDITIONER SYSTEM

< FUNCTION DIAGNOSIS >

[MANUAL AIR CONDITIONER]

Door Position or switch	MODE SW				DEF SW		REC SW		Temperature dial			OFF SW
	VENT	B/L	FOOT	D/F	ON	OFF	ON	OFF				
									COLD	~	HOT	OFF
Ventilator door	(A)	(B)	(C)	(C)	(C)	—	—	—	—			(C)
MAX-COOL door	(A)	(B)	(B)	(B)	(C)		—	—	—			(B)
Defroster door	(D)	(D)	(D <sub>or</sub> C)	(B)	(A)		—	—	—			(C)
Intake door	—				(B)		(A)	(B)	—			(B)
Air mix door	—				—		—	(A)		(B)	—	

WJIA1497E

A  
B  
C  
D  
E  
F  
G  
H  
J  
K  
L  
M  
N  
O  
P

HAC

**CAN COMMUNICATION SYSTEM**

**System Description**

INFOID:000000003081771

Refer to [LAN-4. "System Description"](#).

# DIAGNOSIS SYSTEM (BCM)

< FUNCTION DIAGNOSIS >

[MANUAL AIR CONDITIONER]

## DIAGNOSIS SYSTEM (BCM)

### CONSULT-III Function (BCM)

INFOID:000000003081772

CONSULT-III can display each diagnostic item using the diagnostic test modes shown following.

Diagnosis mode	Function Description
WORK SUPPORT	Changes the setting for each system function.
SELF-DIAG RESULTS	Displays the diagnosis results judged by BCM. Refer to <a href="#">BCS-49, "DTC Index"</a> .
CAN DIAG SUPPORT MNTR	Monitors the reception status of CAN communication viewed from BCM.
DATA MONITOR	The BCM input/output signals are displayed.
ACTIVE TEST	The signals used to activate each device are forcibly supplied from BCM.
ECU IDENTIFICATION	The BCM part number is displayed.
CONFIGURATION	<ul style="list-style-type: none"><li>• Enables to read and save the vehicle specification.</li><li>• Enables to write the vehicle specification when replacing BCM.</li></ul>

### DATA MONITOR

#### Display Item List

Monitor item name "operation or unit"	Contents
IGN ON SW "ON/OFF"	Displays "IGN Position (ON)/OFF, ACC Position (OFF)" status as judged from ignition switch signal.
COMP ON SIG "ON/OFF"	Displays "COMP (ON)/COMP (OFF)" status as judged from air conditioner switch signal.
FAN ON SIG "ON/OFF"	Displays "FAN (ON)/FAN (OFF)" status as judged from blower motor switch signal.

## COMPONENT DIAGNOSIS

### MODE DOOR MOTOR

#### System Description

INFOID:000000003081773

#### SYSTEM DESCRIPTION

##### Component Parts

Mode door control system components are:

- Front air control
- Mode door motor
- PBR (built into mode door motor)
- Intake sensor

##### System Operation

The mode door position (vent, B/L, foot, D/F, and defrost) is set by the front air control by means of the mode door motor. When a mode door position is selected on the front air control, voltage is applied to one circuit of the mode door motor while ground is applied to the other circuit, causing the mode door motor to rotate. The direction of rotation is determined by which circuit has voltage applied to it, and which one has ground applied to it. The front air control monitors the mode door position by measuring the voltage signal on the PBR circuit.

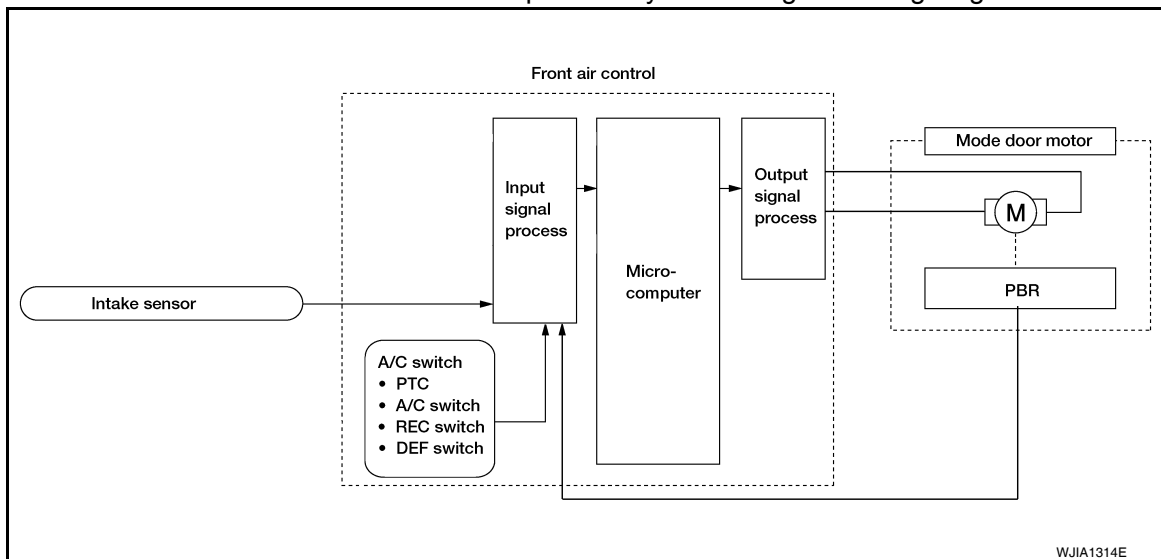

#### COMPONENT DESCRIPTION

##### Mode Door Motor

The mode door motor is attached to the heater and cooling unit assembly. It rotates so that air is discharged from the outlet as indicated by the front air control. Motor rotation is conveyed to a link which activates the mode door.

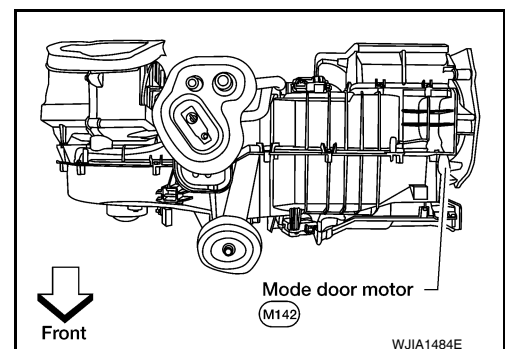

#### Mode Door Motor Component Function Check

INFOID:000000003081774

##### SYMPTOM:

- Air outlet does not change.
- Mode door motor does not operate normally.



# MODE DOOR MOTOR

[MANUAL AIR CONDITIONER]

< COMPONENT DIAGNOSIS >

## INSPECTION FLOW

### 1. CONFIRM SYMPTOM BY PERFORMING OPERATIONAL CHECK - DISCHARGE AIR

1. Turn blower control dial to 4.
2. Turn the mode dial and check all positions.
3. Confirm that discharge air comes out according to the air distribution table. Refer to [HAC-11, "Discharge Air Flow"](#).

**NOTE:**

Confirm that the compressor clutch is engaged (visual inspection) and intake door position is at FRESH when DEF (☼) or D/F (☼) is selected.

Can a symptom be duplicated?

- YES >> GO TO 3.  
NO >> GO TO 2.

### 2. PERFORM COMPLETE OPERATIONAL CHECK

Perform a complete operational check and check for any symptoms. Refer to [HAC-4, "Operational Check"](#).

Can a symptom be duplicated?

- YES >> Refer to [HAC-52, "Symptom Matrix Chart"](#).  
NO >> System OK.

### 3. CHECK FOR SERVICE BULLETINS

Check for any service bulletins.

>> GO TO 4.

### 4. CHECK MODE DOOR OPERATION

Check and verify mode door mechanism for smooth operation in each mode.

Is inspection result normal?

- YES >> GO TO 5.  
NO >> Repair as necessary.

### 5. CHECK THE MODE DOOR MOTOR PBR CIRCUIT

Perform diagnostic procedure for the mode door motor. Refer to [HAC-17, "Mode Door Motor Diagnosis Procedure"](#).

Is inspection result normal?

- YES >> GO TO 6.  
NO >> Repair PBR circuit or replace motor.

### 6. RECHECK FOR SYMPTOMS

Perform a complete operational check and check for any symptoms. Refer to [HAC-4, "Operational Check"](#).

Does another symptom exist?

- YES >> Repair as necessary.  
NO >> Replace front air control. Refer to [VTL-7, "Removal and Installation"](#).

## Mode Door Motor Diagnosis Procedure

INFOID:000000003081775

### MODE DOOR MOTOR DIAGNOSTIC PROCEDURE

#### 1. CHECK POWER SUPPLY AND GROUND CIRCUITS FOR MODE DOOR MOTOR

# MODE DOOR MOTOR

[MANUAL AIR CONDITIONER]

## < COMPONENT DIAGNOSIS >

1. Turn ignition switch OFF.
2. Disconnect front air control connector and mode door motor connector.
3. Check continuity between front air control harness connector M49 (A) terminal 1 and mode door motor harness connector M142 (B) terminal 1 and between front air control harness connector M49 (A) terminal 14 and mode door motor harness connector M142 (B) terminal 6.

**1 - 1** : Continuity should exist.  
**14 - 6** : Continuity should exist.

### Is inspection result normal?

- YES >> GO TO 2.  
NO >> Repair or replace harness as necessary.

## 2. CHECK PBR REFERENCE SIGNAL VOLTAGE

1. Reconnect the front air control connector.
2. Turn ignition switch ON.
3. Check voltage between mode door motor harness connector M142 terminal 3 and ground.

**3 - Ground** : Approx. 5V

### Is inspection result normal?

- YES >> GO TO 4.  
NO >> GO TO 3.

## 3. CHECK PBR REFERENCE VOLTAGE CIRCUIT BETWEEN MODE DOOR AND FRONT AIR CONTROL

1. Turn ignition switch OFF.
2. Disconnect the front air control connector.
3. Check continuity between front air control harness connector M49 (A) terminal 23 and mode door motor harness connector M142 (B) terminal 3.

**23 - 3** : Continuity should exist.

### Is inspection result normal?

- YES >> Replace front air control. Refer to [VTL-7, "Removal and Installation"](#).  
NO >> Repair or replace harness as necessary.

## 4. CHECK PBR GROUND REFERENCE CIRCUIT

1. Turn ignition switch OFF.
2. Disconnect the front air control connector.
3. Check continuity between front air control harness connector M49 (A) terminal 26 and mode door motor harness connector M142 (B) terminal 2.

**26 - 2** : Continuity should exist.

### Is inspection result normal?

- YES >> GO TO 5.  
NO >> Repair or replace harness as necessary.

## 5. CHECK PBR FEEDBACK SIGNAL

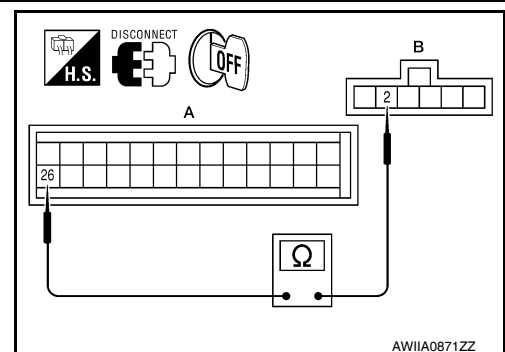
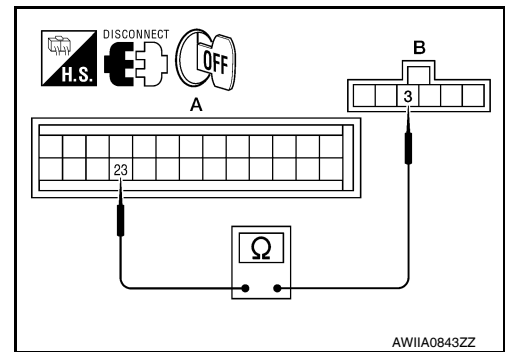
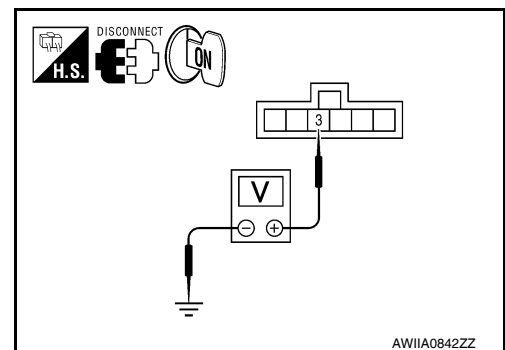
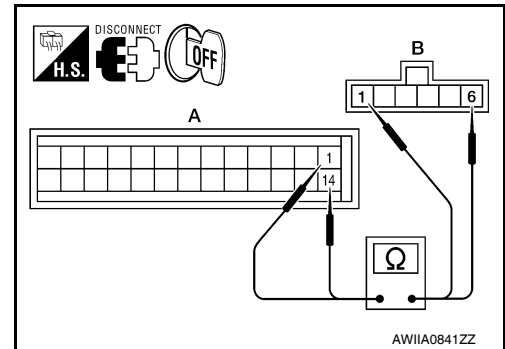

# MODE DOOR MOTOR

[MANUAL AIR CONDITIONER]

## < COMPONENT DIAGNOSIS >

1. Reconnect the front air control connector and mode door motor connector.
2. Turn ignition switch ON.
3. Check voltage between front air control harness connector M49 terminal 21 and ground.
4. Press mode switch through all modes.

**21 - Ground**

**: Approx. 0 - 5V**

Is inspection result normal?

YES >> Replace front air control. Refer to [VTL-7, "Removal and Installation"](#).

NO >> GO TO 6.

## 6. CHECK PBR FEEDBACK CIRCUIT

1. Turn ignition switch OFF.
2. Disconnect the mode door motor connector and front air control harness connector.
3. Check continuity between front air control harness connector M49 (A) terminal 21 and mode door motor harness connector M142 (B) terminal 4.

**21 - 4**

**: Continuity should exist.**

Is inspection result normal?

YES >> Replace mode door motor. Refer to [VTL-17, "Removal and Installation"](#).

NO >> Repair or replace harness as necessary.

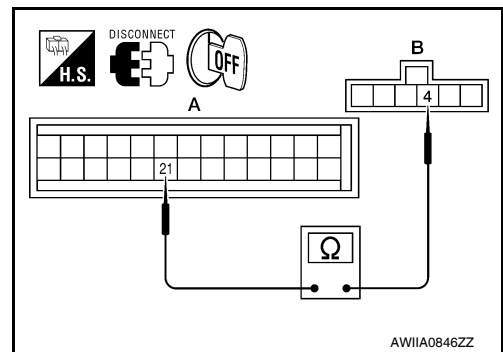
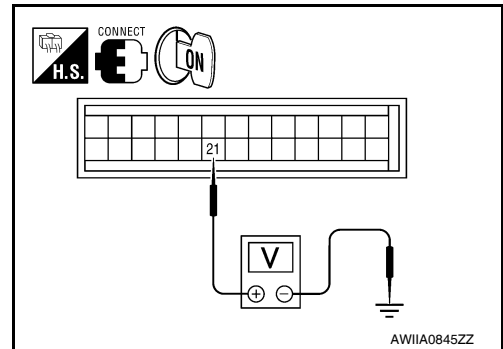

A  
B  
C  
D  
E  
F  
G  
H  
J  
K  
L  
M  
N  
O  
P

HAC

## AIR MIX DOOR MOTOR

### System Description

INFOID:000000003081776

#### SYSTEM DESCRIPTION

##### Component Parts

Air mix door control system components are:

- Front air control
- Air mix door motor
- PBR (built into air mix door motor)
- Intake sensor

##### System Operation

The front air control receives data from the temperature selected by the driver. The front air control then applies a voltage to one circuit of the air mix door motor, while ground is applied to the other circuit, causing the air mix door motor to rotate. The direction of rotation is determined by which circuit has voltage applied to it, and which one has ground applied to it. The front air control monitors the air mix door positions by measuring the voltage signal on the PBR circuits of each door.

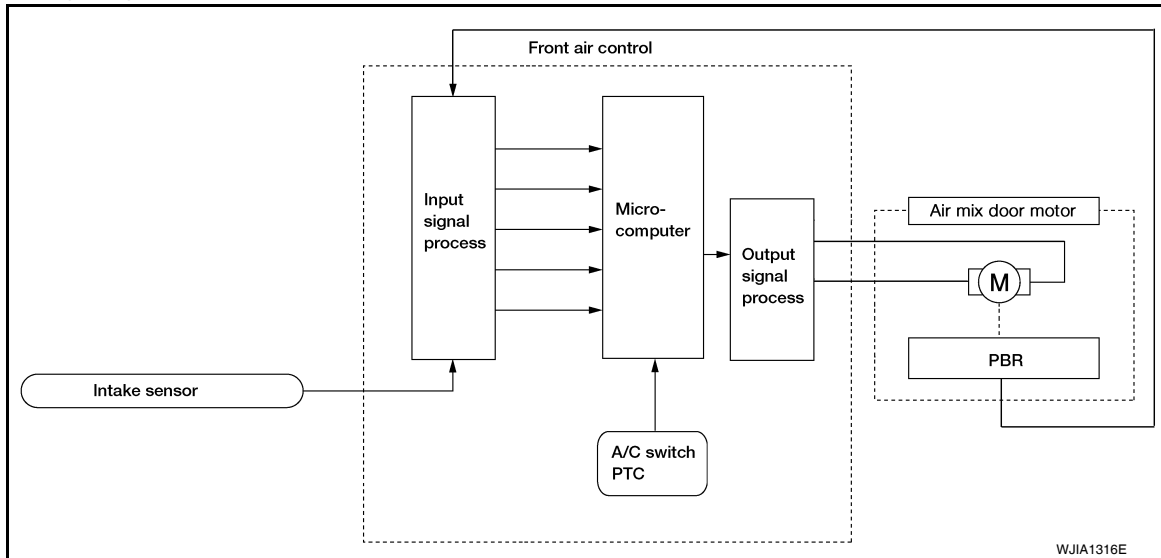

##### Air Mix Door Control Specification

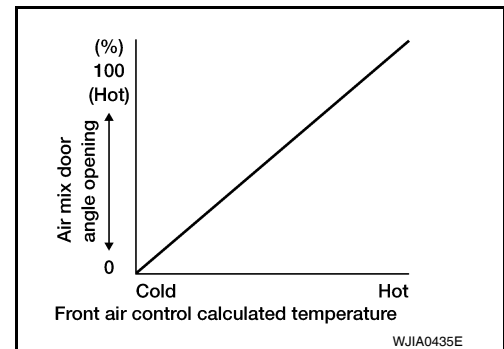

#### COMPONENT DESCRIPTION

##### Air Mix Door Motor

# AIR MIX DOOR MOTOR

[MANUAL AIR CONDITIONER]

## < COMPONENT DIAGNOSIS >

The air mix door motor is attached to the heater and cooling unit assembly. This motor rotates so that the air mix door is opened or closed to a position set by the front air control. Motor rotation is then conveyed through a shaft and the air mix door position is then fed back to the front air control by the PBR built into the air mix door motor.

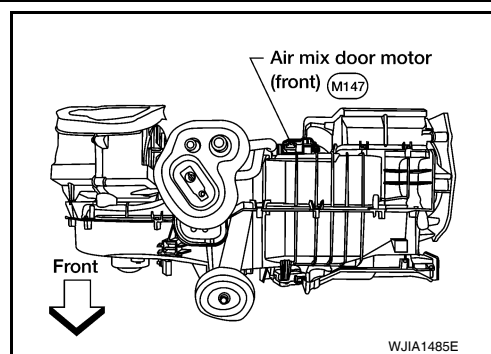

## Air Mix Door Motor Component Function Check

INFOID:000000003081777

### INSPECTION FLOW

#### 1. CONFIRM SYMPTOM BY PERFORMING OPERATIONAL CHECK - TEMPERATURE INCREASE

1. Blower must be on (1, 2, 3, 4).
2. Turn the temperature control dial clockwise to maximum heat.
3. Check for hot air at discharge air outlets.

>> GO TO 2.

#### 2. CONFIRM SYMPTOM BY PERFORMING OPERATIONAL CHECK - TEMPERATURE DECREASE

1. Turn the temperature control dial counterclockwise to maximum cold.
2. Check for cold air at discharge air outlets.

##### Can a symptom be duplicated?

- YES >> GO TO 4.  
NO >> GO TO 3.

#### 3. PERFORM COMPLETE OPERATIONAL CHECK

Perform a complete operational check and check for any symptoms. Refer to [HAC-4, "Operational Check"](#).

##### Can a symptom be duplicated?

- YES >> Refer to [HAC-52, "Symptom Matrix Chart"](#).  
NO >> System OK.

#### 4. CHECK FOR SERVICE BULLETINS

Check for any service bulletins.

>> GO TO 5.

#### 5. CHECK AIR MIX DOOR OPERATION

Check and verify air mix door mechanism for smooth operation from maximum cold to maximum heat in each mode.

##### Is the inspection result normal?

- YES >> GO TO 6.  
NO >> Repair as necessary.

#### 6. CHECK THE AIR MIX DOOR MOTOR PBR CIRCUIT

Perform diagnostic procedure for the air mix door motor. Refer to [HAC-22, "Air Mix Door Motor Diagnosis Procedure"](#).

##### Is the inspection result normal?

- YES >> GO TO 7.  
NO >> Repair PBR circuit or replace air mix door motor. Refer to [VTL-18, "Removal and Installation"](#).

#### 7. RECHECK FOR ANY SYMPTOMS

Perform a complete operational check for any symptoms. Refer to [HAC-4, "Operational Check"](#).

# AIR MIX DOOR MOTOR

[MANUAL AIR CONDITIONER]

< COMPONENT DIAGNOSIS >

Does another symptom exist?

- YES >> Refer to [HAC-52, "Symptom Matrix Chart"](#).
- NO >> Replace front air control. Refer to [VTL-7, "Removal and Installation"](#).

## Air Mix Door Motor Diagnosis Procedure

INFOID:000000003081778

### DIAGNOSTIC PROCEDURE FOR AIR MIX DOOR MOTOR

#### 1. CHECK POWER SUPPLY CIRCUITS FOR AIR MIX DOOR MOTOR

1. Turn ignition switch OFF.
2. Disconnect front air control connector and air mix door motor connector.
3. Check continuity between front air control harness connector M49 terminal 2 and 3 and air mix door motor harness connector M147 terminal 6 and 5.

**2 - 6 : Continuity should exist.**  
**3 - 5 : Continuity should exist.**

Is inspection result normal?

- YES >> GO TO 2.
- NO >> Repair or replace harness as necessary.

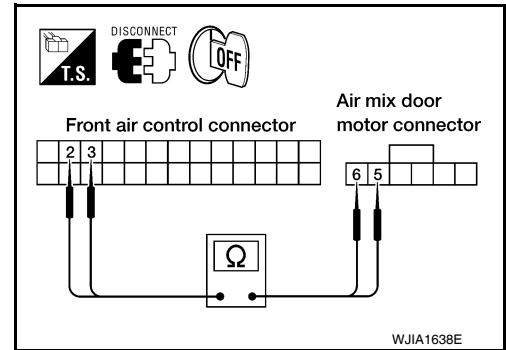

#### 2. CHECK PBR REFERENCE SIGNAL VOLTAGE

1. Reconnect the front air control connector.
2. Turn ignition switch ON.
3. Check voltage between air mix door motor harness connector M147 terminal 1 and ground.

**1 - Ground : Approx. 5V**

Is inspection result normal?

- YES >> GO TO 4.
- NO >> GO TO 3.

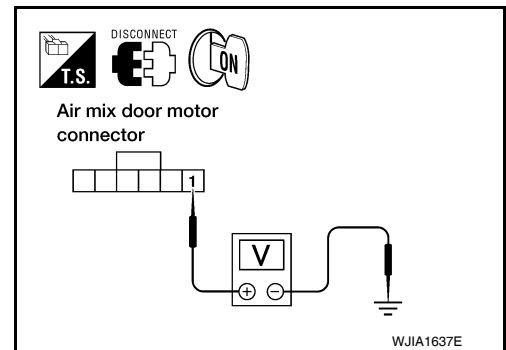

#### 3. CHECK PBR REFERENCE VOLTAGE CIRCUIT BETWEEN AIR MIX DOOR MOTOR AND FRONT AIR CONTROL

1. Turn ignition switch OFF.
2. Disconnect the front air control connector.
3. Check continuity between air mix door motor harness connector M147 (B) terminal 1 and front air control harness connector M49 (A) terminal 23.

A		B		Continuity
Connector	Terminal	Connector	Terminal	
Front air control: M49	23	Air mix door motor : M143	1	Yes

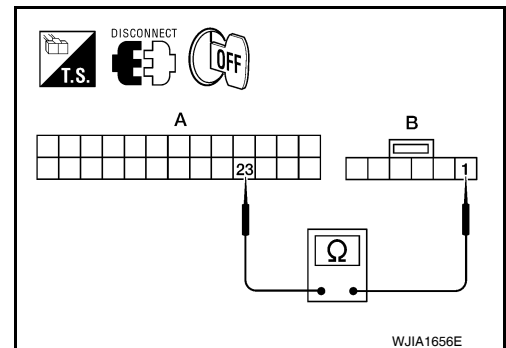

Is inspection result normal?

- YES >> Replace front air control. Refer to [VTL-7, "Removal and Installation"](#).
- NO >> Repair or replace harness as necessary.

#### 4. CHECK PBR GROUND REFERENCE CIRCUIT

# AIR MIX DOOR MOTOR

[MANUAL AIR CONDITIONER]

## < COMPONENT DIAGNOSIS >

1. Turn ignition switch OFF.
2. Disconnect the front air control connector.
3. Check continuity between air mix door motor harness connector M147 terminal 3 and front air control harness connector M49 terminal 26.

**3 - 26 : Continuity should exist.**

Is inspection result normal?

- YES >> GO TO 5.  
NO >> Repair or replace harness as necessary.

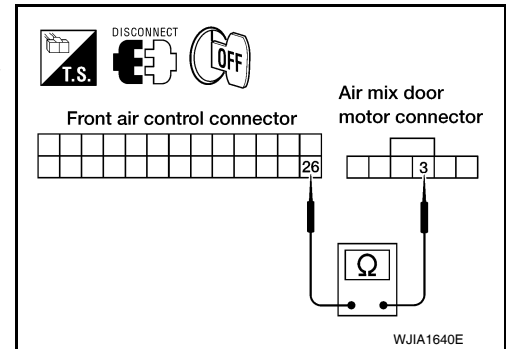

## 5. CHECK PBR FEEDBACK SIGNAL

1. Reconnect the front air control connector and air mix door motor connector.
2. Turn ignition switch ON.
3. Check voltage between front air control harness connector M49 terminal 22 and ground.
4. Rotate temperature control dial through complete range.

**22 - Ground : Approx. 0V - 5V**

Is inspection result normal?

- YES >> Replace front air control. Refer to [VTL-7, "Removal and Installation"](#).  
NO >> GO TO 6.

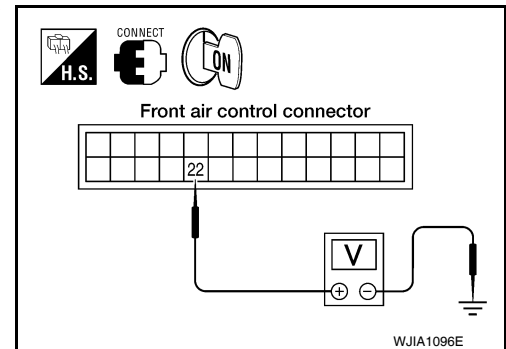

## 6. CHECK PBR FEEDBACK CIRCUIT

1. Turn ignition switch OFF.
2. Disconnect the air mix door motor connector and front air control connector.
3. Check continuity between air mix door motor harness connector M147 terminal 2 and front air control harness connector M49 terminal 22.

**2 - 22 : Continuity should exist.**

Is inspection result normal?

- YES >> Replace air mix door motor. Refer to [VTL-18, "Removal and Installation"](#).  
NO >> Repair or replace harness as necessary.

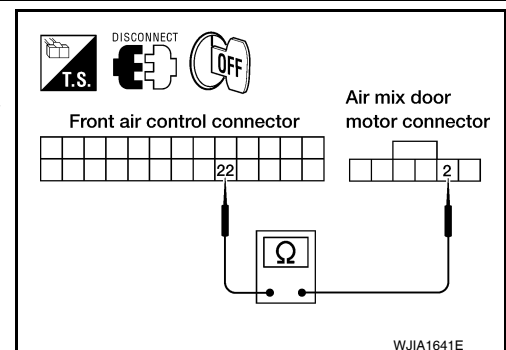

A  
B  
C  
D  
E  
F  
G  
H  
HAC  
J  
K  
L  
M  
N  
O  
P

## INTAKE DOOR MOTOR

### System Description

INFOID:000000003081779

### SYSTEM DESCRIPTION

#### Component Parts

Intake door control system components are:

- Front air control
- Intake door motor
- Intake sensor

#### System Operation

The intake door control determines the intake door position based on the position of the recirculation switch. When the recirculation switch is depressed the intake door motor rotates closing off the fresh air inlet and recirculating the cabin air. If the recirculation switch is depressed again, the intake door motor rotates in the opposite direction, again allowing fresh air into the cabin.

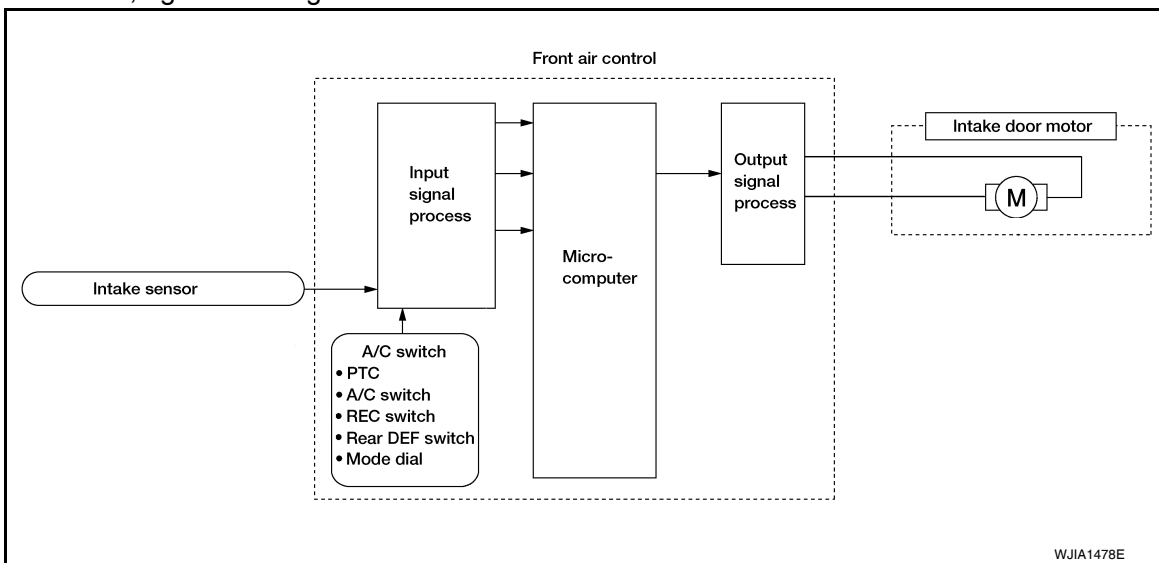

### COMPONENT DESCRIPTION

#### Intake door motor

The intake door motor is attached to the intake unit. It rotates so that air is drawn from inlets set by the front air control. Motor rotation is conveyed to a lever which activates the intake door.

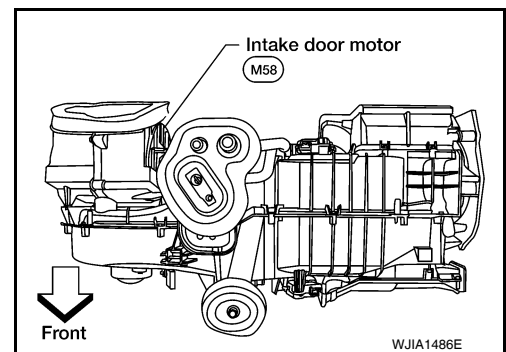

### Intake Door Motor Component Function Check

INFOID:000000003081780

#### SYMPTOM:

- Intake door does not change.
- Intake door motor does not operate normally.

#### INSPECTION FLOW

**1**. CONFIRM SYMPTOM BY PERFORMING OPERATIONAL CHECK - REC ( )



1. Turn blower control dial to 4.



# INTAKE DOOR MOTOR

[MANUAL AIR CONDITIONER]

## < COMPONENT DIAGNOSIS >

2. Turn mode dial to vent mode (  ).
3. Press REC (  ) switch.
4. Press REC (  ) switch again.
5. Listen for intake door position change (you should hear blower sound change slightly).

### Can a symptom be duplicated?

- YES >> GO TO 3.  
NO >> GO TO 2.

## 2.PERFORM COMPLETE OPERATIONAL CHECK

Perform a complete operational check and check for any symptoms. Refer to [HAC-4. "Operational Check"](#).

### Can a symptom be duplicated?

- YES >> Refer to [HAC-52. "Symptom Matrix Chart"](#).  
NO >> System OK.

## 3.CHECK FOR SERVICE BULLETINS

Check for any service bulletins.

>> GO TO 4.

## 4.CHECK INTAKE DOOR OPERATION

Check and verify intake door mechanism for smooth operation.

### Is inspection result normal?

- YES >> GO TO 5.  
NO >> Repair intake door mechanism.

## 5.RECHECK FOR ANY SYMPTOMS

Perform a complete operational check for any symptoms. Refer to [HAC-4. "Operational Check"](#).

### Does another symptom exist?

- YES >> Refer to [HAC-52. "Symptom Matrix Chart"](#).  
NO >> Replace front air control. Refer to [VTL-7. "Removal and Installation"](#).

## Intake Door Motor Diagnosis Procedure

INFOID:000000003081781

## DIAGNOSTIC PROCEDURE FOR INTAKE DOOR MOTOR

### 1.CHECK INTAKE DOOR MOTOR CIRCUIT VOLTAGE

1. Turn ignition switch OFF.
2. Disconnect intake door motor connector.
3. Turn ignition switch ON.
4. Rotate the temperature control dial counterclockwise.
5. Check voltage between intake door motor harness connector M58 terminal 6 and ground.

**6 - Ground** : **Battery voltage**

### Is inspection result normal?

- OK >> GO TO 3.  
NG >> GO TO 2.

### 2.CHECK INTAKE DOOR MOTOR CIRCUIT FOR OPEN

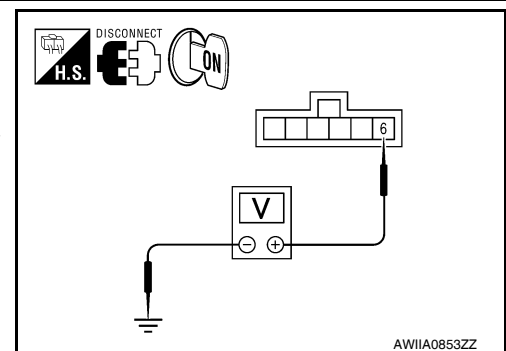

# INTAKE DOOR MOTOR

[MANUAL AIR CONDITIONER]

## < COMPONENT DIAGNOSIS >

1. Turn ignition switch OFF.
2. Disconnect front air control connector.
3. Check continuity between front air control harness connector M49 (A) terminal 5 and intake door motor harness connector M58 (B) terminal 6.

**5 - 6 : Continuity should exist.**

Is inspection result normal?

- OK >> Replace front air control connector. Refer to [VTL-7. "Removal and Installation"](#).
- NG >> Repair or replace harness as necessary.

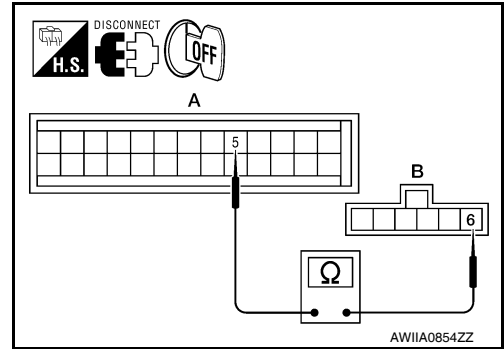

## 3. CHECK INTAKE DOOR MOTOR CIRCUIT VOLTAGE

1. Rotate the temperature control dial clockwise.
2. Check voltage between intake door motor harness connector M58 terminal 1 and ground.

**1 - Ground : Battery voltage**

Is inspection result normal?

- YES >> Replace intake door motor. Refer to [VTL-16. "Removal and Installation"](#).
- NO >> GO TO 4.

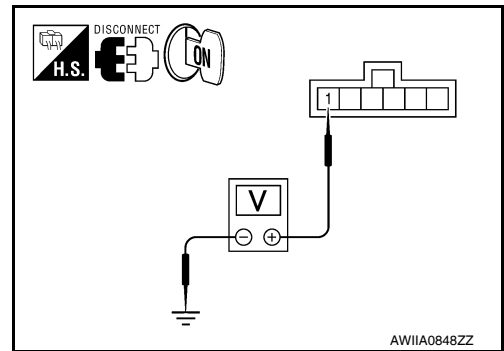

## 4. CHECK INTAKE DOOR MOTOR CIRCUIT FOR OPEN

1. Turn ignition switch OFF.
2. Disconnect front air control connector.
3. Check continuity between front air control harness connector M49 (A) terminal 4 and intake door motor harness connector M58 (B) terminal 1.

A		B		Continuity
Connector	Terminal	Connector	Terminal	
Front air control: M49	4	Intake door motor: M58	1	Yes

Is inspection result normal?

- YES >> Replace front air control connector. Refer to [VTL-7. "Removal and Installation"](#).
- NO >> Repair or replace harness as necessary.

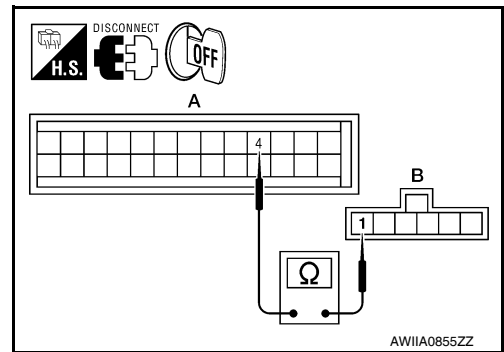

## BLOWER MOTOR

### System Description

INFOID:000000003081782

#### Component Parts

Blower speed control system components are:

- Front air control
- Front blower motor resistor
- Front blower motor
- Front blower relay

#### System Operation

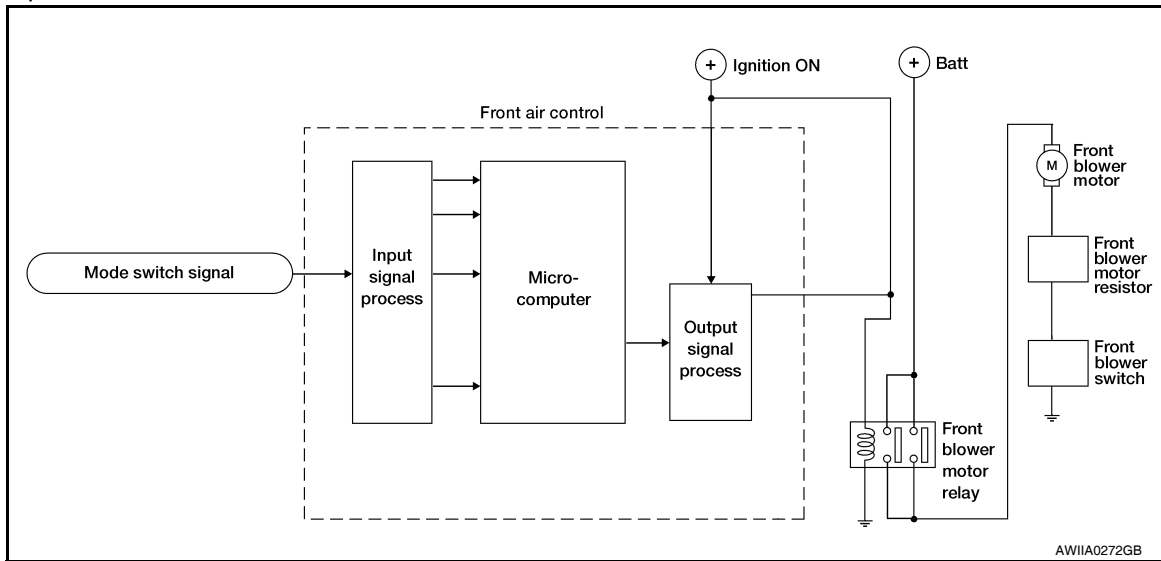

### COMPONENT DESCRIPTION

#### Blower Motor Resistor

The front blower motor resistor (1) is located on the heater and cooling unit assembly. The front blower motor resistor grounds the front blower motor through a series of 1, 2, or 3 resistors, depending upon speed selected. For high speed operation the front blower motor resistor is circumvented and the front blower motor grounds directly.

⇒: Front

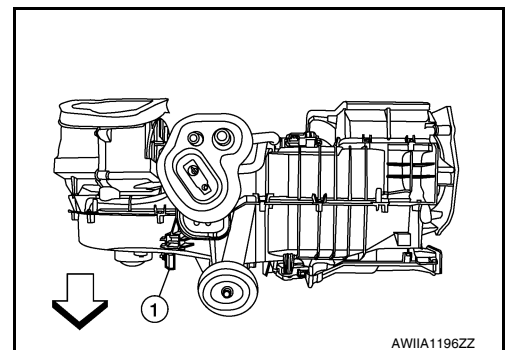

### Front Blower Motor Component Function Check

INFOID:000000003081783

#### INSPECTION FLOW

##### 1. CONFIRM SYMPTOM BY PERFORMING OPERATIONAL CHECK - FRONT BLOWER

1. Rotate the blower control dial clockwise. Blower should operate.
2. Rotate the blower control dial clockwise, and continue checking blower speed until all speeds are checked.

Can the symptom be duplicated?

A  
B  
C  
D  
E  
F  
G  
H  
HAC  
J  
K  
L  
M  
N  
O  
P

# BLOWER MOTOR

[MANUAL AIR CONDITIONER]

## < COMPONENT DIAGNOSIS >

- YES >> GO TO 3.
- NO >> GO TO 2.

### 2.CHECK FOR ANY SYMPTOMS

Perform a complete operational check for any symptoms. Refer to [HAC-4, "Operational Check"](#).

#### Does another symptom exist?

- YES >> Refer to [HAC-52, "Symptom Matrix Chart"](#).
- NO >> System OK.

### 3.CHECK FOR SERVICE BULLETINS

Check for any service bulletins.

>> GO TO 4.

### 4.CHECK BLOWER MOTOR OPERATION

Check and verify blower motor operates in all speeds.

#### Does blower motor operate in all speeds?

- YES >> GO TO 5.
- NO >> Refer to [HAC-28, "Front Blower Motor Diagnosis Procedure"](#).

### 5.CHECK ENGINE COOLANT TEMPERATURE SENSOR CIRCUIT

Perform diagnostic procedure for the coolant temperature sensor circuit. Refer to [EC-126, "Component Inspection"](#).

#### Is the inspection result normal?

- YES >> GO TO 6.
- NO >> Repair or replace harness as necessary.

### 6.RECHECK FOR ANY SYMPTOMS

Perform a complete operational check for any symptoms. Refer to [HAC-4, "Operational Check"](#).

#### Does another symptom exist?

- YES >> Refer to [HAC-52, "Symptom Matrix Chart"](#).
- NO >> Replace front air control. Refer to [VTL-7, "Removal and Installation"](#).

## Front Blower Motor Diagnosis Procedure

INFOID:000000003081784

SYMPTOM: Blower motor operation is malfunctioning under starting blower speed control.

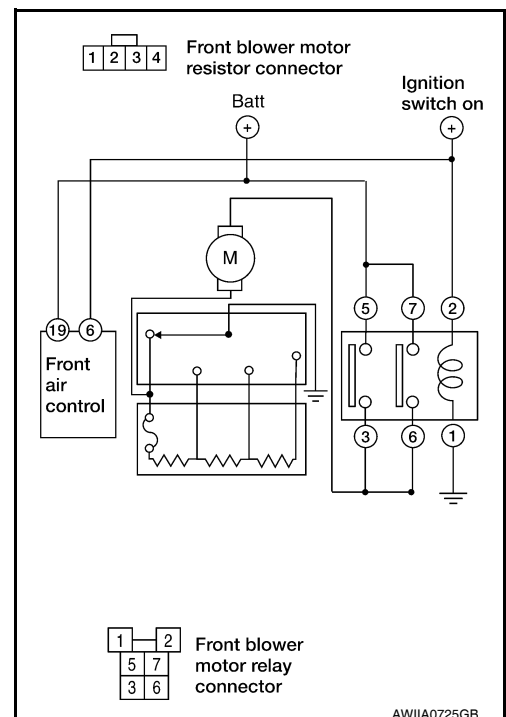

AWIIA0725GB

# BLOWER MOTOR

< COMPONENT DIAGNOSIS >

[MANUAL AIR CONDITIONER]

## 1. DIAGNOSTIC PROCEDURE

1. Turn ignition switch ON.
2. Turn the front blower switch to each of its four speeds.  
Does blower motor rotate normally at each speed?

### YES or NO

- YES >> Inspection End.  
 NO >> 1. Does not rotate at any speed, GO TO 2.  
 2. Does not rotate at 1 - 3 speed, GO TO 13.  
 3. Does not rotate at 4 speed, GO TO 16.

## 2. CHECK FUSES

1. Check 15A fuses (Nos. 24 and 27, located in the fuse and fusible link box). Refer to [PG-70. "Terminal Arrangement"](#).
2. Check 10A fuse [No. 8, located in the fuse block (JB)]. Refer to [PG-69. "Terminal Arrangement"](#).

### Is inspection result normal?

- YES >> GO TO 3.  
 NO >> GO TO 8.

## 3. CHECK FRONT BLOWER MOTOR POWER SUPPLY

1. Turn ignition switch OFF.
2. Disconnect front blower motor harness connector.
3. Turn ignition switch ON.
4. Select any front blower speed except OFF.
5. Check voltage between front blower motor harness connector M62 terminal 2 and ground.

**2 - Ground : Battery voltage**

### Is inspection result normal?

- YES >> GO TO 12.  
 NO >> GO TO 4.

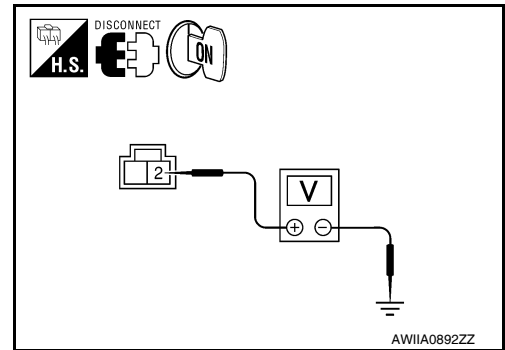

## 4. CHECK FRONT BLOWER MOTOR RELAY

1. Turn Ignition switch OFF.
2. Check front blower motor relay. Refer to [HAC-32. "Front Blower Motor Component Inspection"](#).

### Is inspection result normal?

- YES >> GO TO 5.  
 NO >> Replace front blower motor relay.

## 5. CHECK FRONT BLOWER MOTOR RELAY POWER SUPPLY (SWITCH SIDE)

Check voltage between front blower motor relay harness connector E54 terminals 7 and 5 and ground.

Front blower motor relay			Condition	Voltage (Approx.)
(+)		(-)		
Connector	Terminal			
E54	5	Ground	Blower motor relay power supply	Battery voltage
E54	7	Ground	Blower motor relay power supply	Battery voltage

### Is inspection result normal?

- YES >> GO TO 6.  
 NO >> Repair harness or connector.

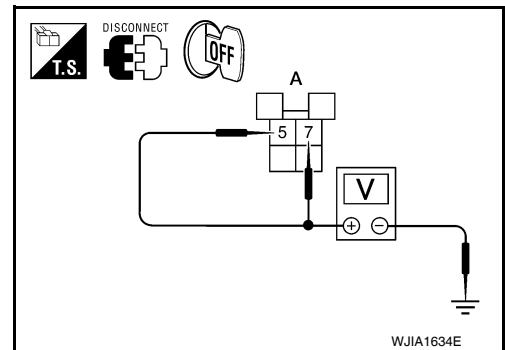

# BLOWER MOTOR

< COMPONENT DIAGNOSIS >

[MANUAL AIR CONDITIONER]

## 6. CHECK FRONT BLOWER MOTOR RELAY POWER SUPPLY (COIL SIDE)

1. Turn ignition switch ON.
2. Check voltage between front blower motor relay harness connector E54 terminal 2 and ground.

Front blower motor relay			Condition	Voltage (Approx.)
(+)		(-)		
Connector	Terminal			
E54	2	Ground	Blower motor relay power supply (coil side)	Battery voltage

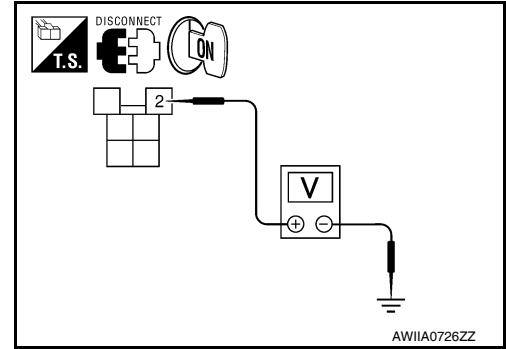

Is inspection result normal?

- YES >> GO TO 7.  
 NO >> Repair or replace harness as necessary.

## 7. CHECK FRONT BLOWER MOTOR POWER FROM RELAY TO FRONT BLOWER MOTOR

1. Turn ignition switch OFF.
2. Check continuity between front blower motor relay harness connector E54 (A) terminals 6 and 3 and front blower motor harness connector M62 (B) terminal 2.

**3, 6 - 2 : Continuity should exist.**

Is inspection result normal?

- YES >> Repair the blower motor ground circuit as necessary.  
 NO >> Repair harness or connector between the front blower motor relay and the front blower motor.

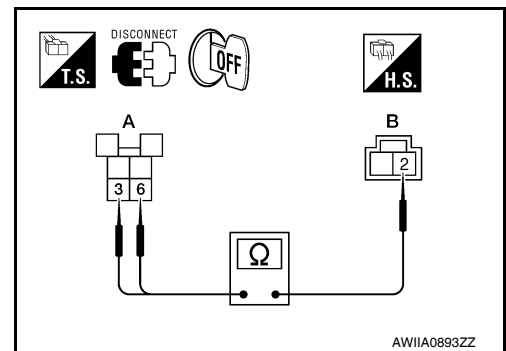

## 8. REPLACE FUSE

Refer to [PG-71, "Terminal Arrangement"](#).

Does fuse No. 24 or 27 open when the front blower motor is turned on?

YES or NO

- YES >> GO TO 10.  
 NO >> GO TO 9.

## 9. REPLACE FUSE

Refer to [PG-71, "Terminal Arrangement"](#).

Does fuse No. 8 open when the ignition switch is turned ON?

YES or NO

- YES >> Repair or replace harness as necessary.  
 NO >> Inspection End.

## 10. CHECK FRONT BLOWER MOTOR POWER SUPPLY CIRCUIT FOR SHORT

1. Turn ignition switch OFF.
2. Disconnect front blower motor connector.
3. Check continuity between front blower motor harness connector M62 terminal 2 and ground.

**2 - Ground : Continuity should not exist.**

Is inspection result normal?

- YES >> GO TO 11.  
 NO >> Repair or replace harness as necessary.

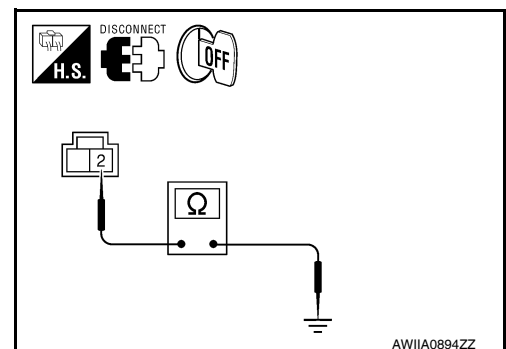

# BLOWER MOTOR

< COMPONENT DIAGNOSIS >

[MANUAL AIR CONDITIONER]

## 11. CHECK FRONT BLOWER MOTOR RELAY (SWITCH SIDE) POWER SUPPLY CIRCUIT FOR SHORT

1. Disconnect front blower motor relay connector.
2. Check continuity between the front blower motor relay harness connector E54 terminal 7 and terminal 5 and ground.

**7, 5 - Ground : Continuity should not exist.**

Is inspection result normal?

- YES >> Check front blower motor. Refer to [HAC-28. "Front Blower Motor Diagnosis Procedure"](#).
- NO >> Repair harness or connector.

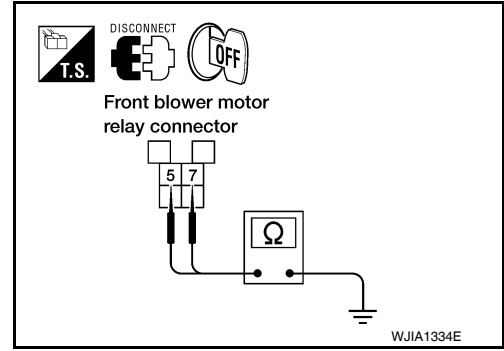

## 12. CHECK FRONT BLOWER MOTOR

1. Turn ignition switch OFF.
2. Check front blower motor. Refer to [HAC-32. "Front Blower Motor Component Inspection"](#).

Is inspection result normal?

- YES >> GO TO 13.
- NO >> Replace front blower motor. Refer to [PG-71. "Terminal Arrangement"](#).

## 13. CHECK FRONT BLOWER MOTOR RESISTOR

Check front blower motor resistor. Refer to [HAC-32. "Front Blower Motor Component Inspection"](#).

Is inspection result normal?

- YES >> GO TO 14.
- NO >> Replace front blower motor resistor. Refer to [VTL-10. "Removal and Installation"](#).

## 14. CHECK FRONT BLOWER SWITCH

Check front blower switch. Refer to [HAC-32. "Front Blower Motor Component Inspection"](#).

Is inspection result normal?

- YES >> GO TO 15.
- NO >> Replace front blower switch. Refer to [VTL-7. "Removal and Installation"](#).

## 15. CHECK FRONT BLOWER MOTOR GROUND CIRCUIT TO FRONT BLOWER MOTOR RESISTOR

1. Disconnect front blower motor resistor harness connector.
2. Check continuity between front blower motor connector M62 (A) terminal 1 and front blower motor resistor harness connector M122 (B) terminal 3.

A		B		Continuity
Connector	Terminal	Connector	Terminal	
Front blower motor: M62	1	Front blower motor resistor: M122	3	Yes

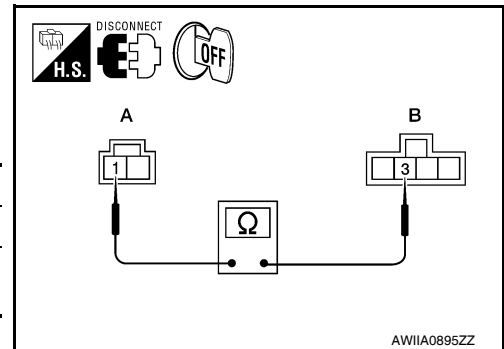

Is inspection result normal?

- YES >> Repair harness or connector between front blower switch connector M51 terminal 8 and ground.
- NO >> Repair harness or connector between front blower motor resistor and front blower motor.

## 16. CHECK FRONT BLOWER SWITCH

Check front blower switch. Refer to [HAC-32. "Front Blower Motor Component Inspection"](#).

Is inspection result normal?

- YES >> Repair harness or connector between front blower motor switch connector M51 terminal 8 and front blower motor resistor connector M122 terminal 3.
- NO >> Replace front blower switch. Refer to [VTL-7. "Removal and Installation"](#).

SYMPTOM: Blower motor operation is malfunctioning.

# BLOWER MOTOR

< COMPONENT DIAGNOSIS >

[MANUAL AIR CONDITIONER]

## Front Blower Motor Component Inspection

INFOID:000000003081785

### COMPONENT INSPECTION

#### Front Blower Motor Relay

Check continuity between terminals by supplying 12 volts and ground to coil side terminals of relay.

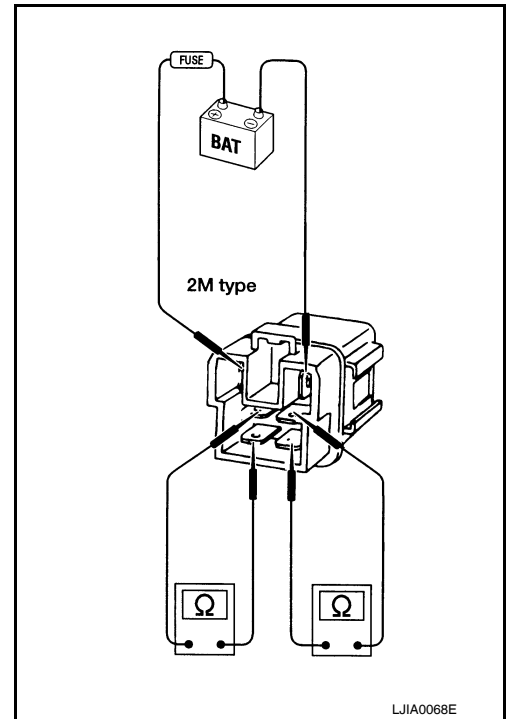

#### Front Blower Motor

Confirm smooth rotation of the blower motor.

- Ensure that there are no foreign particles inside the blower unit.
- Apply 12 volts to terminal 2 and ground to terminal 1 and verify that the motor operates freely and quietly.

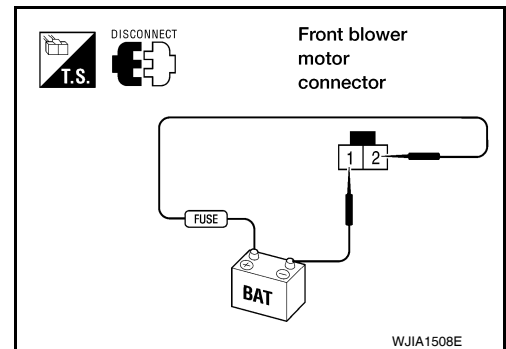

#### Front Blower Switch

Check continuity between terminals at each switch position.

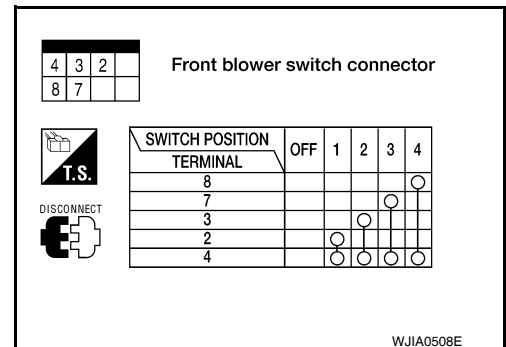

#### Blower Motor Resistor



# BLOWER MOTOR

## < COMPONENT DIAGNOSIS >

Check continuity between terminals. There will be resistance, but there should not be an open or short between any two terminals.

## [MANUAL AIR CONDITIONER]

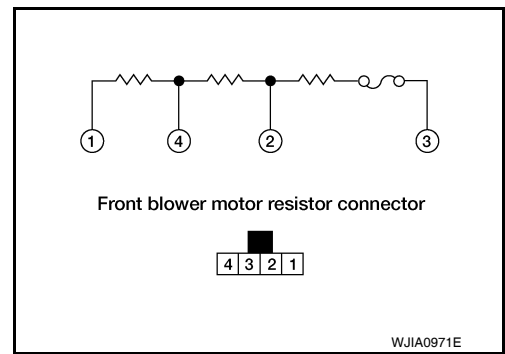

- A
- B
- C
- D
- E
- F
- G
- H
- HAC
- J
- K
- L
- M
- N
- O
- P

## MAGNET CLUTCH

### System Description

INFOID:000000003081786

#### SYSTEM DESCRIPTION

The front air control controls compressor operation based on ambient and intake temperature and a signal from ECM.

#### Low Temperature Protection Control

The front air control will turn the compressor ON or OFF as determined by a signal detected by the intake sensor and the ambient sensor.

When intake air temperature is higher than 3.5° C (38.3° F), the compressor turns ON. The compressor turns OFF when intake air temperature is lower than 2.5° C (36.5° F).

### Magnet Clutch Component Function Check

INFOID:000000003081787

SYMPTOM: Magnet clutch does not engage.

#### INSPECTION FLOW

#### 1. CONFIRM SYMPTOM BY PERFORMING OPERATIONAL CHECK - MAGNET CLUTCH

1. Rotate blower control dial clockwise.
2. Rotate mode dial to vent (☼) position.
3. Press A/C switch. Confirm that the compressor clutch engages (sound or visual inspection).

#### Can the symptom be duplicated?

- YES >> GO TO 3.  
NO >> GO TO 2.

#### 2. CHECK FOR ANY SYMPTOMS

Perform a complete operational check for any symptoms. Refer to [HAC-4, "Operational Check"](#).

#### Does another symptom exist?

- YES >> Refer to [HAC-52, "Symptom Matrix Chart"](#).  
NO >> System OK.

#### 3. CHECK FOR SERVICE BULLETINS

Check for any service bulletins.

>> GO TO 4.

#### 4. CHECK INTAKE SENSOR

Check and verify intake sensor circuit. Refer to [HAC-40, "Intake Sensor Component Inspection"](#).

>> GO TO 5.

#### 5. RECHECK FOR ANY SYMPTOMS

Perform a complete operational check for any symptoms. Refer to [HAC-4, "Operational Check"](#).

#### Does another symptom exist?

- YES >> Refer to [HAC-52, "Symptom Matrix Chart"](#).  
NO >> Replace front air control. Refer to [VTL-7, "Removal and Installation"](#).

### Magnet Clutch Diagnosis Procedure

INFOID:000000003081788

#### DIAGNOSTIC PROCEDURE FOR MAGNET CLUTCH

# MAGNET CLUTCH

< COMPONENT DIAGNOSIS >

[MANUAL AIR CONDITIONER]

SYMPTOM: Magnet clutch does not engage when A/C switch is ON.

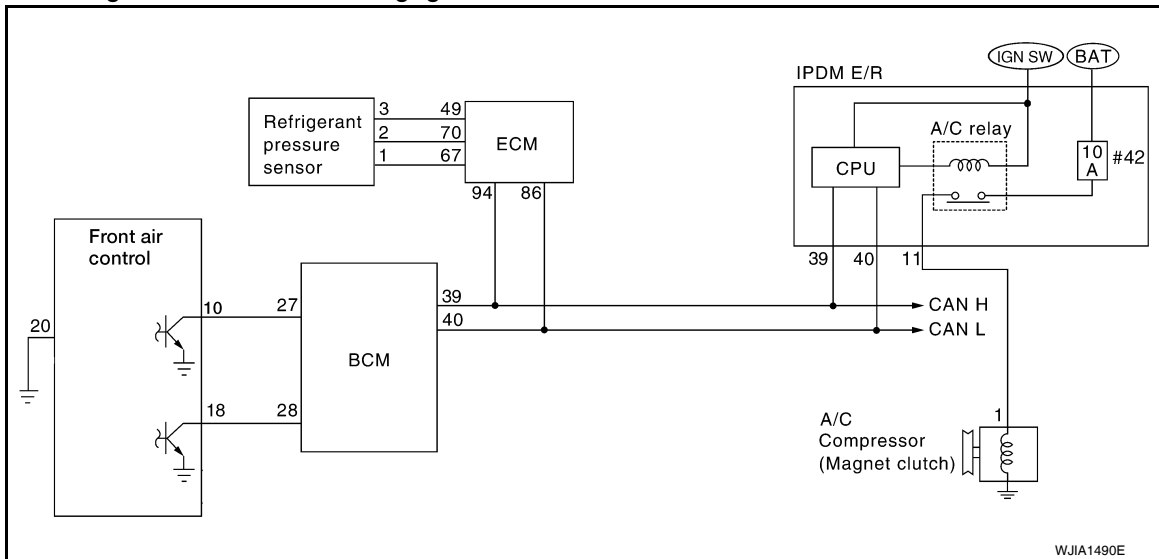

## 1. PERFORM AUTO ACTIVE TEST

Refer to [PCS-15, "CONSULT - III Function \(IPDM E/R\)"](#).

Does magnet clutch operate?

YES or NO

- YES >> •  WITH CONSULT-III  
GO TO 2.  
•  WITHOUT CONSULT-III  
GO TO 8.

NO >> Check 10A fuse (No. 42, located in IPDM E/R), and GO TO 12.

## 2. CHECK BCM INPUT (A/C COMPRESSOR ON) SIGNAL

Check A/C compressor ON/OFF signal. Refer to [HAC-15, "CONSULT-III Function \(BCM\)"](#).

**A/C SW ON : COMP ON SIG ON**  
**A/C SW OFF : COMP ON SIG OFF**

Is the inspection result normal?

- YES >> GO TO 3.  
NO >> GO TO 8.

## 3. CHECK REFRIGERANT PRESSURE SENSOR

Check refrigerant pressure sensor. Refer to [EC-424, "Diagnosis Procedure"](#).

Is the inspection result normal?

- YES >> GO TO 4.  
NO >> Replace refrigerant pressure sensor. Refer to [HA-39, "Removal and Installation for Refrigerant Pressure Sensor"](#).

## 4. CHECK BCM INPUT (FAN ON) SIGNAL

Check FAN ON/OFF signal. Refer to [HAC-15, "CONSULT-III Function \(BCM\)"](#)

**BLOWER CONTROL DIAL ON : FAN ON SIG ON**  
**BLOWER CONTROL DIAL OFF : FAN ON SIG OFF**

Is the inspection result normal?

- YES >> GO TO 7.  
NO >> GO TO 5.

# MAGNET CLUTCH

< COMPONENT DIAGNOSIS >

[MANUAL AIR CONDITIONER]

## 5. CHECK CIRCUIT CONTINUITY BETWEEN BCM AND FRONT AIR CONTROL

1. Turn ignition switch OFF.
2. Disconnect BCM connector and front air control connector.
3. Check continuity between BCM harness connector M18 (A) terminal 28 and front air control harness connector M49 (B) terminal 18.

A		B		Continuity
Connector	Terminal	Connector	Terminal	
BCM: M18	28	Front air control: M49	18	Yes

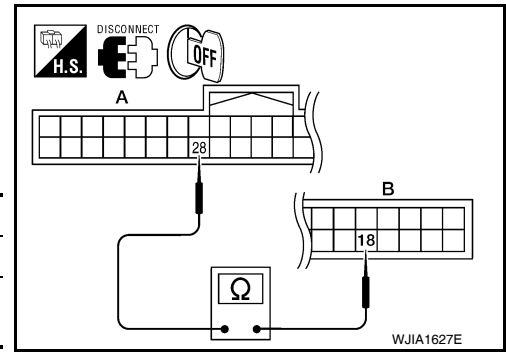

Is the inspection result normal?

- YES >> GO TO 6.  
NO >> Repair harness or connector.

## 6. CHECK VOLTAGE FOR FRONT AIR CONTROL (FAN ON SIGNAL)

1. Reconnect BCM connector and front air control connector.
2. Turn ignition switch ON.
3. Turn A/C switch ON.
4. Check voltage between front air control harness connector M49 terminal 18 and ground.

Terminals		Condition	Voltage (Approx.)
(+)	(-)		
Front air control connector	Terminal No.		
M49	18	A/C switch: ON Blower motor operates	0V
		A/C switch: OFF	Battery voltage

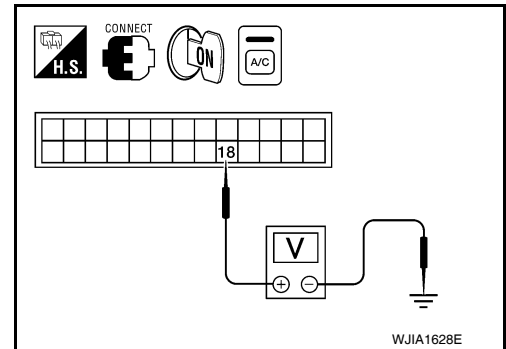

Is the inspection result normal?

- YES >> Replace BCM. Refer to [BCS-53, "Removal and Installation"](#).  
NO-1 >> If the voltage is approx. 5V when blower motor is ON, replace front air control. Refer to [VTL-7, "Removal and Installation"](#).  
NO-2 >> If the voltage is approx. 0V when blower motor is OFF, replace BCM. Refer to [BCS-53, "Removal and Installation"](#).

## 7. CHECK CAN COMMUNICATION

Check CAN communication. Refer to [LAN-14, "Trouble Diagnosis Flow Chart"](#).

Is the inspection result normal?

- YES >> Inspection End.  
NO >> Repair or replace malfunctioning part(s).

## 8. CHECK VOLTAGE FOR FRONT AIR CONTROL (A/C COMPRESSOR ON SIGNAL)

1. Reconnect BCM connector and front air control connector.
2. Turn ignition switch ON.
3. Check voltage between front air control harness connector M49 terminal 10 and ground.

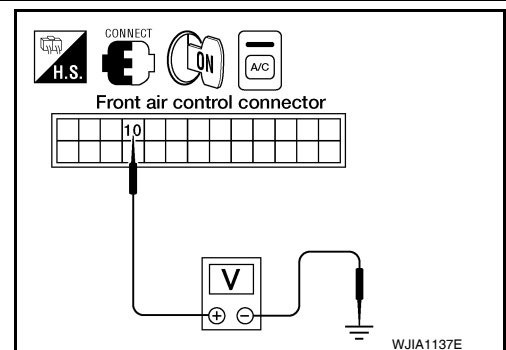

# MAGNET CLUTCH

< COMPONENT DIAGNOSIS >

[MANUAL AIR CONDITIONER]

Terminals		Condition	Voltage (Approx.)
(+)	(-)		
Front air control connector	Terminal No.		
M49	10	Ground	0V
		A/C switch: OFF	Battery voltage

Is the inspection result normal?

YES >> GO TO 9.

NO-1 >> If the voltage is approx. 5V when A/C switch is ON, replace front air control. Refer to [VTL-7, "Removal and Installation"](#).

NO-2 >> If the voltage is approx. 0V when A/C switch is OFF, replace BCM. Refer to [BCS-53, "Removal and Installation"](#).

## 9. CHECK CIRCUIT CONTINUITY BETWEEN BCM AND FRONT AIR CONTROL

1. Disconnect BCM connector and front air control connector.
2. Check continuity between BCM harness connector M18 (A) terminal 27 and front air control harness connector M49 (B) terminal 10.

**27 - 10 : Continuity should exist.**

Is the inspection result normal?

YES >> GO TO 10.

NO >> Repair harness or connector.

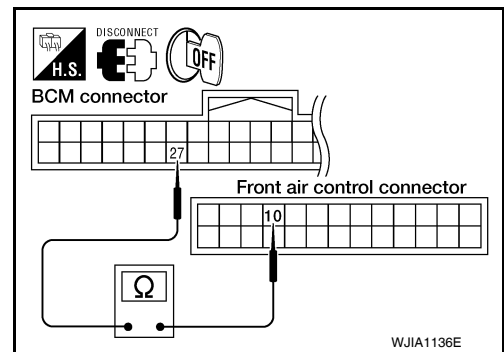

## 10. CHECK INTAKE SENSOR CIRCUITS

Check intake sensor. Refer to [VTL-8, "Removal and Installation"](#).

Is the inspection result normal?

YES >> GO TO 11.

NO >> Replace intake sensor. Refer to [VTL-8, "Removal and Installation"](#).

## 11. CHECK CAN COMMUNICATION

Check CAN communication. Refer to [LAN-14, "Trouble Diagnosis Flow Chart"](#).

Is the inspection result normal?

YES >> Replace BCM. Refer to [BCS-53, "Removal and Installation"](#).

NO >> Repair or replace malfunctioning part(s).

## 12. CHECK MAGNET CLUTCH CIRCUIT

Check for operation sound when applying battery voltage to terminal.

Is the inspection result normal?

YES >> GO TO 13.

NO >> Replace magnet clutch. Refer to [HA-31, "Removal and Installation for Compressor Clutch"](#).

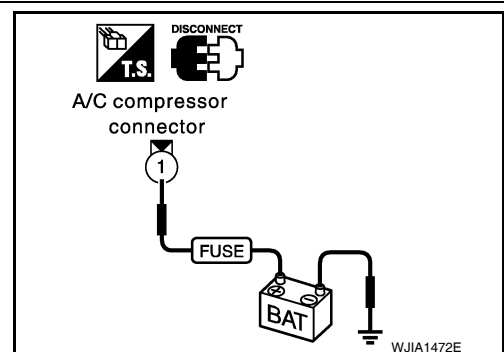

## 13. CHECK CIRCUIT CONTINUITY BETWEEN IPDM E/R AND A/C COMPRESSOR

# MAGNET CLUTCH

[MANUAL AIR CONDITIONER]

## < COMPONENT DIAGNOSIS >

1. Turn ignition switch OFF.
2. Disconnect IPDM E/R connector and A/C compressor (magnet clutch) connector.
3. Check continuity between IPDM E/R harness connector E119 terminal 11 and A/C compressor harness connector F3 terminal 1.

**11 - 1 : Continuity should exist.**

Is the inspection result normal?

- YES >> Replace IPDM E/R. Refer to [PCS-34, "Removal and Installation of IPDM E/R"](#).
- NO >> Repair harness or connector.

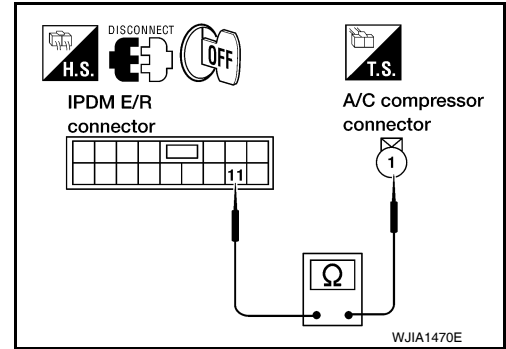

## INTAKE SENSOR

### System Description

INFOID:000000003081789

### COMPONENT DESCRIPTION

#### Intake Sensor

The intake sensor is located on top of the heater and cooling unit assembly next to the A/C evaporator cover. It converts temperature of air after it passes through the evaporator into a resistance value which is then input to the front air control.

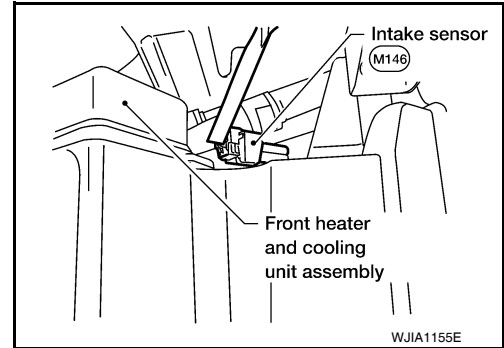

### Intake Sensor Diagnosis Procedure

INFOID:000000003081790

#### DIAGNOSTIC PROCEDURE FOR INTAKE SENSOR

SYMPTOM: Intake sensor circuit is open or shorted.

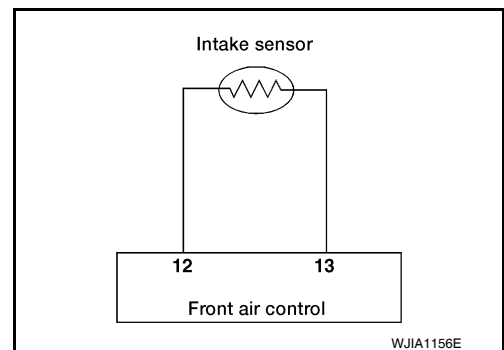

#### 1. CHECK VOLTAGE BETWEEN INTAKE SENSOR AND GROUND

1. Disconnect intake sensor connector.
2. Turn ignition switch ON.
3. Check voltage between intake sensor harness connector M146 terminal 2 and ground.

**2 - Ground : Approx. 5V**

Is the inspection result normal?

- YES >> GO TO 2.  
NO >> GO TO 4.

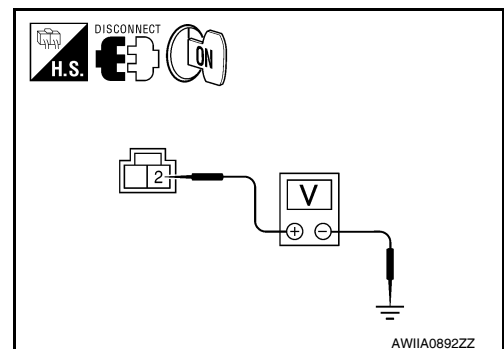

#### 2. CHECK CIRCUIT CONTINUITY BETWEEN INTAKE SENSOR AND FRONT AIR CONTROL

1. Turn ignition switch OFF.
2. Disconnect front air control connector.
3. Check continuity between intake sensor harness connector M146 (A) terminal 1 and front air control harness connector M49 (B) terminal 13.

**1 - 13 : Continuity should exist.**

Is the inspection result normal?

- YES >> GO TO 3.  
NO >> Repair harness or connector.

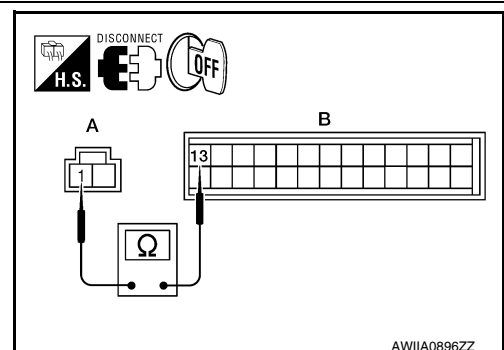

A  
B  
C  
D  
E  
F  
G  
H  
J  
K  
L  
M  
N  
O  
P

HAC

# INTAKE SENSOR

< COMPONENT DIAGNOSIS >

[MANUAL AIR CONDITIONER]

## 3. CHECK INTAKE SENSOR

Refer to [HAC-40, "Intake Sensor Component Inspection"](#).

Is the inspection result normal?

- YES >> Replace front air control. Refer to [VTL-7, "Removal and Installation"](#).
- NO >> Replace intake sensor. Refer to [VTL-8, "Removal and Installation"](#).

## 4. CHECK CIRCUIT CONTINUITY BETWEEN INTAKE SENSOR AND FRONT AIR CONTROL

1. Turn ignition switch OFF.
2. Disconnect front air control connector.
3. Check continuity between intake sensor harness connector M146 (B) terminal 2 and front air control harness connector M49 (A) terminal 12.

**2 - 12** : Continuity should exist.

4. Check continuity between intake sensor harness connector M146 (A) terminal 2 and ground.

**2 - Ground** : Continuity should not exist.

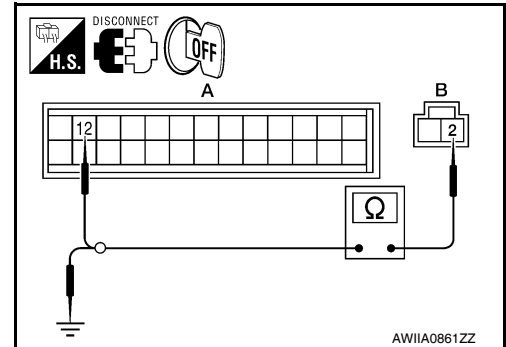

Is the inspection result normal?

- YES >> Replace front air control. Refer to [VTL-7, "Removal and Installation"](#).
- NO >> Repair harness or connector.

## Intake Sensor Component Inspection

INFOID:000000003081791

### COMPONENT INSPECTION

Intake Sensor

After disconnecting intake sensor connector, measure resistance between terminals 1 and 2 at sensor harness side, using the table below.

Temperature °C (°F)	Resistance kΩ
-15 (5)	209.0
-10 (14)	160.0
-5 (23)	123.0
0 (32)	95.8
5 (41)	74.9
10 (50)	58.9
15 (59)	46.7
20 (68)	37.3
25 (77)	30.0
30 (86)	24.2
35 (95)	19.7
40 (104)	16.1
45 (113)	13.2

If NG, replace intake sensor. Refer to [VTL-8, "Removal and Installation"](#).

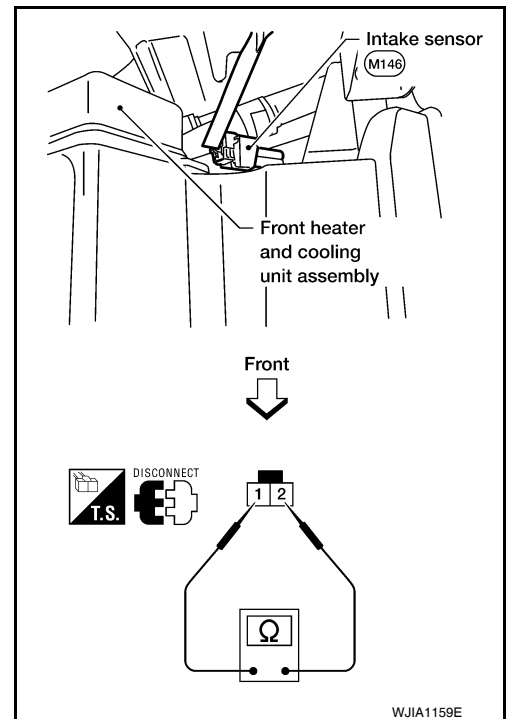



# POWER SUPPLY AND GROUND CIRCUIT FOR CONTROLLER

< COMPONENT DIAGNOSIS >

[MANUAL AIR CONDITIONER]

## POWER SUPPLY AND GROUND CIRCUIT FOR CONTROLLER

### Component Description

INFOID:000000003081792

#### COMPONENT DESCRIPTION

##### Front Air Control

The front air control has a built-in microcomputer which processes information sent from various sensors needed for air conditioner operation. The air mix door motor, mode door motor, intake door motor, defroster door motor, blower motor and compressor are then controlled.

The front air control is unitized with control mechanisms. When the various switches and temperature dials are operated, data is input to the front air control.

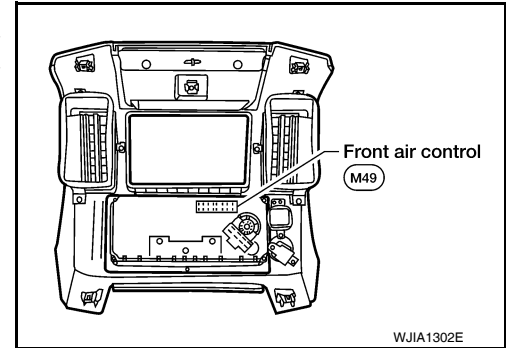

##### Potential Temperature Control (PTC)

The PTC is built into the front air control. It can be set from cold to hot or any intermediate position by rotating the temperature dial.

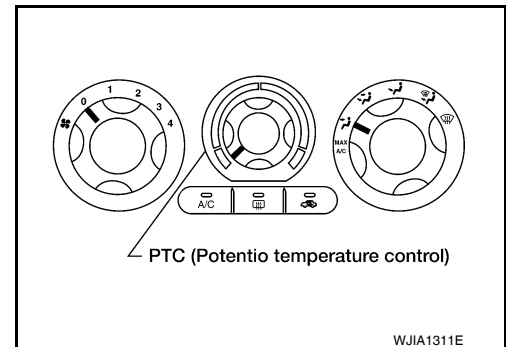

### Front Air Control Component Function Check

INFOID:000000003081793

SYMPTOM: A/C system does not come on.

#### INSPECTION FLOW

#### 1. CONFIRM SYMPTOM BY PERFORMING OPERATIONAL CHECK

1. Turn blower control dial to position 1-4, then press A/C switch.
2. Confirm that the compressor clutch engages (sound or visual inspection).

##### Can a symptom be duplicated?

- YES >> GO TO 3.
- NO >> GO TO 2.

#### 2. PERFORM COMPLETE OPERATIONAL CHECK

Perform a complete operational check and check for any symptoms. Refer to [HAC-4, "Operational Check"](#).

##### Can a symptom be duplicated?

- YES >> Refer to [HAC-52, "Symptom Matrix Chart"](#).
- NO >> System OK.

#### 3. CHECK FOR SERVICE BULLETINS

Check for any service bulletins.

>> GO TO 4.

#### 4. CHECK POWER AND GROUND CIRCUIT

Check main power supply and ground circuit. Refer to [HAC-42, "Front Air Control Power and Ground Diagnosis Procedure"](#).

# POWER SUPPLY AND GROUND CIRCUIT FOR CONTROLLER

[MANUAL AIR CONDITIONER]

< COMPONENT DIAGNOSIS >

Is the inspection result normal?

YES >> System OK.

NO >> Replace front air control. Refer to [VTL-7, "Removal and Installation"](#).

## Front Air Control Power and Ground Diagnosis Procedure

INFOID:000000003081794

### DIAGNOSTIC PROCEDURE FOR A/C SYSTEM

SYMPTOM: A/C system does not come on.

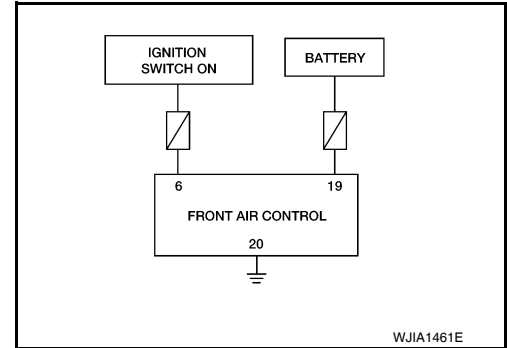

## 1. CHECK POWER SUPPLY CIRCUITS FOR FRONT AIR CONTROL

1. Turn ignition switch OFF.
2. Disconnect front air control connector.
3. Turn ignition switch ON.
4. Check voltage between front air control harness connector M49 terminals 6 and 19, and ground.

Terminals		Ignition switch position			
(+)		(-)	OFF	ACC	ON
Front air control connector	Terminal No.				
M49	6	Ground	Approx. 0V	Approx. 0V	Battery voltage
M49	19		Battery voltage	Battery voltage	Battery voltage

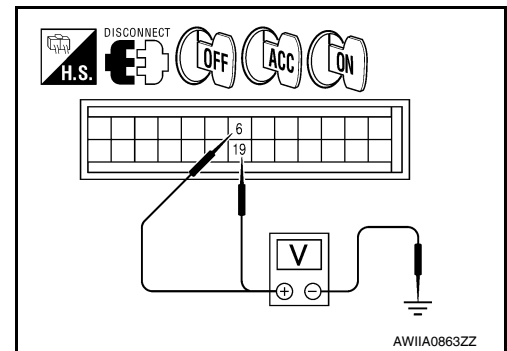

Is the inspection result normal?

YES >> GO TO 2.

NO >> Check 10A fuses [Nos. 8 and 19, located in the fuse block (J/B)]. Refer to [PG-69, "Terminal Arrangement"](#).

- If fuses are OK, check harness for open circuit. Repair or replace as necessary.
- If fuses are NG, replace fuse and check harness for short circuit. Repair or replace as necessary.

## 2. CHECK GROUND CIRCUIT FOR FRONT AIR CONTROL

1. Turn ignition switch OFF.
2. Check continuity between front air control harness connector M49 terminal 20 and ground.

**20 - Ground : Continuity should exist.**

Is the inspection result normal?

YES >> Replace front air control. Refer to [VTL-7, "Removal and Installation"](#).

NO >> Repair harness or connector.

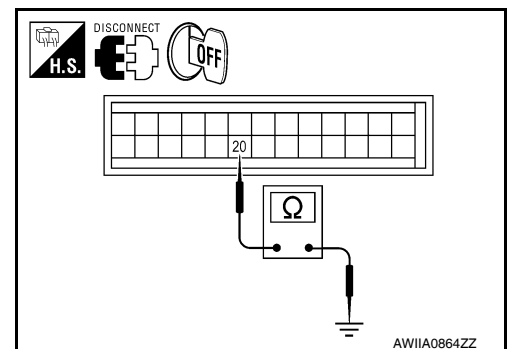

# AIR CONDITIONER CONTROL

< ECU DIAGNOSIS >

[MANUAL AIR CONDITIONER]

## ECU DIAGNOSIS

### AIR CONDITIONER CONTROL

#### Front Air Control Terminals Reference Values

INFOID:000000003081797

Measure voltage between each terminal and ground by following Terminals and Reference Values for front air control.

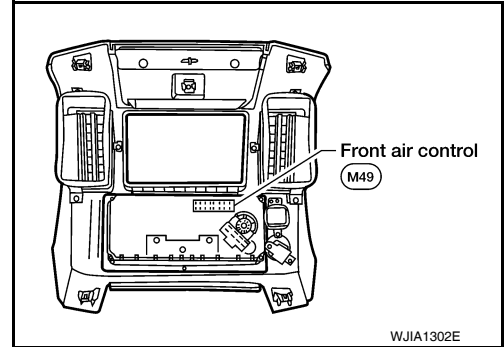

#### FRONT AIR CONTROL HARNESS CONNECTOR TERMINAL LAYOUT

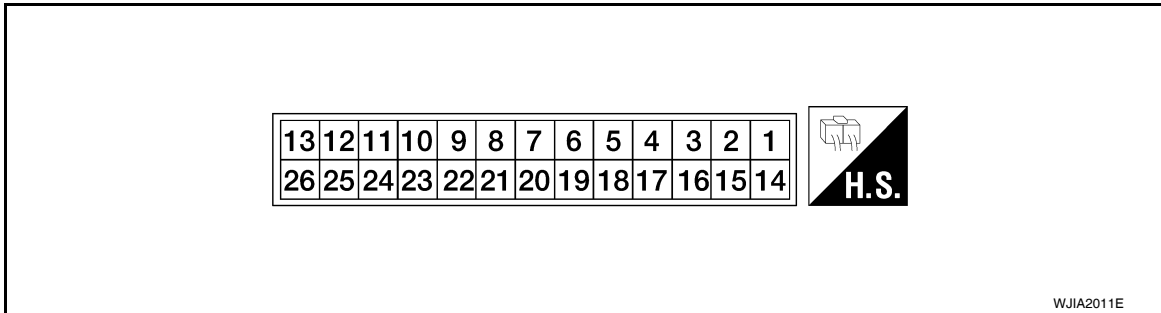

#### TERMINALS AND REFERENCE VALUES FOR FRONT AIR CONTROL

Terminal No.	Wire color	Item	Ignition switch	Condition	Voltage (V) (Approx.)
1	BR	Mode door motor CW	ON	Clockwise rotation	Battery voltage
2	W/G	Air mix door motor (Driver) CW	ON	Clockwise rotation	Battery voltage
3	GR	Air mix door motor (Driver) CCW	ON	Counterclockwise rotation	Battery voltage
4	Y	Intake door motor CW	ON	Clockwise rotation	Battery voltage
5	O	Intake door motor CCW	ON	Counterclockwise rotation	Battery voltage
6	W/G	Power supply for IGN	ON	-	Battery voltage
8	G	Illumination +	ON	Park lamps ON	Battery voltage
9	BR	Illumination -	-	Park lamps ON	<p>PIIA2344E</p>
10	W	Compressor ON signal	ON	A/C switch OFF	5V
			ON	A/C switch ON	0V
11	Y	Rear defrost request	ON	-	Battery voltage
12	L	Intake sensor	ON	-	0 - 5V
13	V	Sensor ground	ON	-	0 - 5V
14	R	Mode door motor CCW	ON	Counterclockwise rotation	Battery voltage

# AIR CONDITIONER CONTROL

< ECU DIAGNOSIS >

[MANUAL AIR CONDITIONER]

Terminal No.	Wire color	Item	Ignition switch	Condition	Voltage (V) (Approx.)
18	BR	Front blower monitor	ON	Front blower motor OFF	Battery voltage
				Front blower motor ON	0V
19	R/Y	Power supply for BAT	-	-	Battery voltage
20	B	Ground	-	-	0V
21	V	Mode door motor feedback	ON	-	0 - 5V
22	SB	Air mix door motor (Front) feedback	ON	-	0 - 5V
23	G	Power supply for mode door motor and air mix door motor (Front) PBR	ON	-	5V
25	R	Rear defroster request	ON	-	Battery voltage
26	P	Ground for mode door motor and air mix door motor (Front) PBR	ON	-	0V

# AIR CONDITIONER CONTROL

[MANUAL AIR CONDITIONER]

< ECU DIAGNOSIS >

## Wiring Diagram

INFOID:000000003081798

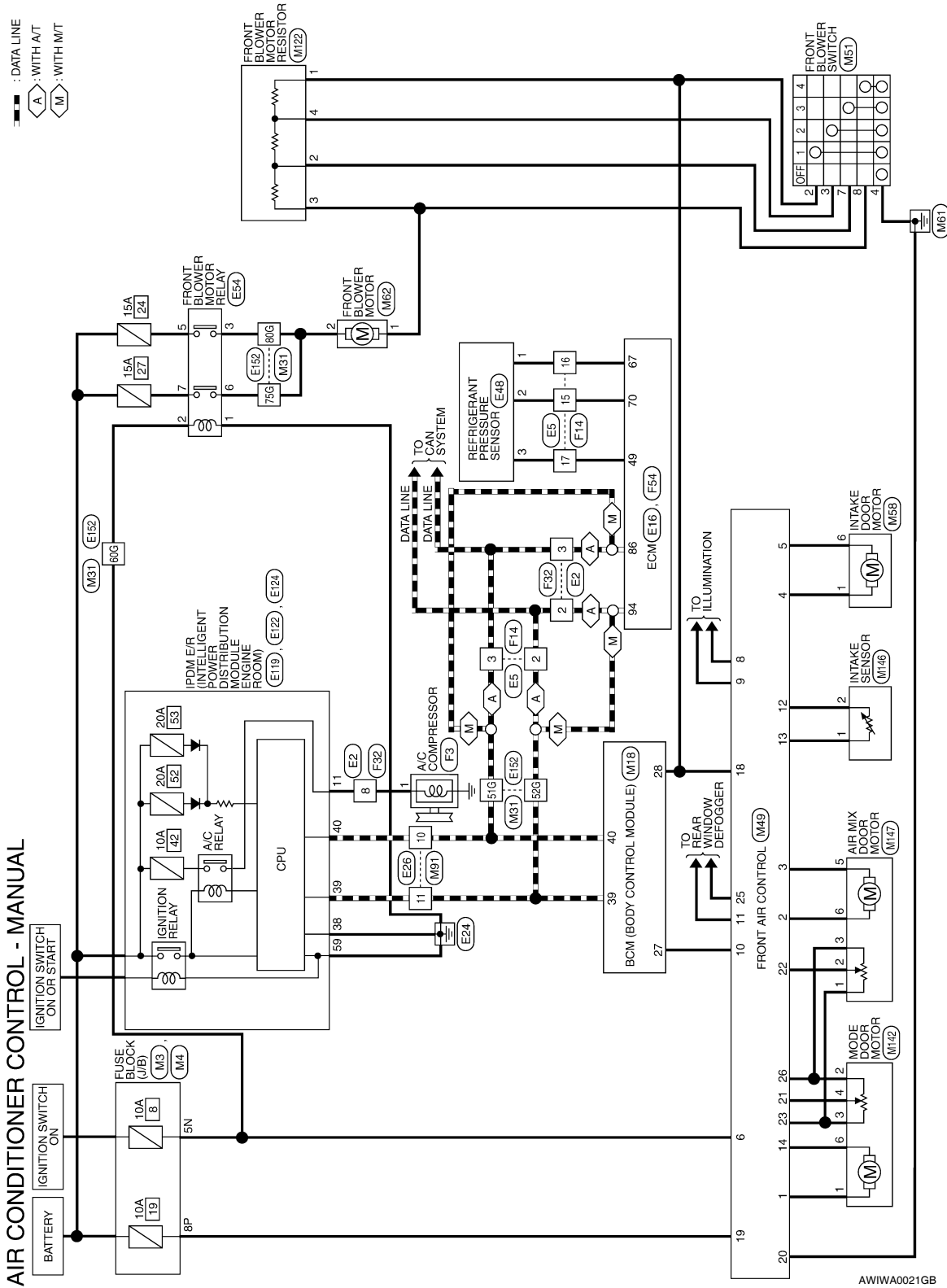

AWIWA0021GB

A  
B  
C  
D  
E  
F  
G  
H  
I  
J  
K  
L  
M  
N  
O  
P

HAC

## AIR CONDITIONER CONTROL CONNECTORS - MANUAL

Connector No.	M3
Connector Name	FUSE BLOCK (J/B)
Connector Color	WHITE

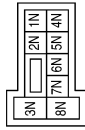

Connector No.	M4
Connector Name	FUSE BLOCK (J/B)
Connector Color	WHITE



Connector No.	M18
Connector Name	BCM (BODY CONTROL MODULE)
Connector Color	WHITE



Terminal No.	Color of Wire	Signal Name
5N	W/G	-

Terminal No.	Color of Wire	Signal Name
8P	R/Y	-

Terminal No.	Color of Wire	Signal Name
27	W	AIRCON_SW
28	R	BLOWER FAN SW
39	L	CAN-H
40	P	CAN-L

Connector No.	M31
Connector Name	WIRE TO WIRE
Connector Color	WHITE

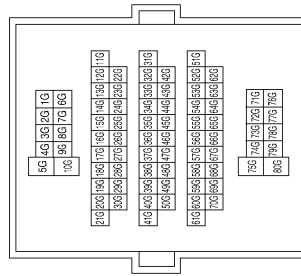

Terminal No.	Color of Wire	Signal Name
51G	P	-
52G	L	-
60G	W/G	-
75G	W/G	-
80G	W/G	-

# AIR CONDITIONER CONTROL

[MANUAL AIR CONDITIONER]

< ECU DIAGNOSIS >

Terminal No.	Color of Wire	Signal Name
24	-	-
25	R	RR DEF STATUS
26	P	MODE (GND)

Terminal No.	Color of Wire	Signal Name
8	-	-
9	-	-
10	W	A/C_REQUEST
11	Y	REAR DEFROST REQUEST
12	L	INTAKE SENSOR
13	V	SENS RETURN
14	R	MODE CCW
15	-	-
16	-	-
17	-	-
18	BR	RF BLOWER MONITOR
19	R/Y	BAT
20	B	GND
21	V	MODE FEED BACK
22	SB	BLEND FEED BACK
23	G	V REF ACTR (5V)

Connector No.	M49
Connector Name	FRONT AIR CONTROL
Connector Color	BLACK

13	12	11	10	9	8	7	6	5	4	3	2	1
26	25	24	23	22	21	20	19	18	17	16	15	14



Terminal No.	Color of Wire	Signal Name
1	BR	MODE CW
2	W/G	BLEND DR CW
3	GR	BLEND DR CCW
4	Y	RECIRC DOOR CW
5	O	RECIRC DOOR CCW
6	W/G	IGN
7	-	-

Connector No.	M62
Connector Name	FRONT BLOWER MOTOR
Connector Color	BLACK



Terminal No.	Color of Wire	Signal Name
1	L	-
2	W/G	-

Connector No.	M58
Connector Name	INTAKE DOOR MOTOR
Connector Color	BLACK

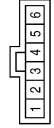

Terminal No.	Color of Wire	Signal Name
1	Y	-
6	O	-

Connector No.	M51
Connector Name	FRONT BLOWER SWITCH
Connector Color	WHITE



Terminal No.	Color of Wire	Signal Name
2	BR	-
3	SB	-
4	B	-
7	Y	-
8	W	-

AW1IA0684GB

A  
B  
C  
D  
E  
F  
G  
H  
HAC  
J  
K  
L  
M  
N  
O  
P

# AIR CONDITIONER CONTROL

< ECU DIAGNOSIS >

[MANUAL AIR CONDITIONER]

Connector No.	M142
Connector Name	MODE DOOR MOTOR
Connector Color	BLACK

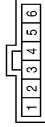

Terminal No.	Color of Wire	Signal Name
1	BR	-
2	P	-
3	G	-
4	V	-
6	R	-

Connector No.	M122
Connector Name	FRONT BLOWER MOTOR RESISTOR
Connector Color	WHITE

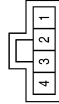

Terminal No.	Color of Wire	Signal Name
1	R	-
2	Y	-
3	L	-
4	SB	-

Connector No.	M91
Connector Name	WIRE TO WIRE
Connector Color	WHITE

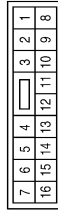

Terminal No.	Color of Wire	Signal Name
10	P	-
11	L	-

Connector No.	E2
Connector Name	WIRE TO WIRE
Connector Color	WHITE

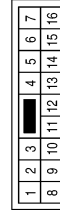

Terminal No.	Color of Wire	Signal Name
2	L	-
3	P	-
8	Y	-

Connector No.	M147
Connector Name	AIR MIX DOOR MOTOR
Connector Color	BLACK



Terminal No.	Color of Wire	Signal Name
1	Y	-
2	SB	-
3	P	-
5	GR	-
6	W	-

Connector No.	M146
Connector Name	INTAKE SENSOR
Connector Color	WHITE



Terminal No.	Color of Wire	Signal Name
1	V	-
2	L	-

AWIIA0685GB



# AIR CONDITIONER CONTROL

[MANUAL AIR CONDITIONER]

< ECU DIAGNOSIS >

Connector No.	E26
Connector Name	WIRE TO WIRE
Connector Color	WHITE

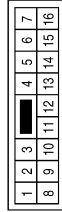

Terminal No.	Color of Wire	Signal Name
10	P	-
11	L	-

Connector No.	E16
Connector Name	ECM
Connector Color	BLACK

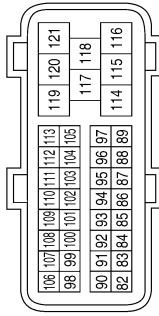

Terminal No.	Color of Wire	Signal Name
86	P	CAN-L
94	L	CAN-H

Connector No.	E5
Connector Name	WIRE TO WIRE
Connector Color	WHITE

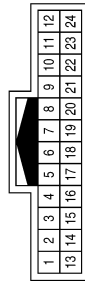

Terminal No.	Color of Wire	Signal Name
2	L	-
3	P	-
15	BR	-
16	B	-
17	P	-

Connector No.	E119
Connector Name	IPDM E/R (INTELLIGENT POWER DISTRIBUTION MODULE ENGINE ROOM)
Connector Color	WHITE



Terminal No.	Color of Wire	Signal Name
11	Y	A/C_COMPRESSOR

Connector No.	E54
Connector Name	FRONT BLOWER MOTOR RELAY
Connector Color	BROWN



Terminal No.	Color of Wire	Signal Name
1	W/G	-
2	B	-
3	W/G	-
5	L	-
6	W/G	-
7	GR	-

Connector No.	E48
Connector Name	REFRIGERANT PRESSURE SENSOR
Connector Color	BLACK



Terminal No.	Color of Wire	Signal Name
1	B	GND
2	BR	SIGNAL
3	P	POWER_SUPPLY

AW1IA0686GB

A  
B  
C  
D  
E  
F  
G  
H  
HAC  
J  
K  
L  
M  
N  
O  
P

# AIR CONDITIONER CONTROL

< ECU DIAGNOSIS >

[MANUAL AIR CONDITIONER]

Connector No.	E152
Connector Name	WIRE TO WIRE
Connector Color	WHITE

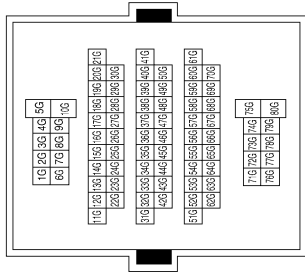

# AIR CONDITIONER CONTROL

< ECU DIAGNOSIS >

[MANUAL AIR CONDITIONER]

Connector No.	F54
Connector Name	ECM
Connector Color	BLACK



63	64	65	66	67	68	69	70	71	72	73	74	75	76	77	78	79	80	81	2	1
44	45	46	47	48	49	50	51	52	53	54	55	56	57	58	59	60	61	62	3	
25	26	27	28	29	30	31	32	33	34	35	36	37	38	39	40	41	42	43		
6	7	8	9	10	11	12	13	14	15	16	17	18	19	20	21	22	23	24	5	4

Terminal No.	Color of Wire	Signal Name
49	P	AVCC(PDPRES)
67	B	GND-A
70	BR	PDPRES

A  
B  
C  
D  
E  
F  
G  
H  
HAC  
J  
K  
L  
M  
N  
O  
P

AWIIA0688GB

## SYMPTOM DIAGNOSIS

### AIR CONDITIONER CONTROL

#### Symptom Matrix Chart

INFOID:000000003081799

#### SYMPTOM TABLE

Symptom	Reference Page	
A/C system does not come on.	Go to Trouble Diagnosis Procedure for A/C System.	<a href="#">HAC-41</a>
Air outlet does not change.	Go to Trouble Diagnosis Procedure for Mode Door Motor.	<a href="#">HAC-16</a>
Mode door motor is malfunctioning.		
Discharge air temperature does not change.	Go to Trouble Diagnosis Procedure for Air Mix Door Motor.	<a href="#">HAC-21</a>
Air mix door motor is malfunctioning.		
Intake door does not change.	Go to Trouble Diagnosis Procedure for Intake Door Motor.	<a href="#">HAC-24</a>
Intake door motor is malfunctioning.		
Front blower motor operation is malfunctioning.	Go to Trouble Diagnosis Procedure for Front Blower Motor.	<a href="#">HAC-27</a>
Magnet clutch does not engage.	Go to Trouble Diagnosis Procedure for Magnet Clutch.	<a href="#">HAC-34</a>
Insufficient cooling	Go to Trouble Diagnosis Procedure for Insufficient Cooling.	<a href="#">HAC-53</a>
Insufficient heating	Go to Trouble Diagnosis Procedure for Insufficient Heating.	<a href="#">HAC-61</a>
Noise	Go to Trouble Diagnosis Procedure for Noise.	<a href="#">HAC-63</a>

**INSUFFICIENT COOLING****Component Function Check**

INFOID:000000003081800

SYMPTOM: Insufficient cooling

**INSPECTION FLOW****1. CONFIRM SYMPTOM BY PERFORMING OPERATIONAL CHECK - TEMPERATURE DECREASE**

1. Turn temperature control dial counterclockwise to maximum cold.
2. Check for cold air at discharge air outlets.

Can the symptom be duplicated?

- YES >> GO TO 3.  
NO >> GO TO 2.

**2. CHECK FOR ANY SYMPTOMS**Perform a complete operational check for any symptoms. Refer to [HAC-4, "Operational Check"](#).Does another symptom exist?

- YES >> Refer to [HAC-52, "Symptom Matrix Chart"](#).  
NO >> System OK.

**3. CHECK FOR SERVICE BULLETINS**

Check for any service bulletins.

&gt;&gt; GO TO 4.

**4. CHECK DRIVE BELTS**Check compressor belt tension. Refer to [EM-13, "Checking Drive Belts"](#).Is the inspection result normal?

- YES >> GO TO 5.  
NO >> Adjust or replace compressor belt. Refer to [EM-13, "Checking Drive Belts"](#).

**5. CHECK AIR MIX DOOR OPERATION**

Check and verify air mix door mechanism for smooth operation.

Does air mix door operate correctly?

- YES >> GO TO 6.  
NO >> Repair or replace air mix door control linkage.

**6. CHECK COOLING FAN MOTOR OPERATION**Check and verify cooling fan motor for smooth operation. Refer to [EC-401, "Component Inspection"](#).Does cooling fan motor operate correctly?

- YES >> GO TO 7.  
NO >> Check cooling fan motor. Refer to [EC-400, "Diagnosis Procedure"](#).

**7. CHECK RECOVERY/RECYCLING EQUIPMENT BEFORE USAGE**

Check recovery/recycling equipment before connecting to vehicle. Verify there is no pressure in the recovery/recycling equipment by checking the gauges. If pressure exists, recover refrigerant from equipment lines.

&gt;&gt; GO TO 8.

**8. CHECK REFRIGERANT PURITY**

1. Connect recovery/recycling equipment to vehicle.
2. Confirm refrigerant purity in supply tank using recovery/recycling and refrigerant identifier.

Is the inspection result normal?

- YES >> GO TO 9.  
NO >> Check contaminated refrigerant. Refer to [HA-4, "Contaminated Refrigerant"](#).

# INSUFFICIENT COOLING

< SYMPTOM DIAGNOSIS >

[MANUAL AIR CONDITIONER]

---

## 9. CHECK FOR EVAPORATOR FREEZE UP

---

Start engine and run A/C. Check for evaporator freeze up.

Does evaporator freeze up?

YES >> Perform diagnostic work flow. Refer to [HAC-54, "Diagnostic Work Flow"](#).

NO >> GO TO 10.

## 10. CHECK REFRIGERANT PRESSURE

---

Check refrigerant pressure with manifold gauge connected. Refer to [HAC-56, "Performance Chart"](#).

Is the inspection result normal?

YES >> Perform diagnostic work flow. Refer to [HAC-54, "Diagnostic Work Flow"](#).

NO >> GO TO 11.

## 11. CHECK AIR DUCTS

---

Check ducts for air leaks.

Is the inspection result normal?

YES >> System OK.

NO >> Repair air leaks.

Diagnostic Work Flow

INFOID:000000003081801

# INSUFFICIENT COOLING

< SYMPTOM DIAGNOSIS >

[MANUAL AIR CONDITIONER]

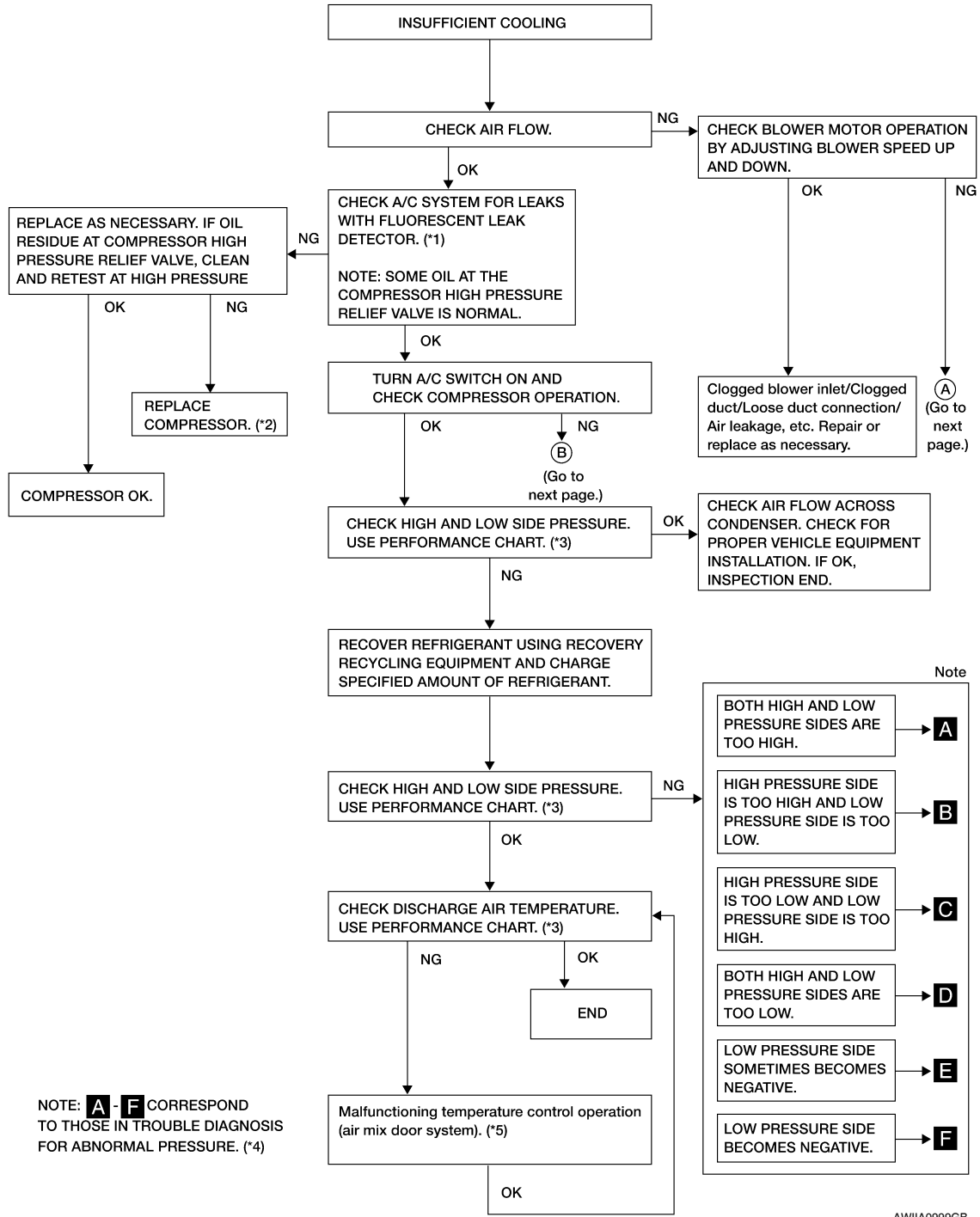

\*1 [HA-22. "Checking System for Leaks Using the Fluorescent Dye Leak Detector"](#)

\*2 [HA-30. "Removal and Installation for Compressor"](#)

\*3 [HAC-56. "Performance Chart"](#)

\*4 [HAC-57. "Trouble Diagnoses for Abnormal Pressure"](#)

\*5 [HAC-22. "Air Mix Door Motor Diagnosis Procedure"](#)

# INSUFFICIENT COOLING

< SYMPTOM DIAGNOSIS >

[MANUAL AIR CONDITIONER]

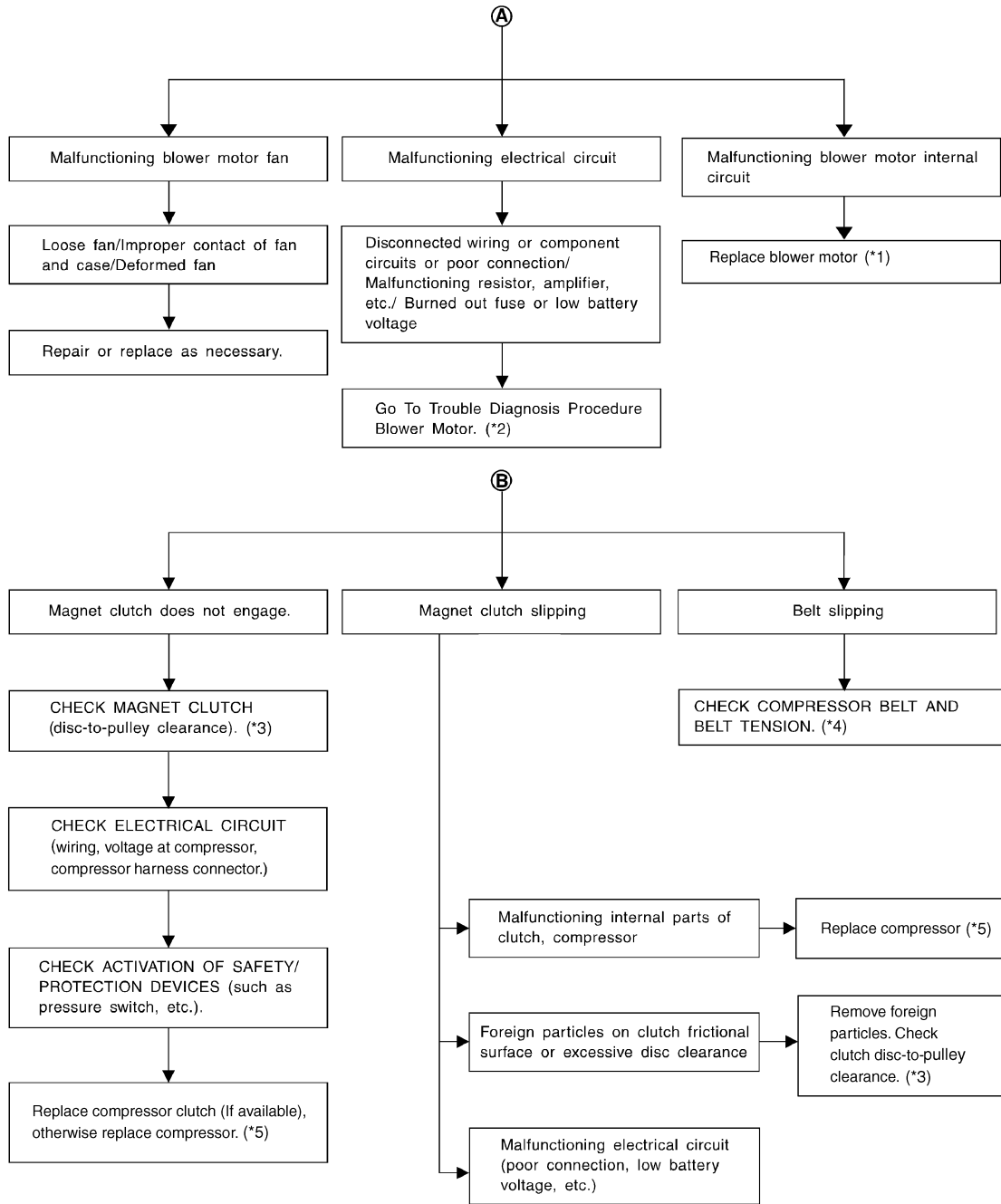

AWIA1000GB

\*1 [VTL-9. "Removal and Installation"](#)

\*2 [HAC-28. "Front Blower Motor Diagnosis Procedure"](#)

\*3 [HA-31. "Removal and Installation for Compressor Clutch"](#)

\*4 [EM-13. "Checking Drive Belts"](#)

\*5 [HA-30. "Removal and Installation for Compressor"](#)

## Performance Chart

INFOID:000000003081802

## TEST CONDITION

Testing must be performed as follows:



# INSUFFICIENT COOLING

< SYMPTOM DIAGNOSIS >

[MANUAL AIR CONDITIONER]

Vehicle location	Indoors or in the shade (in a well-ventilated place)
Doors	Closed
Door window	Open
Hood	Open
TEMP.	Max. COLD
Mode switch	(Ventilation) set
Recirculation (REC) switch	(Recirculation) set
Blower speed	Max. speed set
Engine speed	Idle speed

Operate the air conditioning system for 10 minutes before taking measurements.

## TEST READING

Recirculating-to-discharge Air Temperature Table

Inside air (Recirculating air) at blower assembly inlet		Discharge air temperature at center ventilator °C (°F)
Relative humidity %	Air temperature °C (°F)	
50 - 60	20 (68)	5.3 - 6.5 (42 - 44)
	25 (77)	9.7 - 11.5 (49 - 53)
	30 (86)	13.8 - 16.3 (57 - 61)
	35 (95)	18.0 - 21.2 (64 - 70)
	40 (104)	22.2 - 25.7 (72 - 78)
60 - 70	20 (68)	6.5 - 7.7 (44 - 46)
	25 (77)	11.5 - 13.3 (53 - 56)
	30 (86)	16.3 - 18.8 (61 - 66)
	35 (95)	21.2 - 24.0 (70 - 75)
	40 (104)	25.7 - 29.2 (78 - 85)

Ambient Air Temperature-to-operating Pressure Table

Ambient air		High-pressure (Discharge side) kPa (kg/cm <sup>2</sup> , psi)	Low-pressure (Suction side) kPa (kg/cm <sup>2</sup> , psi)
Relative humidity %	Air temperature °C (°F)		
50 - 70	20 (68)	680 - 840 (6.94 - 8.57, 98.6 - 121.8)	160 - 198 (1.63 - 2.02, 23.2 - 28.7)
	25 (77)	800 - 985 (8.16 - 10.05, 116.0 - 142.8)	198 - 245 (2.02 - 2.50, 28.7 - 35.5)
	30 (86)	940 - 1,150 (9.59 - 11.73, 136.3 - 166.8)	225 - 278 (2.30 - 2.84, 32.6 - 40.3)
	35 (95)	1,160 - 1,410 (11.83 - 14.38, 168.2 - 204.5)	273 - 335 (2.78 - 3.42, 39.6 - 48.6)
	40 (104)	1,325 - 1,620 (13.52 - 16.52, 192.1 - 234.9)	325 - 398 (3.32 - 4.06, 47.1 - 57.7)

## Trouble Diagnoses for Abnormal Pressure

INFOID:000000003081804

Whenever system's high and/or low side pressure is abnormal, diagnose using a manifold gauge. The marker above the gauge scale in the following tables indicates the standard (usual) pressure range. Since the stan-

# INSUFFICIENT COOLING

< SYMPTOM DIAGNOSIS >

[MANUAL AIR CONDITIONER]

Standard (usual) pressure, however, differs from vehicle to vehicle, refer to above table (Ambient air temperature-to-operating pressure table).

Both High- and Low-pressure Sides are Too High

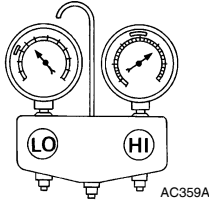
Gauge indication	Refrigerant cycle	Probable cause	Corrective action
<p><b>A</b> Both high- and low-pressure sides are too high.</p> 	Pressure is reduced soon after water is splashed on condenser.	Excessive refrigerant charge in refrigeration cycle	Reduce refrigerant until specified pressure is obtained.
	Air suction by cooling fan is insufficient.	Insufficient condenser cooling performance ↓ 1. Condenser fins are clogged. 2. Improper fan rotation of cooling fan	<ul style="list-style-type: none"> <li>• Clean condenser.</li> <li>• Check and repair cooling fan if necessary.</li> </ul>
	<ul style="list-style-type: none"> <li>• Low-pressure pipe is not cold.</li> <li>• When compressor is stopped high-pressure valve quickly drops by approximately 196 kPa (2 kg/cm<sup>2</sup>, 28 psi). It then decreases gradually thereafter.</li> </ul>	Poor heat exchange in condenser (After compressor operation stops, high-pressure decreases too slowly.) ↓ Air in refrigeration cycle	Evacuate and recharge system.
	Engine tends to overheat.	Engine cooling systems malfunction.	Check and repair engine cooling system.
	<ul style="list-style-type: none"> <li>• An area of the low-pressure pipe is colder than areas near the evaporator outlet.</li> <li>• Plates are sometimes covered with frost.</li> </ul>	<ul style="list-style-type: none"> <li>• Excessive liquid refrigerant on low-pressure side</li> <li>• Excessive refrigerant discharge flow</li> <li>• Expansion valve is open a little compared with the specification.</li> </ul> ↓ Improper expansion valve adjustment	Replace expansion valve.

High-pressure Side is Too High and Low-pressure Side is Too Low

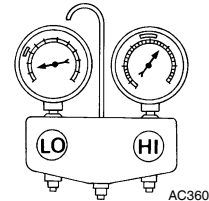
Gauge indication	Refrigerant cycle	Probable cause	Corrective action
<p><b>B</b> High-pressure side is too high and low-pressure side is too low.</p> 	Upper side of condenser and high-pressure side are hot, however, liquid tank is not so hot.	High-pressure tube or parts located between compressor and condenser are clogged or crushed.	<ul style="list-style-type: none"> <li>• Check and repair or replace malfunctioning parts.</li> <li>• Check oil for contamination.</li> </ul>

High-pressure Side is Too Low and Low-pressure Side is Too High

# INSUFFICIENT COOLING

< SYMPTOM DIAGNOSIS >

[MANUAL AIR CONDITIONER]

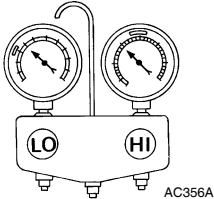
Gauge indication	Refrigerant cycle	Probable cause	Corrective action
<p><b>C</b> High-pressure side is too low and low-pressure side is too high.</p> 	<p>High- and low-pressure sides become equal soon after compressor operation stops.</p>	<p>Compressor pressure operation is improper. ↓ Damaged inside compressor packings.</p>	<p>Replace compressor.</p>
	<p>No temperature difference between high- and low-pressure sides.</p>	<p>Compressor pressure operation is improper. ↓ Damaged inside compressor packings.</p>	<p>Replace compressor.</p>

## Both High- and Low-pressure Sides are Too Low

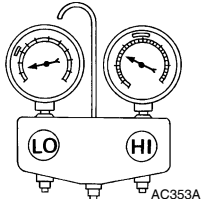
Gauge indication	Refrigerant cycle	Probable cause	Corrective action
<p><b>D</b> Both high- and low-pressure sides are too low.</p> 	<ul style="list-style-type: none"> <li>There is a big temperature difference between liquid tank outlet and inlet. Outlet temperature is extremely low.</li> <li>Liquid tank inlet and expansion valve are frosted.</li> </ul>	<p>Liquid tank inside is slightly clogged.</p>	<ul style="list-style-type: none"> <li>Replace liquid tank.</li> <li>Check oil for contamination.</li> </ul>
	<ul style="list-style-type: none"> <li>Temperature of expansion valve inlet is extremely low as compared with areas near liquid tank.</li> <li>Expansion valve inlet may be frosted.</li> <li>Temperature difference occurs somewhere in high-pressure side.</li> </ul>	<p>High-pressure pipe located between liquid tank and expansion valve is clogged.</p>	<ul style="list-style-type: none"> <li>Check and repair malfunctioning parts.</li> <li>Check oil for contamination.</li> </ul>
	<p>Expansion valve and liquid tank are warm or only cool when touched.</p>	<p>Low refrigerant charge. ↓ Leaking fittings or components.</p>	<p>Check refrigerant system for leaks. Refer to <a href="#">HA-24, "Checking of Refrigerant Leaks"</a>.</p>
	<p>There is a big temperature difference between expansion valve inlet and outlet while the valve itself is frosted.</p>	<p>Expansion valve closes a little compared with the specification. ↓ 1. Improper expansion valve adjustment. 2. Malfunctioning expansion valve. 3. Outlet and inlet may be clogged.</p>	<ul style="list-style-type: none"> <li>Remove foreign particles by using compressed air.</li> <li>Check oil for contamination.</li> </ul>
	<p>An area of the low-pressure pipe is colder than areas near the evaporator outlet.</p>	<p>Low-pressure pipe is clogged or crushed.</p>	<ul style="list-style-type: none"> <li>Check and repair malfunctioning parts.</li> <li>Check oil for contamination.</li> </ul>
	<p>Air flow volume is too low.</p>	<p>Evaporator is frozen.</p>	<ul style="list-style-type: none"> <li>Check intake sensor circuit. Refer to <a href="#">HAC-39, "Intake Sensor Diagnosis Procedure"</a>.</li> <li>Replace compressor.</li> <li>Repair evaporator fins.</li> <li>Replace evaporator.</li> <li>Refer to <a href="#">HAC-27, "Front Blower Motor Component Function Check"</a>.</li> </ul>

## Low-pressure Side Sometimes Becomes Negative

# INSUFFICIENT COOLING

< SYMPTOM DIAGNOSIS >

[MANUAL AIR CONDITIONER]

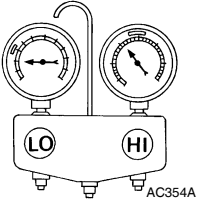
Gauge indication	Refrigerant cycle	Probable cause	Corrective action
<p><b>E</b> Low-pressure side sometimes becomes negative.</p>  <p style="text-align: right; font-size: small;">AC354A</p>	<ul style="list-style-type: none"> <li>• Air conditioning system does not function and does not cyclically cool the compartment air.</li> <li>• The system constantly functions for a certain period of time after compressor is stopped and restarted.</li> </ul>	<p>Refrigerant does not discharge cyclically.</p> <p>↓</p> <p>Moisture is frozen at expansion valve outlet and inlet.</p> <p>↓</p> <p>Water is mixed with refrigerant.</p>	<ul style="list-style-type: none"> <li>• Drain water from refrigerant or replace refrigerant.</li> <li>• Replace liquid tank.</li> </ul>

## Low-pressure Side Becomes Negative

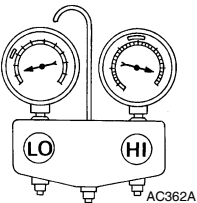
Gauge indication	Refrigerant cycle	Probable cause	Corrective action
<p><b>F</b> Low-pressure side becomes negative.</p>  <p style="text-align: right; font-size: small;">AC362A</p>	<p>Liquid tank or front/rear side of expansion valve's pipe is frosted or dewed.</p>	<p>High-pressure side is closed and refrigerant does not flow.</p> <p>↓</p> <p>Expansion valve or liquid tank is frosted.</p>	<p>Leave the system at rest until no frost is present. Start it again to check whether or not the malfunction is caused by water or foreign particles.</p> <ul style="list-style-type: none"> <li>• If water is the cause, initially cooling is okay. Then the water freezes causing a blockage. Drain water from refrigerant or replace refrigerant.</li> <li>• If due to foreign particles, remove expansion valve and remove the particles with dry and compressed air (not shop air).</li> <li>• If either of the above methods cannot correct the malfunction, replace expansion valve.</li> <li>• Replace liquid tank.</li> <li>• Check oil for contamination.</li> </ul>

**INSUFFICIENT HEATING****Component Function Check**

INFOID:000000003081805

SYMPTOM: Insufficient heating

**INSPECTION FLOW****1. CONFIRM SYMPTOM BY PERFORMING OPERATIONAL CHECK - TEMPERATURE INCREASE**

1. Rotate blower control dial clockwise.
2. Turn the temperature control dial clockwise to maximum heat.
3. Check for hot air at discharge air outlets.

Can the symptom be duplicated?

YES &gt;&gt; GO TO 2.

NO >> Perform complete operational check (front). Refer to [HAC-4, "Operational Check"](#).**2. CHECK FOR SERVICE BULLETINS**

Check for any service bulletins.

&gt;&gt; GO TO 3.

**3. CHECK ENGINE COOLING SYSTEM**

1. Check for proper engine coolant level.
2. Check hoses for leaks or kinks.
3. Check radiator cap. Refer to [CO-17, "Checking Radiator"](#).
4. Check for air in cooling system.

&gt;&gt; GO TO 4.

**4. CHECK AIR MIX DOOR OPERATION**

Check the operation of the air mix door.

Is the inspection result normal?

YES &gt;&gt; GO TO 5.

NO >> Check the air mix door motor circuit. Refer to [HAC-21, "Air Mix Door Motor Component Function Check"](#).**5. CHECK AIR DUCTS**

Check for disconnected or leaking air ducts.

Is the inspection result normal?

YES &gt;&gt; GO TO 6.

NO &gt;&gt; Repair all disconnected or leaking air ducts.

**6. CHECK HEATER HOSE TEMPERATURES**

1. Start engine and warm it up to normal operating temperature.
2. Touch both the inlet and outlet heater hoses.

Is the inspection result normal?

YES &gt;&gt; Hot inlet hose and a warm outlet hose: GO TO 7.

NO &gt;&gt; Both hoses warm: GO TO 8.

**7. CHECK ENGINE COOLANT SYSTEM**Check engine coolant temperature sensor. Refer to [EC-126, "Component Inspection"](#).Is the inspection result normal?

YES &gt;&gt; System OK.

NO &gt;&gt; Repair or replace as necessary. Retest.

**8. CHECK HEATER HOSES**

Check heater hoses for proper installation.

Is the inspection result normal?

## INSUFFICIENT HEATING

[MANUAL AIR CONDITIONER]

### < SYMPTOM DIAGNOSIS >

---

YES >> System OK.

- NO >> 1. Back flush heater core.  
2. Drain the water from the system.  
3. Refill system with new engine coolant. Refer to [CO-11. "Changing Engine Coolant"](#).  
4. GO TO 9 to retest.

### 9. CHECK HEATER HOSE TEMPERATURES

---

1. Start engine and warm it up to normal operating temperature.
2. Touch both the inlet and outlet heater hoses.

#### Is the inspection result normal?

YES >> System OK.

NO >> Replace heater core. Refer to [VTL-15. "Removal and Installation"](#).

## NOISE

### Component Function Check

INFOID:000000003081806

SYMPTOM: Noise

#### INSPECTION FLOW

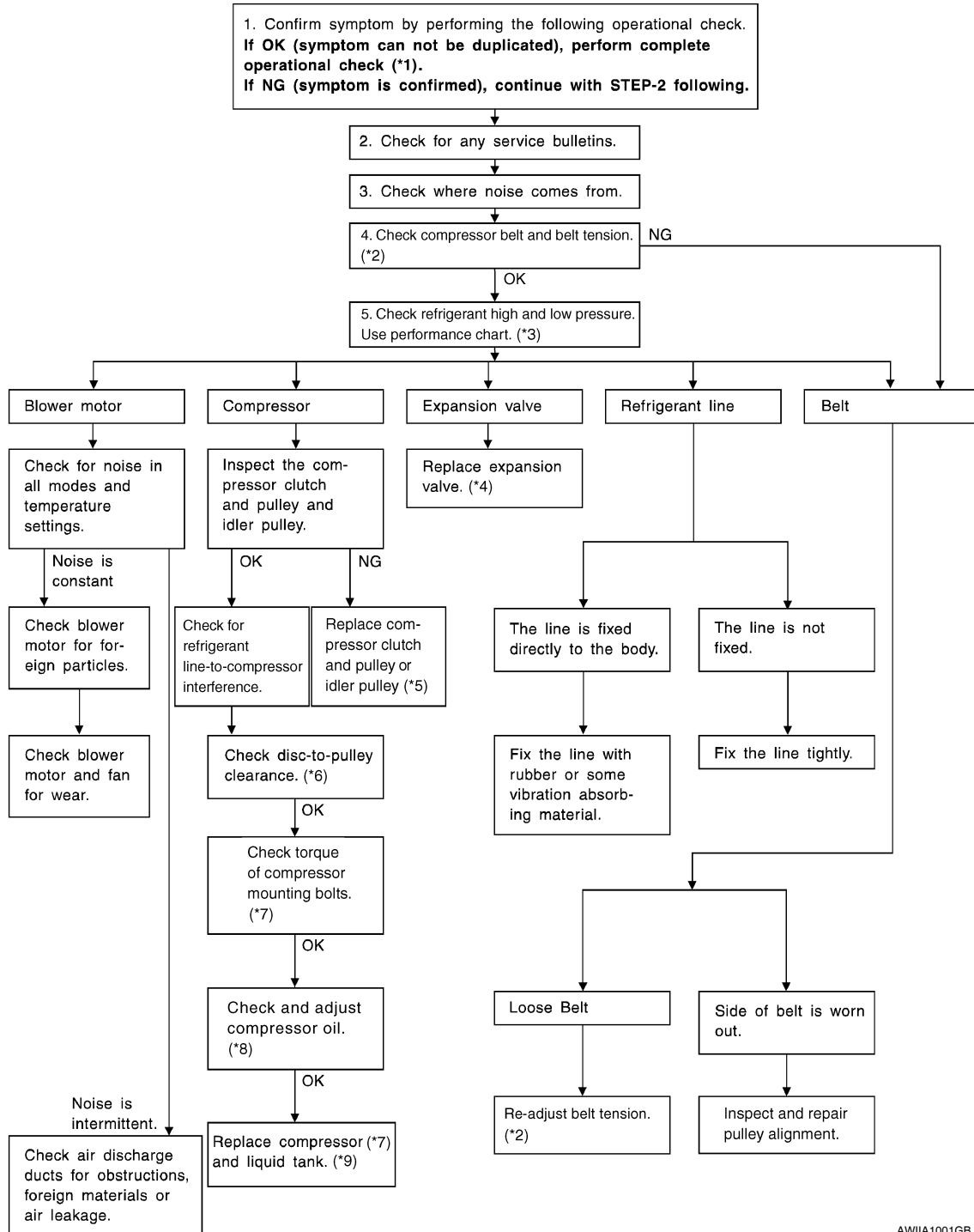

AWIA1001GB

\*1 [HAC-4, "Operational Check"](#)

\*2 [EM-13, "Checking Drive Belts"](#)

\*3 [HAC-56, "Performance Chart"](#)

## NOISE

< SYMPTOM DIAGNOSIS >

[MANUAL AIR CONDITIONER]

- |    |   |    |   |    |   |
|----|---|----|---|----|---|
| *4 | <a href="#">HA-40. "Removal and Installation for Front Expansion Valve"</a> | *5 | <a href="#">HA-31. "Removal and Installation for Compressor Clutch"</a> | *6 | <a href="#">HA-31. "Removal and Installation for Compressor Clutch"</a> |
| *7 | <a href="#">HA-30. "Removal and Installation for Compressor"</a>            | *8 | <a href="#">HA-20. "Maintenance of Oil Quantity in Compressor"</a>      | *9 | <a href="#">HA-38. "Removal and Installation for Condenser"</a>         |



PRECAUTION

PRECAUTIONS

Precaution for Supplemental Restraint System (SRS) "AIR BAG" and "SEAT BELT PRE-TENSIONER"

INFOID:000000004992406

The Supplemental Restraint System such as "AIR BAG" and "SEAT BELT PRE-TENSIONER", used along with a front seat belt, helps to reduce the risk or severity of injury to the driver and front passenger for certain types of collision. This system includes seat belt switch inputs and dual stage front air bag modules. The SRS system uses the seat belt switches to determine the front air bag deployment, and may only deploy one front air bag, depending on the severity of a collision and whether the front occupants are belted or unbelted. Information necessary to service the system safely is included in the SR and SB section of this Service Manual.

**WARNING:**

- To avoid rendering the SRS inoperative, which could increase the risk of personal injury or death in the event of a collision which would result in air bag inflation, all maintenance must be performed by an authorized NISSAN/INFINITI dealer.
- Improper maintenance, including incorrect removal and installation of the SRS, can lead to personal injury caused by unintentional activation of the system. For removal of Spiral Cable and Air Bag Module, see the SR section.
- Do not use electrical test equipment on any circuit related to the SRS unless instructed to in this Service Manual. SRS wiring harnesses can be identified by yellow and/or orange harnesses or harness connectors.

PRECAUTIONS WHEN USING POWER TOOLS (AIR OR ELECTRIC) AND HAMMERS

**WARNING:**

- When working near the Airbag Diagnosis Sensor Unit or other Airbag System sensors with the Ignition ON or engine running, DO NOT use air or electric power tools or strike near the sensor(s) with a hammer. Heavy vibration could activate the sensor(s) and deploy the air bag(s), possibly causing serious injury.
- When using air or electric power tools or hammers, always switch the Ignition OFF, disconnect the battery, and wait at least 3 minutes before performing any service.

Working with HFC-134a (R-134a)

INFOID:000000003081808

**WARNING:**

- CFC-12 (R-12) refrigerant and HFC-134a (R-134a) refrigerant are not compatible. If the refrigerants are mixed compressor failure is likely to occur. Refer to [HA-4, "Contaminated Refrigerant"](#). To determine the purity of HFC-134a (R-134a) in the vehicle and recovery tank, use Refrigerant Recovery/Recycling Recharging equipment and Refrigerant Identifier.
- Use only specified oil for the HFC-134a (R-134a) A/C system and HFC-134a (R-134a) components. If oil other than that specified is used, compressor failure is likely to occur.
- The specified HFC-134a (R-134a) oil rapidly absorbs moisture from the atmosphere. The following handling precautions must be observed:
  - When removing refrigerant components from a vehicle, immediately cap (seal) the component to minimize the entry of moisture from the atmosphere.
  - When installing refrigerant components to a vehicle, do not remove the caps (unseal) until just before connecting the components. Connect all refrigerant loop components as quickly as possible to minimize the entry of moisture into system.
  - Only use the specified oil from a sealed container. Immediately reseal containers of oil. Without proper sealing, oil will become moisture saturated and should not be used.
  - Avoid breathing A/C refrigerant and oil vapor or mist. Exposure may irritate eyes, nose and throat. Remove HFC-134a (R-134a) from the A/C system using certified service equipment meeting requirements of SAE J2210 [HFC-134a (R-134a) recycling equipment], or J2209 [HFC-134a (R-134a) recycling equipment], If accidental system discharge occurs, ventilate work area before resuming service. Additional health and safety information may be obtained from refrigerant and oil manufacturers.
  - Do not allow A/C oil to come in contact with styrofoam parts. Damage may result.

CONTAMINATED REFRIGERANT

A

B

C

D

E

F

G

H

HAC

J

K

L

M

N

O

P

# PRECAUTIONS

[MANUAL AIR CONDITIONER]

< PRECAUTION >

**If a refrigerant other than pure HFC-134a (R-134a) is identified in a vehicle, your options are:**

- Explain to the customer that environmental regulations prohibit the release of contaminated refrigerant into the atmosphere.
- Explain that recovery of the contaminated refrigerant could damage your service equipment and refrigerant supply.
- Suggest the customer return the vehicle to the location of previous service where the contamination may have occurred.
- If you choose to perform the repair, recover the refrigerant using only **dedicated equipment and containers. Do not recover contaminated refrigerant into your existing service equipment.** If your facility does not have dedicated recovery equipment, you may contact a local refrigerant product retailer for available service. This refrigerant must be disposed of in accordance with all federal and local regulations. In addition, replacement of all refrigerant system components on the vehicle is recommended.
- If the vehicle is within the warranty period, the air conditioner warranty is void. Please contact NISSAN Customer Affairs for further assistance.

## Precaution for Service Equipment

INFOID:000000003081809

### MANIFOLD GAUGE SET

Be certain that the gauge face indicates R-134a or 134a. Make sure the gauge set has 1/2"-16 ACME threaded connections for service hoses. Confirm the set has been used only with refrigerant HFC-134a (R-134a) along with specified oil.

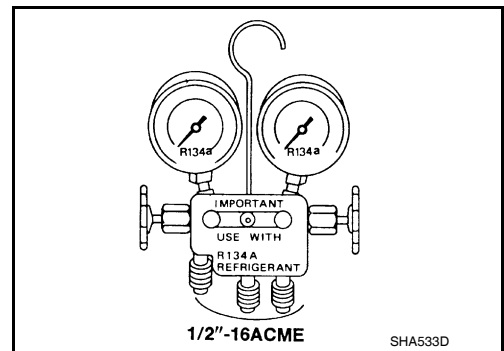

### SERVICE HOSES

Be certain that the service hoses display the markings described (colored hose with black stripe). All hoses must include positive shut-off devices (either manual or automatic) near the end of the hoses opposite the manifold gauge.

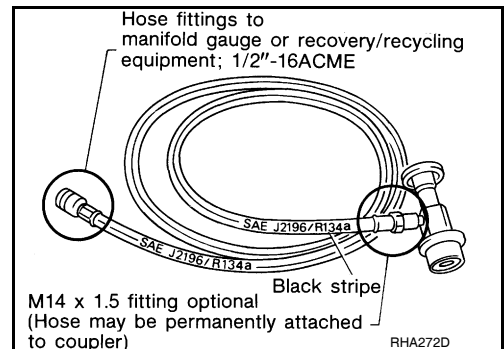

### SERVICE COUPLERS

Never attempt to connect HFC-134a (R-134a) service couplers to a CFC-12 (R-12) A/C system. The HFC-134a (R-134a) couplers will not properly connect to the CFC-12 (R-12) system. However, if an improper connection is attempted, discharging and contamination may occur.

Shut-off valve rotation	A/C service valve
Clockwise	Open
Counterclockwise	Close

