

SECTION VTL
VENTILATION SYSTEM

A
B
C
D
E
F
G
H
VTL
J
K
L
M
N
O
P

CONTENTS

PRECAUTION	2	BLOWER MOTOR	9
PRECAUTIONS	2	Component	9
Precaution for Supplemental Restraint System (SRS) "AIR BAG" and "SEAT BELT PRE-TENSIONER"	2	Removal and Installation	9
Precaution for Working with HFC-134a (R-134a).....	2	FRONT BLOWER MOTOR RESISTOR	10
Precaution for Procedure without Cowl Top Cover.....	3	Removal and Installation	10
PREPARATION	4	HEATER & COOLING UNIT ASSEMBLY	11
PREPARATION	4	Component	11
Special Service Tool	4	Removal and Installation	11
Commercial Service Tool	4	EVAPORATOR	13
FUNCTION DIAGNOSIS	5	Removal and Installation	13
IN-CABIN MICROFILTER	5	HEATER CORE	15
Description	5	Component	15
ON-VEHICLE MAINTENANCE	6	Removal and Installation	15
IN-CABIN MICROFILTER	6	INTAKE DOOR MOTOR	16
Removal and Installation	6	Removal and Installation	16
ON-VEHICLE REPAIR	7	MODE DOOR MOTOR	17
CONTROL UNIT	7	Removal and Installation	17
Removal and Installation	7	AIR MIX DOOR MOTOR	18
INTAKE SENSOR	8	Removal and Installation	18
Removal and Installation	8	DUCTS AND GRILLES	19
		Component	19
		Removal and Installation	20

PRECAUTIONS

< PRECAUTION >

PRECAUTION

PRECAUTIONS

Precaution for Supplemental Restraint System (SRS) "AIR BAG" and "SEAT BELT PRE-TENSIONER"

INFOID:000000004894316

The Supplemental Restraint System such as "AIR BAG" and "SEAT BELT PRE-TENSIONER", used along with a front seat belt, helps to reduce the risk or severity of injury to the driver and front passenger for certain types of collision. This system includes seat belt switch inputs and dual stage front air bag modules. The SRS system uses the seat belt switches to determine the front air bag deployment, and may only deploy one front air bag, depending on the severity of a collision and whether the front occupants are belted or unbelted. Information necessary to service the system safely is included in the SR and SB section of this Service Manual.

WARNING:

- To avoid rendering the SRS inoperative, which could increase the risk of personal injury or death in the event of a collision which would result in air bag inflation, all maintenance must be performed by an authorized NISSAN/INFINITI dealer.
- Improper maintenance, including incorrect removal and installation of the SRS, can lead to personal injury caused by unintentional activation of the system. For removal of Spiral Cable and Air Bag Module, see the SR section.
- Do not use electrical test equipment on any circuit related to the SRS unless instructed to in this Service Manual. SRS wiring harnesses can be identified by yellow and/or orange harnesses or harness connectors.

PRECAUTIONS WHEN USING POWER TOOLS (AIR OR ELECTRIC) AND HAMMERS

WARNING:

- When working near the Airbag Diagnosis Sensor Unit or other Airbag System sensors with the Ignition ON or engine running, DO NOT use air or electric power tools or strike near the sensor(s) with a hammer. Heavy vibration could activate the sensor(s) and deploy the air bag(s), possibly causing serious injury.
- When using air or electric power tools or hammers, always switch the Ignition OFF, disconnect the battery, and wait at least 3 minutes before performing any service.

Precaution for Working with HFC-134a (R-134a)

INFOID:000000003081614

WARNING:

- CFC-12 (R-12) refrigerant and HFC-134a (R-134a) refrigerant are not compatible. If the refrigerants are mixed compressor failure is likely to occur. Refer to [HA-4, "Contaminated Refrigerant"](#). To determine the purity of HFC-134a (R-134a) in the vehicle and recovery tank, use refrigerant recovery/recycling equipment and refrigerant identifier.
- Use only specified oil for the HFC-134a (R-134a) A/C system and HFC-134a (R-134a) components. If oil other than that specified is used, compressor failure is likely to occur.
- The specified HFC-134a (R-134a) oil rapidly absorbs moisture from the atmosphere. The following handling precautions must be observed:
 - When removing refrigerant components from a vehicle, immediately cap (seal) the component to minimize the entry of moisture from the atmosphere.
 - When installing refrigerant components to a vehicle, do not remove the caps (unseal) until just before connecting the components. Connect all refrigerant loop components as quickly as possible to minimize the entry of moisture into system.
 - Only use the specified oil from a sealed container. Immediately reseal containers of oil. Without proper sealing, oil will become moisture saturated and should not be used.
 - Avoid breathing A/C refrigerant and oil vapor or mist. Exposure may irritate eyes, nose and throat. Remove HFC-134a (R-134a) from the A/C system using certified service equipment meeting requirements of SAE J2210 [HFC-134a (R-134a) recycling equipment], or SAE J2209 [HFC-134a (R-134a) recovery equipment]. If accidental system discharge occurs, ventilate work area before resuming service. Additional health and safety information may be obtained from refrigerant and oil manufacturers.
- Do not allow the refrigerant oil to come in contact with styrofoam parts. Damage may result.

PRECAUTIONS

< PRECAUTION >

Precaution for Procedure without Cowl Top Cover

INFOID:000000003081615

When performing the procedure after removing cowl top cover, cover the lower end of windshield with urethane, etc.

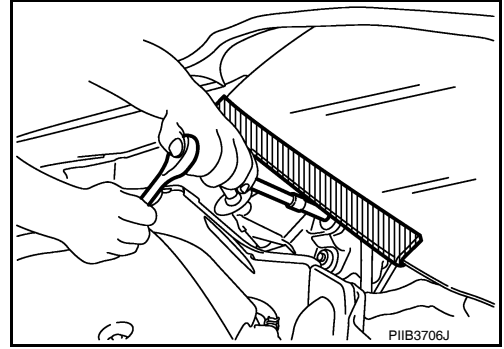

A
B
C
D
E
F
G
H
VTL
J
K
L
M
N
O
P

PREPARATION

< PREPARATION >

PREPARATION

PREPARATION

Special Service Tool

INFOID:000000006071354

The actual shapes of Kent-Moore tools may differ from those of special service tools illustrated here.

Tool number (Kent-Moore No.) Tool name	Description
— (J-46534) Trim Tool Set	Removing trim components

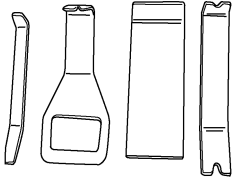

AWJIA0483ZZ

Commercial Service Tool

INFOID:000000003081616

Tool name	Description
Power tool	Loosening bolts and nuts

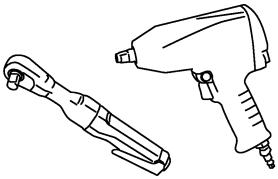

PBIC0190E

IN-CABIN MICROFILTER

< FUNCTION DIAGNOSIS >

FUNCTION DIAGNOSIS

IN-CABIN MICROFILTER

Description

INFOID:000000003081617

FUNCTION

The air inside the passenger compartment is filtered by the in-cabin microfilters when the heater or A/C controls are set on either the recirculation or fresh mode. The two in-cabin microfilters are located in the front heater and cooling unit assembly.

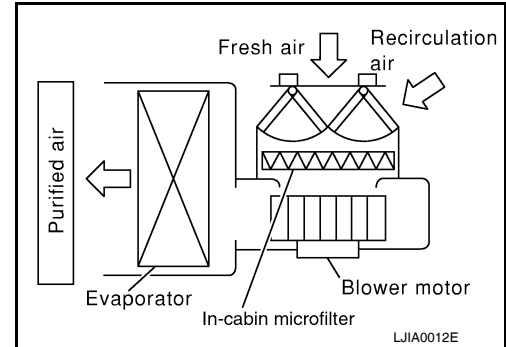

REPLACEMENT TIMING

Replacement of the two in-cabin microfilters is recommended on a regular interval depending on the driving conditions. Refer to [MA-8. "Introduction of Periodic Maintenance"](#). It may also be necessary to replace the two in-cabin microfilters as part of a component replacement if the in-cabin microfilters are damaged.

A
B
C
D
E
F
G
H
J
K
L
M
N
O
P

VTL

IN-CABIN MICROFILTER

< ON-VEHICLE MAINTENANCE >

ON-VEHICLE MAINTENANCE

IN-CABIN MICROFILTER

Removal and Installation

INFOID:000000004894317

REPLACEMENT PROCEDURE

1. Open the lower glove box and press in on the sides as shown so that it will open completely, allowing it to hang by the cord.

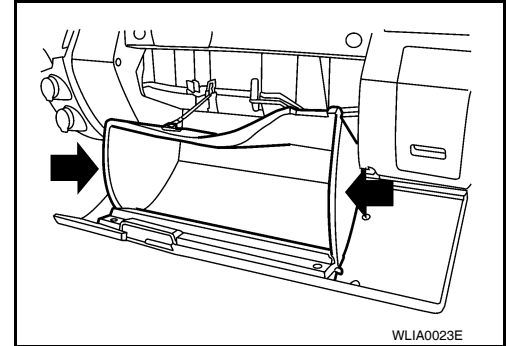

2. Push down on the lock tab and remove the in-cabin microfilter cover as shown.

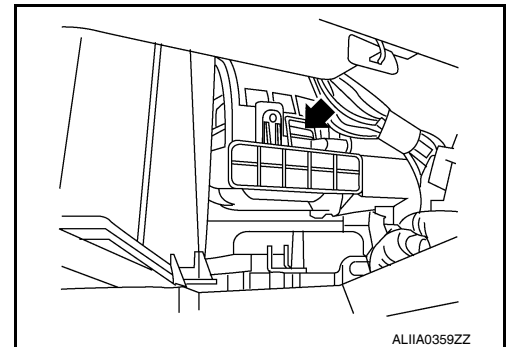

3. Remove the in-cabin microfilters from the front heater and cooling unit housing.
4. Insert the first new in-cabin microfilter into the front heater and cooling unit housing and slide it over to the right. Insert the second new in-cabin microfilter into the front heater and cooling unit housing as shown.

NOTE:

The in-cabin microfilters are marked with air flow arrows. The end of the microfilter with the arrow should face the rear of the vehicle. The arrows should point downward.

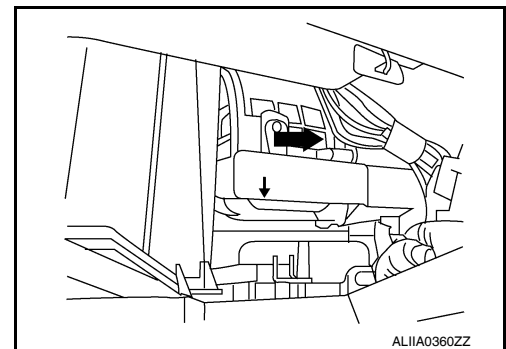

5. Install the in-cabin microfilter cover making sure the lock tab is securely locked in place as shown.

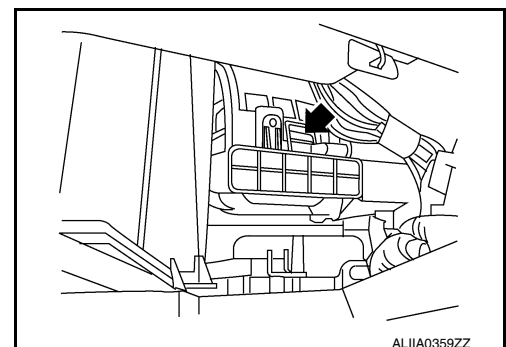

6. Close the lower glove box completely.

CONTROL UNIT

< ON-VEHICLE REPAIR >

ON-VEHICLE REPAIR

CONTROL UNIT

Removal and Installation

INFOID:000000003248913

FRONT AIR CONTROL

Removal

1. Remove cluster lid C. Refer to [IP-11. "Exploded View"](#)
2. Remove the four screws securing the front air control to cluster lid C.
3. Remove the front air control.

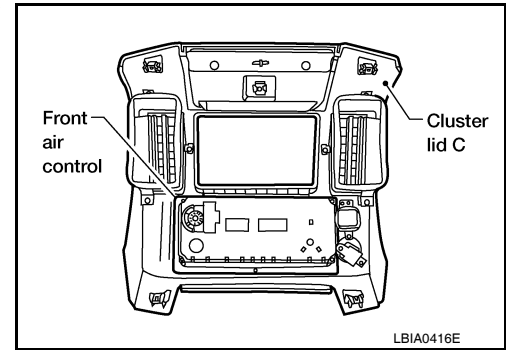

Installation

Installation is in the reverse order of removal.

A

B

C

D

E

F

G

H

VTL

J

K

L

M

N

O

P

INTAKE SENSOR

< ON-VEHICLE REPAIR >

INTAKE SENSOR

Removal and Installation

INFOID:000000003081622

REMOVAL

1. Remove the front kick plate. Refer to [INT-17, "Removal and Installation"](#).
2. Remove the lower dash side finisher. Refer to [IP-11, "Exploded View"](#).
3. Remove the front pillar lower finisher. Refer to [INT-17, "Removal and Installation"](#).
4. Remove the assist grip handle.
5. Remove the front pillar upper finisher. Refer to [INT-17, "Removal and Installation"](#).
6. Remove the lower glove box. Refer to [IP-11, "Exploded View"](#).
7. Remove the upper glove box (cluster lid E). Refer to [IP-11, "Exploded View"](#).
8. Disconnect the intake sensor electrical connector.

NOTE:

The intake sensor is located on the top of the front heater and cooling unit assembly next to the A/C evaporator cover.

9. Twist the intake sensor to remove the intake sensor from the front heater and cooling unit assembly.

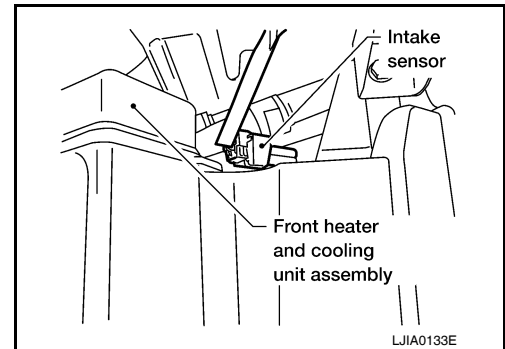

INSTALLATION

Installation is in the reverse order of removal.

BLOWER MOTOR

< ON-VEHICLE REPAIR >

BLOWER MOTOR

Component

INFOID:000000003081623

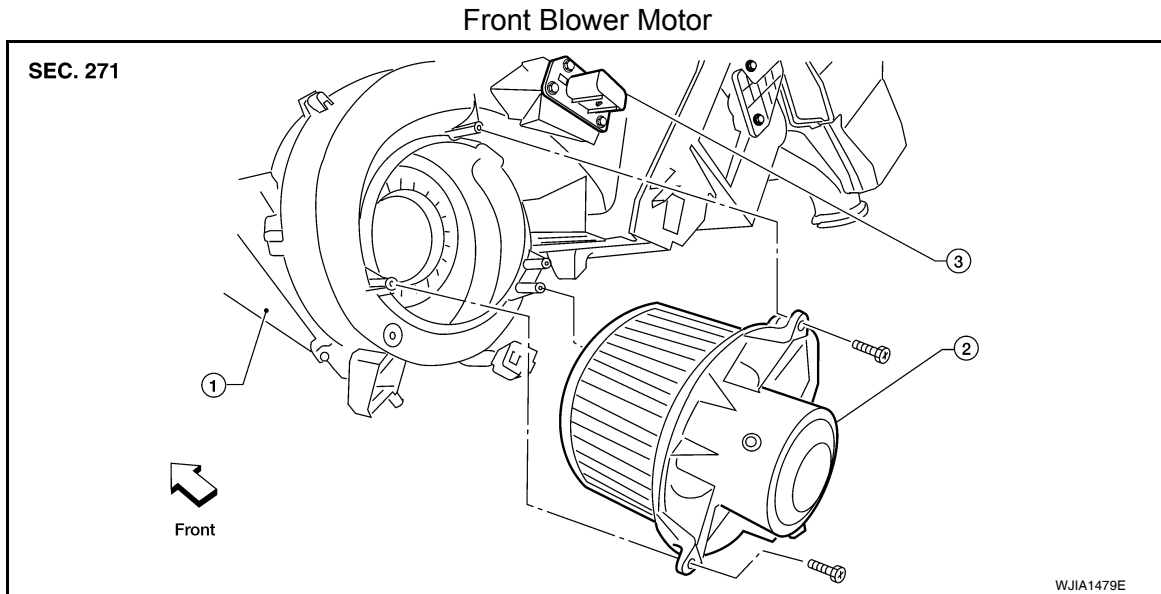

1. Front heater and cooling unit assembly
2. Front blower motor
3. Blower motor resistor

Removal and Installation

INFOID:000000003081624

FRONT BLOWER MOTOR

Removal

1. Remove the lower glove box assembly. Refer to [JP-11, "Exploded View"](#).
2. Disconnect the front blower motor electrical connector.
3. Remove the three screws and remove the front blower motor.

Installation

Installation is in the reverse order of removal.

A
B
C
D
E
F
G
H
VTL
J
K
L
M
N
O
P

FRONT BLOWER MOTOR RESISTOR

< ON-VEHICLE REPAIR >

FRONT BLOWER MOTOR RESISTOR

Removal and Installation

INFOID:000000003081627

Blower Motor Resistor - Front Heater and Cooling Unit Assembly

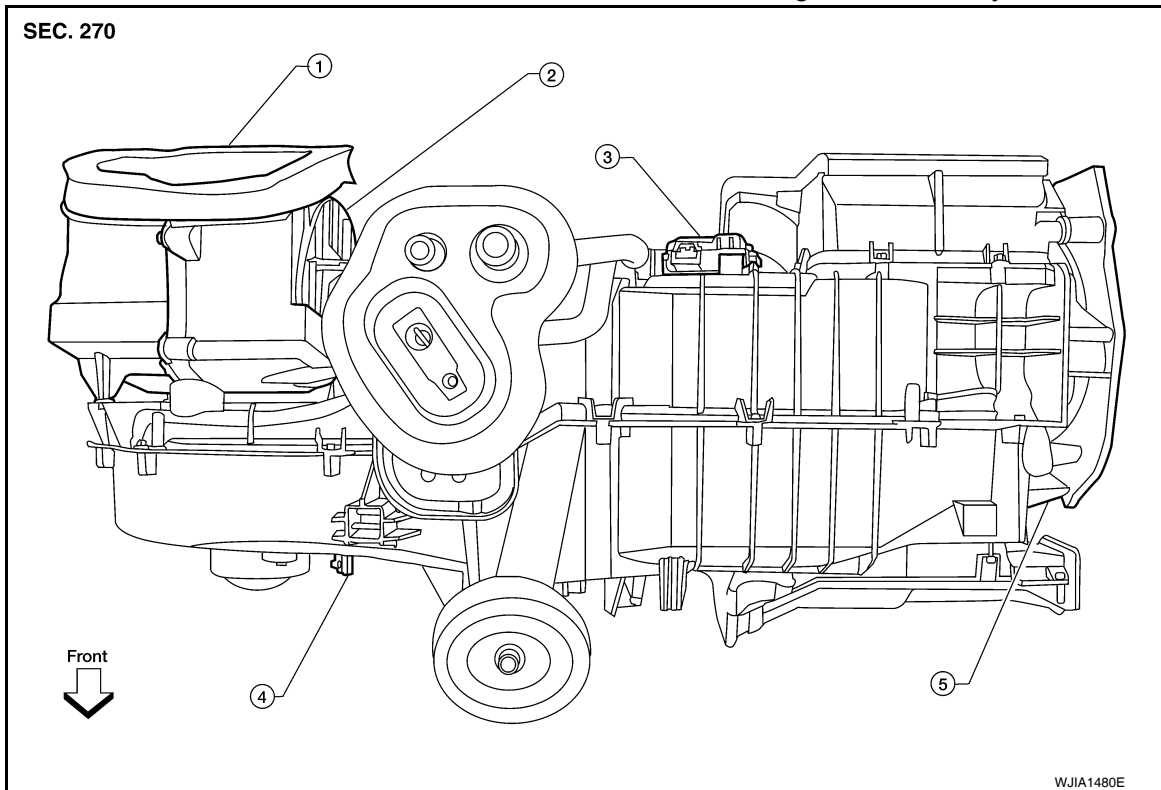

- | | | |
|---|----------------------|-----------------------|
| 1. Front heater and cooling unit assembly | 2. Intake door motor | 3. Air mix door motor |
| 4. Blower motor resistor | 5. Mode door motor | |

REMOVAL

1. Disconnect the blower motor resistor electrical connector.
2. Remove the two screws and remove the blower motor resistor.

INSTALLATION

Installation is in the reverse order of removal.

HEATER & COOLING UNIT ASSEMBLY

< ON-VEHICLE REPAIR >

HEATER & COOLING UNIT ASSEMBLY

Component

INFOID:000000003081628

Front Heater and Cooling Unit Assembly

SEC. 271 • 276 • 278

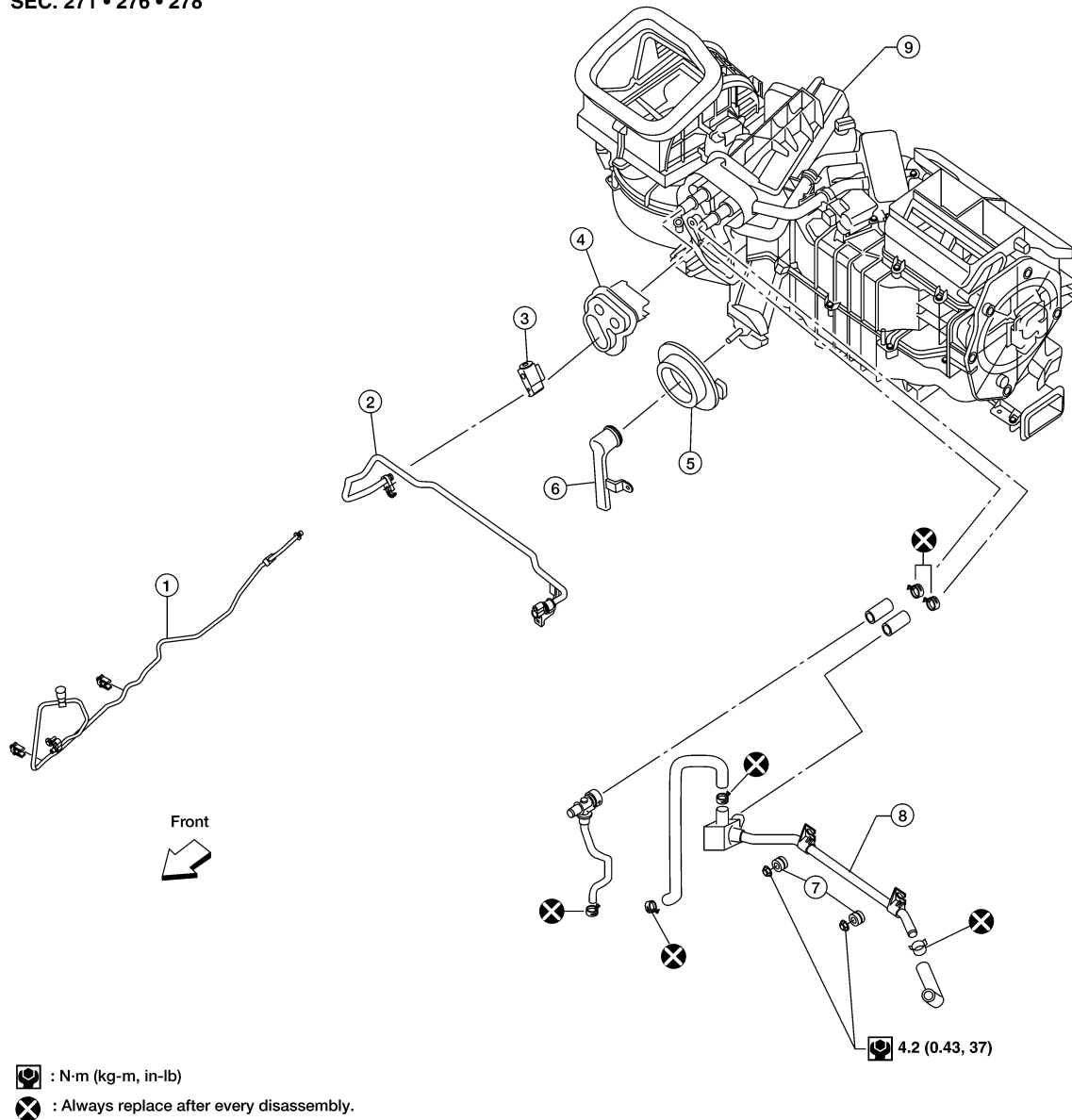

 : N·m (kg·m, in·lb)

 : Always replace after every disassembly.

WJIA1621E

- | | | |
|---|---------------------------------|---|
| 1. Front high-pressure A/C pipe | 2. Front low-pressure A/C pipe | 3. Front expansion valve |
| 4. Front heater core and evaporator pipes grommet | 5. Front A/C drain hose grommet | 6. Front A/C drain hose |
| 7. Front heater core pipe mounts | 8. Front heater core pipes | 9. Front heater and cooling unit assembly |

Removal and Installation

INFOID:000000003081629

FRONT HEATER AND COOLING UNIT ASSEMBLY

Removal

1. Discharge the refrigerant from the A/C system. Refer to [HA-29. "HFC-134a \(R-134a\) Service Procedure"](#).
2. Drain the coolant from the engine cooling system. Refer to [CO-11. "Changing Engine Coolant"](#).
3. Disconnect the battery negative and positive terminals.

HEATER & COOLING UNIT ASSEMBLY

< ON-VEHICLE REPAIR >

4. Remove the front heater core pipes RH nut.
5. Disconnect the front heater core hoses from the front heater core.
6. Disconnect the high- and low-pressure A/C pipes from the front expansion valve.
7. Move the two front seats to the rearmost position on the seat track.
8. Remove the instrument panel and console panel. Refer to [IP-11, "Removal and Installation"](#).
9. Remove the two front floor ducts.
10. Remove the steering column. Refer to [ST-14, "Removal and Installation"](#).
11. Disconnect the instrument panel wire harness at the RH and LH in-line connector brackets, and the fuse block (SMJ) electrical connectors. Refer to [PCS-8, "Component Parts Location"](#).
12. Remove the covers then remove the three steering member bolts from each side to disconnect the steering member from the vehicle body.
13. Remove the front heater and cooling unit assembly with it attached to the steering member, from the vehicle.
CAUTION:
 - Use care not to damage the seats and interior trim panels when removing the front heater and cooling unit assembly with it attached to the steering member.
 - Use suitable plugs on the heater core pipes to prevent coolant leakage.
14. Remove the front heater and cooling unit assembly from the steering member.

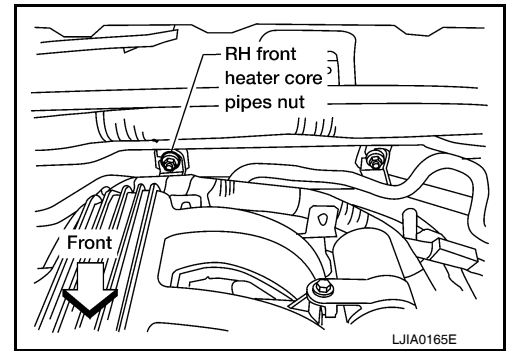

Installation

Installation is in the reverse order of removal.

CAUTION:

- Replace the O-ring of the low-pressure A/C pipe and high-pressure A/C pipe with a new one, and apply compressor oil to the O-ring for installation. Refer to [HA-27, "Component"](#).
- After charging the refrigerant, check for leaks. Refer to [HA-22, "Checking of Refrigerant Leaks"](#).

NOTE:

- Fill the engine cooling system with the specified coolant mixture. Refer to [CO-11, "Changing Engine Coolant"](#).
- Recharge the A/C system. Refer to [HA-29, "HFC-134a \(R-134a\) Service Procedure"](#).

EVAPORATOR

< ON-VEHICLE REPAIR >

EVAPORATOR

Removal and Installation

INFOID:000000003081630

Front Heater and Cooling Unit Assembly

SEC. 270 • 271 • 272

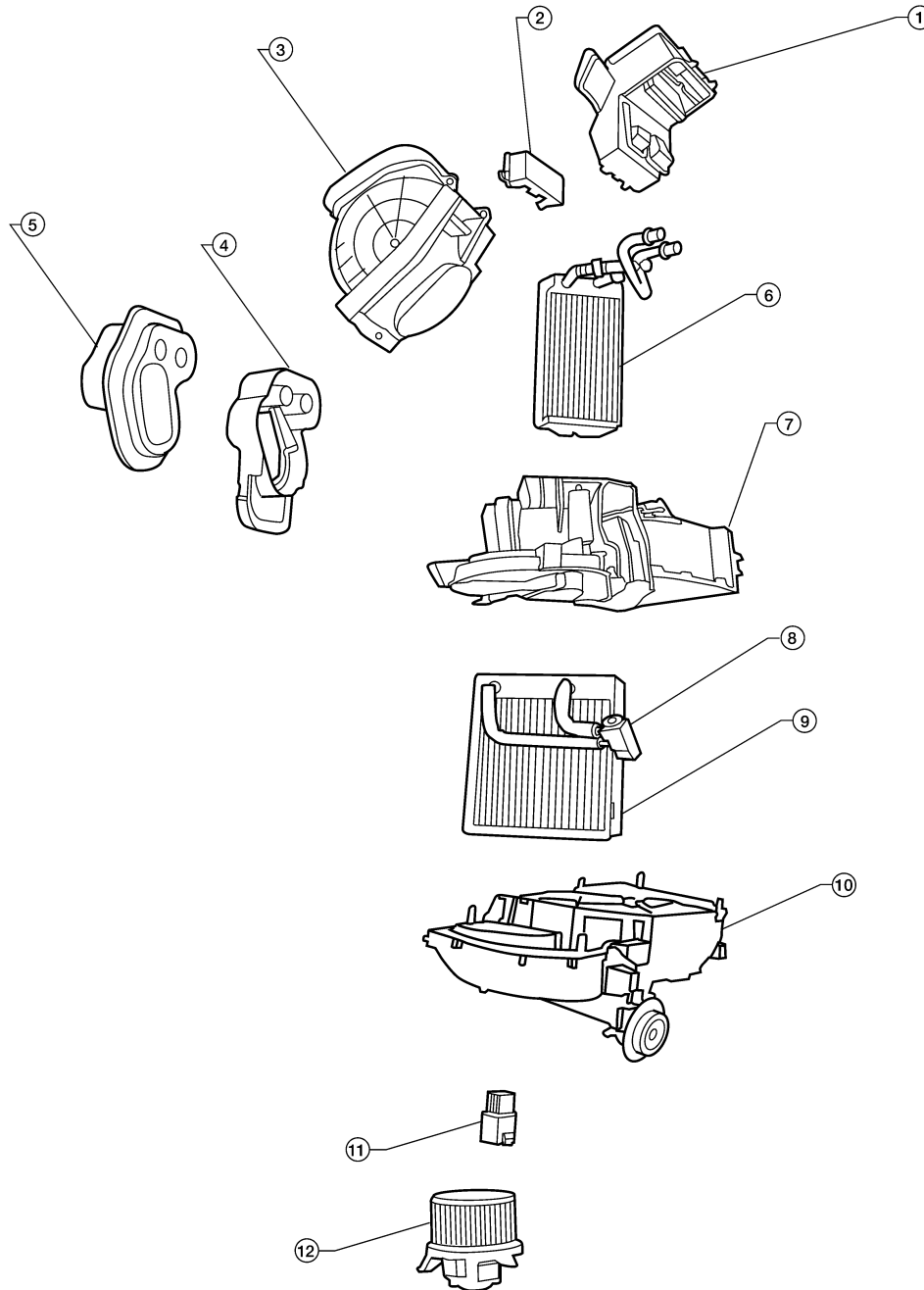

A
B
C
D
E
F
G
H
VTL
J
K
L
M
N
O
P

- | | | |
|---|---|----------------------|
| 1. Center ventilator connector duct | 2. Front heater core cover | 3. Intake air case |
| 4. Front heater core and evaporator pipes bracket | 5. Front heater core and evaporator pipes grommet | 6. Front heater core |
| 7. Upper heater and cooling unit case | 8. Front expansion valve | 9. Front evaporator |
| 10. Lower heater and cooling unit case | 11. Blower motor resistor | 12. Blower motor |

LJIA0178E

REMOVAL

EVAPORATOR

< ON-VEHICLE REPAIR >

1. Remove the front heater core. Refer to [VTL-15. "Removal and Installation"](#).
2. Separate the heater and cooling unit case.
3. Remove the front evaporator.

INSTALLATION

Installation is in the reverse order of removal.

CAUTION:

Replace the O-rings on the front A/C low-pressure flexible A/C hose and the front high-pressure A/C pipe with new ones. Apply compressor oil to the O-rings for installation.

HEATER CORE

< ON-VEHICLE REPAIR >

HEATER CORE

Component

INFOID:000000003081633

Front Heater and Cooling Unit Assembly

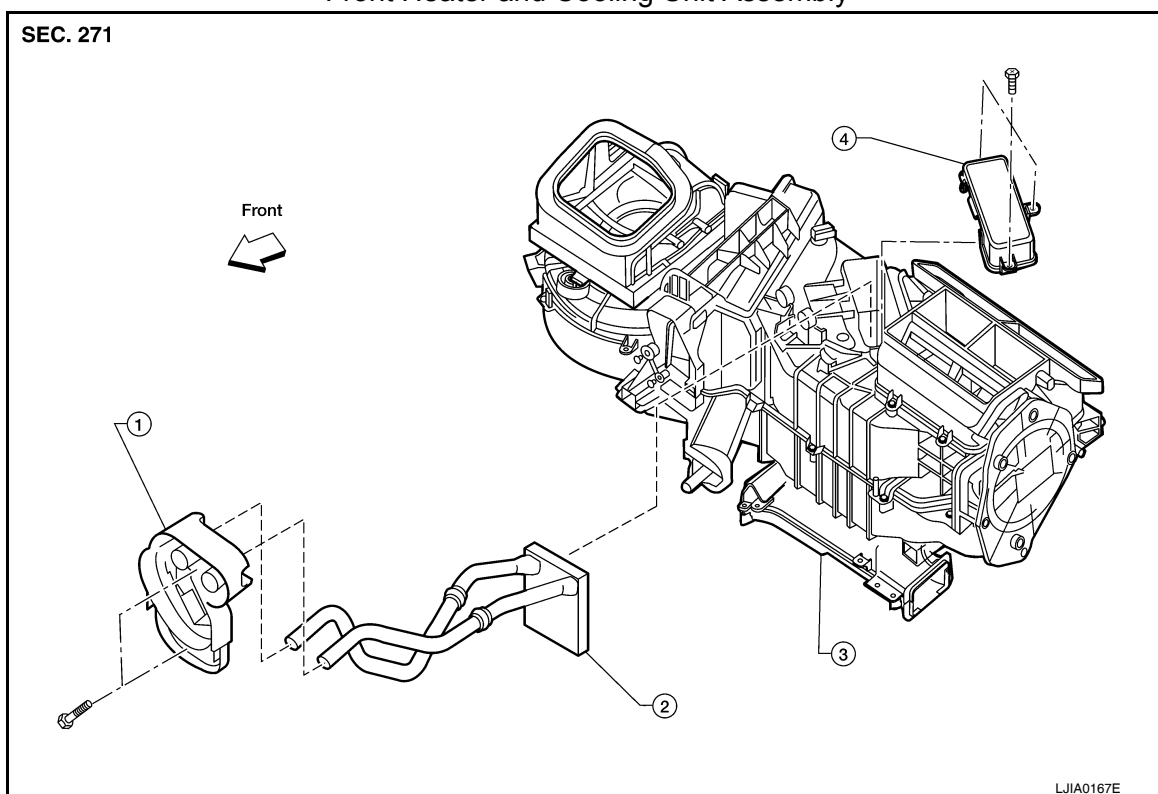

1. Front heater core and evaporator pipe
2. Front heater core bracket
3. Front heater and cooling unit assembly
4. Front heater core cover

Removal and Installation

INFOID:000000003081634

FRONT HEATER CORE

Removal

1. Remove the front heater and cooling unit assembly. Refer to [VTL-11, "Removal and Installation"](#).
2. Remove the three screws and remove the front heater core cover.
3. Remove the front heater core and evaporator pipe bracket.
4. Remove the front heater core.

NOTE:

If the in-cabin microfilters are contaminated from coolant leaking from the front heater core, replace the in-cabin microfilters with new ones before installing the new front heater core.

Installation

Installation is in the reverse order of removal.

INTAKE DOOR MOTOR

< ON-VEHICLE REPAIR >

INTAKE DOOR MOTOR

Removal and Installation

INFOID:000000003081635

Intake Door Motor - Front Heater and Cooling Unit Assembly

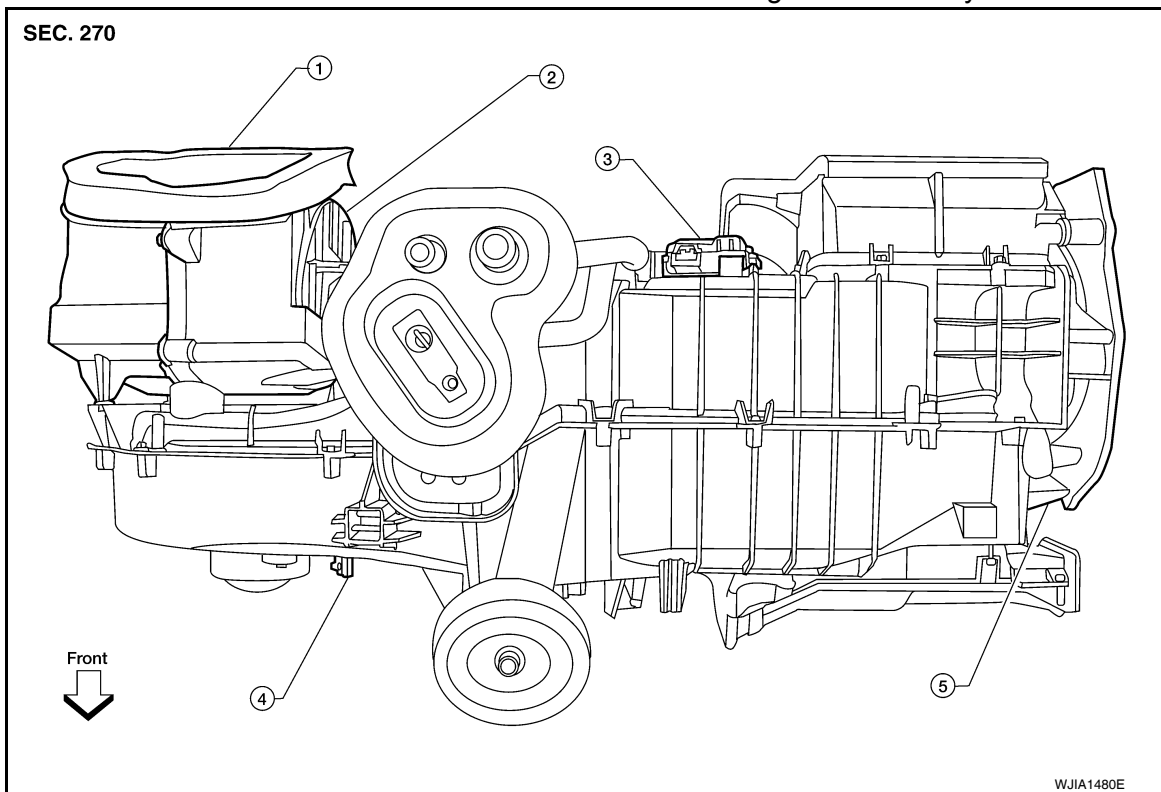

- | | | |
|---|----------------------|-----------------------|
| 1. Front heater and cooling unit assembly | 2. Intake door motor | 3. Air mix door motor |
| 4. Blower motor resistor | 5. Mode door motor | |

REMOVAL

1. Remove the front heater and cooling unit assembly. Refer to [VTL-11, "Removal and Installation"](#).
2. Disconnect the intake door motor electrical connector.
3. Remove the three screws and remove the intake door motor.

INSTALLATION

Installation is in the reverse order of removal.

MODE DOOR MOTOR

< ON-VEHICLE REPAIR >

MODE DOOR MOTOR

Removal and Installation

INFOID:000000003081636

Mode Door Motor - Front Heater and Cooling Unit Assembly

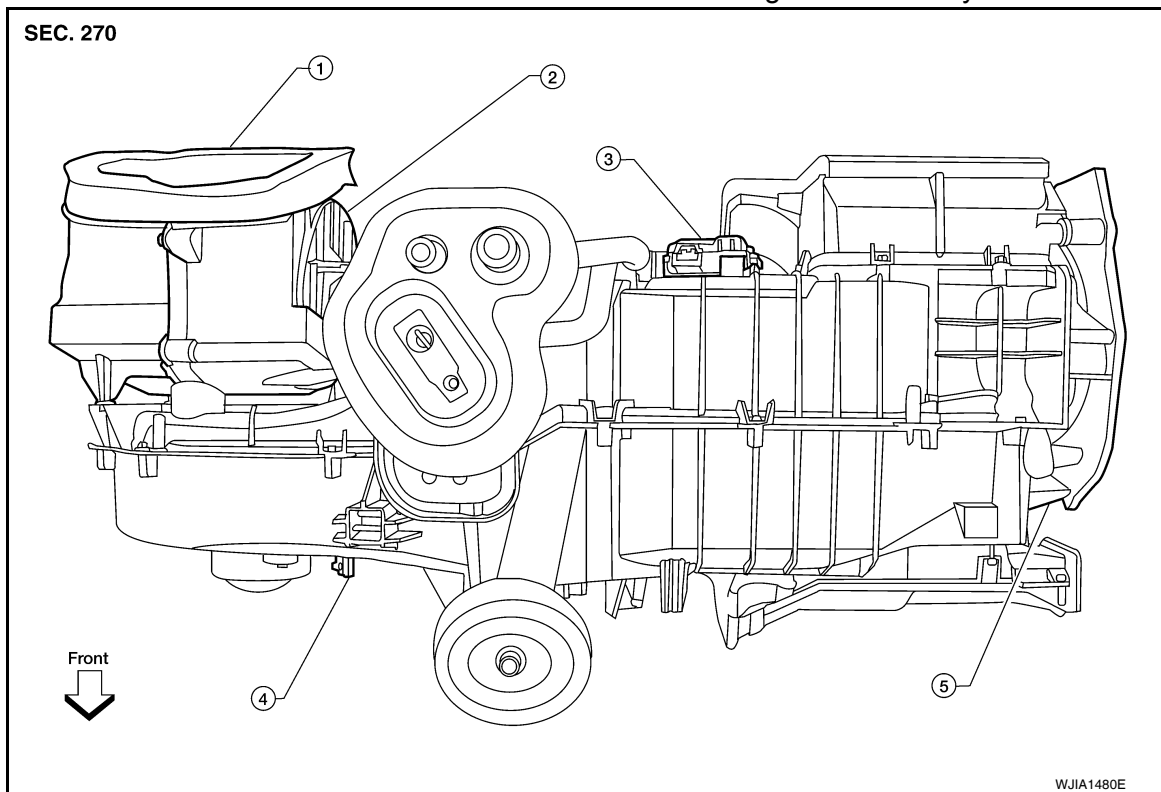

1. Front heater and cooling unit assembly
2. Intake door motor
3. Air mix door motor
4. Blower motor resistor
5. Mode door motor

REMOVAL

1. Remove the instrument panel side finisher. Refer to [IP-11, "Exploded View"](#).
2. Remove the lower instrument cover. Refer to [IP-11, "Exploded View"](#).
3. Disconnect the mode door motor electrical connector.
4. Remove the three screws and remove the mode door motor.

INSTALLATION

Installation is in the reverse order of removal.

A
B
C
D
E
F
G
H
VTL
J
K
L
M
N
O
P

AIR MIX DOOR MOTOR

< ON-VEHICLE REPAIR >

AIR MIX DOOR MOTOR

Removal and Installation

INFOID:000000003081638

Air Mix Door Motor - Front Heater and Cooling Unit Assembly

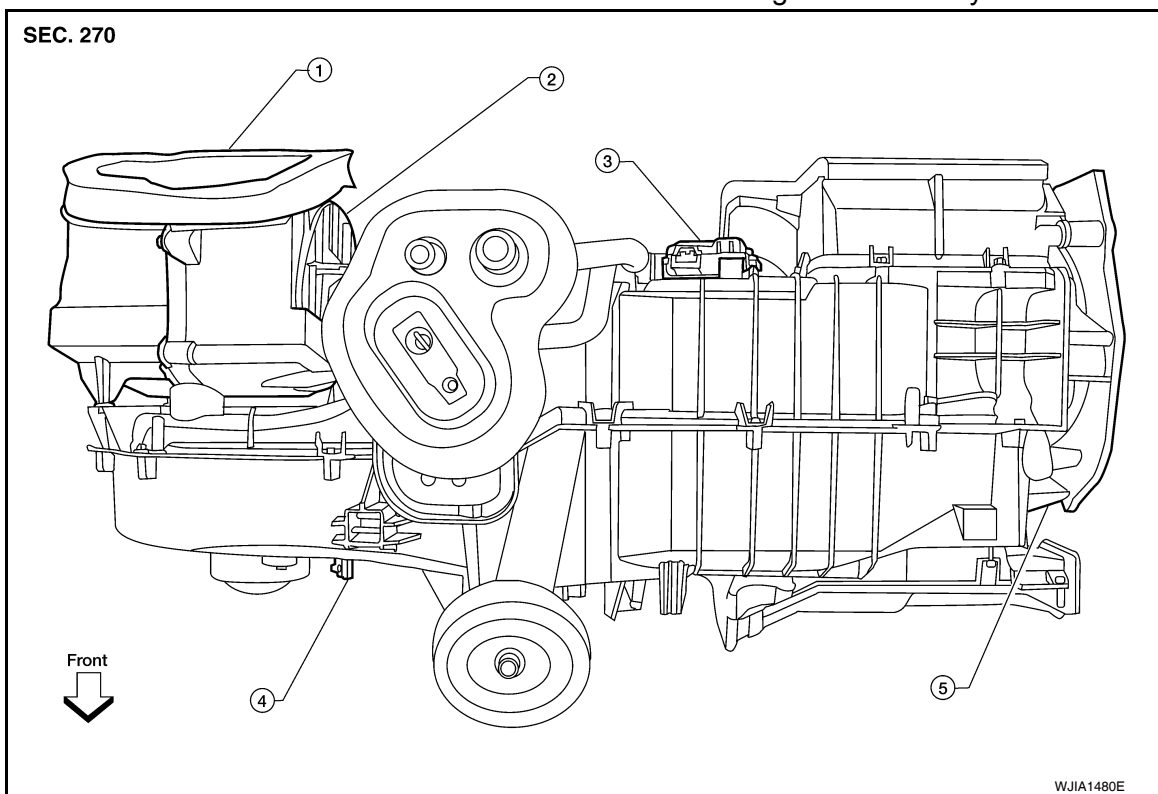

- | | | |
|---|----------------------|-----------------------|
| 1. Front heater and cooling unit assembly | 2. Intake door motor | 3. Air mix door motor |
| 4. Blower motor resistor | 5. Mode door motor | |

REMOVAL

1. Remove the front heater and cooling unit assembly. Refer to [VTL-11, "Removal and Installation"](#).
2. Disconnect the air mix door motor electrical connector.
3. Remove the three screws and remove the air mix door motor.

INSTALLATION

Installation is in the reverse order of removal.

DUCTS AND GRILLES

< ON-VEHICLE REPAIR >

DUCTS AND GRILLES

Component

INFOID:000000003081639

SEC. 270 • 271

Ducts

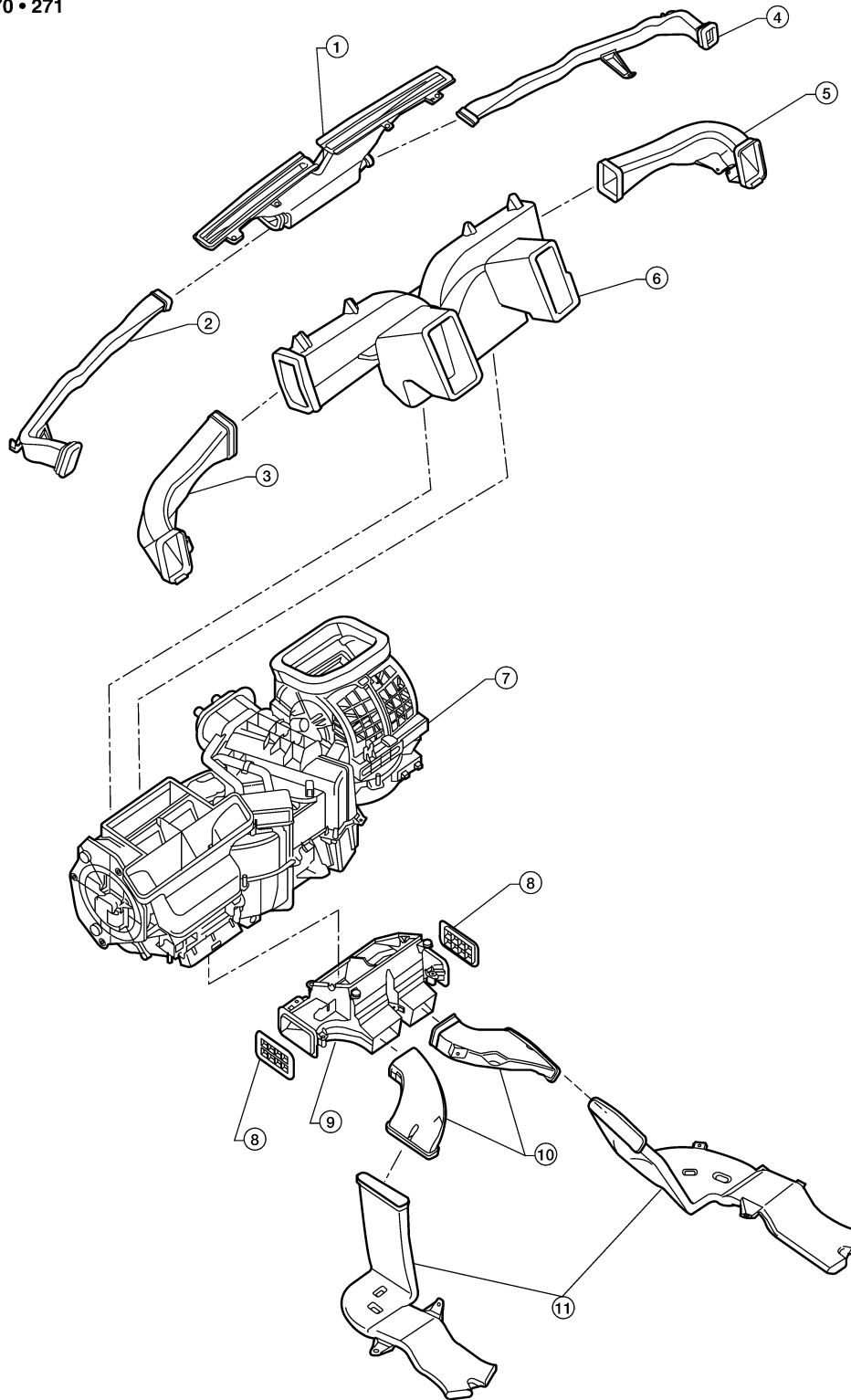

- 1. Defroster nozzle
- 4. RH side demister duct

- 2. LH side demister duct
- 5. RH ventilator duct

- 3. LH ventilator duct
- 6. Center ventilator duct

WJIA1260E

DUCTS AND GRILLES

< ON-VEHICLE REPAIR >

- 7. Front heater and cooling unit assembly
- 8. Floor connector duct grilles
- 9. Floor connector duct
- 10. Front floor ducts
- 11. Rear floor ducts

Grilles

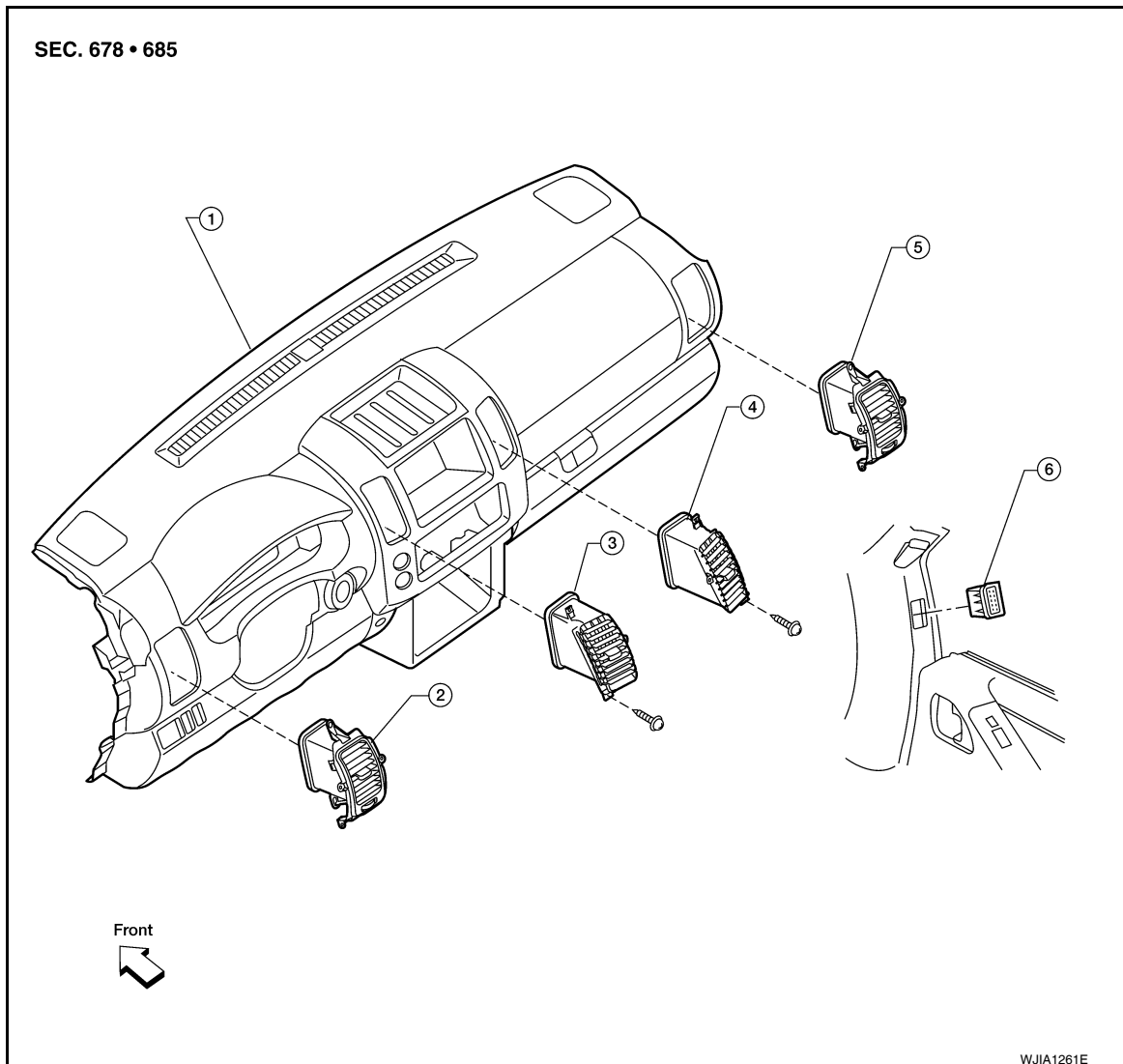

- 1. Instrument panel and pad assembly
- 2. LH side ventilator grille
- 3. LH ventilator grille
- 4. RH ventilator grille
- 5. RH side ventilator grille
- 6. RH side demister grille

Removal and Installation

INFOID:000000003081640

DEFROSTER NOZZLE

Removal

1. Remove the front heater and cooling unit assembly. Refer to [VTL-11. "Removal and Installation"](#).
2. Remove the defroster nozzle.

Installation

Installation is in the reverse order of removal.

RH AND LH SIDE DEMISTER DUCT

Removal

1. Remove the front heater and cooling unit assembly. Refer to [VTL-11. "Removal and Installation"](#).
2. Remove the RH or LH side demister duct.

Installation

DUCTS AND GRILLES

< ON-VEHICLE REPAIR >

Installation is in the reverse order of removal.

RH AND LH VENTILATOR DUCT

Removal

1. Remove the front heater and cooling unit assembly. Refer to [VTL-11, "Removal and Installation"](#).
2. Remove the RH or LH ventilator duct.

Installation

Installation is in the reverse order of removal.

CENTER VENTILATOR DUCT

Removal

1. Remove the front heater and cooling unit assembly. Refer to [VTL-11, "Removal and Installation"](#).
2. Remove the defroster nozzle.
3. Remove the RH and LH ventilator ducts.
4. Remove the RH and LH side demister ducts.
5. Remove the center ventilator duct.

Installation

Installation is in the reverse order of removal.

FLOOR CONNECTOR DUCT

Removal

1. Remove the front heater and cooling unit assembly. Refer to [VTL-11, "Removal and Installation"](#).
2. Remove the floor connector duct.

Installation

Installation is in the reverse order of removal.

FRONT AND REAR FLOOR DUCTS

Removal

1. Remove the floor carpet. Refer to [INT-18, "Removal and Installation"](#).
2. Remove the clips and remove the front and rear floor ducts.

Installation

Installation is in the reverse order of removal.

GRILLES

Removal

1. Remove the necessary interior trim panel(s) to access the grille. Refer to [IP-11, "Exploded View"](#).
2. Remove the grille from the interior trim panel.

Installation

Installation is in the reverse order of removal.

A

B

C

D

E

F

G

H

VTL

J

K

L

M

N

O

P