

SECTION **FL**
FUEL SYSTEM

A
FL
C
D
E
F
G
H
I
J
K
L
M
N
O
P

CONTENTS

PRECAUTION	2	FUEL TANK	6
PRECAUTIONS	2	Removal and Installation	6
Precaution for Supplemental Restraint System (SRS) "AIR BAG" and "SEAT BELT PRE-TEN- SIONER"	2	FUEL LEVEL SENSOR UNIT, FUEL FILTER AND FUEL PUMP ASSEMBLY	11
General Precaution	2	Removal and Installation	11
PREPARATION	4	DISASSEMBLY AND ASSEMBLY	16
PREPARATION	4	FUEL LEVEL SENSOR UNIT, FUEL FILTER AND FUEL PUMP ASSEMBLY	16
Special Service Tool	4	Disassembly and Assembly	16
Commercial Service Tool	4	SERVICE DATA AND SPECIFICATIONS (SDS)	17
ON-VEHICLE MAINTENANCE	5	SERVICE DATA AND SPECIFICATIONS (SDS)	17
FUEL SYSTEM	5	Standard and Limit	17
Checking Fuel Line	5		
ON-VEHICLE REPAIR	6		

PRECAUTIONS

< PRECAUTION >

PRECAUTION

PRECAUTIONS

Precaution for Supplemental Restraint System (SRS) "AIR BAG" and "SEAT BELT PRE-TENSIONER"

INFOID:000000005530134

The Supplemental Restraint System such as "AIR BAG" and "SEAT BELT PRE-TENSIONER", used along with a front seat belt, helps to reduce the risk or severity of injury to the driver and front passenger for certain types of collision. This system includes seat belt switch inputs and dual stage front air bag modules. The SRS system uses the seat belt switches to determine the front air bag deployment, and may only deploy one front air bag, depending on the severity of a collision and whether the front occupants are belted or unbelted. Information necessary to service the system safely is included in the SR and SB section of this Service Manual.

WARNING:

- To avoid rendering the SRS inoperative, which could increase the risk of personal injury or death in the event of a collision which would result in air bag inflation, all maintenance must be performed by an authorized NISSAN/INFINITI dealer.
- Improper maintenance, including incorrect removal and installation of the SRS, can lead to personal injury caused by unintentional activation of the system. For removal of Spiral Cable and Air Bag Module, see the SR section.
- Do not use electrical test equipment on any circuit related to the SRS unless instructed to in this Service Manual. SRS wiring harnesses can be identified by yellow and/or orange harnesses or harness connectors.

PRECAUTIONS WHEN USING POWER TOOLS (AIR OR ELECTRIC) AND HAMMERS

WARNING:

- When working near the Airbag Diagnosis Sensor Unit or other Airbag System sensors with the Ignition ON or engine running, DO NOT use air or electric power tools or strike near the sensor(s) with a hammer. Heavy vibration could activate the sensor(s) and deploy the air bag(s), possibly causing serious injury.
- When using air or electric power tools or hammers, always switch the Ignition OFF, disconnect the battery, and wait at least 3 minutes before performing any service.

General Precaution

INFOID:000000005269038

WARNING:

When replacing fuel line parts, be sure to observe the following.

- Put a "CAUTION: FLAMMABLE" sign in the workshop.
- Be sure to work in a well ventilated area and furnish the workshop with a CO₂ fire extinguisher.
- Do not smoke while servicing the fuel system. Keep open flames and sparks away from the work area.

CAUTION:

- Use gasoline required by the regulations for the octane rating number. Refer to [GI-26, "Precaution for Fuel"](#).
- Before removing fuel line parts, carry out the following procedures:
 - Put drained fuel in an explosion-proof container and put the lid on securely. Keep the container in safe area.
 - Release fuel pressure from the fuel lines. Refer to [EC-500, "Fuel Pressure Check"](#).
 - Disconnect the battery negative terminal.
- Always replace O-rings and clamps with new ones.
- Do not kink or twist hoses when they are being installed.
- Do not tighten hose clamps excessively to avoid damaging hoses.
- Tighten high-pressure rubber hose clamp so that clamp end is 3 mm (0.12 in) from hose end.
- Ensure that clamp screw does not contact adjacent parts.

PRECAUTIONS

< PRECAUTION >

- After connecting the fuel tube quick connectors, make sure the quick connectors are secure. Ensure that the connector and resin tube do not contact any adjacent parts.
- After installing tubes, make sure there is no fuel leakage at connections in the following steps.
- Apply fuel pressure to fuel lines with turning ignition switch ON (with engine stopped). Then check for fuel leaks at connections.
- Start the engine and rev it up and check for fuel leaks at connections.
- Use only a Genuine NISSAN fuel filler cap as a replacement. If an incorrect fuel filler cap is used, the MIL may come on.
- For servicing "Evaporative Emission System" parts, refer to [EC-503, "Removal and Installation"](#).
- For servicing "On Board Refueling Vapor Recovery (ORVR)" parts, refer to [EC-502, "How to Detect Fuel Vapor Leakage"](#).

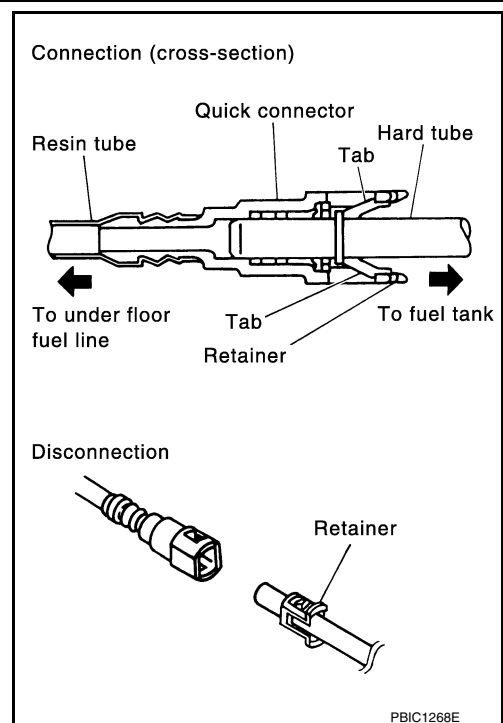

A

FL

C

D

E

F

G

H

I

J

K

L

M

N

O

P

PREPARATION

< PREPARATION >

PREPARATION

PREPARATION

Special Service Tool

INFOID:000000005269039

The actual shapes of the Kent-Moore tools may differ from those of the special tools illustrated here.

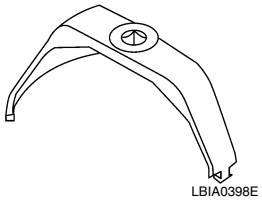
Tool number (Kent-Moore No.) Tool name	Description
— (J-45722) 130 mm lock ring tool 	Removing and installing fuel tank lock ring

Commercial Service Tool

INFOID:000000005269040

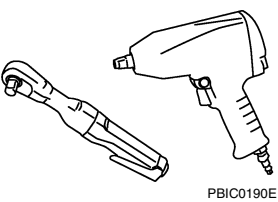
Tool name	Description
Power tool 	Loosening bolts and nuts

FUEL SYSTEM

< ON-VEHICLE MAINTENANCE >

ON-VEHICLE MAINTENANCE

FUEL SYSTEM

Checking Fuel Line

INFOID:000000005269041

Inspect fuel lines, fuel filler cap and fuel tank for improper attachment, leaks, cracks, damage, loose connections, chafing or deterioration.

If necessary, repair or replace damaged parts.

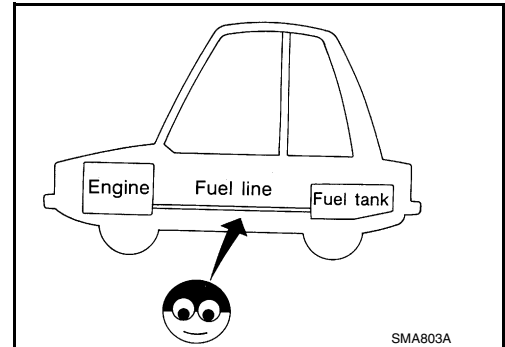

A

FL

C

D

E

F

G

H

I

J

K

L

M

N

O

P

FUEL TANK

< ON-VEHICLE REPAIR >

ON-VEHICLE REPAIR

FUEL TANK

Removal and Installation

INFOID:000000005269042

SEC. 172

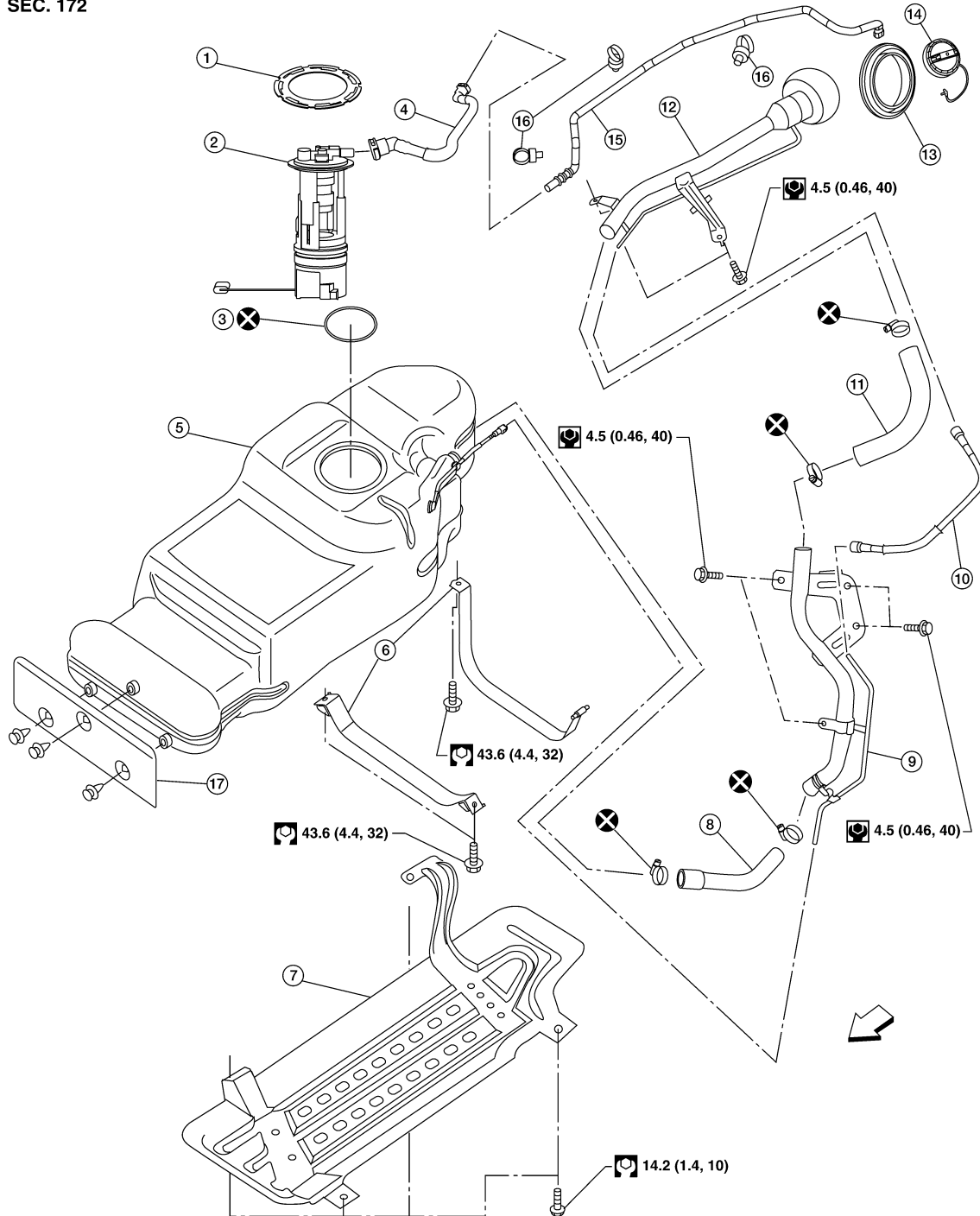

AWBIA0874GB

- | | | |
|---------------------|---|--|
| 1. Lock ring | 2. Fuel level sensor, fuel filter, and fuel pump assembly | 3. Fuel level sensor, fuel filter, and fuel pump assembly O-ring |
| 4. EVAP hose | 5. Fuel tank | 6. Fuel tank straps |
| 7. Fuel tank shield | 8. Lower fuel filler hose | 9. Fuel filler pipe and vent pipe |
| 10. Vent hose | 11. Upper fuel filler hose | 12. Fuel filler pipe and cup |

FUEL TANK

< ON-VEHICLE REPAIR >

- 13. Fuel filler pipe cup grommet
- 16. Clip

- 14. Fuel filler cap
- 17. Fuel tank protector

- 15. EVAP Canister hose
- ⇐ Front

REMOVAL

WARNING:

Follow the “General Precautions” before working on the fuel system. Refer to [FL-2. "General Precaution"](#).

1. Remove the fuel filler cap to release the pressure from inside the fuel tank.
2. Check the fuel level on level gauge. If the fuel gauge indicates more than the level as shown (full or almost full), drain the fuel from the fuel tank until the fuel gauge indicates the level as shown, or less.

NOTE:

Fuel will be spilled when removing the fuel level sensor, fuel filter, and fuel pump assembly for the fuel level is above the fuel level sensor, fuel filter, and fuel pump assembly fuel tank opening.

- As a guide, the fuel level reaches the fuel gauge position as shown, or less, when approximately 15 ℓ (4 US gal, 3 1/4 Imp gal) of fuel are drained from the fuel tank.
 - If the fuel pump does not operate, use the following procedure to drain the fuel to the specified level.
- a. Insert a suitable hose of less than 15 mm (0.59 in) diameter into the fuel filler pipe through the fuel filler opening to drain the fuel from fuel filler pipe.
 - b. Disconnect the fuel filler hose from the fuel filler pipe.
 - c. Insert a suitable hose into the fuel tank through the fuel filler hose to drain the fuel from the fuel tank.
3. Release the fuel pressure from the fuel lines. Refer to [EC-500. "Fuel Pressure Check"](#).
 4. Disconnect the battery negative terminal.
 5. Disconnect the lower fuel filler hose from the fuel tank, the EVAP hose, and the vent pipe quick connector.
 - Disconnect the fuel feed hose from the molded clip in the side of the fuel tank.Disconnect the quick connector as follows:
 - Hold the sides of the connector, push in the tabs and pull out the tube.
 - If the connector and the tube are stuck together, push and pull several times until they start to move. Then disconnect them by pulling.

CAUTION:

- The quick connector can be disconnected when the tabs are completely depressed. Do not twist the quick connector more than necessary.
- Do not use any tools to disconnect the quick connector.
- Keep the resin tube away from heat. Be especially careful when welding near the tube.
- Prevent any acid liquids such as battery electrolyte, from getting on the resin tube.
- Do not bend or twist the resin tube during connection.
- Do not remove the remaining retainer on the hard tube (or the equivalent) except when the resin tube or the retainer is replaced.
- When the resin tube or hard tube, or the equivalent, is replaced, also replace the retainer with a new one (semi-transparent colored retainer).

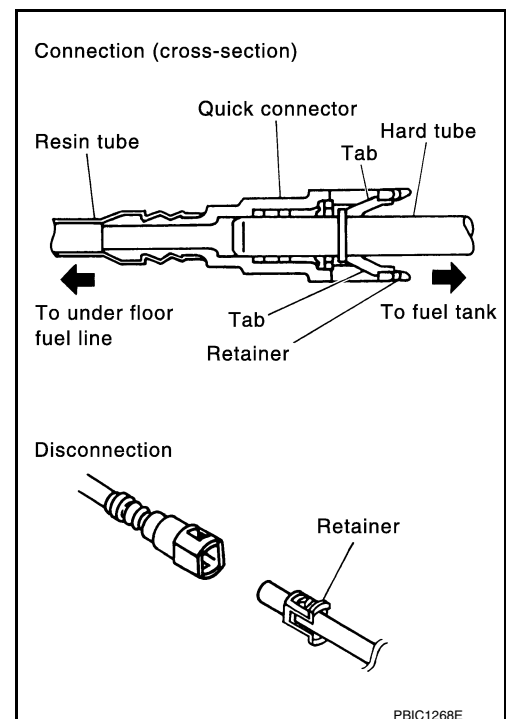
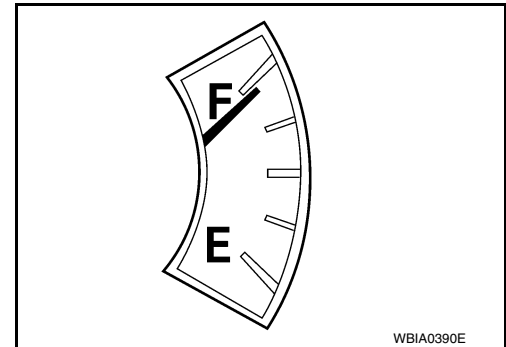

FUEL TANK

< ON-VEHICLE REPAIR >

- To keep the quick connector clean and to avoid damage and contamination from foreign materials, cover the quick connector with plastic bags or suitable material as shown.

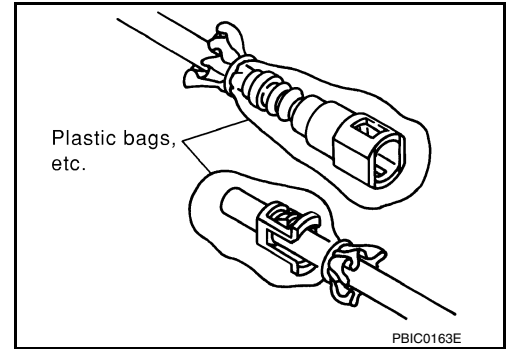

6. Remove the four bolts and remove the fuel tank shield.
7. Remove the propeller shaft. Refer to [DLN-142, "Removal and Installation"](#) (2S1330).
8. Support the fuel tank using a suitable lift jack.
9. Remove the three fuel tank strap bolts while supporting the fuel tank with a suitable lift jack.

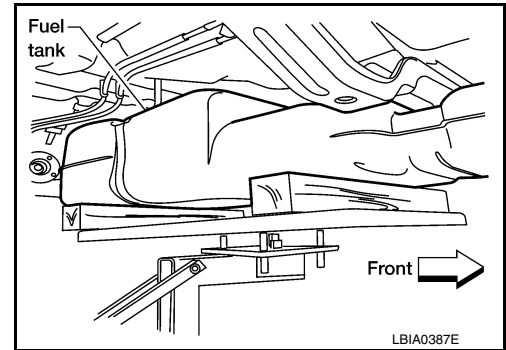

10. Remove the fuel tank straps and slowly lower the fuel tank to access the top of the fuel level sensor, fuel filter and fuel pump assembly.

CAUTION:

Do not lower the fuel tank too far to prevent damage to the fuel feed hose and the fuel level sensor, fuel filter and fuel pump assembly connector.

11. Disconnect the fuel level sensor, fuel filter, and fuel pump assembly electrical connector, and the fuel feed hose.

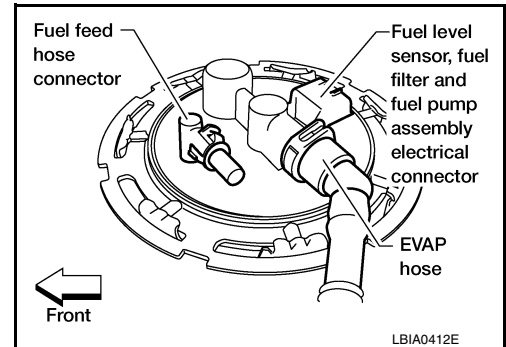

Disconnect the quick connector as follows:

- Hold the sides of the connector, push in the tabs and pull out the tube.
- If the connector and the tube are stuck together, push and pull several times until they start to move. Then disconnect them by pulling.

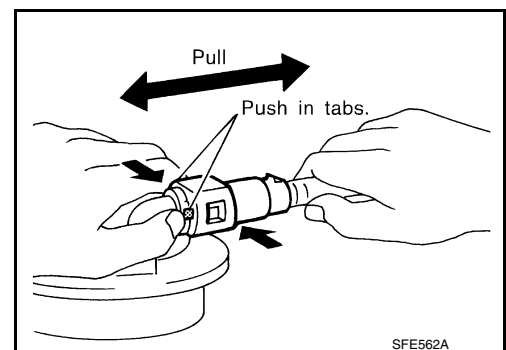

CAUTION:

FUEL TANK

< ON-VEHICLE REPAIR >

- The quick connector can be disconnected when the tabs are completely depressed. Do not twist the quick connector more than necessary.
- Do not use any tools to disconnect the quick connector.
- Keep the resin tube away from heat. Be especially careful when welding near the tube.
- Prevent any acid liquids such as battery electrolyte, from getting on the resin tube.
- Do not bend or twist the resin tube during connection.
- Do not remove the remaining retainer on the hard tube (or the equivalent) except when the resin tube or the retainer is replaced.
- When the resin tube or hard tube, or the equivalent, is replaced, also replace the retainer with a new one (semi-transparent colored retainer).

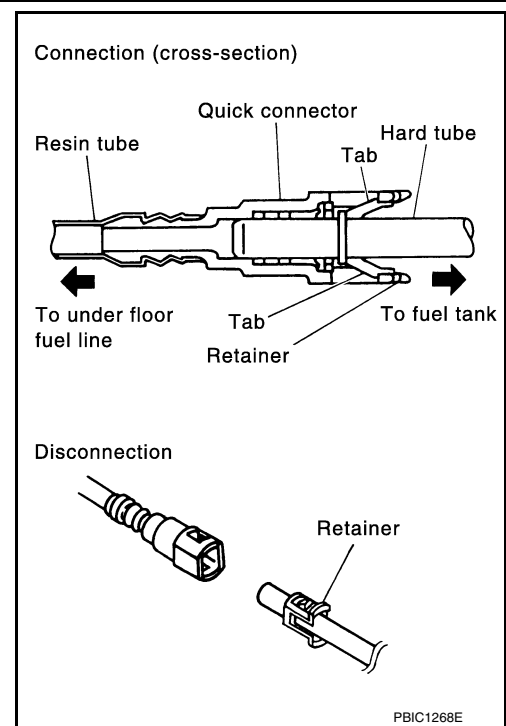

- To keep the quick connector clean and to avoid damage and contamination from foreign materials, cover the quick connector with plastic bags or suitable material as shown.

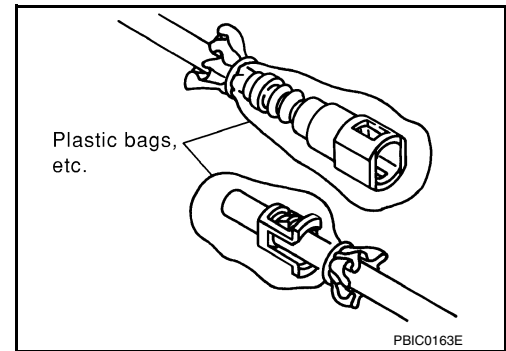

12. Lower the fuel tank using a suitable lift jack and remove the fuel tank.
13. Disconnect the EVAP hose from the fuel pump and remove the EVAP hose from the molded clip in the top of the fuel tank.
14. Remove the lock ring using Tool.

Tool number : — (J-45722)

15. Remove the fuel level sensor, fuel filter, and fuel pump assembly.

CAUTION:

- Do not bend the float arm during removal.
- Avoid impacts such as dropping when handling the components.

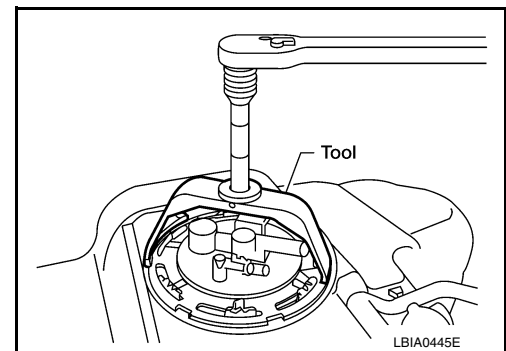

INSTALLATION

Installation is in the reverse order of removal.

- Connect the quick connector as follows:
 - Check the connection for any damage or foreign materials.
 - Align the connector with the pipe, then insert the connector straight into the pipe until a click is heard.

FUEL TANK

< ON-VEHICLE REPAIR >

- After connecting the quick connector, make sure that the connection is secure by checking as follows:
- Pull the tube and the connector to make sure they are securely connected.
- Visually inspect the connector to make sure the two retainer tabs are securely connected.
- Perform adjustment of steering angle sensor neutral position. Refer to [BRC-12. "ADJUSTMENT OF STEERING ANGLE SENSOR NEUTRAL POSITION : Special Repair Requirement"](#) (Type 1), [BRC-123. "ADJUSTMENT OF STEERING ANGLE SENSOR NEUTRAL POSITION : Special Repair Requirement"](#) (Type 2).

CAUTION:

- **Do not bend the float arm during installation.**
- **Avoid impacts such as dropping when handling the components.**

INSPECTION AFTER INSTALLATION

1. Turn the ignition switch ON but do not start engine, then check the fuel pipe and hose connections for leaks while applying fuel pressure.
2. Start the engine and rev it above idle, then check that there are no fuel leaks at any of the fuel pipe and hose connections.

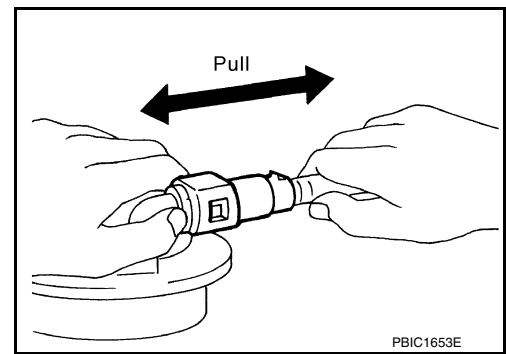

FUEL LEVEL SENSOR UNIT, FUEL FILTER AND FUEL PUMP ASSEMBLY

< ON-VEHICLE REPAIR >

FUEL LEVEL SENSOR UNIT, FUEL FILTER AND FUEL PUMP ASSEMBLY

Removal and Installation

INFOID:000000005269043

SEC. 172

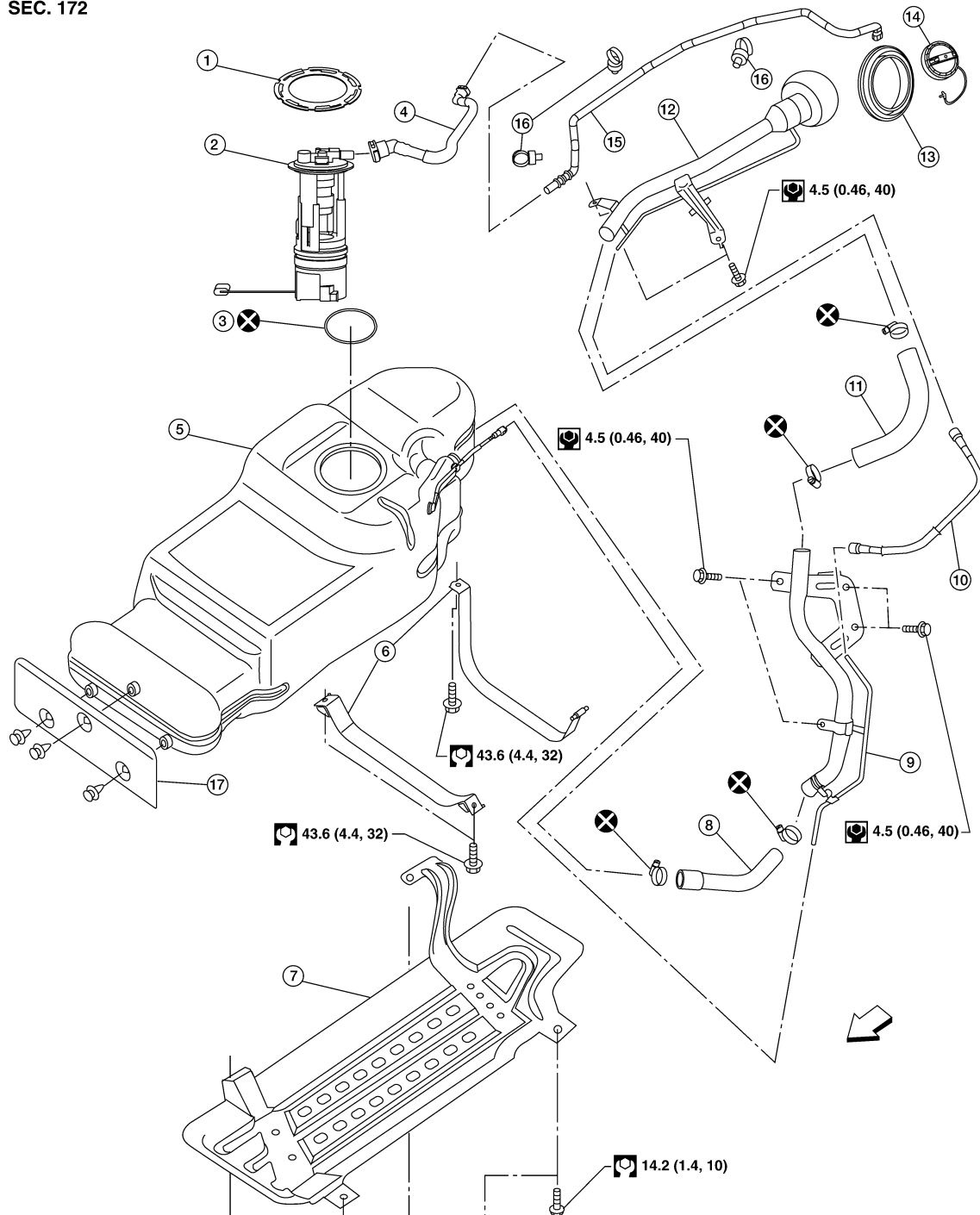

AWBIA0874GB

- | | | |
|------------------------------|---|--|
| 1. Lock ring | 2. Fuel level sensor, fuel filter, and fuel pump assembly | 3. Fuel level sensor, fuel filter, and fuel pump assembly O-ring |
| 4. EVAP hose | 5. Fuel tank | 6. Fuel tank straps |
| 7. Fuel tank shield | 8. Lower fuel filler hose | 9. Fuel filler pipe and vent pipe |
| 10. Vent hose | 11. Upper fuel filler hose | 12. Fuel filler pipe and cup |
| 13. Fuel filler hose grommet | 14. Fuel filler cap | 15. EVAP Canister hose |
| 16. Clip | 17. Fuel tank protector | ← Front |

A
FL
C
D
E
F
G
H
I
J
K
L
M
N
O
P

FUEL LEVEL SENSOR UNIT, FUEL FILTER AND FUEL PUMP ASSEMBLY

< ON-VEHICLE REPAIR >

REMOVAL

WARNING:

Follow the "General Precautions" before working on the fuel system. Refer to [FL-2, "General Precaution"](#).

1. Remove the fuel filler cap to release the pressure from inside the fuel tank.

2. Check the fuel level on level gauge. If the fuel gauge indicates more than the level as shown (full or almost full), drain the fuel from the fuel tank until the fuel gauge indicates the level as shown, or less.

NOTE:

Fuel will be spilled when removing the fuel level sensor, fuel filter, and fuel pump assembly for the fuel level is above the fuel level sensor, fuel filter, and fuel pump assembly fuel tank opening.

- As a guide, the fuel level reaches the fuel gauge position as shown, or less, when approximately 15 ℓ (4 US gal, 3 1/4 Imp gal) of fuel are drained from the fuel tank.

- If the fuel pump does not operate, use the following procedure to drain the fuel to the specified level.

a. Insert a suitable hose of less than 15 mm (0.59 in) diameter into the fuel filler pipe through the fuel filler opening to drain the fuel from fuel filler pipe.

b. Disconnect the fuel filler hose from the fuel filler pipe.

c. Insert a suitable hose into the fuel tank through the fuel filler hose to drain the fuel from the fuel tank.

3. Release the fuel pressure from the fuel lines. Refer to [EC-500, "Fuel Pressure Check"](#).

4. Disconnect the battery negative terminal.

5. Disconnect the lower fuel filler hose from the fuel tank, the EVAP hose, and the vent pipe quick connector.

- Disconnect the fuel feed hose from the molded clip in the side of the fuel tank.

Disconnect the quick connector as follows:

- Hold the sides of the connector, push in the tabs and pull out the tube.

- If the connector and the tube are stuck together, push and pull several times until they start to move. Then disconnect them by pulling.

CAUTION:

- The quick connector can be disconnected when the tabs are completely depressed. Do not twist the quick connector more than necessary.

- Do not use any tools to disconnect the quick connector.

- Keep the resin tube away from heat. Be especially careful when welding near the tube.

- Prevent any acid liquids such as battery electrolyte, from getting on the resin tube.

- Do not bend or twist the resin tube during connection.

- Do not remove the remaining retainer on the hard tube (or the equivalent) except when the resin tube or the retainer is replaced.

- When the resin tube or hard tube, or the equivalent, is replaced, also replace the retainer with a new one (semi-transparent colored retainer).

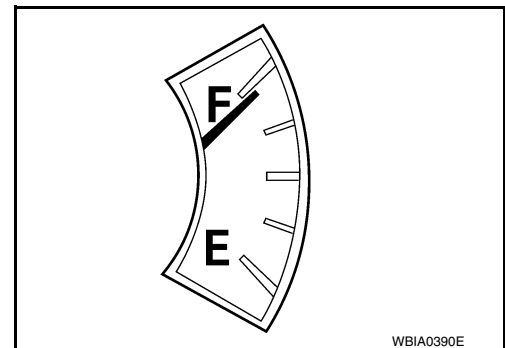

WBIA0390E

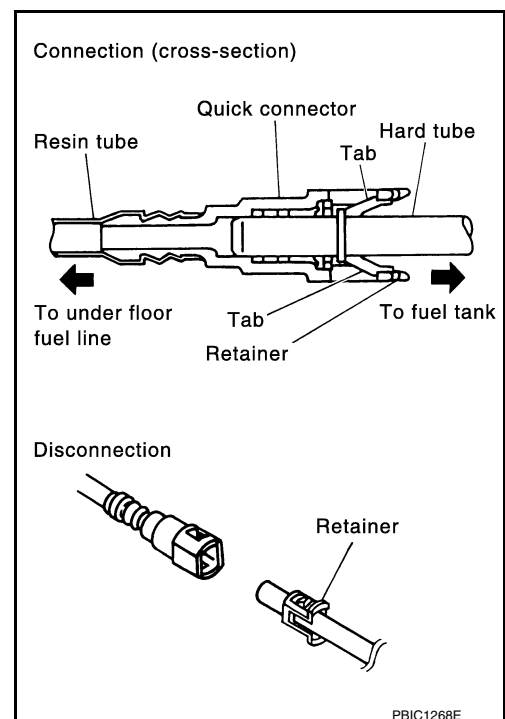

PBIC1268E

FUEL LEVEL SENSOR UNIT, FUEL FILTER AND FUEL PUMP ASSEMBLY

< ON-VEHICLE REPAIR >

- To keep the quick connector clean and to avoid damage and contamination from foreign materials, cover the quick connector with plastic bags or suitable material as shown.

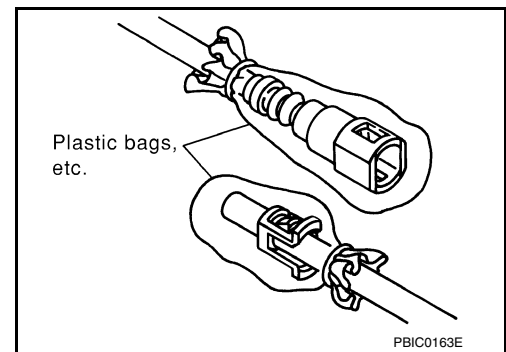

- Remove the four bolts and remove the fuel tank shield.
- Remove the propeller shaft. Refer to [DLN-142, "Removal and Installation"](#) (2S1330).
- Support the fuel tank using a suitable lift jack.
- Remove the three fuel tank strap bolts while supporting the fuel tank with a suitable lift jack.

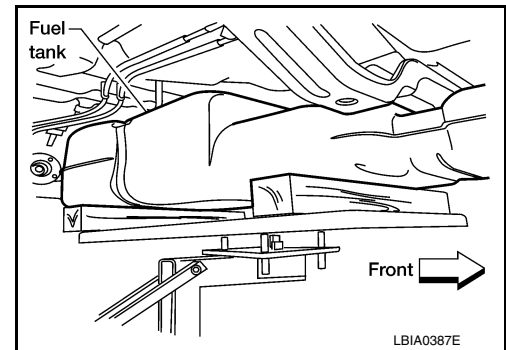

- Remove the fuel tank straps and slowly lower the fuel tank to access the top of the fuel level sensor, fuel filter and fuel pump assembly.

CAUTION:

Do not lower the fuel tank too far to prevent damage to the fuel feed hose and the fuel level sensor, fuel filter and fuel pump assembly connector

- Disconnect the fuel level sensor, fuel filter, and fuel pump assembly electrical connector, and the fuel feed hose.

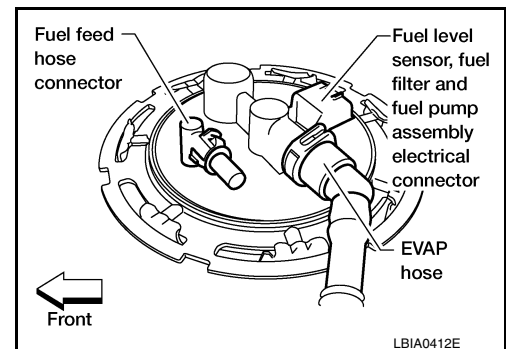

Disconnect the quick connector as follows:

- Hold the sides of the connector, push in the tabs and pull out the tube.
- If the connector and the tube are stuck together, push and pull several times until they start to move. Then disconnect them by pulling.

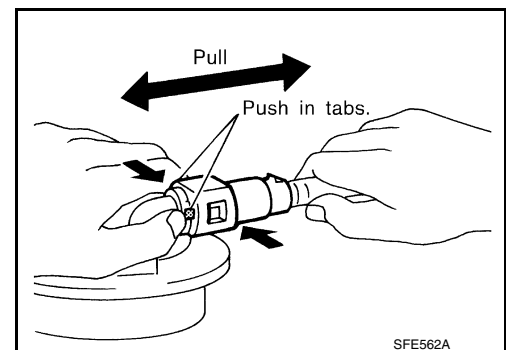

CAUTION:

FUEL LEVEL SENSOR UNIT, FUEL FILTER AND FUEL PUMP ASSEMBLY

< ON-VEHICLE REPAIR >

- The quick connector can be disconnected when the tabs are completely depressed. Do not twist the quick connector more than necessary.
- Do not use any tools to disconnect the quick connector.
- Keep the resin tube away from heat. Be especially careful when welding near the tube.
- Prevent any acid liquids such as battery electrolyte, from getting on the resin tube.
- Do not bend or twist the resin tube during connection.
- Do not remove the remaining retainer on the hard tube (or the equivalent) except when the resin tube or the retainer is replaced.
- When the resin tube or hard tube, or the equivalent, is replaced, also replace the retainer with a new one (semi-transparent colored retainer).

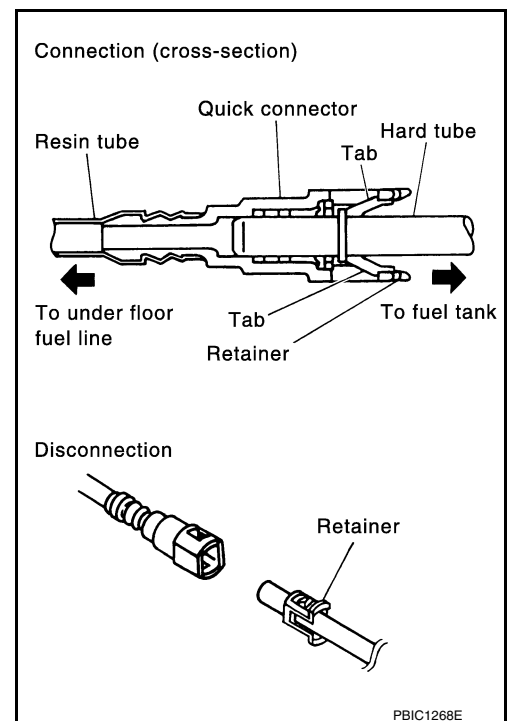

- To keep the quick connector clean and to avoid damage and contamination from foreign materials, cover the quick connector with plastic bags or suitable material as shown.

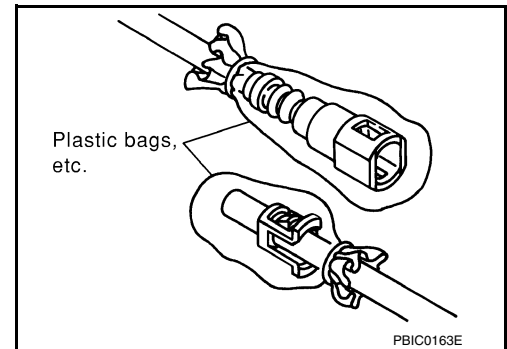

12. Lower the fuel tank using a suitable lift jack and remove the fuel tank.
13. Disconnect the EVAP hose from the fuel pump and remove the EVAP hose from the molded clip in the top of the fuel tank.
14. Remove the lock ring using Tool.

Tool number : — (J-45722)

15. Remove the fuel level sensor, fuel filter, and fuel pump assembly.

CAUTION:

- Do not bend the float arm during removal.
- Avoid impacts such as dropping when handling the components.

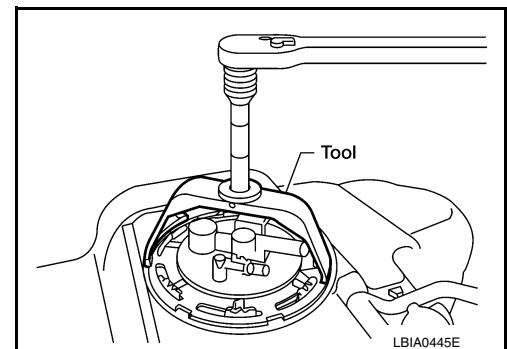

INSTALLATION

Installation is in the reverse order of removal.

- Connect the quick connector as follows:
 - Check the connection for any damage or foreign materials.
 - Align the connector with the pipe, then insert the connector straight into the pipe until a click is heard.

FUEL LEVEL SENSOR UNIT, FUEL FILTER AND FUEL PUMP ASSEMBLY

< ON-VEHICLE REPAIR >

- After connecting the quick connector, make sure that the connection is secure by checking as follows:
- Pull the tube and the connector to make sure they are securely connected.
- Visually inspect the connector to make sure the two retainer tabs are securely connected.
- Perform adjustment of steering angle sensor neutral position. Refer to [BRC-12. "ADJUSTMENT OF STEERING ANGLE SENSOR NEUTRAL POSITION : Special Repair Requirement"](#) (Type 1), [BRC-123. "ADJUSTMENT OF STEERING ANGLE SENSOR NEUTRAL POSITION : Special Repair Requirement"](#) (Type 2).

CAUTION:

- **Do not bend the float arm during installation.**
- **Avoid impacts such as dropping when handling the components.**

INSPECTION AFTER INSTALLATION

1. Turn the ignition switch ON but do not start engine, then check the fuel pipe and hose connections for leaks while applying fuel pressure.
2. Start the engine and rev it above idle, then check that there are no fuel leaks at any of the fuel pipe and hose connections.

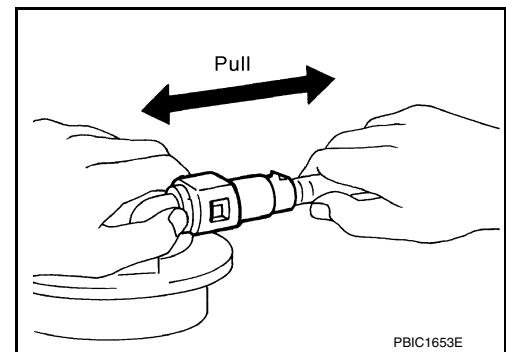

A

FL

C

D

E

F

G

H

I

J

K

L

M

N

O

P

FUEL LEVEL SENSOR UNIT, FUEL FILTER AND FUEL PUMP ASSEMBLY

< DISASSEMBLY AND ASSEMBLY >

DISASSEMBLY AND ASSEMBLY

FUEL LEVEL SENSOR UNIT, FUEL FILTER AND FUEL PUMP ASSEMBLY

Disassembly and Assembly

INFOID:000000005269044

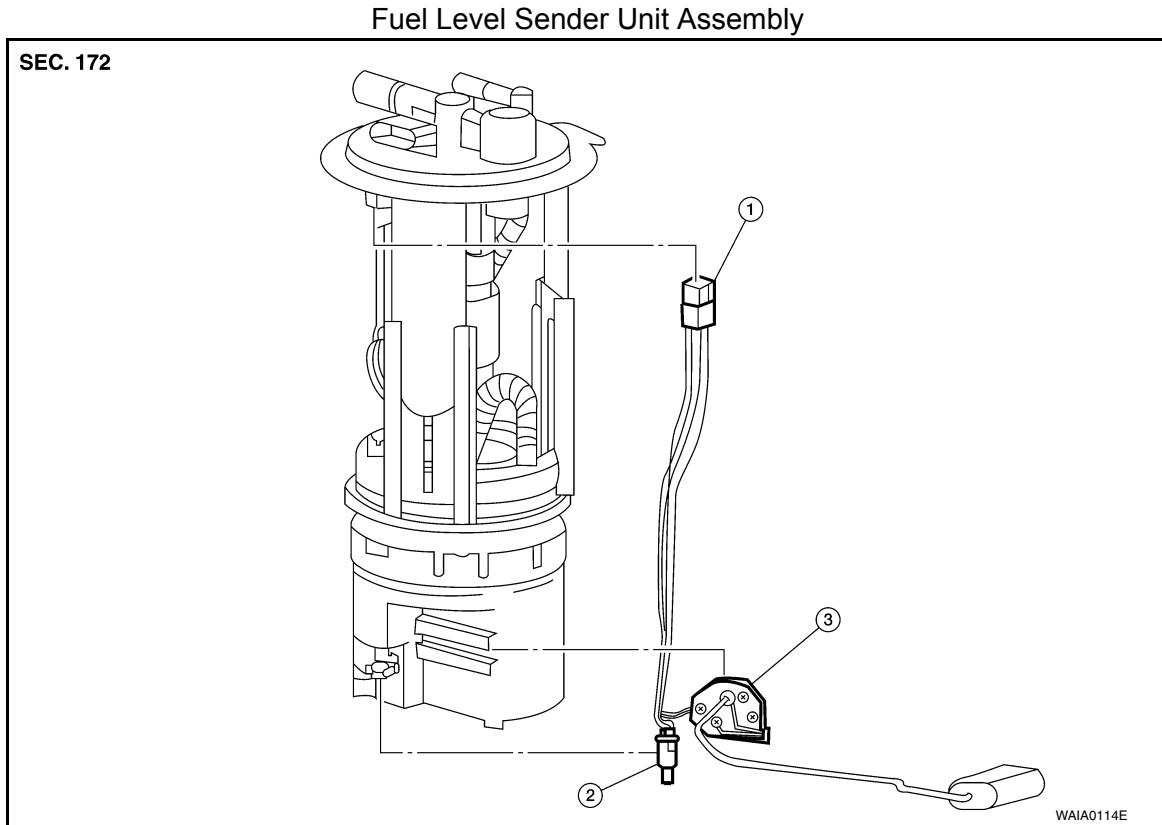

1. Harness connector

2. Fuel sensor

3. Fuel level sender unit assembly

Disassembly

1. Disconnect the harness connector.
2. Remove the fuel sensor.
3. Remove the fuel level sender unit assembly.

Assembly

Assembly is in the reverse order of disassembly.

SERVICE DATA AND SPECIFICATIONS (SDS)

< SERVICE DATA AND SPECIFICATIONS (SDS)

SERVICE DATA AND SPECIFICATIONS (SDS)

SERVICE DATA AND SPECIFICATIONS (SDS)

Standard and Limit

INFOID:000000005269045

A

FL

Fuel tank capacity	80 ℓ (21 1/8 US gal, 17 5/8 Imp gal)
--------------------	--------------------------------------

C

D

E

F

G

H

I

J

K

L

M

N

O

P