

SECTION **HA**

HEATER & AIR CONDITIONING SYSTEM

CONTENTS

PRECAUTION	3	ELECTRICAL LEAK DETECTOR	22	A
PRECAUTIONS	3	Checking of Refrigerant Leaks	22	B
Precaution for Supplemental Restraint System (SRS) "AIR BAG" and "SEAT BELT PRE-TEN- SIONER"	3	Electronic Refrigerant Leak Detector	22	C
Precaution for Working with HFC-134a (R-134a).....	3	ON-VEHICLE REPAIR	25	D
Contaminated Refrigerant	4	REFRIGERATION SYSTEM	25	E
General Refrigerant Precaution	4	Component	25	F
Precaution for Leak Detection Dye	4	HFC-134a (R-134a) Service Procedure	27	G
A/C Identification Label	5	COMPRESSOR	28	H
Precaution for Refrigerant Connection	5	Removal and Installation for Compressor	28	HA
Precaution for Service of Compressor	8	Removal and Installation for Compressor Clutch	29	
Precaution for Service Equipment	8	HIGH-PRESSURE FLEXIBLE HOSE	32	J
PREPARATION	11	Removal and Installation for Front High-pressure Flexible A/C Hose	32	K
PREPARATION	11	HIGH-PRESSURE PIPE	33	L
Special Service Tool	11	Removal and Installation for Front High-pressure A/C Pipe	33	M
HFC-134a (R-134a) Service Tool and Equipment... ..	11	LOW-PRESSURE FLEXIBLE HOSE	34	N
Commercial Service Tool	14	Removal and Installation for Front Low-Pressure Flexible A/C Hose	34	O
FUNCTION DIAGNOSIS	15	LOW-PRESSURE PIPE	35	P
REFRIGERATION SYSTEM	15	Removal and Installation for Front Low-Pressure A/C Pipe	35	
Refrigerant Cycle	15	CONDENSER	36	
Refrigerant System Protection	15	Removal and Installation for Condenser	36	
ON-VEHICLE MAINTENANCE	16	REFRIGERANT PRESSURE SENSOR	37	
REFRIGERATION SYSTEM	16	Removal and Installation for Refrigerant Pressure Sensor	37	
HFC-134a (R-134a) Service Procedure	16	EXPANSION VALVE	38	
OIL	18	Removal and Installation for Front Expansion Valve	38	
Maintenance of Oil Quantity in Compressor	18	SERVICE DATA AND SPECIFICATIONS (SDS)	39	
FLUORESCENT LEAK DETECTOR	20			
Checking of Refrigerant Leaks	20			
Checking System for Leaks Using the Fluorescent Dye Leak Detector	20			
Dye Injection	20			

SERVICE DATA AND SPECIFICATIONS
(SDS) 39

Service Data and Specification (SDS) 39

PRECAUTIONS

< PRECAUTION >

PRECAUTION

PRECAUTIONS

Precaution for Supplemental Restraint System (SRS) "AIR BAG" and "SEAT BELT PRE-TENSIONER"

INFOID:000000005550200

The Supplemental Restraint System such as "AIR BAG" and "SEAT BELT PRE-TENSIONER", used along with a front seat belt, helps to reduce the risk or severity of injury to the driver and front passenger for certain types of collision. This system includes seat belt switch inputs and dual stage front air bag modules. The SRS system uses the seat belt switches to determine the front air bag deployment, and may only deploy one front air bag, depending on the severity of a collision and whether the front occupants are belted or unbelted. Information necessary to service the system safely is included in the SR and SB section of this Service Manual.

WARNING:

- To avoid rendering the SRS inoperative, which could increase the risk of personal injury or death in the event of a collision which would result in air bag inflation, all maintenance must be performed by an authorized NISSAN/INFINITI dealer.
- Improper maintenance, including incorrect removal and installation of the SRS, can lead to personal injury caused by unintentional activation of the system. For removal of Spiral Cable and Air Bag Module, see the SR section.
- Do not use electrical test equipment on any circuit related to the SRS unless instructed to in this Service Manual. SRS wiring harnesses can be identified by yellow and/or orange harnesses or harness connectors.

PRECAUTIONS WHEN USING POWER TOOLS (AIR OR ELECTRIC) AND HAMMERS

WARNING:

- When working near the Airbag Diagnosis Sensor Unit or other Airbag System sensors with the Ignition ON or engine running, DO NOT use air or electric power tools or strike near the sensor(s) with a hammer. Heavy vibration could activate the sensor(s) and deploy the air bag(s), possibly causing serious injury.
- When using air or electric power tools or hammers, always switch the Ignition OFF, disconnect the battery, and wait at least 3 minutes before performing any service.

Precaution for Working with HFC-134a (R-134a)

INFOID:000000005267993

WARNING:

- CFC-12 (R-12) refrigerant and HFC-134a (R-134a) refrigerant are not compatible. If the refrigerants are mixed compressor failure is likely to occur. Refer to [HA-4, "Contaminated Refrigerant"](#). To determine the purity of HFC-134a (R-134a) in the vehicle and recovery tank, use refrigerant recovery/recycling equipment and refrigerant identifier.
- Use only specified oil for the HFC-134a (R-134a) A/C system and HFC-134a (R-134a) components. If oil other than that specified is used, compressor failure is likely to occur.
- The specified HFC-134a (R-134a) oil rapidly absorbs moisture from the atmosphere. The following handling precautions must be observed:
 - When removing refrigerant components from a vehicle, immediately cap (seal) the component to minimize the entry of moisture from the atmosphere.
 - When installing refrigerant components to a vehicle, do not remove the caps (unseal) until just before connecting the components. Connect all refrigerant loop components as quickly as possible to minimize the entry of moisture into system.
 - Only use the specified oil from a sealed container. Immediately reseal containers of oil. Without proper sealing, oil will become moisture saturated and should not be used.
 - Avoid breathing A/C refrigerant and oil vapor or mist. Exposure may irritate eyes, nose and throat. Remove HFC-134a (R-134a) from the A/C system using certified service equipment meeting requirements of SAE J2210 [HFC-134a (R-134a) recycling equipment], or SAE J2209 [HFC-134a (R-134a) recovery equipment]. If accidental system discharge occurs, ventilate work area before resuming service. Additional health and safety information may be obtained from refrigerant and oil manufacturers.
- Do not allow the refrigerant oil to come in contact with styrofoam parts. Damage may result.

PRECAUTIONS

< PRECAUTION >

Contaminated Refrigerant

INFOID:000000005267994

If a refrigerant other than pure HFC-134a (R-134a) is identified in a vehicle, your options are:

- Explain to the customer that environmental regulations prohibit the release of contaminated refrigerant into the atmosphere.
- Explain that recovery of the contaminated refrigerant could damage your service equipment and refrigerant supply.
- Suggest the customer return the vehicle to the location of previous service where the contamination may have occurred.
- If you choose to perform the repair, recover the refrigerant using only **dedicated equipment and containers. Do not recover contaminated refrigerant into your existing service equipment.** If your facility does not have dedicated recovery equipment, you may contact a local refrigerant product retailer for available service. This refrigerant must be disposed of in accordance with all federal and local regulations. In addition, replacement of all refrigerant system components on the vehicle is recommended.
- If the vehicle is within the warranty period, the air conditioner warranty is void. Please contact NISSAN Customer Affairs for further assistance.

General Refrigerant Precaution

INFOID:000000005267995

WARNING:

- **Do not release refrigerant into the air. Use approved recovery/recycling equipment to capture the refrigerant every time an air conditioning system is discharged.**
- **Always wear eye and hand protection (goggles and gloves) when working with any refrigerant or air conditioning system.**
- **Do not store or heat refrigerant containers above 52°C (125°F).**
- **Do not heat a refrigerant container with an open flame; if container warming is required, place the bottom of the container in a warm pail of water.**
- **Do not intentionally drop, puncture, or incinerate refrigerant containers.**
- **Keep refrigerant away from open flames: poisonous gas will be produced if refrigerant burns.**
- **Refrigerant will displace oxygen, therefore be certain to work in well ventilated areas to prevent suffocation.**
- **Do not pressure test or leak test HFC-134a (R-134a) service equipment and/or vehicle air conditioning systems with compressed air during repair. Some mixtures of air and HFC-134a (R-134a) have been shown to be combustible at elevated pressures. These mixtures, if ignited, may cause injury or property damage. Additional health and safety information may be obtained from refrigerant manufacturers.**

Precaution for Leak Detection Dye

INFOID:000000005267996

- The A/C system contains a fluorescent leak detection dye used for locating refrigerant leaks. An ultraviolet (UV) lamp is required to illuminate the dye when inspecting for leaks.
- Always wear fluorescence enhancing UV safety goggles to protect your eyes and enhance the visibility of the fluorescent dye.
- The fluorescent dye leak detector is not a replacement for an electronic refrigerant leak detector. The fluorescent dye leak detector should be used in conjunction with an electronic refrigerant leak detector (J-41995).
- For your safety and the customer's satisfaction, read and follow all manufacturer's operating instructions and precautions prior to performing work.
- A compressor shaft seal should not be repaired because of dye seepage. The compressor shaft seal should only be repaired after confirming the leak with an electronic refrigerant leak detector (J-41995).
- Always remove any remaining dye from the leak area after repairs are complete to avoid a misdiagnosis during a future service.
- Do not allow dye to come into contact with painted body panels or interior components. If dye is spilled, clean immediately with the approved dye cleaner. Fluorescent dye left on a surface for an extended period of time **cannot be removed.**
- Do not spray the fluorescent dye cleaning agent on hot surfaces (engine exhaust manifold, etc.).
- Do not use more than one refrigerant dye bottle (1/4 ounce / 7.4 cc) per A/C system.
- Leak detection dyes for HFC-134a (R-134a) and CFC-12 (R-12) A/C systems are different. Do not use HFC-134a (R-134a) leak detection dye in CFC-12 (R-12) A/C systems or CFC-12 (R-12) leak detection dye in HFC-134a (R-134a) A/C systems or A/C system damage may result.
- The fluorescent properties of the dye will remain for over three (3) years unless a compressor failure occurs.

PRECAUTIONS

< PRECAUTION >

A/C Identification Label

INFOID:000000005267997

Vehicles with factory installed fluorescent dye have this identification label on the underside of hood.

Precaution for Refrigerant Connection

INFOID:000000005267998

A new type refrigerant connection has been introduced to all refrigerant lines except the following locations.

- Expansion valve to cooling unit
- Evaporator pipes to evaporator (inside cooling unit)
- Refrigerant pressure sensor

FEATURES OF NEW TYPE REFRIGERANT CONNECTION

- The O-ring has been relocated. It has also been provided with a groove for proper installation. This reduces the possibility of the O-ring being caught in, or damaged by, the mating part. The sealing direction of the O-ring is now set vertically in relation to the contacting surface of the mating part to improve sealing characteristics.
- The reaction force of the O-ring will not occur in the direction that causes the joint to pull out, thereby facilitating piping connections.

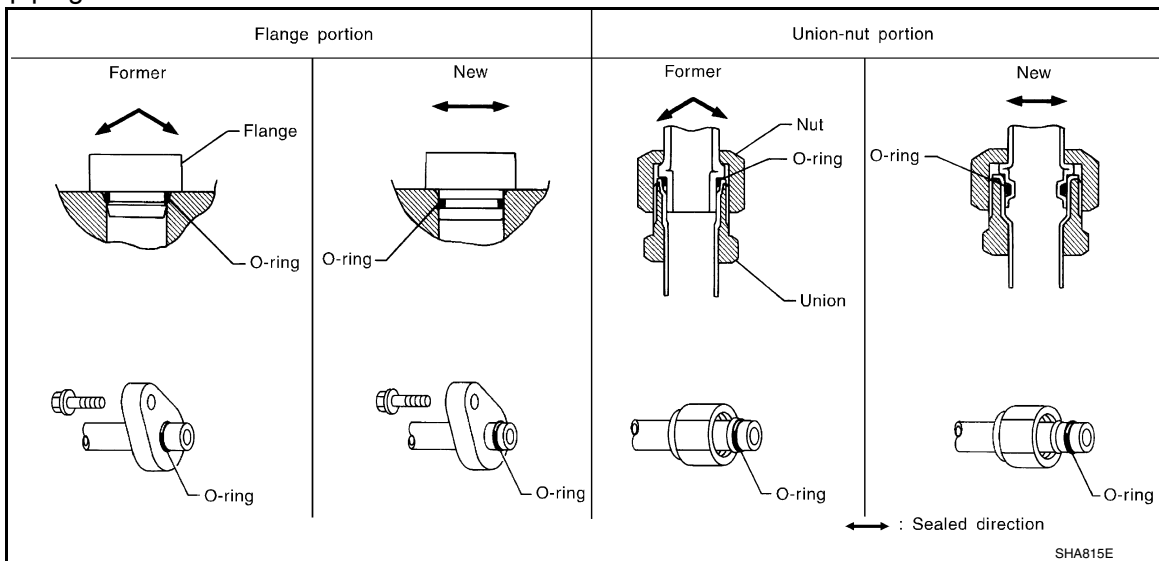

O-RING AND REFRIGERANT CONNECTION

A
B
C
D
E
F
G
H
HA
J
K
L
M
N
O
P

PRECAUTIONS

< PRECAUTION >

Front A/C Compressor and Condenser

SEC. 270 • 271 • 274 • 276 • 278

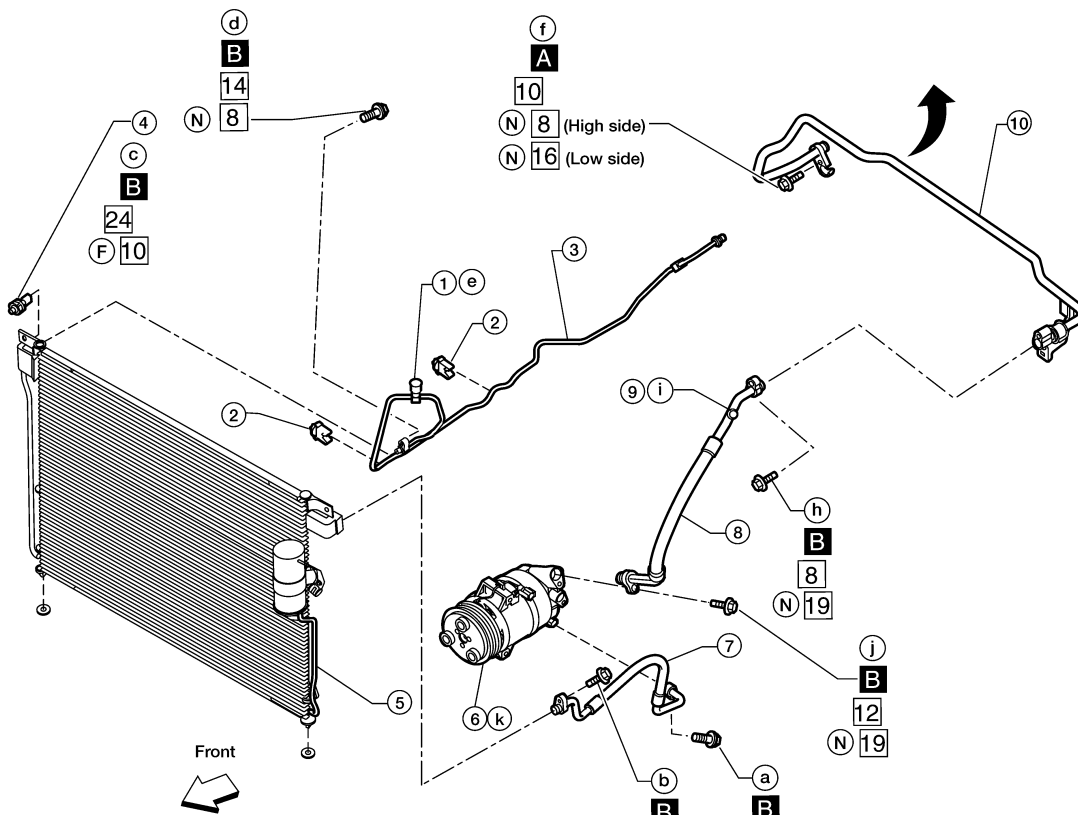
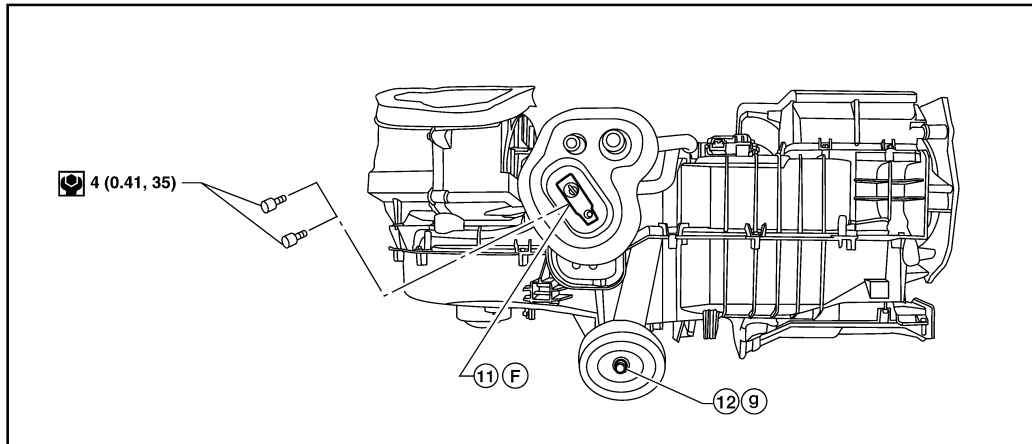

- : Refrigerant leak checking order (a-k)
- : Tightening torque
- : Wrench size
- : O-ring size
- : N·m (kg-m, in-lb)
- A** : 3.4 (0.35, 30)
- B** : 9.3 (0.95, 82)
- F** : Former type refrigerant connection
- N** : New type refrigerant connection

WJIA1481E

- | | | |
|------------------------------------------|-----------------------------------------|---------------------------------|
| 1. High-pressure service valve | 2. Clip | 3. Front high-pressure A/C pipe |
| 4. Refrigerant pressure sensor | 5. Condenser | 6. Compressor shaft seal |
| 7. Front high-pressure flexible A/C hose | 8. Front low-pressure flexible A/C hose | 9. Low-pressure service valve |
| 10. Front low-pressure A/C pipe | 11. Front expansion valve | 12. Front A/C drain hose |

CAUTION:

PRECAUTIONS

< PRECAUTION >

The new and former refrigerant connections use different O-ring configurations. Do not confuse O-rings since they are not interchangeable. If a wrong O-ring is installed, refrigerant will leak at or around the connection.

O-Ring Part Numbers and Specifications

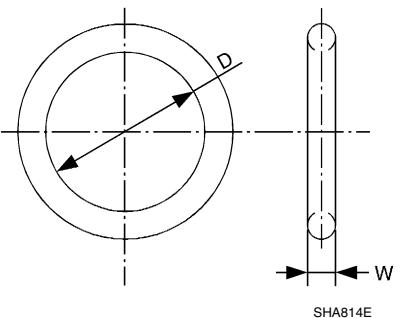
	Conne- tion type	O-ring size	Part number*	D mm (in)	W mm (in)
	New	8	92471 N8210	6.8 (0.268)	1.85 (0.0728)
Former	10	J2476 89956	9.25 (0.3642)	1.78 (0.0701)	
New	12	92472 N8210	10.9 (0.429)	2.43 (0.0957)	
Former		92475 71L00	11.0 (0.433)	2.4 (0.094)	
New	16	92473 N8210	13.6 (0.535)	2.43 (0.0957)	
Former		92475 72L00	14.3 (0.563)	2.3 (0.091)	
New	19	92474 N8210	16.5 (0.650)	2.43 (0.0957)	
Former		92477 N8200	17.12 (0.6740)	1.78 (0.0701)	
New	24	92195 AH300	21.8 (0.858)	2.4 (0.094)	

*: Always check with the Parts Department for the latest parts information.

WARNING:

Make sure all refrigerant is discharged into the recycling equipment and the pressure in the system is less than atmospheric pressure. Then gradually loosen the discharge side hose fitting and remove it.

CAUTION:

When replacing or cleaning refrigerant cycle components, observe the following.

- When the compressor is removed, store it in the same position as it is when mounted on the car. Failure to do so will cause oil to enter the low pressure chamber.
- When connecting tubes, always use a torque wrench and a back-up wrench.
- After disconnecting tubes, immediately plug all openings to prevent entry of dirt and moisture.
- When installing an air conditioner in the vehicle, connect the pipes as the final stage of the operation. Do not remove the seal caps of pipes and other components until just before required for connection.
- Allow components stored in cool areas to warm to working area temperature before removing seal caps. This prevents condensation from forming inside A/C components.
- Thoroughly remove moisture from the refrigeration system before charging the refrigerant.
- Always replace used O-rings.
- When connecting tube, apply oil to circle of the O-rings shown in illustration. Be careful not to apply oil to threaded portion.
Oil name: NISSAN A/C System Oil Type R or equivalent.
- O-ring must be closely attached to dented portion of tube.
- When replacing the O-ring, be careful not to damage O-ring and tube.
- Connect tube until you hear it click, then tighten the nut or bolt by hand until snug. Make sure that the O-ring is installed to tube correctly.
- After connecting line, conduct leak test and make sure that there is no leakage from connections. When the refrigerant leaking point is found, disconnect that line and replace the O-ring. Then tighten connections of seal seat to the specified torque.

PRECAUTIONS

< PRECAUTION >

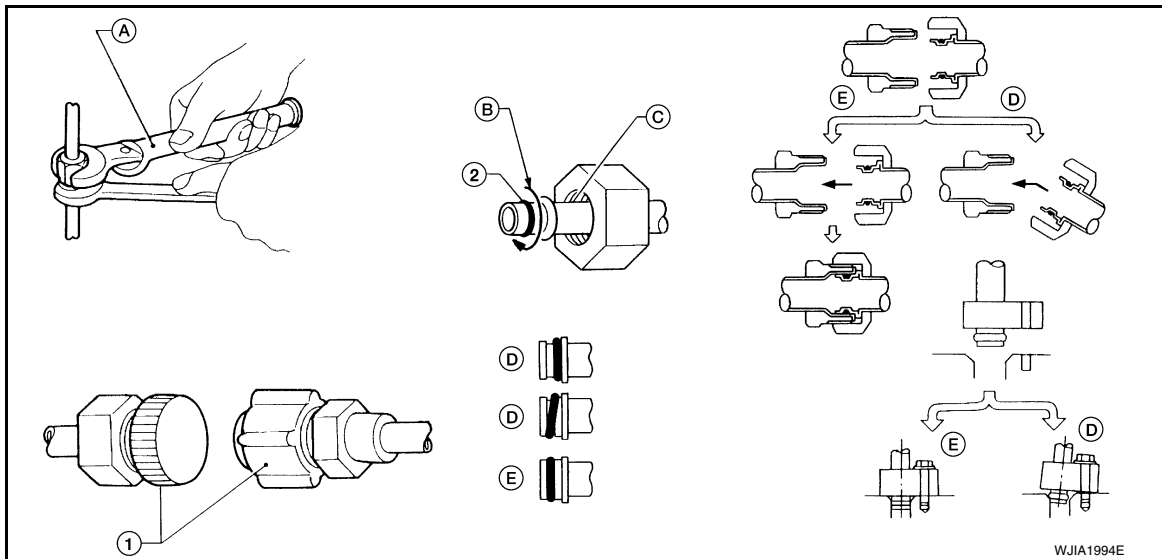

- | | | |
|--------------|-------------------------------|------------------|
| 1. Plug | 2. O-ring | A. Torque wrench |
| B. Apply oil | C. Do not apply oil to thread | D. No good |
| E. Good | | |

Precaution for Service of Compressor

INFOID:000000005267999

- Plug all openings to prevent moisture and foreign matter from entering.
- When the compressor is removed, store it in the same position as it is when mounted on the car.
- When replacing or repairing compressor, follow "Maintenance of Oil Quantity in Compressor" exactly. Refer to [HA-18, "Maintenance of Oil Quantity in Compressor"](#).
- Keep friction surfaces between clutch and pulley clean. If the surface is contaminated with oil, wipe it off by using a clean waste cloth moistened with thinner.
- After compressor service operation, turn the compressor shaft by hand more than 5 turns in both directions. This will equally distribute oil inside the compressor. After the compressor is installed, let the engine idle and operate the compressor for 1 hour.
- After replacing the compressor magnet clutch, apply voltage to the new one and check for normal operation. Refer to [HA-29, "Removal and Installation for Compressor Clutch"](#).

Precaution for Service Equipment

INFOID:000000005268000

RECOVERY/RECYCLING EQUIPMENT

Follow the manufacturer's instructions for machine operation and machine maintenance. Never introduce any refrigerant other than that specified into the machine.

ELECTRONIC LEAK DETECTOR

Follow the manufacturer's instructions for tester operation and tester maintenance.

VACUUM PUMP

PRECAUTIONS

< PRECAUTION >

The oil contained inside the vacuum pump is not compatible with the specified oil for HFC-134a (R-134a) A/C systems. The vent side of the vacuum pump is exposed to atmospheric pressure so the vacuum pump oil may migrate out of the pump into the service hose. This is possible when the pump is switched off after evacuation (vacuuming) and hose is connected to it.

To prevent this migration, use a manual valve situated near the hose-to-pump connection, as follows.

- Usually vacuum pumps have a manual isolator valve as part of the pump. Close this valve to isolate the service hose from the pump.
- For pumps without an isolator, use a hose equipped with a manual shut-off valve near the pump end. Close the valve to isolate the hose from the pump.
- If the hose has an automatic shut off valve, disconnect the hose from the pump: as long as the hose is connected, the valve is open and lubricating oil may migrate.

Some one-way valves open when vacuum is applied and close under a no vacuum condition. Such valves may restrict the pump's ability to pull a deep vacuum and are not recommended.

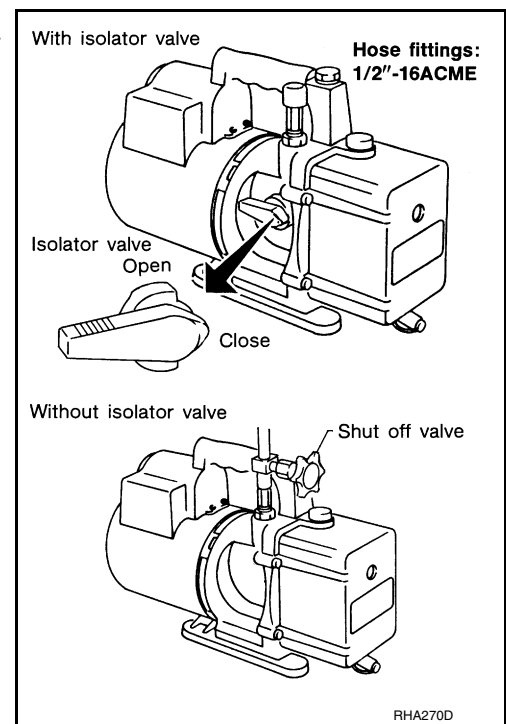

MANIFOLD GAUGE SET

Be certain that the gauge face indicates HFC-134a (R-134a). Make sure the gauge set has 1/2"-16 ACME threaded connections for service hoses. Confirm the set has been used only with refrigerant HFC-134a (R-134a) along with specified oil.

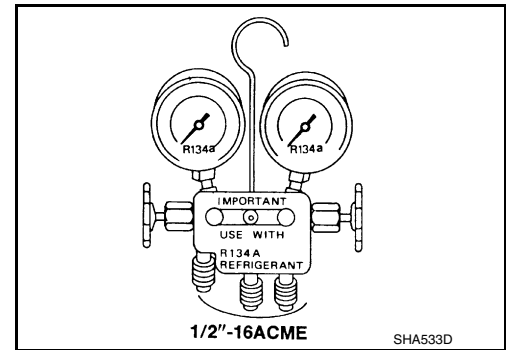

SERVICE HOSES

Be certain that the service hoses display the markings described (colored hose with black stripe). All hoses must include positive shut-off devices (either manual or automatic) near the end of the hoses opposite the manifold gauge.

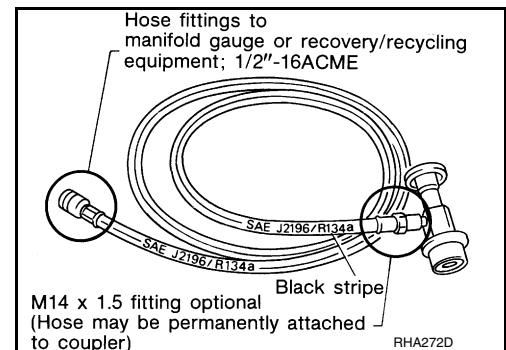

SERVICE COUPLERS

A
B
C
D
E
F
G
H
HA
J
K
L
M
N
O
P

PRECAUTIONS

< PRECAUTION >

Never attempt to connect HFC-134a (R-134a) service couplers to a CFC-12 (R-12) A/C system. The HFC-134a (R-134a) couplers will not properly connect to the CFC-12 (R-12) system. If an improper connection is attempted, discharging and contamination may occur.

Shut-off valve rotation	A/C service valve
Clockwise	Open
Counterclockwise	Close

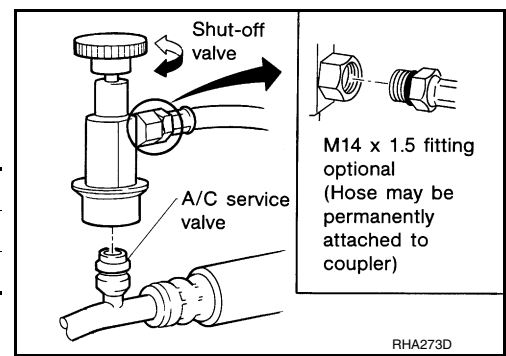

REFRIGERANT WEIGHT SCALE

Verify that no refrigerant other than HFC134a (R-134a) and specified oils have been used with the scale. If the scale controls refrigerant flow electronically, the hose fitting must be 1/2"-16 ACME.

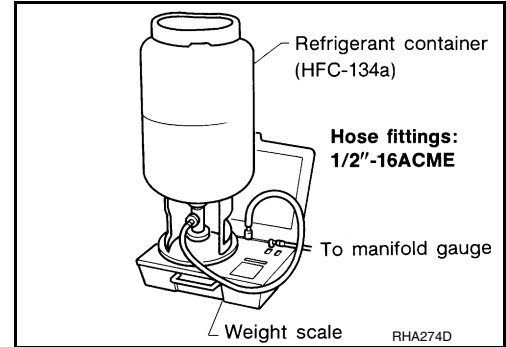

CHARGING CYLINDER

Using a charging cylinder is not recommended. Refrigerant may be vented into air from cylinder's top valve when filling the cylinder with refrigerant. Also, the accuracy of the cylinder is generally less than that of an electronic scale or of quality recycle/recharge equipment.

PREPARATION

< PREPARATION >

PREPARATION

PREPARATION

Special Service Tool

INFOID:000000005268001

The actual shapes of Kent-Moore tools may differ from those of special service tools illustrated here.

Tool number (Kent-Moore No.) Tool name	Description
— (J-41425-NIS) Aluminum tube repair kit	Repairing leaks in A/C tubes
— (J-38873-A) Drive plate installer	Installing pulley
(J-44614) Clutch disc holding tool	Clutch disc holding tool

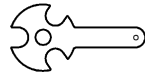
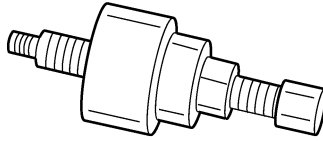
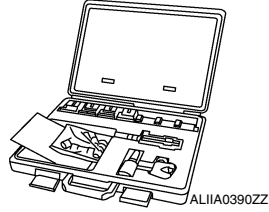

HFC-134a (R-134a) Service Tool and Equipment

INFOID:000000005268002

Never mix HFC-134a (R-134a) refrigerant and/or its specified oil with CFC-12 (R-12) refrigerant and/or its oil. Separate and non-interchangeable service equipment must be used for handling each type of refrigerant/oil. Refrigerant container fittings, service hose fittings and service equipment fittings (equipment which handles refrigerant and/or oil) are different between CFC-12 (R-12) and HFC-134a (R-134a). This is to avoid mixed use of the refrigerants/oil.

Adapters that convert one size fitting to another must never be used refrigerant/oil contamination will occur and compressor failure will result.

PREPARATION

< PREPARATION >

Tool number (Kent-Moore No.) Tool name	Description
HFC-134a (R-134a) (—) Refrigerant	Container color: Light blue Container marking: HFC-134a (R-134a) Fitting size: Thread size • large container 1/2"-16 ACME
— (—) NISSAN A/C System Oil Type R	Type: Poly alkylene glycol oil (PAG), type R Application: HFC-134a (R-134a) vane rotary compressors (NISSAN only) Lubricity: 40 m ℓ (1.4 US fl oz, 1.4 Imp fl oz)
KV991J0130 (ACR2005-NI) ACR A/C Service Center	Refrigerant Recovery and Recycling and Recharging
— (J-41995) Electronic refrigerant leak detector	Power supply: • DC 12V (battery terminal)
— (J-43926) Refrigerant dye leak detection kit Kit includes: (J-42220) UV lamp and UV safety goggles (J-41459) Refrigerant dye injector (J-41447) Fluorescent leak detection dye (box of 24, 1/4 ounce bottles) (J-43872) Refrigerant dye cleaner	Power supply: • DC 12V (battery terminal)
— (J-42220) Fluorescent dye leak detector	Power supply: • DC 12V (battery terminal) For checking refrigerant leak when fluorescent dye is installed in A/C system. Includes: UV lamp and UV safety goggles

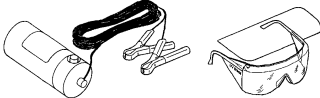
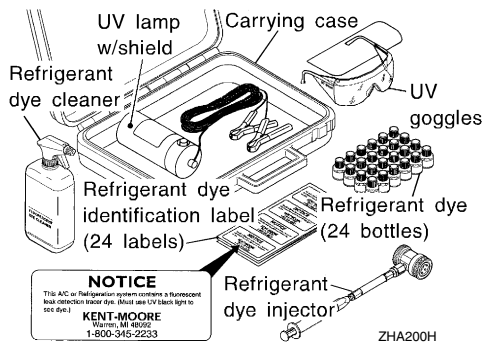
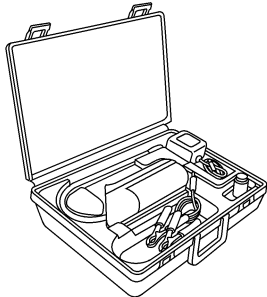
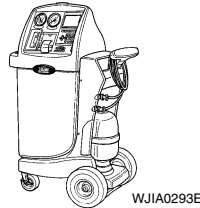
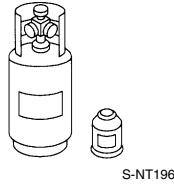

PREPARATION

< PREPARATION >

Tool number (Kent-Moore No.) Tool name	Description	
<p>— (J-41447) HFC-134a (R-134a) Fluorescent leak detection dye (Box of 24, 1/4 ounce bottles)</p>	<p>Application: For HFC-134a (R-134a) PAG oil Container: 1/4 ounce (7.4cc) bottle (Includes self-adhesive dye identifica- tion labels for affixing to vehicle after charging system with dye.)</p>	A B C
<p>— (J-41459) HFC-134a (R-134a) Refrigerant dye injector Use with J-41447, 1/4 ounce bottle</p>	<p>For injecting 1/4 ounce of fluorescent leak detection dye into A/C system.</p>	D E F
<p>— (J-43872) Refrigerant dye cleaner</p>	<p>For cleaning dye spills.</p>	G H
<p>— (J-39183-C) Manifold gauge set (with hoses and couplers)</p>	<p>Identification:</p> <ul style="list-style-type: none"> • The gauge face indicates R-134a. • Fitting size-Thread size • 1/2"-16 ACME 	HA J K L
<p>Service hoses:</p> <ul style="list-style-type: none"> • High side hose (J-39500-72B) • Low side hose (J-39500-72R) • Utility hose (J-39500-72Y) 	<p>Hose color:</p> <ul style="list-style-type: none"> • Low side hose: Blue with black stripe • High side hose: Red with black stripe • Utility hose: Yellow with black stripe or green with black stripe <p>Hose fitting to gauge:</p> <ul style="list-style-type: none"> • 1/2"-16 ACME 	M N
<p>Service couplers</p> <ul style="list-style-type: none"> • High side coupler (J-39500-20A) • Low side coupler (J-39500-24A) 	<p>Hose fitting to service hose:</p> <ul style="list-style-type: none"> • M14 x 1.5 fitting is optional or perma- nently attached. 	O P

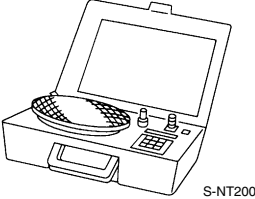
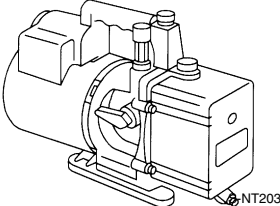

PREPARATION

< PREPARATION >

Tool number (Kent-Moore No.) Tool name	Description
<p>— (J-39699) Refrigerant weight scale</p>  <p style="text-align: right; font-size: small;">S-NT200</p>	<p>For measuring of refrigerant Fitting size-Thread size</p> <ul style="list-style-type: none"> • 1/2"-16 ACME
<p>— (J-39649) Vacuum pump (Including the isolator valve)</p>  <p style="text-align: right; font-size: small;">NT203</p>	<p>Capacity:</p> <ul style="list-style-type: none"> • Air displacement: 4 CFM • Micron rating: 20 microns • Oil capacity: 482 g (17 oz) <p>Fitting size-Thread size</p> <ul style="list-style-type: none"> • 1/2"-16 ACME

Commercial Service Tool

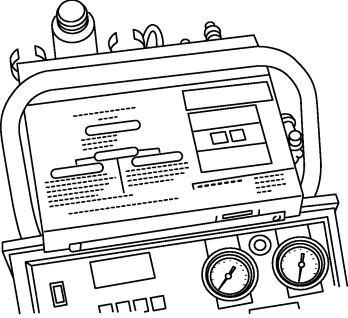
INFOID:000000005268003

Tool name	Description
<p>(J-41810-NI) Refrigerant identifier equipment (R-134a)</p>  <p style="text-align: right; font-size: small;">RJIA0197E</p>	<p>For checking refrigerant purity and system contamination</p>
<p>Power tool</p>  <p style="text-align: right; font-size: small;">PIIB1407E</p>	<p>Loosening bolts and nuts</p>

REFRIGERATION SYSTEM

< FUNCTION DIAGNOSIS >

FUNCTION DIAGNOSIS

REFRIGERATION SYSTEM

Refrigerant Cycle

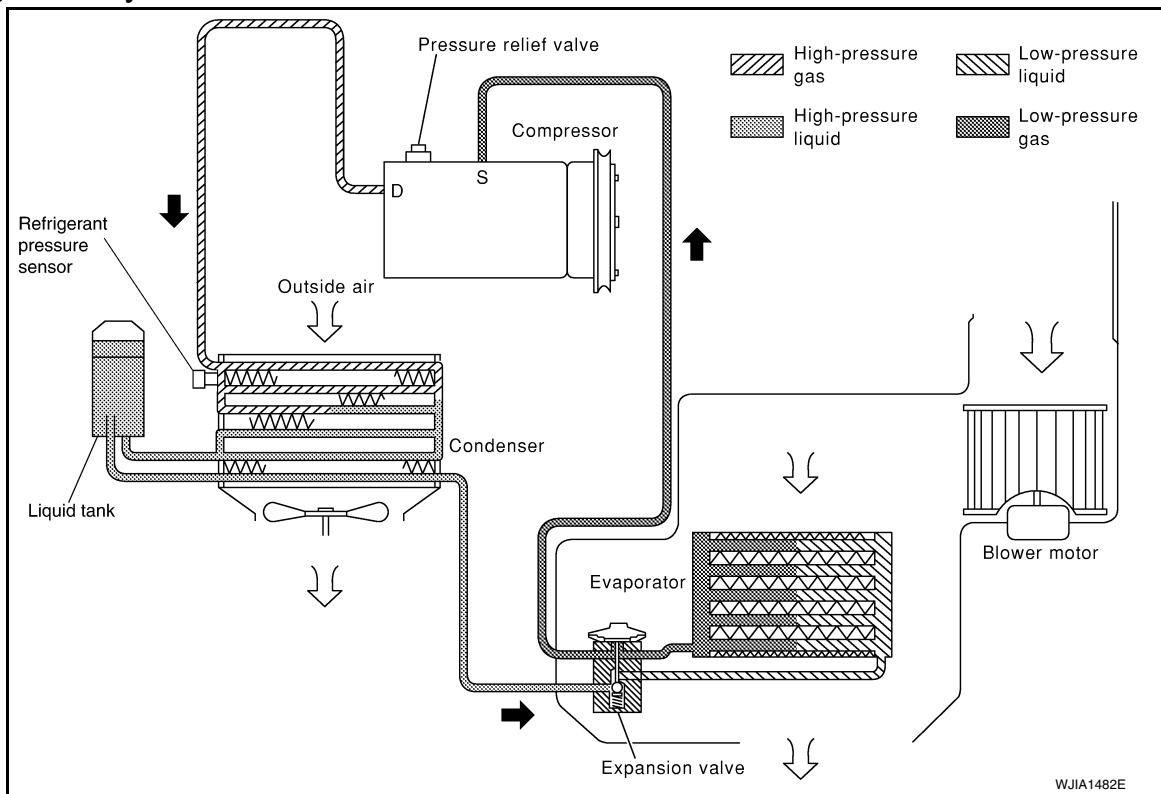

REFRIGERANT FLOW

The refrigerant flows in the standard pattern, that is, through the compressor, the condenser with liquid tank, through the front evaporator, and back to the compressor. The refrigerant evaporation through the evaporator coil is controlled by the front externally equalized expansion valve, located inside the front evaporator case.

FREEZE PROTECTION

The compressor cycles on and off to maintain the evaporator temperature within a specified range. When the evaporator coil temperature falls below a specified point, the intake sensor interrupts the compressor operation. When the evaporator coil temperature rises above the specification, the intake sensor allows compressor operation.

Refrigerant System Protection

REFRIGERANT PRESSURE SENSOR

The refrigerant system is protected against excessively high- or low-pressures by the refrigerant pressure sensor, located on the condenser. If the system pressure rises above or falls below the specifications, the refrigerant pressure sensor detects the pressure inside the refrigerant line and sends a voltage signal to the ECM. The ECM de-energizes the A/C relay to disengage the magnetic compressor clutch when pressure on the high pressure side detected by refrigerant pressure sensor is over about 2,746 kPa (28 kg/cm², 398 psi), or below about 120 kPa (1.22 kg/cm², 17.4 psi).

PRESSURE RELIEF VALVE

The refrigerant system is also protected by a pressure relief valve, located in the rear head of the compressor. When the pressure of refrigerant in the system increases to an abnormal level [more than 2,990 kPa (30.5 kg/cm², 433.6 psi)], the release port on the pressure relief valve automatically opens and releases refrigerant into the atmosphere.

REFRIGERATION SYSTEM

< ON-VEHICLE MAINTENANCE >

ON-VEHICLE MAINTENANCE

REFRIGERATION SYSTEM

HFC-134a (R-134a) Service Procedure

INFOID:000000005268008

SETTING OF SERVICE TOOLS AND EQUIPMENT

Discharging Refrigerant

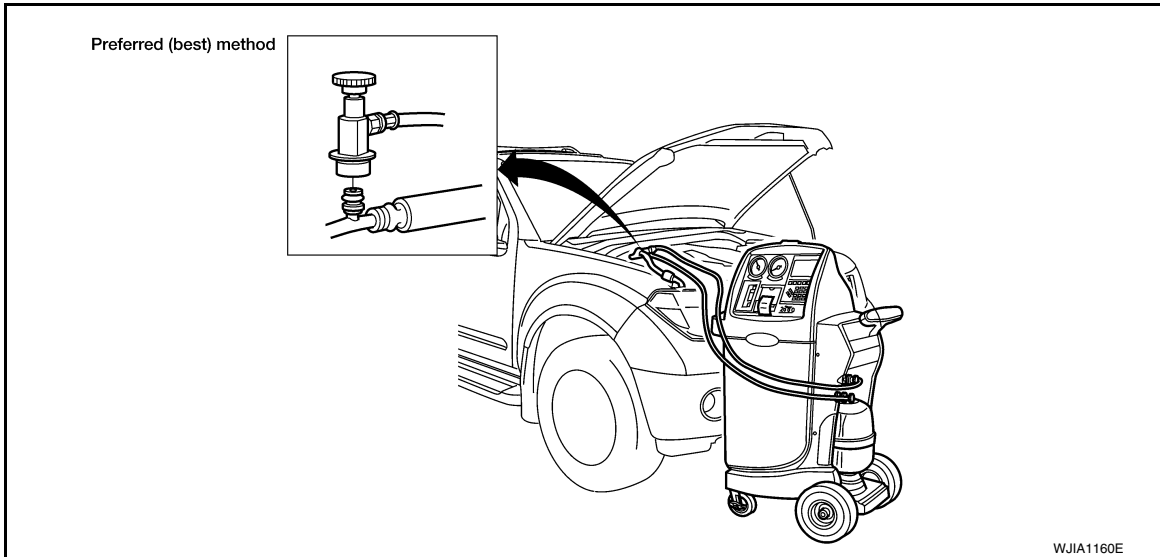

1. Shut-off valve

2. A/C service valve

3. Recovery/recycling equipment

WARNING:

Avoid breathing A/C refrigerant and oil vapor or mist. Exposure may irritate eyes, nose and throat. Remove HFC-134a (R-134a) refrigerant from the A/C system using certified service equipment meeting requirements of SAE J2210 HFC-134a (R-134a) recycling equipment or SAE J2201 HFC-134a (R-134a) recovery equipment. If an accidental system discharge occurs, ventilate the work area before resuming service. Additional health and safety information may be obtained from the refrigerant and oil manufacturers.

Evacuating System and Charging Refrigerant

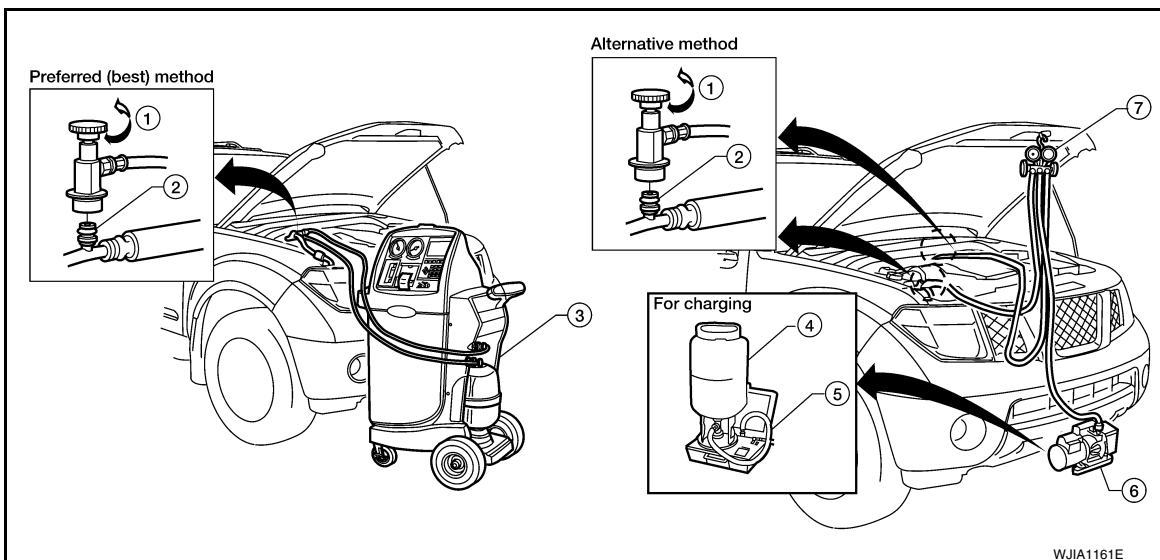

REFRIGERATION SYSTEM

< ON-VEHICLE MAINTENANCE >

1. Shut-off valve
2. A/C service valve
3. Recovery/recycling equipment
4. Refrigerant container (HFC-134a)
5. Refrigerant weight scale (J-39699)
6. Vacuum pump (J-39649)
7. Manifold gauge set with hoses and couplers (J-39183-C)

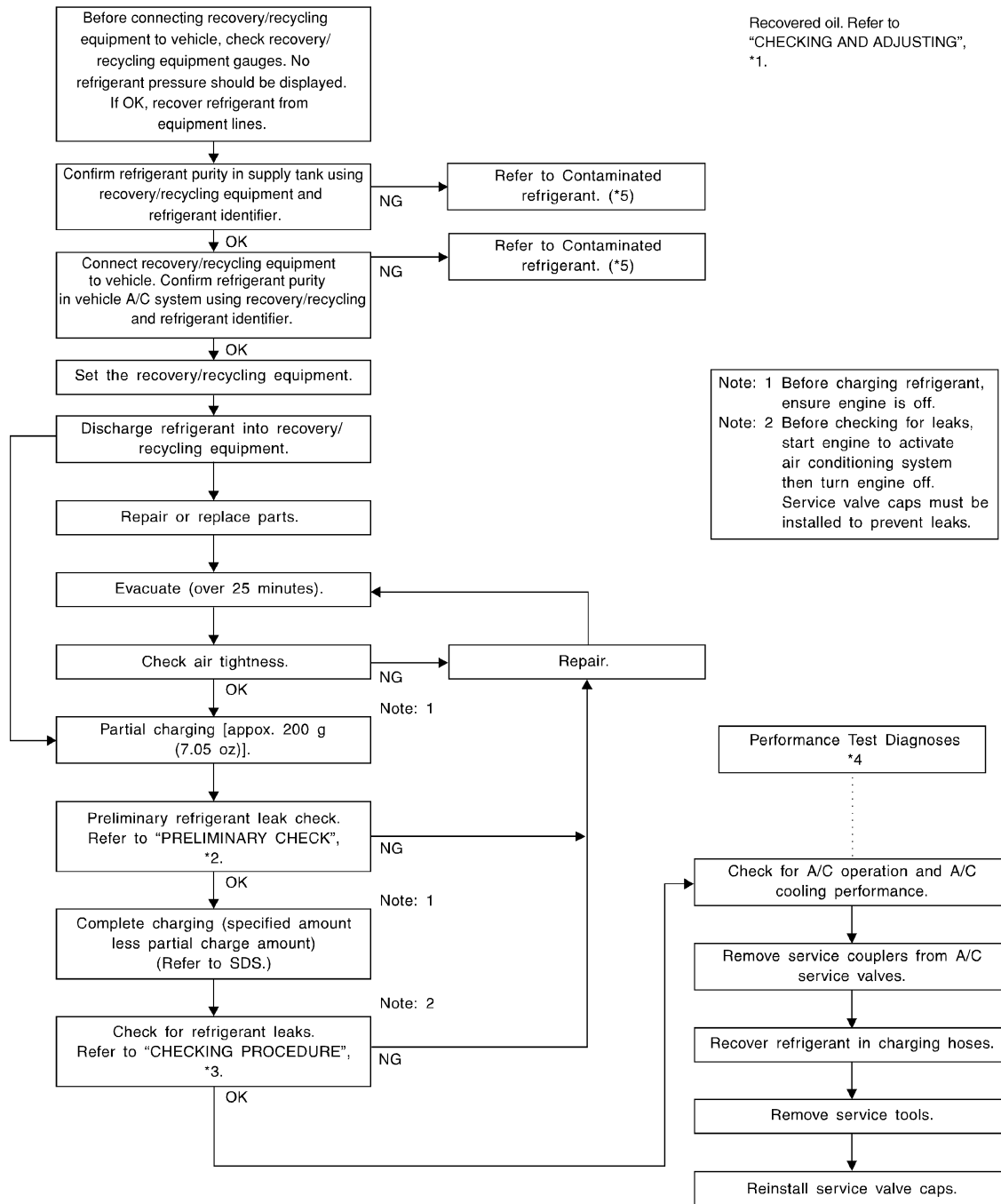

*1 [HA-16. "HFC-134a \(R-134a\) Service Procedure"](#).

*2 [HA-20. "Checking of Refrigerant Leaks"](#).

*3 [HA-20. "Checking of Refrigerant Leaks"](#).

*4 [HAC-6. "Operational Check"](#).

*5 [HA-4. "Contaminated Refrigerant"](#).

WJIA1923E

OIL

< ON-VEHICLE MAINTENANCE >

OIL

Maintenance of Oil Quantity in Compressor

INFOID:000000005268009

The oil in the compressor circulates through the system with the refrigerant. Add oil to compressor when replacing any component or after a large refrigerant leakage has occurred. It is important to maintain the specified amount.

If oil quantity is not maintained properly, the following malfunctions may result:

- Lack of oil: May lead to a seized compressor
- Excessive oil: Inadequate cooling (thermal exchange interference)

OIL

Oil name: NISSAN A/C System Oil Type R or equivalent

CHECKING AND ADJUSTING

CAUTION:

If excessive oil leakage is noted, do not perform the oil return operation.

Start the engine and set the following conditions:

Test Conditions

- **Engine speed: idling to 1,200 rpm**
- **A/C switch: ON**
- **Blower fan speed: HIGH**
- **Temperature control: optional [set so intake air temperature is 25° to 30° C (77° to 86°F)]**
- **Intake position: RECIRCULATION mode**
- **Perform oil return operation for about ten minutes**

Adjust the oil quantity according to the following table.

Oil Adjusting Procedure for Components Replacement Except Compressor

After replacing any of the following major components, add the correct amount of oil to the system.

Amount of Oil to be Added

Part replaced	Oil to be added to system	Remarks
	Amount of oil m ℓ (US fl oz, Imp fl oz)	
Front evaporator	75 (2.5, 2.6)	—
Condenser	75 (2.5, 2.6)	—
Liquid tank	5 (0.2, 0.2)	Add if compressor is not replaced.
In case of refrigerant leak	30 (1.0, 1.1)	Large leak
	—	Small leak *1

*1: If refrigerant leak is small, no addition of oil is needed.

Oil Adjustment Procedure for Compressor Replacement

OIL

< ON-VEHICLE MAINTENANCE >

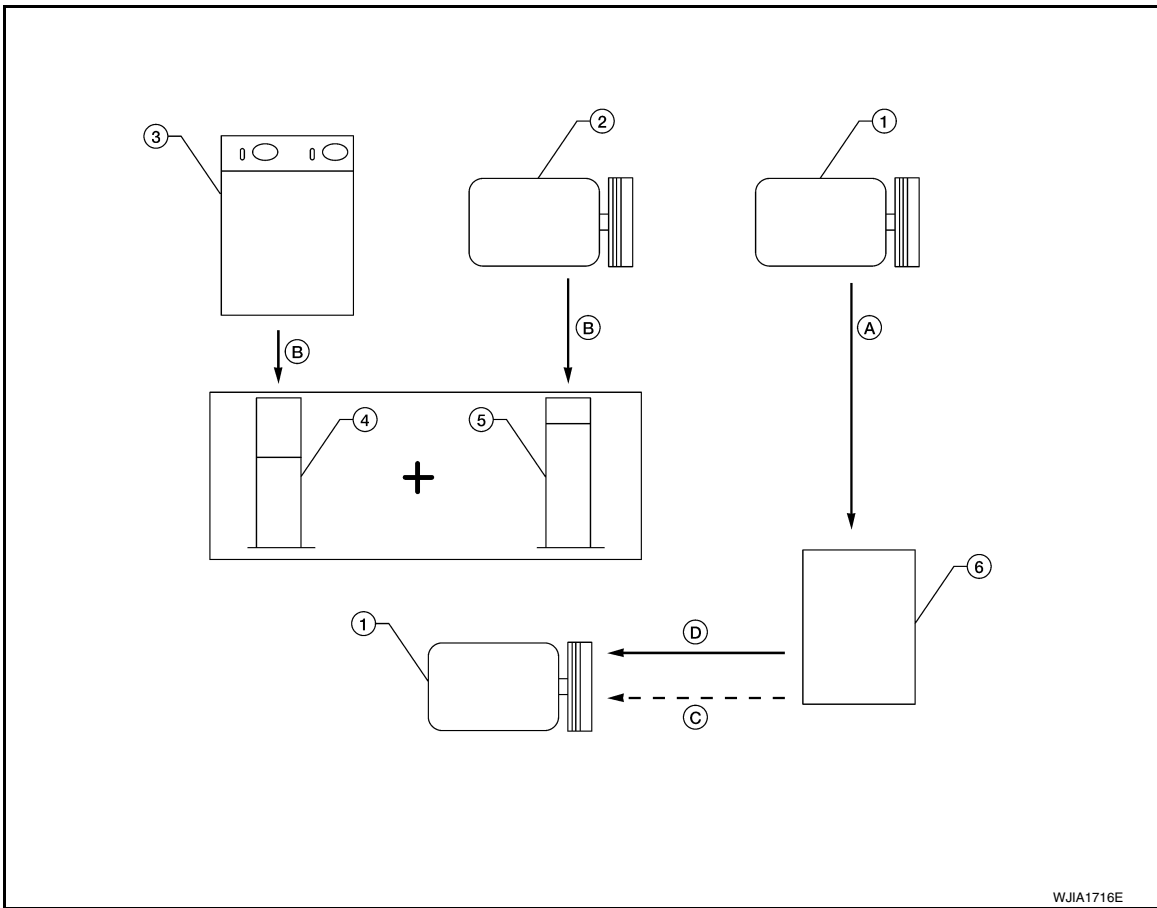

- | | | |
|-------------------------------------------------------------------------|-----------------------------------|------------------------------------------------------------------------------------------------|
| 1. New compressor | 2. Old compressor | 3. Recovery/recycling equipment |
| 4. Measuring cup X | 5. Measuring cup Y | 6. New oil |
| A. Drain oil from the new compressor into clean container | B. Record amount of oil recovered | C. Add an additional 5 m ℓ (0.2 US fl oz, 0.2 Imp fl oz) of new oil when replacing liquid tank |
| D. Install new oil equal to recorded amounts in measuring cups X plus Y | | |

- Before connecting recovery/recycling equipment to vehicle, check recovery/recycling equipment gauges. No refrigerant pressure should be displayed. If NG, recover refrigerant from equipment lines.
- Connect recovery/recycling equipment to vehicle. Confirm refrigerant purity in supply tank using recovery/recycling equipment and refrigerant identifier. If NG, refer to [HA-4, "Contaminated Refrigerant"](#).
- Confirm refrigerant purity in vehicle A/C system using recovery/recycling equipment and refrigerant identifier. If NG, refer to [HA-4, "Contaminated Refrigerant"](#).
- Discharge refrigerant into the refrigerant recovery/recycling equipment. Measure oil discharged into the recovery/recycling equipment.
- Drain the oil from the "old" (removed) compressor into a graduated container and recover the amount of oil drained.
- Drain the oil from the "new" compressor into a separate, clean container.
- Measure an amount of new oil installed equal to amount drained from "old" compressor. Add this oil to "new" compressor through the suction port opening.
- Measure an amount of new oil equal to the amount recovered during discharging. Add this oil to "new" compressor through the suction port opening.
- If the liquid tank also needs to be replaced, add an additional 5 m ℓ (0.2 US fl oz, 0.2 Imp fl oz) of oil at this time.

Do not add this 5 m ℓ (0.2 US fl oz, 0.2 Imp fl oz) of oil if only replacing the compressor.

FLUORESCENT LEAK DETECTOR

< ON-VEHICLE MAINTENANCE >

FLUORESCENT LEAK DETECTOR

Checking of Refrigerant Leaks

INFOID:000000005268010

PRELIMINARY CHECK

Perform a visual inspection of all refrigeration parts, fittings, hoses and components for signs of A/C oil leakage, damage, and corrosion. Any A/C oil leakage may indicate an area of refrigerant leakage. Allow extra inspection time in these areas when using either an electronic refrigerant leak detector (J-41995) or fluorescent dye leak detector (J-42220).

If any dye is observed using a fluorescent dye leak detector (J-42220), confirm the leak using a electronic refrigerant leak detector (J-41995). It is possible that the dye is from a prior leak that was repaired and not properly cleaned.

When searching for leaks, do not stop when one leak is found but continue to check for additional leaks at all system components and connections.

When searching for refrigerant leaks using an electronic refrigerant leak detector (J-41995), move the probe along the suspected leak area at 25 - 50 mm (1 - 2 in) per second and no further than 6 mm (1/4 in) from the component.

CAUTION:

Moving the electronic refrigerant leak detector probe slower and closer to the suspected leak area will improve the chances of finding a leak.

Checking System for Leaks Using the Fluorescent Dye Leak Detector

INFOID:000000005268011

1. Check the A/C system for leaks using the fluorescent dye leak detector and safety goggles (J-42220) in a low sunlight area (area without windows preferable). Illuminate all components, fittings and lines. The dye will appear as a bright green/yellow area at the point of leakage. Fluorescent dye observed at the evaporator drain opening indicates an evaporator core assembly leak (tubes, core or expansion valve).
2. If the suspected area is difficult to see, use an adjustable mirror or wipe the area with a clean shop rag or cloth, then inspect the shop rag or cloth with the fluorescent dye leak detector (J-42220) for dye residue.
3. After the leak is repaired, remove any residual dye using refrigerant dye cleaner (J-43872) to prevent future misdiagnosis.
4. Perform a system performance check and then verify the leak repair using a electronic refrigerant leak detector (J-41995).

NOTE:

- Other gases in the work area or substances on the A/C components, for example, anti-freeze, windshield washer fluid, solvents and oils, may falsely trigger the leak detector. Make sure the surfaces to be checked are clean.
- Clean with a dry cloth or blow off with shop air.
- Do not allow the sensor tip of the electronic refrigerant leak detector (J-41995) to contact with any substance. This can also cause false readings and may damage the detector.

Dye Injection

INFOID:000000005268012

NOTE:

This procedure is only necessary when recharging the system or when the compressor has seized and must be replaced.

1. Check the A/C system static (at rest) pressure. Pressure must be at least 345 kPa (3.52 kg/cm² , 50 psi).
2. Pour one bottle 7.4 cc (1/4 ounce) of the HFC-134a (R-134a) fluorescent leak detection dye (J-41447) into the HFC-134a (R-134a) dye injector (J-41459).

CAUTION:

If repairing the A/C system or replacing a component, pour the HFC-134a (R-134a) fluorescent leak detection dye (J-41447) directly into the open system connection and proceed with the service procedures.

3. Connect the refrigerant dye injector (J-41459) to the low-pressure service valve.
4. Start the engine and switch the A/C system ON.
5. When the A/C system is operating (compressor running), inject one bottle 7.4 cc (1/4 ounce) of HFC-134a (R-134a) fluorescent leak detection dye (J-41447) through the low-pressure service valve using HFC-134a (R-134a) dye injector (J-41459). Refer to the manufacturer's operating instructions.

FLUORESCENT LEAK DETECTOR

< ON-VEHICLE MAINTENANCE >

6. With the engine still running, disconnect the HFC-134a (R-134a) dye injector (J-41459) from the low-pressure service valve.
7. Operate the A/C system for a minimum of 20 minutes to mix the HFC-134a (R-134a) fluorescent leak detection dye (J-41447) with the A/C system oil. Depending on the leak size, operating conditions and location of the leak, it may take from minutes to days for the HFC-134a (R-134a) fluorescent leak detection dye to penetrate an A/C system leak and become visible.

A

B

C

D

E

F

G

H

HA

J

K

L

M

N

O

P

ELECTRICAL LEAK DETECTOR

< ON-VEHICLE MAINTENANCE >

ELECTRICAL LEAK DETECTOR

Checking of Refrigerant Leaks

INFOID:000000005268013

PRELIMINARY CHECK

Perform a visual inspection of all refrigeration parts, fittings, hoses and components for signs of A/C oil leakage, damage, and corrosion. Any A/C oil leakage may indicate an area of refrigerant leakage. Allow extra inspection time in these areas when using either an electronic refrigerant leak detector (J-41995) or fluorescent dye leak detector (J-42220).

If any dye is observed using a fluorescent dye leak detector (J-42220), confirm the leak using a electronic refrigerant leak detector (J-41995). It is possible that the dye is from a prior leak that was repaired and not properly cleaned.

When searching for leaks, do not stop when one leak is found but continue to check for additional leaks at all system components and connections.

When searching for refrigerant leaks using an electronic refrigerant leak detector (J-41995), move the probe along the suspected leak area at 25 - 50 mm (1 - 2 in) per second and no further than 6 mm (1/4 in) from the component.

CAUTION:

Moving the electronic refrigerant leak detector probe slower and closer to the suspected leak area will improve the chances of finding a leak.

Electronic Refrigerant Leak Detector

INFOID:000000005268014

PRECAUTIONS FOR HANDLING LEAK DETECTOR

NOTE:

When performing a refrigerant leak check, use a electronic refrigerant leak detector (J-41995) or equivalent. Ensure that the electronic refrigerant leak detector (J-41995) is calibrated and set properly according to the manufacturer's operating instructions.

The electronic refrigerant leak detector (J-41995) is a delicate device. To use the electronic refrigerant leak detector (J-41995) properly, read the manufacturer's operating instructions and perform any specified maintenance.

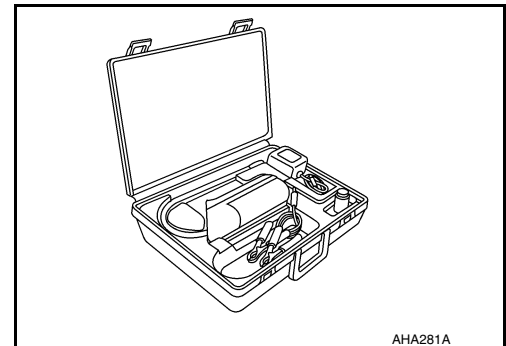

1. Position the probe approximately 5 mm (3/16 in) away from the point to be checked as shown.

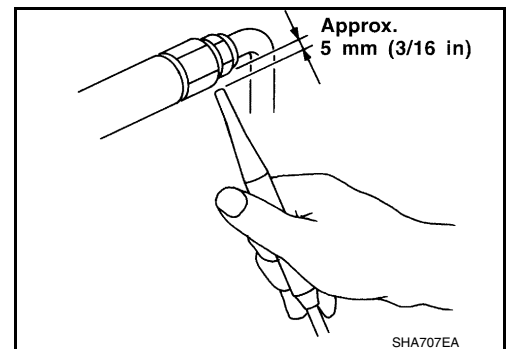

ELECTRICAL LEAK DETECTOR

< ON-VEHICLE MAINTENANCE >

- When checking for leaks, circle each fitting completely with the probe as shown.

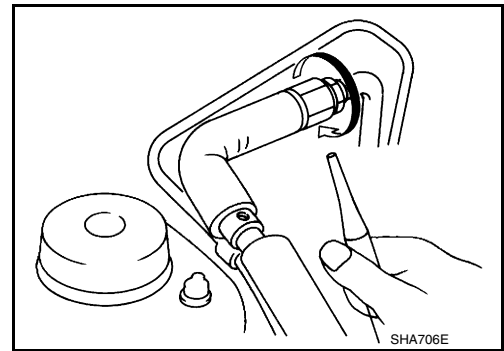

- Move the probe along each component at a speed of approximately 25 - 50 mm (1 - 2 in)/second as shown.

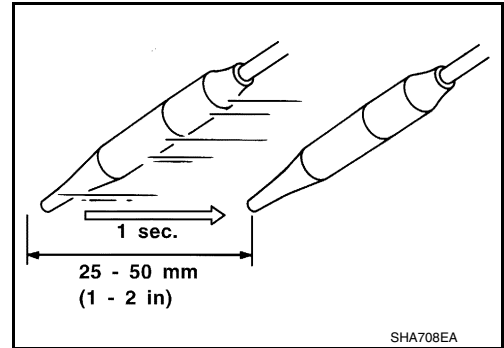

CHECKING PROCEDURE

NOTE:

To prevent inaccurate or false readings, make sure there is no refrigerant vapor, shop chemicals, or cigarette smoke in the vicinity of the vehicle. Perform the leak test in a calm area (low air/wind movement) so that the leaking refrigerant is not dispersed.

- Turn the engine OFF.
- Connect the manifold gauge set (J-39183-C) to the A/C service ports. Refer to [HA-27. "HFC-134a \(R-134a\) Service Procedure"](#).
- Check if the A/C refrigerant pressure is at least 345 kPa (3.52 kg/cm², 50 psi) above a temperature of 16°C (61°F). If less than specification, recover/evacuate and recharge the system with the specified amount of refrigerant. Refer to [HA-27. "HFC-134a \(R-134a\) Service Procedure"](#).

NOTE:

At temperatures below 16°C (61°F), leaks may not be detected since the system may not reach 345 kPa (3.52 kg/cm², 50 psi) pressure.

- Perform the leak test from the high-pressure side (front A/C compressor discharge "a" to evaporator inlet "f") to the low-pressure side (front A/C evaporator drain hose "g" to shaft seal "k"). Refer to [HA-25. "Component"](#). Clean the component to be checked and carefully move the electronic refrigerant leak detector probe completely around the following connections and components.

- Check the compressor shaft seal
- Check the high and low-pressure pipe and hose fittings, relief valve, and compressor shaft seal
- Check the liquid tank
- Check the refrigerant pressure sensor
- Check all around the service valves. Check that the service valve caps are screwed tightly on the service valves (to prevent leaks).

NOTE:

After removing manifold gauge set (J-39183-C) from the service valves, wipe any residue from the service valves to prevent any false readings by the electronic refrigerant leak detector (J-41995).

- Evaporator

With engine OFF, turn blower fan on "High" for at least 15 seconds to dissipate any refrigerant trace in the heater and cooling unit assembly. Wait a minimum of 10 minutes accumulation time (refer to the manufacturer's recommended procedure for actual wait time) before inserting the electronic refrigerant leak detector probe into the heater and cooling unit assembly drain hose.

NOTE:

Keep the probe inserted for at least 10 seconds. Use caution not to contaminate the probe tip with water or dirt that may be in the drain hose.

A
B
C
D
E
F
G
H
HA
J
K
L
M
N
O
P

ELECTRICAL LEAK DETECTOR

< ON-VEHICLE MAINTENANCE >

5. If a leak is detected, verify at least once by blowing compressed air into the area of the suspected leak, then repeat the leak check.
6. Do not stop when one leak is found. Continue to check for additional leaks at all system components and connections.
7. If no leaks are found, perform steps 8 - 11.
8. Start the engine.
9. Set the heater A/C controls as follows:
 - a. A/C switch to ON
 - b. Air flow to VENT mode
 - c. Intake position to RECIRCULATION mode
 - d. Temperature to MAX cold
 - e. Blower fan speed to HIGH
10. Run the engine at 1,500 rpm for at least 2 minutes.
11. Turn the engine OFF and perform the leak check again following steps 4 through 6 above.

Refrigerant leaks should be checked immediately after turning the engine OFF. Begin with the leak detector at the compressor. The pressure on the high pressure side will gradually drop after the refrigerant circulation stops and pressure on the low pressure side will gradually rise, as shown in the graph. Some leaks are more easily detected when the pressure is high.

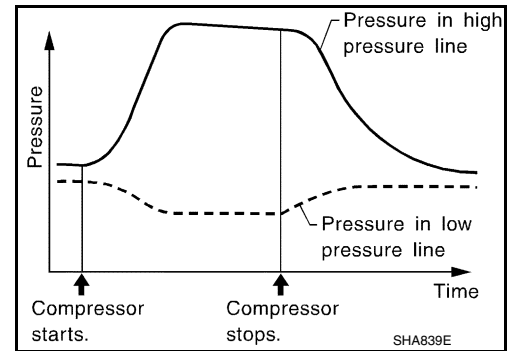

12. Before connecting the recovery/recycling equipment to the vehicle, check the recovery/recycling equipment gauges. No refrigerant pressure should be displayed. If pressure is displayed, recover the refrigerant from the equipment lines and then check the refrigerant purity.
13. Confirm refrigerant purity in supply tank using recovery/recycling equipment and refrigerant identifier equipment (J-41810-NI).
14. Confirm the refrigerant purity in the vehicle's A/C system using recovery/recycling equipment and refrigerant identifier equipment (J-41810-NI).
15. Discharge the A/C system using recovery/recycling equipment. Repair the leaking fitting or component as necessary.
16. Evacuate and recharge the A/C system and perform the leak test to confirm that there are no refrigerant leaks.
17. Conduct the Operational Check to ensure system works properly. Refer to [HAC-6. "Operational Check"](#).

REFRIGERATION SYSTEM

< ON-VEHICLE REPAIR >

ON-VEHICLE REPAIR

REFRIGERATION SYSTEM

Component

INFOID:000000005268015

CAUTION:

The new and former refrigerant connections use different O-ring configurations. Do not confuse O-rings since they are not interchangeable. If a wrong O-ring is installed, refrigerant will leak at or around the connection.

FRONT REFRIGERATION SYSTEM

A

B

C

D

E

F

G

H

HA

J

K

L

M

N

O

P

REFRIGERATION SYSTEM

< ON-VEHICLE REPAIR >

Front A/C Compressor and Condenser

SEC. 270 • 271 • 274 • 276 • 278

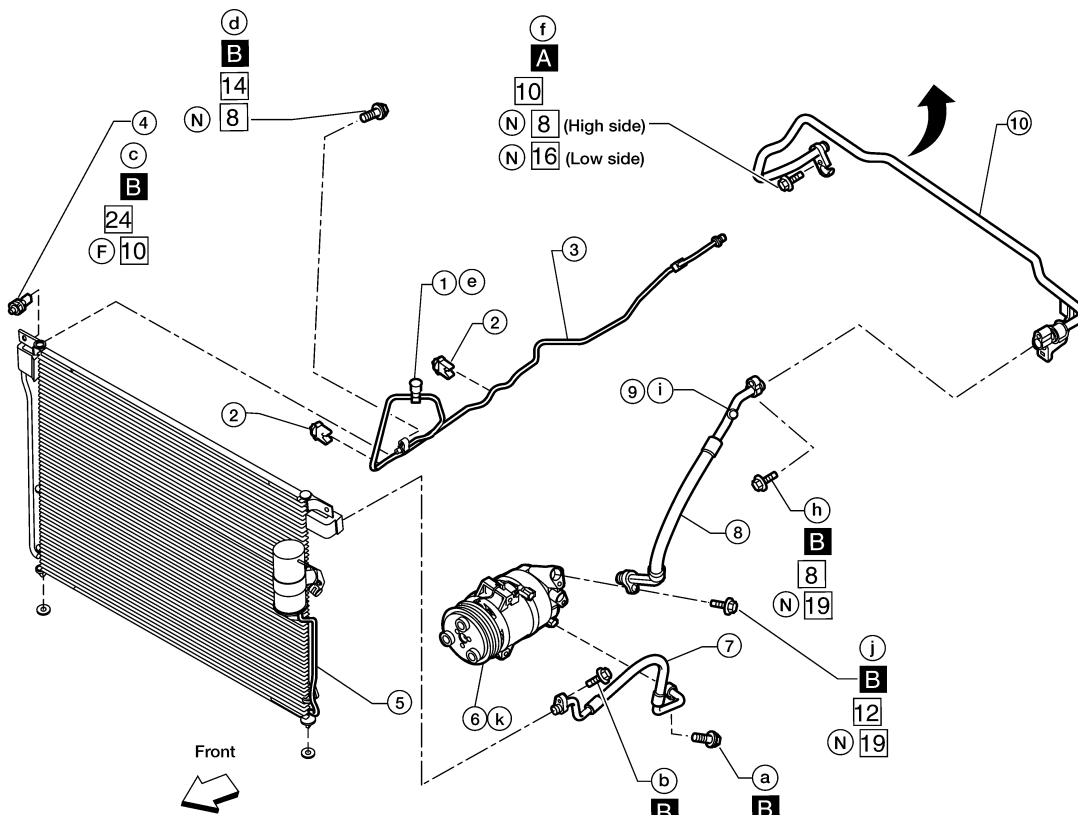
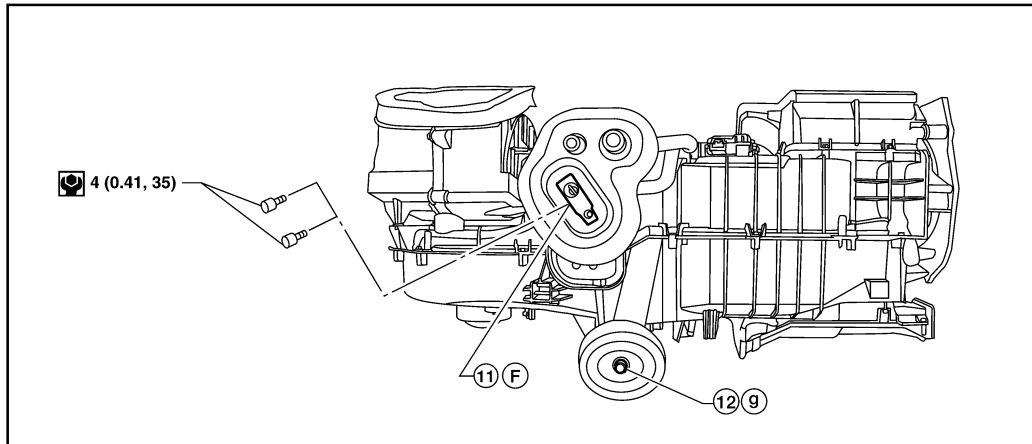

- : Refrigerant leak checking order (a-k)
- : Tightening torque
- : Wrench size
- : O-ring size
- ⊙ : N-m (kg-m, in-lb)
- A** : 3.4 (0.35, 30)
- B** : 9.3 (0.95, 82)
- (F) : Former type refrigerant connection
- (N) : New type refrigerant connection

WJIA1481E

- | | | |
|------------------------------------------|-----------------------------------------|---------------------------------|
| 1. High-pressure service valve | 2. Clip | 3. Front high-pressure A/C pipe |
| 4. Refrigerant pressure sensor | 5. Condenser | 6. Compressor shaft seal |
| 7. Front high-pressure flexible A/C hose | 8. Front low-pressure flexible A/C hose | 9. Low-pressure service valve |
| 10. Front low-pressure A/C pipe | 11. Front expansion valve | 12. Front A/C drain hose |

REFRIGERATION SYSTEM

< ON-VEHICLE REPAIR >

HFC-134a (R-134a) Service Procedure

INFOID:000000005268016

SETTING OF SERVICE TOOLS AND EQUIPMENT

Discharging Refrigerant

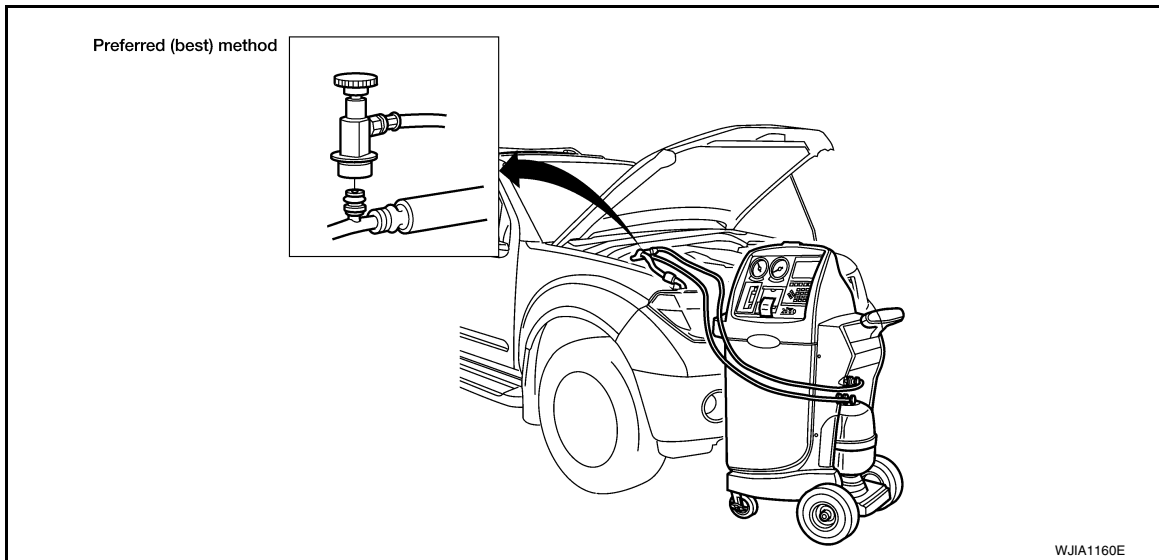

1. Shut-off valve
2. A/C service valve
3. Recovery/recycling equipment

WARNING:

Avoid breathing A/C refrigerant and oil vapor or mist. Exposure may irritate eyes, nose and throat. Remove HFC-134a (R-134a) refrigerant from the A/C system using certified service equipment meeting requirements of SAE J2210 HFC-134a (R-134a) recycling equipment or SAE J2201 HFC-134a (R-134a) recovery equipment. If an accidental system discharge occurs, ventilate the work area before resuming service. Additional health and safety information may be obtained from the refrigerant and oil manufacturers.

Evacuating System and Charging Refrigerant

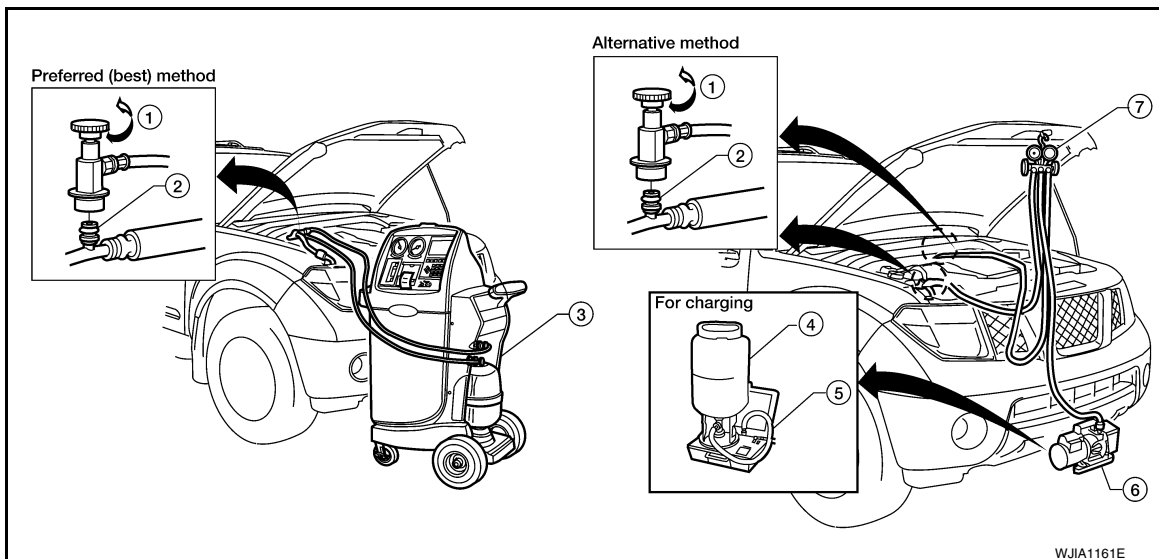

1. Shut-off valve
2. A/C service valve
3. Recovery/recycling equipment
4. Refrigerant container (HFC-134a)
5. Refrigerant weight scale (J-39699)
6. Vacuum pump (J-39649)
7. Manifold gauge set with hoses and couplers (J-39183-C)

COMPRESSOR

< ON-VEHICLE REPAIR >

COMPRESSOR

Removal and Installation for Compressor

INFOID:000000005268017

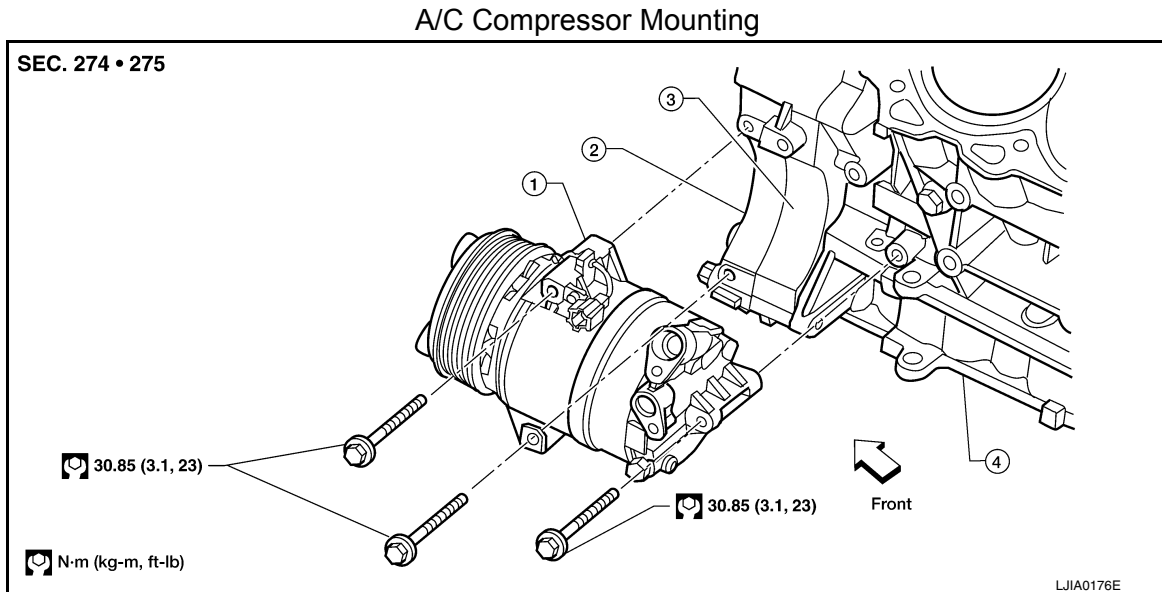

1. Compressor
2. Front timing chain case
3. Rear timing chain case
4. Cylinder block

REMOVAL

1. Discharge the A/C refrigerant. Refer to [HA-27, "HFC-134a \(R-134a\) Service Procedure"](#).
2. Remove the front left wheel and tire assembly. Refer to [WT-46, "Rotation"](#).
3. Remove the front left mud guard. Refer to [EXT-21, "Removal and Installation"](#).
4. Remove the LH front fender protector. Refer to [EXT-19, "Removal and Installation"](#).
5. Remove the engine cover. Refer to [EM-24, "Removal and Installation"](#).
6. Remove the engine air cleaner and air ducts. Refer to [EM-25, "Removal and Installation"](#).
7. Remove the drive belt. Refer to [EM-25, "Removal and Installation"](#).
8. Disconnect the compressor harness connector.
9. Disconnect both the front high-pressure flexible A/C hose and front low-pressure flexible A/C hose from the compressor.

CAUTION:

Cap or wrap the joint of the pipe with suitable material such as vinyl tape to avoid the entry of air.

10. Remove the A/C compressor bolts using power tools.

INSTALLATION

Installation is in the reverse order of removal.

CAUTION:

- Replace the O-ring of the front low-pressure flexible A/C hose and front high-pressure flexible A/C hose with a new one, apply compressor oil to the O-rings before installation.
- After recharging the A/C system with refrigerant, check for leaks. Refer to [HA-20, "Checking of Refrigerant Leaks"](#).

COMPRESSOR

< ON-VEHICLE REPAIR >

Removal and Installation for Compressor Clutch

INFOID:000000005268018

Magnet Clutch Assembly

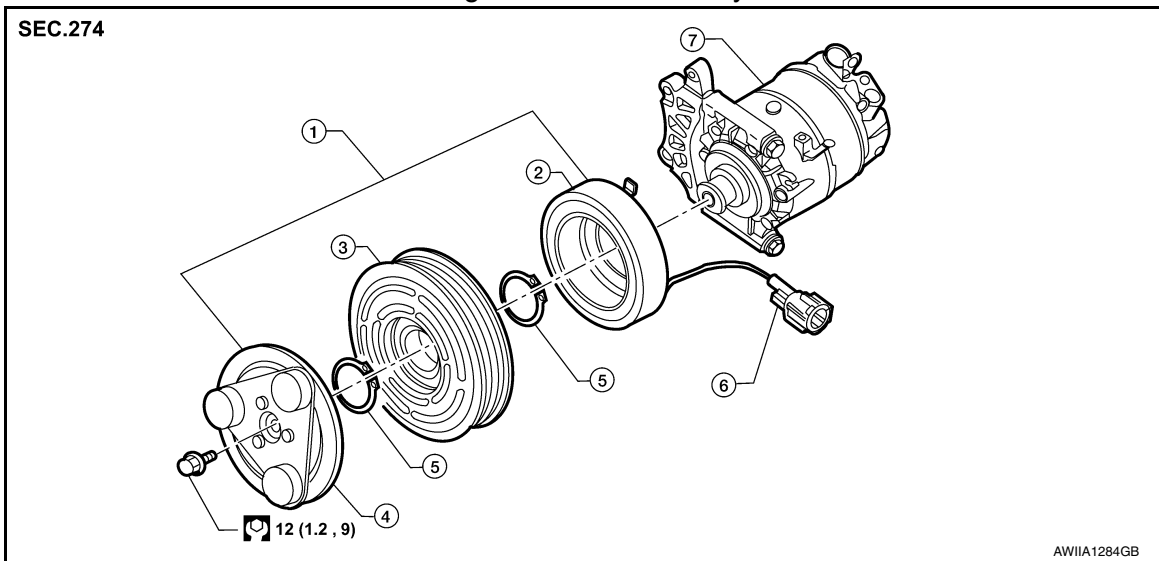

- | | | |
|---------------------------|----------------|---------------------------------|
| 1. Magnet clutch assembly | 2. Magnet coil | 3. Pulley |
| 4. Clutch disc | 5. Snap ring | 6. Thermal protector (built in) |
| 7. Compressor | | |

NOTE:

Illustrations for removal and installation are shown with the compressor out of the vehicle for clarity.

REMOVAL

1. Remove the engine cooling fan. Refer to [CO-18, "Removal and Installation \(Crankshaft driven type\)"](#).
2. Remove the center bolt while holding the clutch disc stationary using Tool as shown.

Tool number : J-44614

3. Remove the clutch disc and shim(s).

CAUTION:

Retain shims for installation.

4. Remove the snap ring using a suitable tool.

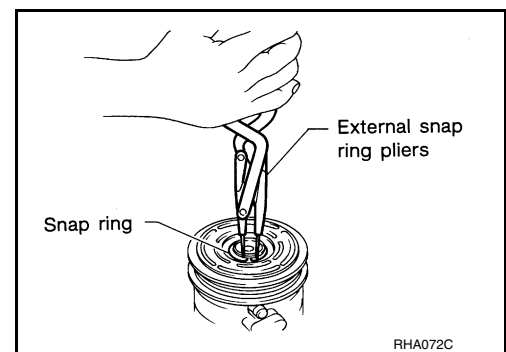
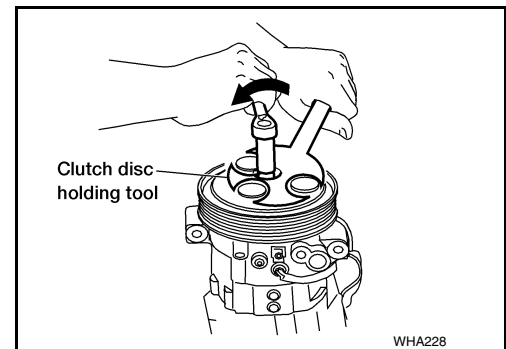

COMPRESSOR

< ON-VEHICLE REPAIR >

5. Remove the pulley using a suitable tool (A).

CAUTION:

To prevent deformation of the pulley groove, the puller claws should be hooked under the pulley groove and not into the pulley groove.

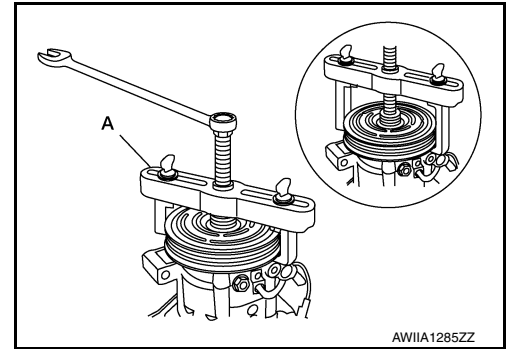

6. Remove the magnet coil snap ring (A) using a suitable tool and remove the magnet coil (1).

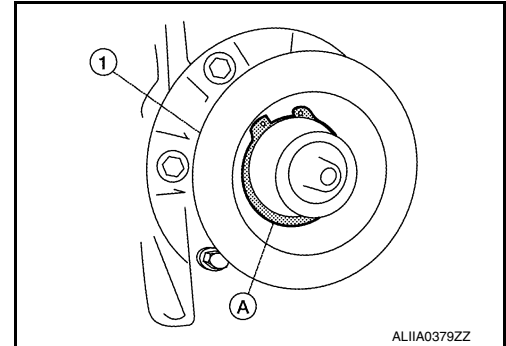

INSPECTION

Clutch Disc

If the contact surface shows signs of damage due to excessive heat, replace clutch disc and pulley.

Pulley

Check the appearance of the pulley assembly. If contact surface of pulley shows signs of excessive grooving, replace clutch disc and pulley. The contact surfaces of the pulley assembly should be cleaned with a suitable solvent before reinstallation.

Coil

Check magnet coil for loose connections or any cracked insulation. Replace as necessary.

INSTALLATION

1. Install the magnet coil and snap ring using a suitable tool.

CAUTION:

Be sure to align the magnet coil pin with the hole in the compressor front head.

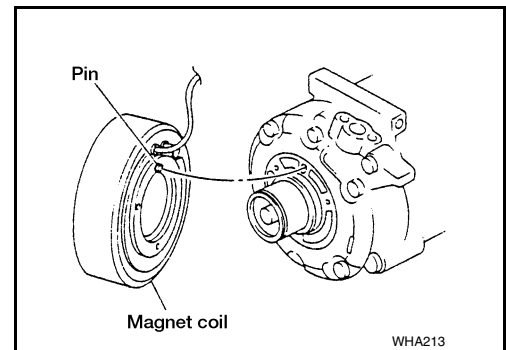

2. Install the pulley assembly using Tool and a wrench, then install the snap ring using a suitable tool.

Tool number : — (J-38873-A)

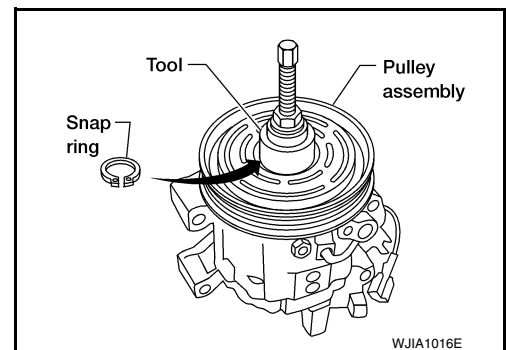

COMPRESSOR

< ON-VEHICLE REPAIR >

3. Install the clutch disc on the compressor shaft, together with the original shim(s) using a suitable tool. Press the clutch disc in by hand.

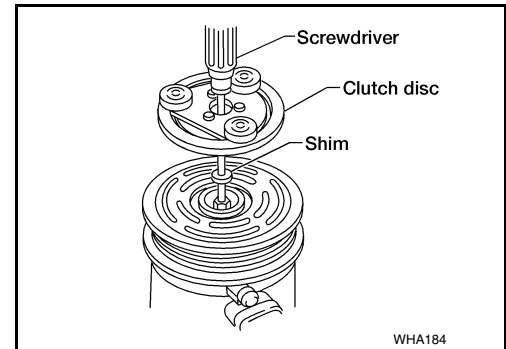

4. Install the clutch pulley bolt while using Tool to prevent the clutch disc from turning and tighten the bolt to specification.

Tool number : J-44614

CAUTION:

After tightening the clutch pulley bolt, check that the clutch pulley rotates smoothly.

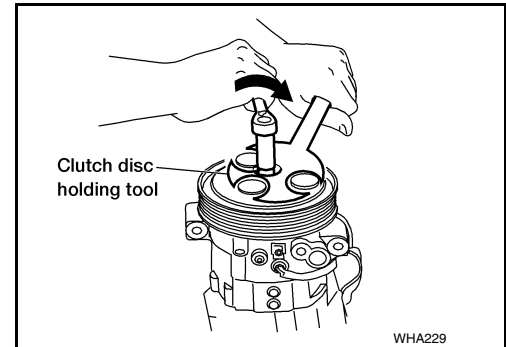

5. Check the pulley clearance all the way around the clutch disc as shown.

**Clutch disc-to-pulley clearance : 0.3 - 0.6 mm
(0.012 - 0.024 in)**

6. If the specified clearance is not obtained, replace the adjusting spacer to readjust.

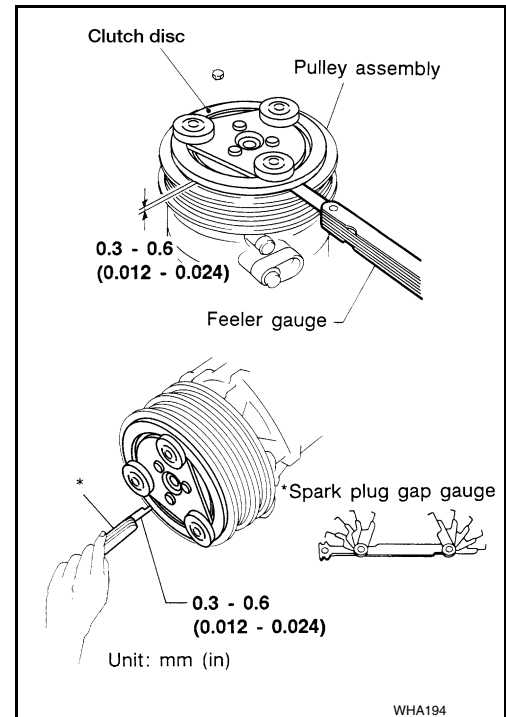

7. Install the engine cooling fan. Refer to [CO-18. "Removal and Installation \(Crankshaft driven type\)"](#).

BREAK-IN OPERATION

When replacing compressor clutch assembly, always conduct the break-in operation. This is done by engaging and disengaging the clutch about 30 times. Break-in operation raises the level of transmitted torque.

HIGH-PRESSURE FLEXIBLE HOSE

< ON-VEHICLE REPAIR >

HIGH-PRESSURE FLEXIBLE HOSE

Removal and Installation for Front High-pressure Flexible A/C Hose

INFOID:000000005268019

REMOVAL

1. Remove the front left wheel and tire assembly. Refer to [WT-46. "Rotation"](#).
2. Remove the front left mud guard.
3. Remove the front left splash shield.
4. Discharge the refrigerant. Refer to [HA-27. "HFC-134a \(R-134a\) Service Procedure"](#).
5. Remove the front high-pressure flexible A/C hose. Refer to [HA-25. "Component"](#).

CAUTION:

Cap or wrap the joint of the pipe with suitable material such as vinyl tape to avoid the entry of air.

INSTALLATION

Installation is in the reverse order of removal.

Refer to [HA-25. "Component"](#).

CAUTION:

- **Replace the O-ring of the front high-pressure flexible A/C hose with a new one, then apply compressor oil to it for installation.**
- **After charging refrigerant, check for leaks.**

HIGH-PRESSURE PIPE

< ON-VEHICLE REPAIR >

HIGH-PRESSURE PIPE

Removal and Installation for Front High-pressure A/C Pipe

INFOID:000000005268020

REMOVAL

1. Remove the front right wheel and tire assembly. Refer to [WT-46, "Rotation"](#).
2. Remove the front right mud guard.
3. Remove the front right splash shield.
4. Discharge the refrigerant. Refer to [HA-27, "HFC-134a \(R-134a\) Service Procedure"](#).
5. Remove the front low pressure A/C pipe. Refer to [HA-35, "Removal and Installation for Front Low-Pressure A/C Pipe"](#).
6. Remove the front high-pressure A/C pipe. Refer to [HA-25, "Component"](#).

CAUTION:

Cap or wrap the joint of the pipe with suitable material such as vinyl tape to avoid the entry of air.

INSTALLATION

Installation is in the reverse order of removal.

Refer to [HA-25, "Component"](#).

CAUTION:

- Replace the O-ring of the front high-pressure A/C pipe with a new one, then apply compressor oil to it for installation.
- After charging refrigerant, check for leaks.

A
B
C
D
E
F
G
H
J
K
L
M
N
O
P

HA

LOW-PRESSURE FLEXIBLE HOSE

< ON-VEHICLE REPAIR >

LOW-PRESSURE FLEXIBLE HOSE

Removal and Installation for Front Low-Pressure Flexible A/C Hose

INFOID:000000005268021

REMOVAL

1. Remove the front right wheel and tire assembly. Refer to [WT-46. "Rotation"](#).
2. Remove the front right mud guard.
3. Remove the front right splash shield.
4. Discharge the refrigerant. Refer to [HA-27. "HFC-134a \(R-134a\) Service Procedure"](#).

CAUTION:

Cap or wrap the joint of the pipe with suitable material such as vinyl tape to avoid the entry of air.

5. Remove the front low-pressure flexible A/C hose. Refer to [HA-25. "Component"](#).

INSTALLATION

Installation is in the reverse order of removal.

Refer to [HA-25. "Component"](#).

CAUTION:

- **Replace the O-ring of the front low-pressure flexible A/C hose with a new one, then apply compressor oil to it for installation.**
- **After charging refrigerant, check for leaks.**

LOW-PRESSURE PIPE

< ON-VEHICLE REPAIR >

LOW-PRESSURE PIPE

Removal and Installation for Front Low-Pressure A/C Pipe

INFOID:000000005268022

REMOVAL

1. Discharge the refrigerant. Refer to [HA-27. "HFC-134a \(R-134a\) Service Procedure"](#).
2. Disconnect the heater pump connector.
3. Remove the heater pump from the bracket and reposition out of the way. Do not disconnect the heater hoses from the heater pump.
4. Remove the front low-pressure A/C pipe. Refer to [HA-25. "Component"](#).

CAUTION:

Cap or wrap the joint of the pipe with suitable material such as vinyl tape to avoid the entry of air.

INSTALLATION

Installation is in the reverse order of removal.

Refer to [HA-25. "Component"](#).

CAUTION:

- **Replace the O-ring of the front low-pressure A/C pipe with a new one, then apply compressor oil to it for installation.**
- **After charging refrigerant, check for leaks.**

A

B

C

D

E

F

G

H

HA

J

K

L

M

N

O

P

CONDENSER

< ON-VEHICLE REPAIR >

CONDENSER

Removal and Installation for Condenser

INFOID:000000005268023

REMOVAL

1. Discharge the refrigerant. Refer to [HA-27. "HFC-134a \(R-134a\) Service Procedure"](#).
2. Remove the radiator. Refer to [CO-15. "Removal and Installation"](#).
CAUTION:
Be careful not to damage the core surface of the condenser and the radiator.
3. Disconnect the front high-pressure flexible A/C hose and the front high-pressure A/C pipe from the condenser.
CAUTION:
Cap or wrap the joint of the pipes with suitable material such as vinyl tape to avoid the entry of air.
4. Disconnect the refrigerant pressure sensor harness connector.
5. Remove the refrigerant pressure sensor from the condenser.
6. Lift the condenser out of the mounting grommets and remove the condenser.

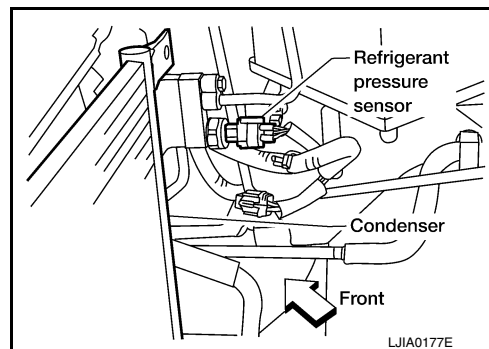

INSTALLATION

Installation is in the reverse order of removal.

Refer to [HA-25. "Component"](#).

CAUTION:

- Replace the O-rings of the front high-pressure A/C pipe, refrigerant pressure sensor, and front high-pressure flexible A/C hose with new ones, then apply compressor oil to them for installation.
- After charging refrigerant, check for leaks.
- Replace the mounting grommets as necessary.

REFRIGERANT PRESSURE SENSOR

< ON-VEHICLE REPAIR >

REFRIGERANT PRESSURE SENSOR

Removal and Installation for Refrigerant Pressure Sensor

INFOID:000000005268024

REMOVAL

1. Discharge the refrigerant. Refer to [HA-27. "HFC-134a \(R-134a\) Service Procedure"](#).
2. Disconnect the refrigerant pressure sensor harness connector and remove the refrigerant pressure sensor from the condenser.

CAUTION:

Be careful not to damage the condenser fins.

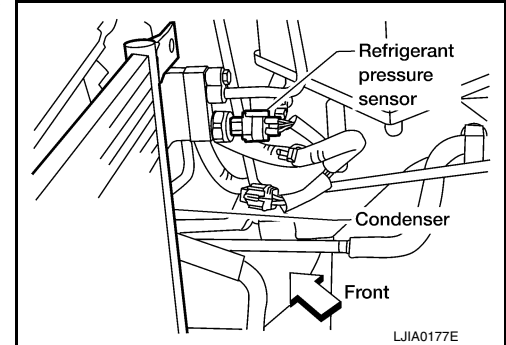

INSTALLATION

Installation is in the reverse order of removal.

Refer to [HA-25. "Component"](#).

CAUTION:

- Be careful not to damage the condenser fins.
- Replace the O-ring of the refrigerant pressure sensor with a new one, then apply compressor oil to it for installation.
- After charging refrigerant, check for leaks.

A
B
C
D
E
F
G
H
J
K
L
M
N
O
P

HA

EXPANSION VALVE

< ON-VEHICLE REPAIR >

EXPANSION VALVE

Removal and Installation for Front Expansion Valve

INFOID:000000005268025

REMOVAL

1. Discharge the refrigerant. Refer to [HA-27, "HFC-134a \(R-134a\) Service Procedure"](#).
2. Remove the front heater and cooling unit assembly. Refer to [VTL-12, "Removal and Installation"](#).
3. Remove the front heater core and evaporator pipes grommet.
4. Remove the front expansion valve.

INSTALLATION

Installation is in the reverse order of removal.

Expansion valve bolts : Refer to [HA-25, "Component"](#).

A/C refrigerant pipe to expansion valve bolt : Refer to [HA-25, "Component"](#).

CAUTION:

- Replace the O-rings on the front expansion valve and the A/C refrigerant pipes with new ones, then apply compressor oil to them for installation.
- After charging refrigerant, check for leaks.

SERVICE DATA AND SPECIFICATIONS (SDS)

< SERVICE DATA AND SPECIFICATIONS (SDS)

SERVICE DATA AND SPECIFICATIONS (SDS)

SERVICE DATA AND SPECIFICATIONS (SDS)

Service Data and Specification (SDS)

INFOID:000000005268026

COMPRESSOR

Make	CALSONIC KANSEI CO. LTD.
Model	CR - 14
Type	Vane rotary (5 vanes)
Displacement	144 cm ³ (8.79 in ³) / revolution
Relief valve set pressure	3800 ± 300 kPa (38.76 ± 3.06 kg/cm ² , 551.0 ± 43.5 psi)
Direction of rotation	Clockwise (viewed from drive end)
Drive belt	Poly V ribbed

OIL

Name	NISSAN A/C System Oil Type R or equivalent
Capacity	180 mℓ (6.1 US fl oz, 6.3 Imp fl oz)

REFRIGERANT

Type	HFC 134a (R-134a)
Capacity	0.70 ± 0.05 kg (1.54 ± 0.11 lb)