

SECTION **MIR**
MIRRORS

A
B
C
D
E
F
G
H
I
J
K
M
N
O
P

CONTENTS

COMPONENT DIAGNOSIS	2	SERVICE INFORMATION	11
DOOR MIRROR	2	PREPARATION	11
Wiring Diagram — Door Mirror (With Heated Mirrors) —	2	Special Service Tool	11
Wiring Diagram — Door Mirror (Without Heated Mirrors) —	5	Commercial Service Tool	11
INSIDE MIRROR	8	INSIDE MIRROR	12
Wiring Diagram	8	Removal and Installation	12
PRECAUTION	10	DOOR MIRROR	13
PRECAUTIONS	10	Door Mirror Assembly	13
Precaution for Supplemental Restraint System (SRS) "AIR BAG" and "SEAT BELT PRE-TENSIONER"	10	Door Mirror Glass	13
		DISASSEMBLY AND ASSEMBLY	14
		DOOR MIRROR	14
		Mirror Actuator	14

MIR

DOOR MIRROR

< COMPONENT DIAGNOSIS >

COMPONENT DIAGNOSIS

DOOR MIRROR

Wiring Diagram — Door Mirror (With Heated Mirrors) —

INFOID:000000005268687

DOOR MIRROR - WITH HEATED MIRRORS

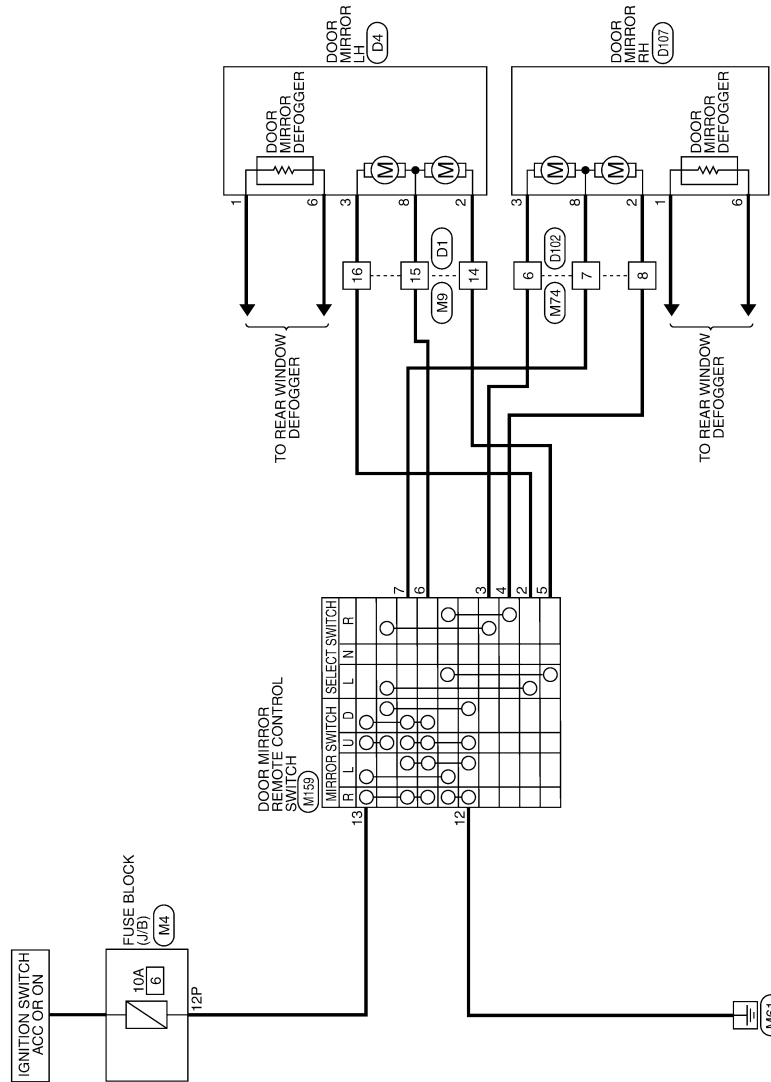

ABLWA0647GB

DOOR MIRROR

< COMPONENT DIAGNOSIS >

DOOR MIRROR CONNECTORS - WITH HEATED MIRRORS

Connector No.	M4
Connector Name	FUSE BLOCK (J/B)
Connector Color	WHITE



Terminal No.	Color of Wire	Signal Name
12P	G/Y	-

Connector No.	M9
Connector Name	WIRE TO WIRE
Connector Color	WHITE

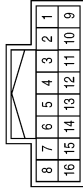

Terminal No.	Color of Wire	Signal Name
14	Y	-
15	V	-
16	L	-

Connector No.	M74
Connector Name	WIRE TO WIRE
Connector Color	WHITE

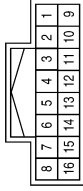

Terminal No.	Color of Wire	Signal Name
6	R	-
7	P	-
8	LG	-

Connector No.	M159
Connector Name	DOOR MIRROR REMOTE CONTROL SWITCH
Connector Color	WHITE

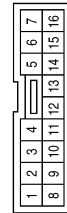

Terminal No.	Color of Wire	Signal Name
2	L	-
3	R	-

Terminal No.	Color of Wire	Signal Name
4	LG	-
5	Y	-
6	V	-
7	P	-
12	B	-
13	G/Y	-

Connector No.	D1
Connector Name	WIRE TO WIRE
Connector Color	WHITE

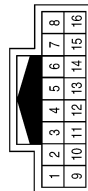

Terminal No.	Color of Wire	Signal Name
14	Y/R	-
15	V/W	-
16	L/R	-

A
B
C
D
E
F
G
H
I
J
K
M
N
O
P

MIR

DOOR MIRROR

< COMPONENT DIAGNOSIS >

Connector No.	D107
Connector Name	DOOR MIRROR RH (WITH HEATED MIRRORS)
Connector Color	BLACK

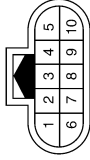

Terminal No.	Color of Wire	Signal Name
1	L/B	-
2	Y/B	-
3	L/B	-
6	B	-
8	V/W	-

Connector No.	D102
Connector Name	WIRE TO WIRE
Connector Color	WHITE

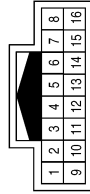

Terminal No.	Color of Wire	Signal Name
6	L/B	-
7	V/W	-
8	Y/B	-

Connector No.	D4
Connector Name	DOOR MIRROR LH (WITH HEATED MIRRORS)
Connector Color	BLACK

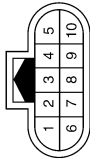

Terminal No.	Color of Wire	Signal Name
1	L/B	-
2	Y/R	-
3	L/R	-
6	B	-
8	V/W	-

ABLIA0623GB

DOOR MIRROR

< COMPONENT DIAGNOSIS >

Wiring Diagram — Door Mirror (Without Heated Mirrors) —

INFOID:000000005268688

DOOR MIRROR - WITHOUT HEATED MIRRORS

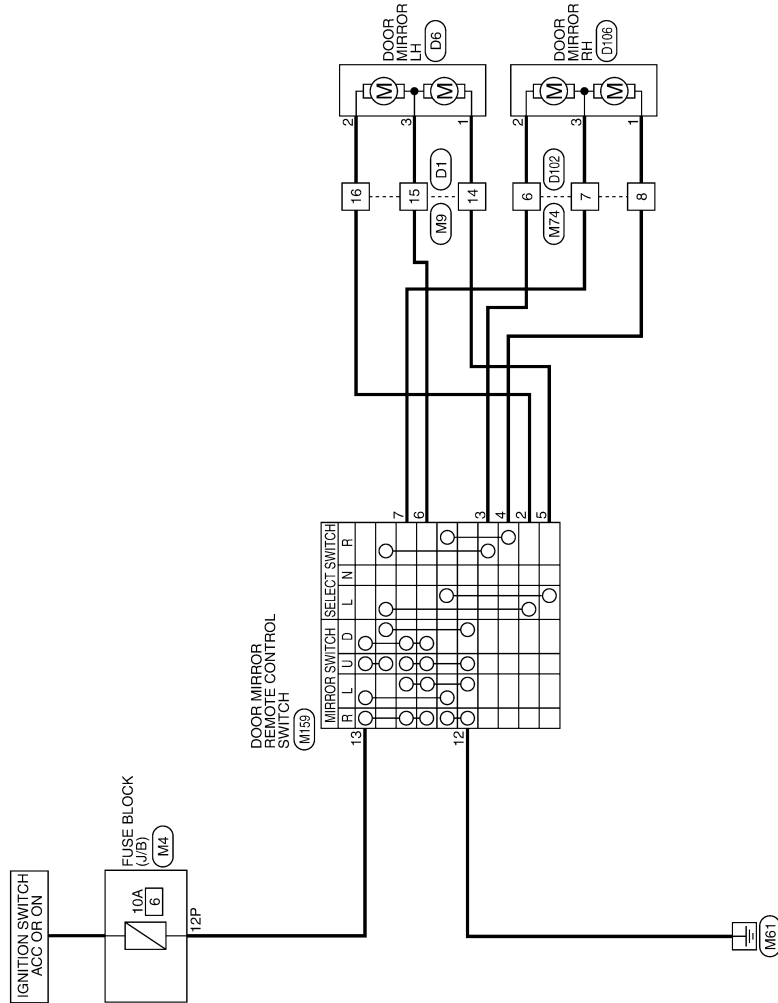

A
B
C
D
E
F
G
H
I
J
K
L
M
N
O
P

MIR

ABLWA0648GB

DOOR MIRROR

< COMPONENT DIAGNOSIS >

DOOR MIRROR CONNECTORS - WITHOUT HEATED MIRRORS

Connector No.	M4
Connector Name	FUSE BLOCK (J/B)
Connector Color	WHITE

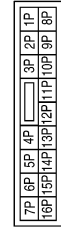

Terminal No.	Color of Wire	Signal Name
12P	G/Y	-

Connector No.	M9
Connector Name	WIRE TO WIRE
Connector Color	WHITE

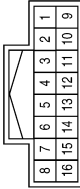

Terminal No.	Color of Wire	Signal Name
14	Y	-
15	V	-
16	L	-

Connector No.	M74
Connector Name	WIRE TO WIRE
Connector Color	WHITE

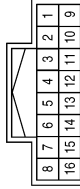

Terminal No.	Color of Wire	Signal Name
6	R	-
7	P	-
8	LG	-

Connector No.	M159
Connector Name	DOOR MIRROR REMOTE CONTROL SWITCH
Connector Color	WHITE

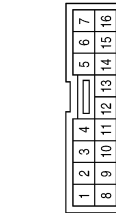

Terminal No.	Color of Wire	Signal Name
2	L	-
3	R	-

Terminal No.	Color of Wire	Signal Name
4	LG	-
5	Y	-
6	V	-
7	P	-
12	B	-
13	G/Y	-

Connector No.	D1
Connector Name	WIRE TO WIRE
Connector Color	WHITE



Terminal No.	Color of Wire	Signal Name
14	Y/R	-
15	V/W	-
16	L/R	-

AWLIA0432GB

DOOR MIRROR

< COMPONENT DIAGNOSIS >

Connector No.	D106
Connector Name	DOOR MIRROR RH (WITH-OUT HEATED MIRRORS)
Connector Color	BLACK



Terminal No.	Color of Wire	Signal Name
1	Y/B	-
2	L/B	-
3	V/W	-

Connector No.	D102
Connector Name	WIRE TO WIRE
Connector Color	WHITE

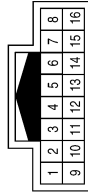

Terminal No.	Color of Wire	Signal Name
6	L/B	-
7	V/W	-
8	Y/B	-

Connector No.	D6
Connector Name	DOOR MIRROR LH (WITH-OUT HEATED MIRRORS)
Connector Color	BLACK



Terminal No.	Color of Wire	Signal Name
1	Y/R	-
2	L/R	-
3	V/W	-

A
B
C
D
E
F
G
H
I
J
K
M
N
O
P

MIR

ABLIA0624GB

INSIDE MIRROR

< COMPONENT DIAGNOSIS >

INSIDE MIRROR

Wiring Diagram

INFOID:000000005268689

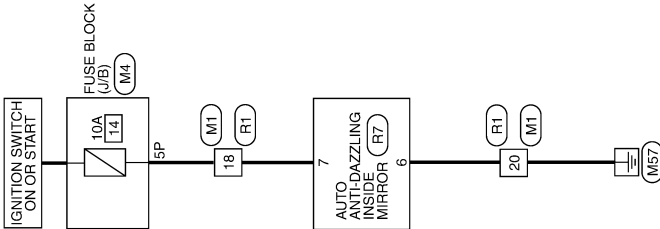

INSIDE MIRROR

AWLWA0127GB

INSIDE MIRROR

< COMPONENT DIAGNOSIS >

INSIDE MIRROR CONNECTORS

Connector No.	M1
Connector Name	WIRE TO WIRE
Connector Color	WHITE

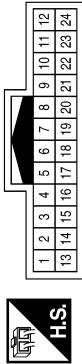

Terminal No.	Color of Wire	Signal Name
18	W/G	-
20	B	-

Connector No.	M4
Connector Name	FUSE BLOCK (J/B)
Connector Color	WHITE



Terminal No.	Color of Wire	Signal Name
5P	W/G	-

Connector No.	R1
Connector Name	WIRE TO WIRE
Connector Color	WHITE

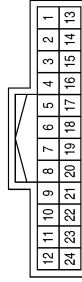

Terminal No.	Color of Wire	Signal Name
18	W/G	-
20	B	-

Connector No.	R7
Connector Name	AUTO ANTI-DAZZLING INSIDE MIRROR
Connector Color	WHITE

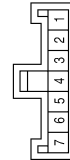

Terminal No.	Color of Wire	Signal Name
6	B	GND
7	W/G	IGN

ABLIA1867GB

A
B
C
D
E
F
G
H
I
J
K
M
N
O
P

MIR

PRECAUTIONS

< PRECAUTION >

PRECAUTION

PRECAUTIONS

Precaution for Supplemental Restraint System (SRS) "AIR BAG" and "SEAT BELT PRE-TENSIONER"

INFOID:000000005548998

The Supplemental Restraint System such as "AIR BAG" and "SEAT BELT PRE-TENSIONER", used along with a front seat belt, helps to reduce the risk or severity of injury to the driver and front passenger for certain types of collision. This system includes seat belt switch inputs and dual stage front air bag modules. The SRS system uses the seat belt switches to determine the front air bag deployment, and may only deploy one front air bag, depending on the severity of a collision and whether the front occupants are belted or unbelted. Information necessary to service the system safely is included in the SR and SB section of this Service Manual.

WARNING:

- To avoid rendering the SRS inoperative, which could increase the risk of personal injury or death in the event of a collision which would result in air bag inflation, all maintenance must be performed by an authorized NISSAN/INFINITI dealer.
- Improper maintenance, including incorrect removal and installation of the SRS, can lead to personal injury caused by unintentional activation of the system. For removal of Spiral Cable and Air Bag Module, see the SR section.
- Do not use electrical test equipment on any circuit related to the SRS unless instructed to in this Service Manual. SRS wiring harnesses can be identified by yellow and/or orange harnesses or harness connectors.

PRECAUTIONS WHEN USING POWER TOOLS (AIR OR ELECTRIC) AND HAMMERS

WARNING:

- When working near the Airbag Diagnosis Sensor Unit or other Airbag System sensors with the Ignition ON or engine running, DO NOT use air or electric power tools or strike near the sensor(s) with a hammer. Heavy vibration could activate the sensor(s) and deploy the air bag(s), possibly causing serious injury.
- When using air or electric power tools or hammers, always switch the Ignition OFF, disconnect the battery, and wait at least 3 minutes before performing any service.

PREPARATION

< SERVICE INFORMATION >

SERVICE INFORMATION

PREPARATION

Special Service Tool

INFOID:000000005268691

The actual shapes of Kent-Moore tools may differ from those of special service tools illustrated here.

Tool number (Kent-Moore No.) Tool name	Description
— (J-39570) Chassis ear	Locating the noise
— (J-43980) NISSAN Squeak and Rattle Kit	Repairing the cause of noise

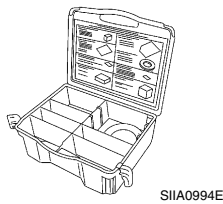
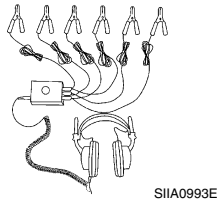

Commercial Service Tool

INFOID:000000005268692

(Kent-Moore No.) Tool name	Description
(J-39565) Engine ear	Locating the noise

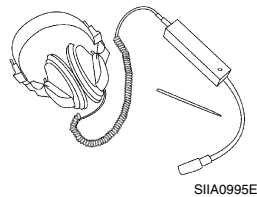

A
B
C
D
E
F
G
H
I
J
K
M
N
O
P

MIR

INSIDE MIRROR

< SERVICE INFORMATION >

INSIDE MIRROR

Removal and Installation

INFOID:000000005268693

INSIDE MIRROR

1. Remove screw and the inside mirror finisher.
2. Slide the mirror upward to remove.
3. Disconnect the connector.

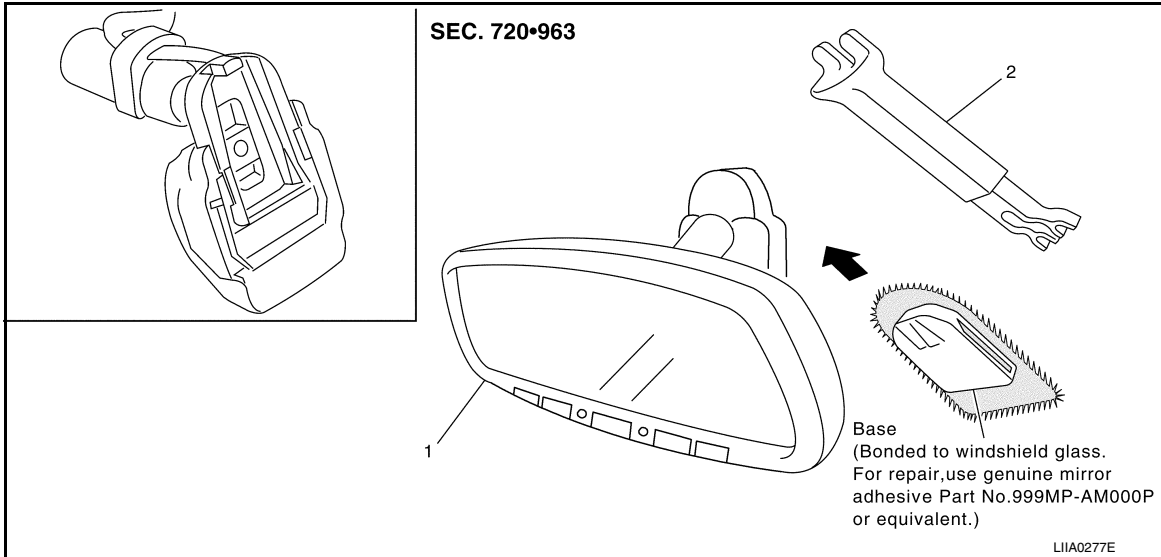

1. Inside mirror
2. Inside mirror finisher

Installation is in the reverse order of removal.

DOOR MIRROR

< SERVICE INFORMATION >

DOOR MIRROR

Door Mirror Assembly

INFOID:000000005268694

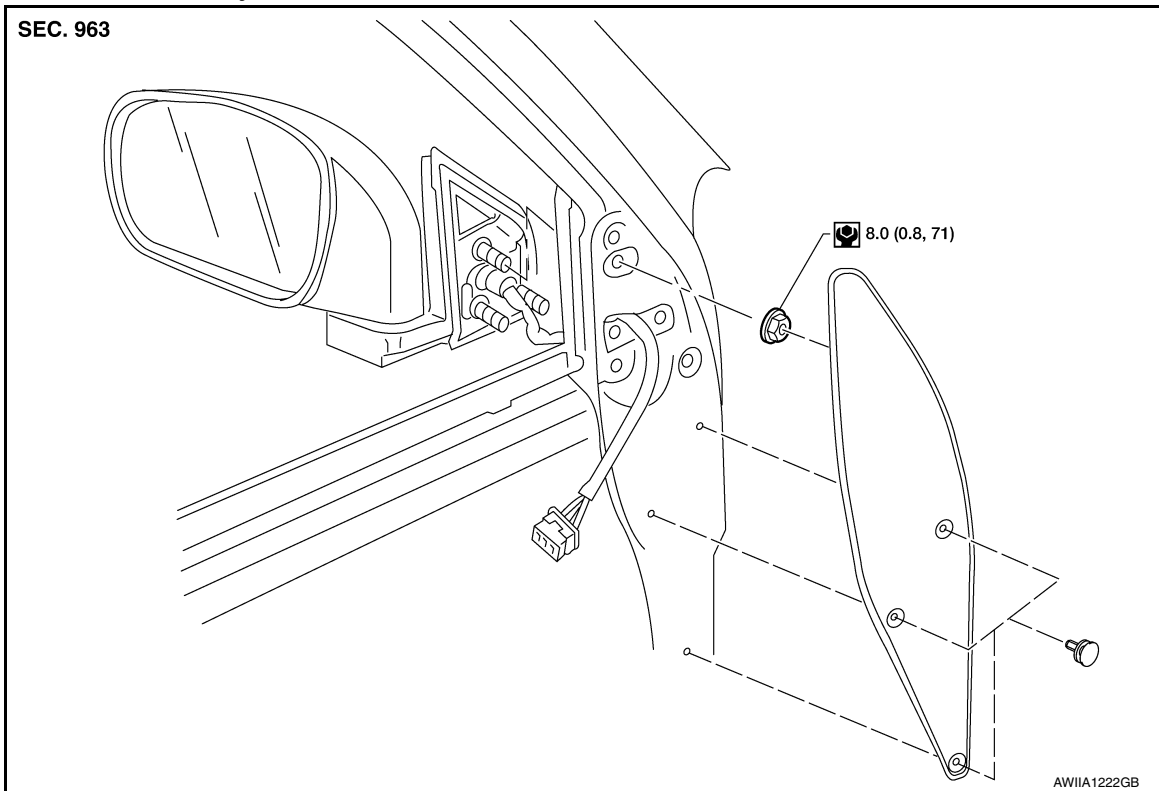

REMOVAL

NOTE:

Be careful not to damage the mirror bodies.

1. Remove the front door sash cover.
2. Remove the front door finisher. Refer to [INT-13, "Removal and Installation"](#).
3. Disconnect the door mirror harness connector.
4. Remove the nuts and the door mirror assembly.

INSTALLATION

Installation is in the reverse order of removal.

Door Mirror Glass

INFOID:000000005268695

REMOVAL AND INSTALLATION

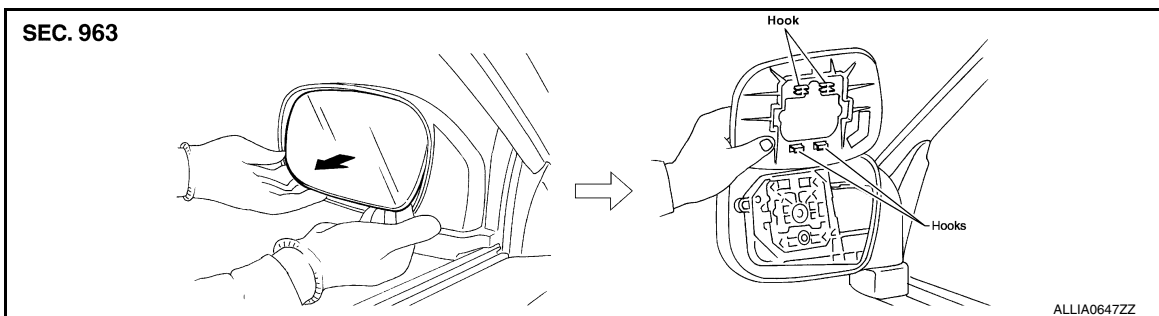

1. Angle the mirror fully up.
2. Remove the mirror.
 - Pull from the bottom to disengage the clips.
 - Continue to pivot the mirror upward from the bottom to separate the hooks.

Installation is in the reverse order of removal.

A
B
C
D
E
F
G
H
I
J
K
M
N
O
P

MIR

DOOR MIRROR

< DISASSEMBLY AND ASSEMBLY >

DISASSEMBLY AND ASSEMBLY

DOOR MIRROR

Mirror Actuator

INFOID:000000005268696

DISASSEMBLY AND ASSEMBLY

Disassembly

1. Remove the mirror glass. Refer to [MIR-13. "Door Mirror Glass"](#).
2. Remove the screws (A) and release the actuator from housing (B).

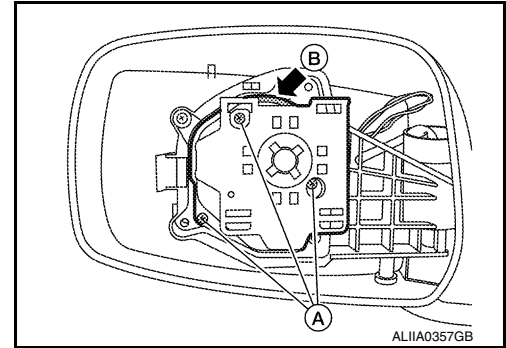

3. Disconnect the connectors (A) and remove the actuator (1).

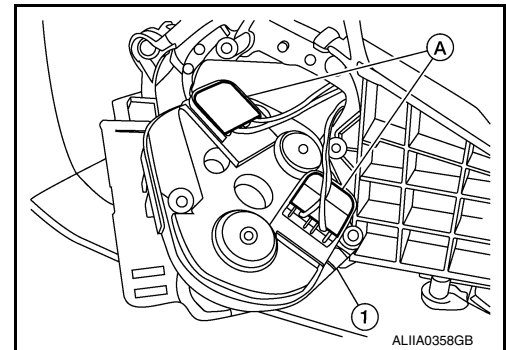

Assembly

Assembly is the reverse order of disassembly.