

A
CO
C
D
E
F
G
H
I
J
K
L
M
N
O
P

SECTION CO

ENGINE COOLING SYSTEM

CONTENTS

<p style="text-align: center;">VQ40DE</p> <p>PRECAUTION 2</p> <p>PRECAUTIONS 2</p> <p style="padding-left: 20px;">Precaution for Supplemental Restraint System (SRS) "AIR BAG" and "SEAT BELT PRE-TENSIONER"2</p> <p style="padding-left: 20px;">Precaution for Liquid Gasket2</p> <p>PREPARATION 4</p> <p>PREPARATION 4</p> <p style="padding-left: 20px;">Special Service Tool4</p> <p style="padding-left: 20px;">Commercial Service Tool4</p> <p>SYSTEM DESCRIPTION 6</p> <p>COOLING SYSTEM 6</p> <p style="padding-left: 20px;">Cooling Circuit6</p> <p style="padding-left: 20px;">Schematic7</p> <p>OVERHEATING CAUSE ANALYSIS 8</p> <p style="padding-left: 20px;">Troubleshooting Chart8</p> <p>PERIODIC MAINTENANCE10</p> <p>ENGINE COOLANT10</p> <p style="padding-left: 20px;">System Inspection10</p> <p style="padding-left: 20px;">Changing Engine Coolant12</p>	<p>REMOVAL AND INSTALLATION16</p> <p>RADIATOR16</p> <p style="padding-left: 20px;">Exploded View16</p> <p style="padding-left: 20px;">Removal and Installation16</p> <p>ENGINE COOLING FAN19</p> <p style="padding-left: 20px;">Exploded View19</p> <p style="padding-left: 20px;">Removal and Installation (Crankshaft driven type)...19</p> <p style="padding-left: 20px;">Removal and Installation (Motor driven type)20</p> <p>WATER PUMP22</p> <p style="padding-left: 20px;">Exploded View22</p> <p style="padding-left: 20px;">Removal and Installation22</p> <p>WATER INLET AND THERMOSTAT ASSEMBLY27</p> <p style="padding-left: 20px;">Exploded View27</p> <p style="padding-left: 20px;">Removal and Installation27</p> <p>WATER OUTLET AND WATER PIPING29</p> <p style="padding-left: 20px;">Exploded View29</p> <p style="padding-left: 20px;">Removal and Installation29</p> <p>SERVICE DATA AND SPECIFICATIONS (SDS)31</p> <p>SERVICE DATA AND SPECIFICATIONS (SDS)31</p> <p style="padding-left: 20px;">Standard and Limit31</p>
---	--

PRECAUTION

PRECAUTIONS

Precaution for Supplemental Restraint System (SRS) "AIR BAG" and "SEAT BELT PRE-TENSIONER"

INFOID:000000006835139

The Supplemental Restraint System such as "AIR BAG" and "SEAT BELT PRE-TENSIONER", used along with a front seat belt, helps to reduce the risk or severity of injury to the driver and front passenger for certain types of collision. This system includes seat belt switch inputs and dual stage front air bag modules. The SRS system uses the seat belt switches to determine the front air bag deployment, and may only deploy one front air bag, depending on the severity of a collision and whether the front occupants are belted or unbelted. Information necessary to service the system safely is included in the SR and SB section of this Service Manual.

WARNING:

- To avoid rendering the SRS inoperative, which could increase the risk of personal injury or death in the event of a collision which would result in air bag inflation, all maintenance must be performed by an authorized NISSAN/INFINITI dealer.
- Improper maintenance, including incorrect removal and installation of the SRS, can lead to personal injury caused by unintentional activation of the system. For removal of Spiral Cable and Air Bag Module, see the SR section.
- Do not use electrical test equipment on any circuit related to the SRS unless instructed to in this Service Manual. SRS wiring harnesses can be identified by yellow and/or orange harnesses or harness connectors.

PRECAUTIONS WHEN USING POWER TOOLS (AIR OR ELECTRIC) AND HAMMERS

WARNING:

- When working near the Airbag Diagnosis Sensor Unit or other Airbag System sensors with the Ignition ON or engine running, DO NOT use air or electric power tools or strike near the sensor(s) with a hammer. Heavy vibration could activate the sensor(s) and deploy the air bag(s), possibly causing serious injury.
- When using air or electric power tools or hammers, always switch the Ignition OFF, disconnect the battery, and wait at least 3 minutes before performing any service.

Precaution for Liquid Gasket

INFOID:000000006255434

REMOVAL OF LIQUID GASKET SEALING

- After removing nuts and bolts, separate the mating surface, using Tool and remove old liquid gasket sealing.

Tool number : KV10111100 (J-37228)

CAUTION:

Be careful not to damage the mating surfaces.

- Tap (1) Tool to insert it, and then slide (2) it by tapping on the side as shown.
- In areas where Tool is difficult to use, use plastic hammer to lightly tap the parts, to remove it.

CAUTION:

If for some unavoidable reason suitable tool such as screwdriver is used, be careful not to damage the mating surfaces.

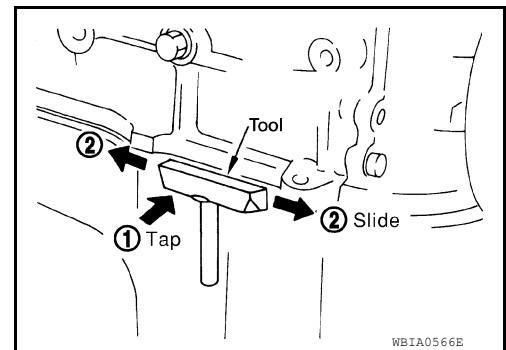

LIQUID GASKET APPLICATION PROCEDURE

PRECAUTIONS

[VQ40DE]

< PRECAUTION >

1. Remove the old liquid gasket adhering to the gasket application surface and the mating surface using suitable tool.
 - Remove the liquid gasket completely from the groove of the liquid gasket application surface, bolts, and bolt holes.
2. Thoroughly clean the mating surfaces and remove adhering moisture, grease and foreign material.

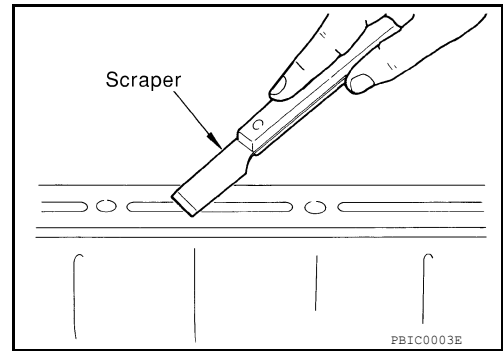

3. Attach the liquid gasket tube to the Tool.

Tool number : WS39930000 (—)

Use Genuine RTV Silicone Sealant or equivalent. Refer to [GI-15, "Recommended Chemical Products and Sealants"](#).

4. Apply the liquid gasket without breaks to the specified location with the specified dimensions.

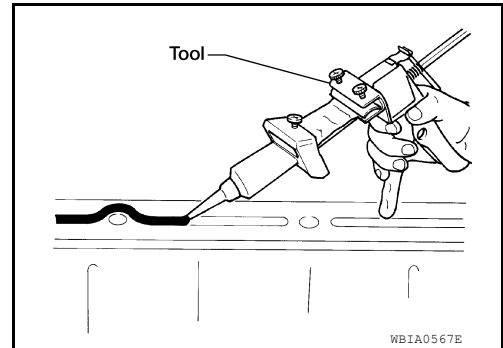

- If there is a groove for the liquid gasket application, apply the liquid gasket to the groove.
- As for the bolt holes, normally apply the liquid gasket inside the holes. If specified in the procedure, it should also be applied outside the holes.
- Within five minutes of liquid gasket application, install the mating component.
- If the liquid gasket protrudes, wipe it off immediately.
- Do not retighten after the installation.
- Wait 30 minutes or more after installation before refilling the engine with engine oil and engine coolant.

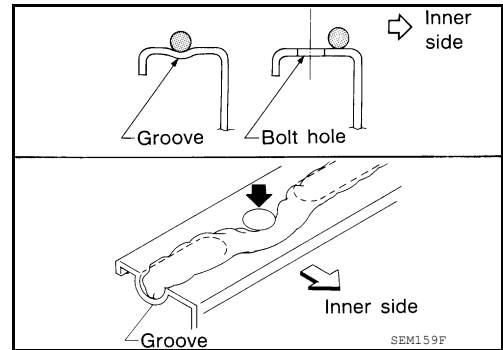

CAUTION:

Carefully follow all of the warnings, cautions, notes, and procedures contained in this manual.

PREPARATION

< PREPARATION >

[VQ40DE]

PREPARATION

PREPARATION

Special Service Tool

INFOID:000000006255435

The actual shapes of Kent-Moore tools may differ from those of special service tools illustrated here.

Tool number (Kent-Moore No.) Tool name	Description
KV10111100 (J-37228) Seal cutter	Removing chain tensioner cover and water pump cover
WS39930000 (—) Tube presser	Pressing the tube of liquid gasket
EG17650301 (J-33984-A) Radiator cap tester adapter	Adapting radiator cap tester to radiator cap and radiator filler neck a: 28 (1.10) dia. b: 31.4 (1.236) dia. c: 41.3 (1.626) dia. Unit: mm (in)
KV991J0070 (J-45695) Coolant refill tool	Filling cooling system
KV991J0010 (J-23688) Engine coolant refractometer	Checking concentration of ethylene glycol in engine coolant

Commercial Service Tool

INFOID:000000006255436

PREPARATION

< PREPARATION >

[VQ40DE]

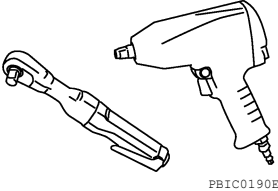
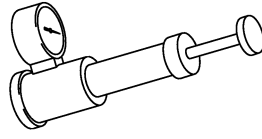
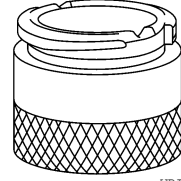
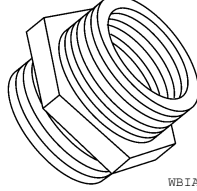
Tool name	Description
<p>Power tool</p>  <p>PBIC0190E</p>	<p>Loosening bolts and nuts</p>
<p>Radiator cap tester</p>  <p>PBIC1982E</p>	<p>Checking radiator and radiator cap</p>
<p>Coolant system tester adapter</p>  <p>WBIA0408E</p>	<p>Adapting radiator cap tester to reservoir filler neck</p>
<p>Coolant system tester adapter</p>  <p>WBIA0409E</p>	<p>Adapting radiator cap tester to reservoir cap</p>

A

CO

C

D

E

F

G

H

I

J

K

L

M

N

O

P

SYSTEM DESCRIPTION

COOLING SYSTEM

Cooling Circuit

INFOID:000000006255437

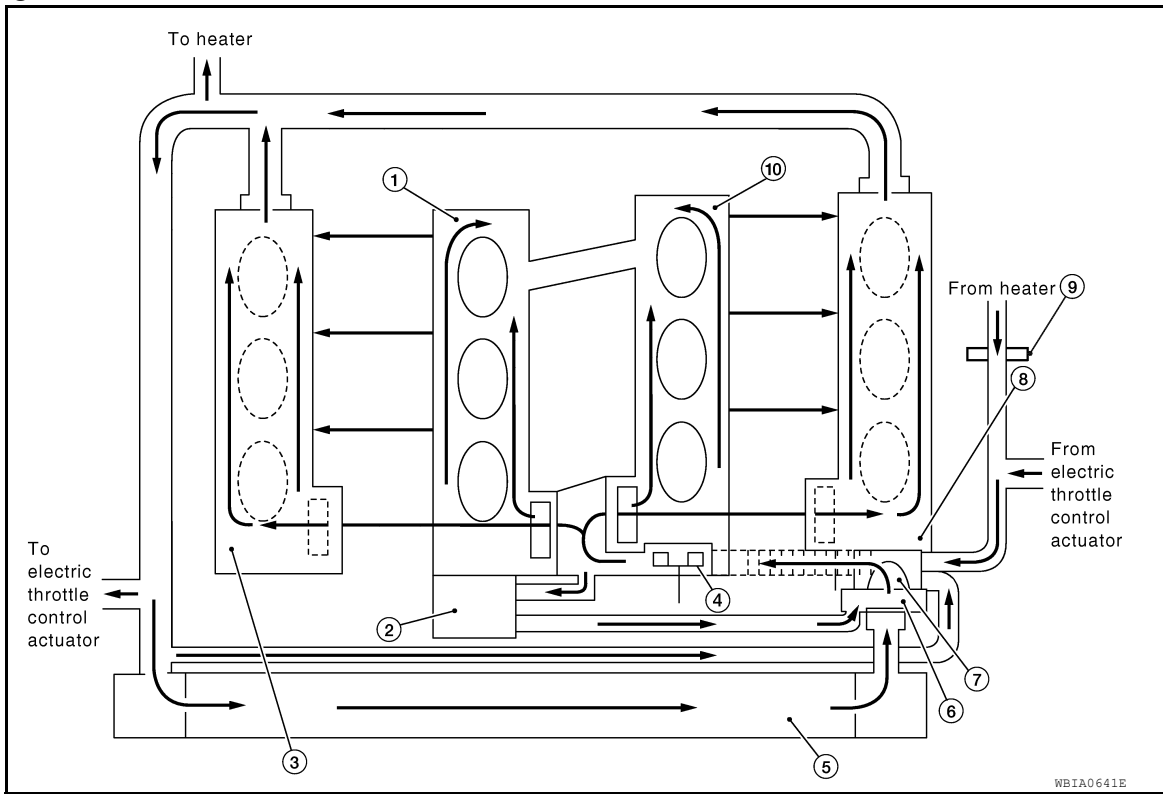

- | | | |
|-------------------------|-----------------------|-----------------------|
| 1. Cylinder block (RH) | 2. Oil cooler | 3. Cylinder head (RH) |
| 4. Water pump | 5. Radiator | 6. Water inlet |
| 7. Thermostat | 8. Cylinder head (LH) | 9. Heater pump |
| 10. Cylinder block (LH) | | |

COOLING SYSTEM

< SYSTEM DESCRIPTION >

[VQ40DE]

Schematic

INFOID:000000006255438

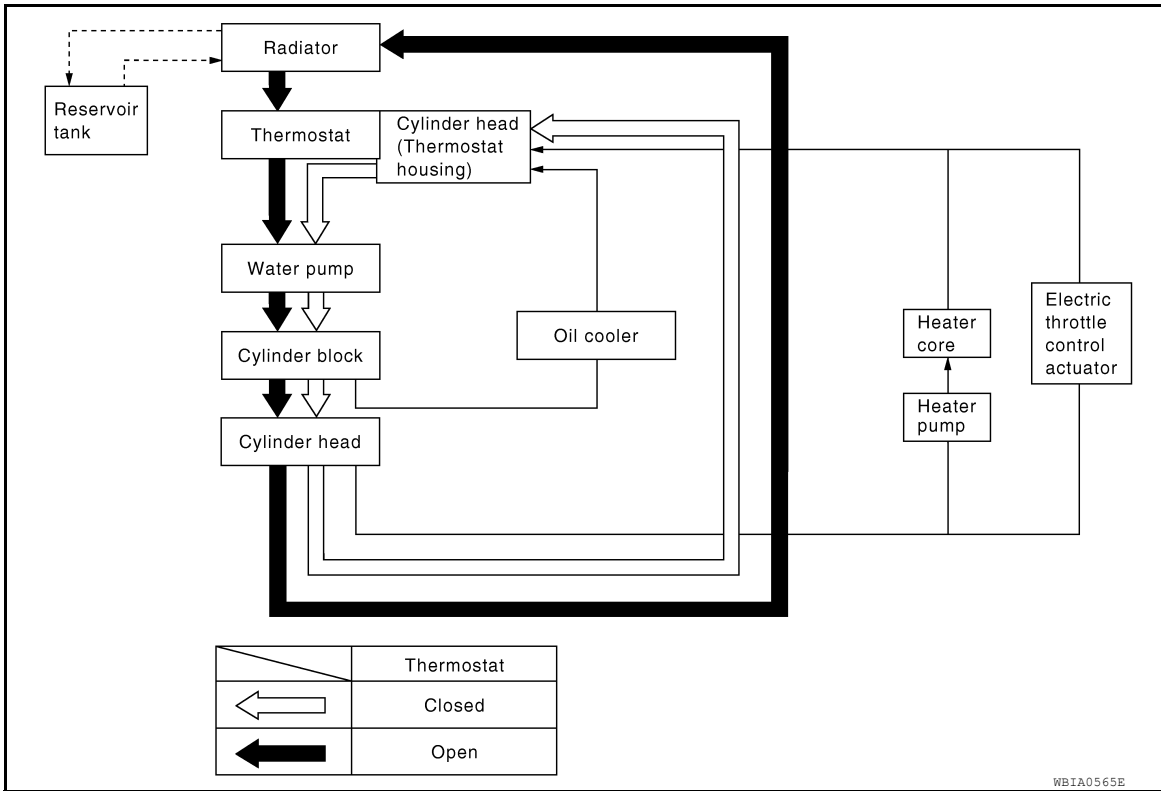

A

CO

C

D

E

F

G

H

I

J

K

L

M

N

O

P

OVERHEATING CAUSE ANALYSIS

< SYSTEM DESCRIPTION >

[VQ40DE]

OVERHEATING CAUSE ANALYSIS

Troubleshooting Chart

INFOID:000000006255439

		Symptom		Check items	
Cooling system parts malfunction	Poor heat transfer	Water pump malfunction	Worn or loose drive belt	—	
		Thermostat stuck closed	Thermostat		
		Damaged fins	Dust contamination or paper clogging		
			Physical damage		
		Clogged radiator cooling tube	Excess foreign material (rust, dirt, sand, etc.)		
	Reduced air flow	Cooling fan does not operate	Fan assembly	—	
		High resistance to fan rotation			
		Damaged fan blades			
	Damaged radiator shroud	—	Radiator shroud	—	
	Improper engine coolant mixture ratio	—	Engine coolant viscosity	—	
	Poor engine coolant quality	—		—	
	Insufficient engine coolant	Engine coolant leaks	Cooling hose	Loose clamp	
				Cracked hose	
			Heater pump	Physical damage	
			Water pump	Poor sealing	
			Radiator cap	Loose	
				Poor sealing	
Radiator		O-ring for damage, deterioration or improper fitting			
		Cracked radiator tank			
	Cracked radiator core				
Reservoir tank	Cracked reservoir tank				
Overflowing reservoir tank	Exhaust gas leaks into cooling system	Cylinder head deterioration			
		Cylinder head gasket deterioration			

OVERHEATING CAUSE ANALYSIS

< SYSTEM DESCRIPTION >

[VQ40DE]

	Symptom		Check items		
Except cooling system parts malfunction	—	Overload on engine	Abusive driving	High engine rpm under no load	A
				Driving in low gear for extended time	CO
				Driving at extremely high speed	
			Powertrain system malfunction		C
			Installed improper size wheels and tires	—	D
			Dragging brakes		
			Improper ignition timing		E
	Blocked or restricted air flow	Blocked bumper	Mud contamination or paper clogging		
		Blocked radiator grille	Installed car brassiere		F
			Mud contamination or paper clogging	—	
		Blocked radiator	Blocked air flow		G
		Blocked condenser			
Installed large fog lamp					

A
CO
C
D
E
F
G
H
I
J
K
L
M
N
O
P

PERIODIC MAINTENANCE

ENGINE COOLANT

System Inspection

INFOID:000000006255440

WARNING:

- Never remove the radiator/reservoir cap when the engine is hot. Serious burns could occur from high pressure fluid escaping from the radiator or reservoir.
- Wrap a thick cloth around the cap. Slowly push down and turn it a quarter turn to allow built-up pressure to escape. Carefully remove the cap by pushing down and turning it all the way.

CHECKING COOLING SYSTEM HOSES

Check hoses for the following:

- Improper attachment
- Leaks
- Cracks
- Damage
- Loose connections
- Chafing
- Deterioration

CHECKING RESERVOIR LEVEL

- Check if the engine coolant reservoir tank level is within MIN to MAX when the engine is cool.
- Adjust engine coolant level as necessary.

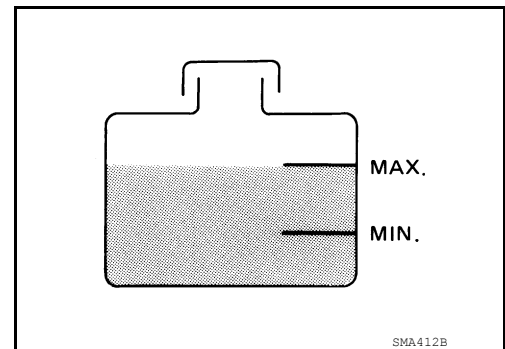

CHECKING COOLING SYSTEM FOR LEAKS

WARNING:

Never remove the radiator/reservoir cap when the engine is hot. Serious burns could occur from high pressure coolant escaping from the radiator or reservoir.

To check for leakage, apply pressure to the cooling system at the reservoir filler neck using suitable tool and Tool.

Tool number : EG17650301 (J-33984-A)

Testing pressure : 137 kPa (1.4 kg/cm², 20 psi)

CAUTION:

Higher pressure than specified may cause radiator damage.

NOTE:

In case that engine coolant decreases, replenish cooling system with engine coolant.

If any concerns are found, repair or replace damaged parts.

CHECKING RESERVOIR CAP

1. Inspect the reservoir cap.
 - Replace the cap if the metal plunger cannot be seen around the edge of the black rubber gasket.
 - Replace the cap if deposits of waxy residue or other foreign material are on the black rubber gasket or the metal retainer.

NOTE:

Thoroughly wipe out the reservoir filler neck to remove any waxy residue or foreign material.

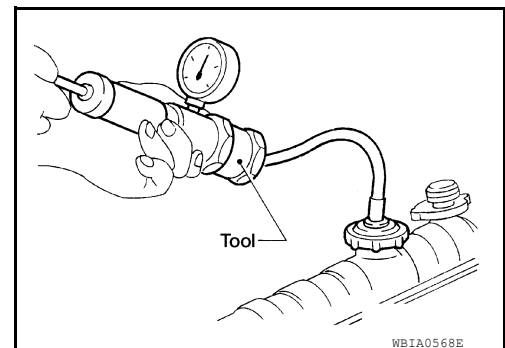

ENGINE COOLANT

[VQ40DE]

< PERIODIC MAINTENANCE >

2. Pull the negative-pressure valve to open it and check that it closes completely when released.
 - Check that there is no dirt or damage on the valve seat of the reservoir cap negative-pressure valve.
 - Check that there are no abnormalities in the opening and closing conditions of the negative-pressure valve.

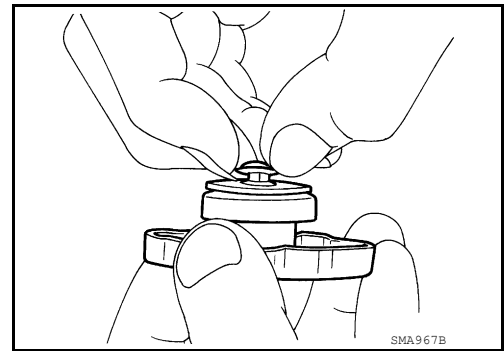

3. Check reservoir cap relief pressure using suitable tool and Tool.

Tool number : EG17650301 (J-33984-A)

Standard: 98 – 118 kPa (1.0 – 1.2 kg/cm², 14 – 17 psi)

NOTE:

- Apply engine coolant to the cap seal surface.
- Replace the reservoir cap if there is any damage in the negative-pressure valve, or if the open-valve pressure is outside of the limit.

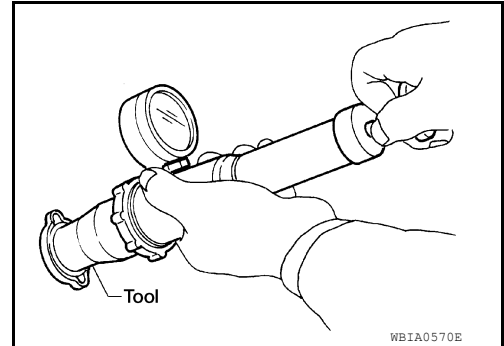

CHECKING RADIATOR CAP

- Check valve seat of radiator cap.
- Replace the cap if the metal plunger cannot be seen around the edge of the black rubber gasket.
- Replace the cap if deposits of waxy residue or other foreign material are on the black rubber gasket or the metal retainer.

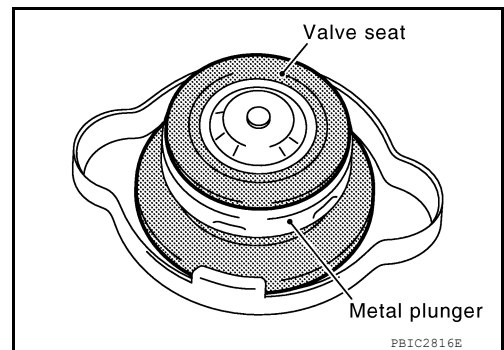

- Pull the negative-pressure valve to open it and check that it closes completely when released.
- Check that there is no dirt or damage on the valve seat of the radiator cap negative-pressure valve.
- Make sure that the valve operates properly while opening and closing.

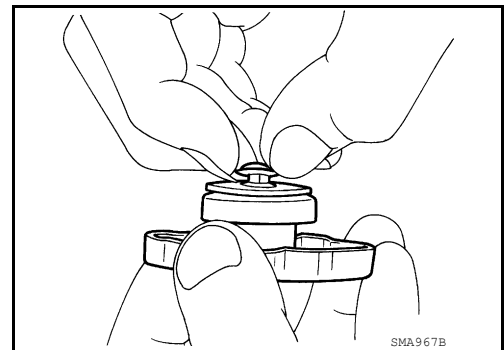

A
CO
C
D
E
F
G
H
I
J
K
L
M
N
O
P

ENGINE COOLANT

< PERIODIC MAINTENANCE >

[VQ40DE]

- Check radiator cap relief pressure using suitable tool and Tool.

Tool number : EG17650301 (J-33984-A)

Standard: 98 – 118 kPa (1.0 – 1.2 kg/cm², 14 – 17 psi)

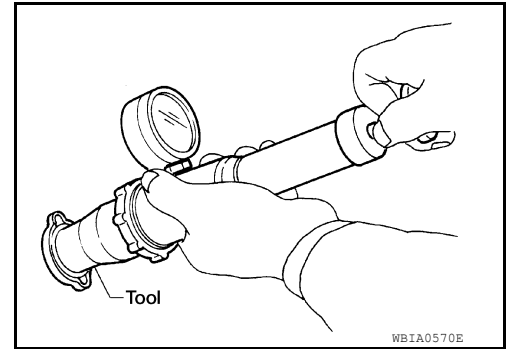

- When connecting the radiator cap to the tester, apply water or coolant to the cap seal surface.
- Replace radiator cap if there is an abnormality in the negative-pressure valve, or if the open-valve pressure is outside of the standard values.
- Replace the radiator cap if it exceeds the specifications in the above tests.

CAUTION:

When installing the radiator cap, thoroughly wipe out the radiator filler neck to remove waxy residue or foreign material.

CHECKING RADIATOR

Check radiator for mud or clogging. If necessary, clean radiator as follows.

CAUTION:

- **Be careful not to bend or damage the radiator fins.**
 - **When radiator is cleaned without removal, remove all surrounding parts such as cooling fan shroud and horns. Then tape the harness and electrical connectors to prevent water from entering.**
1. Spray water to the back side of the radiator core using a side to side motion from the top down.
 2. Stop spraying when debris no longer flows from radiator core.
 3. Blow air into the back side of radiator core using a side to side motion from the top down.
 - Use compressed air lower than 490 kPa (5 kg/cm², 71 psi) and keep distance more than 30 cm (11.8 in).
 4. Continue to blow air until no water sprays out.
 5. Check for coolant leaks. Repair as necessary.

Changing Engine Coolant

INFOID:000000006255441

WARNING:

- **To avoid being scalded, never change the coolant when the engine is hot.**
- **Wrap a thick cloth around the cap to carefully remove the cap. First, turn the cap a quarter of a turn to release any built-up pressure, then push down and turn the cap all the way to remove it.**

DRAINING ENGINE COOLANT

1. Turn ignition switch ON and set temperature control lever all the way to HOT position or the highest temperature position. Wait 10 seconds and turn ignition switch OFF.
2. Remove the engine under cover. Refer to [EXT-15, "Removal and Installation"](#).
3. Open the radiator drain plug at the bottom of the radiator, and remove the reservoir cap. This is the only step required when partially draining the cooling system (radiator only).

CAUTION:

- **Do not to allow the coolant to contact the drive belts.**
- **Perform this step when engine is cold.**

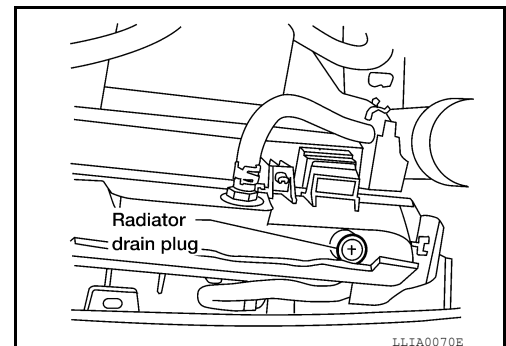

ENGINE COOLANT

[VQ40DE]

< PERIODIC MAINTENANCE >

- When draining all of the coolant in the system for engine removal or repair, it is necessary to drain the cylinder block. Remove the cylinder block drain plugs (A), (B), (C), (D) and block heater if equipped, to drain the cylinder block as shown.

CAUTION:

Do not reuse copper sealing washers.

NOTE:

For Canada, the (D) cylinder block drain plug as shown, is not a cylinder block drain plug but a block heater.

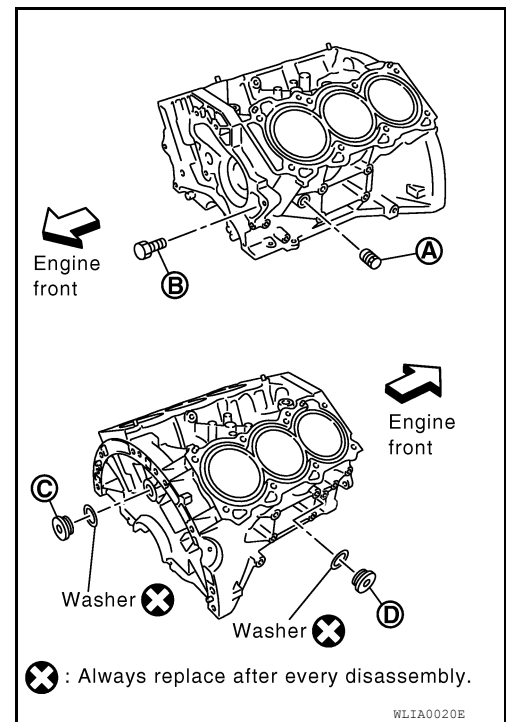

- Remove the reservoir tank to drain the engine coolant, then clean the reservoir tank before installing it.
- Check the drained coolant for contaminants such as rust, corrosion or discoloration. If the coolant is contaminated, flush the engine cooling system. Follow the "Flushing Cooling System" procedure.

REFILLING ENGINE COOLANT

- Close the radiator drain plug. Install the reservoir tank, cylinder block drain plugs (A), (B), (C), (D) and block heater if equipped, if removed for a total system drain or for engine removal or repair.

- The radiator must be completely empty of coolant and water.
- Apply sealant to the threads of the cylinder block drain plugs (A), (B), (C), (D). Use Genuine High Performance Thread Sealant or equivalent. Refer to [GI-15, "Recommended Chemical Products and Sealants"](#).
- Tighten each plug to the specified torque. Refer to [EM-104, "Disassembly and Assembly"](#).

CAUTION:

Do not reuse copper sealing washers.

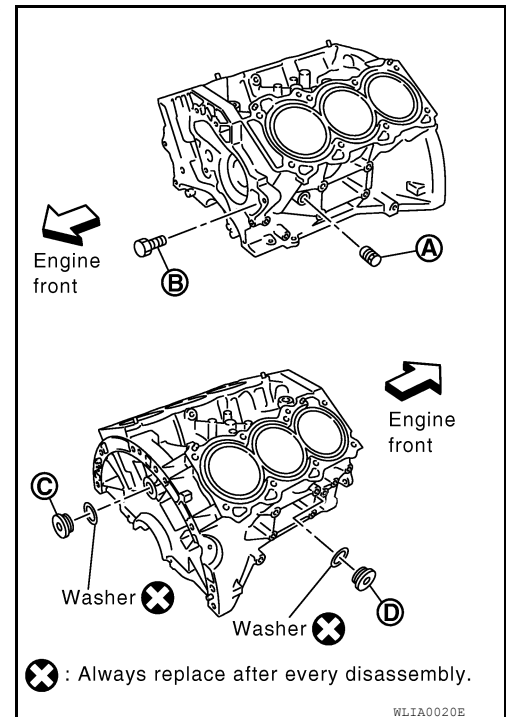

- Set the vehicle heater controls to the full HOT and heater ON position. Turn the vehicle ignition ON with the engine OFF as necessary to activate the heater mode.
- Remove the vented reservoir cap and replace it with a non-vented reservoir cap before filling the cooling system.

ENGINE COOLANT

[VQ40DE]

< PERIODIC MAINTENANCE >

4. Install the Tool by installing the radiator cap adapter onto the radiator neck opening. Then attach the gauge body assembly with the refill tube and the venturi assembly to the radiator cap adapter.

Tool number : KV991J0070 (J-45695)

5. Insert the refill hose into the coolant mixture container that is placed at floor level. Make sure the ball valve is in the closed position.

- Use recommended coolant or equivalent.

Refer to [MA-13, "Fluids and Lubricants"](#).

CAUTION:

Never use any cooling system additives such as radiator sealer. Additives may clog the cooling system and cause damage to the engine, transmission and/or cooling system.

Cooling system capacity (with reservoir) : Refer to [MA-13, "Fluids and Lubricants"](#).

6. Install an air hose to the venturi assembly, the air pressure must be within specification.

Compressed air supply pressure : 549 - 824 kPa (5.6 - 8.4 kg/cm², 80 - 119 psi)

CAUTION:

The compressed air supply must be equipped with an air dryer.

7. The vacuum gauge will begin to rise and there will be an audible hissing noise. During this process open the ball valve on the refill hose slightly. Rising coolant will be visible in the refill hose. After the refill hose is full of coolant, close the ball valve. This will purge air trapped in the refill hose.

8. Continue to draw the vacuum until the gauge reaches 28 inches of vacuum. The gauge may not reach 28 inches in high altitude locations. Refer to the following vacuum specifications.

Altitude above sea level	Vacuum gauge reading
0 - 100 m (328 ft)	: 28 inches of vacuum
300 m (984 ft)	: 27 inches of vacuum
500 m (1,641 ft)	: 26 inches of vacuum
1,000 m (3,281 ft)	: 24 - 25 inches of vacuum

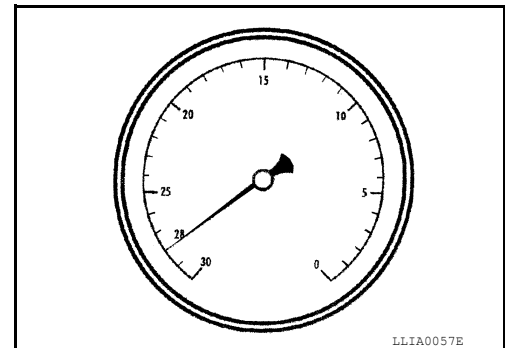
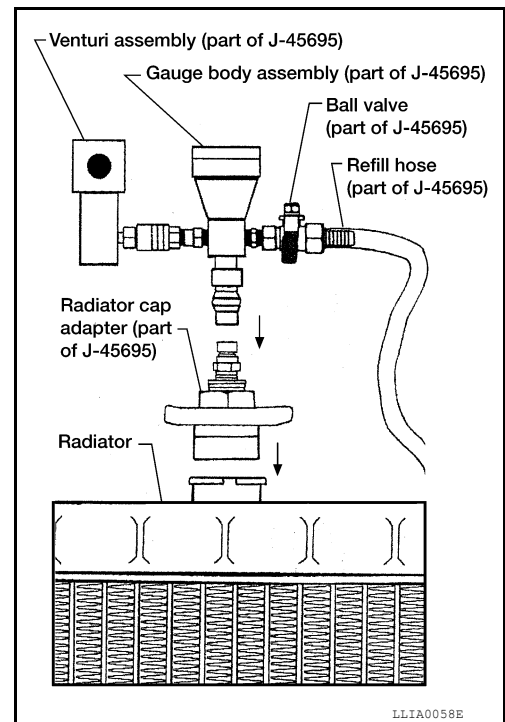

9. When the vacuum gauge has reached the specified amount, disconnect the air hose and wait 20 seconds to see if the system loses vacuum. If the vacuum level drops, perform necessary repairs to the system and repeat steps 6 - 8 to bring the vacuum to the specified amount. Recheck for leaks.

10. Place the coolant container (with the refill hose inserted) at the same level as the top of the radiator. Then open the ball valve on the refill hose so the coolant will be drawn up to fill the cooling system. The cooling system is full when the vacuum gauge reads zero.

CAUTION:

Do not allow the coolant container to get too low when filling, to avoid air from being drawn into the cooling system.

11. Remove the Tool from the radiator neck opening and install the radiator cap.
12. Remove the non-vented reservoir cap.
13. Fill the cooling system reservoir tank to the specified level. Run the engine to warm up the cooling system and top up the system as necessary before installing the vented reservoir cap.
14. Install the engine under cover. Refer to [EXT-15, "Removal and Installation"](#).

FLUSHING COOLING SYSTEM

ENGINE COOLANT

< PERIODIC MAINTENANCE >

[VQ40DE]

1. Drain the water from the engine cooling system. Refer to [CO-12. "Changing Engine Coolant"](#).
2. Fill the radiator and the reservoir tank (to the "MAX" line), with water. Reinstall the radiator cap and leave the vented reservoir cap off.
3. Run the engine until it reaches normal operating temperature.
4. Press the engine accelerator two or three times under no-load.
5. Stop the engine and wait until it cools down.
6. Drain the water from the engine cooling system. Refer to [CO-12. "Changing Engine Coolant"](#).
7. Repeat steps 2 through 6 until clear water begins to drain from the radiator.

A

CO

C

D

E

F

G

H

I

J

K

L

M

N

O

P

RADIATOR

< REMOVAL AND INSTALLATION >

[VQ40DE]

REMOVAL AND INSTALLATION

RADIATOR

Exploded View

INFOID:000000006255442

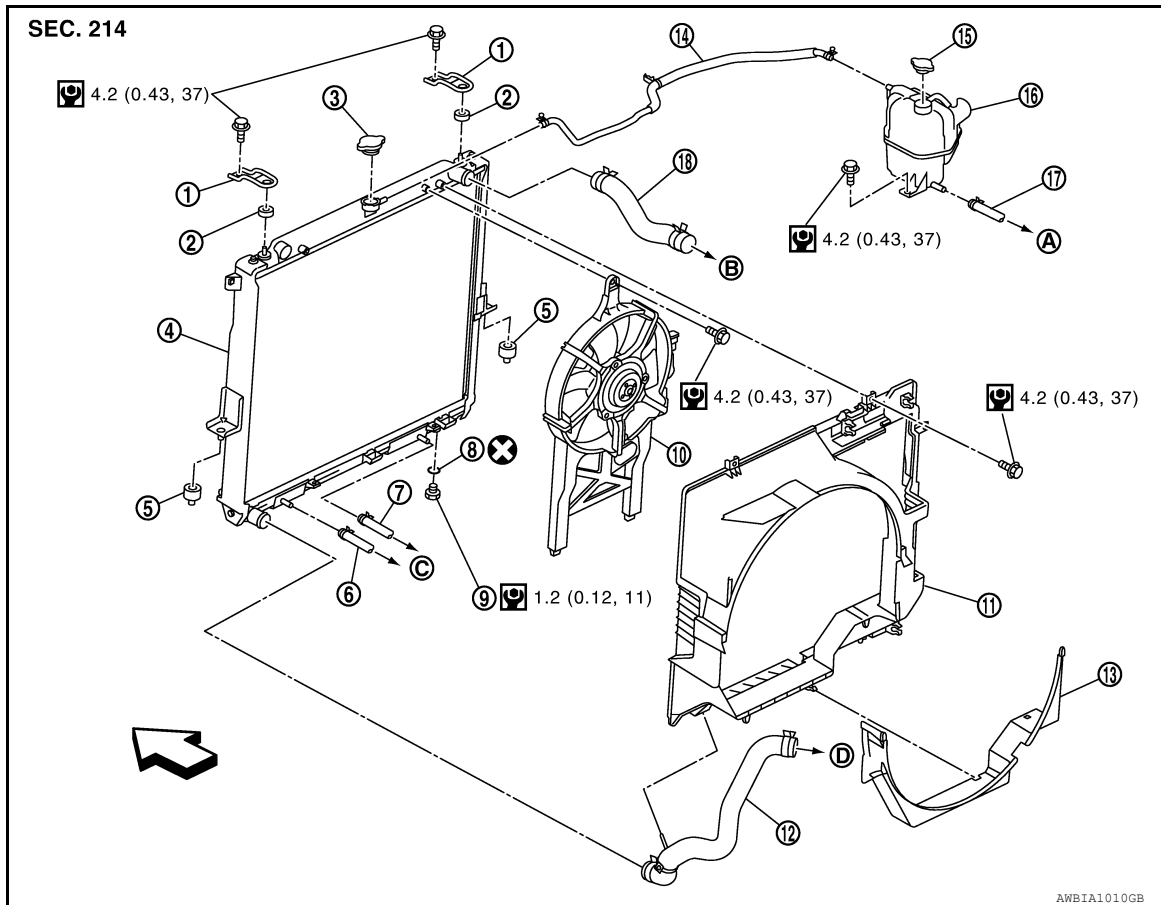

- | | | |
|--|-----------------------------|---------------------------|
| 1. Radiator mounting bracket | 2. Mounting rubber (upper) | 3. Radiator cap |
| 4. Radiator | 5. Mounting rubber (lower) | 6. A/T fluid cooler hose |
| 7. A/T fluid cooler hose (if equipped) | 8. O-ring | 9. Drain plug |
| 10. Cooling fan assembly (Motor driven type) | 11. Radiator shroud (upper) | 12. Radiator hose (lower) |
| 13. Radiator shroud (lower) | 14. Reservoir tank hose | 15. Reservoir tank cap |
| 16. Reservoir tank | 17. Water hose | 18. Radiator hose (upper) |
| A. To heater return tube | B. To water pipe | C. To A/T cooler tube |
| D. To water inlet and thermostat assembly | ← Vehicle front | |

Removal and Installation

INFOID:000000006255443

WARNING:

Never remove the radiator cap when the engine is hot. Serious burns could occur from high pressure engine coolant escaping from the radiator. Wrap a thick cloth around the cap. Slowly turn it a quarter of a turn to release built-up pressure. Carefully remove radiator cap by turning it all the way.

NOTE:

When removing components such as hoses, tubes/lines, etc., cap or plug openings to prevent fluid from spilling.

REMOVAL

1. Remove engine under cover. Refer to [EXT-15, "Removal and Installation"](#).

RADIATOR

[VQ40DE]

< REMOVAL AND INSTALLATION >

2. Drain engine coolant from radiator. Refer to [CO-10](#).
CAUTION:
 - Perform this step when engine is cold.
 - Do not spill engine coolant on drive belts.
3. Remove air duct and resonator assembly and air cleaner case upper. Refer to [EM-24, "Removal and Installation"](#).
4. Remove reservoir tank hose from the radiator.
5. Remove radiator hoses (upper and lower).
CAUTION:
Be careful not to allow engine coolant to contact drive belts.
6. Disconnect A/T fluid cooler hoses (if equipped).
7. Remove engine cooling fan (Motor driven type). Refer to [CO-20, "Removal and Installation \(Motor driven type\)"](#).
8. Remove front grille. Refer to [EXT-19, "Removal and Installation"](#).
9. Remove the upper radiator mounting bracket bolts.

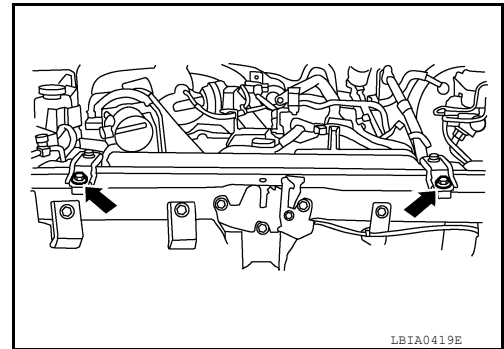

10. Remove the two A/C condenser bolts.

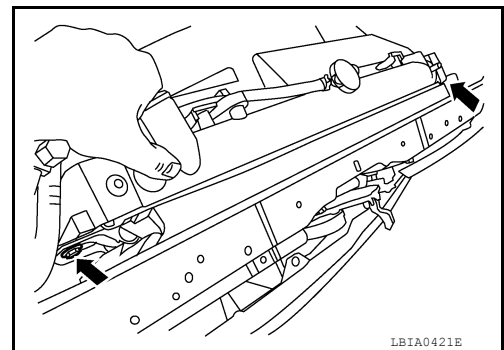

11. Remove radiator as follows:

CAUTION:

Do not damage or scratch A/C condenser and radiator core when removing.

- a. Lift and pull radiator rearward to disengage mounting rubber (lower) from radiator core support center.

CAUTION:

Because A/C condenser is attached to the front-lower portion of radiator, moving it in the rear direction should be at a minimum.

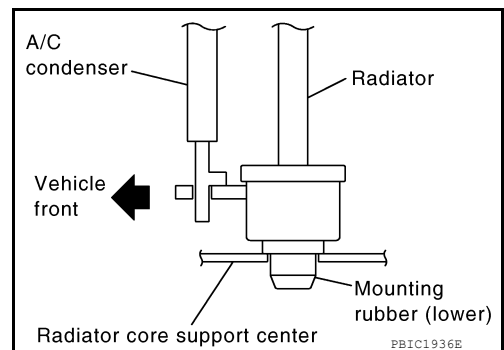

RADIATOR

[VQ40DE]

< REMOVAL AND INSTALLATION >

- b. Lift A/C condenser up and remove radiator after disengaging the fitting at front-bottom surface.

CAUTION:

Lifting A/C condenser should be minimum to prevent a load to A/C piping.

- c. After removing radiator, put A/C condenser on radiator core support center to prevent a load to A/C piping, and temporarily secure it with a suitable device.

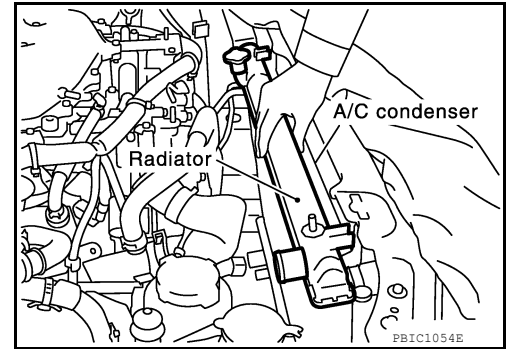

INSTALLATION

Installation is in the reverse order of removal.

INSPECTION AFTER INSTALLATION

- Check for engine coolant leaks. Refer to [CO-10, "System Inspection"](#).
- Start and warm up engine. Visually check for coolant and A/T fluid (if equipped) leaks. Repair as necessary.
- Check and adjust engine coolant level and A/T fluid (if equipped). Refer to [MA-13, "Fluids and Lubricants"](#).

ENGINE COOLING FAN

< REMOVAL AND INSTALLATION >

[VQ40DE]

ENGINE COOLING FAN

Exploded View

INFOID:000000006255445

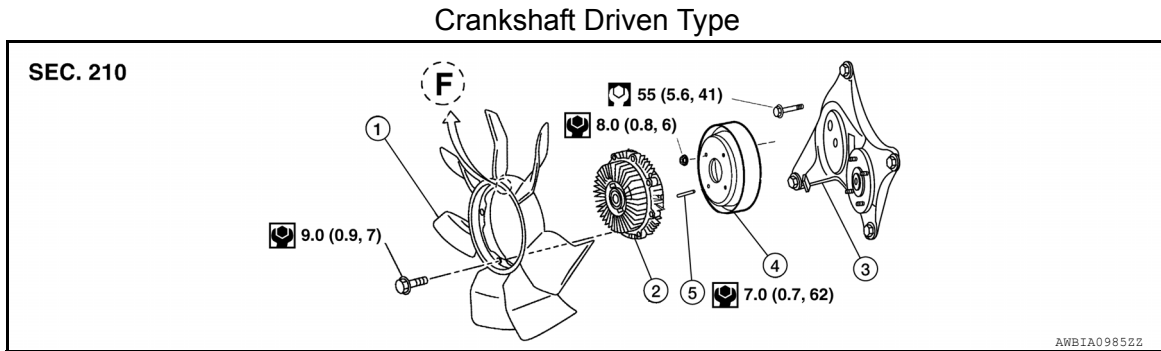

- | | | |
|-----------------------|-----------------|----------------|
| 1. Cooling fan | 2. Fan coupling | 3. Fan bracket |
| 4. Cooling fan pulley | 5. Stud | |

Removal and Installation (Crankshaft driven type)

INFOID:000000006255446

WARNING:

Never remove the radiator cap when the engine is hot. Serious burns could occur from high pressure engine coolant escaping from the radiator. Wrap a thick cloth around the cap. Slowly turn it a quarter of a turn to release built-up pressure. Carefully remove radiator cap by turning it all the way.

REMOVAL

1. Remove the engine cooling fan (Motor driven type). Refer to [CO-20. "Removal and Installation \(Motor driven type\)"](#).
2. Remove the drive belt. Refer to [EM-13. "Removal and Installation"](#).
3. Remove the cooling fan.
4. Remove the fan coupling, if necessary.
5. Remove the cooling fan pulley, if necessary.
6. Remove the drive belt auto tensioner, if necessary. Refer to [EM-14. "Drive Belt Auto Tensioner and Idler Pulley"](#).
7. Remove the fan bracket, if necessary.

INSPECTION AFTER REMOVAL

Fan Coupling

- Inspect fan coupling for oil leakage and bimetal conditions.
- If there are any concerns, replace the fan coupling.

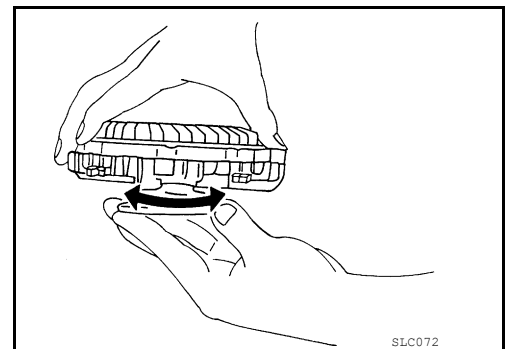

Fan Bracket

ENGINE COOLING FAN

[VQ40DE]

< REMOVAL AND INSTALLATION >

- Visually check that there is no significant looseness in the fan bracket shaft, and that it turns smoothly by hand.
- If there are any unusual concerns, replace the fan bracket assembly.

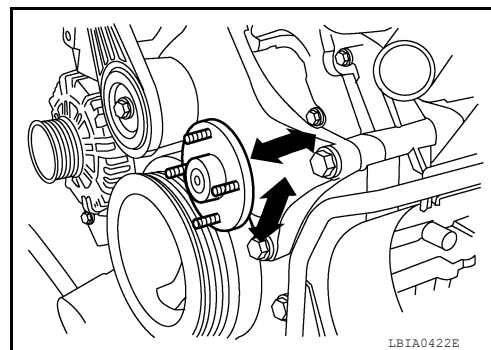

INSTALLATION

Installation is in the reverse order of removal.

- Install cooling fan with its front mark "F" facing front of engine. Refer to [CO-19, "Removal and Installation \(Crankshaft driven type\)"](#).

INSPECTION AFTER INSTALLATION

- Check for engine coolant leaks. Refer to [CO-10, "System Inspection"](#).
- Start and warm up engine. Visually check for coolant and A/T fluid (if equipped) leaks. Repair as necessary.
- Check and adjust engine coolant level and A/T fluid (if equipped). Refer to [MA-13, "Fluids and Lubricants"](#).

Removal and Installation (Motor driven type)

INFOID:000000006255447

REMOVAL

NOTE:

When removing components such as hoses, tubes/lines, etc., cap or plug openings to prevent fluid from spilling.

1. Remove the engine under cover. Refer to [EXT-15, "Removal and Installation"](#).
2. Partially drain engine coolant from radiator. Refer to [CO-12, "Changing Engine Coolant"](#).

CAUTION:

- Perform this step when engine is cold.
 - Do not spill engine coolant on drive belts.
3. Release the radiator shroud (lower) (2) from the radiator shroud (upper) (1) and position aside.
 - Release the tabs, pull radiator shroud (lower) (2) rearward and down.

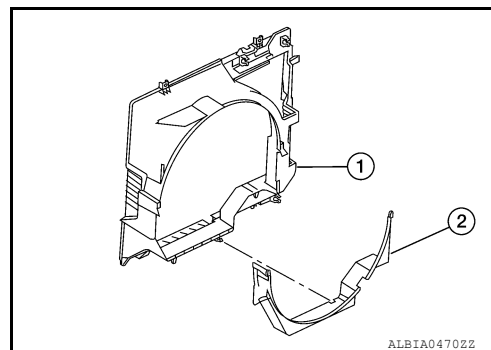

4. Remove air duct and resonator assembly. Refer to [EM-24, "Removal and Installation"](#).
5. Remove upper radiator hose from radiator.
6. Remove reservoir tank hose from radiator shroud (upper) and radiator.
7. Remove the radiator shroud (upper) bolts and remove the radiator shroud (upper). Refer to [CO-16, "Exploded View"](#).

ENGINE COOLING FAN

[VQ40DE]

< REMOVAL AND INSTALLATION >

8. Disconnect harness connector from fan motor.
9. Remove the bolt and remove the fan grille and motor assembly.

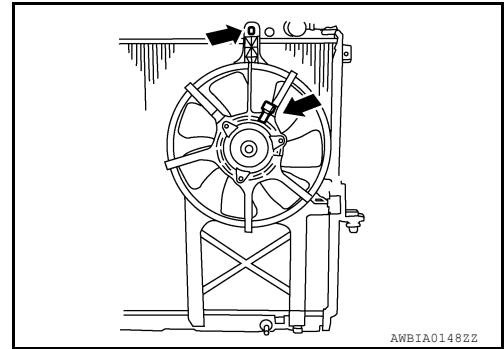

INSTALLATION

Installation is in the reverse order of removal.

- Cooling fan is controlled by ECM. For details, refer to [EC-369, "Diagnosis Procedure"](#).

INSPECTION AFTER INSTALLATION

- Check for engine coolant leaks. Refer to [CO-10, "System Inspection"](#).
- Start and warm up engine. Visually check for coolant and A/T fluid (if equipped) leaks. Repair as necessary.
- Check and adjust engine coolant level and A/T fluid (if equipped). Refer to [MA-13, "Fluids and Lubricants"](#).

A
CO
C
D
E
F
G
H
I
J
K
L
M
N
O
P

WATER PUMP

< REMOVAL AND INSTALLATION >

[VQ40DE]

WATER PUMP

Exploded View

INFOID:000000006255448

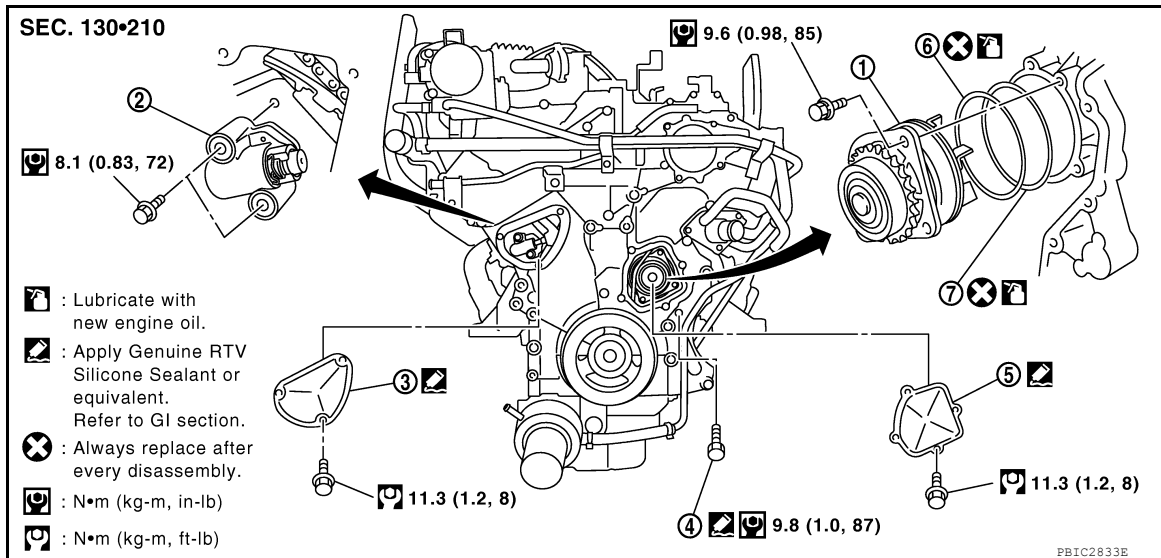

- | | | |
|-----------------------------|-------------------------------------|--------------------------|
| 1. Water pump | 2. Timing chain tensioner (primary) | 3. Chain tensioner cover |
| 4. Water drain plug (front) | 5. Water pump cover | 6. O-ring |
| 7. O-ring | | |

Removal and Installation

INFOID:000000006835291

WARNING:

Never remove the radiator cap when the engine is hot. Serious burns could occur from high pressure engine coolant escaping from the radiator. Wrap a thick cloth around the cap. Slowly turn it a quarter of a turn to release built-up pressure. Carefully remove radiator cap by turning it all the way.

CAUTION:

- When removing water pump assembly, be careful not to get engine coolant on timing chain and drive belt.
- Water pump cannot be disassembled and should be replaced as a unit.
- After installing water pump, connect hoses and clamps securely, then check for leaks.

NOTE:

When removing components such as hoses, tubes/lines, etc., cap or plug openings to prevent fluid from spilling.

REMOVAL

1. Remove engine under cover. Refer to [EXT-15. "Removal and Installation"](#).
2. Drain engine coolant from radiator. Refer to [CO-12. "Changing Engine Coolant"](#).
CAUTION:
 - Perform this step when engine is cold.
 - Do not spill engine coolant on timing chain and drive belt.
3. Remove air duct and resonator assembly. Refer to [EM-24. "Exploded View"](#).
4. Remove drive belt. Refer to [EM-13. "Removal and Installation"](#).
5. Remove radiator hose (upper).
6. Remove coolant reservoir hose from the radiator.
7. Remove engine cooling fan (Motor driven type). Refer to [CO-20. "Removal and Installation \(Motor driven type\)"](#).
8. Set No. 1 cylinder at TDC.

WATER PUMP

[VQ40DE]

< REMOVAL AND INSTALLATION >

- Rotate crankshaft pulley clockwise to align timing mark (A) (grooved line without color) with timing indicator (B).

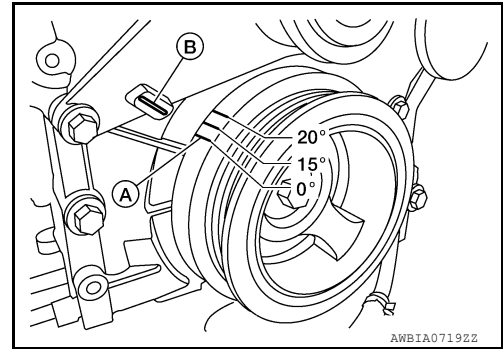

- Remove engine cooling fan (Crankshaft driven type). Refer to [CO-19. "Removal and Installation \(Crankshaft driven type\)"](#).
- Remove water drain plug (front) (1).

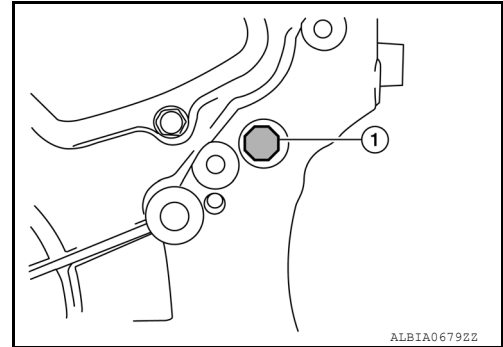

- Remove chain tensioner cover and water pump cover from front timing chain case, using Tool.

Tool number : KV10111100 (J-37228)

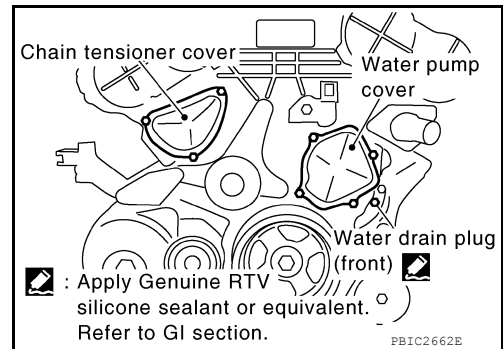

- Remove timing chain tensioner (primary) as follows:
 - Loosen clip of timing chain tensioner (primary), and release plunger stopper (1).
 - Depress plunger into tensioner body by pressing slack guide (2).
 - Keep slack guide pressed and insert stopper pin through the tensioner body hole and plunger groove (3) to hold plunger in.

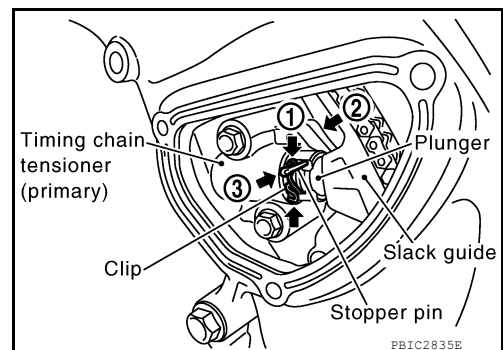

WATER PUMP

[VQ40DE]

< REMOVAL AND INSTALLATION >

- d. Remove timing chain tensioner bolts and remove timing chain tensioner (primary).

CAUTION:

Be careful not to drop timing chain tensioner bolts inside timing chain case.

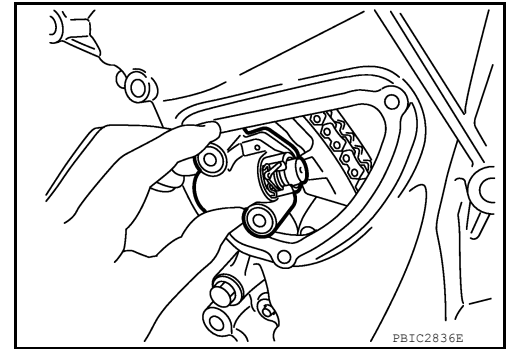

13. Remove water pump as follows:

- a. Make a gap between water pump sprocket and timing chain, by carefully turning crankshaft pulley counterclockwise until timing chain loosens on water pump sprocket. Remove three water pump bolts.

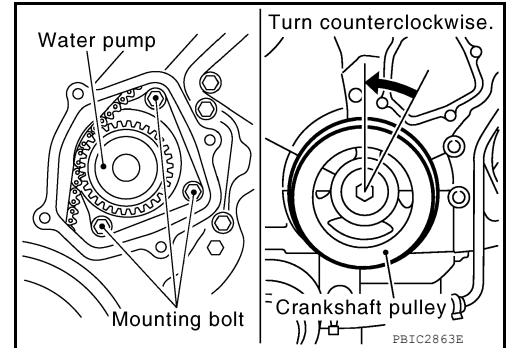

- b. Screw M8 bolts [pitch: 1.25 mm (0.049 in) length: approx. 50 mm (1.97 in)] into water pump upper and lower bolt holes until they reach timing chain case. Remove water pump.

CAUTION:

- Place a suitable shop cloth below the water pump housing to prevent any engine coolant from dripping into the timing chain case.
- Pull water pump straight out while preventing vane from contacting socket in installation area.
- Remove water pump without causing sprocket to contact timing chain.

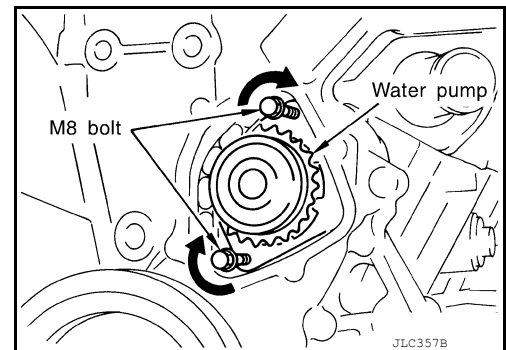

- c. Remove M8 bolts and O-rings from water pump.

CAUTION:

- Do not disassemble water pump.
- Do not reuse O-rings.

INSPECTION AFTER REMOVAL

- Visually check that there is no significant dirt or rusting on the water pump body and vane.
- Check that there is no looseness in the vane shaft, and that it turns smoothly when rotated by hand.
- If the water pump does not perform properly, replace the water pump assembly.

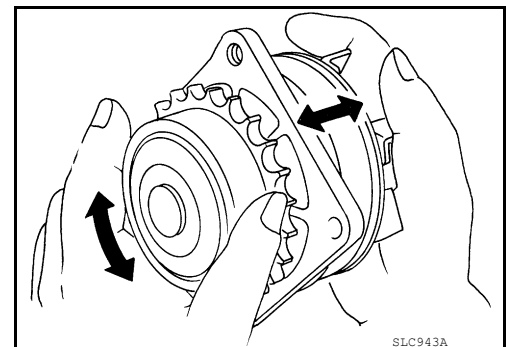

INSTALLATION

1. Install new O-rings to water pump.

CAUTION:

Do not reuse O-rings.

NOTE:

WATER PUMP

[VQ40DE]

< REMOVAL AND INSTALLATION >

- Apply engine oil to O-rings.
- Locate O-ring with white paint mark to engine front side.

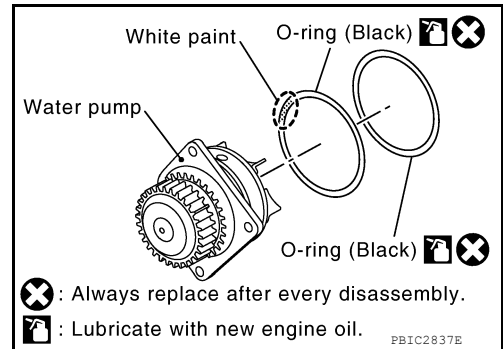

2. Hold timing chain to the side (←) and install water pump (←).

CAUTION:

Do not allow timing chain case to pinch O-rings when installing water pump.

- Make sure that timing chain and water pump sprocket are engaged.
- Tighten water pump bolts alternately and evenly.

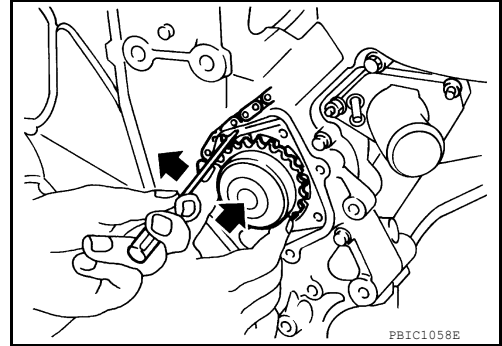

3. Remove dust and foreign material completely from installation area of timing chain tensioner (primary) and rear timing chain case.
4. Turn crankshaft pulley approximately 20° clockwise so that timing chain on the timing chain tensioner (primary) side is loose.

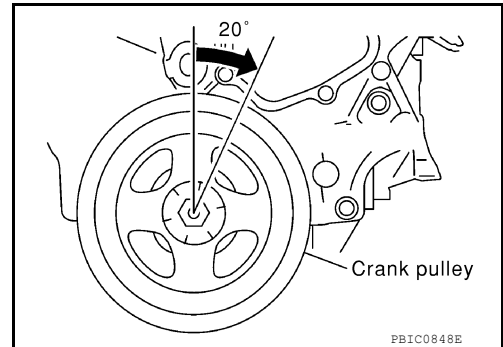

5. Install timing chain tensioner (primary) with its stopper pin inserted.

CAUTION:

Be careful not to drop bolts inside timing chain case.

6. Remove stopper pin.
- Make sure again that timing chain and water pump sprocket are engaged.

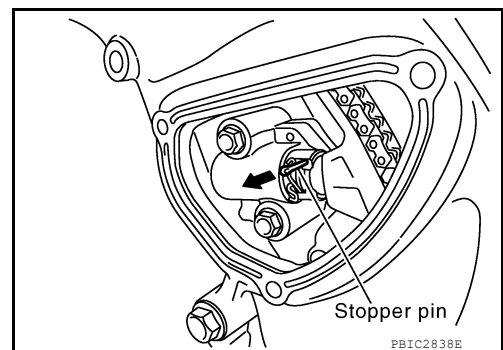

7. Install chain tensioner cover and water pump cover.

WATER PUMP

[VQ40DE]

< REMOVAL AND INSTALLATION >

- a. Before installing, remove all traces of old liquid gasket from mating surface of water pump cover and chain tensioner cover using scraper. Also remove traces of old liquid gasket from the mating surface of front timing chain case.

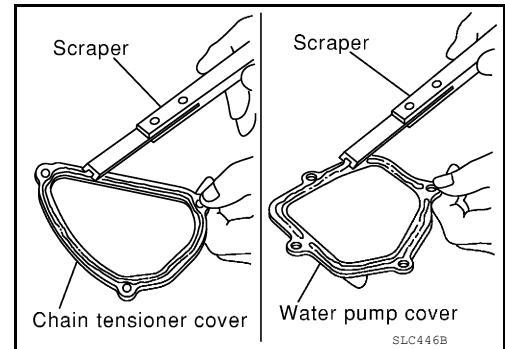

- b. Apply a continuous bead of liquid gasket, to mating surface of chain tensioner and water pump cover, using Tool.

Tool number : WS39930000 (—)

Use Genuine RTV Silicone Sealant or equivalent. Refer to [GI-15, "Recommended Chemical Products and Sealants"](#).

CAUTION:

Attaching should be done within 5 minutes after coating.

- c. Tighten bolts to specified torque. Refer to [CO-22, "Exploded View"](#).

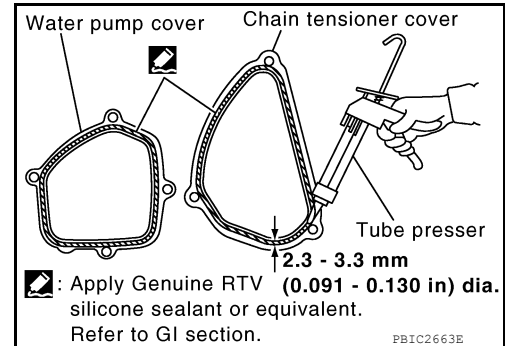

8. Install water drain plug (front) (1) on water pump side of cylinder block.

- Apply liquid gasket to the thread of water drain plug (front) (1). **Use Genuine RTV Silicone Sealant or equivalent. Refer to [GI-15, "Recommended Chemical Products and Sealants"](#).**

Water drain plug (front) : 9.8 N·m (1.0 kg·m, 87 in·lb)

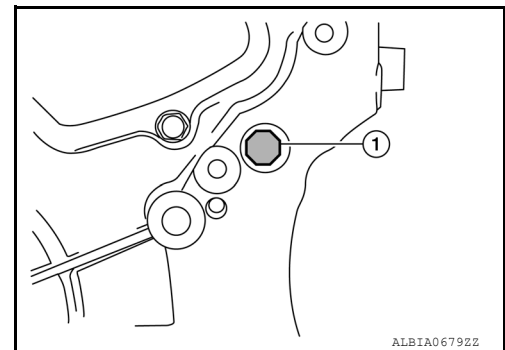

9. Installation of the remaining components is in the reverse order of removal.

- After installation refill engine coolant and check for leaks. Refer to [CO-12, "Changing Engine Coolant"](#) and [CO-10, "System Inspection"](#).

CAUTION:

Do not spill coolant in the engine compartment. Use a shop cloth to absorb coolant.

- After starting engine, let idle for three minutes, then rev engine up to 3,000 rpm under no load to purge air from the high-pressure chamber of the chain tensioner. The engine may produce a rattling noise. This indicates that air still remains in the chamber and is not a matter of concern.

INSPECTION AFTER INSTALLATION

- Check for engine coolant leaks. Refer to [CO-10, "System Inspection"](#).
- Start and warm up engine. Visually check for coolant leaks. Repair as necessary.
- Check and adjust engine coolant level. Refer to [MA-13, "Fluids and Lubricants"](#).

WATER INLET AND THERMOSTAT ASSEMBLY

< REMOVAL AND INSTALLATION >

[VQ40DE]

WATER INLET AND THERMOSTAT ASSEMBLY

Exploded View

INFOID:000000006255450

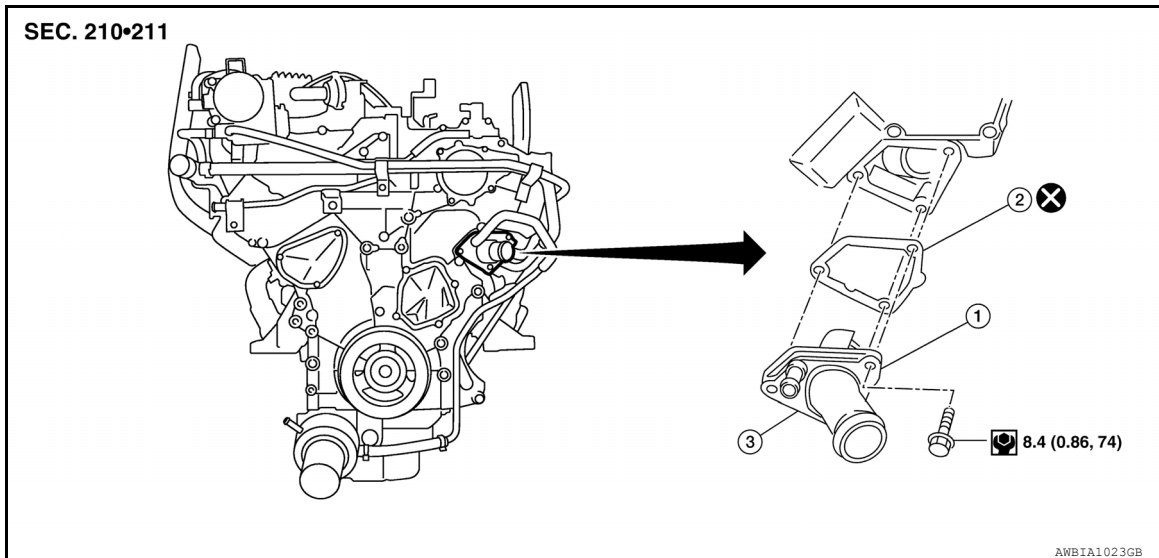

1. Water inlet and thermostat assembly 2. Gasket 3. To oil cooler

Removal and Installation

INFOID:000000006255451

WARNING:

Never remove the radiator cap when the engine is hot. Serious burns could occur from high pressure engine coolant escaping from the radiator. Wrap a thick cloth around the cap. Slowly turn it a quarter of a turn to release built-up pressure. Carefully remove radiator cap by turning it all the way.

NOTE:

When removing components such as hoses, tubes/lines, etc., cap or plug openings to prevent fluid from spilling.

REMOVAL

1. Remove engine cooling fan (Motor driven type). Refer to [CO-20. "Removal and Installation \(Motor driven type\)"](#).
2. Disconnect radiator hose (lower) and oil cooler hose from water inlet and thermostat assembly.
3. Remove water inlet and thermostat assembly.

CAUTION:

- Do not disassemble water inlet and thermostat assembly.
- Replace water inlet and thermostat assembly as a unit, if necessary.

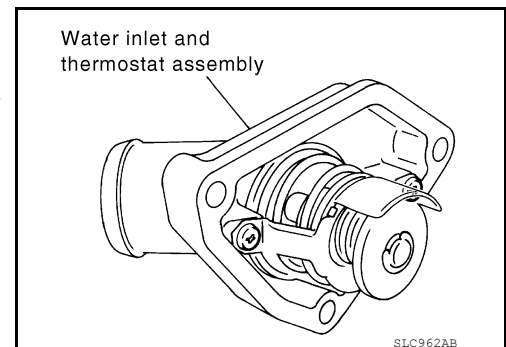

INSPECTION AFTER REMOVAL

1. Check valve seating condition at ordinary room temperatures. It should seat tightly.

WATER INLET AND THERMOSTAT ASSEMBLY

[VQ40DE]

< REMOVAL AND INSTALLATION >

2. Check valve operation.
 - Place a thread so that it is caught in the valve of the thermostat. Immerse fully in a container filled with water. Heat while stirring.
 - The valve opening temperature is the temperature at which the valve opens and falls from the thread.
 - Continue heating. Check the full-open lift amount.
 - After checking the full-open lift amount, lower the water temperature and check the valve closing temperature.

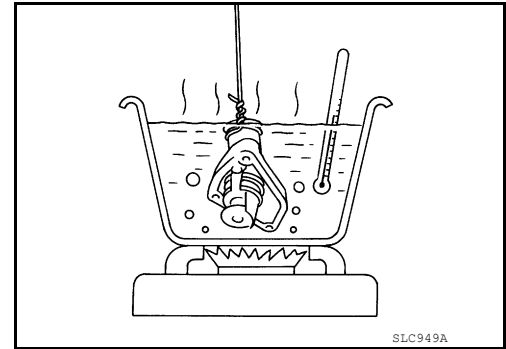

Thermostat	Standard
Valve opening temperature	Refer to CO-31, "Standard and Limit"
Full-open lift amount	Refer to CO-31, "Standard and Limit"
Valve closing temperature	Refer to CO-31, "Standard and Limit"

- If valve seating at measured values are out of standard range, replace water inlet and thermostat assembly.

INSTALLATION

Installation is in the reverse order of removal, paying attention to the following.

- **Do not spill engine coolant in engine room. Use rag to absorb engine coolant.**

INSPECTION AFTER INSTALLATION

- Check for engine coolant leaks. Refer to [CO-10, "System Inspection"](#).
- Start and warm up engine. Visually check for coolant leaks. Repair as necessary.
- Check and adjust engine coolant level. Refer to [MA-13, "Fluids and Lubricants"](#).

WATER OUTLET AND WATER PIPING

< REMOVAL AND INSTALLATION >

[VQ40DE]

WATER OUTLET AND WATER PIPING

Exploded View

INFOID:000000006255452

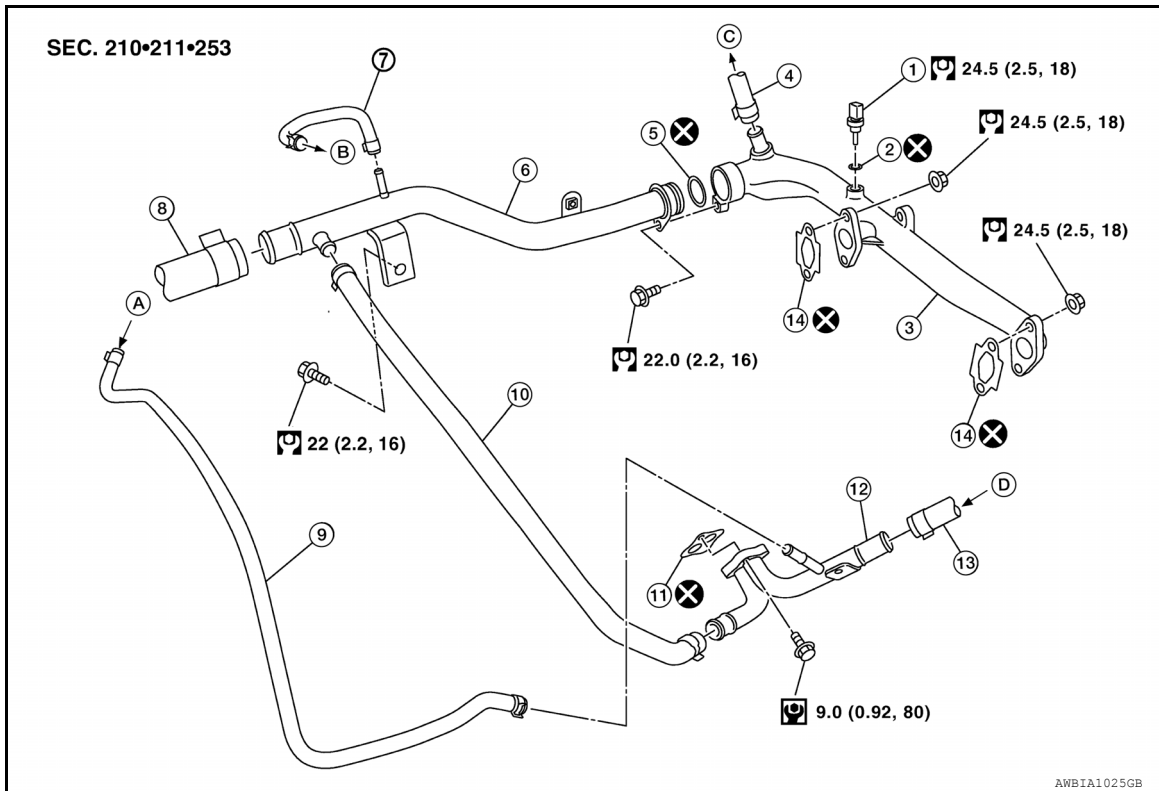

- | | | |
|--------------------------------------|--------------------------|-----------------|
| 1. Engine coolant temperature sensor | 2. Washer | 3. Water outlet |
| 4. Heater hose | 5. O-ring | 6. Water pipe |
| 7. Water hose | 8. Radiator hose (upper) | 9. Water hose |
| 10. Water hose | 11. Gasket | 12. Heater pipe |
| 13. Heater hose | 14. Gasket | |
- A. From electric throttle control actuator
B. To electric throttle control actuator
C. To heater
D. From heater

Removal and Installation

INFOID:000000006255453

WARNING:

Never remove the radiator cap when the engine is hot. Serious burns could occur from high pressure engine coolant escaping from the radiator. Wrap a thick cloth around the cap. Slowly turn it a quarter of a turn to release built-up pressure. Carefully remove radiator cap by turning it all the way.

NOTE:

When removing components such as hoses, tubes/lines, etc., cap or plug openings to prevent fluid from spilling.

REMOVAL

1. Drain engine coolant from radiator. Refer to [CO-12, "Changing Engine Coolant"](#).
CAUTION:
 - Perform this step when engine is cold.
 - Do not spill engine coolant on drive belts.
2. Remove the intake manifold collector. Refer to [EM-25, "Removal and Installation"](#).
3. Remove engine coolant temperature sensor as necessary.
CAUTION:
Be careful not to damage engine coolant temperature sensor.
4. Remove water outlet and gaskets, heater pipe, water bypass hoses and water pipe.

WATER OUTLET AND WATER PIPING

< REMOVAL AND INSTALLATION >

[VQ40DE]

INSTALLATION

Installation is in the reverse order of removal, paying attention to the following.

- Securely insert each hose, and install clamp at a position where it does not interfere with the pipe bulge.
- When inserting water pipe into water outlet, apply mild soap to O-ring.

CAUTION:

Do not reuse O-ring.

INSPECTION AFTER INSTALLATION

- Check for engine coolant leaks. Refer to [CO-10, "System Inspection"](#).
- Start and warm up engine. Visually check for coolant leaks. Repair as necessary.
- Check and adjust engine coolant level. Refer to [MA-13, "Fluids and Lubricants"](#).

SERVICE DATA AND SPECIFICATIONS (SDS)

< SERVICE DATA AND SPECIFICATIONS (SDS)

[VQ40DE]

SERVICE DATA AND SPECIFICATIONS (SDS)

SERVICE DATA AND SPECIFICATIONS (SDS)

Standard and Limit

INFOID:000000006255454

A

CO

ENGINE COOLANT CAPACITY (APPROXIMATE)

Unit: ℓ (US qt, Imp qt)

Engine coolant capacity (With reservoir tank at "MAX" level)	10.2 (10-3/4, 9)
--	------------------

C

RADIATOR

Unit: kPa (kg/cm², psi)

Reservoir cap relief pressure	Standard	98 - 118 (1.0 - 1.2, 14 - 17)
Leakage testing pressure		137 (1.4, 20)

D

E

THERMOSTAT

Valve opening temperature	80.5 - 83.5°C (177 - 182°F)
Full-open lift amount	8.6 mm / 95°C (0.339 in / 203°F)
Valve closing temperature	77°C (171°F)

F

G

H

I

J

K

L

M

N

O

P