

# SECTION PCS

## POWER CONTROL SYSTEM

A  
B  
C  
D  
E  
F  
G  
H  
I  
J  
K  
L  
N  
O  
P

### CONTENTS

|  |    |   |    |
|--|----|---|----|
| <b>IPDM E/R</b>                          |    | <b>POWER SUPPLY AND GROUND CIRCUIT</b> ....15 |    |
| <b>SYSTEM DESCRIPTION</b> .....          | 2  | Diagnosis Procedure .....                     | 15 |
| <b>RELAY CONTROL SYSTEM</b> .....        | 2  | <b>ECU DIAGNOSIS INFORMATION</b> .....        | 16 |
| System Diagram .....                     | 2  | <b>IPDM E/R (INTELLIGENT POWER DISTRI-</b>    |    |
| System Description .....                 | 3  | <b>BUTION MODULE ENGINE ROOM)</b> .....       | 16 |
| Component Parts Location .....           | 4  | Reference Value .....                         | 16 |
| <b>POWER DISTRIBUTION SYSTEM</b> .....   | 5  | Terminal Layout .....                         | 17 |
| System Description .....                 | 5  | Physical Values .....                         | 18 |
| Component Parts Location .....           | 5  | Fail Safe .....                               | 21 |
| Component Description .....              | 5  | DTC Index .....                               | 22 |
| <b>POWER CONTROL SYSTEM</b> .....        | 6  | <b>WIRING DIAGRAM</b> .....                   | 23 |
| System Diagram .....                     | 6  | <b>IPDM E/R (INTELLIGENT POWER DISTRI-</b>    |    |
| System Description .....                 | 6  | <b>BUTION MODULE ENGINE ROOM)</b> .....       | 23 |
| <b>SIGNAL BUFFER SYSTEM</b> .....        | 7  | Wiring Diagram .....                          | 23 |
| System Diagram .....                     | 7  | <b>PRECAUTION</b> .....                       | 27 |
| System Description .....                 | 7  | <b>PRECAUTIONS</b> .....                      | 27 |
| <b>POWER CONSUMPTION CONTROL SYS-</b>    |    | Precaution for Supplemental Restraint System  |    |
| <b>TEM</b> .....                         | 8  | (SRS) "AIR BAG" and "SEAT BELT PRE-TEN-       |    |
| System Diagram .....                     | 8  | SIONER" .....                                 | 27 |
| System Description .....                 | 8  | <b>REMOVAL AND INSTALLATION</b> .....         | 28 |
| Component Parts Location .....           | 9  | <b>BCM (BODY CONTROL MODULE)</b> .....        | 28 |
| <b>DIAGNOSIS SYSTEM (IPDM E/R)</b> ..... | 10 | Removal and Installation .....                | 28 |
| Diagnosis Description .....              | 10 | <b>UNIT REMOVAL AND INSTALLATION</b> .....    | 29 |
| CONSULT - III Function (IPDM E/R) .....  | 12 | <b>IPDM E/R (INTELLIGENT POWER DISTRI-</b>    |    |
| <b>DTC/CIRCUIT DIAGNOSIS</b> .....       | 14 | <b>BUTION MODULE ENGINE ROOM)</b> .....       | 29 |
| <b>U1000 CAN COMM CIRCUIT</b> .....      | 14 | Removal and Installation of IPDM E/R .....    | 29 |
| Description .....                        | 14 |   |    |
| DTC Logic .....                          | 14 |   |    |
| Diagnosis Procedure .....                | 14 |   |    |

PCS

# RELAY CONTROL SYSTEM

< SYSTEM DESCRIPTION >

[IPDM E/R]

## SYSTEM DESCRIPTION

### RELAY CONTROL SYSTEM

#### System Diagram

INFOID:000000006253967

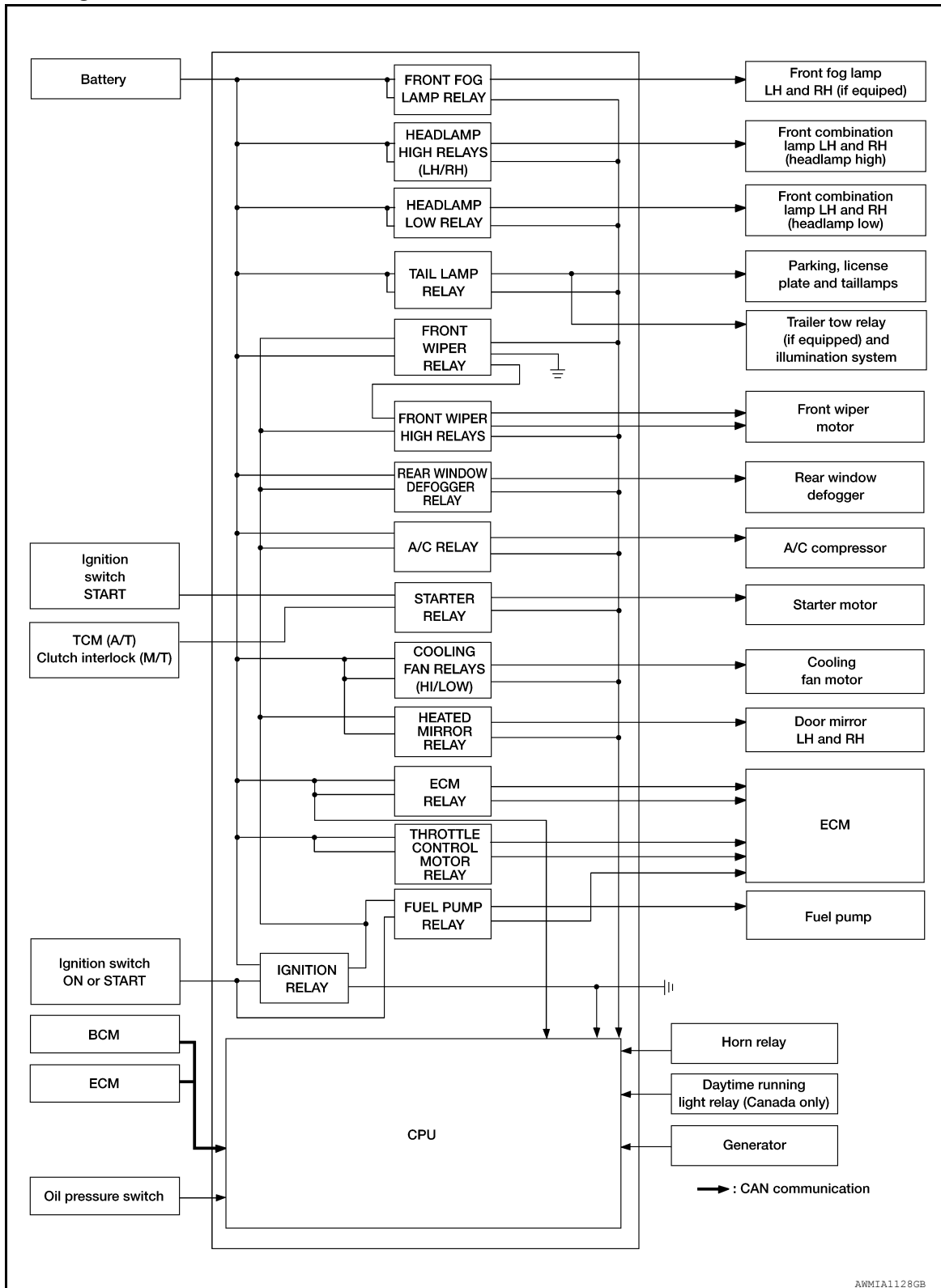

ANMIA1128GB

# RELAY CONTROL SYSTEM

< SYSTEM DESCRIPTION >

[IPDM E/R]

## System Description

INFOID:000000006253968

IPDM E/R activates the internal control circuit to perform the relay ON-OFF control according to the input signals from various sensors and the request signals received from control units via CAN communication.

**CAUTION:**

**IPDM E/R integrated relays cannot be removed.**

| Control relay  | Input/output  | Transmit unit          | Control part   | Reference page  |
|--|---|------------------------|--|---|
| Front fog lamp relay<br>(if equipped)  | Front fog lamp request signal   | BCM (CAN)              | Front fog lamps<br>(if equipped)   | <a href="#">EXL-51</a>  |
| <ul style="list-style-type: none"> <li>• Headlamp (LH) high relay</li> <li>• Headlamp (RH) high relay</li> <li>• Headlamp low relay</li> </ul> | <ul style="list-style-type: none"> <li>• High beam request signal</li> <li>• Low beam request signal</li> </ul> | BCM (CAN)              | <ul style="list-style-type: none"> <li>• Headlamp high</li> <li>• Headlamp low</li> </ul>  | <a href="#">EXL-37</a><br><a href="#">EXL-40</a>  |
| Tail lamp relay  | Position light request signal   | BCM (CAN)              | <ul style="list-style-type: none"> <li>• Parking lamps</li> <li>• License plate lamps</li> <li>• Tail lamps</li> <li>• Trailer tow relay<br/>(if equipped)</li> <li>• Illumination system</li> </ul> | <a href="#">EXL-56</a>  |
| <ul style="list-style-type: none"> <li>• Front wiper relay</li> <li>• Front wiper high relay</li> </ul>  | Front wiper request signal  | BCM (CAN)              | Front wiper motor  | <a href="#">WW-4</a>  |
| Rear window defogger relay   | Rear window defogger request signal   | BCM (CAN)              | Rear window defogger   | <a href="#">DEF-5</a>   |
| A/C relay  | A/C request signal  | BCM (CAN)<br>ECM (CAN) | A/C compressor   | <a href="#">HAC-37</a><br>(Manual A/C type<br>1)<br><a href="#">HAC-106</a><br>(Manual A/C type<br>2) |
| Starter relay  | Ignition switch START signal  | TCM                    | Starter motor  | <a href="#">STR-9</a>   |
| Cooling fan relays   | Cooling fan request signal  | ECM (CAN)              | Cooling fan relay  | <a href="#">CO-7</a>  |
| Heated mirror relay  | Heated mirror request signal  | BCM (CAN)              | Door mirrors   | <a href="#">DEF-15</a>  |
| ECM relay  | ECM relay control signal  | ECM (CAN)              | ECM relay  | <a href="#">EC-140</a>  |
| Throttle control motor relay   | Throttle control motor control signal   | ECM (CAN)              | Throttle control motor relay   | <a href="#">EC-419</a>  |
| Fuel pump relay  | Fuel pump request signal  | ECM (CAN)              | Fuel pump  | <a href="#">EC-460</a>  |
| Ignition relay   | Ignition switch ON signal   | Ignition switch        | Ignition relay   | <a href="#">BCS-5</a>   |

A  
B  
C  
D  
E  
F  
G  
H  
I  
J  
K  
L

PCS

N  
O  
P

# RELAY CONTROL SYSTEM

< SYSTEM DESCRIPTION >

[IPDM E/R]

## Component Parts Location

INFOID:00000006253969

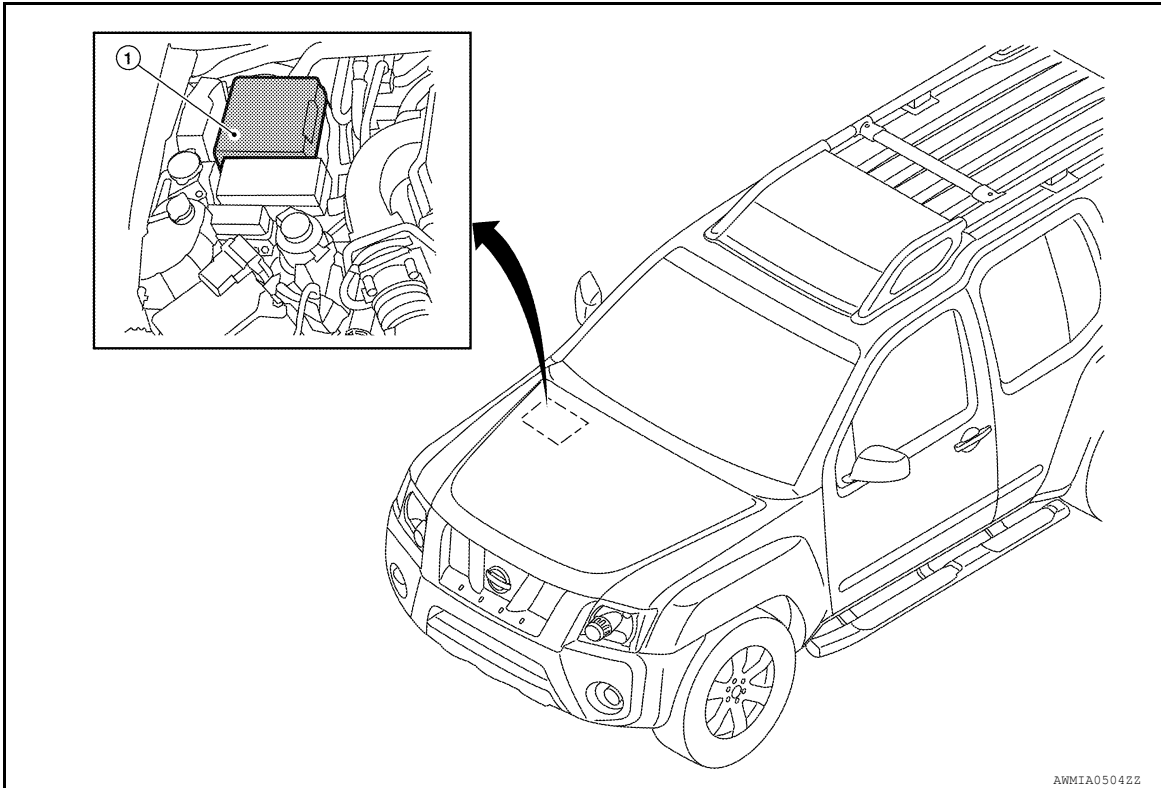

1. IPDM E/R E118, E119, E120, E121, E122, E123, E124

# POWER DISTRIBUTION SYSTEM

< SYSTEM DESCRIPTION >

[IPDM E/R]

## POWER DISTRIBUTION SYSTEM

### System Description

INFOID:000000006253970

### INPUT/OUTPUT SIGNAL CHART

| Switch                    | Input Signal to BCM | BCM system                | Actuator   |
|---------------------------|---------------------|---------------------------|--|
| Ignition switch           | Ignition switch     | Power distribution system | <ul style="list-style-type: none"> <li>Ignition relay (IPDM E/R)</li> <li>ACC relay</li> <li>Blower relay</li> </ul> |
| A/T shift selector        | P range             |                           |  |
| transmission range switch | N, P range          |                           |  |

### SYSTEM DESCRIPTION

- PDS (POWER DISTRIBUTION SYSTEM) is the system that BCM controls with the operation of the ignition switch and performs the power distribution to each power circuit.
- The ignition switch operation is input to BCM as a signal. BCM changes the power supply position according to the status and operates the ignition relay (inside IPDM E/R) to supply power to each power circuit.

### Component Parts Location

INFOID:000000006253971

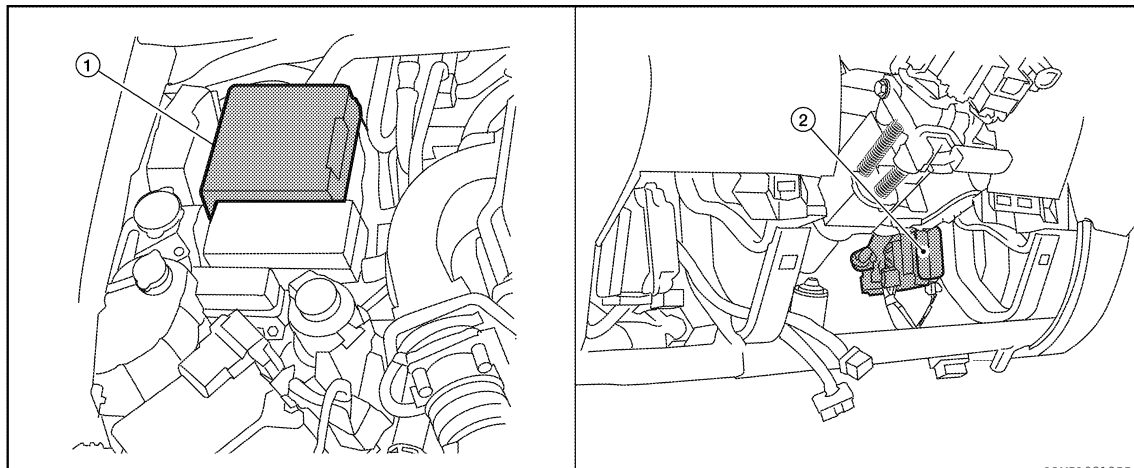

- IPDM E/R (contains ignition relay) E118, E119, E120, E121, E122, E123, E124
- BCM (view with lower instrument panel LH removed) M18, M19, M20

### Component Description

INFOID:000000006253972

| BCM                          | Reference              |
|------------------------------|------------------------|
| IPDM E/R                     | <a href="#">PCS-3</a>  |
| Ignition relay (in IPDM E/R) | <a href="#">PCS-3</a>  |
| Transmission range switch    | <a href="#">TM-230</a> |

PCS

## POWER CONTROL SYSTEM

### System Diagram

INFOID:000000006253973

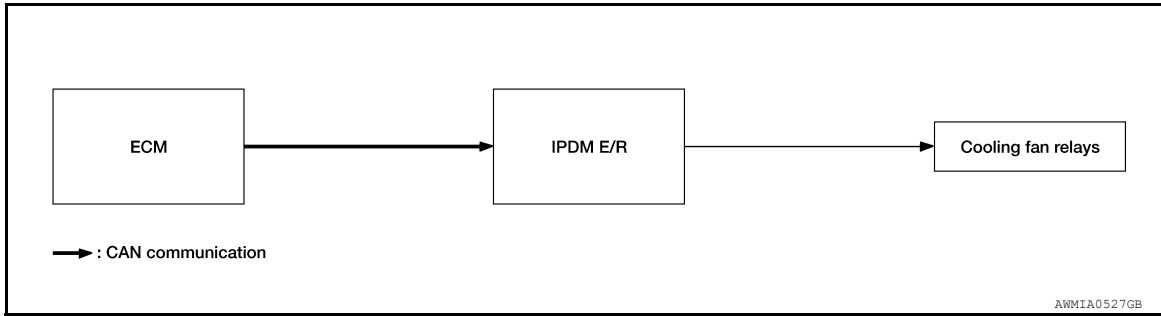

### System Description

INFOID:000000006253974

#### COOLING FAN CONTROL

IPDM E/R controls the cooling fan according to the status of the cooling fan speed request signal received from ECM via CAN communication. Refer to [EC-31, "Description"](#).

# SIGNAL BUFFER SYSTEM

< SYSTEM DESCRIPTION >

[IPDM E/R]

## SIGNAL BUFFER SYSTEM

### System Diagram

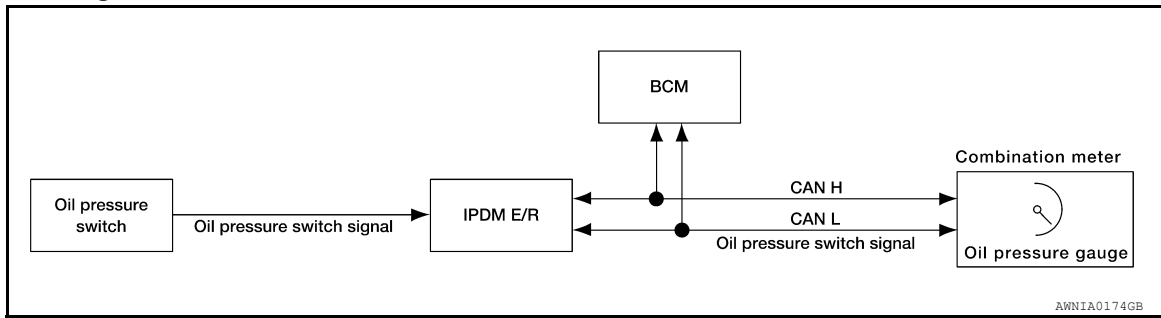

### System Description

INFOID:000000006253976

IPDM E/R reads the status of the oil pressure switch and transmits the oil pressure switch signal to BCM via CAN communication. Refer to [BCS-12. "System Description"](#).

A  
B  
C  
D  
E  
F  
G  
H  
I  
J  
K  
L

PCS

N  
O  
P

## POWER CONSUMPTION CONTROL SYSTEM

### System Diagram

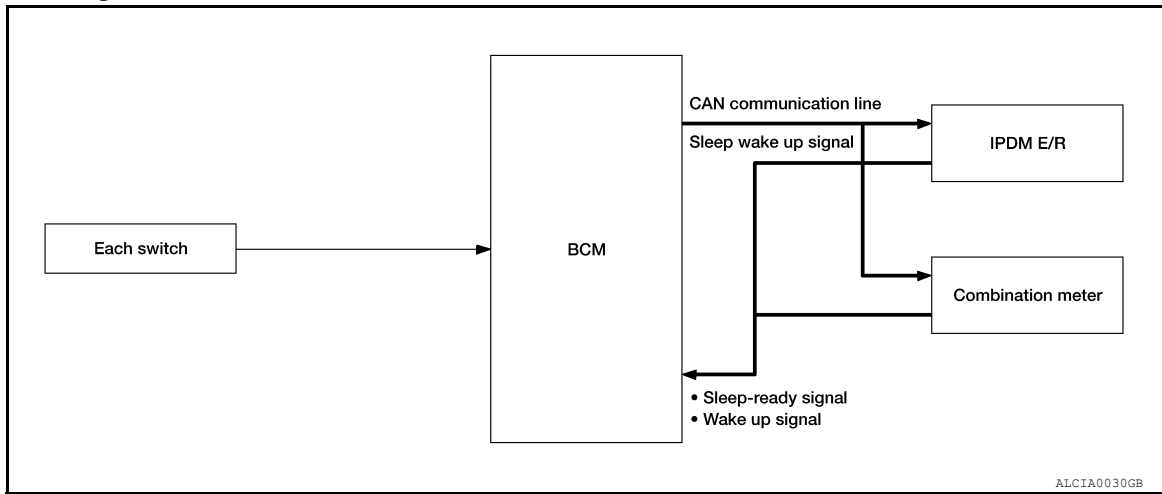

INFOID:000000006253977

### System Description

INFOID:000000006253978

#### OUTLINE

- IPDM E/R incorporates a power consumption control function that reduces the power consumption according to the vehicle status.
- IPDM E/R changes its status (control mode) with the sleep wake up signal received from BCM via CAN communication.

#### Normal mode (wake-up)

- CAN communication is normally performed with other control units.
- Individual unit control by IPDM E/R is normally performed.

#### Low power consumption mode (sleep)

- Low power consumption control is active.
- CAN transmission is stopped.

#### SLEEP MODE ACTIVATION

- IPDM E/R judges that the sleep-ready conditions are fulfilled when the ignition switch is OFF and none of the conditions below are present. Then it transmits a sleep-ready signal (ready) to BCM via CAN communication.
  - Front wiper fail-safe operation
  - Outputting signals to actuators
  - Switches or relays operating
  - Auto active test is starting
  - Emergency OFF
  - Output requests are being received from control units via CAN communication.
- IPDM E/R stops CAN communication and enters the low power consumption mode when it receives a sleep wake up signal (sleep) from BCM and the sleep-ready conditions are fulfilled.

#### WAKE-UP OPERATION

- IPDM E/R changes from the low power consumption mode to the normal mode when it receives a sleep wake-up signal (wake up) from BCM or any of the following conditions is fulfilled. In addition, it transmits a sleep-ready signal (not-ready) to BCM via CAN communication to report the CAN communication start.
  - Ignition switch ON
  - An output request is received from a control unit via CAN communication.



# POWER CONSUMPTION CONTROL SYSTEM

< SYSTEM DESCRIPTION >

[IPDM E/R]

## Component Parts Location

INFOID:00000006253979

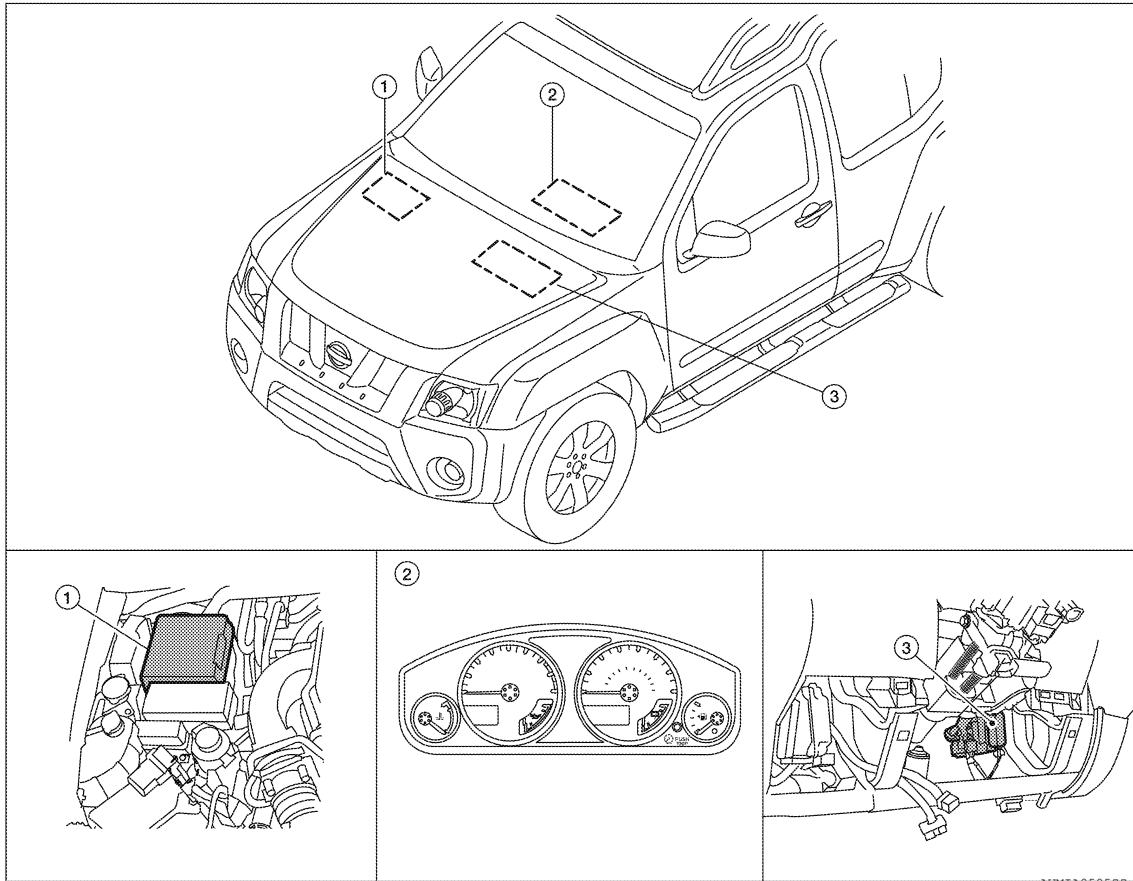

1. IPDM E/R E118, E119, E120, E121, E122, E123, E124

2. Combination meter M24

3. BCM (view with lower instrument panel LH removed) M18, M19, M20

A  
B  
C  
D  
E  
F  
G  
H  
I  
J  
K  
L  
N  
O  
P

PCS

## DIAGNOSIS SYSTEM (IPDM E/R)

### Diagnosis Description

INFOID:000000006253980

#### AUTO ACTIVE TEST

##### Description

In auto active test mode, the IPDM E/R sends a drive signal to the following systems to check their operation.

- Oil pressure low warning indicator
- Oil pressure gauge
- Rear window defogger
- Front wipers
- Tail, license and parking lamps
- Front fog lamps (if equipped)
- Headlamps (Hi, Lo)
- A/C compressor (magnetic clutch)
- Cooling fan

##### Operation Procedure

1. Close the hood and front door RH, and lift the wiper arms from the windshield (to prevent windshield damage due to wiper operation).  
**NOTE:**  
When auto active test is performed with hood opened, sprinkle water on windshield before hand.
2. Turn ignition switch OFF.
3. Turn the ignition switch ON and, within 20 seconds, press the front door switch LH 10 times. Then turn the ignition switch OFF.
4. Turn the ignition switch ON within 10 seconds. After that the horn sounds once and the auto active test starts.
5. After a series of the following operations is repeated 3 times, auto active test is completed.

##### **NOTE:**

When auto active test mode has to be cancelled halfway through test, turn ignition switch OFF.

##### **CAUTION:**

- **If auto active test mode cannot be actuated, check door switch system. Refer to [DLK-25, "Description"](#).**
- **Do not start the engine.**

##### Inspection in Auto Active Test Mode

When auto active test mode is actuated, the following 7 steps are repeated 3 times.

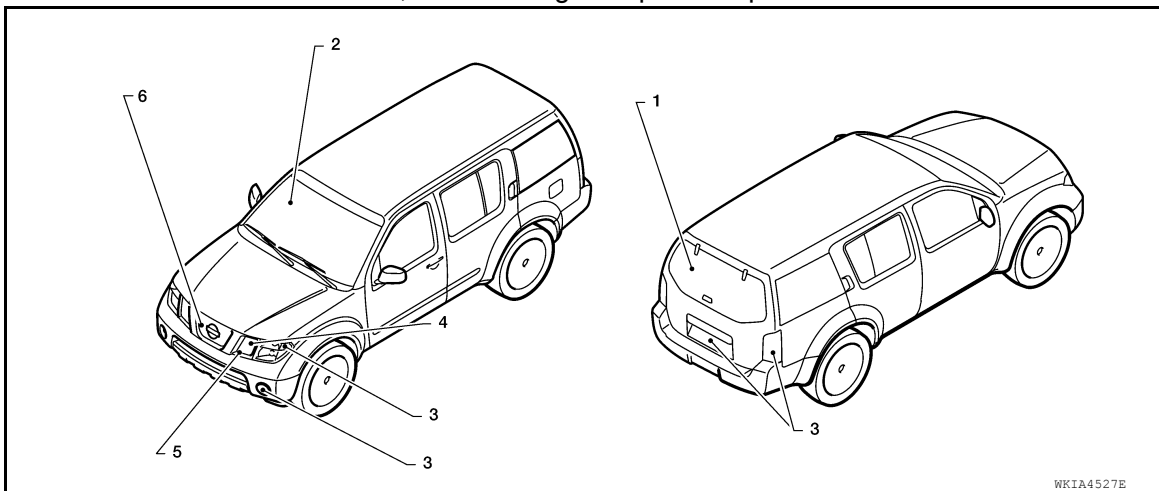

| Item Number | Test Item  | Operation Time/Frequency          |
|-------------|--|-----------------------------------|
| 1           | Rear window defogger                                     | 10 seconds                        |
| 2           | Front wipers   | LOW 5 seconds then HIGH 5 seconds |
| 3           | License plate, tail, parking and fog lamps (if equipped) | 10 seconds                        |

# DIAGNOSIS SYSTEM (IPDM E/R)

< SYSTEM DESCRIPTION >

[IPDM E/R]

| Item Number | Test Item                      | Operation Time/Frequency                |
|-------------|--------------------------------|---|
| 4           | Headlamps                      | LOW 10 seconds then HIGH ON-OFF 5 times |
| 5           | A/C compressor (magnet clutch) | ON-OFF 5 times                          |
| 6           | Cooling fan                    | LOW 5 seconds, then HIGH 5 seconds      |

Concept of auto active test

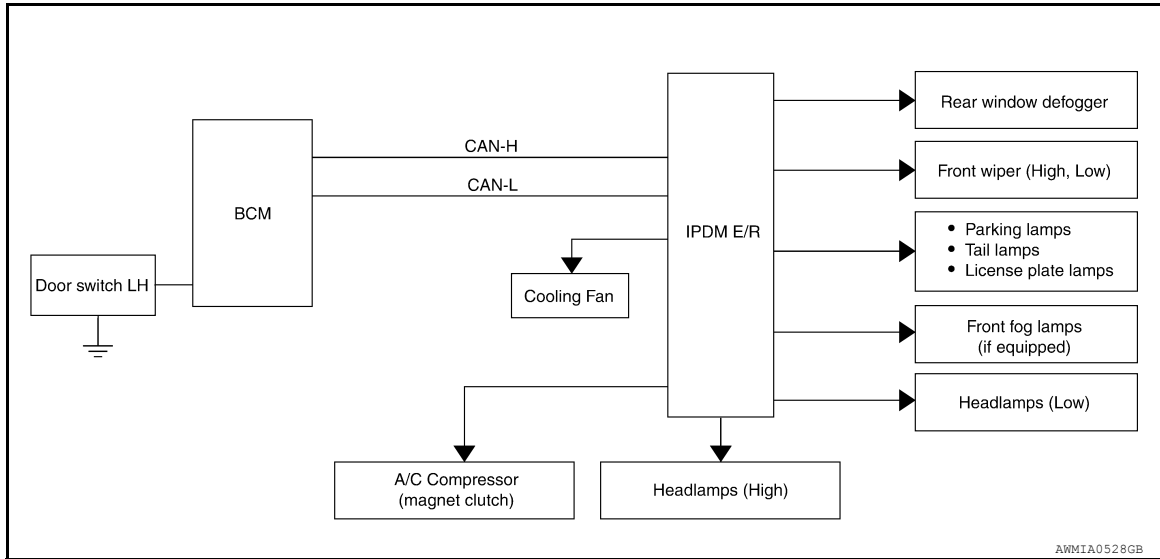

- IPDM E/R starts the auto active test with the door switch signals transmitted by BCM via CAN communication. Therefore, the CAN communication line between IPDM E/R and BCM is considered normal if the auto active test starts successfully.
- The auto active test facilitates troubleshooting if any systems controlled by IPDM E/R cannot be operated.

Diagnosis chart in auto active test mode

| Symptom   | Inspection contents   | Possible cause   |
|---|---|--|
| Oil pressure low warning indicator does not operate | Perform auto active test.<br>Does the oil pressure low warning indicator operate? | YES<br>• IPDM E/R signal input circuit<br>• ECM signal input circuit<br>• CAN communication signal between ECM and combination meter |
|   |   | NO<br>• CAN communication signal between IPDM E/R, BCM and combination meter   |
| Oil pressure gauge does not operate                 | Perform auto active test.<br>Does the oil pressure gauge operate?                 | YES<br>IPDM E/R signal input circuit   |
|   |   | NO<br>• CAN communication signal between IPDM E/R, BCM and combination meter   |
| Rear window defogger does not operate               | Perform auto active test.<br>Does the rear window defogger operate?               | YES<br>BCM signal input circuit  |
|   |   | NO<br>• Harness or connector between front air control and BCM<br>• CAN communication signal between BCM and IPDM E/R                |

# DIAGNOSIS SYSTEM (IPDM E/R)

< SYSTEM DESCRIPTION >

[IPDM E/R]

| Symptom  | Inspection contents  | Possible cause   |
|--|--|--|
| Any of the following components do not operate <ul style="list-style-type: none"> <li>• Front wipers</li> <li>• Tail lamps</li> <li>• License plate lamps</li> <li>• Parking lamps</li> <li>• Front fog lamps (if equipped)</li> <li>• Headlamps (Hi, Lo)</li> </ul> | Perform auto active test.<br>Does the applicable system operate? | YES<br>BCM signal input system   |
|  |  | NO <ul style="list-style-type: none"> <li>• Lamp or front wiper motor malfunction</li> <li>• Lamp or front wiper motor ground circuit</li> <li>• Harness or connector between IPDM E/R and applicable system</li> <li>• IPDM E/R (integrated relay malfunction)</li> </ul> |
| A/C compressor does not operate  | Perform auto active test.<br>Does the A/C compressor operate?    | YES <ul style="list-style-type: none"> <li>• BCM signal input circuit</li> <li>• CAN communication signal between BCM and ECM</li> <li>• CAN communication signal between ECM and IPDM E/R</li> </ul>  |
|  |  | NO <ul style="list-style-type: none"> <li>• Magnetic clutch malfunction</li> <li>• Harness or connector between IPDM E/R and magnetic clutch</li> <li>• IPDM E/R (integrated relay malfunction)</li> </ul>   |
| Cooling fan does not operate   | Perform auto active test.<br>Does the cooling fan operate?       | YES <ul style="list-style-type: none"> <li>• ECM signal input circuit</li> <li>• CAN communication signal between ECM and IPDM E/R</li> </ul>  |
|  |  | NO <ul style="list-style-type: none"> <li>• Cooling fan motor malfunction</li> <li>• Harness or connector between IPDM E/R and cooling fan</li> <li>• IPDM E/R (integrated relay malfunction)</li> </ul>   |

## CONSULT - III Function (IPDM E/R)

INFOID:000000006253981

### APPLICATION ITEM

CONSULT-III performs the following functions via CAN communication with IPDM E/R.

| Direct Diagnostic Mode | Description   |
|------------------------|---|
| Self Diagnostic Result | The IPDM E/R self diagnostic results are displayed.                         |
| Data Monitor           | The IPDM E/R input/output data is displayed in real time.                   |
| Active Test            | The IPDM E/R activates outputs to test components.                          |
| CAN Diag Support Mntr  | The result of transmit/receive diagnosis of CAN communication is displayed. |

### SELF DIAGNOSTIC RESULT

Refer to [PCS-22, "DTC Index"](#).

### DATA MONITOR

| Monitor Item [Unit]     | Main Signals | Description   |
|-------------------------|--------------|---|
| MOTOR FAN REQ [1/2/3/4] | ×            | Indicates cooling fan speed signal received from ECM on CAN communication line      |
| AC COMP REQ [On/Off]    | ×            | Indicates A/C compressor request signal received from ECM on CAN communication line |

# DIAGNOSIS SYSTEM (IPDM E/R)

< SYSTEM DESCRIPTION >

[IPDM E/R]

| Monitor Item [Unit]           | Main Signals | Description   |
|-------------------------------|--------------|---|
| TAIL&CLR REQ [On/Off]         | ×            | Indicates position light request signal received from BCM on CAN communication line     |
| HL LO REQ [On/Off]            | ×            | Indicates low beam request signal received from BCM on CAN communication line           |
| HL HI REQ [On/Off]            | ×            | Indicates high beam request signal received from BCM on CAN communication line          |
| FR FOG REQ [On/Off]           | ×            | Indicates front fog light request signal received from BCM on CAN communication line    |
| FR WIP REQ [Stop/1LOW/Low/Hi] | ×            | Indicates front wiper request signal received from BCM on CAN communication line        |
| WIP AUTO STOP [STOP P/ACT P]  | ×            | Indicates condition of front wiper auto stop signal                                     |
| WIP PROT [Off/BLOCK]          | ×            | Indicates condition of front wiper fail-safe operation                                  |
| ST RLY REQ [On/Off]           |              | Indicates starter request signal received from ECM on CAN communication line            |
| IGN RLY [On/Off]              | ×            | Indicates condition of ignition relay   |
| RR DEF REQ [On/Off]           | ×            | Indicates rear defogger request signal received from BCM on CAN communication line      |
| OIL P SW [Open/Close]         |              | Indicates condition of oil pressure switch  |
| DTRL REQ [Off]                |              | Indicates daytime light request signal received from BCM on CAN communication line      |
| THFT HRN REQ [On/Off]         |              | Indicates theft warning horn request signal received from BCM on CAN communication line |
| HORN CHIRP [On/Off]           |              | Indicates horn reminder signal received from BCM on CAN communication line              |

## ACTIVE TEST

| Test item      | Description  |
|----------------|--|
| REAR DEFOGGER  | This test is able to check rear defogger operation [On/Off].             |
| FRONT WIPER    | This test is able to check wiper motor operation [Hi/Lo/Off].            |
| MOTOR FAN      | This test is able to check cooling fan operation [4/3/2/1].              |
| EXTERNAL LAMPS | This test is able to check external lamp operation [Fog/Hi/Lo/TAIL/Off]. |
| HORN           | This test is able to check horn operation [On].                          |

A  
B  
C  
D  
E  
F  
G  
H  
I  
J  
K  
L

PCS

N  
O  
P

# U1000 CAN COMM CIRCUIT

< DTC/CIRCUIT DIAGNOSIS >

[IPDM E/R]

## DTC/CIRCUIT DIAGNOSIS

### U1000 CAN COMM CIRCUIT

#### Description

INFOID:000000006253982

Refer to [LAN-4, "System Description"](#).

#### DTC Logic

INFOID:000000006253983

#### DTC DETECTION LOGIC

| DTC   | CONSULT-III display description | DTC Detection Condition  | Possible cause  |
|-------|---------------------------------|--|---|
| U1000 | CAN COMM CIRCUIT                | When IPDM E/R cannot communicate CAN communication signal continuously for 2 seconds or more | In CAN communication system, any item (or items) of the following listed below is malfunctioning. <ul style="list-style-type: none"><li>• Receiving (TCM)</li><li>• Receiving (ECM)</li><li>• Receiving (BCM)</li><li>• Receiving (Combination meter)</li></ul> |

#### DTC CONFIRMATION PROCEDURE

#### Diagnosis Procedure

INFOID:000000006253984

#### 1. PERFORM SELF DIAGNOSTIC

1. Turn ignition switch ON and wait for 2 seconds or more.
2. Check "SELF-DIAG RESULTS" of IPDM E/R.

Is "CAN COMM CIRCUIT" displayed?

- YES >> Refer to [LAN-5, "CAN Communication Control Circuit"](#).  
NO >> Refer to [GI-37, "Intermittent Incident"](#).

# POWER SUPPLY AND GROUND CIRCUIT

< DTC/CIRCUIT DIAGNOSIS >

[IPDM E/R]

## POWER SUPPLY AND GROUND CIRCUIT

### Diagnosis Procedure

INFOID:000000006253985

Regarding Wiring Diagram information, refer to [PCS-23, "Wiring Diagram"](#).

### 1. CHECK FUSIBLE LINKS

Check that the following IPDM E/R fusible links are not blown.

| Terminal No. | Signal name | Fusible link No. |
|--------------|-------------|------------------|
| 1            | Battery     | A, D             |
| 2            |             | C                |
| 22           |             | I                |

Is the fusible link blown?

- YES >> Replace the blown fusible link after repairing the affected circuit.  
 NO >> GO TO 2

### 2. CHECK BATTERY POWER SUPPLY CIRCUIT

- Turn ignition switch OFF.
- Disconnect IPDM E/R.
- Check voltage between IPDM E/R harness connectors and ground.

| Terminals (+) |          | (-)    | Ignition switch position | Voltage (V) (Approx.) |
|---------------|----------|--------|--------------------------|-----------------------|
| Connector     | Terminal |        |                          |                       |
| E118 (A)      | 1        | Ground | OFF                      | Battery voltage       |
|               | 2        |        |                          |                       |
| E120 (B)      | 22       |        |                          |                       |

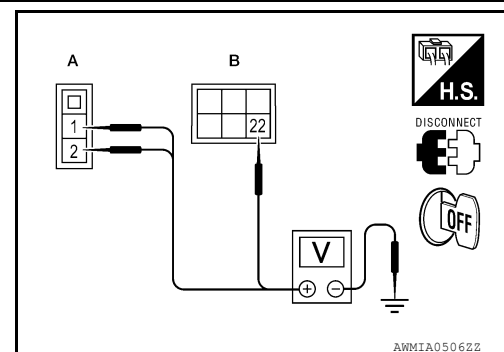

Is there voltage on all pins?

- YES >> GO TO 3  
 NO >> Repair or replace harness.

### 3. CHECK GROUND CIRCUIT

- Turn ignition switch OFF.
- Check continuity between IPDM E/R harness connectors and ground.

| IPDM E/R  |          | Ground | Continuity |
|-----------|----------|--------|------------|
| Connector | Terminal |        |            |
| E122 (A)  | 38       | Ground | Yes        |
| E124 (B)  | 59       |        |            |

Does continuity exist?

- YES >> Inspection End.  
 NO >> Repair or replace harness.

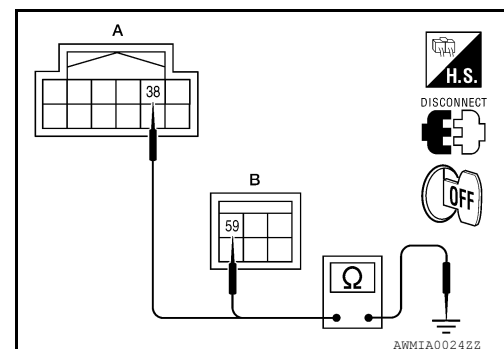

# IPDM E/R (INTELLIGENT POWER DISTRIBUTION MODULE ENGINE ROOM)

< ECU DIAGNOSIS INFORMATION >

[IPDM E/R]

## ECU DIAGNOSIS INFORMATION

### IPDM E/R (INTELLIGENT POWER DISTRIBUTION MODULE ENGINE ROOM)

Reference Value

INFOID:000000006253986

#### VALUES ON THE DIAGNOSIS TOOL

| Monitor Item  | Condition  |  | Value/Status |
|---------------|--|--|--------------|
| MOTOR FAN REQ | Engine idle speed  | Changes depending on engine coolant temperature, air conditioner operation status, vehicle speed, etc. | 1, 2, 3, 4   |
| A/C COMP REQ  | A/C switch OFF   |  | Off          |
|               | A/C switch ON  |  | On           |
| TAIL&CLR REQ  | Lighting switch OFF  |  | Off          |
|               | Lighting switch 1ST, 2ND, HI or AUTO (Light is illuminated)  |  | On           |
| HL LO REQ     | Lighting switch OFF  |  | Off          |
|               | Lighting switch 2ND HI or AUTO (Light is illuminated)  |  | On           |
| HL HI REQ     | Lighting switch OFF  |  | Off          |
|               | Lighting switch HI   |  | On           |
| FR FOG REQ    | Lighting switch 2ND  | Front fog lamp switch OFF  | Off          |
|               |  | Front fog lamp switch ON   | On           |
| FR WIP REQ    | Ignition switch ON   | Front wiper switch OFF   | Stop         |
|               |  | Front wiper switch INT   | 1LOW         |
|               |  | Front wiper switch LO  | Low          |
|               |  | Front wiper switch HI  | Hi           |
| WIP AUTO STOP | Ignition switch ON   | Front wiper stop position  | STOP P       |
|               |  | Any position other than front wiper stop position  | ACT P        |
| WIP PROT      | Ignition switch ON   | Front wiper operates normally  | Off          |
|               |  | Front wiper stops at fail-safe operation   | BLOCK        |
| ST RLY REQ    | Ignition switch OFF or ACC   |  | Off          |
|               | Ignition switch START  |  | On           |
| IGN RLY       | Ignition switch OFF or ACC   |  | Off          |
|               | Ignition switch ON   |  | On           |
| RR DEF REQ    | Rear defogger switch OFF   |  | Off          |
|               | Rear defogger switch ON  |  | On           |
| OIL P SW      | Ignition switch OFF, ACC or engine running   |  | Open         |
|               | Ignition switch ON   |  | Close        |
| DTRL REQ      | Daytime light system requested OFF with CONSULT-III.   |  | Off          |
|               | Daytime light system requested ON with CONSULT-III.  |  | On           |
| THFT HRN REQ  | Not operated   |  | Off          |
|               | <ul style="list-style-type: none"> <li>Panic alarm is activated</li> <li>Horn is activated with VEHICLE SECURITY (THEFT WARNING) SYSTEM</li> </ul> |  | On           |



# IPDM E/R (INTELLIGENT POWER DISTRIBUTION MODULE ENGINE ROOM)

< ECU DIAGNOSIS INFORMATION >

[IPDM E/R]

| Monitor Item | Condition                                  | Value/Status |
|--------------|--|--------------|
| HORN CHIRP   | Not operated                               | Off          |
|              | Door locking with keyfob (horn chirp mode) | On           |

## Terminal Layout

INFOID:000000006253987

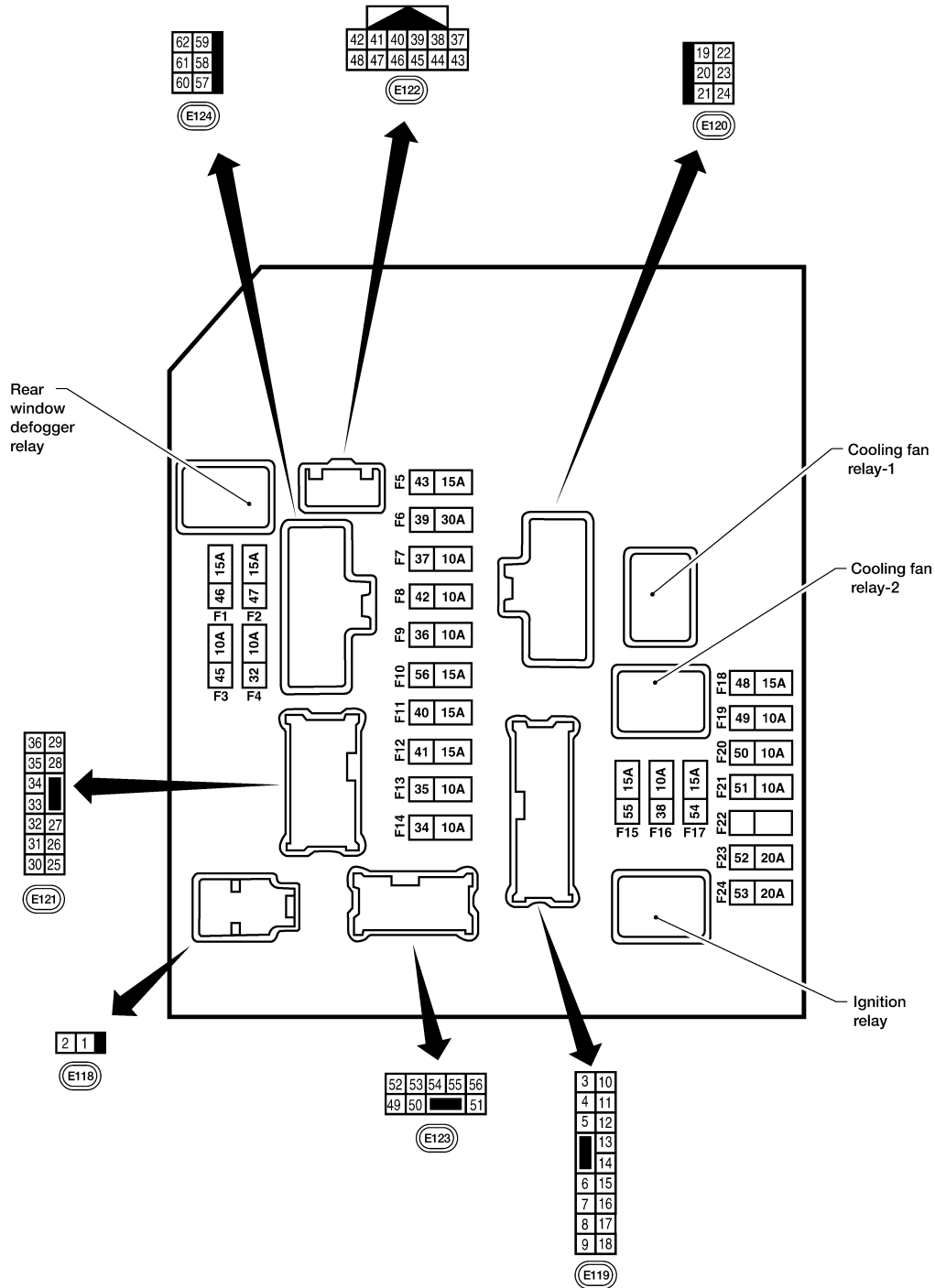

A  
B  
C  
D  
E  
F  
G  
H  
I  
J  
K  
L  
PCS  
N  
O  
P

# IPDM E/R (INTELLIGENT POWER DISTRIBUTION MODULE ENGINE ROOM)

< ECU DIAGNOSIS INFORMATION >

[IPDM E/R]

## Physical Values

INFOID:000000006253988

### PHYSICAL VALUES

| Terminal | Wire color | Signal name                        | Signal input/output | Measuring condition |                                      | Reference value (Approx.) |
|----------|------------|------------------------------------|---------------------|---------------------|--------------------------------------|---------------------------|
|          |            |                                    |                     | Ignition switch     | Operation or condition               |                           |
| 1        | W          | Battery power supply               | Input               | OFF                 | —                                    | Battery voltage           |
| 2        | R          | Battery power supply               | Input               | OFF                 | —                                    | Battery voltage           |
| 3        | G          | ECM relay                          | Output              | —                   | Ignition switch ON or START          | Battery voltage           |
|          |            |                                    |                     |                     | Ignition switch OFF or ACC           | 0V                        |
| 4        | P          | ECM relay                          | Output              | —                   | Ignition switch ON or START          | Battery voltage           |
|          |            |                                    |                     |                     | Ignition switch OFF or ACC           | 0V                        |
| 6        | V          | Throttle control motor relay       | Output              | —                   | Ignition switch ON or START          | Battery voltage           |
|          |            |                                    |                     |                     | Ignition switch OFF or ACC           | 0V                        |
| 7        | BR         | ECM relay control                  | Input               | —                   | Ignition switch ON or START          | 0V                        |
|          |            |                                    |                     |                     | Ignition switch OFF or ACC           | Battery voltage           |
| 8        | W/R        | Fuse 54                            | Output              | —                   | Ignition switch ON or START          | Battery voltage           |
|          |            |                                    |                     |                     | Ignition switch OFF or ACC           | 0V                        |
| 10       | R/B        | Fuse 45                            | Output              | ON                  | Daytime light system active          | 0V                        |
|          |            |                                    |                     |                     | Daytime light system inactive        | Battery voltage           |
| 11       | Y          | A/C compressor                     | Output              | ON or START         | A/C switch ON or defrost A/C switch  | Battery voltage           |
|          |            |                                    |                     |                     | A/C switch OFF or defrost A/C switch | 0V                        |
| 12       | W/G        | Ignition switch supplied power     | Input               | —                   | OFF or ACC                           | 0V                        |
|          |            |                                    |                     |                     | ON or START                          | Battery voltage           |
| 13       | R          | Fuel pump relay                    | Output              | —                   | Ignition switch ON or START          | Battery voltage           |
|          |            |                                    |                     |                     | Ignition switch OFF or ACC           | 0V                        |
| 14       | W/G        | Fuse 49                            | Output              | —                   | Ignition switch ON or START          | Battery voltage           |
|          |            |                                    |                     |                     | Ignition switch OFF or ACC           | 0V                        |
| 15       | W/R        | Fuse 50 (ABS)                      | Output              | —                   | Ignition switch ON or START          | Battery voltage           |
|          |            |                                    |                     |                     | Ignition switch OFF or ACC           | 0V                        |
| 16       | W/G        | Fuse 51                            | Output              | —                   | Ignition switch ON or START          | Battery voltage           |
|          |            |                                    |                     |                     | Ignition switch OFF or ACC           | 0V                        |
| 17       | W/G        | Fuse 55                            | Output              | —                   | Ignition switch ON or START          | Battery voltage           |
|          |            |                                    |                     |                     | Ignition switch OFF or ACC           | 0V                        |
| 19       | W          | Starter motor                      | Output              | START               | —                                    | Battery voltage           |
| 20       | BR         | Cooling fan motor (low)            | Output              | ON or START         | —                                    | Battery voltage           |
| 21       | GR         | Ignition switch supplied power     | Input               | —                   | OFF or ACC                           | 0V                        |
|          |            |                                    |                     |                     | START                                | Battery voltage           |
| 22       | G          | Battery power supply               | Output              | OFF                 | —                                    | Battery voltage           |
| 23       | LG         | Door mirror defogger output signal | Output              | —                   | When rear defogger switch is ON      | Battery voltage           |
|          |            |                                    |                     |                     | When raker defogger switch is OFF    | 0V                        |

# IPDM E/R (INTELLIGENT POWER DISTRIBUTION MODULE ENGINE ROOM)

< ECU DIAGNOSIS INFORMATION >

[IPDM E/R]

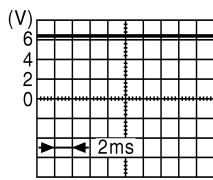
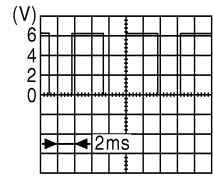
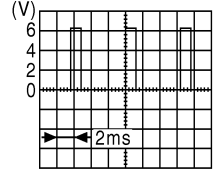
| Terminal | Wire color | Signal name                                 | Signal input/output | Measuring condition |  | Reference value (Approx.)  |
|----------|------------|---|---------------------|---------------------|--|--|
|          |            |   |                     | Ignition switch     | Operation or condition                                     |  |
| 24       | P          | Cooling fan motor (high)                    | Output              | —                   | Conditions correct for cooling fan operation               | Battery voltage  |
|          |            |   |                     |                     | Conditions not correct for cooling fan operation           | 0V   |
| 27       | W/G        | Fuse 38                                     | Output              | —                   | Ignition switch ON or START                                | Battery voltage  |
|          |            |   |                     |                     | Ignition switch OFF or ACC                                 | 0V   |
| 28       | R          | LH front parking and front side marker lamp | Output              | OFF                 | Lighting switch 1st position OFF                           | 0V   |
|          |            |   |                     |                     | Lighting switch 1st position ON                            | Battery voltage  |
| 29       | G          | Trailer tow relay                           | Output              | ON                  | Lighting switch 1st position OFF                           | 0V   |
|          |            |   |                     |                     | Lighting switch 1st position ON                            | Battery voltage  |
| 30       | R/B        | Fuse 53                                     | Output              | —                   | Ignition switch ON or START                                | Battery voltage  |
|          |            |   |                     |                     | Ignition switch OFF or ACC                                 | 0V   |
| 32       | GR         | Wiper low speed signal                      | Output              | ON or START         | Wiper switch OFF   | Battery voltage  |
|          |            |   |                     |                     | Wiper switch LO or INT                                     | 0V   |
| 35       | L          | Wiper high speed signal                     | Output              | ON or START         | Wiper switch OFF, LO, INT                                  | Battery voltage  |
|          |            |   |                     |                     | Wiper switch HI  | 0V   |
| 37       | Y          | Power generation command signal             | Output              | —                   | Ignition switch ON   |  <p style="text-align: center;">6.3 V</p> |
|          |            |   |                     |                     | 40% is set on "Active test," "ALTERNATOR DUTY" of "ENGINE" |  <p style="text-align: center;">3.8 V</p> |
|          |            |   |                     |                     | 40% is set on "Active test," "ALTERNATOR DUTY" of "ENGINE" |  <p style="text-align: center;">1.4 V</p> |
| 38       | B          | Ground                                      | Input               | —                   | —  | 0V   |
| 39       | L          | CAN-H                                       | —                   | ON                  | —  | —  |
| 40       | P          | CAN-L                                       | —                   | ON                  | —  | —  |
| 42       | GR         | Oil pressure switch                         | Input               | —                   | Engine running   | Battery voltage  |
|          |            |   |                     |                     | Engine stopped   | 0V   |

A  
B  
C  
D  
E  
F  
G  
H  
I  
J  
K  
L  
N  
O  
P

PCS

# IPDM E/R (INTELLIGENT POWER DISTRIBUTION MODULE ENGINE ROOM)

< ECU DIAGNOSIS INFORMATION >

[IPDM E/R]

| Terminal | Wire color | Signal name  | Signal input/output | Measuring condition |  |              | Reference value (Approx.) |
|----------|------------|--|---------------------|---------------------|--|--------------|---------------------------|
|          |            |  |                     | Ignition switch     | Operation or condition   |              |                           |
| 43       | G          | Wiper auto stop signal                                   | Input               | ON or START         | Wiper switch   | OFF, LO, INT | Battery voltage           |
| 44       | R          | Daytime light relay control (Canada only)                | Input               | ON                  | Daytime light system active  |              | 0V                        |
|          |            |  |                     |                     | Daytime light system inactive  |              | Battery voltage           |
| 45       | LG         | Horn relay control                                       | Input               | ON                  | When door locks are operated using keyfob (OFF → ON)*                                      |              | Battery voltage → 0V      |
| 46       | V          | Fuel pump relay control                                  | Input               | —                   | Ignition switch ON or START  |              | 0V                        |
|          |            |  |                     |                     | Ignition switch OFF or ACC   |              | Battery voltage           |
| 47       | O          | Throttle control motor relay control                     | Input               | —                   | Ignition switch ON or START  |              | 0V                        |
|          |            |  |                     |                     | Ignition switch OFF or ACC   |              | Battery voltage           |
| 48       | R          | Starter relay (range switch)                             | Input               | ON or START         | Selector lever in "P" or "N"   |              | 0V                        |
|          |            |  |                     |                     | Selector lever any other position  |              | Battery voltage           |
| 49       | GR         | Front RH parking and front side marker lamp              | Output              | OFF                 | Lighting switch 1st position   | OFF          | 0V                        |
|          |            |  |                     |                     |  | ON           | Battery voltage           |
| 50       | W          | Front fog lamp (LH)                                      | Output              | ON or START         | Lighting switch must be in the 2nd position (LOW beam is ON) and the front fog lamp switch | OFF          | 0V                        |
|          |            |  |                     |                     |  | ON           | Battery voltage           |
| 51       | V          | Front fog lamp (RH)                                      | Output              | ON or START         | Lighting switch must be in the 2nd position (LOW beam is ON) and the front fog lamp switch | OFF          | 0V                        |
|          |            |  |                     |                     |  | ON           | Battery voltage           |
| 52       | P          | LH low beam head-lamp                                    | Output              | —                   | Lighting switch in 2nd position  |              | Battery voltage           |
| 54       | R          | RH low beam head-lamp                                    | Output              | —                   | Lighting switch in 2nd position  |              | Battery voltage           |
| 55       | G          | LH high beam head-lamp                                   | Output              | —                   | Lighting switch in 2nd position and placed in HIGH or PASS position                        |              | Battery voltage           |
| 56       | L          | RH high beam head-lamp                                   | Output              | —                   | Lighting switch in 2nd position and placed in HIGH or PASS position                        |              | Battery voltage           |
| 57       | GR         | Parking, license and tail lamps and off-road lamp switch | Output              | ON                  | Lighting switch 1st position   | OFF          | 0V                        |
|          |            |  |                     |                     |  | ON           | Battery voltage           |
| 59       | B          | Ground   | Input               | —                   | —  |              | 0V                        |
| 60       | GR         | Rear window defogger relay                               | Output              | ON or START         | Rear defogger switch ON  |              | Battery voltage           |
|          |            |  |                     |                     | Rear defogger switch OFF   |              | 0V                        |
| 61       | R/B        | Fuse 32  | Output              | OFF                 | —  |              | Battery voltage           |

\*: When horn reminder is ON

# IPDM E/R (INTELLIGENT POWER DISTRIBUTION MODULE ENGINE ROOM)

< ECU DIAGNOSIS INFORMATION >

[IPDM E/R]

## Fail Safe

INFOID:000000006253990

### CAN COMMUNICATION CONTROL

When CAN communication with ECM and BCM is impossible, IPDM E/R performs fail-safe control. After CAN communication recovers normally, it also returns to normal control.

If No CAN Communication Is Available With ECM

| Control part | Fail-safe in operation  |
|--------------|---|
| Cooling fan  | <ul style="list-style-type: none"><li>• Turns ON the cooling fan relay when the ignition switch is turned ON</li><li>• Turns OFF the cooling fan relay when the ignition switch is turned OFF</li></ul> |

If No CAN Communication Is Available With BCM

| Control part   | Fail-safe in operation  |
|--|---|
| Headlamp   | <ul style="list-style-type: none"><li>• Turns ON the headlamp low relay when the ignition switch is turned ON</li><li>• Turns OFF the headlamp low relay when the ignition switch is turned OFF</li><li>• Headlamp (LH/RH) high relays OFF</li></ul>  |
| <ul style="list-style-type: none"><li>• Parking lamps</li><li>• License plate lamps</li><li>• Tail lamps</li></ul> | <ul style="list-style-type: none"><li>• Turns ON the tail lamp relay when the ignition switch is turned ON</li><li>• Turns OFF the tail lamp relay when the ignition switch is turned OFF</li></ul>   |
| Front wiper  | <ul style="list-style-type: none"><li>• The status just before activation of fail-safe control is maintained until the ignition switch is turned OFF while the front wiper is operating at LO or HI speed.</li><li>• The wiper is operated at LO speed until the ignition switch is turned OFF if the fail-safe control is activated while the front wiper is set in the INT mode and the front wiper motor is operating.</li></ul> |
| Rear window defogger   | Rear window defogger relay OFF  |
| A/C compressor   | A/C relay OFF   |
| Front fog lamps (if equipped)  | Front fog lamp relay OFF  |

### IGNITION RELAY MALFUNCTION DETECTION FUNCTION

- IPDM E/R monitors the voltage at the contact circuit and excitation coil circuit of the ignition relay inside it.
- IPDM E/R judges the ignition relay error if the voltage differs between the contact circuit and the excitation coil circuit.
- If the ignition relay cannot turn OFF due to contact seizure, it activates the tail lamp relay for 10 minutes to alert the user to the ignition relay malfunction when the ignition switch is turned OFF.

| Ignition switch | Ignition relay | Tail lamp relay |
|-----------------|----------------|-----------------|
| ON              | ON             | —               |
| OFF             | OFF            | —               |

#### NOTE:

The tail lamp turns OFF when the ignition switch is turned ON.

### FRONT WIPER CONTROL

IPDM E/R detects front wiper stop position by a front wiper auto stop signal.

When a front wiper auto stop signal is in the conditions listed below, IPDM E/R stops power supply to wiper after repeating a front wiper 10 second activation and 20 second stop five times.

| Ignition switch | Front wiper switch | Auto stop signal   |
|-----------------|--------------------|--|
| ON              | OFF                | Front wiper stop position signal cannot be input 10 seconds. |
|                 | ON                 | The signal does not change for 10 seconds.                   |

#### NOTE:

This operation status can be confirmed on the IPDM E/R "DATA MONITOR" that displays "Block" for the item "WIP PROT" while the wiper is stopped.

### STARTER MOTOR PROTECTION FUNCTION

A  
B  
C  
D  
E  
F  
G  
H  
I  
J  
K  
L  
N  
O  
P

PCS

# IPDM E/R (INTELLIGENT POWER DISTRIBUTION MODULE ENGINE ROOM)

< ECU DIAGNOSIS INFORMATION >

[IPDM E/R]

IPDM E/R turns OFF the starter control relay to protect the starter motor when the starter control relay remains active for 90 seconds.

## DTC Index

INFOID:000000006253991

| CONSULT-III display  | Fail-safe | TIME <sup>NOTE</sup> |        | Refer to               |
|--|-----------|----------------------|--------|------------------------|
| No DTC is detected.<br>further testing<br>may be required. | —         | —                    | —      | —                      |
| U1000: CAN COMM CIRCUIT                                    | ×         | CRNT                 | 1 – 39 | <a href="#">PCS-14</a> |

### NOTE:

The details of TIME display are as follows.

- CRNT: The malfunctions that are detected now
- 1 - 39: The number is indicated when it is normal at present and a malfunction was detected in the past. It increases like 0 → 1 → 2 ··· 38 → 39 after returning to the normal condition whenever IGN OFF → ON. It is fixed to 39 until the self-diagnosis results are erased if it is over 39. It returns to 0 when a malfunction is detected again in the process.

# IPDM E/R (INTELLIGENT POWER DISTRIBUTION MODULE ENGINE ROOM)

< WIRING DIAGRAM >

[IPDM E/R]

## WIRING DIAGRAM

### IPDM E/R (INTELLIGENT POWER DISTRIBUTION MODULE ENGINE ROOM)

#### Wiring Diagram

INFOID:000000006706719

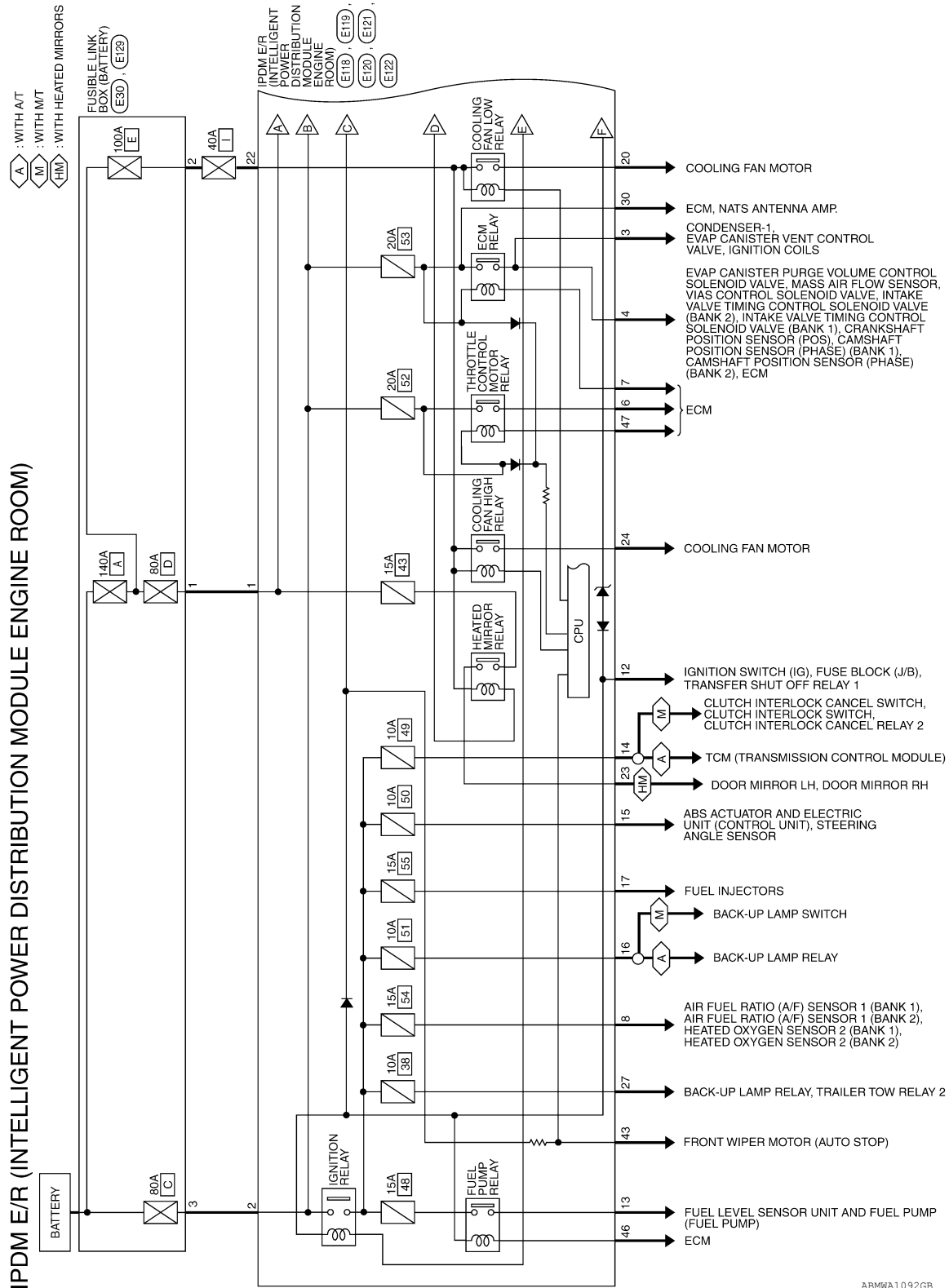

ABMWA1092GB

A  
B  
C  
D  
E  
F  
G  
H  
I  
J  
K  
L  
N  
O  
P

PCS

# IPDM E/R (INTELLIGENT POWER DISTRIBUTION MODULE ENGINE ROOM)

< WIRING DIAGRAM >

[IPDM E/R]

- (A) : WITH A/T
- (FL) : WITH FRONT FOG LAMPS
- (M) : WITH M/T
- (N) : FOR CANADA

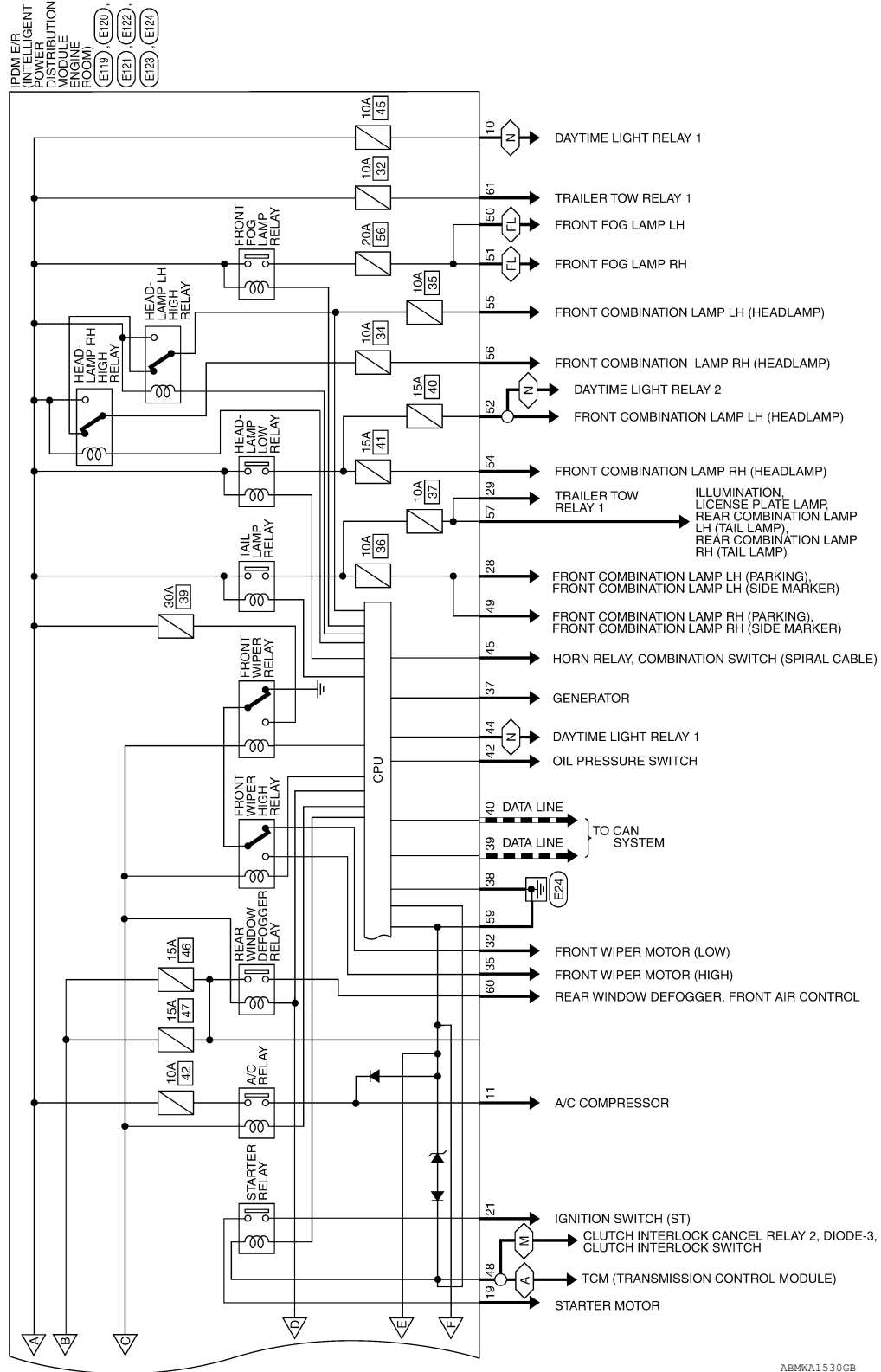

ABMWA1530GB



IPDM E/R (INTELLIGENT POWER DISTRIBUTION MODULE ENGINE ROOM) CONNECTORS

|                 |                            |
|-----------------|----------------------------|
| Connector No.   | E30                        |
| Connector Name  | FUSIBLE LINK BOX (BATTERY) |
| Connector Color | -                          |



| Terminal No. | Color of Wire | Signal Name |
|--------------|---------------|-------------|
| 3            | R             | -           |

|                 |  |
|-----------------|--|
| Connector No.   | E118   |
| Connector Name  | IPDM E/R (INTELLIGENT POWER DISTRIBUTION MODULE ENGINE ROOM) |
| Connector Color | BLACK  |



| Terminal No. | Color of Wire | Signal Name |
|--------------|---------------|-------------|
| 1            | W             | F/L USM     |
| 2            | R             | F/L MAIN    |

|                 |  |
|-----------------|--|
| Connector No.   | E119   |
| Connector Name  | IPDM E/R (INTELLIGENT POWER DISTRIBUTION MODULE ENGINE ROOM) |
| Connector Color | WHITE  |



| Terminal No. | Color of Wire | Signal Name |
|--------------|---------------|-------------|
| 3            | G             | IGN COIL    |
| 4            | P             | ECM         |
| 5            | -             | -           |
| 6            | V             | ETC         |

| Terminal No. | Color of Wire | Signal Name        |
|--------------|---------------|--------------------|
| 7            | BR            | ECM RLY CONT       |
| 8            | W/R           | O2 SENSOR          |
| 9            | -             | -                  |
| 10           | R/B           | DTRL RLY SUPPLY    |
| 11           | Y             | A/C COMPRESSOR     |
| 12           | W/G           | IGN SW (IG)        |
| 13           | R             | FUEL PUMP          |
| 14           | W/G           | A/T ECU IGN SUPPLY |
| 15           | W/R           | ABS IGN SUPPLY     |
| 16           | W/G           | REVERSE LAMP       |
| 17           | W/G           | INJECTOR           |
| 18           | -             | -                  |

|                 |  |
|-----------------|--|
| Connector No.   | E120   |
| Connector Name  | IPDM E/R (INTELLIGENT POWER DISTRIBUTION MODULE ENGINE ROOM) |
| Connector Color | WHITE  |



| Terminal No. | Color of Wire | Signal Name   |
|--------------|---------------|---------------|
| 19           | W             | STARTER MTR   |
| 20           | BR            | MOTOR FAN 1   |
| 21           | GR            | IGN SW (ST)   |
| 22           | G             | F/L MOTOR FAN |
| 23           | LG            | HEATED MIRROR |
| 24           | P             | MOTOR FAN 2   |

ABMIA1496GB

# IPDM E/R (INTELLIGENT POWER DISTRIBUTION MODULE ENGINE ROOM)

< WIRING DIAGRAM >

[IPDM E/R]

|                 |  |
|-----------------|--|
| Connector No.   | E123   |
| Connector Name  | IPDM E/R (INTELLIGENT POWER DISTRIBUTION MODULE ENGINE ROOM) |
| Connector Color | BROWN  |



|    |    |    |
|----|----|----|
| 51 | 50 | 49 |
| 56 | 55 | 54 |
| 53 | 52 | 51 |

| Terminal No. | Color of Wire | Signal Name    |
|--------------|---------------|----------------|
| 49           | GR            | ILLUMINATION   |
| 50           | W             | FR FOG LAMP LH |
| 51           | V             | FR FOG LAMP RH |
| 52           | P             | H/LAMP LO LH   |
| 53           | -             | -              |
| 54           | R             | H/LAMP LO RH   |
| 55           | G             | H/LAMP HI LH   |
| 56           | L             | H/LAMP HI RH   |

|                 |  |
|-----------------|--|
| Connector No.   | E122   |
| Connector Name  | IPDM E/R (INTELLIGENT POWER DISTRIBUTION MODULE ENGINE ROOM) |
| Connector Color | WHITE  |



|    |    |    |    |    |    |
|----|----|----|----|----|----|
| 42 | 41 | 40 | 39 | 38 | 37 |
| 48 | 47 | 46 | 45 | 44 | 43 |

| Terminal No. | Color of Wire | Signal Name        |
|--------------|---------------|--------------------|
| 37           | Y             | ALT-C CONT         |
| 38           | B             | GND (SIGNAL)       |
| 39           | L             | CAN-H              |
| 40           | P             | CAN-L              |
| 41           | -             | -                  |
| 42           | GR            | OIL PRESSURE SW    |
| 43           | G             | AUTO STOP SW       |
| 44           | R             | DTRL RLY CONT      |
| 45           | LG            | ANT THEFT HORN     |
| 46           | V             | FUEL PUMP RLY CONT |
| 47           | O             | ETC RLY CONT       |
| 48           | R             | RANGE SW           |

|                 |  |
|-----------------|--|
| Connector No.   | E121   |
| Connector Name  | IPDM E/R (INTELLIGENT POWER DISTRIBUTION MODULE ENGINE ROOM) |
| Connector Color | BROWN  |



|    |    |    |    |    |
|----|----|----|----|----|
| 28 | 28 | 27 | 26 | 25 |
| 36 | 35 | 34 | 33 | 32 |
| 31 | 30 |    |    |    |

| Terminal No. | Color of Wire | Signal Name      |
|--------------|---------------|------------------|
| 25           | -             | -                |
| 26           | -             | -                |
| 27           | W/G           | TTOW REV LAMP    |
| 28           | R             | ILLUMINATION     |
| 29           | G             | TRAILER RLY CONT |
| 30           | R/B           | ECM BAT          |
| 31           | -             | -                |
| 32           | GR            | FR WIPER LO      |
| 33           | -             | -                |
| 34           | -             | -                |
| 35           | L             | FR WIPER HI      |
| 36           | -             | -                |

|                 |                            |
|-----------------|----------------------------|
| Connector No.   | E129                       |
| Connector Name  | FUSIBLE LINK BOX (BATTERY) |
| Connector Color | BLACK                      |



|   |   |
|---|---|
| 2 | 1 |
|---|---|

| Terminal No. | Color of Wire | Signal Name |
|--------------|---------------|-------------|
| 1            | W             | -           |
| 2            | R             | -           |

| Terminal No. | Color of Wire | Signal Name      |
|--------------|---------------|------------------|
| 57           | GR            | TAIL LAMP        |
| 58           | -             | -                |
| 59           | B             | GND (POWER)      |
| 60           | GR            | RR DEF           |
| 61           | R/B           | TRAIL RLY SUPPLY |
| 62           | -             | -                |

|                 |  |
|-----------------|--|
| Connector No.   | E124   |
| Connector Name  | IPDM E/R (INTELLIGENT POWER DISTRIBUTION MODULE ENGINE ROOM) |
| Connector Color | BLACK  |



|    |    |    |
|----|----|----|
| 59 | 58 | 57 |
| 62 | 61 | 60 |

ABMIA2566GB

# PRECAUTION

## PRECAUTIONS

### Precaution for Supplemental Restraint System (SRS) "AIR BAG" and "SEAT BELT PRE-TENSIONER"

INFOID:000000006253992

The Supplemental Restraint System such as "AIR BAG" and "SEAT BELT PRE-TENSIONER", used along with a front seat belt, helps to reduce the risk or severity of injury to the driver and front passenger for certain types of collision. This system includes seat belt switch inputs and dual stage front air bag modules. The SRS system uses the seat belt switches to determine the front air bag deployment, and may only deploy one front air bag, depending on the severity of a collision and whether the front occupants are belted or unbelted. Information necessary to service the system safely is included in the SR and SB section of this Service Manual.

**WARNING:**

- To avoid rendering the SRS inoperative, which could increase the risk of personal injury or death in the event of a collision which would result in air bag inflation, all maintenance must be performed by an authorized NISSAN/INFINITI dealer.
- Improper maintenance, including incorrect removal and installation of the SRS, can lead to personal injury caused by unintentional activation of the system. For removal of Spiral Cable and Air Bag Module, see the SR section.
- Do not use electrical test equipment on any circuit related to the SRS unless instructed to in this Service Manual. SRS wiring harnesses can be identified by yellow and/or orange harnesses or harness connectors.

### PRECAUTIONS WHEN USING POWER TOOLS (AIR OR ELECTRIC) AND HAMMERS

**WARNING:**

- When working near the Airbag Diagnosis Sensor Unit or other Airbag System sensors with the Ignition ON or engine running, DO NOT use air or electric power tools or strike near the sensor(s) with a hammer. Heavy vibration could activate the sensor(s) and deploy the air bag(s), possibly causing serious injury.
- When using air or electric power tools or hammers, always switch the Ignition OFF, disconnect the battery, and wait at least 3 minutes before performing any service.

A  
B  
C  
D  
E  
F  
G  
H  
I  
J  
K  
L

PCS

N  
O  
P

## BCM (BODY CONTROL MODULE)

< REMOVAL AND INSTALLATION >

[IPDM E/R]

---

# REMOVAL AND INSTALLATION

## BCM (BODY CONTROL MODULE)

### Removal and Installation

INFOID:000000006253993

Refer to [BCS-53, "Removal and Installation"](#).

## UNIT REMOVAL AND INSTALLATION

### IPDM E/R (INTELLIGENT POWER DISTRIBUTION MODULE ENGINE ROOM)

#### Removal and Installation of IPDM E/R

INFOID:000000006253994

#### REMOVAL

##### **CAUTION:**

**Never remove the relays from the IPDM E/R. Tampering with the relays may cause additional incidents with the vehicle.**

1. Disconnect negative battery terminal.
2. Remove IPDM E/R upper cover.

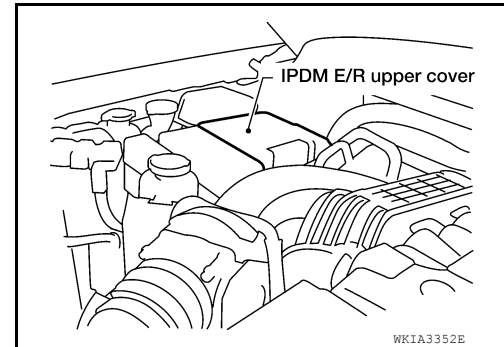

3. Release 2 clips and pull IPDM E/R up from case.
4. Disconnect IPDM E/R connectors and remove the IPDM E/R.

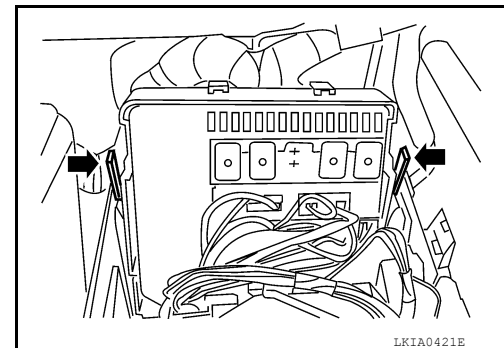

#### INSTALLATION

Installation is in the reverse order of removal.

A  
B  
C  
D  
E  
F  
G  
H  
I  
J  
K  
L

PCS