

SECTION **CHG**
CHARGING SYSTEM

A
B
C
D
E
F
G
H
I
J
K
L
N
O
P

CONTENTS

PRECAUTION	2	POWER GENERATION VOLTAGE VARIABLE CONTROL SYSTEM OPERATION INSPECTION	9
PRECAUTIONS	2	Diagnosis Procedure	9
Precaution for Supplemental Restraint System (SRS) "AIR BAG" and "SEAT BELT PRE-TENSIONER"	2	B TERMINAL CIRCUIT	11
Precaution for Power Generation Variable Voltage Control System	2	Description	11
Precaution for Work	2	Diagnosis Procedure	11
PREPARATION	4	L TERMINAL CIRCUIT	12
PREPARATION	4	Description	12
Special Service Tool	4	Diagnosis Procedure	12
Commercial Service Tool	4	S TERMINAL CIRCUIT	13
BASIC INSPECTION	5	Description	13
DIAGNOSIS AND REPAIR WORKFLOW	5	Diagnosis Procedure	13
Work Flow	5	WIRING DIAGRAM	14
SYSTEM DESCRIPTION	6	CHARGING SYSTEM	14
CHARGING SYSTEM	6	Wiring Diagram	14
System Diagram	6	SYMPTOM DIAGNOSIS	19
System Description	6	CHARGING SYSTEM	19
Component Description	6	Symptom Table	19
POWER GENERATION VOLTAGE VARIABLE CONTROL SYSTEM	7	REMOVAL AND INSTALLATION	20
System Diagram	7	GENERATOR	20
System Description	7	Exploded View	20
Component Description	7	Removal and Installation	20
DTC/CIRCUIT DIAGNOSIS	8	SERVICE DATA AND SPECIFICATIONS (SDS)	22
CHARGING SYSTEM PRELIMINARY INSPECTION	8	SERVICE DATA AND SPECIFICATIONS (SDS)	22
Diagnosis Procedure	8	Generator	22

CHG

PRECAUTIONS

< PRECAUTION >

PRECAUTION

PRECAUTIONS

Precaution for Supplemental Restraint System (SRS) "AIR BAG" and "SEAT BELT PRE-TENSIONER"

INFOID:000000007360868

The Supplemental Restraint System such as "AIR BAG" and "SEAT BELT PRE-TENSIONER", used along with a front seat belt, helps to reduce the risk or severity of injury to the driver and front passenger for certain types of collision. This system includes seat belt switch inputs and dual stage front air bag modules. The SRS system uses the seat belt switches to determine the front air bag deployment, and may only deploy one front air bag, depending on the severity of a collision and whether the front occupants are belted or unbelted. Information necessary to service the system safely is included in the SR and SB section of this Service Manual.

WARNING:

- To avoid rendering the SRS inoperative, which could increase the risk of personal injury or death in the event of a collision which would result in air bag inflation, all maintenance must be performed by an authorized NISSAN/INFINITI dealer.
- Improper maintenance, including incorrect removal and installation of the SRS, can lead to personal injury caused by unintentional activation of the system. For removal of Spiral Cable and Air Bag Module, see the SR section.
- Do not use electrical test equipment on any circuit related to the SRS unless instructed to in this Service Manual. SRS wiring harnesses can be identified by yellow and/or orange harnesses or harness connectors.

PRECAUTIONS WHEN USING POWER TOOLS (AIR OR ELECTRIC) AND HAMMERS

WARNING:

- When working near the Airbag Diagnosis Sensor Unit or other Airbag System sensors with the Ignition ON or engine running, DO NOT use air or electric power tools or strike near the sensor(s) with a hammer. Heavy vibration could activate the sensor(s) and deploy the air bag(s), possibly causing serious injury.
- When using air or electric power tools or hammers, always switch the Ignition OFF, disconnect the battery, and wait at least 3 minutes before performing any service.

Precaution for Power Generation Variable Voltage Control System

INFOID:000000007360869

CAUTION:

For this model, the battery current sensor that is installed to the negative battery cable measures the charging/discharging current of the battery and performs various engine controls. If an electrical component is connected directly to the negative battery terminal, the current flowing through that component will not be measured by the battery current sensor. This condition may cause a malfunction of the engine control system and battery discharge may occur. Do not connect an electrical component or ground wire directly to the battery terminal.

Precaution for Work

INFOID:000000007360870

- When removing or disassembling each component, be careful not to damage or deform it. If a component may be subject to interference, be sure to protect it with a shop cloth.
- When removing (disengaging) components with a screwdriver or similar tool, be sure to wrap the component with a shop cloth or vinyl tape to protect it.
- Protect the removed parts with a shop cloth and prevent them from being dropped.
- Replace a deformed or damaged clip.
- If a part is specified as a non-reusable part, always replace it with new one.
- Be sure to tighten bolts and nuts securely to the specified torque.
- After installation is complete, be sure to check that each part works properly.
- Follow the steps below to clean components.
 - Water soluble dirt: Dip a soft cloth into lukewarm water, and wring the water out of the cloth to wipe the dirty area.
Then rub with a soft and dry cloth.
 - Oily dirt: Dip a soft cloth into lukewarm water with mild detergent (concentration: within 2 to 3%), and wipe the dirty area.

PRECAUTIONS

< PRECAUTION >

Then dip a cloth into fresh water, and wring the water out of the cloth to wipe the detergent off. Then rub with a soft and dry cloth.

- Do not use organic solvent such as thinner, benzene, alcohol, or gasoline.
- For genuine leather seats, use a genuine leather seat cleaner.

A

B

C

D

E

F

G

H

I

J

K

L

CHG

N

O

P

PREPARATION

< PREPARATION >

PREPARATION

PREPARATION

Special Service Tool

INFOID:000000007360871

The actual shapes of Kent-Moore tools may differ from those of special service tools illustrated here.

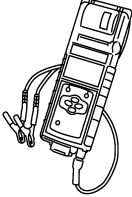
Tool number (Kent-Moore No.) Tool name	Description
<p>— (—) Model GR8-1200 NI Multitasking battery and electrical diagnostic station</p>  <p style="text-align: right; font-size: small;">AWIIA12392Z</p>	<p>Tests batteries, starting and charging systems and charges batteries. For operating instructions, refer to diagnostic station instruction manual.</p>
<p>— (—) Model EXP-800 NI Battery and electrical diagnostic analyzer</p>  <p style="text-align: right; font-size: small;">JSMIA08062Z</p>	<p>Tests batteries and charging systems. For operating instructions, refer to diagnostic analyzer instruction manual.</p>

Commercial Service Tool

INFOID:000000007360872

Tool name	Description
<p>Power tool</p>  <p style="text-align: right; font-size: small;">PIIB1407E</p>	<p>Loosening bolts, screws and nut.</p>

DIAGNOSIS AND REPAIR WORKFLOW

< BASIC INSPECTION >

BASIC INSPECTION

DIAGNOSIS AND REPAIR WORKFLOW

Work Flow

INFOID:000000007360873

OVERALL SEQUENCE

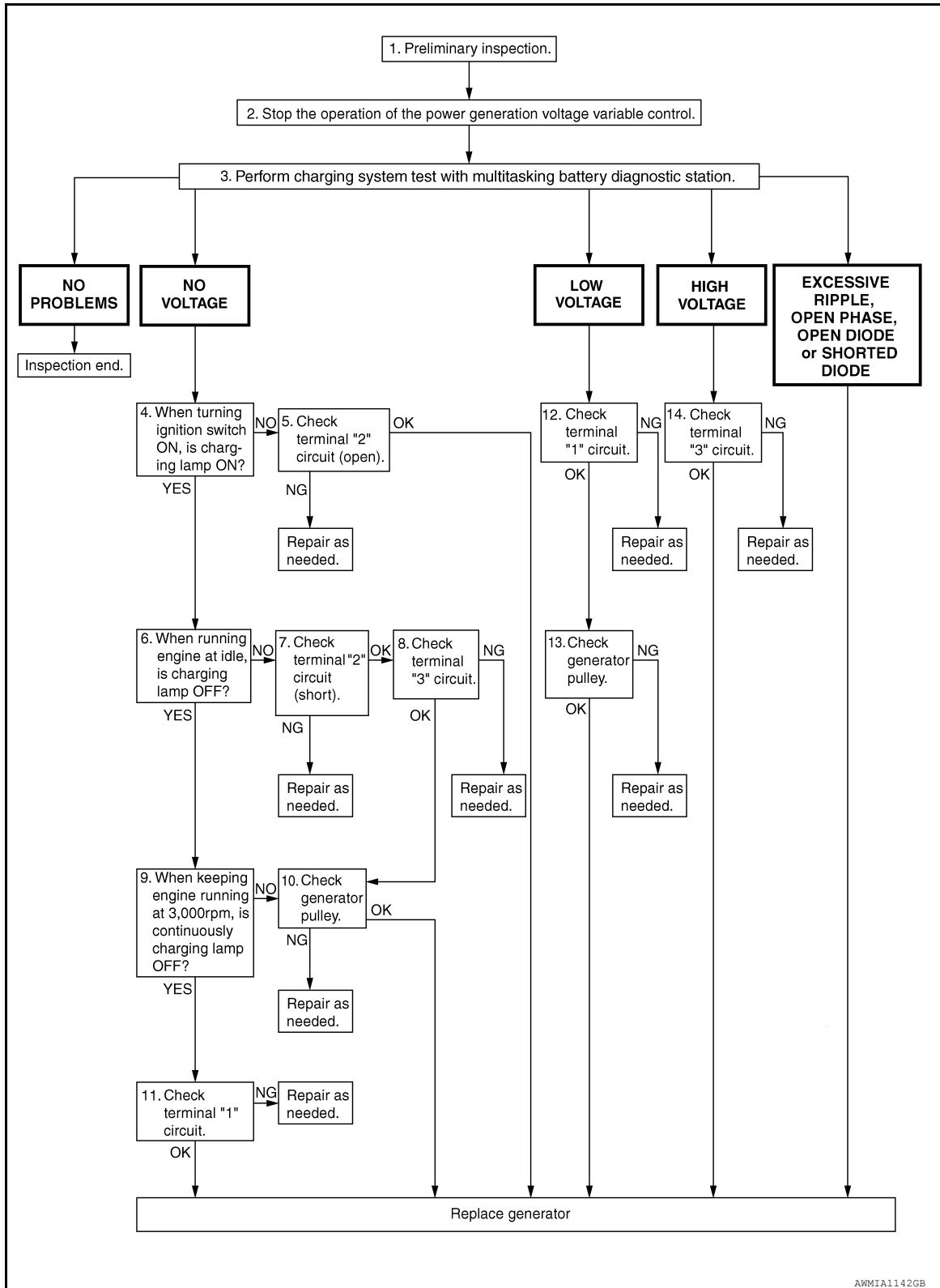

AWMIA1142GB

A
B
C
D
E
F
G
H
I
J
K
L
CHG
N
O
P

CHARGING SYSTEM

< SYSTEM DESCRIPTION >

SYSTEM DESCRIPTION

CHARGING SYSTEM

System Diagram

INFOID:000000007360874

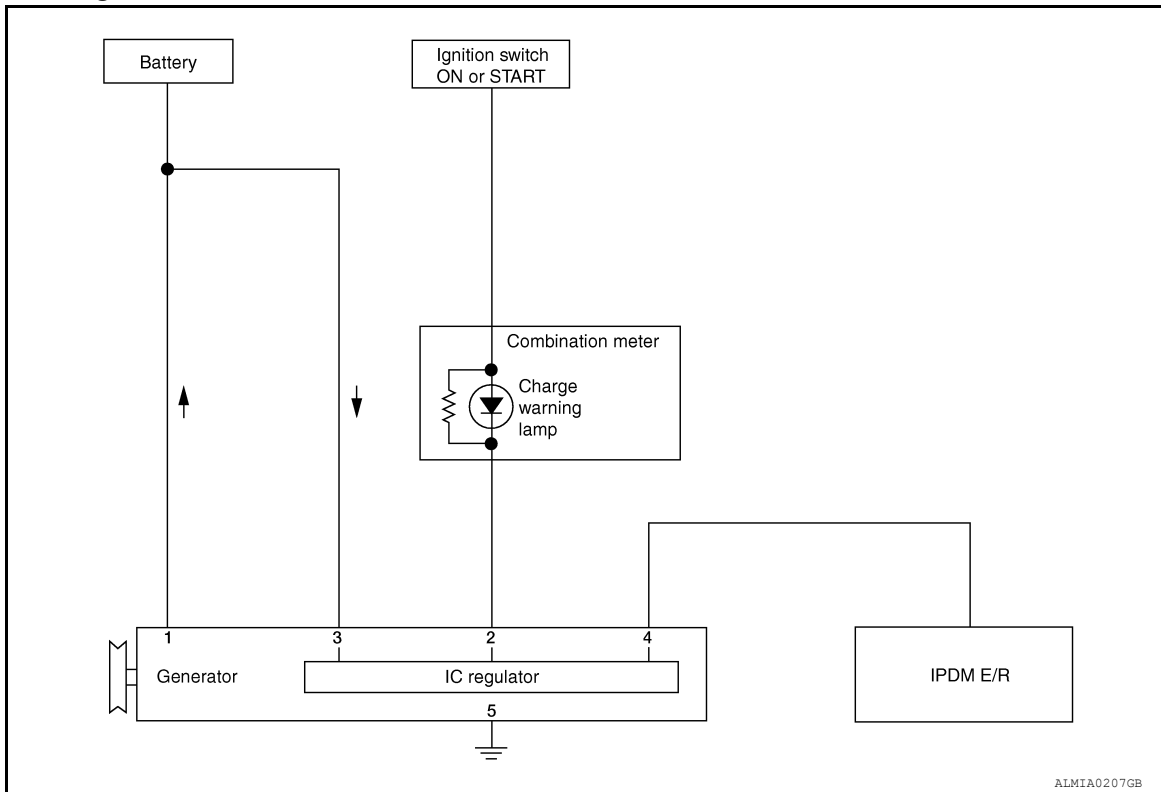

ALMIA0207GB

System Description

INFOID:000000007360875

The generator provides DC voltage to operate the vehicle's electrical system and to keep the battery charged. The voltage output is controlled by the IC regulator.

Component Description

INFOID:000000007360876

Component part		Description
Generator	Terminal "1"	Refer to CHG-11, "Description" .
	Terminal "2"	Refer to CHG-12, "Description" .
	Terminal "3"	Refer to CHG-13, "Description" .
	Terminal "4"	Used for the power generation voltage variable control system. Refer to CHG-7, "System Description" .
Combination meter (Charge warning lamp)		The IC regulator warning function activates to illuminate the charge warning lamp if any of the following symptoms occur while generator is operating: <ul style="list-style-type: none"> Excessive voltage is produced. No voltage is produced.
IPDM E/R		Used for the power generation voltage variable control system. Refer to CHG-7, "System Description" .

POWER GENERATION VOLTAGE VARIABLE CONTROL SYSTEM

< SYSTEM DESCRIPTION >

POWER GENERATION VOLTAGE VARIABLE CONTROL SYSTEM

System Diagram

INFOID:000000007360877

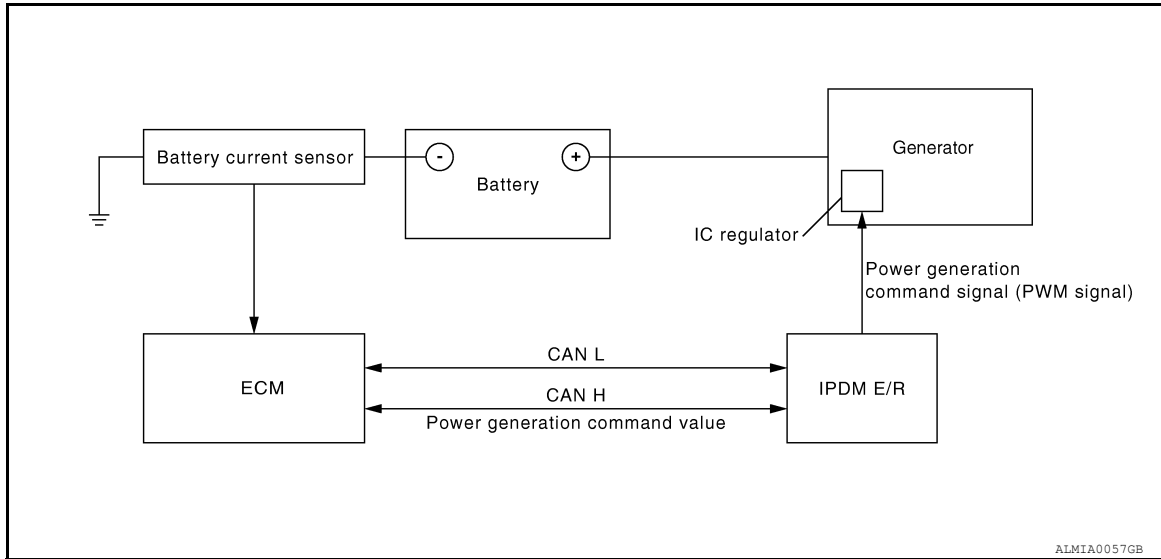

ALMIA0057GB

System Description

INFOID:000000007360878

Power generation variable voltage control system has been adopted. By varying the voltage to the generator, engine load due to power generation of the generator is reduced and fuel consumption is decreased.

NOTE:

When any malfunction is detected in the power generation variable voltage control system, power generation is performed according to the characteristic of the IC regulator in the generator.

Component Description

INFOID:000000007360879

Component part	Description
Battery current sensor	The battery current sensor is installed on the battery cable at the negative terminal. The battery current sensor detects the charging/discharging current of the battery and sends a voltage signal to the ECM according to the current value detected.
ECM	The battery current sensor detects the charging/discharging current of the battery. The ECM judges the battery condition based on this signal. The ECM judges whether to request more output via the power generation voltage variable control according to the battery condition. When performing the power generation voltage variable control, the ECM calculates the target power generation voltage according to the battery condition and sends the calculated value as the power generation command value to the IPDM E/R.
IPDM E/R	The IPDM E/R converts the received power generation command value into a pulse width modulated (PWM) command signal and sends it to the IC regulator.
Generator (IC regulator)	The IC regulator controls the power generation voltage by the target power generation voltage based on the received PWM command signal. When there is no PWM command signal, the generator performs the normal power generation according to the characteristic of the IC regulator.

CHARGING SYSTEM PRELIMINARY INSPECTION

< DTC/CIRCUIT DIAGNOSIS >

DTC/CIRCUIT DIAGNOSIS

CHARGING SYSTEM PRELIMINARY INSPECTION

Diagnosis Procedure

INFOID:000000007360880

1. CHECK BATTERY TERMINALS CONNECTION

Check if battery terminals are clean and tight.

Is the inspection result normal?

YES >> GO TO 2

NO >> Repair battery terminals connection.

2. CHECK FUSE

Check for blown fuse and fusible link.

Unit	Power source (Power supply terminals)	Fuse or Fusible Link
Generator	Battery (terminal 3)	Fuse 30
	Battery (terminal 1)	Fusible Link A
Combination meter	Ignition switch ON (terminal 2)	Fuse 14

Is the inspection result normal?

YES >> GO TO 3

NO >> Be sure to eliminate cause of malfunction before installing new fuse or fusible link.

3. CHECK GENERATOR GROUND TERMINAL CONNECTION

Verify connector E209 terminal 5 (generator ground harness) is clean and tight.

Is the inspection result normal?

YES >> GO TO 4

NO >> Repair connection.

4. CHECK DRIVE BELT TENSION

Check drive belt tension. Refer to [EM-13. "Checking Drive Belts"](#).

Is the inspection result normal?

YES >> Inspection End.

NO >> Repair as needed.

POWER GENERATION VOLTAGE VARIABLE CONTROL SYSTEM OPERATION INSPECTION

< DTC/CIRCUIT DIAGNOSIS >

POWER GENERATION VOLTAGE VARIABLE CONTROL SYSTEM OPERATION INSPECTION

Diagnosis Procedure

INFOID:000000007360881

Regarding Wiring Diagram information, refer to [CHG-14. "Wiring Diagram"](#).

CAUTION:

When performing this inspection, always use a charged battery that has completed the battery inspection. (When the charging rate of the battery is low, the response speed of the voltage change will become slow. This can cause an incorrect inspection.)

1. CHECK ECM (CONSULT)

Perform ECM self-diagnosis with CONSULT. Refer to [EC-52. "CONSULT Function"](#).

Self-diagnostic results content

No malfunction detected>> GO TO 2

Malfunction detected>> Check applicable parts, and repair or replace corresponding parts.

2. CHECK OPERATION OF POWER GENERATION VOLTAGE VARIABLE CONTROL SYSTEM

1. Connect CONSULT and start the engine.
2. The selector lever is in "P" or "N" position and all of the electric loads and A/C, etc. are turned OFF.
3. Select "ALTERNATOR DUTY" in "Active Test" of "ENGINE", and then check the value of "BATTERY VOLT" monitor when DUTY value of "ALTERNATOR DUTY" is set to 40.0 %.

"BATTERY VOLT"

2 seconds after setting the DUTY value of "ALTERNATOR DUTY" to 40.0 % : 12 - 13.6 V

4. Check the value of "BATTERY VOLT" monitor when DUTY value of "ALTERNATOR DUTY" is set to 80.0%.

"BATTERY VOLT"

20 seconds after setting the DUTY value of "ALTERNATOR DUTY" to 80.0 % : +0.5 V or more against the value of "BATTERY VOLT" monitor when DUTY value is 40.0 %

Is the measurement value within specification?

YES >> Inspection End.

NO >> GO TO 3

3. CHECK IPDM E/R (CONSULT)

Perform IPDM E/R self-diagnosis with CONSULT. Refer to [EC-52. "CONSULT Function"](#).

Self-diagnostic results content

No malfunction detected>> GO TO 4

Malfunction detected>> Check applicable parts, and repair or replace corresponding parts.

4. CHECK HARNESS BETWEEN GENERATOR AND IPDM E/R

POWER GENERATION VOLTAGE VARIABLE CONTROL SYSTEM OPERATION INSPECTION

< DTC/CIRCUIT DIAGNOSIS >

1. Turn ignition switch OFF.
2. Disconnect generator connector E205 and IPDM E/R connector E122.
3. Check continuity between generator harness connector E205 (A) terminal 4 and IPDM E/R harness connector E122 (B) terminal 37.

A		B		Continuity
Connector	Terminal	Connector	Terminal	
E205	4	E122	37	Yes

4. Check continuity between generator harness connector E205 (A) terminal 4 and ground.

A		—	Continuity
Connector	Terminal		
E205	4	Ground	No

Are the continuity test results as specified?

- YES >> Replace IPDM E/R. Refer to [PCS-28. "Removal and Installation of IPDM E/R"](#).
 NO >> Repair harness or connector between IPDM E/R and generator.

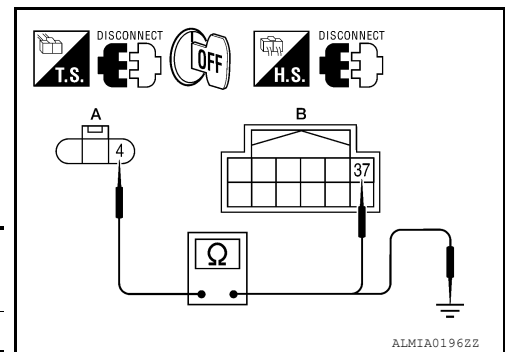

ALMIA0196ZZ

B TERMINAL CIRCUIT

< DTC/CIRCUIT DIAGNOSIS >

B TERMINAL CIRCUIT

Description

INFOID:000000007360882

The terminal "1" (B) circuit supplies power to charge the battery and operate the vehicles electrical system.

Diagnosis Procedure

INFOID:000000007360883

Regarding Wiring Diagram information, refer to [CHG-14, "Wiring Diagram"](#).

1. CHECK TERMINAL "1" CONNECTION

1. Turn ignition switch OFF.
2. Verify terminal "1" is clean and tight.

Is the inspection result normal?

YES >> GO TO 2

NO >> Repair terminal "1" connection. Confirm repair by performing complete Starting/Charging system test. Refer to diagnostic station instruction manual.

2. CHECK TERMINAL "1" CIRCUIT

Check voltage between generator connector E206 terminal 1 and ground.

(+)		(-)	Voltage
Connector	Terminal		
E206	1	Ground	Battery voltage

Is voltage reading as specified?

YES >> GO TO 3.

NO >> Check harness for open between generator and fusible link.

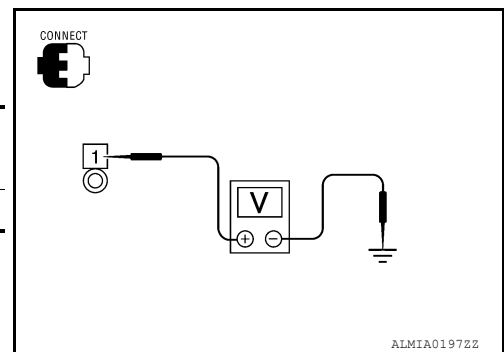

ALMIA01972Z

3. CHECK TERMINAL "1" CONNECTION (VOLTAGE DROP TEST)

1. Start engine, then engine running at idle and warm.
2. Check voltage between battery positive terminal and generator connector E206 terminal 1.

(+)		(-)	Voltage
Connector	Terminal		
E206	1	Battery positive terminal	Less than 0.2V

Is the voltage reading as specified?

YES >> Terminal "1" circuit is normal. Refer to [CHG-5, "Work Flow"](#).

NO >> Check harness between battery and generator for high resistance.

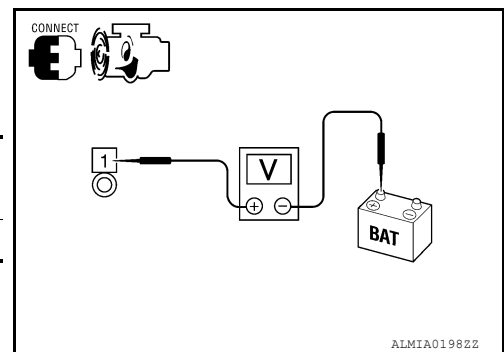

ALMIA01982Z

L TERMINAL CIRCUIT

< DTC/CIRCUIT DIAGNOSIS >

L TERMINAL CIRCUIT

Description

INFOID:000000007360884

The terminal "2" (L) circuit controls the charge warning lamp. The charge warning lamp illuminates when the ignition switch is set to ON or START. When the generator is providing sufficient voltage with the engine running, the charge warning lamp will go off. If the charge warning lamp illuminates with the engine running, a malfunction is indicated.

Diagnosis Procedure

INFOID:000000007360885

Regarding Wiring Diagram information, refer to [CHG-14, "Wiring Diagram"](#).

1. CHECK CHARGE WARNING LAMP CIRCUIT CONNECTION

Verify generator connector E205 terminal 2 is clean and tight.

Is the inspection result normal?

YES >> GO TO 2

NO >> Repair the connection. Confirm repair by performing complete Starting/Charging system test. Refer to diagnostic station instruction manual.

2. CHECK CHARGE WARNING LAMP CIRCUIT

1. Disconnect generator connector E205.
2. Apply ground to generator harness connector E205 terminal 2 with the ignition switch in the ON position.

Charge lamp should illuminate

Does the charge lamp illuminate?

YES >> Check generator function. Refer to [CHG-5, "Work Flow"](#).

NO >> GO TO 3

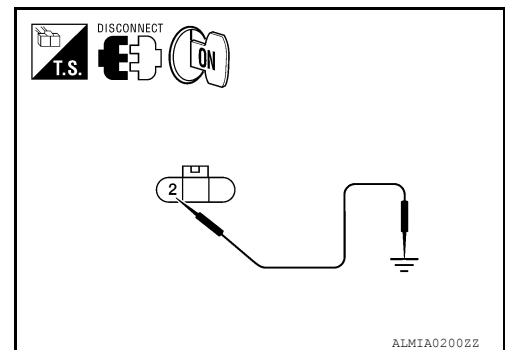

3. CHECK HARNESS CONTINUITY

1. Turn ignition switch OFF.
2. Disconnect the combination meter connector M24.
3. Check continuity between generator harness connector E205 (A) terminal 2 and combination meter harness connector M24 (B) terminal 2.

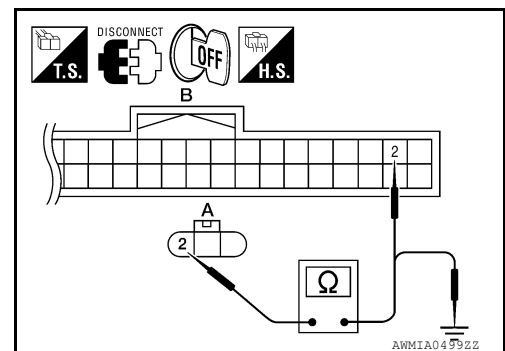

Terminal		Terminal		Continuity
Connector	Terminal	Connector	Terminal	
E205	2	M24	2	Yes

4. Check continuity between generator harness connector E205 (A) terminal 2 and ground.

Terminal		—	Continuity
Connector	Terminal		
E205	2	Ground	No

Are the continuity results as specified?

YES >> Replace the combination meter. Refer to [MWI-83, "Removal and Installation"](#).

NO >> Repair harness or connector.

S TERMINAL CIRCUIT

< DTC/CIRCUIT DIAGNOSIS >

S TERMINAL CIRCUIT

Description

INFOID:000000007360886

The output voltage of the generator is controlled by the IC regulator at terminal "3" (S) detecting the input voltage. Terminal "3" circuit detects the battery voltage to adjust the generator output voltage with the IC regulator.

Diagnosis Procedure

INFOID:000000007360887

Regarding Wiring Diagram information, refer to [CHG-14, "Wiring Diagram"](#).

1. CHECK VOLTAGE REGULATOR CIRCUIT CONNECTION

Check to see if connector E205 terminal 3 is clean and tight.

Is the inspection result normal?

YES >> GO TO 2

NO >> Repair terminal connection. Confirm repair by performing complete Starting/Charging system test.
Refer to diagnostic station instruction manual.

2. CHECK VOLTAGE REGULATOR CIRCUIT

Check voltage between generator harness connector E205 terminal 3 and ground.

3 - ground

Battery voltage

Does battery voltage exist?

YES >> Refer to [CHG-5, "Work Flow"](#).

NO >> Check harness for open between generator and fuse.

A
B
C
D
E
F
G
H
I
J
K
L
N
O
P

CHG

CHARGING SYSTEM

< WIRING DIAGRAM >

WIRING DIAGRAM

CHARGING SYSTEM

Wiring Diagram

INFOID:000000007360888

A : WITH A/T
M : WITH M/T

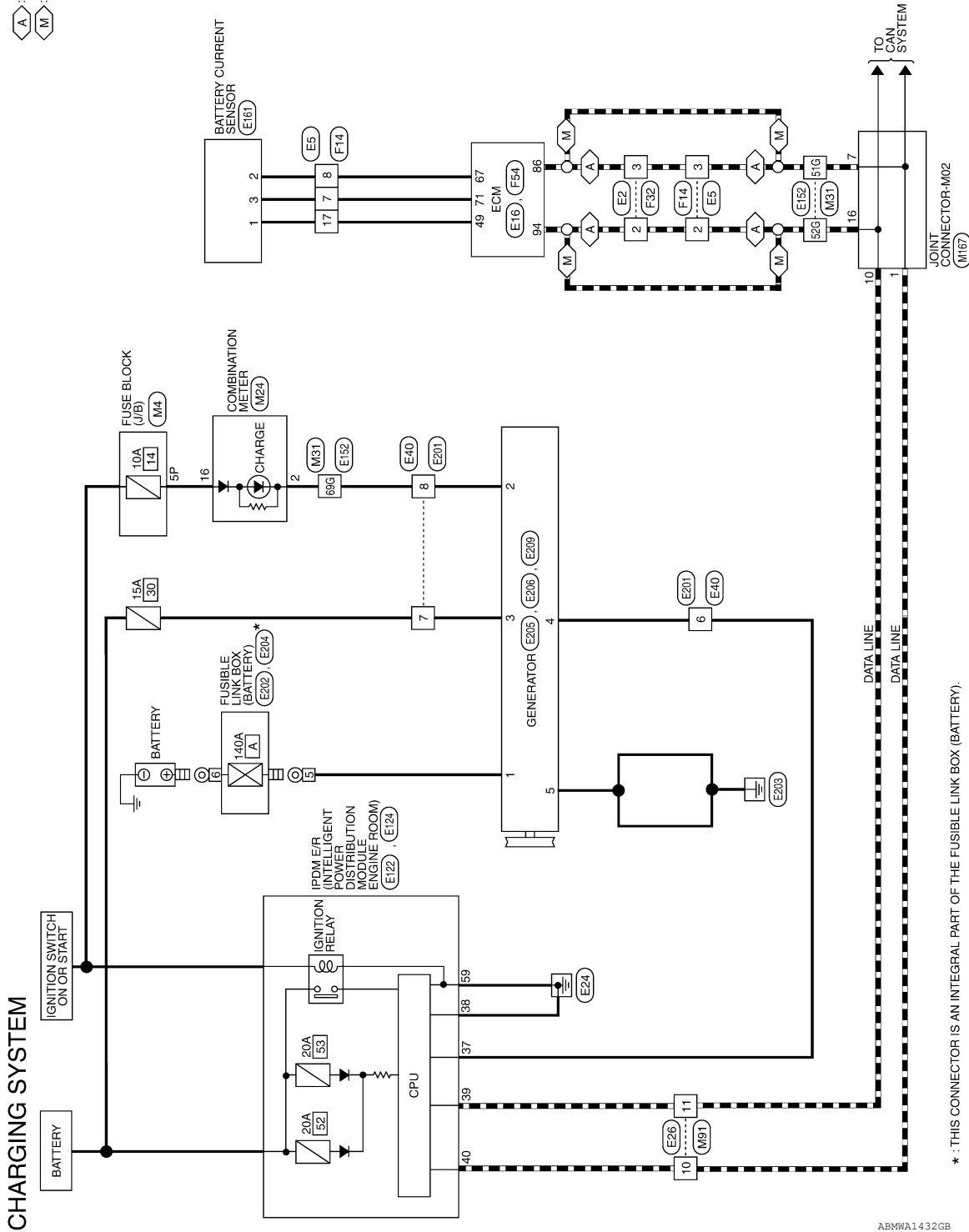

* : THIS CONNECTOR IS AN INTEGRAL PART OF THE FUSIBLE LINK BOX (BATTERY).

ABMWA1432GB

CHARGING SYSTEM CONNECTORS

Connector No.	M4
Connector Name	FUSE BLOCK (J/B)
Connector Color	WHITE



Terminal No.	Color of Wire	Signal Name
5P	W/G	-

Connector No.	M24
Connector Name	COMBINATION METER
Connector Color	WHITE

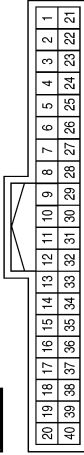

Terminal No.	Color of Wire	Signal Name
2	P	CHARGE (ALT) INPUT
16	W/G	RUN START

Connector No.	M31
Connector Name	WIRE TO WIRE
Connector Color	WHITE

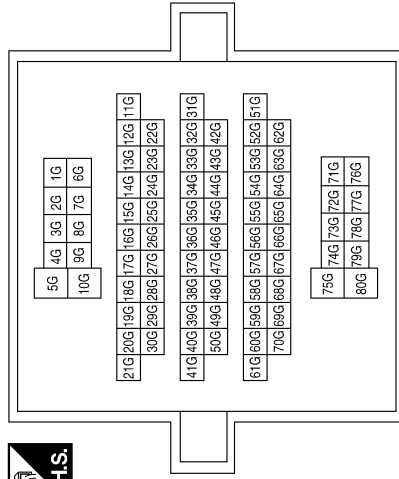

Terminal No.	Color of Wire	Signal Name
51G	P	-
52G	L	-
69G	P	-

Connector No.	M91
Connector Name	WIRE TO WIRE
Connector Color	WHITE

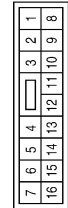

Terminal No.	Color of Wire	Signal Name
10	P	-
11	L	-

Connector No.	M167
Connector Name	JOINT CONNECTOR-M02
Connector Color	BLUE

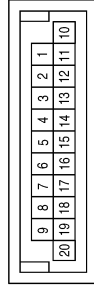

Terminal No.	Color of Wire	Signal Name
1	P	-
7	P	-
10	L	-
16	L	-

Connector No.	E2
Connector Name	WIRE TO WIRE
Connector Color	WHITE

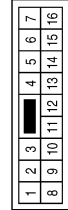

Terminal No.	Color of Wire	Signal Name
2	L	-
3	P	-

ABMIA3495GB

A B C D E F G H I J K L N O P

CHG

CHARGING SYSTEM

< WIRING DIAGRAM >

Connector No.	E5
Connector Name	WIRE TO WIRE
Connector Color	WHITE

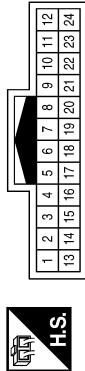

Terminal No.	Color of Wire	Signal Name
2	L	-
3	P	-
7	R	-
8	B	-
17	P	-

Connector No.	E16
Connector Name	ECM
Connector Color	BLACK

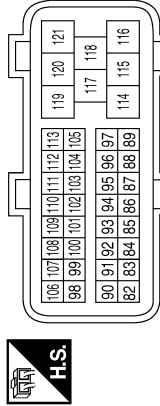

Terminal No.	Color of Wire	Signal Name
86	P	CAN-L
94	L	CAN-H

Connector No.	E26
Connector Name	WIRE TO WIRE
Connector Color	WHITE

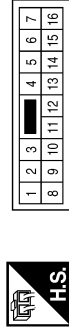

Terminal No.	Color of Wire	Signal Name
10	P	-
11	L	-

Connector No.	E40
Connector Name	WIRE TO WIRE
Connector Color	GRAY

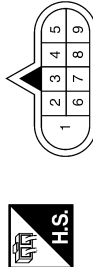

Terminal No.	Color of Wire	Signal Name
6	Y	-
7	SB	-
8	P	-

Connector No.	E122
Connector Name	IPDM E/R (INTELLIGENT POWER DISTRIBUTION MODULE ENGINE ROOM)
Connector Color	WHITE

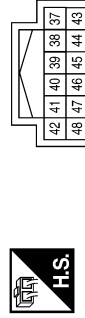

Terminal No.	Color of Wire	Signal Name
37	Y	ALT-C CONT
38	B	GND (SIGNAL)
39	L	CAN-H
40	P	CAN-L

Connector No.	E124
Connector Name	IPDM E/R (INTELLIGENT POWER DISTRIBUTION MODULE ENGINE ROOM)
Connector Color	BLACK



Terminal No.	Color of Wire	Signal Name
59	B	GND (POWER)

CHARGING SYSTEM

< WIRING DIAGRAM >

Connector No.	E161
Connector Name	BATTERY CURRENT SENSOR
Connector Color	BLACK



Terminal No.	Color of Wire	Signal Name
1	P	POWER SUPPLY
2	B	GND
3	R	SIGNAL

Terminal No.	Color of Wire	Signal Name
51G	P	-
52G	L	-
69G	P	-

Connector No.	E152
Connector Name	WIRE TO WIRE
Connector Color	WHITE

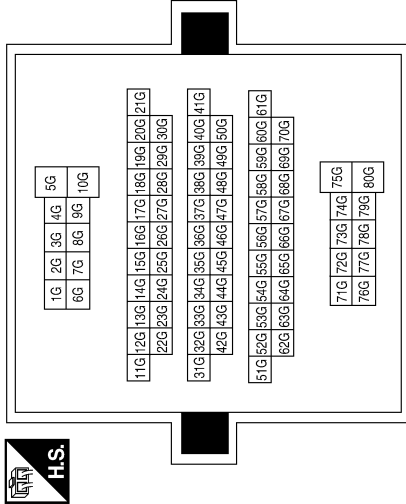

Connector No.	E204
Connector Name	FUSIBLE BOX (BATTERY)
Connector Color	-



Terminal No.	Color of Wire	Signal Name
6	B/R	-

Connector No.	E202
Connector Name	FUSIBLE LINK BOX (BATTERY)
Connector Color	-



Terminal No.	Color of Wire	Signal Name
5	B/R	-

Connector No.	E201
Connector Name	WIRE TO WIRE
Connector Color	GRAY

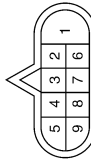

Terminal No.	Color of Wire	Signal Name
6	Y	-
7	SB	-
8	P	-

ABMIA3497GB

A B C D E F G H I J K L N O P

CHG

CHARGING SYSTEM

< WIRING DIAGRAM >

Connector No.	E205
Connector Name	GENERATOR
Connector Color	BLACK



Terminal No.	Color of Wire	Signal Name
2	P	L
3	SB	S
4	Y	C

Connector No.	E206
Connector Name	GENERATOR
Connector Color	-



Terminal No.	Color of Wire	Signal Name
1	B/R	B

Connector No.	E209
Connector Name	GENERATOR
Connector Color	-



Terminal No.	Color of Wire	Signal Name
5	B	E

Connector No.	F14
Connector Name	WIRE TO WIRE
Connector Color	WHITE

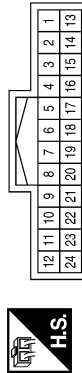

Terminal No.	Color of Wire	Signal Name
2	L	-
3	P	-
7	R	-
8	B	-
17	P	-

Connector No.	F32
Connector Name	WIRE TO WIRE
Connector Color	WHITE

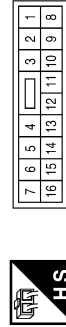

Terminal No.	Color of Wire	Signal Name
2	L	-
3	P	-

Connector No.	F54
Connector Name	ECM
Connector Color	BLACK



Terminal No.	Color of Wire	Signal Name
49	P	AVCC (PDPRES)
67	B	GND-A
71	R	CURSEN

CHARGING SYSTEM

< SYMPTOM DIAGNOSIS >

SYMPTOM DIAGNOSIS

CHARGING SYSTEM

Symptom Table

INFOID:000000007360889

Symptom	Reference
Battery discharged	Refer to CHG-5, "Work Flow" .
The charge warning lamp does not illuminate when the ignition switch is set to ON.	
The charge warning lamp does not turn OFF after the engine starts.	
The charging warning lamp turns ON when increasing the engine speed.	

A

B

C

D

E

F

G

H

I

J

K

L

CHG

N

O

P

GENERATOR

< REMOVAL AND INSTALLATION >

REMOVAL AND INSTALLATION

GENERATOR

Exploded View

INFOID:000000007360890

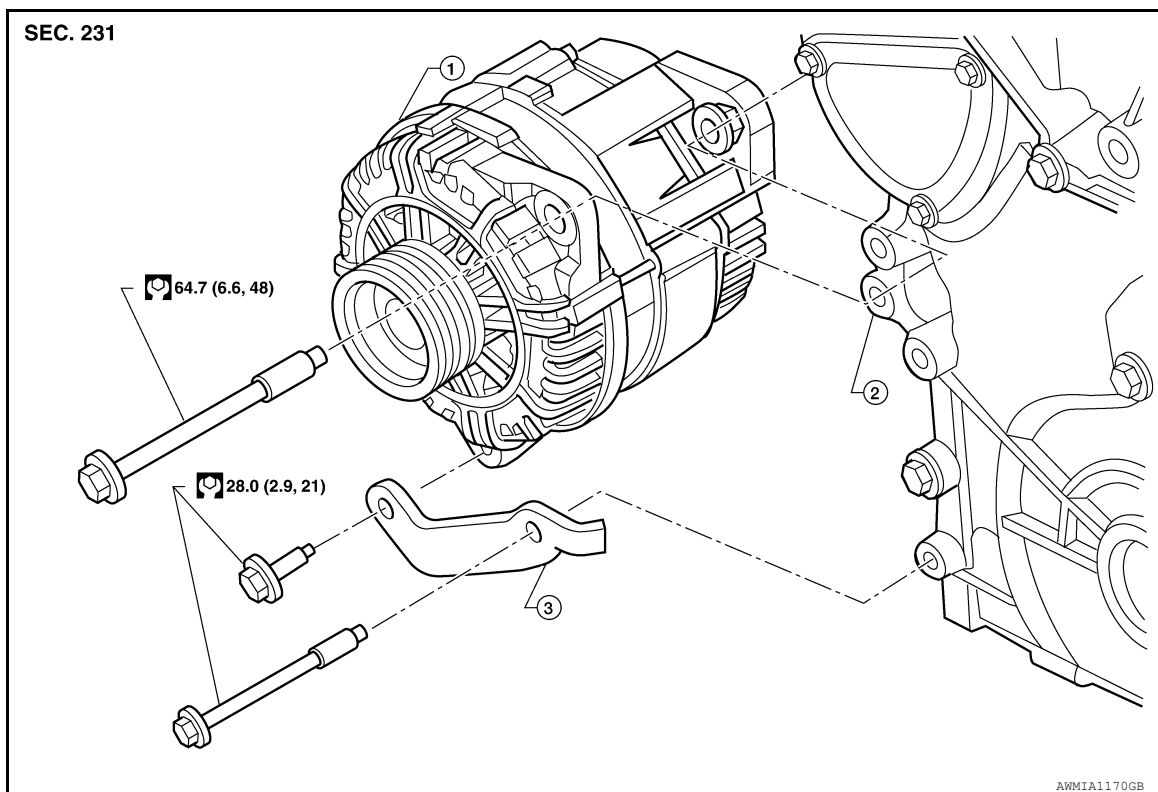

1. Generator

2. Engine block

3. Generator stay

Removal and Installation

INFOID:000000007360891

NOTE:

When removing components such as hoses, tubes/lines, etc., cap or plug openings to prevent fluid from spilling.

REMOVAL

1. Disconnect the negative battery terminal. Refer to [PG-72, "Removal and Installation"](#).
2. Partially drain the engine coolant. Refer to [CO-11, "Changing Engine Coolant"](#).
3. Remove engine room cover.
4. Remove air duct and resonator assembly. Refer to [EM-24, "Exploded View"](#).
5. Remove upper radiator hose.
6. Disconnect coolant reservoir hose from radiator.
7. Remove the crankcase ventilation hose.
8. Remove the fan shroud. Refer to [CO-15, "Exploded View"](#).
9. Remove engine cooling fan (Motor Driven Type). Refer to [CO-19, "Removal and Installation \(Motor driven type\)"](#).
10. Remove the drive belt. Refer to [EM-13, "Removal and Installation"](#).
11. Remove the generator stay, using power tools.
12. Remove the generator upper bolt, using power tools.
13. Disconnect the generator harness connectors.
14. Remove the generator.

GENERATOR

< REMOVAL AND INSTALLATION >

INSTALLATION

Installation is in the reverse order of removal.

- Install the generator and check tension of drive belt. Refer to [EM-13. "Checking Drive Belts"](#).

Terminal nut : 10.8 N·m (1.1 kg-m, 8 ft-lb)

CAUTION:

Tighten terminal nut carefully.

- For this model, the power generation variable voltage control system that controls the power generation voltage of the generator has been adopted. Therefore, the power generation variable voltage control system inspection should be performed after replacing the generator in order to ensure that the system operates normally. Refer to [CHG-9. "Diagnosis Procedure"](#).

A
B
C
D
E
F
G
H
I
J
K
L
N
O
P

CHG

SERVICE DATA AND SPECIFICATIONS (SDS)

< SERVICE DATA AND SPECIFICATIONS (SDS)

SERVICE DATA AND SPECIFICATIONS (SDS)

SERVICE DATA AND SPECIFICATIONS (SDS)

Generator

INFOID:000000007360892

Type*	TG15S179 Valeo
Engine	VQ40DE
Nominal rating	14V-130A
Ground polarity	Negative
Minimum revolution under no-load	1,200 rpm
Hot output current (When 13.5 volts is applied)	More than 52A/1,500 rpm More than 82A/1,800 rpm More than 115A/2,500 rpm More than 130A/5,000 rpm
Regulated output voltage	13.5V @ 5,000 rpm @ 20°C (68°F)
Adjustment range of power generation variable voltage control	11.4 - 15.6V

*: Always check with the Parts Department for the latest parts information