

**SECTION** **ST**  
**STEERING SYSTEM**

A  
 B  
 C  
 D  
 E  
 F  
**ST**  
 H  
 I  
 J  
 K  
 L  
 M  
 N  
 O  
 P

**CONTENTS**

<b>PRECAUTION</b> .....	2	<b>STEERING COLUMN</b> .....	12
<b>PRECAUTIONS</b> .....	2	Removal and Installation .....	12
Precaution for Supplemental Restraint System (SRS) "AIR BAG" and "SEAT BELT PRE-TENSIONER" .....	2	<b>POWER STEERING GEAR AND LINKAGE</b> ....	15
Precaution for Steering System .....	2	Removal and Installation .....	15
<b>PREPARATION</b> .....	3	<b>POWER STEERING OIL PUMP</b> .....	17
<b>PREPARATION</b> .....	3	Component .....	17
Special Service Tool .....	3	Removal and Installation .....	17
Commercial Service Tool .....	4	<b>HYDRAULIC LINE</b> .....	19
<b>SYMPTOM DIAGNOSIS</b> .....	5	Removal and Installation .....	19
<b>NOISE, VIBRATION AND HARSHNESS (NVH) TROUBLESHOOTING</b> .....	5	<b>UNIT DISASSEMBLY AND ASSEMBLY</b> ...	21
NVH Troubleshooting Chart .....	5	<b>STEERING COLUMN</b> .....	21
<b>PERIODIC MAINTENANCE</b> .....	6	Disassembly and Assembly .....	21
<b>POWER STEERING FLUID</b> .....	6	<b>POWER STEERING OIL PUMP</b> .....	23
Checking Fluid Level .....	6	Disassembly and Assembly .....	23
Checking Fluid Leakage .....	6	<b>STEERING GEAR AND LINKAGE</b> .....	25
Air Bleeding Hydraulic System .....	6	Disassembly and Assembly .....	25
<b>STEERING WHEEL</b> .....	8	<b>SERVICE DATA AND SPECIFICATIONS (SDS)</b> .....	28
On-Vehicle Inspection and Service .....	8	<b>SERVICE DATA AND SPECIFICATIONS (SDS)</b> .....	28
<b>POWER STEERING OIL PUMP</b> .....	10	Steering Wheel .....	28
On-Vehicle Inspection and Service .....	10	Steering Column .....	28
<b>REMOVAL AND INSTALLATION</b> .....	11	Tie-rod .....	28
<b>STEERING WHEEL</b> .....	11	Steering Gear .....	29
Removal and Installation .....	11	Oil Pump .....	29
		Steering Fluid .....	29

# PRECAUTIONS

< PRECAUTION >

## PRECAUTION

### PRECAUTIONS

#### Precaution for Supplemental Restraint System (SRS) "AIR BAG" and "SEAT BELT PRE-TENSIONER"

INFOID:000000007359997

The Supplemental Restraint System such as "AIR BAG" and "SEAT BELT PRE-TENSIONER", used along with a front seat belt, helps to reduce the risk or severity of injury to the driver and front passenger for certain types of collision. This system includes seat belt switch inputs and dual stage front air bag modules. The SRS system uses the seat belt switches to determine the front air bag deployment, and may only deploy one front air bag, depending on the severity of a collision and whether the front occupants are belted or unbelted. Information necessary to service the system safely is included in the SR and SB section of this Service Manual.

#### **WARNING:**

- **To avoid rendering the SRS inoperative, which could increase the risk of personal injury or death in the event of a collision which would result in air bag inflation, all maintenance must be performed by an authorized NISSAN/INFINITI dealer.**
- **Improper maintenance, including incorrect removal and installation of the SRS, can lead to personal injury caused by unintentional activation of the system. For removal of Spiral Cable and Air Bag Module, see the SR section.**
- **Do not use electrical test equipment on any circuit related to the SRS unless instructed to in this Service Manual. SRS wiring harnesses can be identified by yellow and/or orange harnesses or harness connectors.**

#### PRECAUTIONS WHEN USING POWER TOOLS (AIR OR ELECTRIC) AND HAMMERS

#### **WARNING:**

- **When working near the Airbag Diagnosis Sensor Unit or other Airbag System sensors with the Ignition ON or engine running, DO NOT use air or electric power tools or strike near the sensor(s) with a hammer. Heavy vibration could activate the sensor(s) and deploy the air bag(s), possibly causing serious injury.**
- **When using air or electric power tools or hammers, always switch the Ignition OFF, disconnect the battery, and wait at least 3 minutes before performing any service.**

#### Precaution for Steering System

INFOID:000000007359998

- Before disassembly, thoroughly clean the outside of the unit.
- Disassembly should be done in a clean work area. It is important to prevent the internal parts from becoming contaminated by dirt or other foreign matter.
- For easier and proper assembly, place disassembled parts in order on a parts rack.
- Use nylon cloth or paper towels to clean the parts; common shop rags can leave lint that might interfere with their operation.
- Before inspection or reassembly, carefully clean all parts with a general purpose, non-flammable solvent.
- Before assembly, apply a coat of recommended Genuine NISSAN PSF or equivalent to hydraulic parts. Petroleum jelly may be applied to O-rings and seals. Do not use any grease.
- Replace all gaskets, seals and O-rings. Avoid damaging O-rings, seals and gaskets during installation. Perform functional tests whenever designated.

# PREPARATION

< PREPARATION >

## PREPARATION

### PREPARATION

#### Special Service Tool

INFOID:000000007359999

The actual shapes of Kent-Moore tools may differ from those of special service tools illustrated here.

Tool number (Kent-Moore No.) Tool name	Description
ST3127 S000 (See J-25765-A) Preload gauge 1. GG9103000 (J-25765-A) Torque wrench 2. HT62940000 ( — ) Socket adapter 3. HT62900000 ( — ) Socket adapter	Inspecting of pinion rotating torque and rotational torque for ball joint
HT72520000 (J-25730-A) Ball joint remover	Removing steering outer socket
1. KV48105300-4 and 5295262U10 ( — ) Connector A and O-ring 2. KV48105300-3 and 5295262U00 ( — ) Eye-bolt and O-ring 3. KV48103500 (J-26357 and J-26357-10) Pressure gauge and shut-off valve 4. KV48105300-1 and 5295262U00 ( — ) Connector B and O-ring 5. KV48105300-2 ( — ) Nut	Measuring oil pump relief pressure
— (J-44372) Spring gauge	Measuring steering wheel turning force
KV40107300 ( — ) Crimping pliers	Crimping boot bands

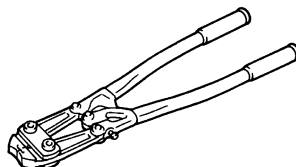
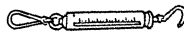
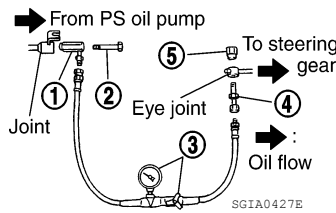
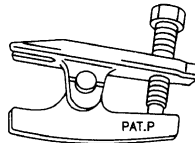
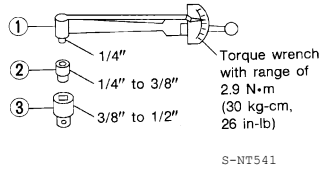

A  
B  
C  
D  
E  
F  
ST  
H  
I  
J  
K  
L  
M  
N  
O  
P

# PREPARATION

## < PREPARATION >

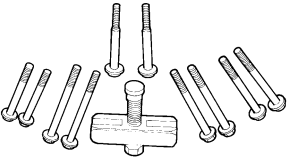
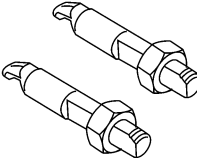
Tool number (Kent-Moore No.) Tool name	Description
KV481J0010 (J-1859A) Steering wheel puller   LHIA0043E	Removing steering wheel
KV481J0020 (J-42578) Steering wheel puller legs   LHIA0044E	Removing steering wheel

## Commercial Service Tool

INFOID:000000007360000

Kent-Moore No. Tool name	Description
Power tool   PIIB1407E	Loosening bolts, nuts and screws

# NOISE, VIBRATION AND HARSHNESS (NVH) TROUBLESHOOTING

< SYMPTOM DIAGNOSIS >

## SYMPTOM DIAGNOSIS

### NOISE, VIBRATION AND HARSHNESS (NVH) TROUBLESHOOTING

#### NVH Troubleshooting Chart

INFOID:000000007360001

Use chart below to help you find the cause of the symptom. If necessary, repair or replace these parts.

Symptom	Possible cause and suspected parts													Reference page											
	Fluid level	Air in hydraulic system	Outer socket ball joint swinging force	Outer socket ball joint rotating torque	Outer socket ball joint end play	Steering fluid leakage	Steering wheel play	Steering gear rack sliding force	Drive belt looseness	Improper steering wheel	Improper installation or looseness of tilt lock lever	Mounting rubber deterioration	Steering column deformation or damage		Improper installation or looseness of steering column	Steering linkage looseness	PROPELLER SHAFT	FRONT FINAL DRIVE	AXLE	SUSPENSION	TIRES	ROAD WHEEL	DRIVE SHAFT	BRAKES	
Noise	x	x	x	x	x	x	x	x	x							x	x	x	x	x	x	x	x	x	SI-6
Shake										x	x	x				x		x	x	x	x				SI-6
Vibration										x	x	x	x	x		x		x	x	x					SI-29
Shimmy										x	x	x			x			x	x	x	x				SI-29
Shudder												x		x	x			x	x	x	x				SI-6
																									SI-8
																									SI-8
																									EM-13, "Checking Drive Belts"
																									SI-8
																									SI-12
																									SI-15
																									SI-12
																									SI-12
																									SI-15
																									DLN-132, "NVH Troubleshooting Chart"
																									DLN-161, "NVH Troubleshooting Chart"
																									FAX-4, "NVH Troubleshooting Chart"
																									FAX-4, "NVH Troubleshooting Chart"
																									WT-43, "NVH Troubleshooting Chart"
																									WT-43, "NVH Troubleshooting Chart"
																									FAX-4, "NVH Troubleshooting Chart"
																									BR-5, "NVH Troubleshooting Chart"

x: Applicable

A  
B  
C  
D  
E  
F  
ST  
H  
I  
J  
K  
L  
M  
N  
O  
P

# POWER STEERING FLUID

< PERIODIC MAINTENANCE >

## PERIODIC MAINTENANCE

### POWER STEERING FLUID

#### Checking Fluid Level

INFOID:000000007360002

Check fluid level, referring to the scale on the reservoir tank.  
Use HOT range for fluid temperatures of 50° – 80°C (122° – 176°F).  
Use COLD range for fluid temperatures of 0° – 30°C (32° – 86°F).

**CAUTION:**

- Do not overfill.
- Do not reuse any power steering fluid.
- Recommended fluid is Genuine NISSAN PSF or equivalent. Refer to [MA-13, "Fluids and Lubricants"](#).

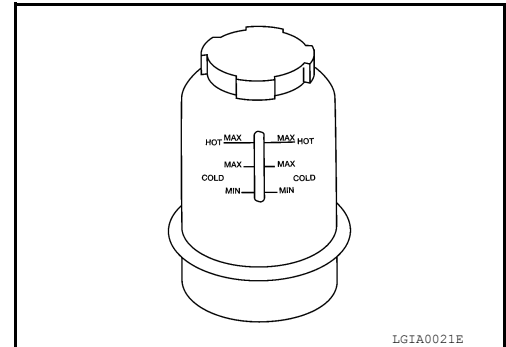

#### Checking Fluid Leakage

INFOID:000000007360003

Check the hydraulic piping lines for improper attachment, leaks, cracks, damage, loose connections, chafing and deterioration.

1. Run the engine until the fluid temperature reaches 50°– 80°C (122°– 176°F) in the reservoir tank. Keep engine speed idle.

**CAUTION:**

**Do not allow steering fluid reservoir tank to go below the MIN level line. Check tank frequently and add fluid as needed.**

2. Turn the steering wheel to the right and left several times.
3. Hold the steering wheel at each "locked" position for five seconds to check for fluid leakage.

**CAUTION:**

**Do not hold steering wheel in the locked position for more than 10 seconds. (There is the possibility that the oil pump may be damaged.)**

4. If fluid leakage at a connection is noticed, loosen the connection and then retighten. Do not over-tighten connector as this can damage O-ring, washer and connector. Refer to [ST-10](#) and [ST-19](#).
5. If fluid leakage from the oil pump is noticed, repair or replace the oil pump. Refer to [ST-23, "Disassembly and Assembly"](#).
6. Check steering gear boots for accumulation of fluid, indicating a leak from the steering gear.

**CAUTION:**

**Do not reuse copper sealing washers.**

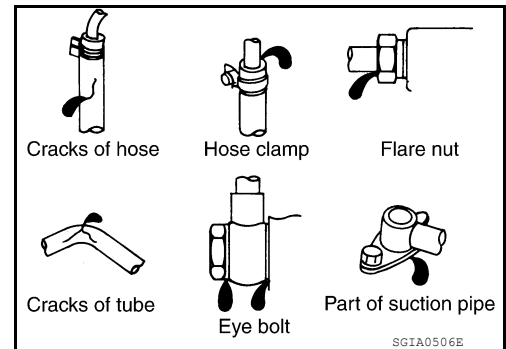

#### Air Bleeding Hydraulic System

INFOID:000000007360004

Incomplete air bleeding causes the following:

- Air bubbles in reservoir tank
- Clicking noise in oil pump
- Excessive buzzing in oil pump

When this happens bleed the air again.

1. With the engine not started, turn steering wheel fully right to left several times. When fluid level is lowered, refill reservoir. Repeat process until fluid level is stabilized.
2. Start the engine and turn the steering wheel fully to the right and left several times.

**CAUTION:**

**Do not allow steering fluid reservoir tank to go below the MIN level line. Check tank frequently and add fluid as needed.**

**NOTE:**

When the vehicle is stationary or while the steering wheel is being turned slowly, some noise may be heard from the oil pump or gear. This noise is normal and does not affect any system.

## POWER STEERING FLUID

### < PERIODIC MAINTENANCE >

---

3. Run the engine at idle speed. Hold the steering wheel at each "locked" position for three seconds.  
**CAUTION:**  
**Do not hold steering wheel in the locked position for more than 10 seconds. (There is the possibility that oil pump may be damaged.)**
4. Repeat step 3 several times at about three second intervals.
5. Check for air bubbles, cloudy fluid and fluid leakage.
6. If air bubbles or cloudiness exists, perform steps 3 and 4 again until air bubbles and cloudiness do not exist.
7. Stop the engine and check fluid level.

A

B

C

D

E

F

ST

H

I

J

K

L

M

N

O

P

# STEERING WHEEL

< PERIODIC MAINTENANCE >

## STEERING WHEEL

### On-Vehicle Inspection and Service

INFOID:000000007360005

#### CHECKING CONDITION OF INSTALLATION

- Check the installation condition of the steering gear assembly, front suspension, axle and steering column.
- Check if movement exists when the steering wheel is pushed up and down, left and right and in the axial direction.

**End play of the axle direction for steering wheel** : Refer to [ST-28, "Steering Wheel"](#)

- Check if the nuts for the steering gear assembly are loose. Refer to [ST-15](#).

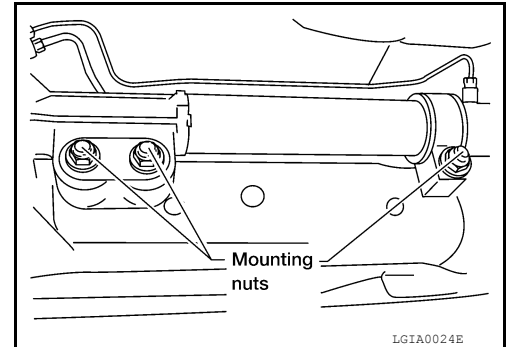

#### CHECKING STEERING WHEEL PLAY

1. Turn the tires straight ahead and start the engine. Lightly turn the steering wheel left and right to the point where the tires start moving, and measure the distance that the outer circumference of the steering wheel travels.

**Steering wheel play on the outer circumference** : Refer to [ST-28, "Steering Wheel"](#)

#### CHECKING NEUTRAL POSITION ON STEERING WHEEL

- Check the neutral position on the steering wheel after confirming the front wheel alignment is correct. Refer to [FSU-6, "Front Wheel Alignment"](#).
1. Turn the tires straight ahead, check if the steering wheel is in the neutral position.
  2. If it is not in the neutral position, remove the steering wheel and reinstall it correctly on the steering stem, within two teeth of the original position.
  3. If the neutral position cannot be attained by repositioning the steering wheel within two teeth on the steering stem, loosen the tie-rod lock nuts of the steering outer sockets, then adjust the tie-rods by the same amount in the opposite direction of the steering wheel.

#### CHECKING STEERING WHEEL TURNING FORCE

1. Park vehicle on a level, dry surface and set parking brake.
2. Start engine.
3. Bring the power steering fluid up to adequate operating temperature. Make sure the fluid temperature is approximately 50° – 80°C (122° – 176°F).
4. Tires need to be inflated to specified pressure. Refer to [WT-51, "Tire"](#).



## STEERING WHEEL

### < PERIODIC MAINTENANCE >

5. Check steering wheel turning force using Tool when steering wheel has been turned 360° from the neutral position.

**Tool number** : — (J-44372)

**Steering wheel turning force** : Refer to [ST-28, "Steering Wheel"](#)

6. If steering wheel turning force is out of specification, inspect the following:
- Steering column. Refer to [ST-12, "Removal and Installation"](#).
  - Power steering oil pump. Refer to [ST-10, "On-Vehicle Inspection and Service"](#).
7. If steering column and power steering oil pump meet specifications, replace steering gear. Refer to [ST-15, "Removal and Installation"](#).

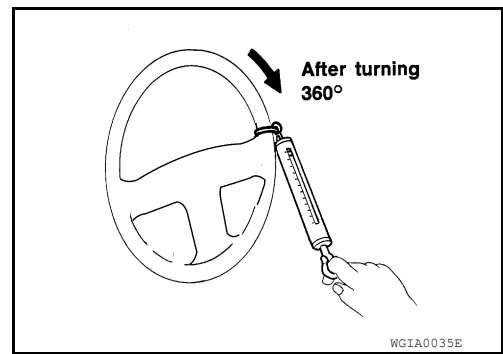

### CHECKING FRONT WHEEL TURNING ANGLE

When checking the front wheel turning angle, refer to [FSU-6, "Front Wheel Alignment"](#).

A  
B  
C  
D  
E  
F  
ST  
H  
I  
J  
K  
L  
M  
N  
O  
P

# POWER STEERING OIL PUMP

< PERIODIC MAINTENANCE >

## POWER STEERING OIL PUMP

### On-Vehicle Inspection and Service

INFOID:000000007360006

#### CHECKING RELIEF OIL PRESSURE

#### CAUTION:

Before starting work, confirm that the belt tension is within specification. Refer to [EM-13, "Adjustment"](#).

1. Connect the Tool between the power steering oil pump discharge connector and the high pressure hose, then bleed the air from the hydraulic circuit with the shut-off valve fully open. Refer to [ST-6, "Air Bleeding Hydraulic System"](#).

Tool number:		
Pressure gauge and shut-off valve		KV48103500 (J-26357 and J-26357-10)
Oil pump side	Connector A and O-ring	KV48105300-4 and 5295262U10 ( — )
	Eye-bolt and O-ring	KV48105300-3 and 5295262U00 ( — )
High pressure piping side	Connector B and O-ring	KV48105300-1 and 5295262U00 ( — )
	Nut	KV48105300-2 ( — )

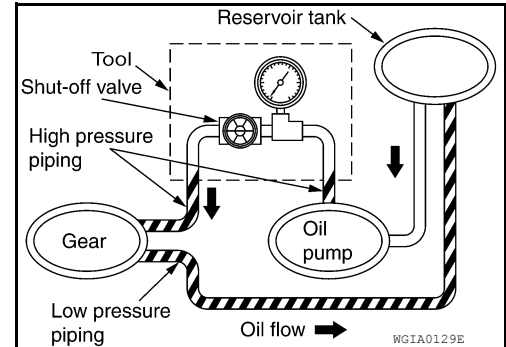

2. Start the engine. Run the engine until the power steering fluid temperature in reservoir tank reaches 50°–80°C (122°– 176°F).

#### CAUTION:

- Warm up the engine with the shut-off valve fully opened. If the engine is started with the shut-off valve closed, fluid pressure in the power steering oil pump increases to maximum pressure. This will raise fluid temperature excessively.
- Do not contact the belt with the hose while the engine is running.

3. With the engine at idle, close the shut-off valve and read the relief oil pressure.

Relief oil pressure : Refer to [ST-29, "Oil Pump"](#)

#### CAUTION:

Do not close the shut-off valve of the pressure gauge for more than 10 seconds.

4. After measurement, open the shut-off valve slowly.
  - If relief oil pressure is outside the specification, replace the power steering oil pump. Refer to [ST-17, "Removal and Installation"](#).
5. After inspection, disconnect the oil pressure gauge and oil pressure gauge adapter from the hydraulic circuit, then connect the power steering oil pump discharge connector. Add fluid and bleed the air from the hydraulic circuit thoroughly. Refer to [ST-6, "Air Bleeding Hydraulic System"](#).

# STEERING WHEEL

< REMOVAL AND INSTALLATION >

## REMOVAL AND INSTALLATION

### STEERING WHEEL

#### Removal and Installation

INFOID:000000007360007

#### REMOVAL

1. Set the front wheels in the straight-ahead position.
2. Remove the driver air bag module. Refer to [SR-4, "Removal and Installation"](#).
3. Disconnect the steering wheel switches.
4. Remove the steering wheel center nut.
5. Remove the steering wheel, using Tools.

**Tool number**    **A: KV481J0010 (J-1859A)**  
                          **B: KV481J0020 (J-42578)**

6. Inspect the steering wheel near the puller holes for damage. If damage is found, replace the steering wheel.
  - Remove the steering wheel rear cover and steering wheel switches, if required.

**CAUTION:**

**Place a piece of tape across the spiral cable so it will not be rotated out of position.**

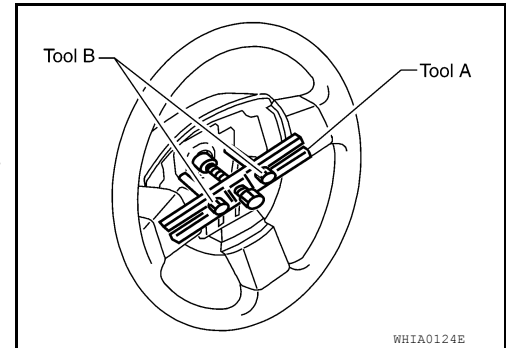

#### INSTALLATION

Installation is in the reverse order of removal.

- Align spiral cable correctly when installing steering wheel. Make sure that the spiral cable is in the neutral position. The neutral position is detected by turning left 2.5 revolutions from the right end position and ending with the locating pin at the top.
- After installation, perform the steering angle sensor adjustment. Refer to [BRC-12, "ADJUSTMENT OF STEERING ANGLE SENSOR NEUTRAL POSITION : Special Repair Requirement"](#) (TYPE 1), [BRC-122, "ADJUSTMENT OF STEERING ANGLE SENSOR NEUTRAL POSITION : Special Repair Requirement"](#) (TYPE 2) for steering angle sensor adjustment.
- After the work is completed, perform self-diagnosis to make sure no malfunction is detected. Refer to [SRC-13, "SRS Operation Check"](#).
- Tighten steering wheel center nut to specification. Refer to [ST-11, "Removal and Installation"](#).

**CAUTION:**

- The spiral cable may snap due to steering operation if the cable is not installed in the correct position.
- With the steering linkage disconnected, the cable may snap by turning the steering wheel beyond the limited number of turns. The spiral cable can be turned counterclockwise about 2.5 turns from the neutral position.

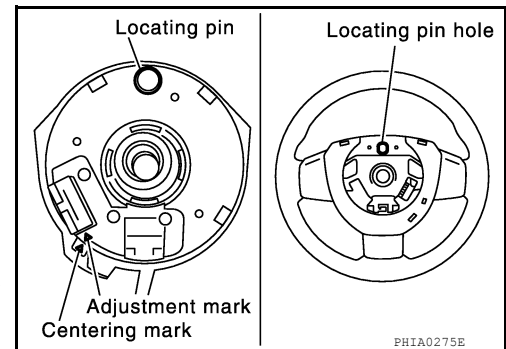

# STEERING COLUMN

< REMOVAL AND INSTALLATION >

## STEERING COLUMN

### Removal and Installation

INFOID:000000007360008

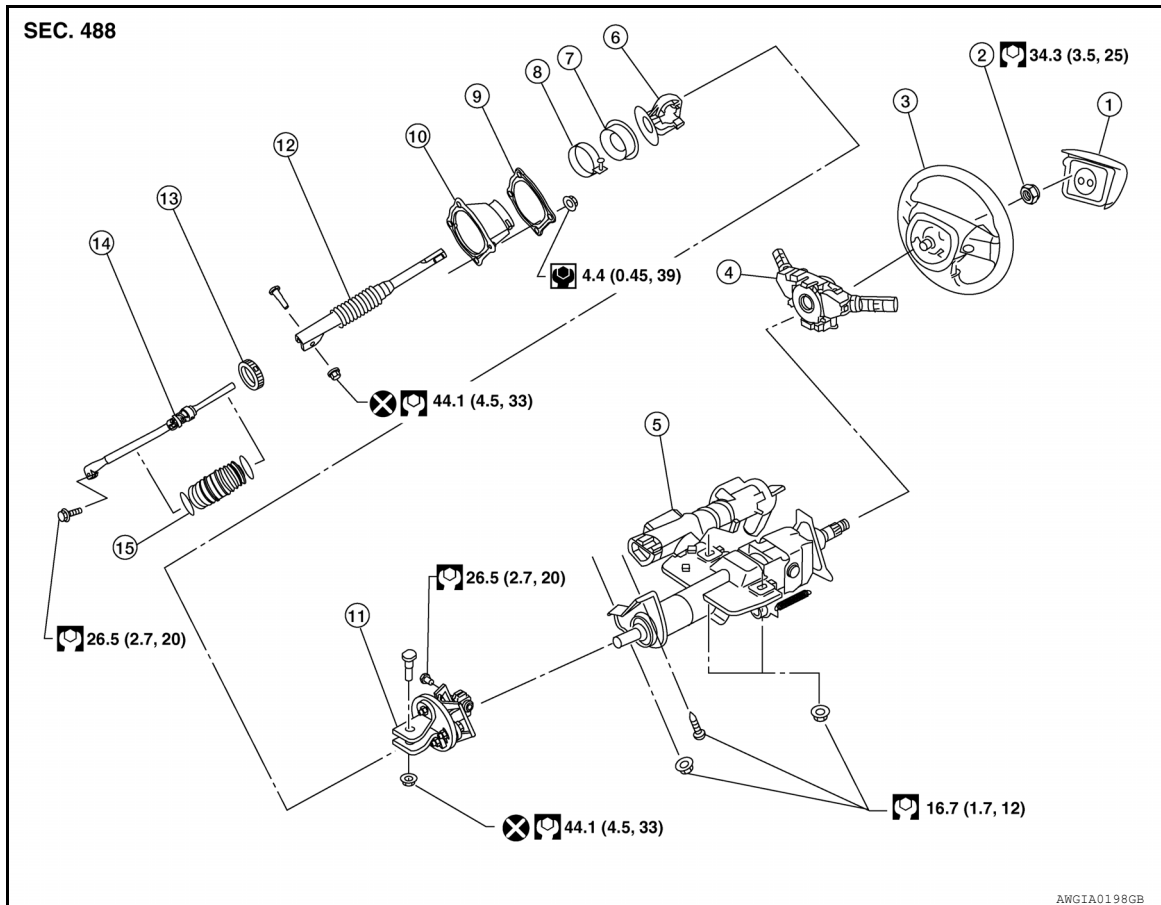

- |  |   |                              |
|--|---|------------------------------|
| 1. Driver air bag module               | 2. Steering wheel center nut                    | 3. Steering wheel            |
| 4. Combination switch and spiral cable | 5. Steering column assembly and ignition switch | 6. Collar                    |
| 7. Hole cover seal                     | 8. Clamp  | 9. Hole cover mounting plate |
| 10. Hole cover                         | 11. Upper joint                                 | 12. Upper shaft              |
| 13. Boot clamp                         | 14. Lower joint shaft                           | 15. Boot and clips (plastic) |

### CAUTION:

- Do not exert any axial load or impact to the steering column.
- Do not move the steering gear while the steering column assembly is removed.
- Anytime the ignition switch has been removed or installed, the keys must be re-registered in the BCM. Refer to **CONSULT** operation manual IVIS/NVIS.

### REMOVAL

1. Remove the spiral cable with the combination switches attached from the steering column assembly. Refer to [SR-6, "Removal and Installation"](#).
2. Remove the instrument lower panel LH. Refer to [IP-10, "Exploded View"](#).
3. Remove the key interlock cable from the steering column (if equipped). Refer to [TM-241, "Removal and Installation"](#).

# STEERING COLUMN

## < REMOVAL AND INSTALLATION >

4. Remove the lock nut and bolt from the upper joint, then separate the upper joint from the upper shaft.

**CAUTION:**

- Do not reuse the lock nut.

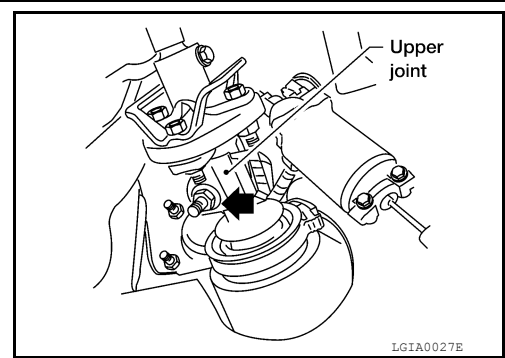

5. Remove the three nuts and bolt from the steering column assembly, then remove the steering column assembly from the steering member.
6. Remove the hole cover seal and clamp.
7. Remove the hole cover nuts, then remove the hole cover from the dash panel.

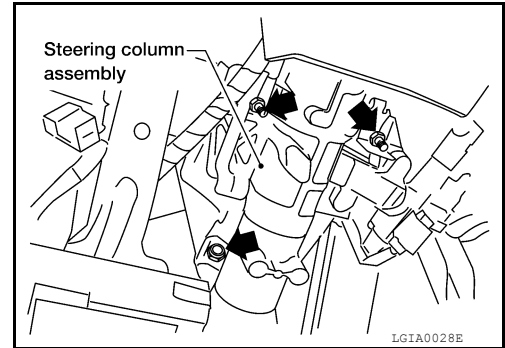

8. Remove the bolt from the lower joint of the lower joint shaft, then remove the lower joint shaft from the vehicle.

**CAUTION:**

- Do not damage the lower joint.

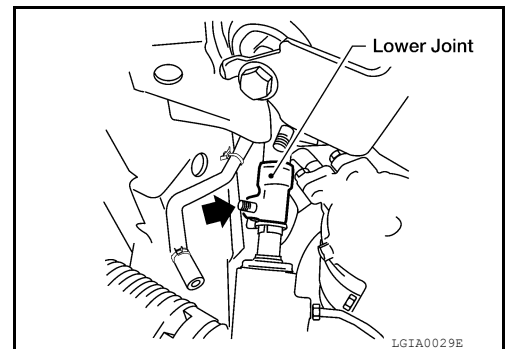

## INSPECTION AFTER REMOVAL

- Check for damage to the steering column jacket tube. If damage is found, replace the steering column with a new one.

**CAUTION:**

- Do not exert any axial load or impact to the steering column.
- Replace the column if it is depleted of grease, worn, damaged, or if any scratches or coating separation is present on the shaft seal area.
- If the vehicle has been in a collision, or if noises are heard coming from the steering column, check column length. If out of specification, replace the steering column as an assembly.

**Steering column length (L) : Refer to [ST-28, "Steering Column"](#).**

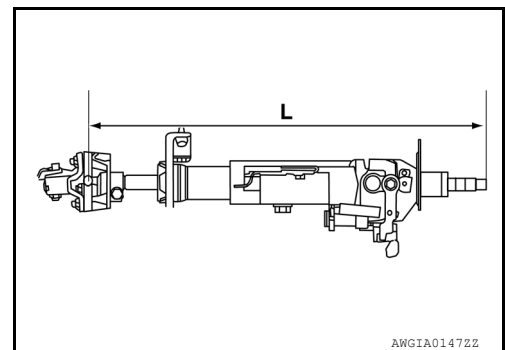

## INSTALLATION

Installation is in the reverse order of removal.

**CAUTION:**

# STEERING COLUMN

## < REMOVAL AND INSTALLATION >

**When installing the steering column, finger-tighten all of the lower bracket and joint bolts; then tighten them to specification. Do not apply undue stress to the steering column.**

### NOTE:

- With the wheels in the straight ahead position, align the slit of the lower joint with the projection on the dust cover. Insert the joint until surface (A) contacts surface (B).
- After installation, inspect the steering column for proper operation.

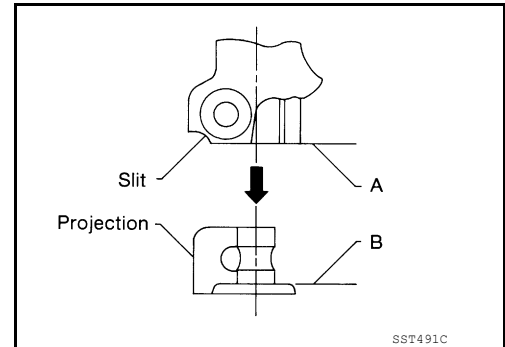

## INSPECTION AFTER INSTALLATION

- Check the tilt device for proper tilt range.

**Tilt range (A) : Refer to [ST-28, "Steering Column"](#).**

- Check that the steering wheel turns smoothly to the left and right locks.
- Check that the number of turns are the same from the straight-forward position to the left and right locks.
- Check that the steering wheel is in the neutral position when driving straight ahead.

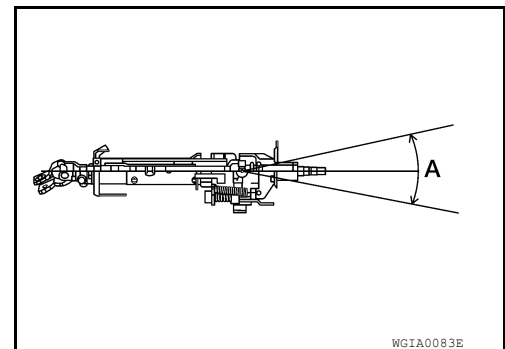

# POWER STEERING GEAR AND LINKAGE

< REMOVAL AND INSTALLATION >

## POWER STEERING GEAR AND LINKAGE

### Removal and Installation

INFOID:000000007360009

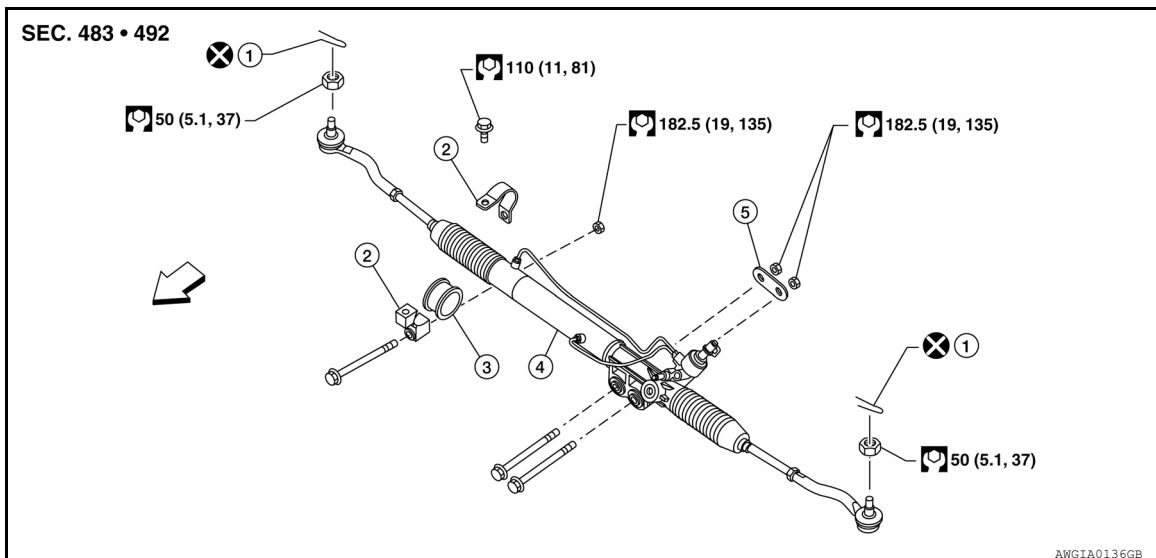

- |                           |                     |                       |
|---------------------------|---------------------|-----------------------|
| 1. Cotter pin             | 2. Mounting bracket | 3. Mounting insulator |
| 4. Steering gear assembly | 5. Washer           | ← Front               |

#### CAUTION:

Spiral cable may snap due to steering operation if the steering column is separated from the steering gear assembly. Therefore secure the steering wheel to avoid turning.

#### NOTE:

When removing components such as hoses, tubes/lines, etc., cap or plug openings to prevent fluid from spilling.

#### REMOVAL

1. Set front wheels in the straight-ahead position.
2. Remove the front tires from the vehicle, using power tool.
3. Drain power steering fluid.
4. Remove the under cover, using power tool.
5. On 4WD models, remove the front final drive, then support the drive shafts, using suitable wire. Refer to [DLN-168, "Removal and Installation"](#).
6. Remove the stabilizer bar brackets and reposition the stabilizer bar. Refer to [FSU-15, "Removal and Installation"](#).
7. Remove the cotter pins at the steering outer sockets.  
**CAUTION:**  
**Do not reuse the cotter pins.**
8. Loosen the outer socket nuts.
9. Remove the steering outer sockets from the steering knuckles, using Tool, then remove the nuts.

**Tool number** : HT72520000 (J-25730-A)

#### CAUTION:

- Do not damage the outer socket boots.
- Do not damage the outer socket threads. Thread the ball joint nut onto the end of the outer socket during removal.

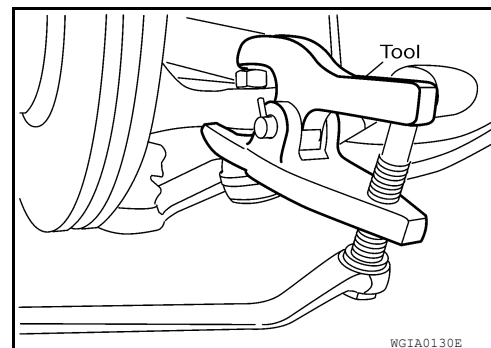

# POWER STEERING GEAR AND LINKAGE

## < REMOVAL AND INSTALLATION >

10. Remove the high-pressure and low-pressure piping from the steering gear assembly, then drain the fluid from the piping.

**CAUTION:**  
Do not reuse O-ring.

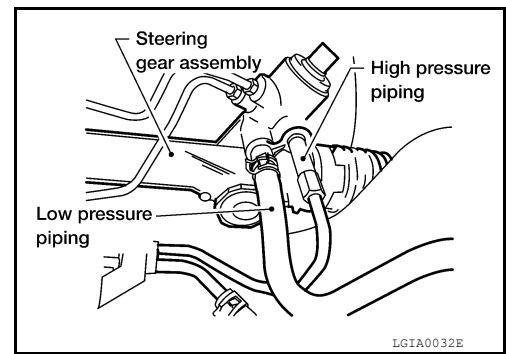

11. Remove the pinch bolt from the lower joint shaft, and separate the lower joint from the steering gear assembly.

**CAUTION:**  
• Do not damage the lower joint.

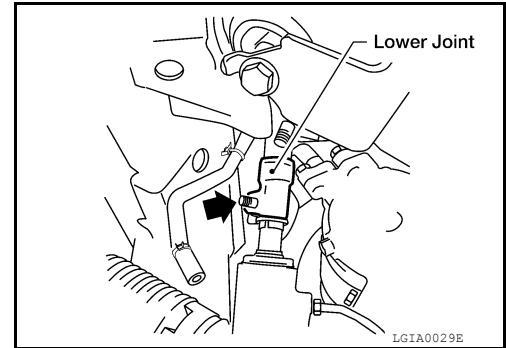

12. Remove the nuts and bolts of the steering gear assembly, using power tool, then remove the steering gear assembly from the vehicle.

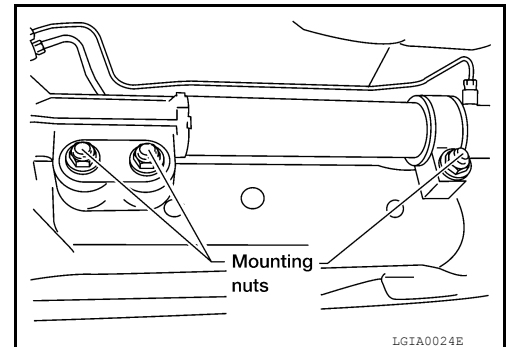

## INSTALLATION

Installation is in the reverse order of removal.

- With the steering wheel in the straight ahead position, align the slit of the lower joint with the projection on the dust cover. Insert the joint until surface (A) contacts surface (B).
- After removing/installing or replacing steering components, check wheel alignment. Refer to [FSU-6, "Front Wheel Alignment"](#).
- After adjusting wheel alignment, adjust neutral position of the steering angle sensor. Refer to [BRC-122, "ADJUSTMENT OF STEERING ANGLE SENSOR NEUTRAL POSITION : Special Repair Requirement"](#) (TYPE 1), [BRC-122, "ADJUSTMENT OF STEERING ANGLE SENSOR NEUTRAL POSITION : Special Repair Requirement"](#).
- Bleed the air from the steering hydraulic system. Refer to [ST-6, "Air Bleeding Hydraulic System"](#).

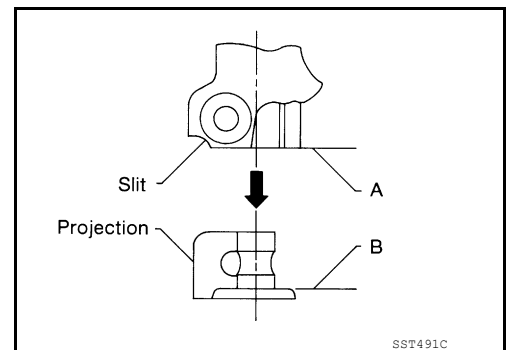

## INSPECTION AFTER INSTALLATION

- Check that the steering wheel turns smoothly to the left and right locks.
- Check that the number of turns are the same from the straight-forward position to the left and right locks.
- Check that the steering wheel is in the neutral position when driving straight ahead.



# POWER STEERING OIL PUMP

< REMOVAL AND INSTALLATION >

## POWER STEERING OIL PUMP

### Component

INFOID:000000007360010

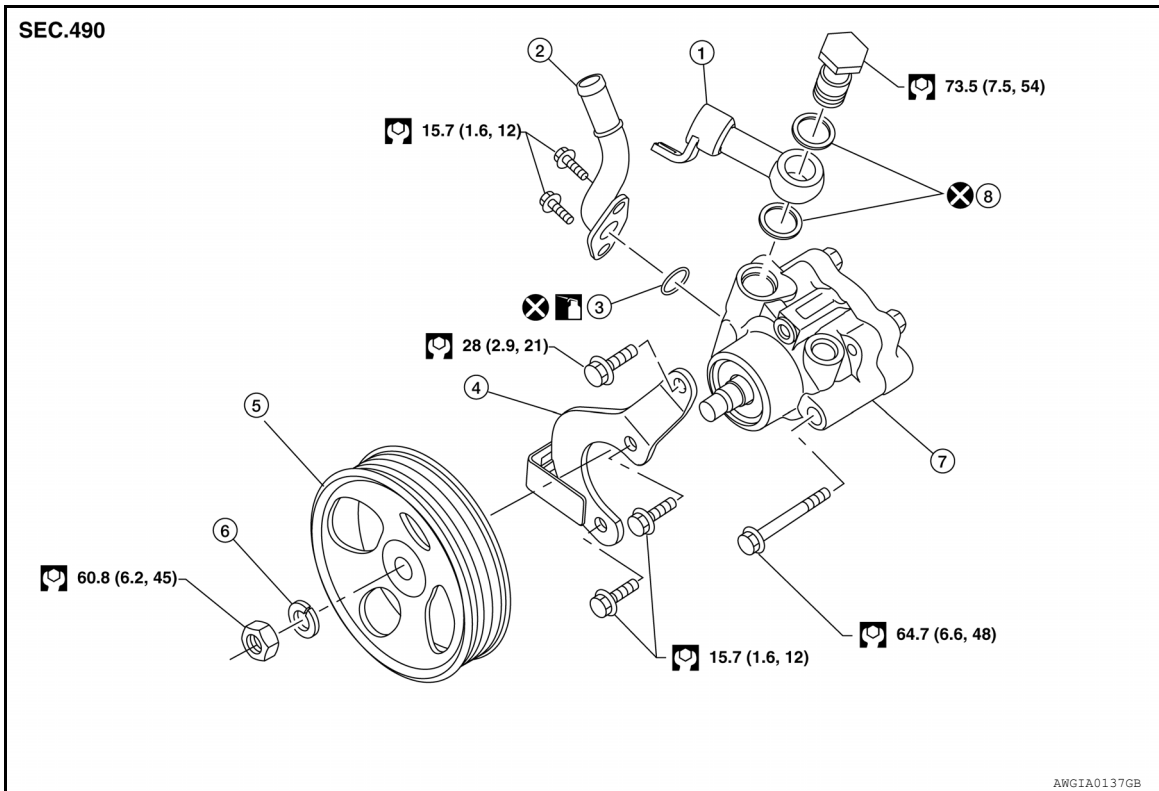

- |                  |                           |  |
|------------------|---------------------------|--|
| 1. Joint         | 2. Suction pipe           | 3. O-ring                              |
| 4. Front bracket | 5. Pulley                 | 6. Lock washer                         |
| 7. Body assembly | 8. Copper sealing washers | Apply Genuine Nissan PSF or equivalent |

### Removal and Installation

INFOID:000000007360011

#### NOTE:

When removing components such as hoses, tubes/lines, etc., cap or plug openings to prevent fluid from spilling.

#### REMOVAL

1. Drain the power steering fluid from the reservoir tank.
2. Remove the coolant fan. Refer to [CO-19, "Removal and Installation \(Motor driven type\)"](#).
3. Remove the air duct assembly. Refer to [EM-24, "Exploded View"](#).
4. Remove the serpentine drive belt from the auto tensioner and power steering oil pump. Refer to [EM-13, "Removal and Installation"](#).
5. Disconnect the pressure sensor electrical connector.
6. Remove the high pressure and low pressure piping from the power steering oil pump. Refer to [ST-19, "Removal and Installation"](#).

#### CAUTION:

**Do not reuse copper sealing washers.**

7. Remove the power steering oil pump bolts, then remove the power steering pump.

#### INSTALLATION

Installation is in the reverse order of removal.

#### CAUTION:

**Do not reuse copper sealing washers.**

# POWER STEERING OIL PUMP

## < REMOVAL AND INSTALLATION >

- Install the bolts to specification in the order shown.
- After installation, bleed the air from the hydraulic circuit thoroughly. Refer to [ST-6. "Air Bleeding Hydraulic System"](#).

<b>Power steering pump to bracket bolt (1)</b>	<b>64.7 N·m (6.6 kg-m, 48 ft-lb)</b>
<b>Power steering pump to block bolt (2)</b>	<b>28 N·m (2.9 kg-m, 21 ft-lb)</b>

### NOTE:

Belt tension is automatic and requires no adjustment.

## POWER STEERING OIL PUMP BRACKET

### Removal

1. Remove the power steering oil pump.
2. Remove the bolts and the power steering oil pump bracket.

### Installation

1. Position the bracket and install the bracket to block bolts but do not tighten. Finger tighten bolt (1) first to seat bracket to front of engine, then finger tighten bolts (2).
2. Tighten the bolts to specification in order as shown.

<b>Bracket to front of block bolt (1)</b>	<b>61.3 Nm (6.3 kg-m, 45 ft-lb)</b>
<b>Bracket to side of block bolt (2)</b>	<b>61.3 Nm (6.3 kg-m, 45 ft-lb)</b>

3. Install the power steering oil pump.

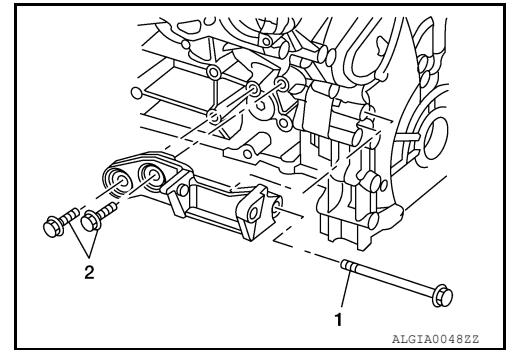
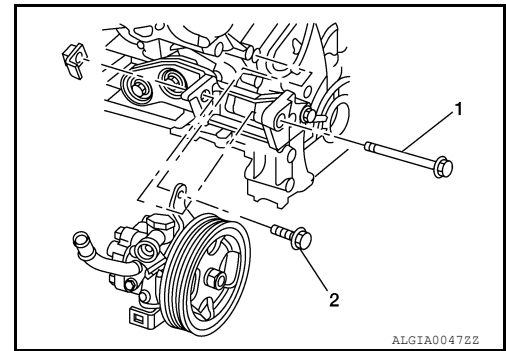

# HYDRAULIC LINE

< REMOVAL AND INSTALLATION >

## HYDRAULIC LINE

### Removal and Installation

INFOID:000000007360012

Refer to the following illustration for hydraulic line removal and installation.

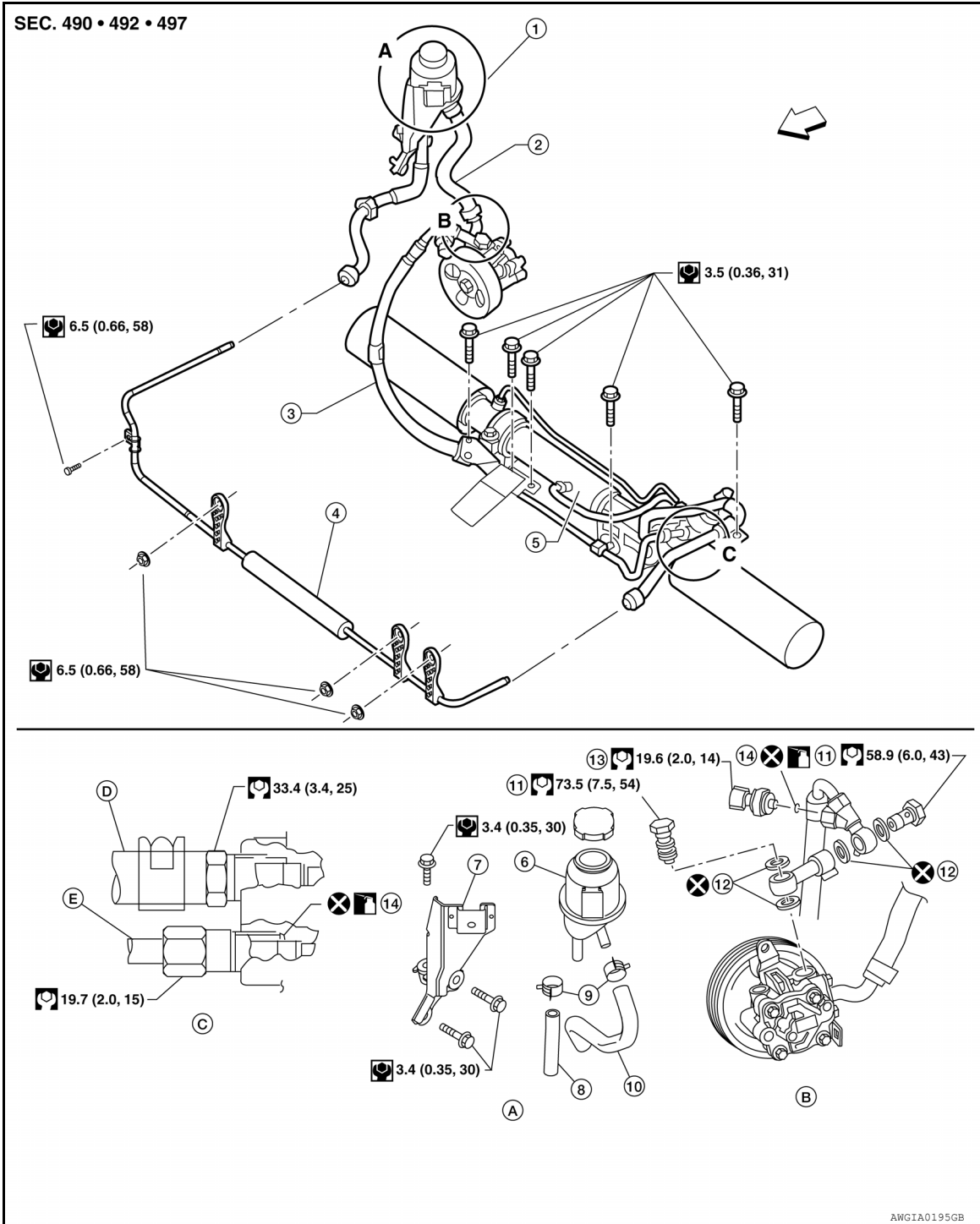

- |                           |                           |                            |
|---------------------------|---------------------------|----------------------------|
| 1. Reservoir tank         | 2. Suction hose           | 3. High pressure hose      |
| 4. Oil cooler             | 5. Steering gear assembly | 6. Reservoir tank          |
| 7. Reservoir tank bracket | 8. Return hose            | 9. Hose clamps             |
| 10. Suction hose          | 11. Connector bolts       | 12. Copper sealing washers |

## HYDRAULIC LINE

### < REMOVAL AND INSTALLATION >

---

13. Power steering pressure sensor

14. O-ring

D. Low pressure hose

E. High pressure hose



Apply Genuine Nissan PSF or equivalent

← Front

#### **CAUTION:**

**Do not reuse O-rings or copper sealing washers.**

#### **NOTE:**

When removing components such as hoses, tubes/lines, etc., cap or plug openings to prevent fluid from spilling.

# STEERING COLUMN

< UNIT DISASSEMBLY AND ASSEMBLY >

## UNIT DISASSEMBLY AND ASSEMBLY

### STEERING COLUMN

Disassembly and Assembly

INFOID:000000007360013

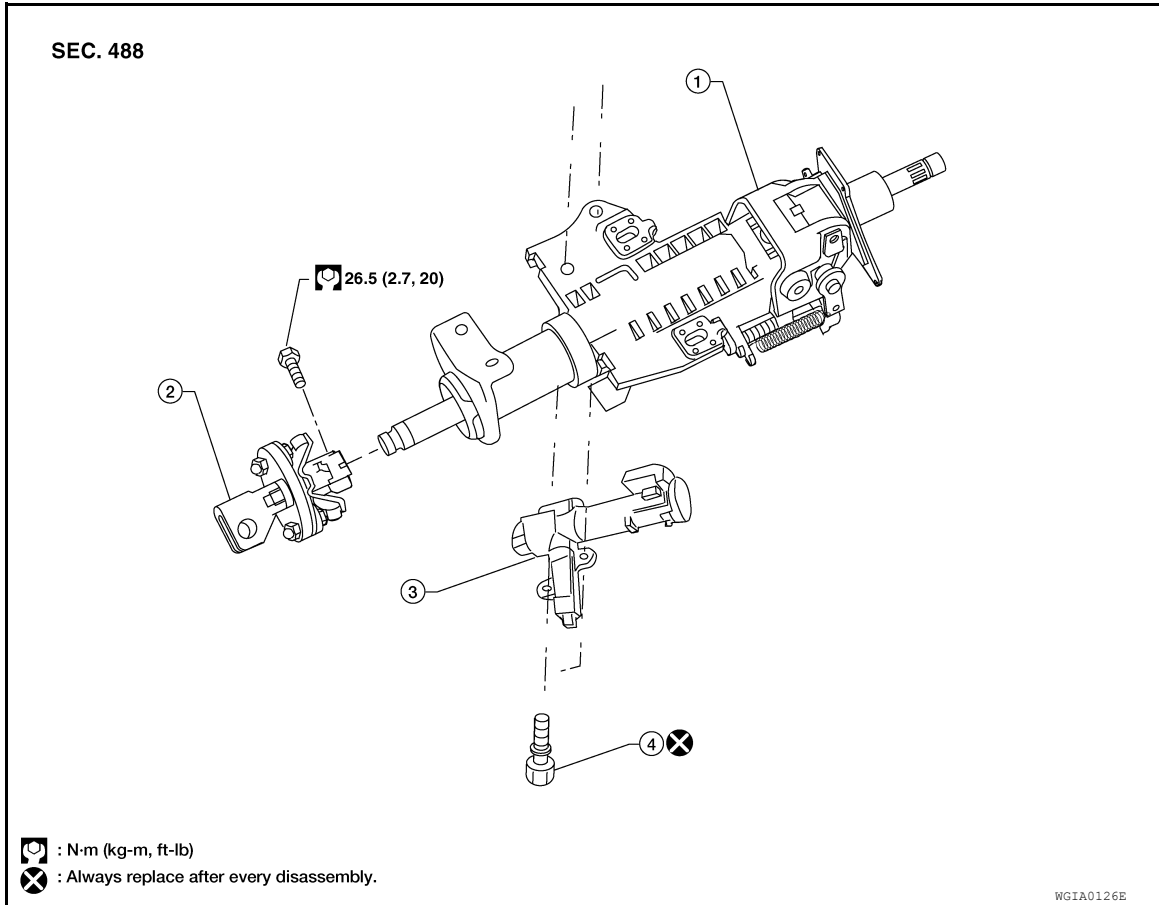

- 1. Steering column assembly
- 2. Upper joint
- 3. Ignition switch
- 4. Self-shear screw

#### DISASSEMBLY

1. Remove the bolt from the upper joint, then remove the upper joint from the steering column assembly.
2. Remove the ignition switch tamper resistant self-shear screws, using a drill.
3. Remove the ignition switch from the steering column.

#### ASSEMBLY

Assembly is in the reverse order of disassembly.

#### CAUTION:

Anytime the ignition switch has removed or installed, the keys must be re-registered in the BCM. Refer to CONSULT operation manual IVIS/NVIS.

#### NOTE:

# STEERING COLUMN

## < UNIT DISASSEMBLY AND ASSEMBLY >

Install new tamper resistant self-shear screws.

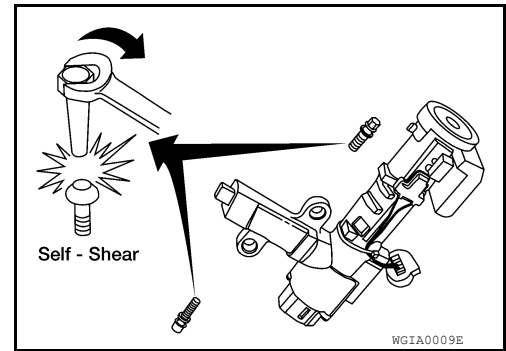

## INSPECTION AFTER ASSEMBLY

When the steering wheel does not turn smoothly, check as follows:

1. Check the steering column for the following:
  - Damage to the column tube or bearings
  - Wear around the seal edges
  - Corrosion or pitting around the seal sliding area

Replace the steering column as an assembly, if necessary.

### CAUTION:

- Do not exert any axial load or impact to the steering column.
  - Replace the column if it is depleted of grease, worn, damaged, or if any scratches or coating separation is present on the shaft seal area.
2. If the vehicle has been in a collision, or if noises are heard coming from the steering column, check column length. If out of specification, replace the steering column as an assembly.

**Steering column length (L)** : Refer to [ST-28, "Steering Column"](#)

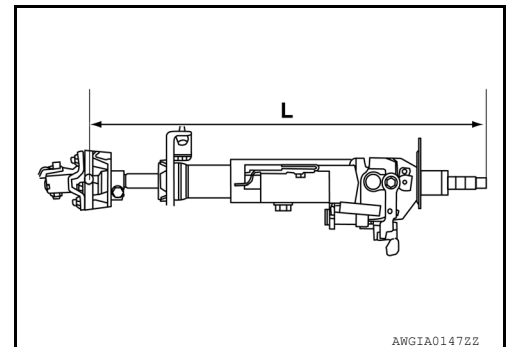

3. Check the tilt device for proper operation range.

**Range (A)** : Refer to [ST-28, "Steering Column"](#)

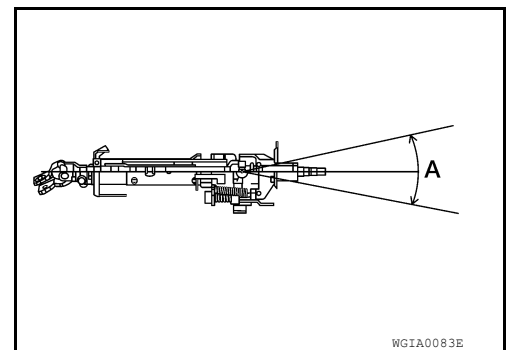

# POWER STEERING OIL PUMP

< UNIT DISASSEMBLY AND ASSEMBLY >

## POWER STEERING OIL PUMP

### Disassembly and Assembly

INFOID:000000007360014

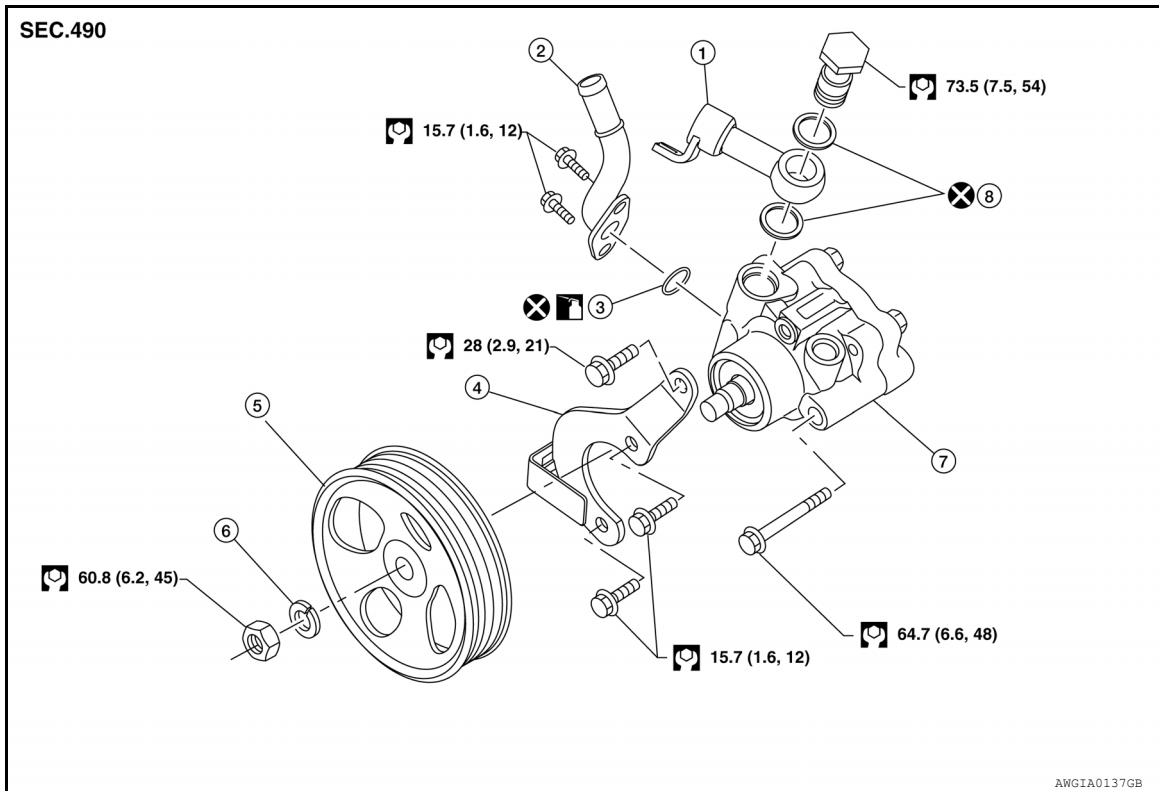

- |                  |                           |  |
|------------------|---------------------------|--|
| 1. Connector     | 2. Suction pipe           | 3. O-ring                              |
| 4. Bracket       | 5. Pulley                 | 6. Lock washer                         |
| 7. Body assembly | 8. Copper sealing washers | Apply Genuine Nissan PSF or equivalent |

### INSPECTION BEFORE DISASSEMBLY

Disassemble the power steering oil pump only if the following items are found.

- Deformed or damaged pulley, bracket, connector or suction pipe
- Oil leakage from the suction pipe or connector.

### DISASSEMBLY

#### NOTE:

Mount the power steering oil pump in a vise as needed.

1. Remove the connector bolt, connector and copper sealing washers.

#### CAUTION:

**Do not reuse the copper sealing washers.**

2. Remove the suction pipe and O-ring.

#### CAUTION:

**Do not reuse the O-ring.**

3. Remove the pulley nut and pulley.
4. Remove the bracket bolts and bracket.

### INSPECTION AFTER DISASSEMBLY

#### Body Assembly Inspection

Check the power steering oil pump body assembly for damage. If any damage is found, replace with a new power steering oil pump assembly.

### ASSEMBLY

Assembly is in the reverse order of disassembly.

## POWER STEERING OIL PUMP

< UNIT DISASSEMBLY AND ASSEMBLY >

---

**CAUTION:**

- Do not reuse the copper sealing washers.
- Do not reuse the O-ring. Apply a coat of Genuine NISSAN PSF or equivalent to the O-ring. Refer to [MA-13, "Fluids and Lubricants"](#).



# STEERING GEAR AND LINKAGE

< UNIT DISASSEMBLY AND ASSEMBLY >

## STEERING GEAR AND LINKAGE

### Disassembly and Assembly

INFOID:000000007360015

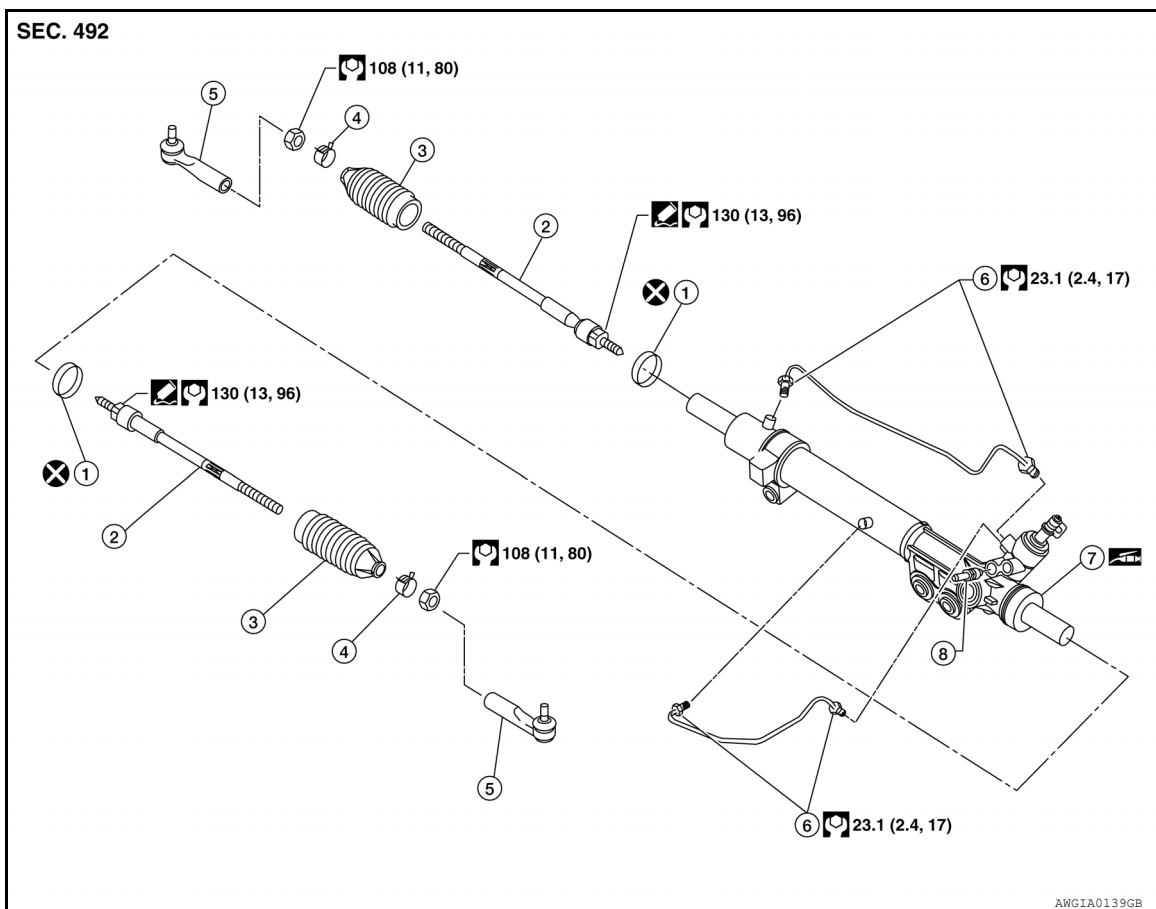

- |                          |                 |                   |
|--------------------------|-----------------|-------------------|
| 1. Boot clamp            | 2. Inner socket | 3. Boot           |
| 4. Boot clamp            | 5. Outer socket | 6. Cylinder tubes |
| 7. Gear housing assembly | 8. Connector    |                   |

#### CAUTION:

- Secure the gear housing assembly with a vise. Use copper plates or equivalent to prevent it from being damaged. Do not grip the cylinder with a vise.
- Before performing disassembly, clean the gear housing assembly. Be careful not to allow any cleaner to contact the discharge and return port connectors.

#### DISASSEMBLY

1. Remove the cylinder tubes from the gear housing assembly.
2. Loosen the lock nuts of the outer sockets, then remove the outer sockets from the inner sockets.
3. Remove the boot clamps from the boots, then remove the boots from the inner sockets and gear housing assembly.

#### CAUTION:

- Do not reuse the large-diameter boot clamps.
  - Do not damage the boots, inner socket or gear housing assembly. If they are damaged, replace them.
4. Remove the inner sockets.

#### INSPECTION AFTER DISASSEMBLY

##### Boot

Check boot for tears, cracks and deformation. Replace if necessary.

# STEERING GEAR AND LINKAGE

## < UNIT DISASSEMBLY AND ASSEMBLY >

### Gear Housing Assembly

Check gear housing assembly for dents, cracks or damage. Replace as an assembly if necessary.

### Outer Socket and Inner Socket

#### SWING TORQUE

- Measure the swing torque, using Tool. When ball stud and inner socket start moving the measured value must be within the specification. If the reading is outside the specification, replace the socket.

**Tool number** : — (J-44372)

**Outer socket swing torque** Refer to [ST-29, "Steering Gear"](#)

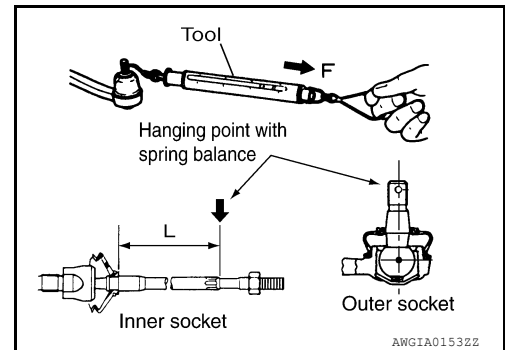

Item	Outer socket	Inner socket
Measuring point	Cotter pin hole of stud	Refer to <a href="#">ST-29, "Steering Gear"</a>
Swing torque	Refer to <a href="#">ST-29, "Steering Gear"</a>	Refer to <a href="#">ST-29, "Steering Gear"</a>
Measuring value	<a href="#">ST-29, "Steering Gear"</a>	Refer to <a href="#">ST-29, "Steering Gear"</a>

#### ROTATING TORQUE

- Measure the rotating torque, using Tool. If the value is outside the specification, replace the outer sockets.

**Tool number** : ST3127S000 (J-25765-A)

**Outer socket rotating torque** Refer to [ST-29, "Steering Gear"](#)

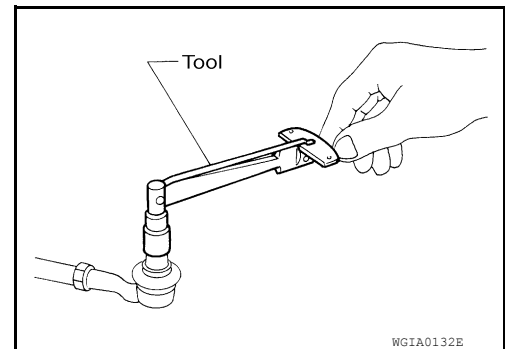

#### AXIAL END PLAY

- Apply a load of 490 N (50 kg-f, 110 lb-f) to the ball stud axially. Use a dial gauge to measure the amount of the movement that the stud makes. If the value is outside the specification, replace the sockets.

**Outer socket** : Refer to [ST-29, "Steering Gear"](#)

**Inner socket** : Refer to [ST-29, "Steering Gear"](#)

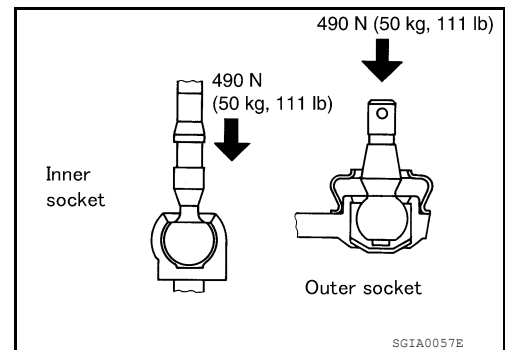

## ASSEMBLY

1. Install the inner sockets.

# STEERING GEAR AND LINKAGE

## < UNIT DISASSEMBLY AND ASSEMBLY >

2. Install the large-diameter side of the boots to the gear housing assembly.
3. Install the small-diameter side of the boots to the groove of the inner sockets.

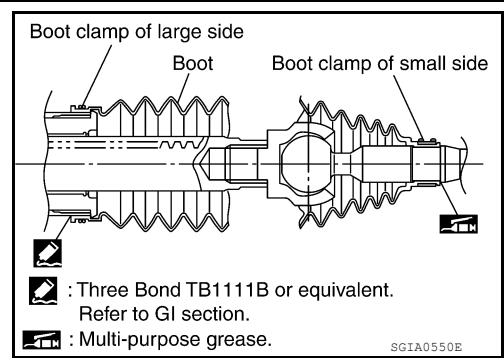

4. Install the boot clamps to the boots, as shown.

**CAUTION:**  
Do not reuse the large boot clamps.

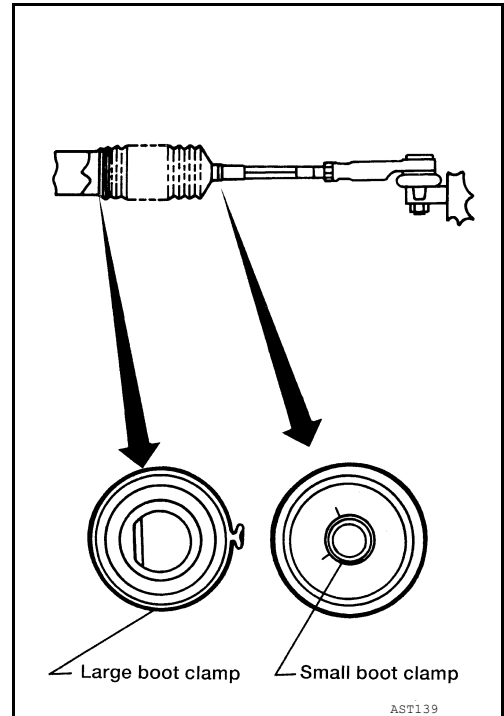

5. Crimp the large boot clamps, using Tool.

**Tool number** : KV40107300 ( — )

6. Install the cylinder tubes to the gear housing assembly.
7. Install the lock nuts and outer sockets to the inner sockets.

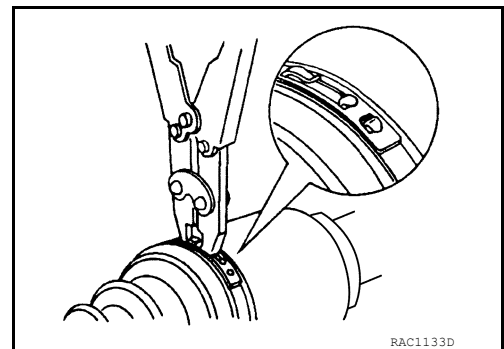

8. Thread the outer sockets onto the inner sockets to the specified length (L), then tighten the lock nuts to the specified torque. Refer to "Disassembly and Assembly". Reconfirm that the inner socket length (L) is within specification.

**Inner socket length (L)** : [ST-29, "Steering Gear"](#)

**CAUTION:**  
Adjust toe-in after this procedure. The length achieved after toe-in adjustment may not be the above value.

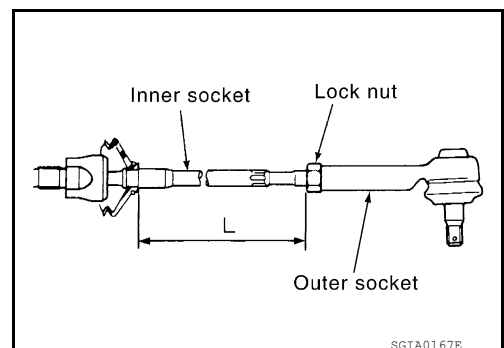

A  
B  
C  
D  
E  
F  
ST  
H  
I  
J  
K  
L  
M  
N  
O  
P

# SERVICE DATA AND SPECIFICATIONS (SDS)

< SERVICE DATA AND SPECIFICATIONS (SDS)

## SERVICE DATA AND SPECIFICATIONS (SDS)

### SERVICE DATA AND SPECIFICATIONS (SDS)

#### Steering Wheel

INFOID:000000007360016

End play of the axle direction for steering wheel	0 mm (0 in)
Steering wheel turning force	39 N (4 kg-f, 9 lb-f) or less
Steering wheel play on the outer circumference	0 – 35 mm (0 – 1.38 in)

#### Steering Column

INFOID:000000007360017

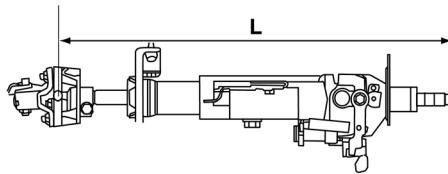

AWGIA01472Z

Steering column length	553.0 mm (21.77 in)
------------------------	---------------------

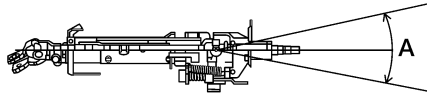

WGIA0083E

Tilt range (A)	18° - 21° of tilt range
----------------	-------------------------

#### Tie-rod

INFOID:000000007837594

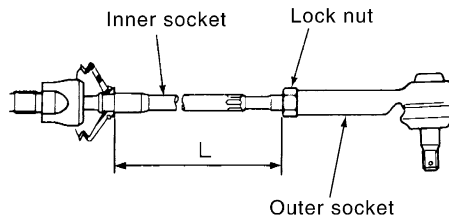

SGIA0167E

Tie-rod length (L)	Maximum	84.0 mm (3.31 in)
	Nominal (before toe-in adjustment)	79.0 mm (3.11 in)

# SERVICE DATA AND SPECIFICATIONS (SDS)

## < SERVICE DATA AND SPECIFICATIONS (SDS)

### Steering Gear

INFOID:000000007360018

Steering gear type	PR26AM
--------------------	--------

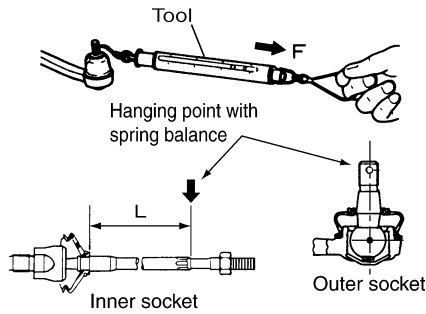

Outer socket	Swinging torque	0.3 – 2.9 N·m (0.03 – 0.29 kg-m, 3 – 25 in-lb)
	Measurement on spring balance • Measuring point: cotter pin hole of stud	4.84 – 46.7 N (0.50 – 4.7 kg-f, 4 – 34 lb-f)
	Rotating torque	0.3 – 2.9 N·m (0.03 – 0.29 kg-m, 3 – 25 in-lb)
	Axial end play	0.5 mm (0.020 in) or less
Inner socket	Swinging torque	1.0 – 7.8 N·m (0.11 – 0.79 kg-m, 9 – 69 in-lb)
	Measurement on spring balance • Measuring point: L mark see above L=84.0 mm (3.31 in)	12.1 – 93.7 N (1.3 – 9.5 kg-f, 9 – 69 lb-f)
	Axial end play	0.2 mm (0.08 in) or less
Rack sliding force	Standard	280 ± 30 N (28.6 ± 3.1 kg-f, 62.9 ± 6.7 lb-f)
	Minimum	210 N (21.4 kg-f, 47.2 lb-f)

### Oil Pump

INFOID:000000007360020

Oil pump relief hydraulic pressure	8.3 +0.5, -0.3 mPa (84.66 +5.10, -3.06 kg/cm <sup>2</sup> , 1203.5 +72.5, -43.5 psi)
------------------------------------	--

### Steering Fluid

INFOID:000000007360021

Fluid capacity	Approx. 1.0 ℓ (2 1/8 US pt, 1 3/4 Imp pt)
Fluid type	Refer to <a href="#">MA-13. "Fluids and Lubricants"</a> .