

A
EM
C
D
E
F
G
H
I
J
K
L
M
N
O
P

SECTION **EM**

ENGINE MECHANICAL

CONTENTS

VQ40DE

PRECAUTION	3	REMOVAL AND INSTALLATION	15
PRECAUTIONS	3	SPARK PLUG	16
Precaution for Supplemental Restraint System (SRS) "AIR BAG" and "SEAT BELT PRE-TENSIONER"	3	Exploded View	16
Precaution for Drain Engine Coolant	3	Removal and Installation	16
Precaution for Disconnecting Fuel Piping	3	CAMSHAFT VALVE CLEARANCE	18
Precaution for Removal and Disassembly	3	Valve Clearance	18
Precaution for Inspection, Repair and Replacement	3	COMPRESSION PRESSURE	22
Precaution for Assembly and Installation	4	Compression Pressure	22
Parts Requiring Angle Tightening	4	REMOVAL AND INSTALLATION	24
Precaution for Liquid Gasket	4	AIR CLEANER AND AIR DUCT	24
PREPARATION	6	Exploded View	24
PREPARATION	6	Removal and Installation	24
Special Service Tool	6	INTAKE MANIFOLD COLLECTOR	25
Commercial Service Tool	8	Exploded View	25
SYSTEM DESCRIPTION	11	Removal and Installation	25
NOISE, VIBRATION AND HARSHNESS (NVH) TROUBLESHOOTING	11	INTAKE MANIFOLD	28
NVH Troubleshooting - Engine Noise	11	Exploded View	28
Use the Chart Below to Help You Find the Cause of the Symptom	11	Removal and Installation	28
PERIODIC MAINTENANCE	13	EXHAUST MANIFOLD AND THREE WAY CATALYST	30
DRIVE BELTS	13	Exploded View	30
Exploded View	13	Removal and Installation (Three Way Catalyst)	30
Checking Drive Belts	13	Removal and Installation (Exhaust Manifold)	31
Adjustment	13	OIL PAN AND OIL STRAINER	34
Removal and Installation	13	Exploded View	34
Drive Belt Auto-Tensioner and Idler Pulley	14	Removal and Installation	34
AIR CLEANER FILTER	15	IGNITION COIL	40
Exploded View	15	Exploded View	40
		Removal and Installation	40
		ROCKER COVER	41
		Exploded View	41
		Removal and Installation	41

FUEL INJECTOR AND FUEL TUBE	45	Removal and Installation of Front Oil Seal	85
Exploded View	45	Removal and Installation of Rear Oil Seal	86
Removal and Installation	45	CYLINDER HEAD	88
INTAKE VALVE TIMING CONTROL	50	Exploded View	88
Intake Valve Timing Control Solenoid Valve (LH)...	50	Removal and Installation	88
Intake Valve Timing Control Solenoid Valve (RH)...	50	Exploded View	92
FRONT TIMING CHAIN CASE	51	Disassembly and Assembly	92
Exploded View	51	Inspection After Disassembly	94
Removal and Installation	51	UNIT REMOVAL AND INSTALLATION	99
TIMING CHAIN	59	ENGINE ASSEMBLY	99
Exploded View	59	Exploded View	99
Removal and Installation	59	Removal and Installation	99
TIMING CHAIN TENSIONER	67	UNIT DISASSEMBLY AND ASSEMBLY ..	102
Exploded View	67	ENGINE UNIT	102
Removal and Installation (Primary Timing Chain		Exploded View	102
Tensioner)	67	Disassembly and Assembly	103
Removal and Installation (Secondary Timing		Inspection After Disassembly	112
Chain Tensioner)	68	Dowel Pin Alignment	123
Removal and Installation (Secondary Timing		HOW TO SELECT PISTON AND BEARING ..	125
Chain Tensioner Shoe)	68	How to Select Piston and Bearing	125
REAR TIMING CHAIN CASE	70	SERVICE DATA AND SPECIFICATIONS	
Exploded View	70	(SDS)	130
Removal and Installation	70	SERVICE DATA AND SPECIFICATIONS	
CAMSHAFT	75	(SDS)	130
Exploded View	75	Standard and Limit	130
Removal and Installation	76		
OIL SEAL	85		
Removal and Installation of Valve Oil Seal	85		

PRECAUTION

PRECAUTIONS

Precaution for Supplemental Restraint System (SRS) "AIR BAG" and "SEAT BELT PRE-TENSIONER"

INFOID:000000011069667

The Supplemental Restraint System such as "AIR BAG" and "SEAT BELT PRE-TENSIONER", used along with a front seat belt, helps to reduce the risk or severity of injury to the driver and front passenger for certain types of collision. This system includes seat belt switch inputs and dual stage front air bag modules. The SRS system uses the seat belt switches to determine the front air bag deployment, and may only deploy one front air bag, depending on the severity of a collision and whether the front occupants are belted or unbelted. Information necessary to service the system safely is included in the SR and SB section of this Service Manual.

WARNING:

- To avoid rendering the SRS inoperative, which could increase the risk of personal injury or death in the event of a collision which would result in air bag inflation, all maintenance must be performed by an authorized NISSAN/INFINITI dealer.
- Improper maintenance, including incorrect removal and installation of the SRS, can lead to personal injury caused by unintentional activation of the system. For removal of Spiral Cable and Air Bag Module, see the SR section.
- Do not use electrical test equipment on any circuit related to the SRS unless instructed to in this Service Manual. SRS wiring harnesses can be identified by yellow and/or orange harnesses or harness connectors.

PRECAUTIONS WHEN USING POWER TOOLS (AIR OR ELECTRIC) AND HAMMERS

WARNING:

- When working near the Airbag Diagnosis Sensor Unit or other Airbag System sensors with the Ignition ON or engine running, DO NOT use air or electric power tools or strike near the sensor(s) with a hammer. Heavy vibration could activate the sensor(s) and deploy the air bag(s), possibly causing serious injury.
- When using air or electric power tools or hammers, always switch the Ignition OFF, disconnect the battery and wait at least three minutes before performing any service.

Precaution for Drain Engine Coolant

INFOID:000000011069668

Drain engine coolant when engine is cooled.

Precaution for Disconnecting Fuel Piping

INFOID:000000011069669

- Before starting work, make sure no fire or spark producing items are in the work area.
- Release fuel pressure before disconnecting and disassembly.
- After disconnecting pipes, plug openings to stop fuel leakage.

Precaution for Removal and Disassembly

INFOID:000000011069670

- When instructed to use special service tools, use the specified tools. Always be careful to work safely, avoid forceful or uninstructed operations.
- Exercise maximum care to avoid damage to mating or sliding surfaces.
- Cover openings of engine system with tape or equivalent, if necessary, to seal out foreign materials.
- Mark and arrange disassembly parts in an organized way for easy troubleshooting and re-assembly.
- When loosening nuts and bolts, as a basic rule, start with the one furthest outside, then the one diagonally opposite, and so on. If the order of loosening is specified, do exactly as specified. Power tools may be used in the step.

Precaution for Inspection, Repair and Replacement

INFOID:000000011069671

Before repairing or replacing, thoroughly inspect parts. Inspect new replacement parts in the same way, and replace if necessary.

A
EM
C
D
E
F
G
H
I
J
K
L
M
N
O
P

PRECAUTIONS

[VQ40DE]

< PRECAUTION >

Precaution for Assembly and Installation

INFOID:000000011069672

- Use torque wrench to tighten bolts or nuts to specification.
- When tightening nuts and bolts, as a basic rule, equally tighten in several different steps starting with the ones in center, then ones on inside and outside diagonally in this order. If the order of tightening is specified, do exactly as specified.
- Replace with new gasket, packing, oil seal or O-ring.
- Thoroughly wash, clean, and air-blow each part. Carefully check engine oil or engine coolant passages for any restriction and blockage.
- Avoid damaging sliding or mating surfaces. Completely remove foreign materials such as cloth lint or dust. Before assembly, oil sliding surfaces well.
- Release air within route when refilling after draining engine coolant.
- Before starting engine, apply fuel pressure to fuel lines with turning ignition switch ON (with engine stopped). Then make sure that there are no leaks at fuel line connections.
- After repairing, start engine and increase engine speed to check engine coolant, fuel, engine oil, and exhaust gasses for leakage.

Parts Requiring Angle Tightening

INFOID:000000011069673

- For the final tightening of the following engine parts use Tool:

Tool number : KV10112100 (BT-8653-A)

- Cylinder head bolts
- Lower cylinder block bolts
- Connecting rod cap bolts
- Crankshaft pulley bolt (No angle wrench is required as bolt flange is provided with notches for angle tightening)
- Do not use a torque value for final tightening.
- The torque value for these parts are for a preliminary step.
- Ensure thread and seat surfaces are clean and coated with engine oil.

Precaution for Liquid Gasket

INFOID:000000011069674

REMOVAL OF LIQUID GASKET

- After removing the bolts and nuts, separate the mating surface and remove the old liquid gasket using Tool.

Tool number : KV10111100 (J-37228)

CAUTION:

Do not damage the mating surfaces.

- Tap the seal cutter to insert it (1).
- In areas where the Tool is difficult to use, lightly tap to slide it (2).

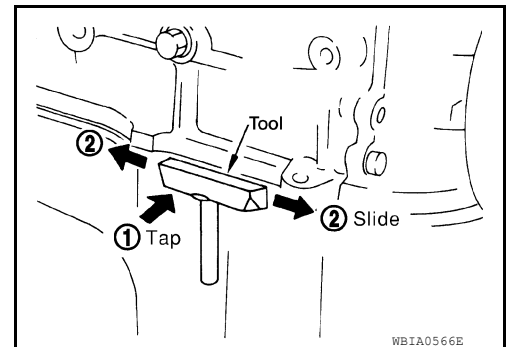

LIQUID GASKET APPLICATION PROCEDURE

1. Remove the old liquid gasket adhering to the gasket application surface and the mating surface using suitable tool.
 - Remove the liquid gasket completely from the groove of the liquid gasket application surface, bolts, and bolt holes.
2. Thoroughly clean the mating surfaces and remove adhering moisture, grease and foreign material.

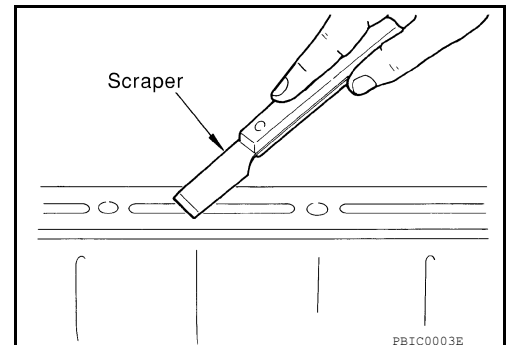

PRECAUTIONS

[VQ40DE]

< PRECAUTION >

3. Attach the liquid gasket tube to the suitable tool.
Use Genuine RTV Silicone Sealant or equivalent. Refer to [GI-21, "Recommended Chemical Products and Sealants"](#).
4. Apply the liquid gasket without breaks to the specified location with the specified dimensions.

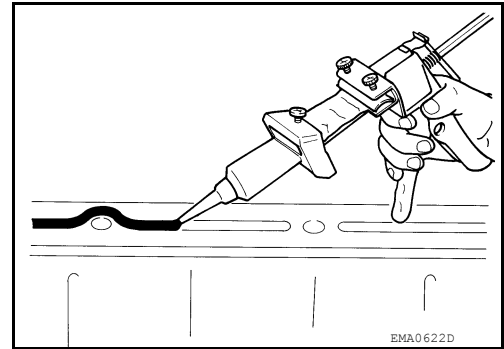

- If there is a groove for the liquid gasket application, apply the liquid gasket to the groove.
- Normally apply the liquid gasket on the inside edge of the bolt holes. Also apply to the outside edge of the bolt holes when specified in the procedure.
- Within five minutes of liquid gasket application, install the mating component.
- If the liquid gasket protrudes, wipe it off immediately.
- Do not retighten after the installation.
- Wait 30 minutes or more after installation before refilling the engine with oil or coolant.

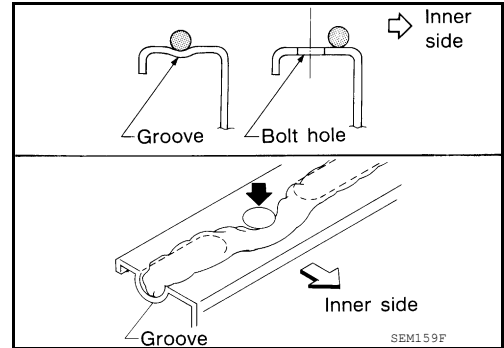

CAUTION:

If there are more specific instructions in the procedures contained in this manual concerning liquid gasket application, observe them.

PREPARATION

< PREPARATION >

[VQ40DE]



PREPARATION

PREPARATION

Special Service Tool

INFOID:000000011069675

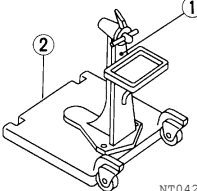
The actual shape of the tools may differ from those illustrated here.

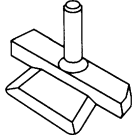
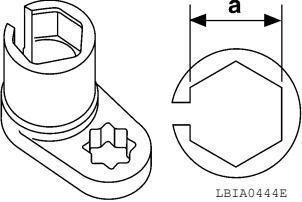
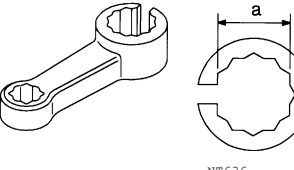
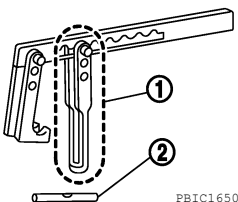
Tool number (TechMate No.) Tool name	Description
ST0501S000 (—) Engine stand assembly 1. ST05011000 (—) Engine stand 2. ST05012000 (—) Base	Disassembling and assembling engine 
16441 6N210 (J-45488) Quick connector release	Removing fuel tube quick connectors in engine room. 
KV10111100 (J-37228) Seal cutter	Removing oil pan (lower and upper), front and rear timing chain case, etc. 
KV991J0050 (J-44626) Air fuel sensor Socket	Loosening or tightening air fuel ratio A/F sensor a: 22 mm (0.87 in) 
KV10114400 (J-38365) Heated oxygen sensor wrench	Loosening or tightening heated oxygen sensor 1 a: 22 mm (0.87 in) 
KV10116200 (J-26336-B) Valve spring compressor 1. KV10115900 (J-26336-20) Attachment 2. KV10109220 (—) Adapter	Disassembling valve mechanism Part (1) is a component of KV10116200 (J-26336-B), but Part (2) is not so. 

PREPARATION

< PREPARATION >

[VQ40DE]

Tool number (TechMate No.) Tool name	Description	
KV10107902 (J-38959) Valve oil seal puller	Replacing valve oil seal	A EM C
— (J-39386) Valve oil seal drift	Installing valve oil seal	D E F
KV10115600 (J-38958) Valve oil seal drift	Installing valve oil seal Use side A. a: 20 (0.79) dia. d: 8 (0.31) dia. b: 13 (0.51) dia. e: 10.7 (0.421) dia. c: 10.3 (0.406) dia. f: 5 (0.20) dia. Unit: mm (in)	G H
EM0347000 (J-8037) Piston ring compressor	Installing piston assembly into cylinder bore	I J K
KV10112100 (BT-8653-A) Angle wrench	Tightening bolts for cylinder head, main bearing cap and connecting rod cap	L M
ST16610001 (J-23907) Pilot bushing puller	Removing pilot converter	N O
— 1. (J-49815) 2. (J-8092) Seal installer and driver handle	Installing rear main seal	P

PREPARATION

< PREPARATION >

[VQ40DE]

Tool number (TechMate No.) Tool name	Description
KV11105210 (J-44716) Ring gear stopper	Removing and installing crankshaft pulley
— (J-50246) Tensioner shoe installer and chain tensioner pins	Installing secondary timing chain tensioner shoes and locking chain tensioners in compressed position

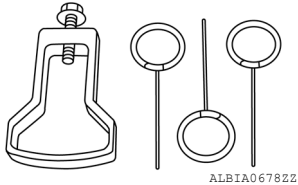
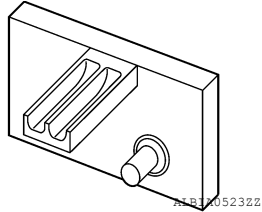

Commercial Service Tool

INFOID:000000011069676

Tool number (TechMate No.) Tool name	Description
— (—) 1. Crowfoot 2. Torque wrench	Installing exhaust manifold nuts a: 14 mm (0.55 in)
— (—) Power tool	Loosening nuts, screws and bolts
KV991J0100 (J-46531) Socket	Removing and installing flywheel Size: T55
— (—) Spark plug wrench	Removing and installing spark plug

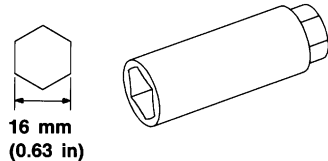
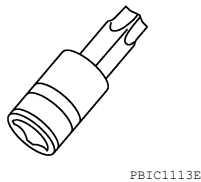
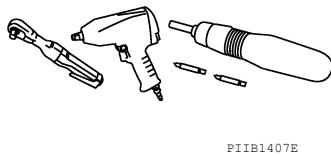
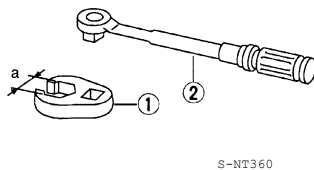

PREPARATION

< PREPARATION >

[VQ40DE]

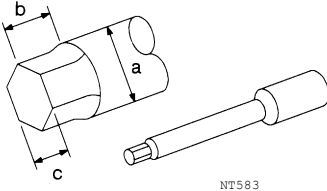
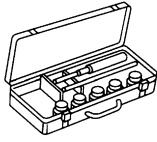
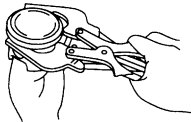
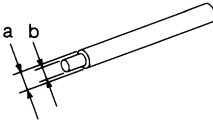
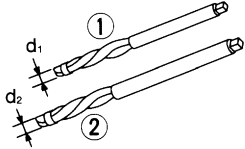
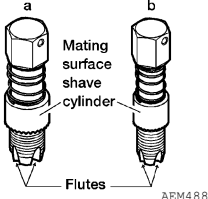
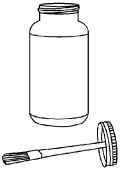
Tool number (TechMate No.) Tool name	Description	
<p>— (J-24239-01) Cylinder head bolt wrench</p> 	<p>Loosening and tightening cylinder head bolt, and used with angle wrench [SST: KV10112100 (BT8653-A)] a: 13 (0.51) dia. b: 12 (0.47) c: 10 (0.39) Unit: mm (in)</p>	<p>A EM C</p>
<p>— (—) Valve seat cutter set</p> 	<p>Finishing valve seat dimensions</p>	<p>D E F</p>
<p>— (—) Piston ring expander</p> 	<p>Removing and installing piston ring</p>	<p>G H</p>
<p>— (—) Valve guide drift</p> 	<p>Removing and installing valve guide Intake and Exhaust: a: 9.5 mm (0.374 in) dia. b: 5.5 mm (0.217 in) dia.</p>	<p>I J K</p>
<p>— (—) Valve guide reamer</p> 	<p>(1): Reaming valve guide inner hole (2): Reaming hole for oversize valve guide Intake and Exhaust: d1: 6.0 mm (0.236 in) dia. d2: 10.175 - 10.196 mm (0.4006 - 0.4014 in) dia.</p>	<p>L M</p>
<p>— (J-43897-18) (J-43897-12) Oxygen sensor thread cleaner</p> 	<p>Reconditioning the exhaust system threads before installing a new heated oxygen sensor (Use with anti-seize lubricant shown below.) a: J-43897-18 [18 mm (0.71 in) dia.] for zirconia heated oxygen sensor b: J-43897-12 [12 mm (0.47 in) dia.] for titania heated oxygen sensor</p>	<p>N O</p>
<p>— (—) Anti-seize lubricant (Permatex 133AR or equivalent meeting MIL specification MIL-A-907)</p> 	<p>Lubricating oxygen sensor thread cleaning tool when reconditioning exhaust system threads</p>	<p>P</p>

PREPARATION

< PREPARATION >

[VQ40DE]

Tool number (TechMate No.) Tool name	Description
— (—) Manual lift table caddy	Removing and installing engine
WS39930000 (—) Tube presser	Pressing the tube of liquid gasket

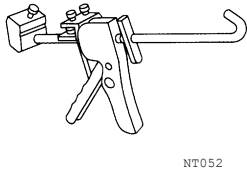
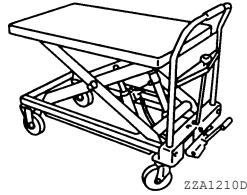

SYSTEM DESCRIPTION

NOISE, VIBRATION AND HARSHNESS (NVH) TROUBLESHOOTING

NVH Troubleshooting - Engine Noise

INFOID:000000011069677

A

EM

C

D

E

F

G

H

I

J

K

L

M

N

O

P

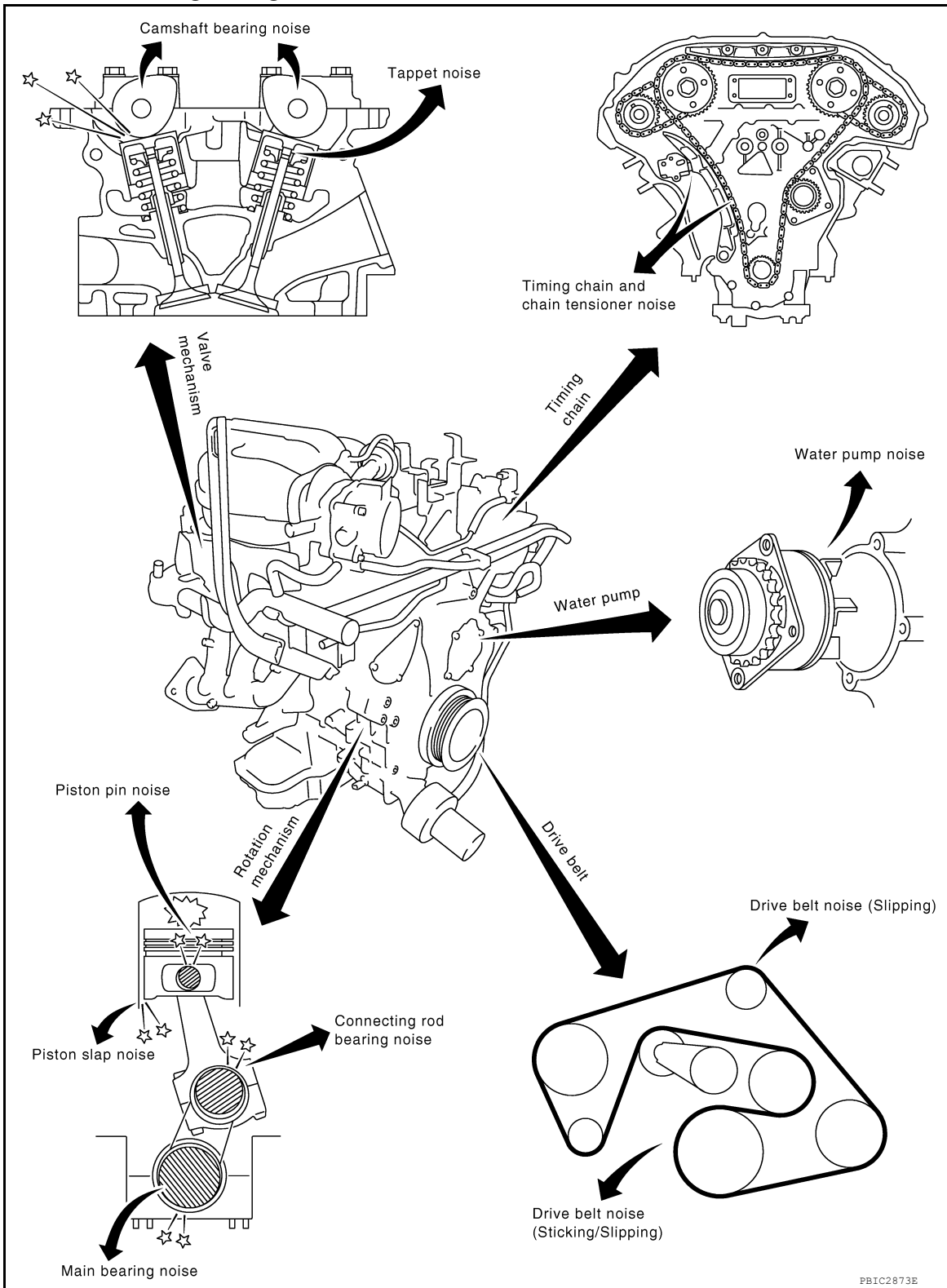

Use the Chart Below to Help You Find the Cause of the Symptom

INFOID:000000011069678

1. Locate the area where noise occurs.

NOISE, VIBRATION AND HARSHNESS (NVH) TROUBLESHOOTING

< SYSTEM DESCRIPTION >

[VQ40DE]

2. Confirm the type of noise.
3. Specify the operating condition of engine.
4. Check specified noise source.

If necessary, repair or replace these parts.

Location of noise	Type of noise	Operating condition of engine						Source of noise	Check item	Reference page
		Before warm-up	After warm-up	When starting	When idling	When racing	While driving			
Top of engine Rocker cover Cylinder head	Ticking or clicking	C	A	—	A	B	—	Tappet noise	Valve clearance	EM-18
	Rattle	C	A	—	A	B	C	Camshaft bearing noise	Camshaft runout Camshaft journal oil clearance	EM-76 EM-76
Crankshaft pulley Cylinder block (Side of engine) Oil pan	Slap or knock	—	A	—	B	B	—	Piston pin noise	Piston to piston pin oil clearance Connecting rod bushing oil clearance	EM-112 EM-112
	Slap or rap	A	—	—	B	B	A	Piston slap noise	Piston to cylinder bore clearance Piston ring side clearance Piston ring end gap Connecting rod bend and torsion	EM-112 EM-112 EM-112 EM-112
	Knock	A	B	C	B	B	B	Connecting rod bearing noise	Connecting rod bushing oil clearance Connecting rod bearing oil clearance	EM-112 EM-112
	Knock	A	B	—	A	B	C	Main bearing noise	Main bearing oil clearance Crankshaft runout	EM-112 EM-112
Front of engine Timing chain case	Tapping or ticking	A	A	—	B	B	B	Timing chain and chain tensioner noise	Timing chain cracks and wear Timing chain tensioner operation	EM-59 EM-67
Front of engine	Squeaking or fizzing	A	B	—	B	—	C	Drive belts (Sticking or slipping)	Drive belts deflection	EM-13
	Creaking	A	B	A	B	A	B	Drive belts (Slipping)	Idler pulley bearing operation	
	Squall Creak	A	B	—	B	A	B	Water pump noise	Water pump operation	CO-21
	Rattle	—	—	A	—	—	—	VTC	VTC lock pin clearance	EM-76

A: Closely related B: Related C: Sometimes related —: Not related

PERIODIC MAINTENANCE

DRIVE BELTS

Exploded View

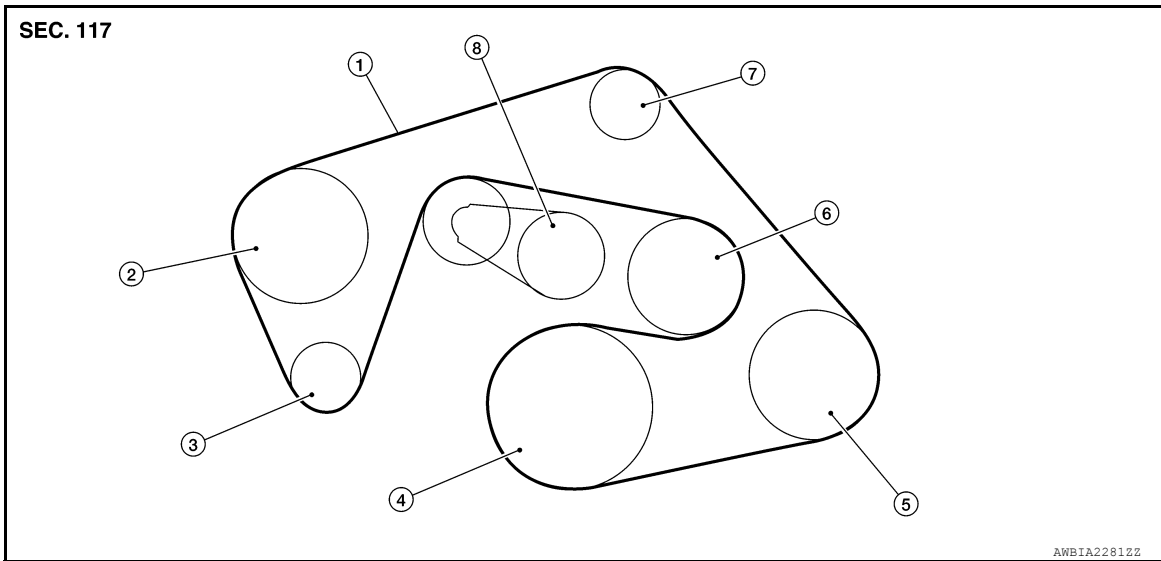

- | | | |
|----------------------|-----------------------------------|-----------------------|
| 1. Drive belt | 2. Power steering oil pump pulley | 3. Generator pulley |
| 4. Crankshaft pulley | 5. A/C compressor | 6. Cooling fan pulley |
| 7. Idler pulley | 8. Drive belt auto-tensioner | |

Checking Drive Belts

INFOID:000000011069680

WARNING:

Be sure to perform when the engine is stopped.

1. Remove air duct and resonator assembly when inspecting drive belt. Refer to [EM-24, "Removal and Installation"](#).
2. Make sure that the drive belt auto-tensioner indicator is within the allowable working range (A) as shown.
3. Visually check entire belt for wear, damage or cracks.
4. If the indicator is out of allowable working range or drive belt is damaged, replace the drive belt. Refer to [EM-13, "Removal and Installation"](#).

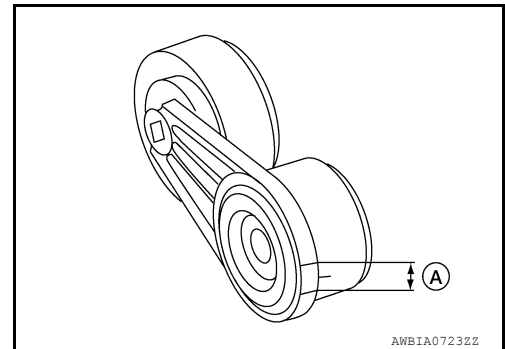

Adjustment

INFOID:000000011069681

There is no manual drive belt tension adjustment. The drive belt tension is automatically adjusted by the drive belt auto-tensioner.

Removal and Installation

INFOID:000000011069682

REMOVAL

1. Remove air duct and resonator assembly. Refer to [EM-24, "Removal and Installation"](#).

DRIVE BELTS

< PERIODIC MAINTENANCE >

[VQ40DE]

2. Rotate the drive belt auto-tensioner in the direction of arrow (loosening direction of tensioner) as shown, using suitable tool.

WARNING:

Avoid placing hand in a location where pinching may occur if the tool accidentally comes off.

3. Remove the drive belt.

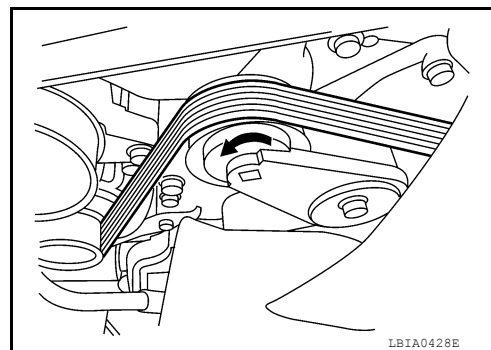

INSTALLATION

Installation is in the reverse order of removal.

CAUTION:

Make sure belt is securely installed around all pulleys.

Drive Belt Auto-Tensioner and Idler Pulley

INFOID:000000011069683

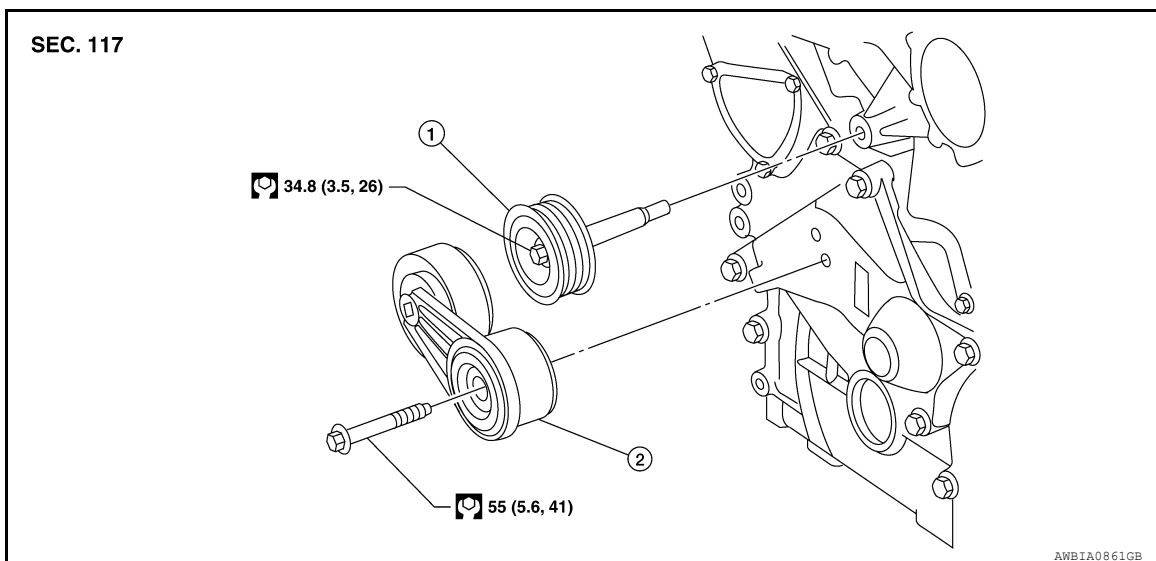

1. Idler pulley

2. Drive belt auto-tensioner

REMOVAL

1. Remove drive belt. Refer to [EM-13, "Removal and Installation"](#).
2. Remove drive belt auto-tensioner and idler pulley.

INSTALLATION

Installation is in the reverse order of removal.

CAUTION:

If there is damage greater than peeled paint, replace drive belt auto-tensioner.

AIR CLEANER FILTER

< PERIODIC MAINTENANCE >

[VQ40DE]

AIR CLEANER FILTER

Exploded View

INFOID:000000011069684

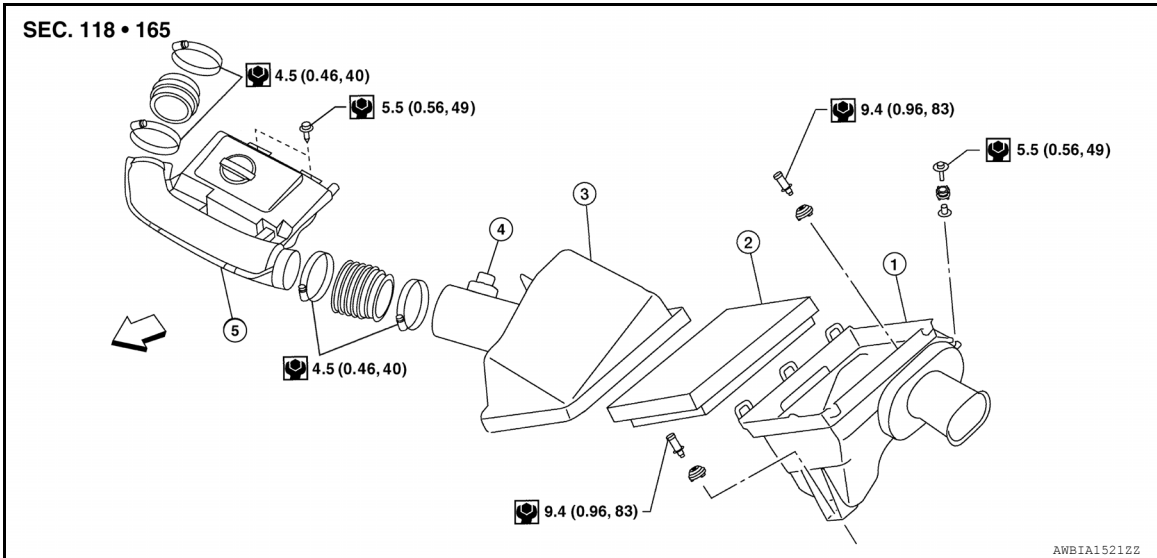

- | | | |
|-----------------------------|---------------------------|-----------------------------|
| 1. Air cleaner case (lower) | 2. Air cleaner filter | 3. Air cleaner case (upper) |
| 4. Mass air flow sensor | 5. Air duct and resonator | ⇐ Front |

Removal and Installation

INFOID:000000011069685

REMOVAL

1. Disconnect air duct and resonator from the air cleaner case (upper).
2. Disconnect mass air flow sensor.
3. Unhook clips, and lift air cleaner case (upper).
4. Remove air cleaner filter.

INSTALLATION

Installation is in the reverse order of removal.

SPARK PLUG

< PERIODIC MAINTENANCE >

[VQ40DE]

SPARK PLUG

Exploded View

INFOID:000000011069686

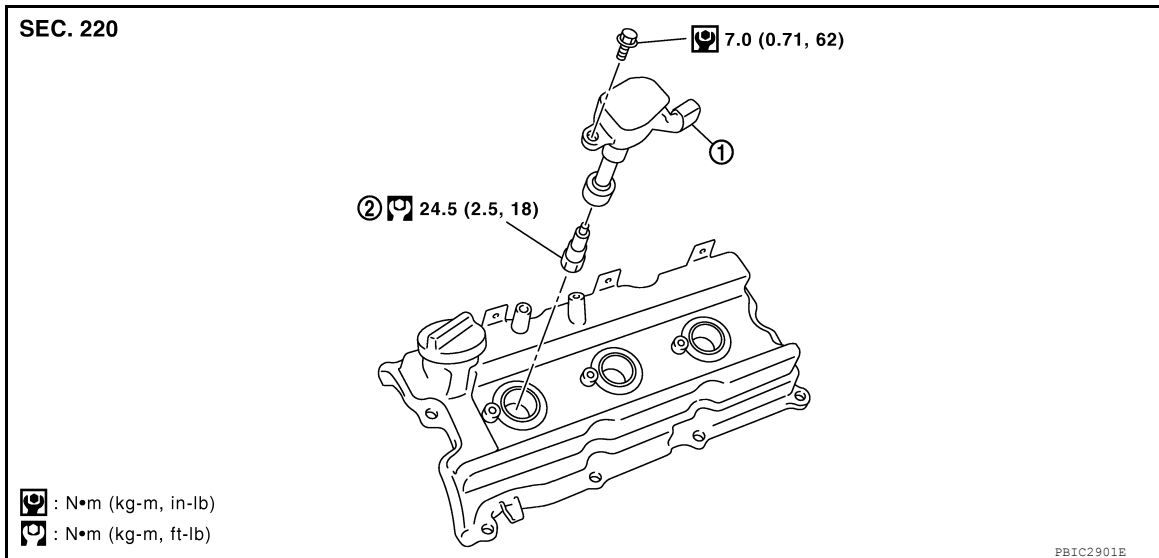

1. Ignition coil

2. Spark plug

Removal and Installation

INFOID:000000011069687

REMOVAL

1. Remove the ignition coil. Refer to [EM-40, "Removal and Installation"](#).
2. Remove the spark plug using a suitable tool.

CAUTION:
Do not drop or shock it.

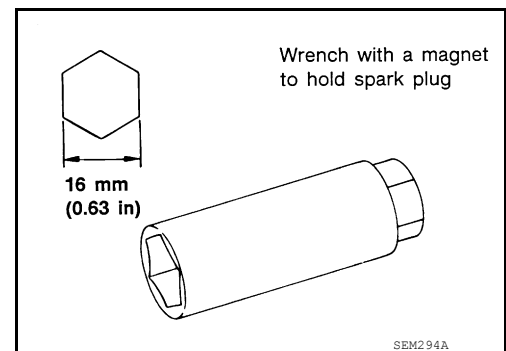

INSPECTION AFTER REMOVAL

- Do not use a wire brush for cleaning.

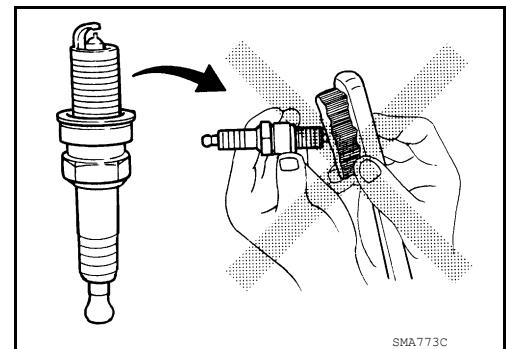

- If the spark plug tip is covered with carbon, spark plug cleaner may be used.

SPARK PLUG

< PERIODIC MAINTENANCE >

[VQ40DE]

Cleaner air pressure : Less than 588 kPa (6 kg/cm², 85 psi)

Cleaning time : Less than 20 seconds

- Checking and adjusting spark plug gap is not required between change intervals.

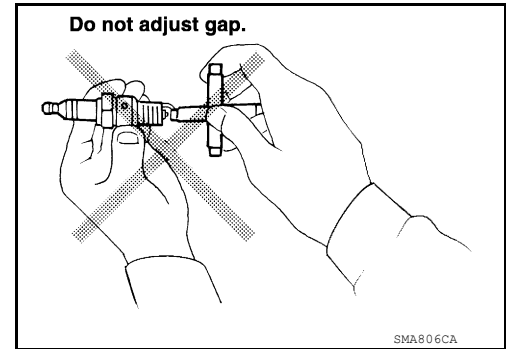

INSTALLATION

Installation is in the reverse order of removal.

CAUTION:

Do not drop or shock the spark plug.

Make	NGK
Standard type*	DILFR5A-11
Gap (nominal)	1.1 mm (0.043 in)

*Always check with the Parts Department for the latest parts information.

A
EM
C
D
E
F
G
H
I
J
K
L
M
N
O
P

CAMSHAFT VALVE CLEARANCE

< PERIODIC MAINTENANCE >

[VQ40DE]

CAMSHAFT VALVE CLEARANCE

Valve Clearance

INFOID:000000011069688

INSPECTION

NOTE:

Perform the following inspection after removal, installation or replacement of camshaft or valve-related parts, or if there are unusual engine conditions due to changes in valve clearance over time (starting, idling, and/or noise).

1. Remove the air cleaner and air duct assembly. Refer to [EM-24, "Exploded View"](#).
2. Remove rocker covers (RH and LH banks). Refer to [EM-41, "Removal and Installation"](#).
3. Measure the valve clearance as follows:
 - a. Set No. 1 cylinder at TDC of its compression stroke.
 - Rotate crankshaft pulley clockwise to align timing mark (A) (grooved line without color) with timing indicator (B).

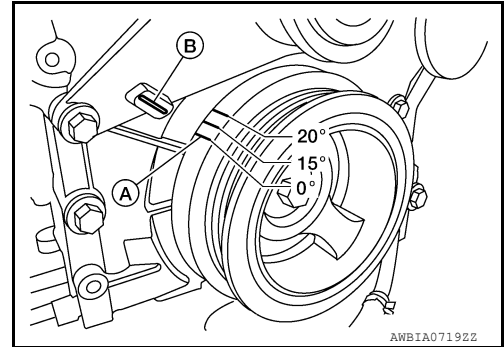

- Make sure that intake and exhaust cam noses on No. 1 cylinder (engine front side of RH bank) are located as shown.
- If not, rotate crankshaft one revolution (360°) and align as shown.

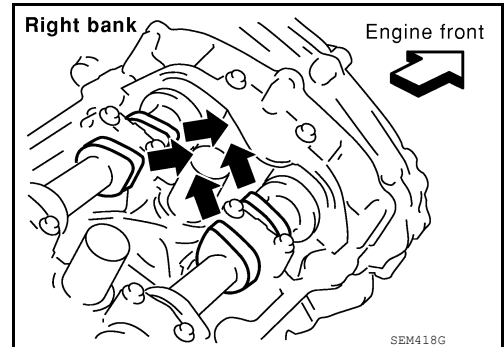

- b. Use feeler gauge to measure the clearance between valve lifter and camshaft.

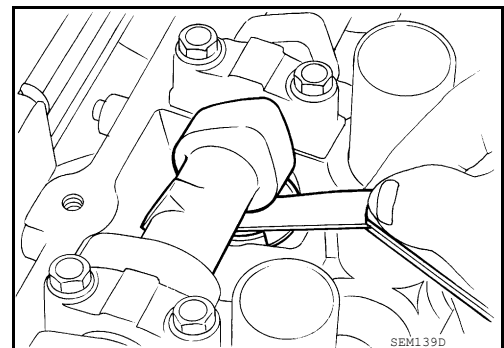

Unit: mm (in)

Valve Clearance	Cold ¹ (reference data)	Hot ² (reference data)
Intake	0.26 - 0.34 (0.010 - 0.013)	0.304 - 0.416 (0.012 - 0.016)
Exhaust	0.29 - 0.37 (0.011 - 0.015)	0.308 - 0.432 (0.012 - 0.017)

¹: Approximately 20°C (68°F)

²: Approximately 80°C (176°F)

CAMSHAFT VALVE CLEARANCE

< PERIODIC MAINTENANCE >

[VQ40DE]

- Measure the valve clearances at locations marked “x” as shown in the table below (locations indicated in the illustration) with feeler gauge.
- No. 1 cylinder at compression TDC

Measuring position (RH bank)		No. 1 CYL.	No. 3 CYL.	No. 5 CYL.
No. 1 cylinder at compression TDC	EXH		x	
	INT	x		
Measuring position (LH bank)		No. 2 CYL.	No. 4 CYL.	No. 6 CYL.
No. 1 cylinder at compression TDC	INT			x
	EXH	x		

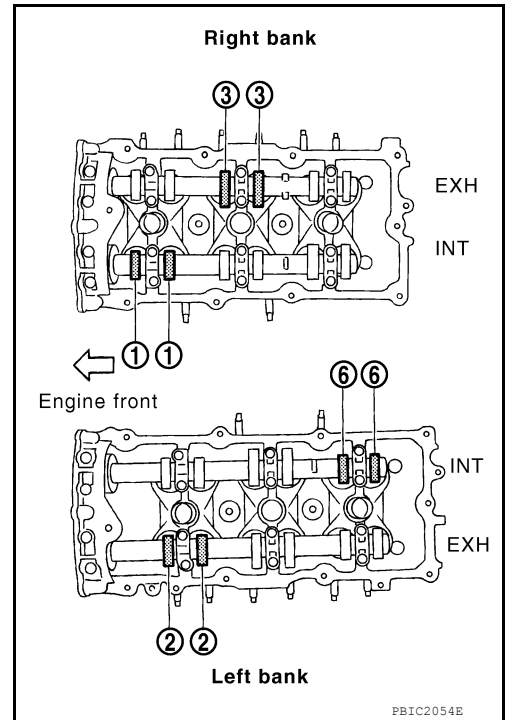

- c. Rotate crankshaft by 240° clockwise (when viewed from engine front) to align No. 3 cylinder at TDC of its compression stroke.

NOTE:

Crankshaft pulley bolt flange has a stamped line every 60°. They can be used as a guide to rotation angle.

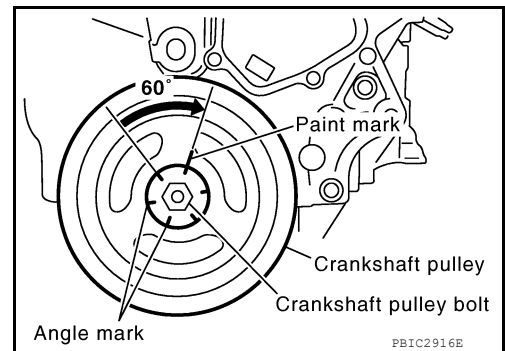

- Measure the valve clearances at locations marked “x” as shown in the table below (locations indicated in the illustration) with feeler gauge.
- No. 3 cylinder at compression TDC

Measuring position (RH bank)		No. 1 CYL.	No. 3 CYL.	No. 5 CYL.
No. 3 cylinder at compression TDC	EXH			x
	INT		x	
Measuring position (LH bank)		No. 2 CYL.	No. 4 CYL.	No. 6 CYL.
No. 3 cylinder at compression TDC	INT	x		
	EXH		x	

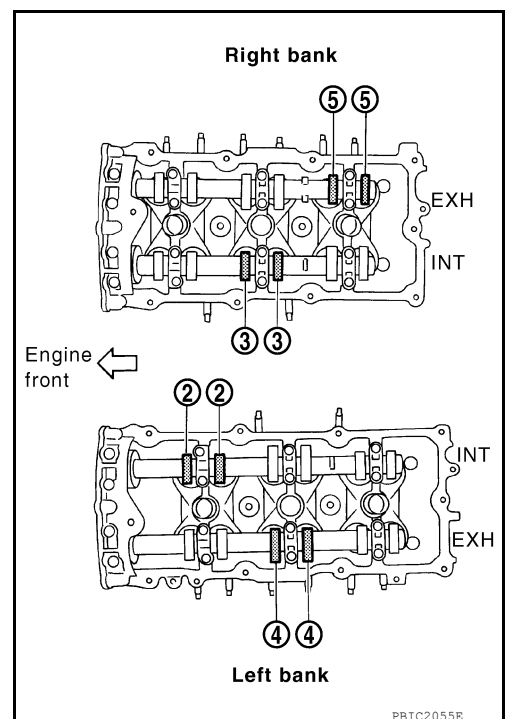

A
EM
C
D
E
F
G
H
I
J
K
L
M
N
O
P

CAMSHAFT VALVE CLEARANCE

[VQ40DE]

< PERIODIC MAINTENANCE >

- d. Rotate crankshaft by 240° clockwise (when viewed from engine front) to align No. 5 cylinder at TDC of compression stroke.

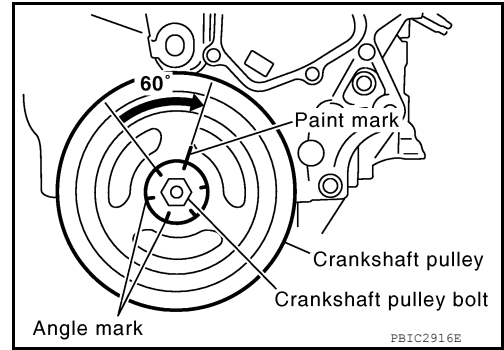

- Measure the valve clearances at locations marked “x” as shown in the table below (locations indicated in the illustration) with feeler gauge.
- No. 5 cylinder at compression TDC

Measuring position (RH bank)		No. 1 CYL.	No. 3 CYL.	No. 5 CYL.
No. 5 cylinder at compression TDC	EXH	x		
	INT			x
Measuring position (LH bank)		No. 2 CYL.	No. 4 CYL.	No. 6 CYL.
No. 5 cylinder at compression TDC	INT		x	
	EXH			x

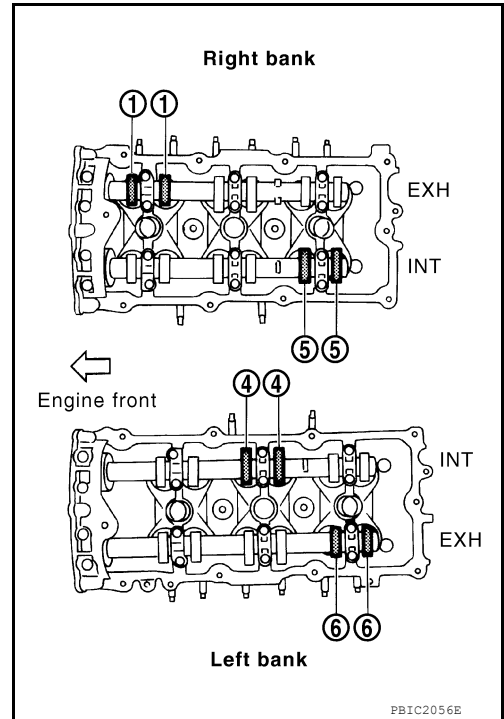

4. For the measured value out of the standard, perform adjustment.

ADJUSTMENT

- Perform adjustment depending on selected head thickness of valve lifter.
1. Measure the valve clearance.
 2. Remove camshaft. Refer to [EM-76. "Removal and Installation"](#).
 3. Remove valve lifters at the locations that are out of the standard.
 4. Measure the center thickness of removed valve lifters with micrometer.

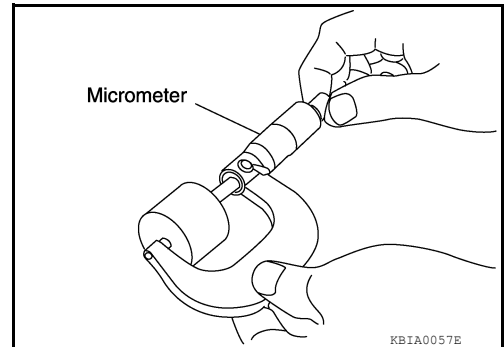

5. Use the equation below to calculate valve lifter thickness for replacement.

CAMSHAFT VALVE CLEARANCE

< PERIODIC MAINTENANCE >

[VQ40DE]

Valve lifter thickness calculation: $t = t_1 + (C_1 - C_2)$

t = Valve lifter thickness to be replaced

t₁ = Removed valve lifter thickness

C₁ = Measured valve clearance

C₂ = Standard valve clearance:

Intake : 0.26 - 0.34 mm (0.010 - 0.013 in)*

Exhaust : 0.29 - 0.37 mm (0.011 - 0.015 in)*

*: Approximately 20°C (68°F)

- Thickness of new valve lifter can be identified by stamp marks on the reverse side (inside the cylinder).

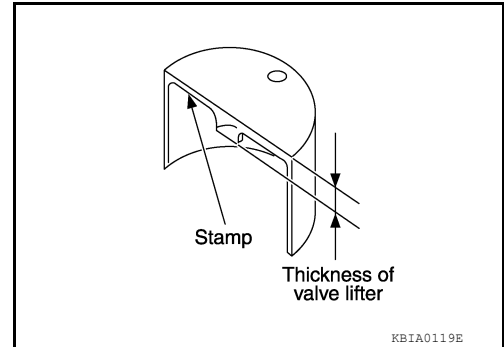

Intake

Stamp mark	Thickness
788U	7.88 mm (0.3102 in)
790U	7.90 mm (0.3110 in)
.	.
.	.
840U	8.40 mm (0.3307 in)

Available thickness of valve lifter: 27 sizes with range 7.88 to 8.40 mm (0.3102 to 0.3307 in) in steps of 0.02 mm (0.0008 in) (when manufactured at factory). Refer to [EM-130, "Standard and Limit"](#).

Exhaust

Stamp mark	Thickness
N788	7.88 mm (0.3102 in)
N790	7.90 mm (0.3110 in)
.	.
.	.
N836	8.36 mm (0.3291 in)

Available thickness of valve lifter: 25 sizes with range 7.88 to 8.36 mm (0.3102 to 0.3291 in) in steps of 0.02 mm (0.0008 in) (when manufactured at factory). Refer to [EM-130, "Standard and Limit"](#).

CAUTION:

Install identification letter at the end and top, "U" and "N", at each of proper positions. (Be careful of mis-installation between intake and exhaust.)

- Install selected valve lifter.
- Install camshaft. Refer to [EM-76, "Removal and Installation"](#).
- Manually turn crankshaft pulley a few turns.
- Make sure that the valve clearances for cold engine are within the specifications by referring to the specified values.
- Installation of the remaining components is in the reverse order of removal.
- Start the engine, and check for unusual noise and vibration.

COMPRESSION PRESSURE

Compression Pressure

INFOID:000000011069689

CHECKING COMPRESSION PRESSURE

1. Warm up engine thoroughly.
2. Release fuel pressure. Refer to [EC-502, "Fuel Pressure Check"](#).
3. Disconnect fuel pump fuse to avoid fuel injection during measurement.

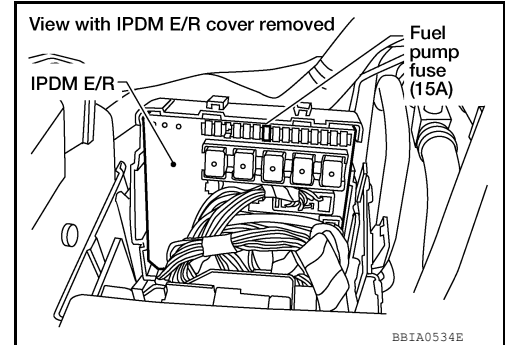

4. Remove intake manifold collector. Refer to [EM-25, "Removal and Installation"](#).
5. Remove spark plug from each cylinder. Refer to [EM-16, "Removal and Installation"](#).
6. Connect engine tachometer (not required in use of CONSULT).
7. Install compression tester with adapter onto spark plug hole.

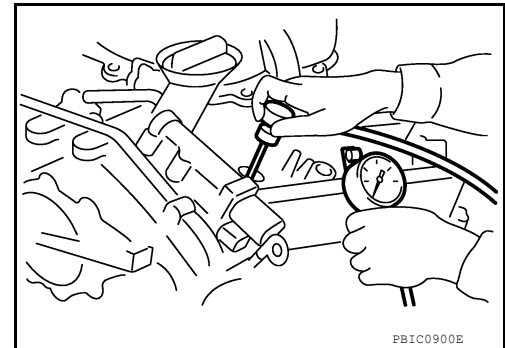

- Use compression gauge whose pick up end inserted to spark plug hole is smaller than 20 mm (0.79 in) in diameter. Otherwise, it may be caught by cylinder head during removal.

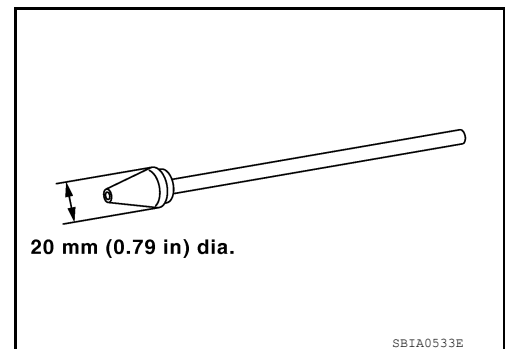

8. Turn ignition switch to "START" for cranking. When the gauge pointer stabilizes, read the compression pressure and engine rpm. Perform these steps to check each cylinder.

Compression pressure:

Unit: kPa (kg/cm², psi) /rpm

Standard	Minimum	Differential limit between cylinders
1,275 (13.0, 185) / 300	981 (10.0, 142) / 300	98 (1.0, 14) / 300

CAUTION:

Always use a fully charged battery to obtain specified engine speed.

- If the engine speed is out of the specified range check the battery and recharge as necessary. Check the engine speed again with the battery properly charged.

COMPRESSION PRESSURE

[VQ40DE]

< PERIODIC MAINTENANCE >

- If some cylinders have low compression pressure, pour a small amount of engine oil into the spark plug hole of the cylinder to re-check it for compression.
 - If the added engine oil improves the compression, piston rings may be worn out or damaged. Check the piston rings and replace if necessary
 - If the compression pressure remains at low level despite the addition of engine oil, the valves may be malfunctioning. Check the valves for damage. Replace the valve or valve seat accordingly.
 - If two adjacent cylinders have respectively low compression pressure and their compression remains low even after the addition of engine oil, cylinder head gaskets may be leaking, or a valve in adjacent cylinders may be damaged. Inspect and repair as required.
 - If the compression pressure is below the minimum value, check the valve clearances and parts associated with the combustion chamber (valve, valve seat, piston, piston ring, cylinder bore, cylinder head, cylinder head gasket). After the checking, measure the compression pressure again.
9. Install the components in the reverse order of removal.
 10. Start the engine, and confirm that it runs smoothly.
 11. Perform trouble diagnosis. If DTC appears, erase it. Refer to [EC-143, "Description"](#).

A

EM

C

D

E

F

G

H

I

J

K

L

M

N

O

P

AIR CLEANER AND AIR DUCT

< REMOVAL AND INSTALLATION >

[VQ40DE]

REMOVAL AND INSTALLATION

AIR CLEANER AND AIR DUCT

Exploded View

INFOID:000000011069690

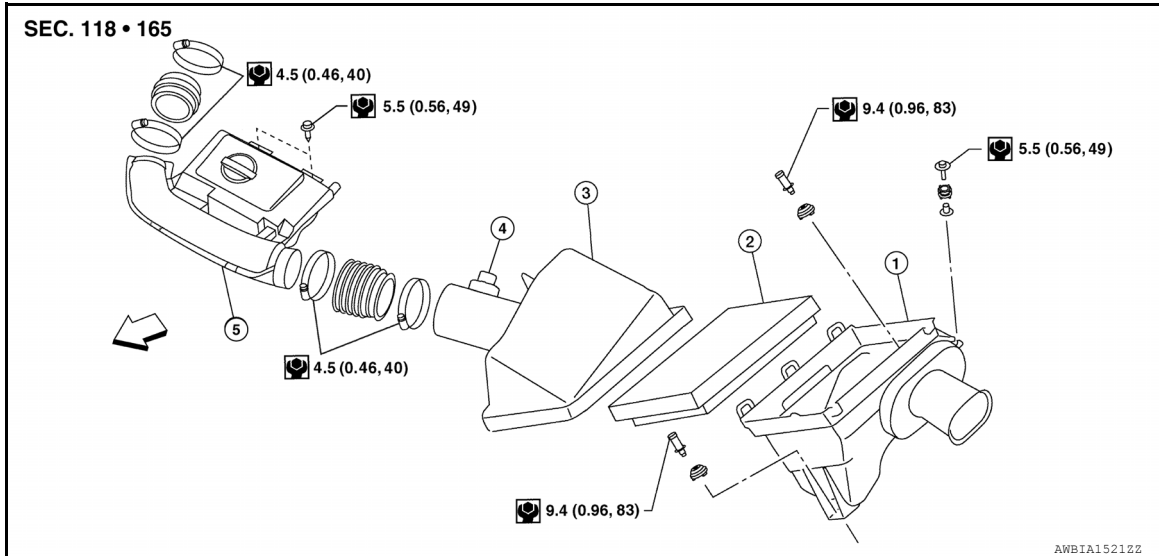

1. Air cleaner case (lower)
 2. Air cleaner filter
 3. Air cleaner case (upper)
 4. Mass air flow
 5. Air duct and resonator
- ⇐ Front

Removal and Installation

INFOID:000000011069691

NOTE:

Add marks as necessary for easier installation.

REMOVAL

1. Disconnect the harness connector from mass air flow sensor.
2. Disconnect crankcase ventilation hose.
3. Remove the air duct and resonator assembly and air cleaner case (upper).
4. Remove air cleaner filter and air cleaner case (lower).
5. If necessary remove the mass air flow sensor from the air cleaner case (upper)

CAUTION:

Handle mass air flow sensor with care.

- Do not shock it.
- Do not disassemble it.
- Do not touch its sensor.

INSPECTION AFTER REMOVAL

Inspect air duct and resonator assembly for cracks or tears.

- Replace air duct and resonator assembly as necessary.

INSTALLATION

Installation is in the reverse order of removal.

INTAKE MANIFOLD COLLECTOR

< REMOVAL AND INSTALLATION >

[VQ40DE]

INTAKE MANIFOLD COLLECTOR

Exploded View

INFOID:000000011069692

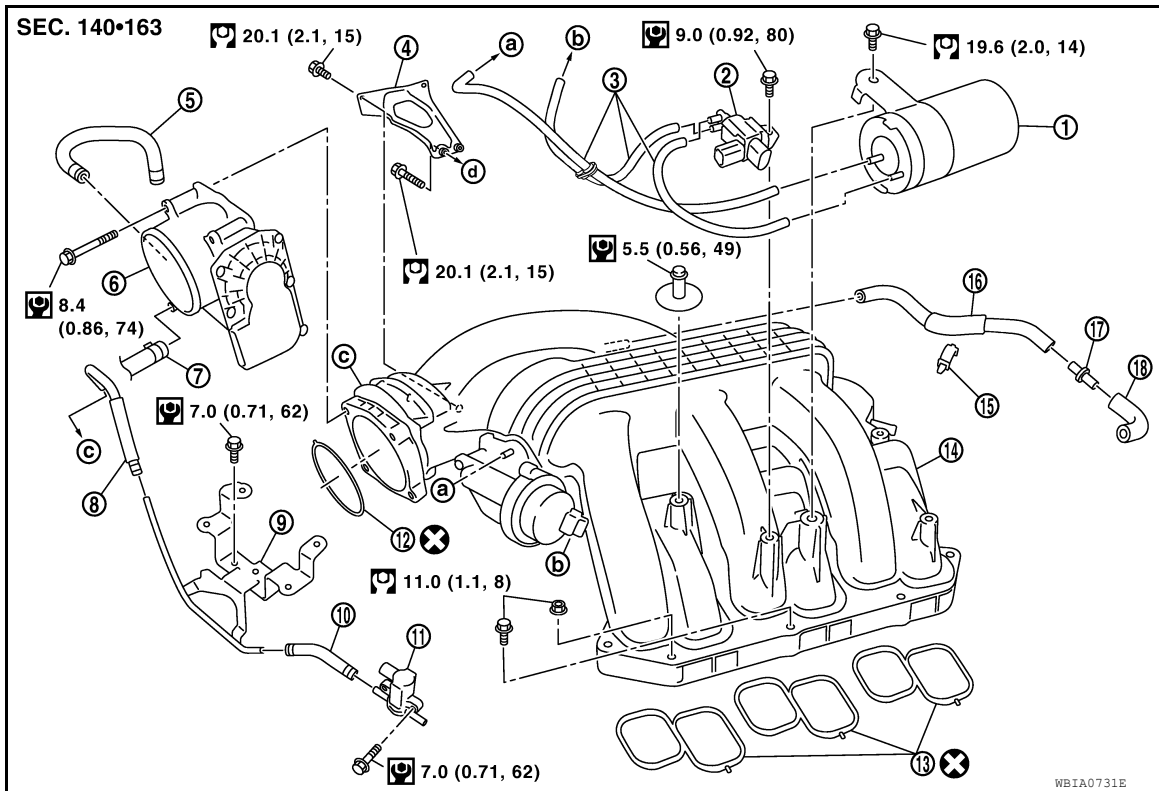

- | | | |
|--------------------------------------|-------------------------------------------------------|---------------------------------------|
| 1. Vacuum tank | 2. VIAS control solenoid valve | 3. Vacuum hose |
| 4. Intake manifold collector support | 5. Water hose | 6. Electric throttle control actuator |
| 7. Water hose | 8. EVAP hose | 9. Bracket |
| 10. EVAP hose | 11. EVAP canister purge volume control solenoid valve | 12. Gasket |
| 13. Gasket | 14. Intake manifold collector | 15. Clip |
| 16. PCV hose | 17. Connector | 18. PCV hose |
| a. To intake manifold collector | b. To power valve | c. To throttle body |
| d. To cylinder head (RH bank) | | |

Removal and Installation

INFOID:000000011069693

NOTE:

When removing components such as hoses, tubes/lines, etc., cap or plug openings to prevent fluid from spilling.

REMOVAL

1. Remove air duct and resonator assembly. Refer to [EM-24, "Removal and Installation"](#).
2. Remove electric throttle control actuator as follows:
 - a. Partially drain engine coolant. Refer to [CO-11, "Changing Engine Coolant"](#).

WARNING:

To avoid the danger of being scalded, do not drain engine coolant when engine is hot.

CAUTION:

- Perform when engine is cold.
 - Do not spill engine coolant on drive belt.
- b. Disconnect water hoses from electric throttle control actuator.
 - c. Disconnect harness connector.

INTAKE MANIFOLD COLLECTOR

[VQ40DE]

< REMOVAL AND INSTALLATION >

d. Loosen bolts in reverse order as shown.

CAUTION:

- Handle carefully to avoid any shock to electric throttle control actuator.
- Do not disassemble.

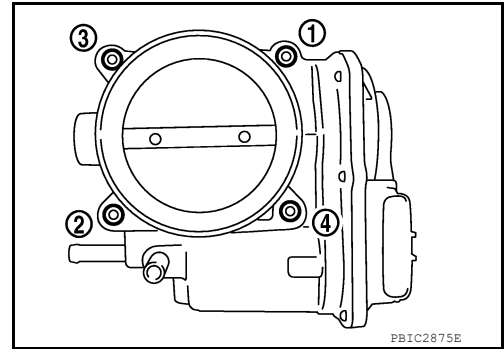

3. Remove the following parts:

- Vacuum hose (to brake booster)
- PCV hose

4. Loosen the intake manifold collector support bolts in reverse order as shown to remove the intake manifold collector support.

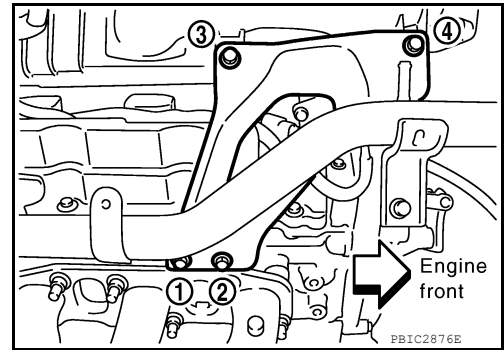

5. Disconnect EVAP hoses and harness connector from EVAP canister purge volume control solenoid valve.
6. Remove EVAP canister purge volume control solenoid valve.
7. Remove VIAS control solenoid valve and vacuum tank.
- Add mating marks as necessary for easier installation.
8. Loosen nuts and bolts in reverse order as shown with power tool, and remove intake manifold collector.

CAUTION:

Cover engine openings to avoid entry of foreign materials.

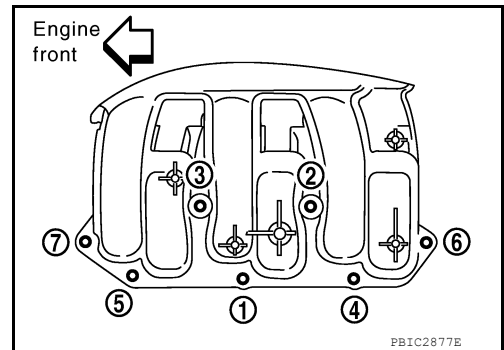

INSTALLATION

Installation is in the reverse order of removal. Note the following:

Intake Manifold Collector

- If stud bolts were removed from intake manifold, install them and tighten to the specified torque.

Intake manifold collector stud bolts : 6.9 N·m (0.7 kg-m, 61 in-lb)

INTAKE MANIFOLD COLLECTOR

< REMOVAL AND INSTALLATION >

[VQ40DE]

- Tighten nuts and bolts in numerical order as shown.

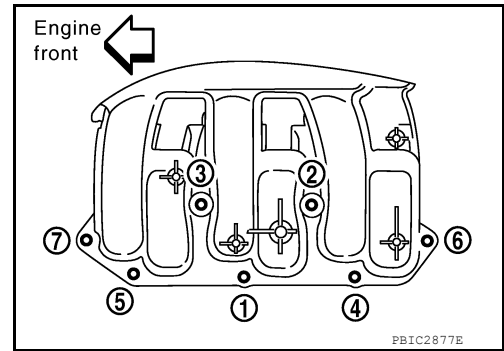

Intake Manifold Collector Support

Tighten the intake manifold collector support bolts to specification in the order as shown to install the intake manifold collector support.

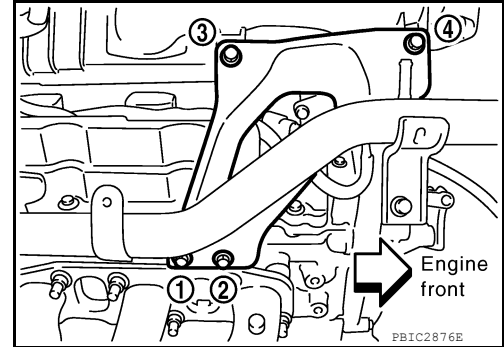

Electric Throttle Control Actuator

- Tighten bolts in numerical order as shown.
- Perform the "Throttle Valve Closed Position Learning" when harness connector of electric throttle control actuator is disconnected. Refer to [EC-127, "Throttle Valve Closed Position Learning"](#).
- Perform the "Idle Air Volume Learning" and "Throttle Valve Closed Position Learning" when electric throttle control actuator is replaced. Refer to [EC-127, "Idle Air Volume Learning"](#).

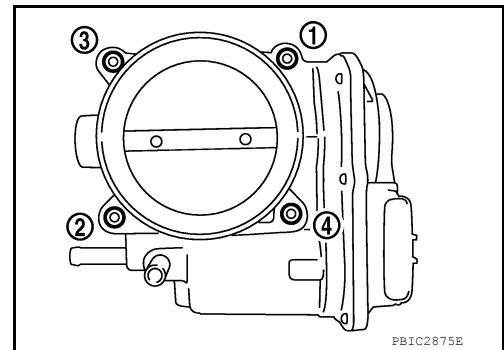

A
EM
C
D
E
F
G
H
I
J
K
L
M
N
O
P

INTAKE MANIFOLD

< REMOVAL AND INSTALLATION >

[VQ40DE]

INTAKE MANIFOLD

Exploded View

INFOID:000000011069694

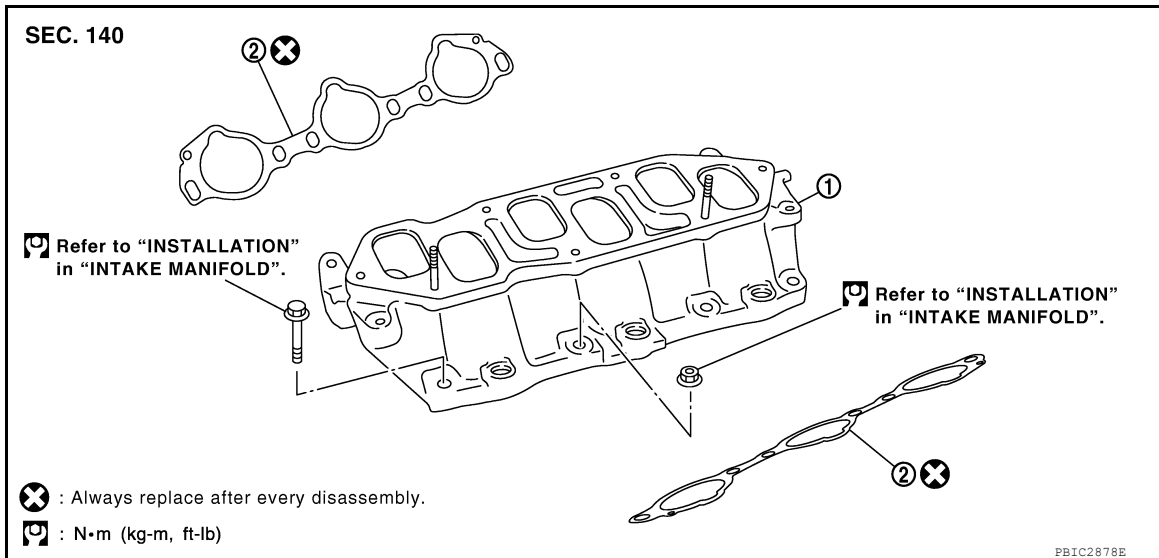

1. Intake manifold

2. Gasket

Removal and Installation

INFOID:000000011069695

NOTE:

When removing components such as hoses, tubes/lines, etc., cap or plug openings to prevent fluid from spilling.

REMOVAL

1. Remove intake manifold collector. Refer to [EM-25, "Removal and Installation"](#).
2. Remove fuel tube and fuel injector assembly. Refer to [EM-45, "Removal and Installation"](#).
3. Loosen nuts and bolts with power tool in reverse order as shown to remove intake manifold.

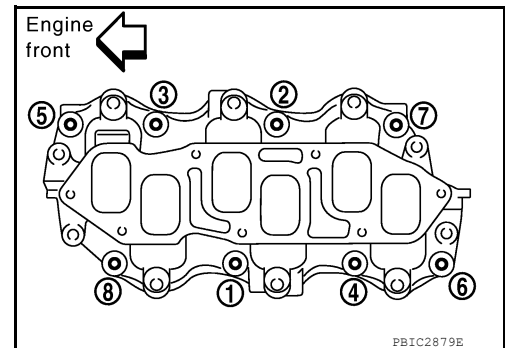

4. Remove gaskets.

CAUTION:

Cover engine openings to avoid entry of foreign materials.

INSPECTION AFTER REMOVAL

Surface Distortion

INTAKE MANIFOLD

[VQ40DE]

< REMOVAL AND INSTALLATION >

- Check the surface distortion of the intake manifold mating surface with straightedge and feeler gauge.

Limit : 0.1 mm (0.004 in)

- If it exceeds the limit, replace intake manifold.

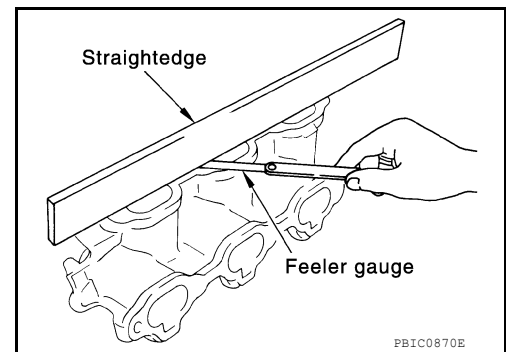

INSTALLATION

Installation is in the reverse order of removal. Note the following:

Intake Manifold

- If stud bolts were removed from cylinder head, install them and tighten to the specified torque.

Intake manifold studs : 10.8 N·m (1.1 kg-m, 8 ft-lb)

- Tighten all nuts and bolts to the specified torque in two or more steps in numerical order as shown.

Intake manifold bolt and nuts

1st step : 7.4 N·m (0.75 kg-m, 65 in-lb)

2nd step : 29.0 N·m (3.0 kg-m, 21 ft-lb)

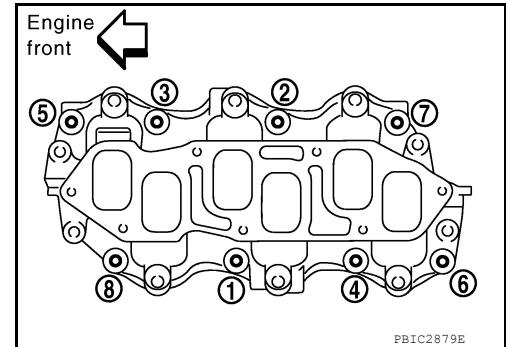

- Adjust neutral position steering angle sensor.
- Erase CPU memory.
- Perform the "Throttle Valve Closed Position Learning" when harness connector of electric throttle control actuator is disconnected. Refer to [EC-127, "Throttle Valve Closed Position Learning"](#).
- Perform the "Idle Air Volume Learning" and "Throttle Valve Closed Position Learning" when electric throttle control actuator is replaced. Refer to [EC-127, "Idle Air Volume Learning"](#).

EXHAUST MANIFOLD AND THREE WAY CATALYST

< REMOVAL AND INSTALLATION >

[VQ40DE]

EXHAUST MANIFOLD AND THREE WAY CATALYST

Exploded View

INFOID:000000011069696

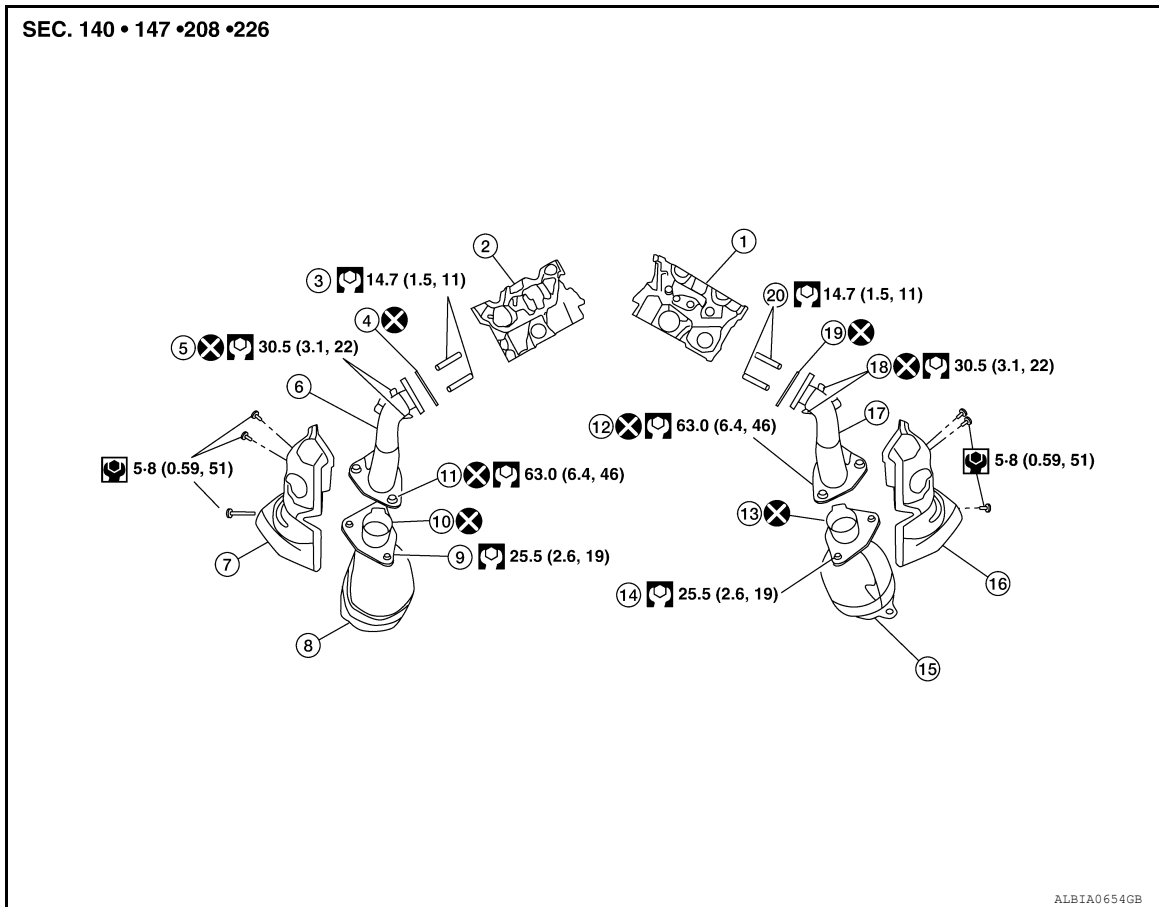

- | | | |
|---------------------------------|-----------------------------------|----------------------------------|
| 1. Cylinder head (LH) | 2. Cylinder head (RH) | 3. Exhaust manifold studs (RH) |
| 4. Gasket | 5. Exhaust manifold nuts (RH) | 6. Exhaust manifold (RH) |
| 7. Exhaust manifold cover (RH) | 8. Three way catalyst (RH) | 9. Three way catalyst studs (RH) |
| 10. Seal ring | 11. Three way catalyst nuts (RH) | 12. Three way catalyst nuts (LH) |
| 13. Seal ring | 14. Three way catalyst studs (LH) | 15. Three way catalyst (LH) |
| 16. Exhaust manifold cover (LH) | 17. Exhaust manifold (LH) | 18. Exhaust manifold nuts (LH) |
| 19. Gasket | 20. Exhaust manifold studs (LH) | |

Removal and Installation (Three Way Catalyst)

INFOID:000000011069697

WARNING:

Perform the work when the exhaust and cooling system have cooled sufficiently.

REMOVAL

1. Remove the front wheel and tire. Refer to [WT-48. "Adjustment"](#).
2. Remove the mudguard (if equipped) and front fender protector. Refer to [EXT-22. "Removal and Installation"](#).
3. Remove the exhaust manifold cover bolts.
4. Remove the center exhaust tube, main muffler and front exhaust tube. Refer to [EX-5. "Exploded View"](#).
5. Disconnect the harness connector from air fuel ratio sensor.
6. Remove the three way catalyst nuts and remove the three way catalyst.
7. Remove the air fuel ratio sensor 1 using Tool, if necessary.

EXHAUST MANIFOLD AND THREE WAY CATALYST

< REMOVAL AND INSTALLATION >

[VQ40DE]

Tool number : KV991J0050 (J-44626)

CAUTION:

- Be careful not to damage air fuel ratio sensor 1.
- Discard any air fuel ratio sensor 1 which has been dropped from a height of more than 0.5 m (19.7 in) onto a hard surface such as a concrete floor; replace with a new sensor.

INSTALLATION

Installation is in the reverse order of removal.

- Tighten air fuel ratio sensor 1 to specification, if removed.

Air fuel ratio sensor : 50.0 N·m (5.1 kg-m, 37 ft-lb)

CAUTION:

- Do not over tighten air fuel ratio sensor 1. Doing so may cause damage to air fuel ratio sensor 1, resulting in the "MIL" coming on.
- Before installing a new air fuel ratio sensor 1, clean exhaust system threads using oxygen sensor thread cleaner and apply anti-seize lubricant.

Oxygen sensor thread cleaner : — (J-43897-12)

Oxygen sensor thread cleaner : — (J-43897 18)

Removal and Installation (Exhaust Manifold)

INFOID:000000011069698

REMOVAL (LH)

WARNING:

Perform the work when the exhaust and cooling system have cooled sufficiently.

NOTE:

When removing components such as hoses, tubes/lines, etc., cap or plug openings to prevent fluid from spilling.

1. Remove air cleaner case (upper) and air duct and resonator assembly. Refer to [EM-24, "Exploded View"](#).
2. Partially drain engine coolant. Refer to [CO-11, "Changing Engine Coolant"](#).
3. Remove three way catalyst (LH). Refer to [EM-30, "Removal and Installation \(Three Way Catalyst\)"](#).
4. Remove oil level gauge and oil level gauge guide. Refer to [EM-34, "Exploded View"](#).
5. Disconnect water hoses at heater pipe. Refer to [CO-28, "Exploded View"](#).
6. Remove heater pipe from cylinder head (LH). Refer to [CO-28, "Exploded View"](#).
7. Loosen nuts in reverse order as shown.

- ←: Front

NOTE:

Disregard the numerical order No. 7 and 8 in removal.

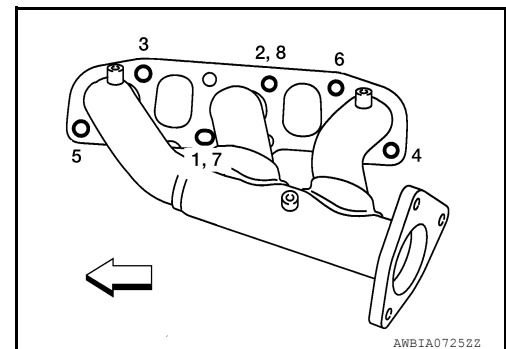

8. Remove exhaust manifold (LH).
9. Remove gaskets.

CAUTION:

Cover engine openings to avoid entry of foreign materials.

INSPECTION AFTER REMOVAL (LH)

Surface Distortion

EXHAUST MANIFOLD AND THREE WAY CATALYST

[VQ40DE]

< REMOVAL AND INSTALLATION >

- Check the surface distortion of the exhaust manifold mating surface with straightedge and feeler gauge.

Limit : 0.3 mm (0.012 in)

- If it exceeds the limit, replace exhaust manifold.

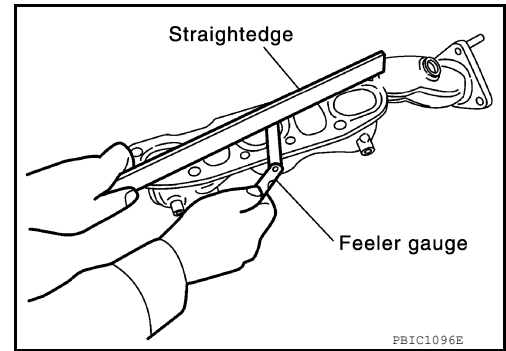

INSTALLATION (LH)

Installation is in the reverse order of removal.

Exhaust Manifold Gasket

Install the exhaust manifold gasket in direction as shown.

- ←: Front
- A: Identification hole

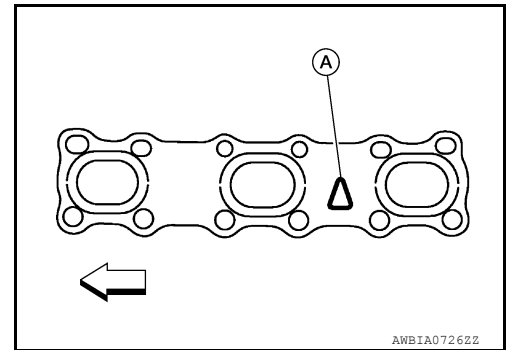

Exhaust Manifold

- If exhaust manifold studs were removed, install them and tighten to specification.
- Install exhaust manifold and tighten nuts in numerical order as shown.

CAUTION:

Use new exhaust manifold nuts for installation.

NOTE:

Tighten nuts No. 1 and 2 in two steps. The numerical order No. 7 and 8 show second step.

- ←: Front

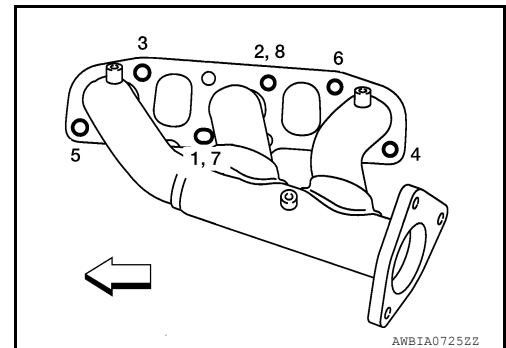

REMOVAL (RH)

1. Remove three way catalyst (RH). Refer to [EM-30, "Removal and Installation \(Three Way Catalyst\)"](#).
2. Remove heat shield from lower dash panel.
3. Remove support bolts from A/T fluid charging pipe (A/T models). Refer to [TM-250, "Removal and Installation \(2WD\)"](#) (2WD models), or [TM-252, "Removal and Installation \(4WD\)"](#) (4WD models).
4. Loosen nuts in reverse order as shown.

- ←: Front

NOTE:

Disregard the numerical order No. 7 and 8 in removal.

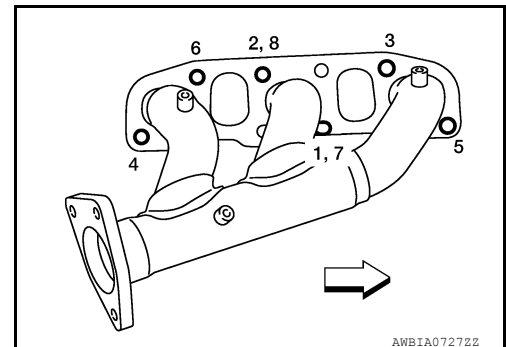

5. Remove exhaust manifold (RH) and exhaust manifold cover (RH) together.

EXHAUST MANIFOLD AND THREE WAY CATALYST

< REMOVAL AND INSTALLATION >

[VQ40DE]

6. Remove gaskets.

CAUTION:

Cover engine openings to avoid entry of foreign materials.

INSPECTION AFTER REMOVAL (RH)

Surface Distortion

- Check the surface distortion of the exhaust manifold mating surface with straightedge and feeler gauge.

Limit : 0.3 mm (0.012 in)

- If it exceeds the limit, replace exhaust manifold.

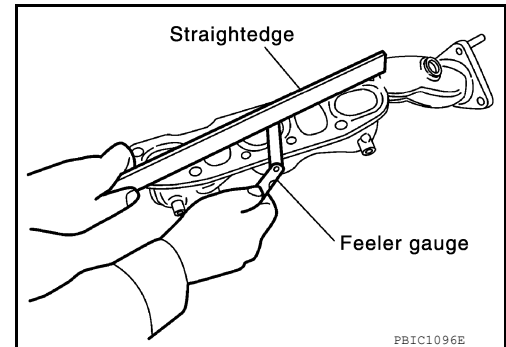

INSTALLATION (RH)

Installation is in the reverse order of removal.

NOTE:

If necessary, a crowfoot may be used to tighten the exhaust manifold nuts.

Exhaust Manifold Gasket

Install the exhaust manifold gaskets in direction as shown.

- ⇐: Front
- A: Identification hole

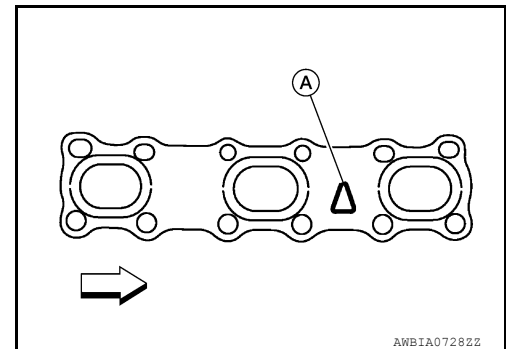

Exhaust Manifold

- If exhaust manifold studs were removed, install them and tighten to specification.
- Install exhaust manifold and tighten nuts in numerical order as shown.

CAUTION:

Use new exhaust manifold nuts for installation.

NOTE:

Tighten nuts No. 1 and 2 in two steps. The numerical order No. 7 and 8 show second step.

- ⇐: Front

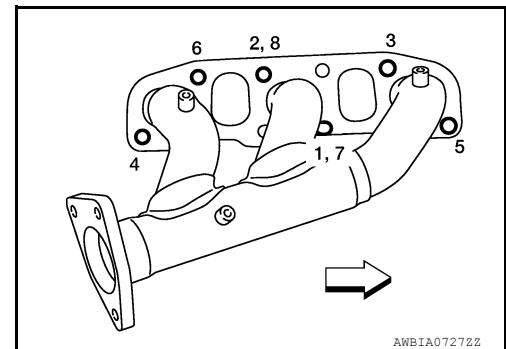

OIL PAN AND OIL STRAINER

< REMOVAL AND INSTALLATION >

[VQ40DE]

OIL PAN AND OIL STRAINER

Exploded View

INFOID:000000011069699

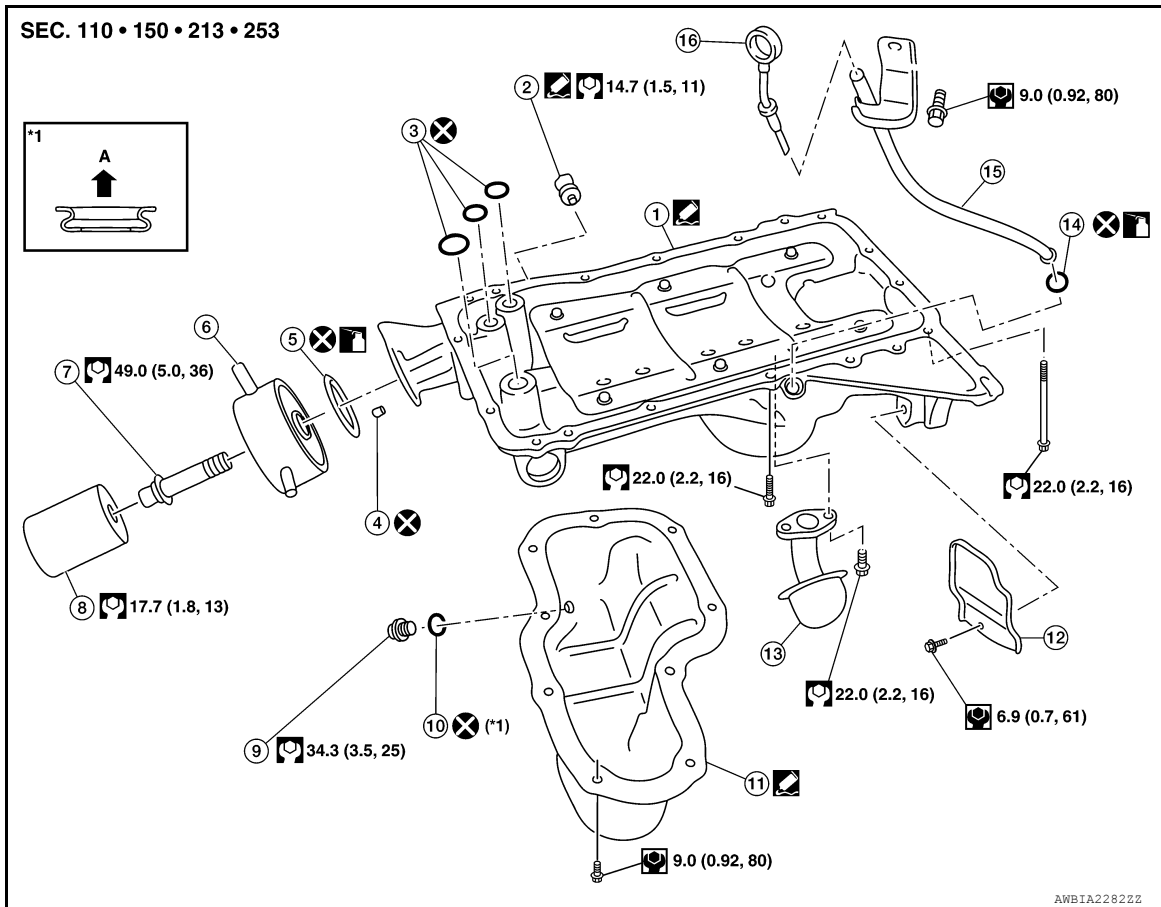

AWBIA2292Z

- | | | |
|-----------------------|------------------------|---------------------------|
| 1. Oil pan (upper) | 2. Oil pressure switch | 3. O-ring |
| 4. Relief valve | 5. O-ring | 6. Oil cooler |
| 7. Connector bolt | 8. Oil filter | 9. Drain plug |
| 10. Drain plug washer | 11. Oil pan (lower) | 12. Rear cover plate |
| 13. Oil strainer | 14. O-ring | 15. Oil level gauge guide |
| 16. Oil level gauge | A. Oil pan side | |

Removal and Installation

INFOID:000000011069700

REMOVAL (LOWER)

WARNING:

To avoid the danger of being scalded, do not drain engine oil when engine is hot.

1. Remove engine under cover. (If equipped)
2. Drain engine oil. Refer to [LU-8, "Changing Engine Oil"](#).
3. Remove oil pan (lower) as follows:

OIL PAN AND OIL STRAINER

[VQ40DE]

< REMOVAL AND INSTALLATION >

- a. Remove the oil pan (lower) bolts using power tool in reverse order as shown.

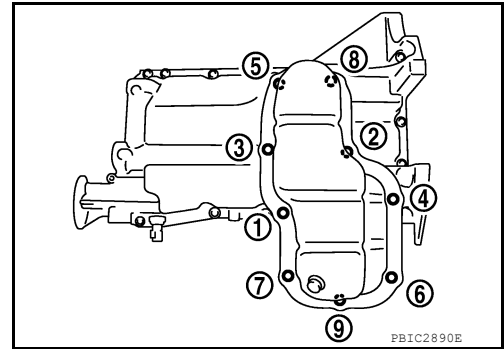

- b. Insert Tool between the oil pan (lower) and the oil pan (upper).

Tool number : KV10111100 (J-37228)

CAUTION:

- Be careful not to damage the mating surfaces.
- Do not insert screwdriver, this will damage the mating surfaces.

NOTE:

Tap (1) Tool to insert it and then slide (2) it by tapping on the side of the Tool as shown.

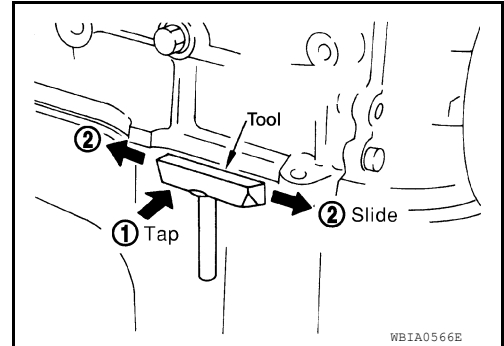

INSPECTION AFTER REMOVAL

Clean oil strainer if any object attached.

INSTALLATION (LOWER)

1. Install oil pan (lower) as follows:

- a. Use scraper to remove old liquid gasket from mating surfaces.
- Also remove old liquid gasket from mating surface of oil pan (upper).
 - Remove old liquid gasket from the bolt holes and thread.

CAUTION:

Do not scratch or damage the mating surfaces when cleaning off old liquid gasket.

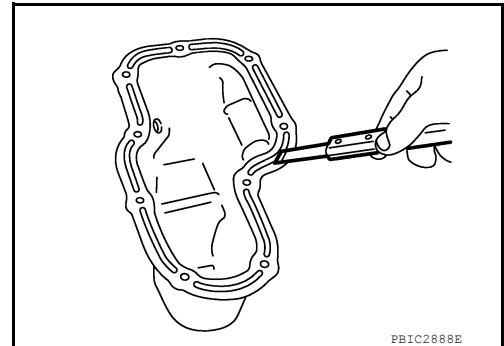

- b. Apply a continuous bead of liquid gasket using suitable tool to the oil pan (lower) as shown.

Use Genuine RTV Silicone Sealant or equivalent. Refer to [GI-21, "Recommended Chemical Products and Sealants"](#).

CAUTION:

Installation should be done within 5 minutes after coating.

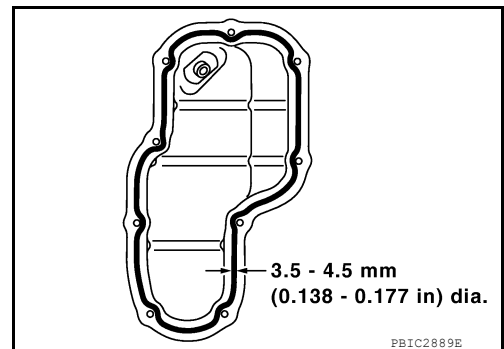

- c. Install oil pan (lower).

OIL PAN AND OIL STRAINER

< REMOVAL AND INSTALLATION >

[VQ40DE]

- Tighten oil pan (lower) bolts in numerical order as shown.

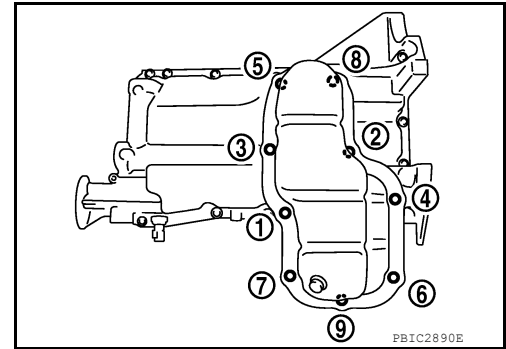

2. Install oil pan drain plug. Refer to [EM-34, "Removal and Installation"](#).
3. After 30 minutes fill with engine oil and inspect for leaks. Refer to [LU-8, "Changing Engine Oil"](#).
CAUTION:
Do not fill the engine with oil for at least 30 minutes after oil pan is installed.
4. Install engine under cover (If equipped).

INSPECTION AFTER INSTALLATION

1. Start engine, and check for engine oil leaks.
2. Stop engine and wait for 10 minutes.
3. Check engine oil level. Refer to [LU-7, "Inspection"](#).

REMOVAL (UPPER)

WARNING:

To avoid the danger of being scalded, do not drain engine oil when engine is hot.

CAUTION:

- Perform this procedure when engine is cold.
- Do not spill engine oil on drive belts.
- Do not spill engine coolant on drive belts.

NOTE:

When removing components such as hoses, tubes/lines, etc., cap or plug openings to prevent fluid from spilling.

1. Remove engine under cover. (If equipped). Refer to [EXT-15, "Removal and Installation"](#).
2. Drain engine coolant. Refer to [CO-11, "Changing Engine Coolant"](#).
3. Remove oil pan (lower). Refer to REMOVAL (LOWER).
4. Reposition the (RH) brake caliper aside and support with a suitable wire without disconnecting the front brake hose (4WD models). Refer to [BR-36, "Removal and Installation of Brake Caliper and Disc Rotor"](#).
5. Remove oil level gauge and oil level gauge guide.
6. Remove front final drive (4WD models). Refer to [DLN-165, "Removal and Installation"](#).
7. Remove front frame crossmember.
8. Disconnect steering gear lower joint shaft bolt and steering gear nuts and bolts, position out of the way. Refer to [ST-15, "Removal and Installation"](#).
9. Remove stabilizer bar brackets and position stabilizer bar out of the way. Refer to [FSU-13, "Component"](#).
10. Disconnect A/T fluid cooler tube brackets and position out of the way (A/T models). Refer to [TM-250, "Removal and Installation \(2WD\)"](#) (2WD models), [TM-252, "Removal and Installation \(4WD\)"](#) (4WD models).
11. Remove oil filter, if necessary. Refer to [LU-10, "Removal and Installation"](#).
12. Disconnect oil cooler hoses. Remove oil cooler, if necessary. Refer to [LU-11, "Removal and Installation"](#).
13. Remove oil cooler, if necessary. Refer to [LU-11, "Removal and Installation"](#).
14. Disconnect oil pressure switch and remove.
15. Remove oil pan (lower).
16. Remove oil strainer.

OIL PAN AND OIL STRAINER

[VQ40DE]

< REMOVAL AND INSTALLATION >

17. Remove transmission joint bolts which pierce oil pan (upper). Refer to [TM-21. "Removal and Installation from Vehicle"](#) (4WD M/T models), [TM-250. "Removal and Installation \(2WD\)"](#) (2WD A/T models), [TM-252. "Removal and Installation \(4WD\)"](#) (4WD A/T models).
18. Remove rear cover plate.
19. Remove oil pan (upper) bolts with power tool in reverse order as shown.

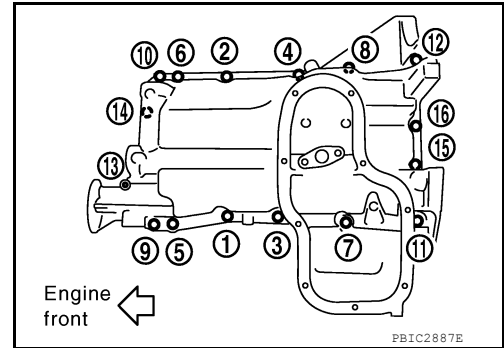

- Insert Tool between oil pan (upper) and lower cylinder block. Tap (1) Tool to insert it and then slide (2) it by tapping on the side as shown.

Tool number : KV10111100 (J-37228)

CAUTION:
Be careful not to damage mating surfaces.

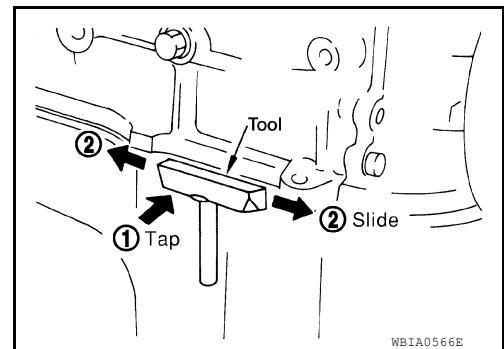

20. Remove O-rings from bottom of lower cylinder block and oil pump.
CAUTION:
 - Do not reuse the three O-rings.
 - Install a new O-ring in the upper oil pan and two new O-rings in the front cover.

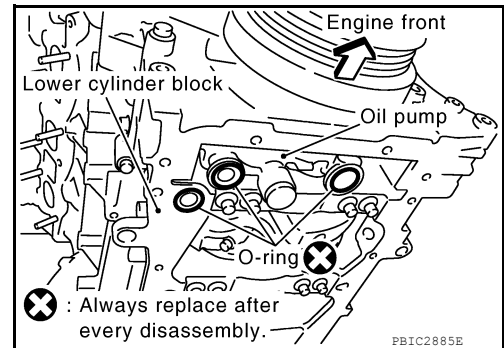

INSPECTION AFTER REMOVAL

Clean oil strainer.

INSTALLATION (UPPER)

1. Install oil pan (upper) as follows:
 - a. Use scraper to remove old liquid gasket from mating surfaces.
 - Also remove the old liquid gasket from mating surface of lower cylinder block.
 - Remove old liquid gasket from the bolt holes and threads.**CAUTION:**
Do not scratch or damage the mating surfaces when cleaning off old liquid gasket.

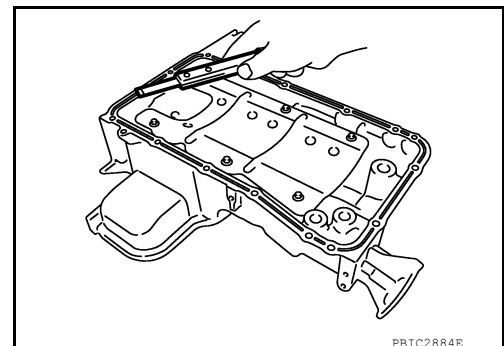

OIL PAN AND OIL STRAINER

[VQ40DE]

< REMOVAL AND INSTALLATION >

- b. Install new O-rings on the bottom of lower cylinder block and oil pump.

CAUTION:

- Do not reuse the three O-rings.
- Install a new O-ring in the upper oil pan and two new O-rings in the front cover.

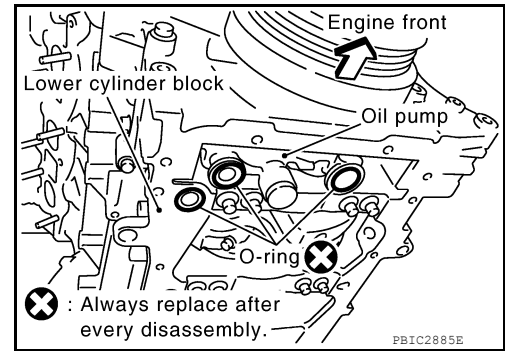

- c. Apply a continuous bead of liquid gasket using suitable tool to the lower cylinder block mating surfaces of oil pan (upper) as shown.

Use Genuine RTV Silicone Sealant or equivalent. Refer to [GI-21, "Recommended Chemical Products and Sealants"](#).

CAUTION:

- For bolt holes with ▲ mark, apply liquid gasket outside the hole.
- Apply a bead of 4.5 to 5.5 mm (0.177 to 0.217 in) in diameter to area (A).
- Installation should be done within 5 minutes after coating.

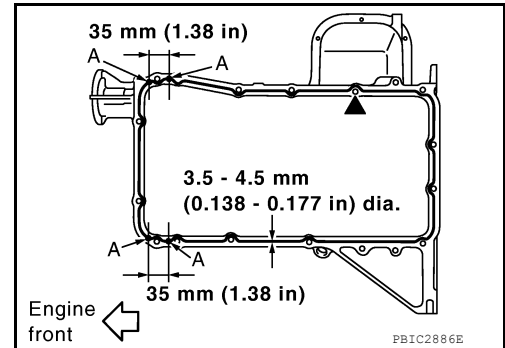

- d. Install oil pan (upper).

CAUTION:

- Do not reuse the three O-rings.
- Install a new O-ring in the upper oil pan and two new O-rings in the front cover.
- Install avoiding misalignment of both oil pan gaskets and O-rings.
- Tighten oil pan (upper) bolts in numerical order as shown.
- There are two types of bolts.

- M8 × 100 mm (3.97 in) : 7, 11, 12, 13**
M8 × 25 mm (0.98 in) : All except the above

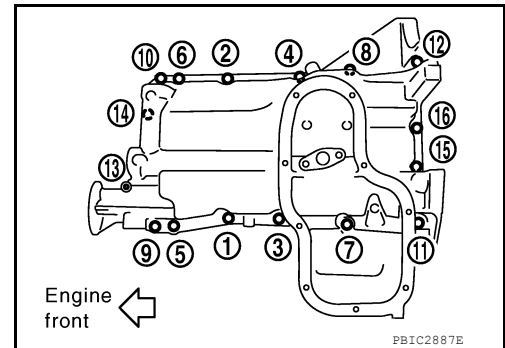

- e. Tighten transmission joint bolts. Refer to [TM-21, "Removal and Installation from Vehicle"](#) (4WD M/T models), [TM-250, "Removal and Installation \(2WD\)"](#) (2WD A/T models), [TM-252, "Removal and Installation \(4WD\)"](#) (4WD A/T models).

2. Install oil strainer to oil pan (upper).
3. Installation of the remaining components is in the reverse order of removal.

CAUTION:

Do not fill the engine with oil for at least 30 minutes after oil pan is installed.

INSPECTION AFTER INSTALLATION

- Before starting engine, check oil/fluid levels including engine coolant and engine oil. If less than required quantity, fill to the specified level. Refer to [MA-12, "Fluids and Lubricants"](#).
- Use procedure below to check for fuel leakage.
- Turn ignition switch ON (with engine stopped). With fuel pressure applied to fuel piping, check for fuel leakage at connection points.
- Start engine. With engine speed increased, check again for fuel leakage at connection points.
- Run engine to check for unusual noise and vibration.

NOTE:

OIL PAN AND OIL STRAINER

< REMOVAL AND INSTALLATION >

[VQ40DE]

If hydraulic pressure inside timing chain tensioner drops after removal and installation, slack in the guide may generate a pounding noise during and just after engine start. However, this is normal. Noise will stop after hydraulic pressure rises.

- Warm up engine thoroughly to make sure there is no leakage of fuel, exhaust gas, or any oils/fluids including engine oil and engine coolant.
- Bleed air from passages in lines and hoses, such as in cooling system.
- After cooling down engine, again check oil/fluid levels including engine oil and engine coolant. Refill to specified level, if necessary.
- Summary of the inspection items:

Item		Before starting engine	Engine running	After engine stopped
Engine coolant		Level	Leakage	Level
Engine oil		Level	Leakage	Level
Transmission/ transaxle fluid	A/T and CVT Models	Leakage	Level/Leakage	Leakage
	M/T Models	Level/Leakage	Leakage	Level/Leakage
Other oils and fluids*		Level	Leakage	Level
Fuel		Leakage	Leakage	Leakage
Exhaust gas		—	Leakage	—

*Power steering fluid, brake fluid, etc.

A
EM
C
D
E
F
G
H
I
J
K
L
M
N
O
P

IGNITION COIL

< REMOVAL AND INSTALLATION >

[VQ40DE]

IGNITION COIL

Exploded View

INFOID:000000011069701

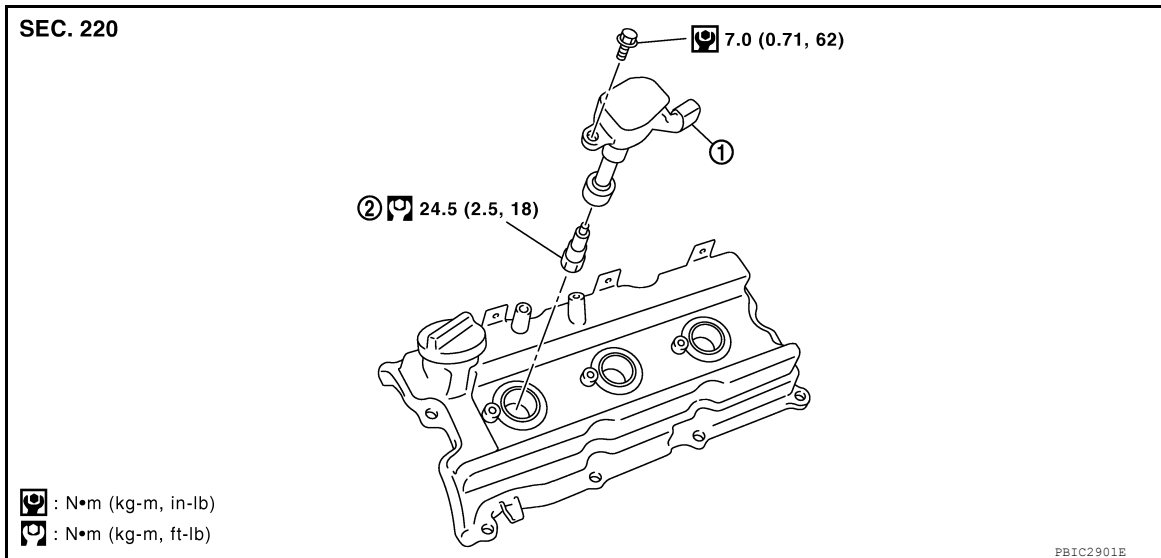

1. Ignition coil

2. Spark plug

Removal and Installation

INFOID:000000011069702

REMOVAL (LH)

1. Move aside harness, harness bracket, and hoses located above ignition coil.
2. Disconnect harness connector from ignition coil.
3. Remove ignition coil.

CAUTION:

Do not shock ignition coil.

INSTALLATION (LH)

Installation is in the reverse order of removal.

REMOVAL (RH)

1. Remove intake manifold collector. Refer to [EM-25, "Removal and Installation"](#).
2. Move aside harness, harness bracket, and hoses located above ignition coil.
3. Disconnect harness connector from ignition coil.
4. Remove ignition coil.

CAUTION:

Do not shock ignition coil.

INSTALLATION (RH)

Installation is in the reverse order of removal.

ROCKER COVER

< REMOVAL AND INSTALLATION >

[VQ40DE]

ROCKER COVER

Exploded View

INFOID:000000011069703

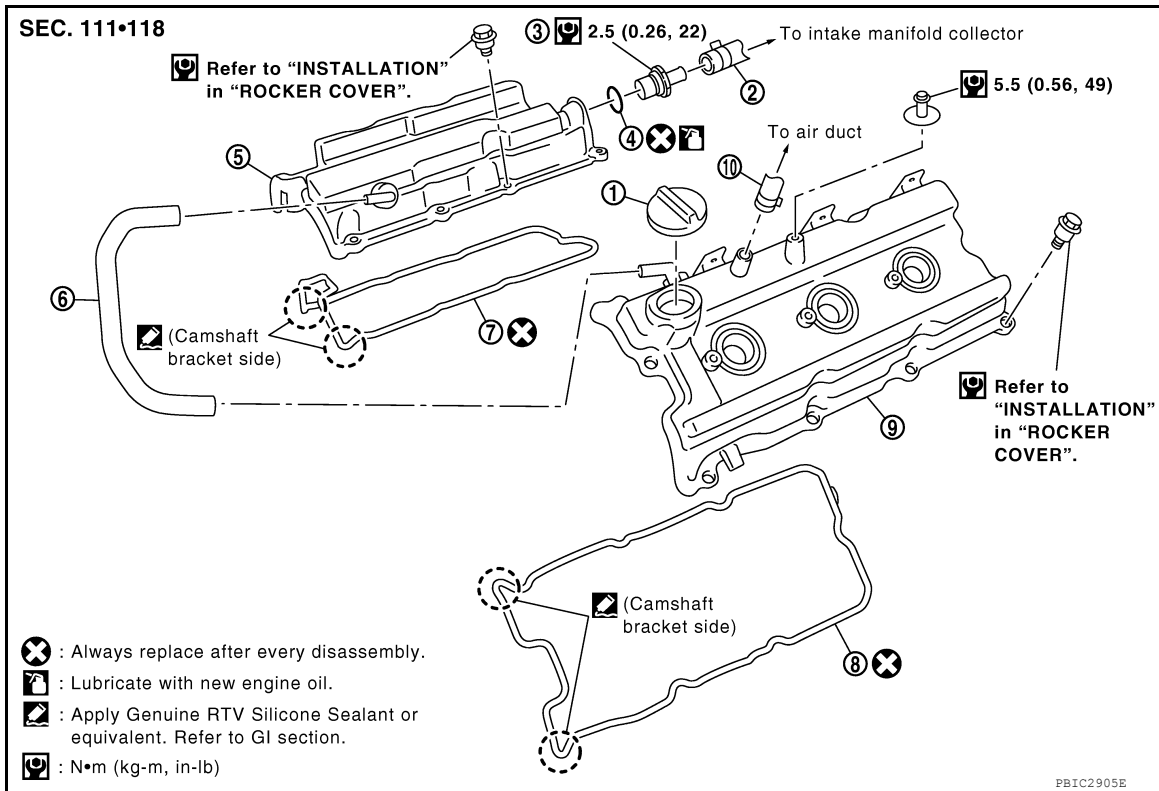

- | | | |
|-----------------------------|-----------------------------|----------------------|
| 1. Oil filler cap | 2. PCV hose | 3. PCV valve |
| 4. O-ring | 5. Rocker cover (RH) | 6. PCV hose |
| 7. Rocker cover gasket (RH) | 8. Rocker cover gasket (LH) | 9. Rocker cover (LH) |
| 10. PCV hose | | |

Removal and Installation

INFOID:000000011069704

REMOVAL (LH)

- Remove ignition coils. Refer to [EM-40. "Removal and Installation"](#).
- Separate engine harness removing their brackets from rocker covers.
- Remove harness bracket from cylinder head, if necessary.
- Disconnect the intake valve timing control solenoid valve (LH bank). Refer to [EM-51. "Exploded View"](#).
- Remove PCV hoses from rocker covers.
- Remove oil filler cap from rocker cover (LH), if necessary.
- Remove the rocker cover bolts using power tool in reverse order as shown.
 - ←: Front

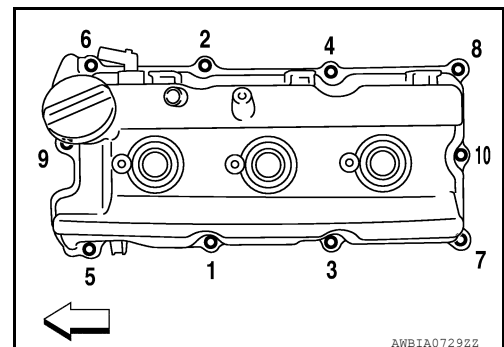

ROCKER COVER

[VQ40DE]

< REMOVAL AND INSTALLATION >

8. Remove rocker cover.
9. Remove rocker cover gaskets from rocker covers.
10. Use scraper to remove all traces of liquid gasket from cylinder head and camshaft bracket (No. 1).

CAUTION:

Do not scratch or damage the mating surface when cleaning off old liquid gasket.

INSTALLATION (LH)

1. Apply liquid gasket using suitable tool to joint of rocker cover, cylinder head and camshaft bracket (No. 1) as follows:
Use Genuine RTV Silicone Sealant or equivalent. Refer to [GI-21, "Recommended Chemical Products and Sealants"](#).

NOTE:

The figure shows an example of LH side [zoomed in shows camshaft bracket (No. 1)].

- a. Apply liquid gasket to joint part of camshaft bracket (a) (No. 1) and cylinder head.
- b. Apply liquid gasket (b) 90° to figure (a).

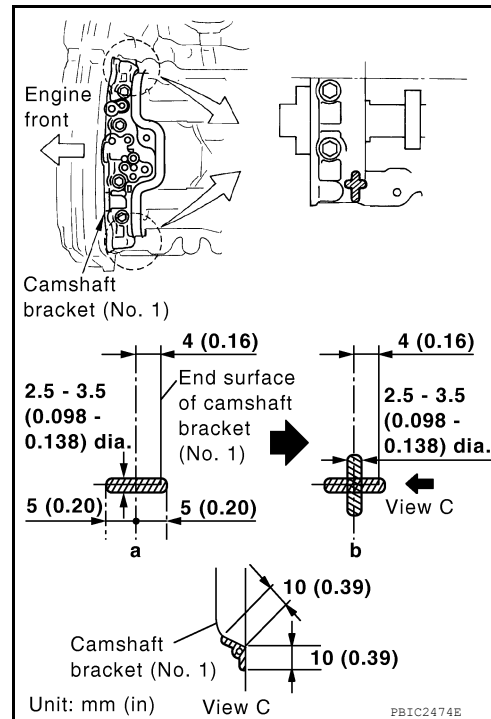

2. Install new rocker cover gasket to rocker cover.
3. Install rocker cover.
 - Check to be sure rocker cover gasket is not dropped from installation groove of rocker cover.
4. Tighten the rocker cover bolts in two steps in numerical order as shown.
 - ⇐: Front

1st step : 1.96 N·m (0.20 kg-m, 17 in-lb)

2nd step : 8.33 N·m (0.85 kg-m, 74 in-lb)

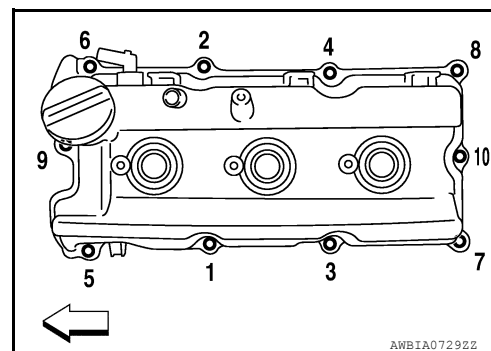

5. Install oil filler cap to rocker cover (LH), if removed.
6. Install PCV hose.
 - Insert PCV hose by 25 to 30 mm (0.98 to 1.18 in) from connector end.
 - When installing, be careful not to twist or come in contact with other parts.
7. Installation of the remaining components is in the reverse order of removal.
 - Check engine oil level and adjust as necessary. Refer to [LU-7, "Inspection"](#).

REMOVAL (RH)

1. Remove intake manifold collector. Refer to [EM-25, "Removal and Installation"](#).

CAUTION:

Perform this step when engine is cold.

2. Separate engine harness removing their brackets from rocker covers.

ROCKER COVER

[VQ40DE]

< REMOVAL AND INSTALLATION >

3. Remove harness bracket from cylinder head (RH). Refer to [EM-88, "Removal and Installation"](#).
4. Disconnect the intake valve timing control solenoid valve (RH bank). Refer to [EM-51, "Exploded View"](#).
5. Remove ignition coils. Refer to [EM-40, "Removal and Installation"](#).
6. Remove PCV hoses from rocker cover.
7. Remove PCV valve and O-ring from rocker cover (RH), if necessary.

CAUTION:

Do not reuse O-ring.

8. Remove the rocker cover bolts using power tool in reverse order as shown.
 - : Front

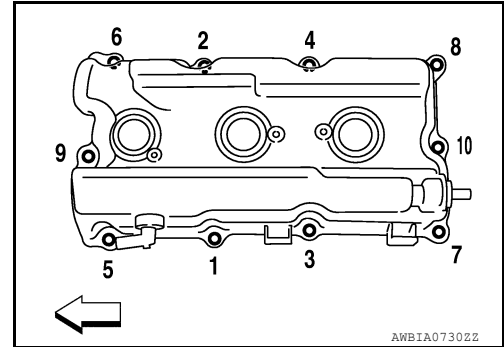

9. Remove rocker cover.
10. Remove rocker cover gaskets from rocker covers.
11. Use scraper to remove all traces of liquid gasket from cylinder head and camshaft bracket (No. 1).

CAUTION:

Do not scratch or damage the mating surface when cleaning off old liquid gasket.

INSTALLATION (RH)

1. Apply liquid gasket using suitable tool to joint part among rocker cover, cylinder head and camshaft bracket (No. 1) as follows: **Use Genuine RTV Silicone Sealant or equivalent. Refer to [GI-21, "Recommended Chemical Products and Sealants"](#).**

NOTE:

The figure shows an example of LH side [zoomed in shows camshaft bracket (No. 1)].

- a. Apply liquid gasket to joint part of camshaft bracket (a) (No. 1) and cylinder head.
- b. Apply liquid gasket (b) 90° to figure (a).

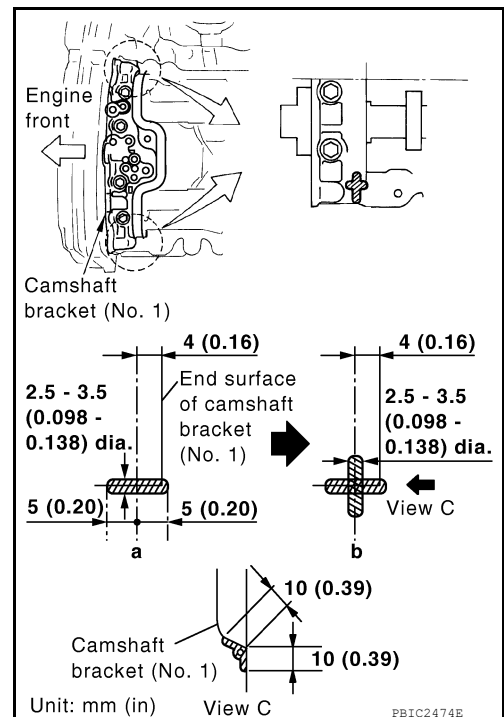

2. Install new rocker cover gasket to rocker cover.
3. Install rocker cover.
 - Check to be sure rocker cover gasket is not dropped from installation groove of rocker cover.

ROCKER COVER

[VQ40DE]

< REMOVAL AND INSTALLATION >

4. Tighten the rocker cover bolts in two steps in numerical order as shown.
- ⇐: Front

1st step : 1.96 N·m (0.20 kg-m, 17 in-lb)

2nd step : 8.33 N·m (0.85 kg-m, 74 in-lb)

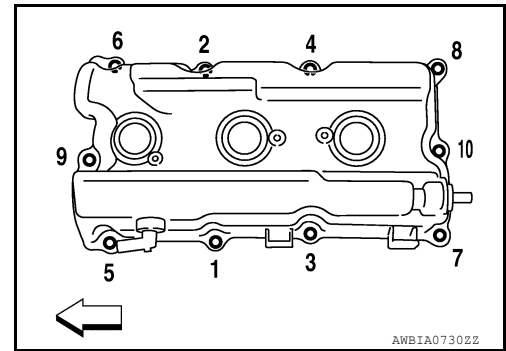

5. Install new O-ring and PCV valve to rocker cover (RH), if removed.
- CAUTION:**
Do not reuse O-ring.
6. Install PCV hose.
- Insert PCV hose by 25 to 30 mm (0.98 to 1.18 in) from connector end.
 - When installing, be careful not to twist or come in contact with other parts.
7. Installation of the remaining components is in the reverse order of removal.
- Check engine oil level and adjust as necessary. Refer to [LU-7, "Inspection"](#).

FUEL INJECTOR AND FUEL TUBE

< REMOVAL AND INSTALLATION >

[VQ40DE]

FUEL INJECTOR AND FUEL TUBE

Exploded View

INFOID:000000011069705

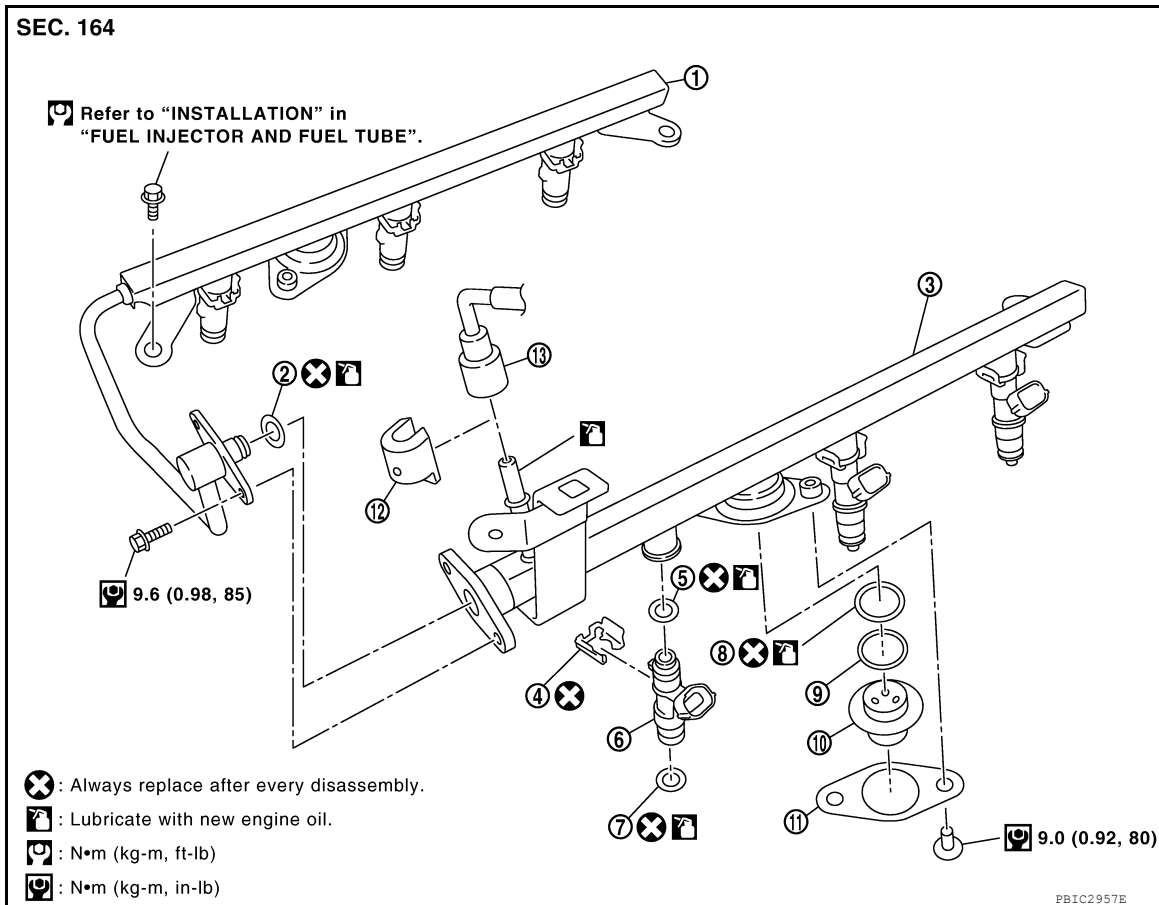

- | | | |
|--------------------|---------------------|-------------------------|
| 1. Fuel tube (RH) | 2. O-ring | 3. Fuel tube (LH) |
| 4. Clip | 5. O-ring (blue) | 6. Fuel injector |
| 7. O-ring (brown) | 8. O-ring | 9. Spacer |
| 10. Fuel damper | 11. Fuel damper cap | 12. Quick connector cap |
| 13. Fuel feed hose | | |

Removal and Installation

INFOID:000000011069706

WARNING:

- Put a "CAUTION FLAMMABLE" sign in the workshop.
- Be sure to work in a well ventilated area and furnish workshop with a CO₂ fire extinguisher.
- Do not smoke while servicing fuel system. Keep open flames and sparks away from the work area.
- To avoid the danger of being scalded, do not drain engine coolant when engine is hot.

CAUTION:

Do not remove or disassemble parts unless instructed.

NOTE:

When removing components such as hoses, tubes/lines, etc., cap or plug openings to prevent fluid from spilling.

REMOVAL

1. Release the fuel pressure. Refer to [EC-502, "Fuel Pressure Check"](#).
2. Disconnect the battery negative terminal. Refer to [PG-77, "Removal and Installation"](#).
3. Remove intake manifold collector. Refer to [EM-25, "Removal and Installation"](#).

CAUTION:

FUEL INJECTOR AND FUEL TUBE

< REMOVAL AND INSTALLATION >

[VQ40DE]

Perform this step when engine is cold.

4. Disconnect the fuel quick connector on the engine side.
 - a. Remove quick connector cap.

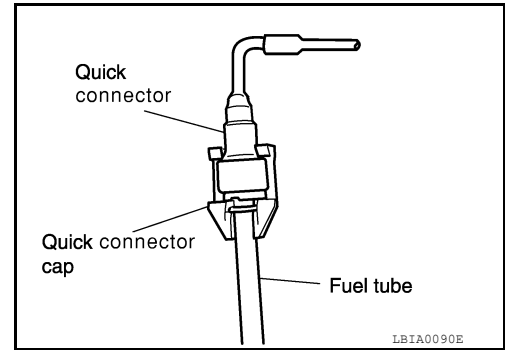

- b. With the sleeve side of Tool facing quick connector, install Tool onto fuel tube.

Tool number : — (J-45488)

- c. Insert Tool into quick connector until sleeve contacts and goes no further. Hold the Tool on that position.

CAUTION:

Inserting the Tool hard will not disconnect quick connector. Hold Tool where it contacts and goes no further.

- d. Pull the quick connector straight out from the fuel tube.

CAUTION:

- Pull quick connector holding it at the (A) position, as shown.
- Do not pull with lateral force applied. O-ring inside quick connector may be damaged.
- Do not reuse O-rings.
- Prepare container and cloth beforehand as fuel will leak out.
- Avoid fire and sparks.
- Be sure to cover openings of disconnected pipes with plug or plastic bag to avoid fuel leakage and entry of foreign materials.

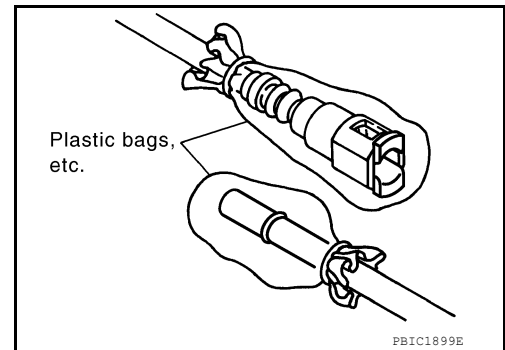
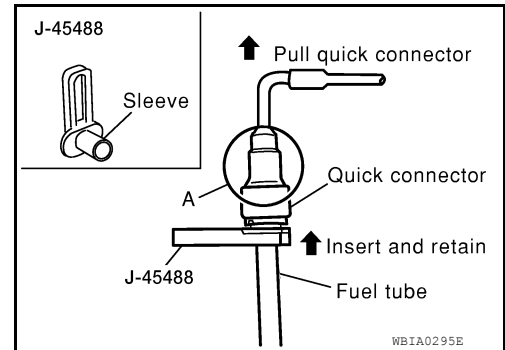

5. Remove PCV hose between rocker covers (right and left banks).
6. Disconnect harness connector from fuel injector.
7. Loosen bolts in reverse order as shown, and remove fuel tube and fuel injector assembly.

CAUTION:

Do not tilt it, or remaining fuel in pipes may flow out from pipes.

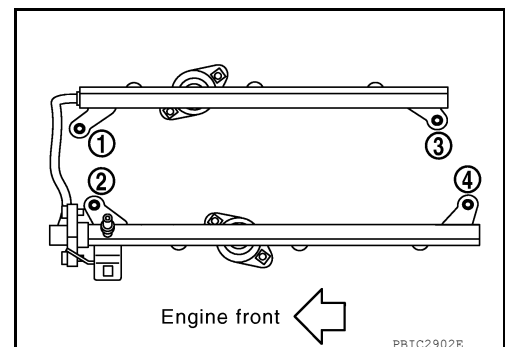

8. Remove bolts which connects fuel tube (RH) and fuel tube (LH).

FUEL INJECTOR AND FUEL TUBE

[VQ40DE]

< REMOVAL AND INSTALLATION >

9. Remove fuel injector from fuel tube as follows:
 - a. Carefully open and remove clip.
 - b. Remove fuel injector from fuel tube by pulling straight.

CAUTION:

- Be careful with remaining fuel that may leak out from fuel tube.
- Do not damage injector nozzles during removal.
- Do not bump or drop fuel injectors.
- Do not disassemble fuel injectors.

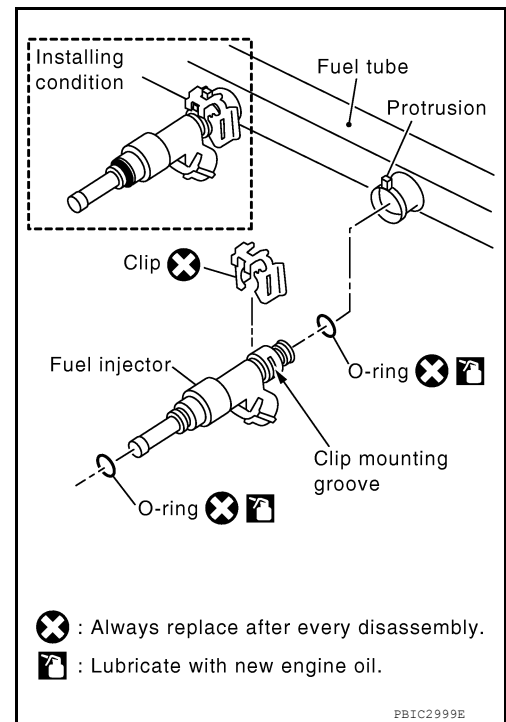

10. Disconnect fuel tube (RH) from fuel tube (LH).
11. Loosen bolts, to remove fuel damper cap and fuel damper, if necessary.

INSTALLATION

1. Install fuel damper as follows:
 - a. Install new O-ring to fuel tube as shown.
 - When handling new O-rings, be careful of the following caution:

CAUTION:

- Handle O-ring with bare hands. Do not wear gloves.
- Do not reuse O-ring.
- Lubricate new O-ring with new engine oil.
- Do not clean O-ring with solvent.
- Make sure that O-ring and its mating part are free of foreign material.
- When installing O-ring, do not scratch it with tool or fingernails.
- Do not twist or stretch O-ring. If O-ring was stretched while it was being attached, allow it to retract before inserting it into fuel tube.
- Insert new O-ring straight into fuel tube. Do not angle or twist it.

- b. Install spacer to fuel damper.
- c. Insert fuel damper straight into fuel tube.

CAUTION:

- Insert straight, making sure that the axis is lined up.
- Do not pressure-fit with excessive force.

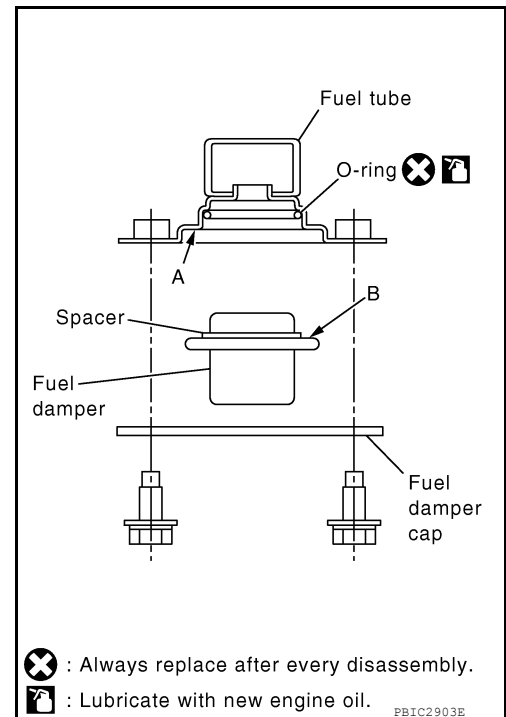

Reference value : 130 N (13.3 kg, 29.2 lb)

- d. Tighten bolts evenly in turn.
 - After tightening bolts, make sure that there is no gap between fuel damper cap and fuel tube.
2. Install new O-rings to fuel injector, paying attention to the following.

CAUTION:

- Do not reuse O-rings.

FUEL INJECTOR AND FUEL TUBE

< REMOVAL AND INSTALLATION >

[VQ40DE]

- Upper and lower O-ring are different colors.

Fuel tube side : Blue

Nozzle side : Brown

- Handle O-ring with bare hands. Do not wear gloves.
- Lubricate new O-ring with new engine oil.
- Do not clean O-ring with solvent.
- Make sure that O-ring and its mating part are free of foreign material.
- When installing O-ring, be careful not to scratch it with tool or fingernails.
- Do not twist or stretch O-ring. If O-ring was stretched while it was being attached, allow it to retract before inserting it into fuel tube.
- Insert O-ring straight into fuel injector. Do not angle or twist it.

3. Install fuel injector to fuel tube as follows:

- a. Insert clip (3) into clip groove (F) on fuel injector (5).
- Insert clip so that protrusion (E) of fuel injector matches cutout (C) of clip.

CAUTION:

- Do not reuse O-rings (2 and 4).
- Do not reuse clip. Replace it with new one.
- Be careful to keep clip from interfering with O-ring (2). If interference occurs, replace O-ring (2).

- b. Insert fuel injector into fuel tube (1) with clip attached.
- Insert it while matching it to the axial center.
 - Insert fuel injector so that protrusion (A) of fuel tube matches cutout (B) of clip.
 - Check that fuel tube flange (G) is securely fixed in flange fixing groove (D) on clip.
- c. Check that installation is complete by checking that fuel injector does not rotate or come off.
- Check that protrusions of fuel injectors and fuel tubes are aligned with cutouts of clips after installation.

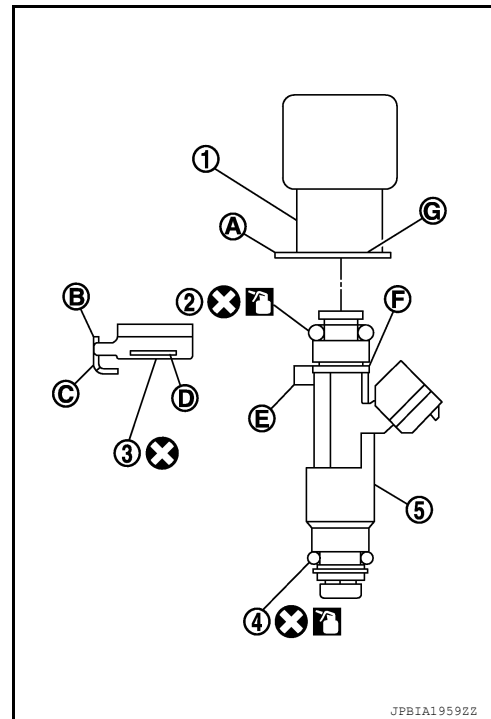

4. Connect the fuel tube (RH) to the fuel tube (LH), and tighten bolts temporarily.
- Tighten bolts to the specified torque after installing fuel tube and fuel injector assembly.

CAUTION:

- Handle O-ring with bare hands. Do not wear gloves.
- Do not reuse O-rings.
- Lubricate O-ring with new engine oil.
- Do not clean O-ring with solvent.
- Make sure that O-ring and its mating part are free of foreign material.
- When installing O-ring, be careful not to scratch it with tool or fingernails.
- Do not twist or stretch O-ring. If O-ring was stretched while it was being attached, allow it to retract before inserting it into fuel tube.
- Insert new O-ring straight into fuel tube. Do not angle or twist it.

5. Install fuel tube and fuel injector assembly to intake manifold.

CAUTION:

- Do not let the tip of the injector nozzle come in contact with other parts.

FUEL INJECTOR AND FUEL TUBE

< REMOVAL AND INSTALLATION >

[VQ40DE]

- Tighten bolts in two steps in numerical order as shown.

Fuel injector tube assembly bolts

1st step : 10.1 N·m (1.0 kg-m, 7 ft-lb)

2nd step : 22.0 N·m (2.2 kg-m, 16 ft-lb)

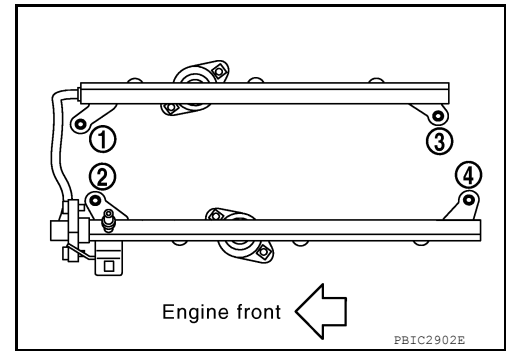

6. Tighten bolts which connect fuel tube (RH) and fuel tube (LH) to the specified torque.
7. Connect fuel injector harness connector.
8. Install intake manifold collector. Refer to [EM-25. "Removal and Installation"](#).
9. Installation of the remaining components is in the reverse order of removal.

INSPECTION AFTER INSTALLATION

Check on Fuel Leakage

1. Apply fuel pressure to the fuel lines by turning ignition switch ON (with engine stopped). Then check for fuel leaks at the connections.
2. Start the engine and rev it up and check for fuel leaks at the connections.

WARNING:

Do not touch engine immediately after stopping, as engine becomes extremely hot.

NOTE:

Use mirrors for checking at points out of clear sight.

INTAKE VALVE TIMING CONTROL

< REMOVAL AND INSTALLATION >

[VQ40DE]

INTAKE VALVE TIMING CONTROL

Intake Valve Timing Control Solenoid Valve (LH)

INFOID:000000011069707

REMOVAL

1. Disconnect the harness connector from intake valve timing control solenoid valve (LH).
2. Remove intake valve timing control solenoid valve bolts (LH) and O-ring from rocker cover.

CAUTION:

Do not reuse O-ring.

INSTALLATION

Installation is in the reverse order of removal. Refer to [EM-51, "Exploded View"](#).

CAUTION:

- Do not reuse O-rings.
- Lubricate the new O-ring for the intake valve timing control solenoid valve with clean engine oil before installing.

Intake Valve Timing Control Solenoid Valve (RH)

INFOID:000000011069708

REMOVAL

1. Remove intake manifold collector. Refer to [EM-25, "Removal and Installation"](#).
2. Disconnect the harness connector from intake valve timing control solenoid valve (RH).
3. Remove intake valve timing control solenoid valve bolts (RH) and O-ring from rocker cover.

CAUTION:

Do not reuse O-ring.

INSTALLATION

Installation is in the reverse order of removal. Refer to [EM-51, "Exploded View"](#).

CAUTION:

- Do not reuse O-rings.
- Lubricate the new O-ring for the intake valve timing control solenoid valve with clean engine oil before installing.

FRONT TIMING CHAIN CASE

< REMOVAL AND INSTALLATION >

[VQ40DE]

FRONT TIMING CHAIN CASE

Exploded View

INFOID:0000000011069709

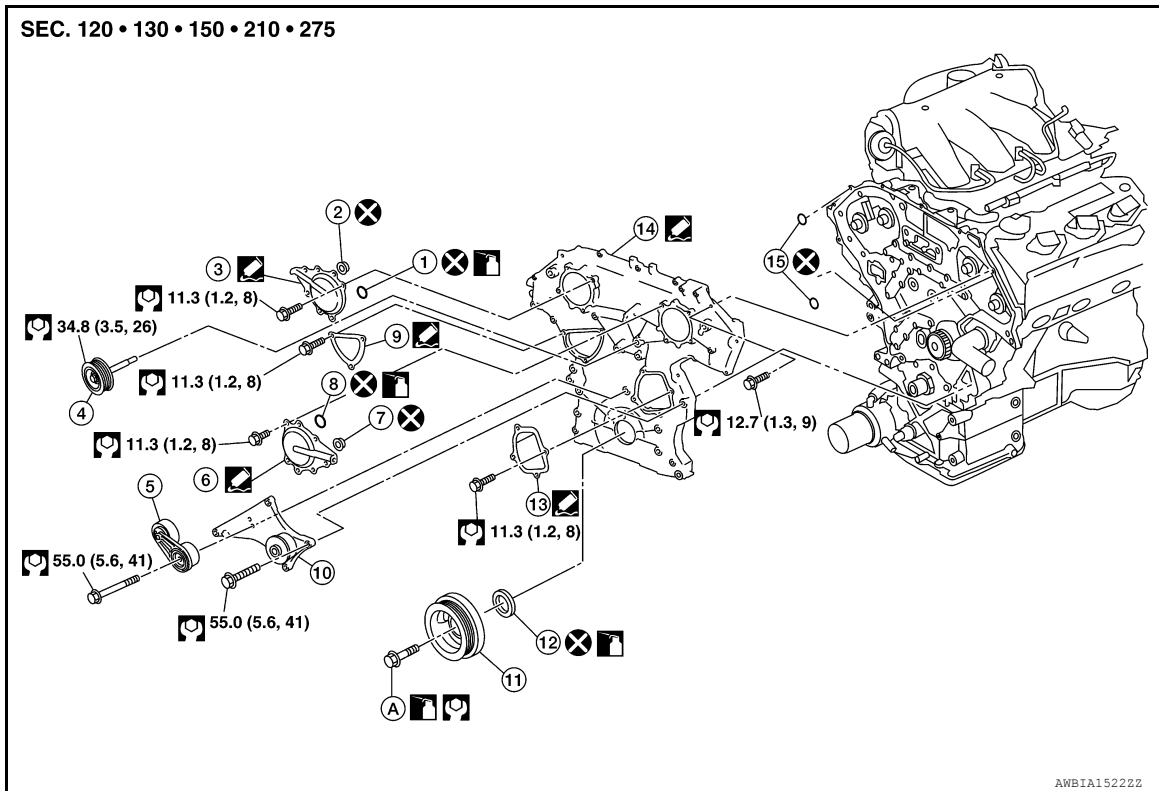

- | | | |
|-------------------------|------------------------------|-------------------------------------------|
| 1. O-ring | 2. Collared O-ring | 3. Intake valve timing control cover (RH) |
| 4. Idler pulley | 5. Drive belt auto-tensioner | 6. Intake valve timing control cover (LH) |
| 7. Collared O-ring | 8. O-ring | 9. Chain tensioner cover |
| 10. Cooling fan bracket | 11. Crankshaft pulley | 12. Front oil seal |
| 13. Water pump cover | 14. Front timing chain case | 15. O-ring |
- A. Refer to [EM-51](#)

Removal and Installation

INFOID:0000000011069710

NOTE:

When removing components such as hoses, tubes/lines, etc., cap or plug openings to prevent fluid from spilling.

REMOVAL

1. Drain engine oil. Refer to [LU-8, "Changing Engine Oil"](#).
CAUTION:
 - Perform this step when engine is cold.
 - Do not spill engine oil on drive belts.
2. Drain engine coolant from radiator. Refer to [CO-11, "Changing Engine Coolant"](#).
CAUTION:
 - Perform this step when engine is cold.
 - Do not spill engine coolant on drive belts.
3. Remove engine cooling fan (Motor driven type). Refer to [CO-19, "Removal and Installation \(Motor driven type\)"](#).
4. Disconnect engine harnesses and remove harness brackets from front timing chain case.
5. Remove EVAP canister purge volume control solenoid valve, if necessary.
6. Remove drive belt. Refer to [EM-13, "Removal and Installation"](#).

FRONT TIMING CHAIN CASE

[VQ40DE]

< REMOVAL AND INSTALLATION >

7. Remove power steering oil pump from bracket with piping connected, and temporarily secure it aside. Refer to [ST-17, "Removal and Installation"](#).
8. Remove power steering oil pump bracket. Refer to [ST-17, "Removal and Installation"](#).
9. Remove generator. Refer to [CHG-27, "Removal and Installation"](#).
10. Remove water bypass hoses and water hose clamp.
11. Remove engine cooling fan (Crankshaft driven type) and fan bracket. Refer to [CO-18, "Removal and Installation \(Crankshaft driven type\)"](#).
12. Remove water hose at oil cooler.
13. Remove oil cooler water bypass pipe from front timing chain case. Refer to [EM-51, "Exploded View"](#).
14. Remove right and left intake valve timing control covers.
 - Loosen bolts in reverse order as shown.
 - Cut liquid gasket for removal using Tool.

Tool number : KV10111100 (J-37228)

CAUTION:

- Shaft is internally jointed with camshaft sprocket (INT) center hole. When removing, keep it horizontal until it is completely disconnected.
- Do not damage the mating surfaces.

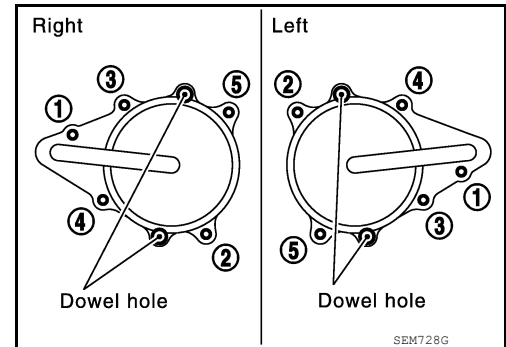

15. Remove collared O-rings from front timing chain case (left and right side).

CAUTION:

Do not reuse O-rings.

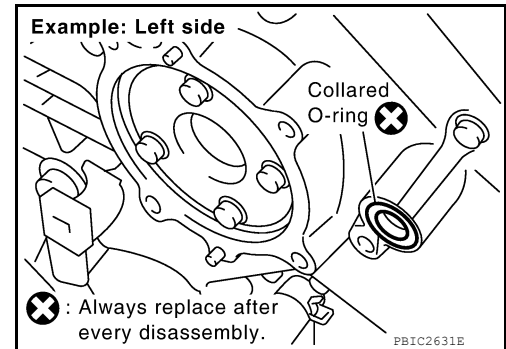

16. Remove A/C compressor bolts and temporarily secure A/C compressor aside. Refer to [HA-27, "Removal and Installation of Compressor"](#).
17. Remove crankshaft pulley as follows:
 - a. Remove access plate and install Ring Gear Stopper Tool.

Tool number : KV11105210 (J-44716)

17. Remove crankshaft pulley as follows:
 - b. Loosen crankshaft pulley bolt so that there is a 10 mm (0.39 in) gap between bolt and crankshaft pulley.

CAUTION:

Do not remove crankshaft pulley bolt. Keep loosened crankshaft pulley bolt in place to protect the crankshaft pulley from dropping.

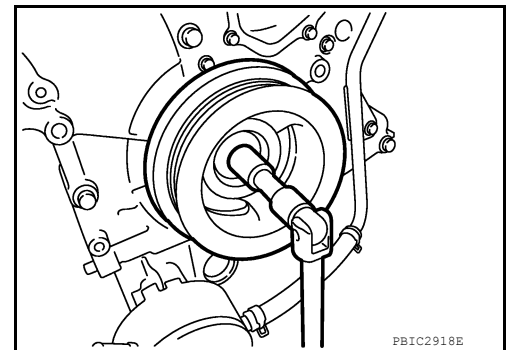

17. Remove crankshaft pulley as follows:
 - c. Pull crankshaft pulley with both hands to remove it.

FRONT TIMING CHAIN CASE

[VQ40DE]

< REMOVAL AND INSTALLATION >

18. Loosen two bolts in front of oil pan (upper) in reverse order as shown.

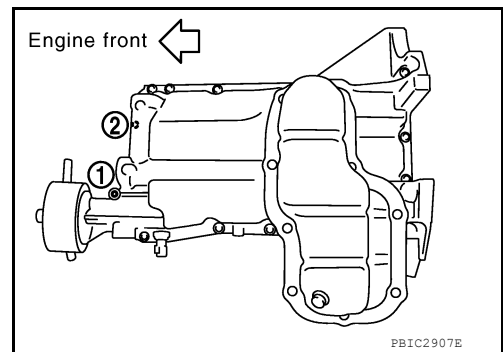

19. Remove front timing chain case as follows:
 a. Loosen bolts with power tool in reverse order as shown.

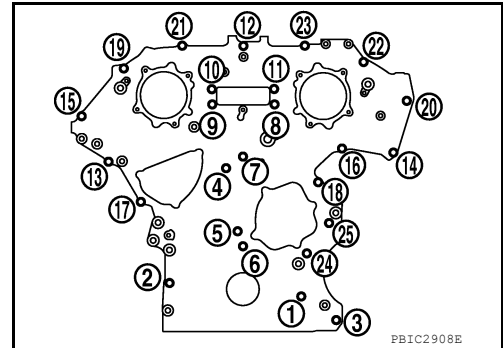

- b. Insert suitable tool into the notch at the top of the front timing chain case as shown (1).
 c. Pry off case by moving tool as shown (2).
 • Cut liquid gasket for removal using Tool.

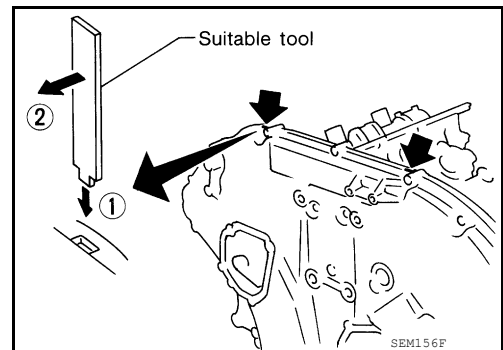

Tool number : KV10111100 (J-37228)

CAUTION:

- Do not use screwdriver or something similar.
- After removal, handle front timing chain case carefully so it does not twist, bend, or warp under a load.
- Do not damage the mating surface.

20. Remove O-rings from rear timing chain case.

CAUTION:

Do not reuse O-rings.

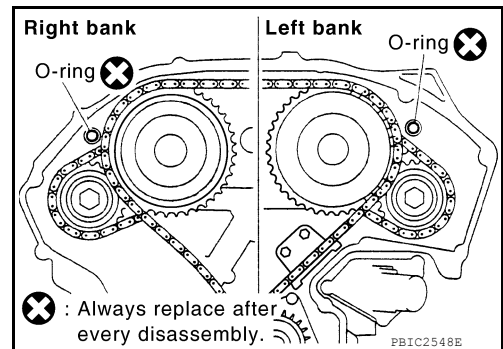

21. If necessary, remove water pump cover and chain tensioner cover from front timing chain case.
 • Cut liquid gasket for removal using Tool.

Tool number : KV10111100 (J-37228)

CAUTION:

Do not damage the mating surfaces.

A
EM
C
D
E
F
G
H
I
J
K
L
M
N
O
P

FRONT TIMING CHAIN CASE

[VQ40DE]

< REMOVAL AND INSTALLATION >

22. Remove front oil seal from front timing chain case using suitable tool.

CAUTION:

Be careful not to damage front timing chain case.

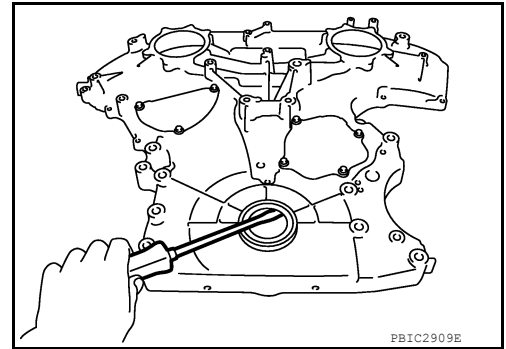

23. Remove idler pulley, if necessary. Refer to [EM-14. "Drive Belt Auto-Tensioner and Idler Pulley"](#).

24. Use a scraper to remove all traces of old liquid gasket from front and rear timing chain cases, oil pan (upper), and liquid gasket mating surfaces.

CAUTION:

Be careful not to allow gasket fragments to enter oil pan.

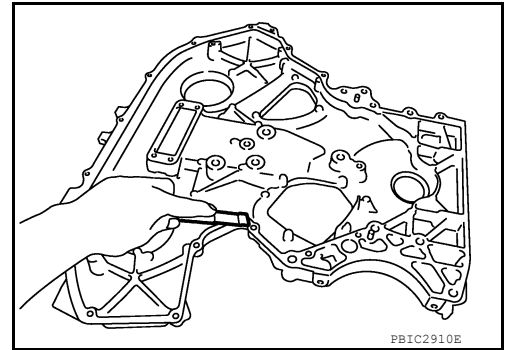

- Remove old liquid gasket from bolt hole and thread.

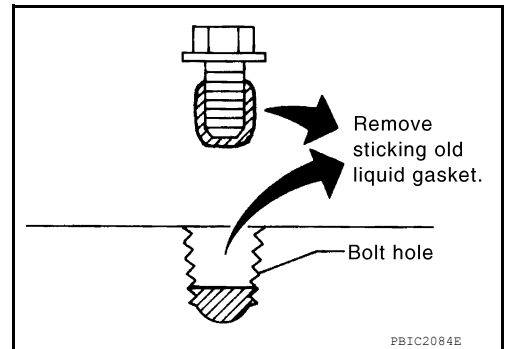

25. Use a scraper to remove all traces of old liquid gasket from water pump cover, chain tensioner cover (if necessary) and intake valve timing control covers.

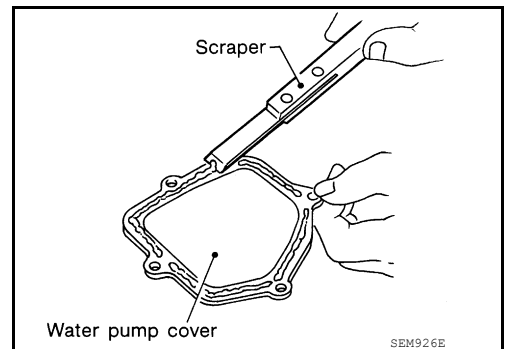

INSTALLATION

FRONT TIMING CHAIN CASE

< REMOVAL AND INSTALLATION >

[VQ40DE]

1. Hammer dowel pins (right and left) into front timing chain case up to a point close to taper in order to shorten protrusion length.
NOTE:
Be sure to place dowel pins in the original holes in front timing chain case.

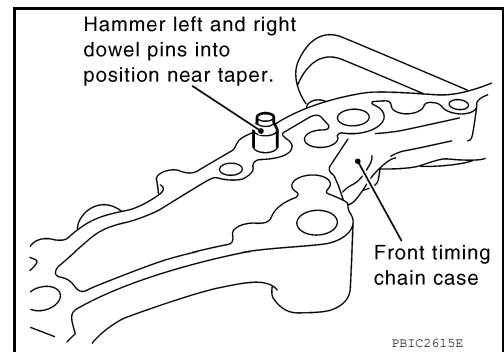

2. Install new front oil seal on the front timing chain case.
 - Apply new engine oil to both oil seal lip and dust seal lip.
 - Install it so that each seal lip is oriented as shown.

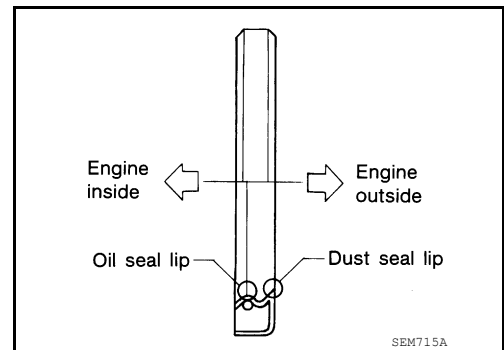

- Press-fit oil seal until it becomes flush with front timing chain case end face using suitable drift [outer diameter: 60 mm (2.36 in)].
- Make sure the garter spring is in position and seal lip is not inverted.

CAUTION:

- **Be careful not to damage front timing chain case and crankshaft.**
- **Press-fit straight and avoid causing burrs or tilting oil seal.**

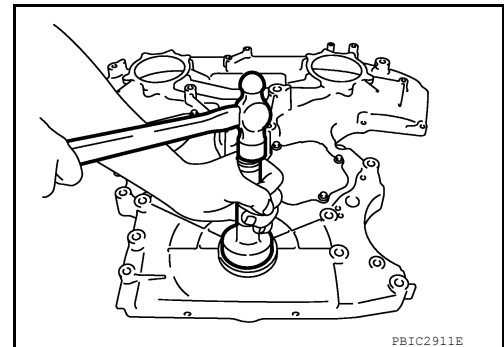

3. Install water pump cover and chain tensioner cover to front timing chain case, if removed.
 - Apply a continuous bead of liquid gasket using suitable tool to front timing chain case as shown.

Use Genuine RTV Silicone Sealant or equivalent. Refer to [GI-21, "Recommended Chemical Products and Sealants"](#).

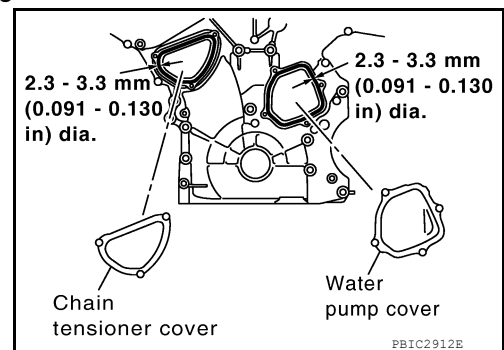

4. Install idler pulley, if removed.
5. Install front timing chain case as follows:

FRONT TIMING CHAIN CASE

[VQ40DE]

< REMOVAL AND INSTALLATION >

- a. Apply a continuous bead of liquid gasket using suitable tool to front timing chain case back side as shown.
Use Genuine RTV Silicone Sealant or equivalent. Refer to GI-21, "Recommended Chemical Products and Sealants".

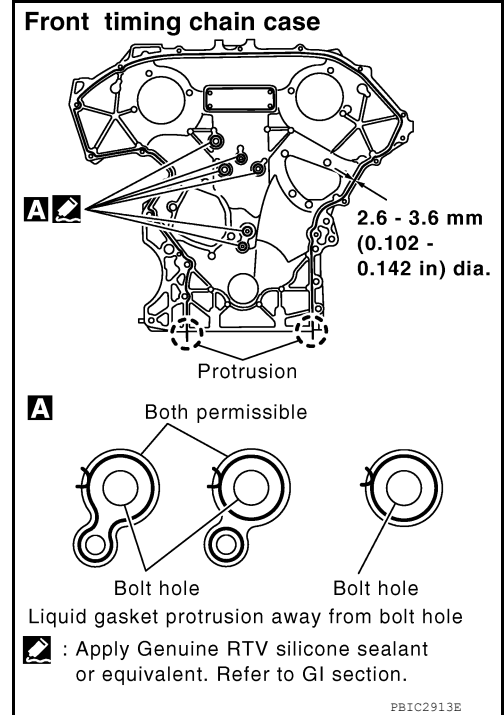

- b. Install new O-rings on rear timing chain case.
CAUTION:
Do not reuse O-rings.
- c. Assemble front timing chain case as follows:

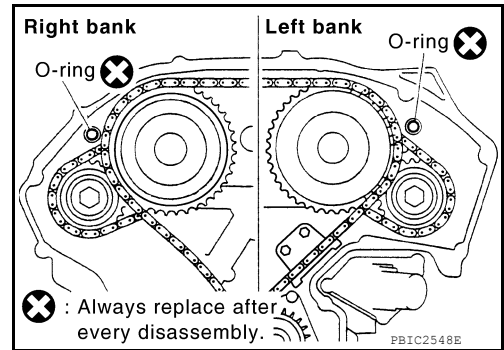

- i. Fit lower end of front timing chain case tightly onto top face of oil pan (upper). From the fitting point, make entire front timing chain case contact rear timing chain case completely.

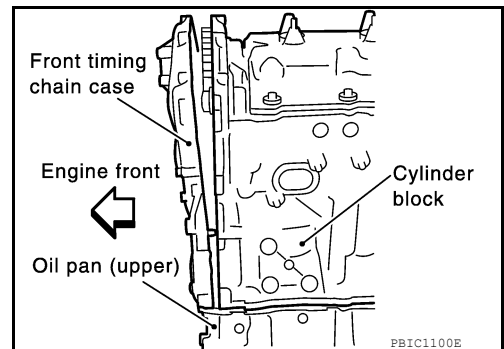

- ii. Since front timing chain case is offset for difference of bolt holes, tighten bolts temporarily while holding front timing chain case from front and top as shown.
- iii. Same as the previous step, insert dowel pin while holding front timing chain case from front and top completely.

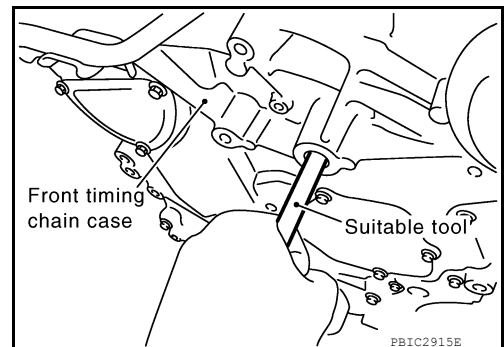

FRONT TIMING CHAIN CASE

[VQ40DE]

< REMOVAL AND INSTALLATION >

- d. Tighten bolts to the specified torque in numerical order as shown.
- e. After all bolts are tightened, retighten them to the specified torque in numerical order as shown.
 - There are two types of bolts.

Bolt position	Bolt diameter
1 - 5	: 10 mm (0.39 in)
6 - 25	: 6 mm (0.24 in)

Bolt position	Tightening specification
1 - 5	: 55.0 N·m (5.6 kg-m, 41 ft-lb)
6 - 25	: 12.7 N·m (1.3 kg-m, 9 ft-lb)

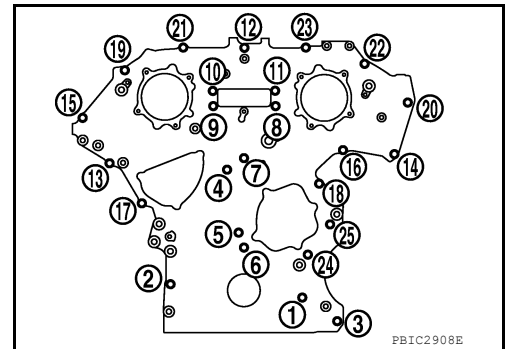

6. Install two bolts in front of oil pan (upper) in numerical order as shown.

Front oil pan bolt : 22.0 N·m (2.2 kg-m, 16 ft-lb)

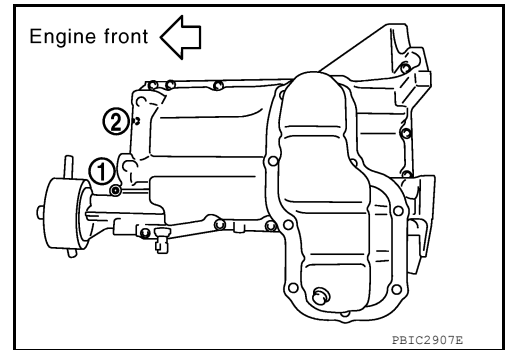

7. Install right and left intake valve timing control covers as follows:
 - a. Install new seal rings in shaft grooves.
 - b. Apply a continuous bead of liquid gasket using suitable tool to intake valve timing control covers as shown.

Use Genuine RTV Silicone Sealant or equivalent. Refer to [GI-21, "Recommended Chemical Products and Sealants"](#).

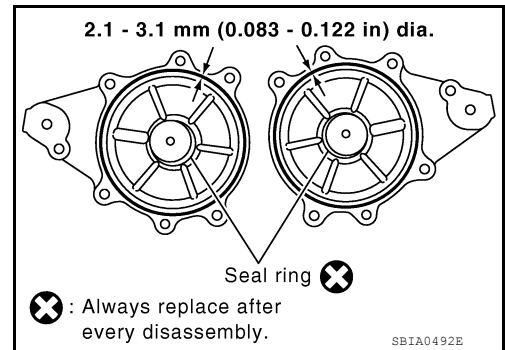

- c. Install new collared O-rings in front timing chain case oil hole (left and right sides).

CAUTION:
Do not reuse O-rings.

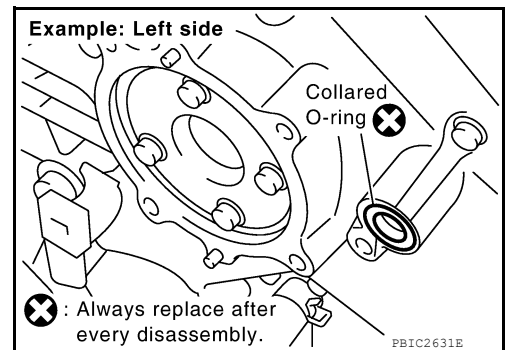

- d. Being careful not to move seal ring from the installation groove, align dowel pins on front timing chain case with the holes to install intake valve timing control covers.

FRONT TIMING CHAIN CASE

[VQ40DE]

< REMOVAL AND INSTALLATION >

e. Tighten bolts in numerical order as shown.

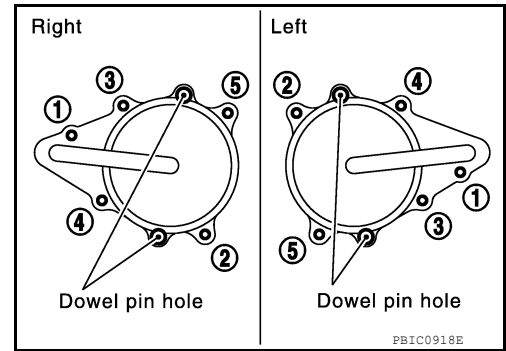

8. Install crankshaft pulley as follows:

- a. Install crankshaft pulley, taking care not to damage front oil seal.
 - When press-fitting crankshaft pulley with plastic hammer, tap on its center portion (not circumference).
- b. Tighten crankshaft pulley bolt in two steps.

Step 1 : 44.1 N·m (4.5 kg-m, 33 ft-lb)

Step 2 : 84° - 90° degrees clockwise

c. Remove Ring Gear Stopper Tool.

Tool number : KV11105210 (J-44716)

9. Rotate crankshaft pulley in normal direction (clockwise when viewed from front) to confirm it turns smoothly.

10. Installation of the remaining components is in the reverse order of removal.

INSPECTION AFTER INSTALLATION

- Before starting engine, check oil/fluid levels including engine coolant and engine oil. If less than required quantity, fill to the specified level. Refer to [MA-12. "Fluids and Lubricants"](#).
- Use procedure below to check for fuel leakage.
- Turn ignition switch ON (with engine stopped). With fuel pressure applied to fuel piping, check for fuel leakage at connection points.
- Start engine. With engine speed increased, check again for fuel leakage at connection points.
- Run engine to check for unusual noise and vibration.

NOTE:

If hydraulic pressure inside timing chain tensioner drops after removal and installation, slack in the guide may generate a pounding noise during and just after engine start. However, this is normal. Noise will stop after hydraulic pressure rises.

- Warm up engine thoroughly to make sure there is no leakage of fuel, exhaust gas, or any oils/fluids including engine oil and engine coolant.
- Bleed air from passages in lines and hoses, such as in cooling system.
- After cooling down engine, again check oil/fluid levels including engine oil and engine coolant. Refill to specified level, if necessary.
- Summary of the inspection items:

Item	Before starting engine	Engine running	After engine stopped
Engine coolant	Level	Leakage	Level
Engine oil	Level	Leakage	Level
Transmission/ transaxle fluid	A/T and CVT Models	Level/Leakage	Leakage
	M/T Models	Level/Leakage	Level/Leakage
Other oils and fluids*	Level	Leakage	Level
Fuel	Leakage	Leakage	Leakage
Exhaust gas	—	Leakage	—

*Power steering fluid, brake fluid, etc.

TIMING CHAIN

< REMOVAL AND INSTALLATION >

[VQ40DE]

TIMING CHAIN

Exploded View

INFOID:000000011069711

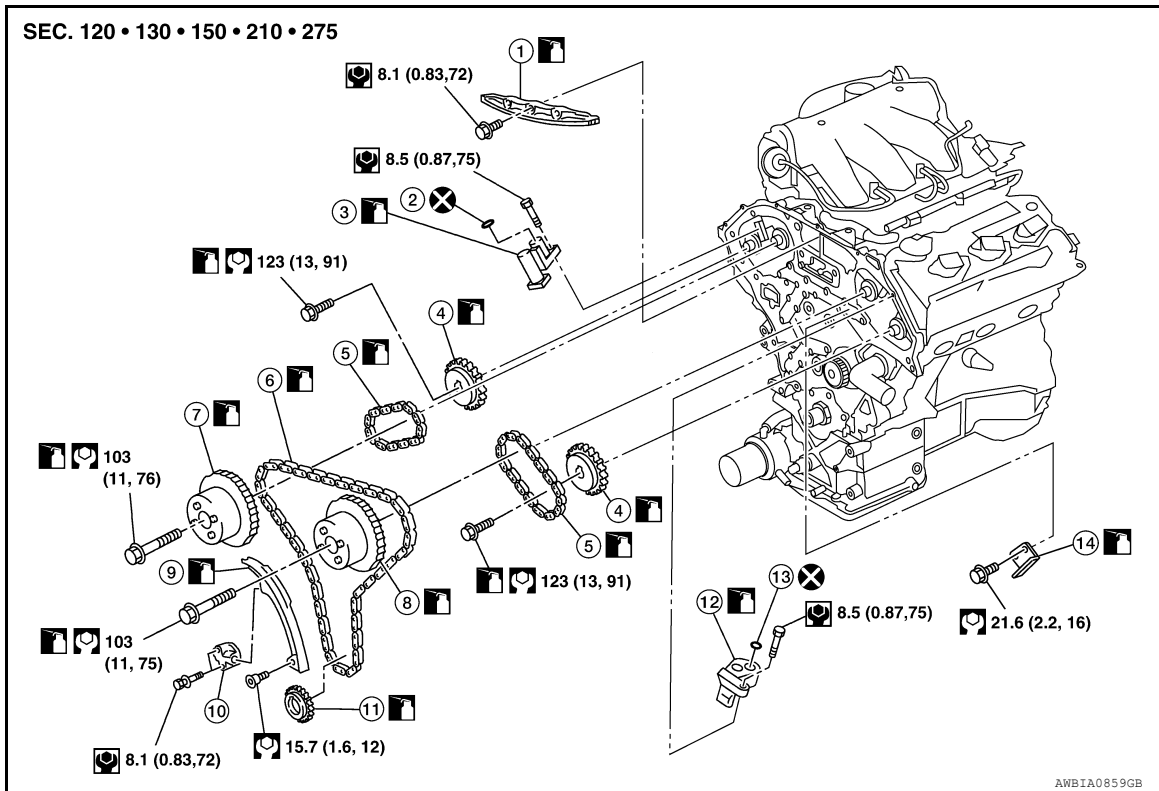

- | | | |
|--------------------------------------|-------------------------------|---------------------------------------------|
| 1. Internal chain guide | 2. O-ring | 3. Timing chain tensioner (secondary) (RH) |
| 4. Camshaft sprocket (EXH) | 5. Timing chain (secondary) | 6. Timing chain (primary) |
| 7. Camshaft sprocket RH (INT) | 8. Camshaft sprocket LH (INT) | 9. Slack guide |
| 10. Timing chain tensioner (primary) | 11. Crankshaft sprocket | 12. Timing chain tensioner (secondary) (LH) |
| 13. O-ring | 14. Tension guide | |

Removal and Installation

INFOID:000000011069712

CAUTION:

- After removing timing chains, do not turn the crankshaft and camshaft separately, or the valves will strike the pistons.
- When installing camshafts, chain tensioners, oil seals, or other sliding parts, lubricate contacting surfaces with new engine oil.
- Apply new engine oil to bolt threads and seat surfaces when installing camshaft sprockets, camshaft brackets, and crankshaft pulley.

NOTE:

It is not necessary to remove the rocker covers or intake manifold collector to remove or install the timing chain(s).

REMOVAL

TIMING CHAIN

[VQ40DE]

< REMOVAL AND INSTALLATION >

1. Set No. 1 cylinder to TDC.
 - Rotate crankshaft pulley clockwise to align timing mark (A) (grooved line without color) with timing indicator (B).

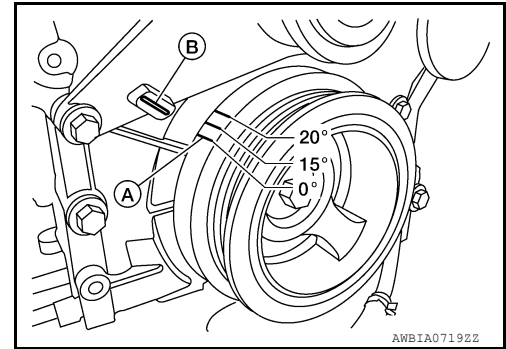

2. Remove front timing chain case. Refer to [EM-51. "Removal and Installation"](#).
3. Check timing chain markings to confirm No. 1 cylinder is at TDC of its compression stroke.
 - If not, remove Ring Gear Stopper Tool and turn crankshaft clockwise 360° (one revolution).
 - Re-install Ring Gear Stopper Tool.

Tool number : KV11105210 (J-44716)

- If the original timing chain markings are not legible, use paint or equivalent to mark the timing chains to the sprockets.
4. If removing the secondary timing chains, loosen camshaft sprocket bolts.

5. Compress the primary timing chain tensioner.
 1. Loosen clip of primary timing chain tensioner, and release plunger stopper (1).
 2. Depress plunger into tensioner body by pressing slack guide (2).
 3. Keep slack guide pressed and insert stopper pin through the tensioner body hole and plunger groove (3) to hold plunger in.

NOTE:

Use stopper pin included with Tool J-50246.

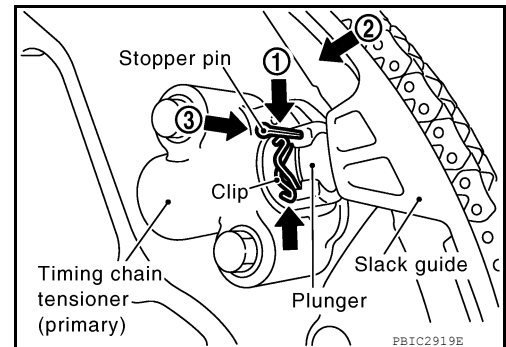

6. Remove internal chain guide.

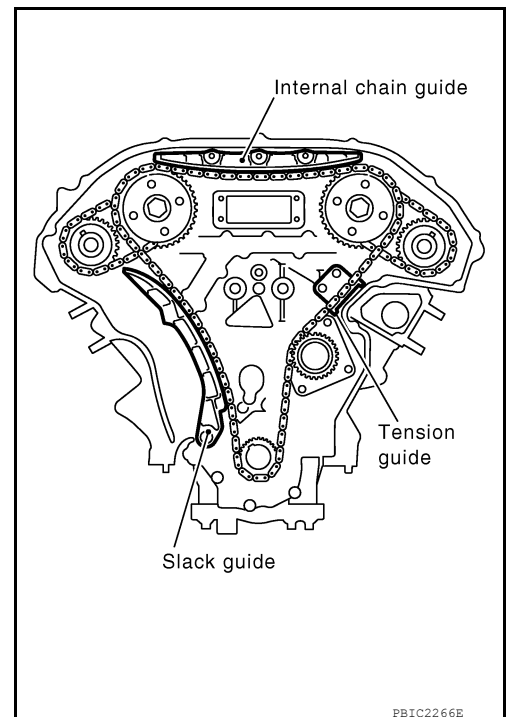

7. Remove timing chain (primary).

CAUTION:

TIMING CHAIN

< REMOVAL AND INSTALLATION >

[VQ40DE]

After removing timing chain (primary), do not turn crankshaft and camshaft separately, or valves will strike the piston heads.

8. Remove crankshaft sprocket, if necessary.
9. Remove timing chain (secondary) and camshaft sprockets as follows:
 - a. Attach stopper pin to the right and left timing chain tensioners (secondary).

NOTE:

- Use stopper pin included with Tool J-50246.

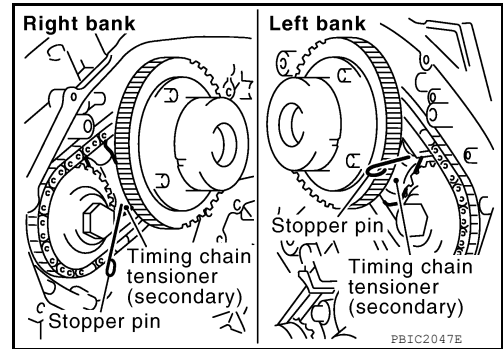

- b. Remove camshaft sprocket (INT and EXH) bolts.
- c. Remove timing chain (secondary) together with camshaft sprockets.
 - Turn camshaft slightly to secure slack of timing chain on timing chain tensioner (secondary) side.
 - Insert 0.5 mm (0.020 in)-thick metal or resin plate between timing chain and timing chain tensioner plunger (guide). Remove timing chain (secondary) together with camshaft sprockets with timing chain loose from guide groove.

CAUTION:

Be careful of plunger coming off when removing timing chain (secondary).

NOTE:

Camshaft sprocket (INT) is a one piece integrated design with sprockets for timing chain (primary) and for timing chain (secondary).

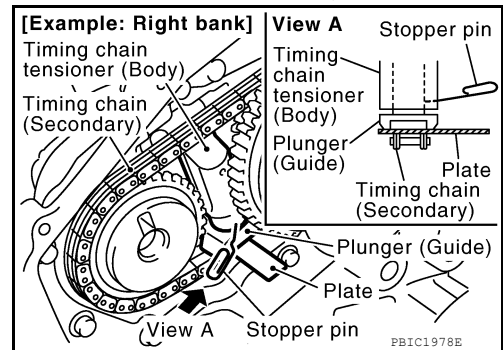

- When handling camshaft sprocket (INT), be careful of the following:

CAUTION:

- Handle carefully to avoid any shock to camshaft sprocket.
- Do not disassemble. (Do not loosen bolts (A) as shown).

NOTE:

For removal of timing chain tensioner (secondary), refer to [EM-68. "Removal and Installation \(Secondary Timing Chain Tensioner\)"](#). [Removing camshaft bracket (No. 1) is required.]

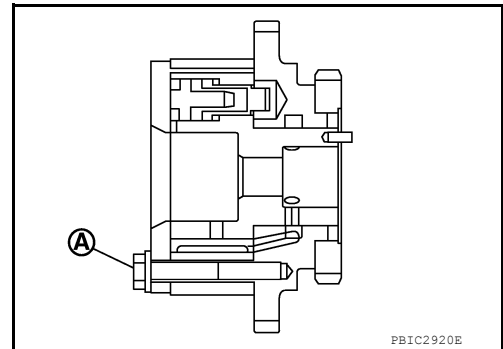

INSPECTION AFTER REMOVAL

Check for cracks and any excessive wear at link plates. Replace chain if necessary.

- Inspect all timing chains and associated parts for wear or damage, replace as necessary.

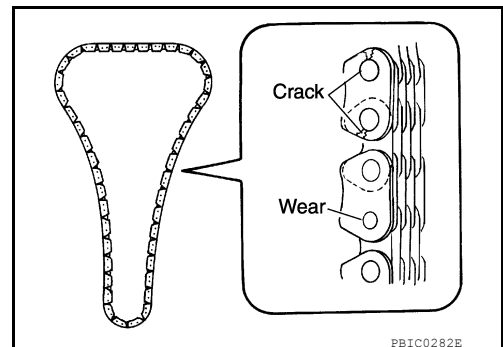

INSTALLATION

TIMING CHAIN

< REMOVAL AND INSTALLATION >

[VQ40DE]

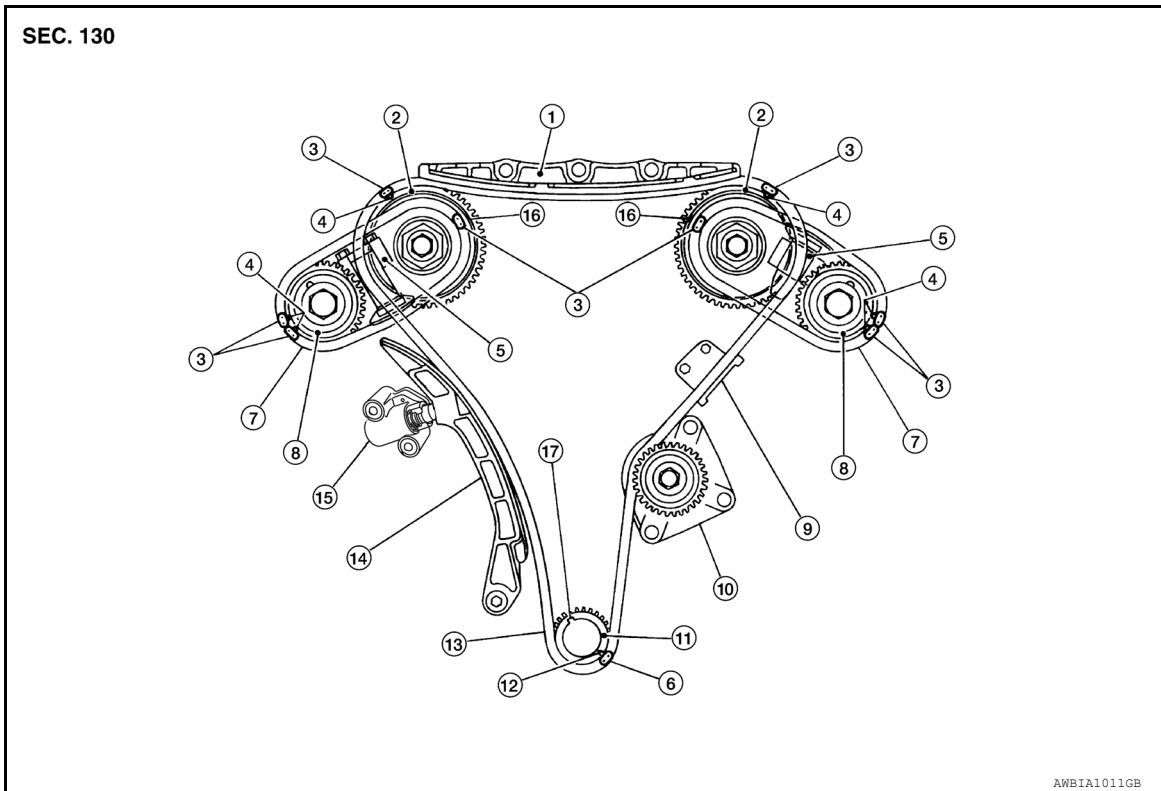

- | | | |
|-----------------------------|-------------------------------------|------------------------------------|
| 1. Internal chain guide | 2. Camshaft sprocket (intake) | 3. Mating mark (blue link) |
| 4. Mating mark (punched) | 5. Secondary timing chain tensioner | 6. Mating mark (copper link) |
| 7. Secondary timing chain | 8. Camshaft sprocket (exhaust) | 9. Tensioner guide |
| 10. Water pump | 11. Crankshaft sprocket | 12. Mating mark (notched) |
| 13. Primary timing chain | 14. Slack guide | 15. Primary timing chain tensioner |
| 16. Mating mark (back side) | 17. Crankshaft key | |

NOTE:

The figure above shows the relationship between the mating mark on each timing chain and that on the corresponding sprocket, with the components installed.

1. Make sure that dowel pin hole, dowel pin of camshaft and crankshaft key are located as shown. (No. 1 cylinder at compression TDC)

NOTE:

Though camshaft does not stop at the position as shown, for the placement of cam nose, it is generally accepted camshaft is placed for the same direction as the figure.

Camshaft dowel pin hole (intake side)

: At cylinder head upper face side in each bank.

Camshaft dowel pin (exhaust side)

: At cylinder head upper face side in each bank.

Crankshaft key

: At cylinder head side of right bank.

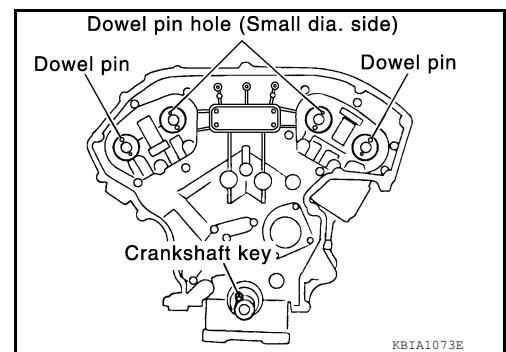

CAUTION:

Hole on small diameter side must be used for intake side dowel pin hole. Do not misidentify (ignore big diameter side).

2. Install timing chains (secondary) and camshaft sprockets as follows:

CAUTION:

TIMING CHAIN

< REMOVAL AND INSTALLATION >

[VQ40DE]

Mating marks between timing chain and sprockets slip easily. Confirm all mating mark positions repeatedly during the installation process.

- a. Push plunger of timing chain tensioner (secondary) and keep it pressed in with stopper pin.

NOTE:

Use stopper pin included with Tool J-50246.

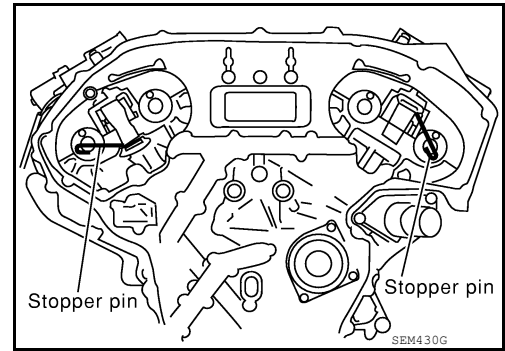

- b. Before installing timing chains (secondary) and camshaft sprockets, confirm mating marks are visible. If necessary, use paint or equivalent to re-mark the camshaft sprockets at each mating mark.

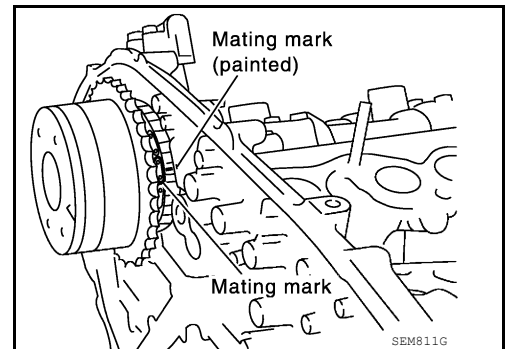

- c. Install timing chains (secondary) (8) and camshaft sprockets [INT (1) and EXH (9)].

- Left bank mating marks (6)
- Align the timing chain mating marks (secondary) (2) (blue color link) with the ones on camshaft sprockets (INT and EXH) (4), (5), (7) and (10) (punched), and install them.

NOTE:

- Mating marks for camshaft sprocket (INT) are on the back side of camshaft sprocket (secondary).
- There are two types of mating marks, circle (7), (10) and oval (4), (5) types. They should be used for the right and left banks, respectively.

Right bank : Use circle type (7) and (10).

Left bank : Use oval type (4) and (5).

- Align dowel pin (3) and pin hole on camshafts with the groove (11) and dowel pin on sprockets, and install them.
- On the intake side, align pin hole on the small diameter side of the camshaft front end with dowel pin (3) on the back side of camshaft sprocket, and install them.
- On the exhaust side, align dowel pin on camshaft front end with pin groove (11) on camshaft sprocket, and install them.
- In case that positions of each mating mark and each dowel pin do not fit on mating parts, make fine adjustment to the position by slightly turning camshaft(s).
- Bolts for camshaft sprockets must be tightened in the next step. Tightening them by hand is enough to prevent the dislocation of dowel pins.

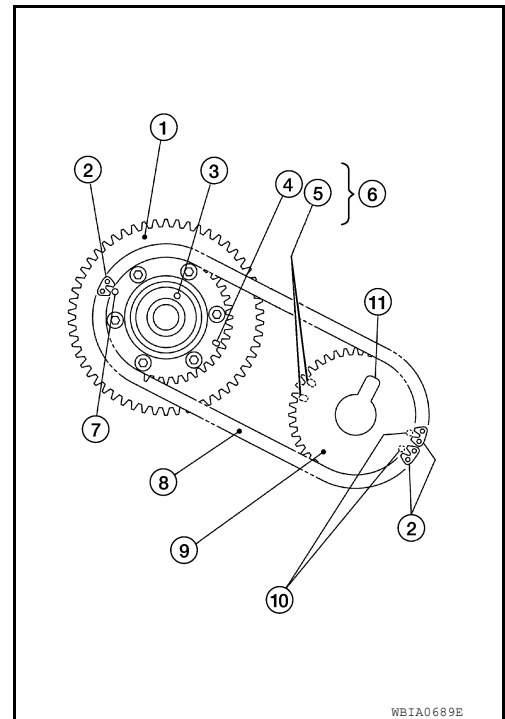

- d. Confirm the mating marks are aligned, then finger tighten camshaft sprocket bolts. Final tightening will be done with all timing chains installed.

TIMING CHAIN

< REMOVAL AND INSTALLATION >

[VQ40DE]

- e. Remove stopper pins out from timing chain tensioners (secondary).

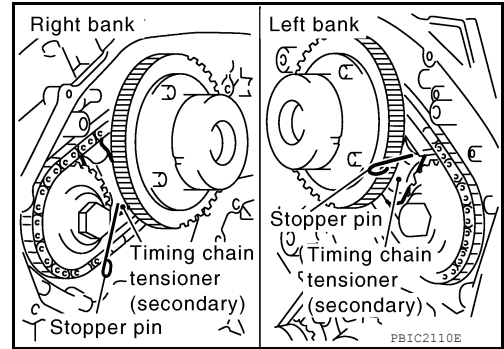

3. Install timing chain (primary) as follows:

- a. Install crankshaft sprocket.
- Make sure the mating marks on crankshaft sprocket face the front of engine.

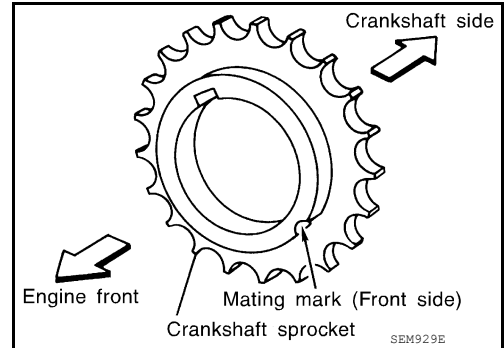

- b. Install the primary timing chain.
- Water pump (G).
 - Install primary timing chain so the mating mark punched (B) on camshaft sprocket is aligned with the blue link (A) on the timing chain, while the mating mark notched (E) on the crankshaft sprocket (D) is aligned with the copper link (F) on the timing chain, as shown.
 - When it is difficult to align mating marks (A) with (B) and (E) with (F) of the primary timing chain with each sprocket, gradually turn the camshaft to align it with the mating marks.
 - During alignment, be careful to prevent dislocation of mating mark alignments of the secondary timing chains.

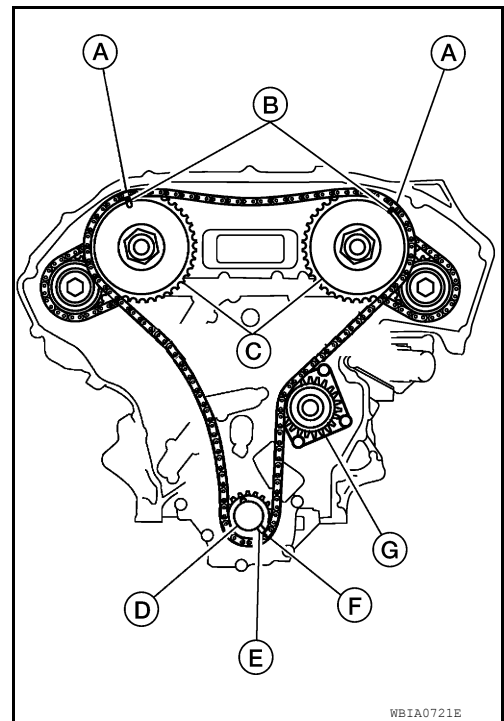

TIMING CHAIN

< REMOVAL AND INSTALLATION >

[VQ40DE]

4. Install internal chain guide.

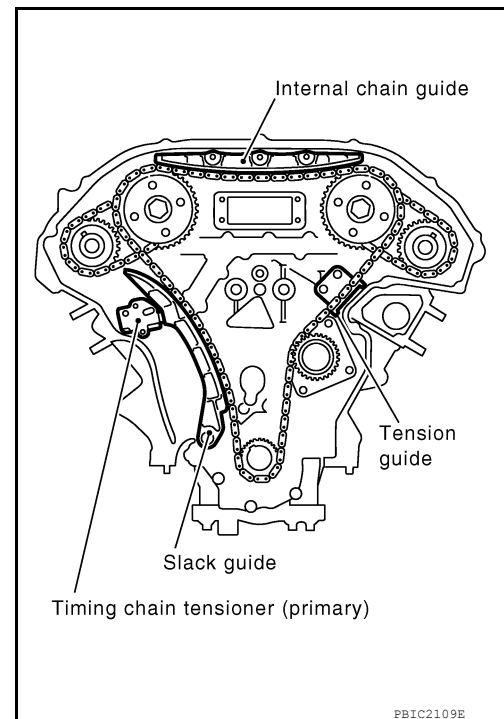

- If removed, reinstall slack guide.

CAUTION:

Do not overtighten slack guide bolts. It is normal for a gap to exist under the bolt seats when bolts are tightened to specification.

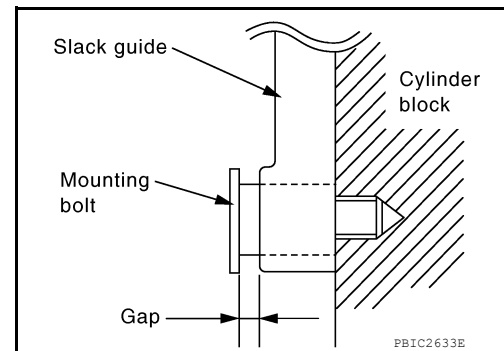

5. Remove stopper pin from primary timing chain tensioner.
6. Make sure again that the mating marks on camshaft sprockets and timing chain have not slipped out of alignment.
7. Tighten camshaft sprocket bolts to specification with all timing chains installed and Ring Gear Stopper Tool holding the crankshaft.

Tool number : KV11105210 (J-44716)

8. Install front timing chain case. Refer to [EM-51. "Removal and Installation"](#).

INSPECTION AFTER INSTALLATION

- Before starting engine, check oil/fluid levels including engine coolant and engine oil. If less than required quantity, fill to the specified level. Refer to [MA-12. "Fluids and Lubricants"](#).
- Use procedure below to check for fuel leakage.
- Turn ignition switch ON (with engine stopped). With fuel pressure applied to fuel piping, check for fuel leakage at connection points.
- Start engine. With engine speed increased, check again for fuel leakage at connection points.
- Run engine to check for unusual noise and vibration.

NOTE:

If hydraulic pressure inside timing chain tensioner drops after removal and installation, slack in the guide may generate a pounding noise during and just after engine start. However, this is normal. Noise will stop after hydraulic pressure rises.

- Warm up engine thoroughly to make sure there is no leakage of fuel, exhaust gas, or any oils/fluids including engine oil and engine coolant.

TIMING CHAIN

< REMOVAL AND INSTALLATION >

[VQ40DE]

- Bleed air from passages in lines and hoses, such as in cooling system.
- After cooling down engine, again check oil/fluid levels including engine oil and engine coolant. Refill to specified level, if necessary.
- Summary of the inspection items:

Item		Before starting engine	Engine running	After engine stopped
Engine coolant		Level	Leakage	Level
Engine oil		Level	Leakage	Level
Transmission/ transaxle fluid	A/T and CVT Models	Leakage	Level/Leakage	Leakage
	M/T Models	Level/Leakage	Leakage	Level/Leakage
Other oils and fluids*		Level	Leakage	Level
Fuel		Leakage	Leakage	Leakage
Exhaust gas		—	Leakage	—

*Power steering fluid, brake fluid, etc.

TIMING CHAIN TENSIONER

< REMOVAL AND INSTALLATION >

[VQ40DE]

TIMING CHAIN TENSIONER

Exploded View

INFOID:000000011069713

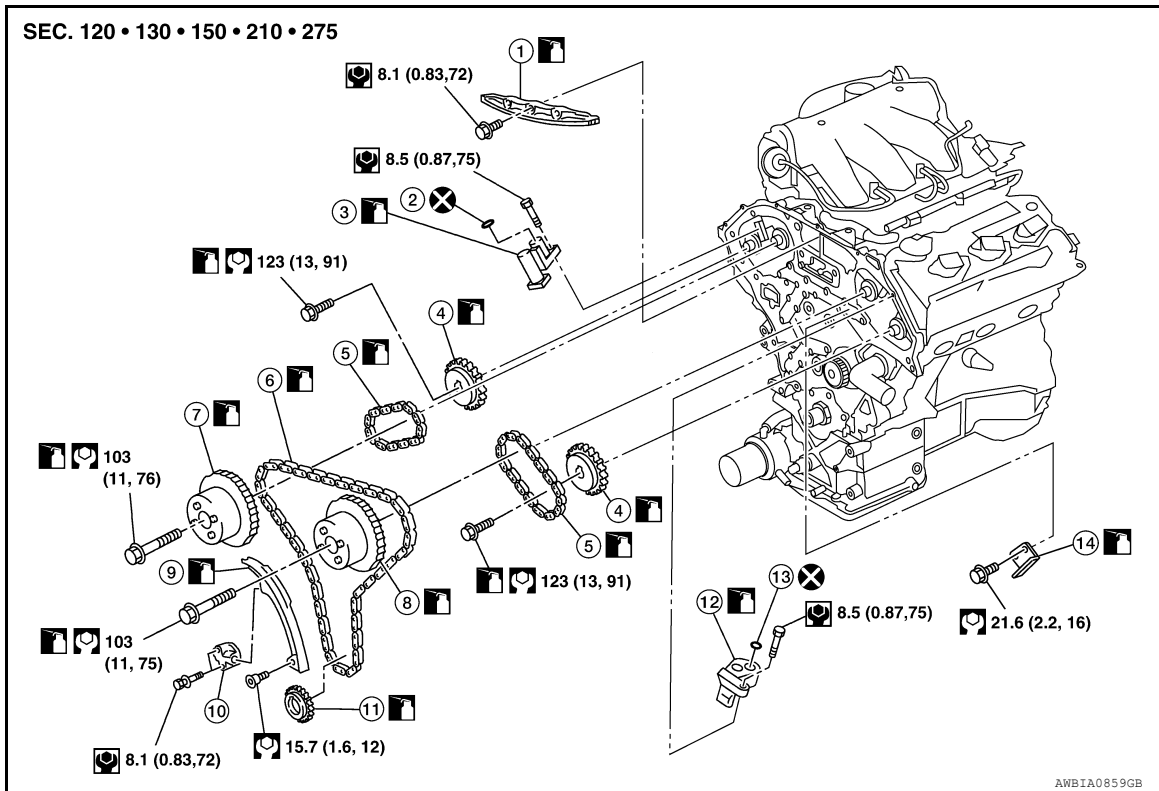

- | | | |
|--------------------------------------|-------------------------------|---------------------------------------------|
| 1. Internal chain guide | 2. O-ring | 3. Timing chain tensioner (secondary) (RH) |
| 4. Camshaft sprocket (EXH) | 5. Timing chain (secondary) | 6. Timing chain (primary) |
| 7. Camshaft sprocket RH (INT) | 8. Camshaft sprocket LH (INT) | 9. Slack guide |
| 10. Timing chain tensioner (primary) | 11. Crankshaft sprocket | 12. Timing chain tensioner (secondary) (LH) |
| 13. O-ring | 14. Tension guide | |

Removal and Installation (Primary Timing Chain Tensioner)

INFOID:000000011069714

NOTE:

When removing components such as hoses, tubes/lines, etc., cap or plug openings to prevent fluid from spilling.

REMOVAL

1. Remove engine under cover. Refer to [EXT-15, "Removal and Installation"](#).
2. Partially drain engine coolant. Refer to [CO-11, "Changing Engine Coolant"](#).
3. Remove lower fan shroud. Refer to [CO-15, "Exploded View"](#).
4. Disconnect crankcase ventilation hose and remove air duct and resonator assembly. Refer to [EM-24, "Removal and Installation"](#).
5. Disconnect mass air flow sensor and remove air cleaner case (upper). Refer to [EM-24, "Removal and Installation"](#).
6. Remove coolant reservoir hose.
7. Disconnect upper radiator hose from radiator.
8. Disconnect and remove engine cooling fan (Motor driven type). Refer to [CO-19, "Removal and Installation \(Motor driven type\)"](#).
9. Remove upper fan shroud. Refer to [CO-15, "Exploded View"](#).
10. Remove drive belt. Refer to [EM-13, "Removal and Installation"](#).

TIMING CHAIN TENSIONER

< REMOVAL AND INSTALLATION >

[VQ40DE]

11. Remove drive belt auto-tensioner. Refer to [EM-14, "Drive Belt Auto-Tensioner and Idler Pulley"](#).
12. Remove chain tensioner cover.
13. Remove timing chain tensioner (primary) as follows:
 - a. Loosen clip of timing chain tensioner (primary), and release plunger stopper (1).
 - b. Depress plunger into tensioner body by pressing slack guide (2).
 - c. Keep slack guide pressed and insert stopper pin through the tensioner body hole and plunger groove (3) to hold plunger in.
 - Use stopper pin included with Tool J-50246.

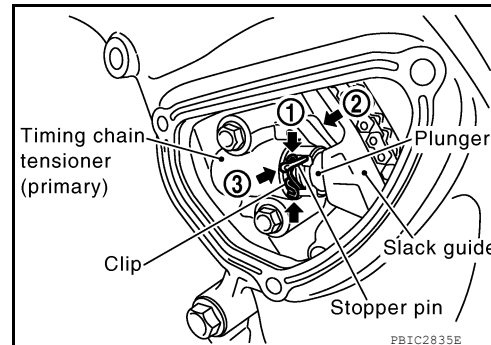

- d. Remove timing chain tensioner bolts and remove timing chain tensioner (primary).

CAUTION:

Be careful not to drop timing chain tensioner bolts inside timing chain case.

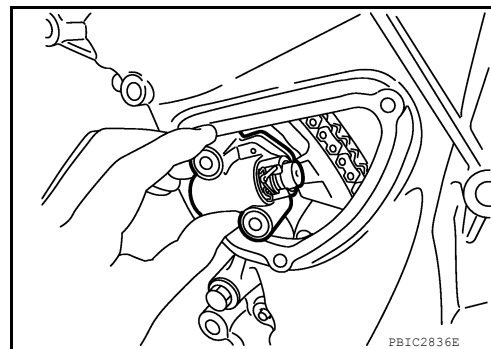

INSTALLATION

Installation is in the reverse order of removal.

- When installing timing chain tensioner (primary), push in plunger and keep it pressed in with stopper pin.
- Remove any dirt and foreign materials completely from the back and the mounting surfaces of primary timing chain tensioner.
- After installation, pull out stopper pin.

Removal and Installation (Secondary Timing Chain Tensioner)

INFOID:000000011069715

REMOVAL

1. Remove the timing chains (primary) and (secondary). Refer to [EM-59, "Removal and Installation"](#).
2. Remove the rocker covers. Refer to [EM-41, "Removal and Installation"](#).
3. Remove the camshaft brackets (No. 1). Refer to [EM-76, "Removal and Installation"](#).
4. Remove the secondary timing chain tensioners.

INSTALLATION

Installation is in the reverse order of removal.

Removal and Installation (Secondary Timing Chain Tensioner Shoe)

INFOID:000000011069716

REMOVAL

1. Remove the timing chains (secondary). Refer to [EM-59, "Removal and Installation"](#).

TIMING CHAIN TENSIONER

< REMOVAL AND INSTALLATION >

[VQ40DE]

2. Remove the secondary timing chain tensioner shoe by evenly prying at base of shoe with suitable tool as shown.

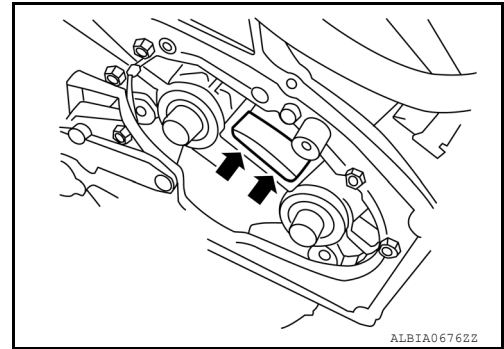

INSTALLATION

1. Install new secondary timing chain tensioner shoe using Tool (A) as shown.
 - Tighten the bolt until the secondary timing chain tensioner shoe is fully seated on the secondary timing chain tensioner.

CAUTION:

Do not overtighten bolt.

Tool number : — (J-50246)

2. Installation of the remaining components is in the reverse order of removal.

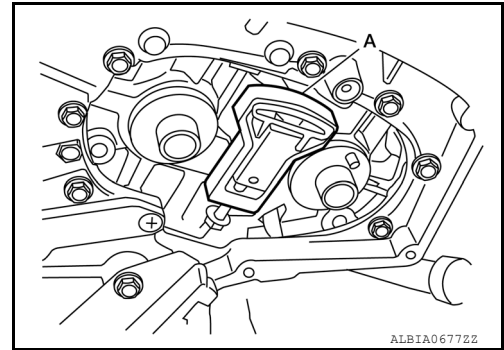

A

EM

C

D

E

F

G

H

I

J

K

L

M

N

O

P

REAR TIMING CHAIN CASE

< REMOVAL AND INSTALLATION >

[VQ40DE]

REAR TIMING CHAIN CASE

Exploded View

INFOID:000000011069717

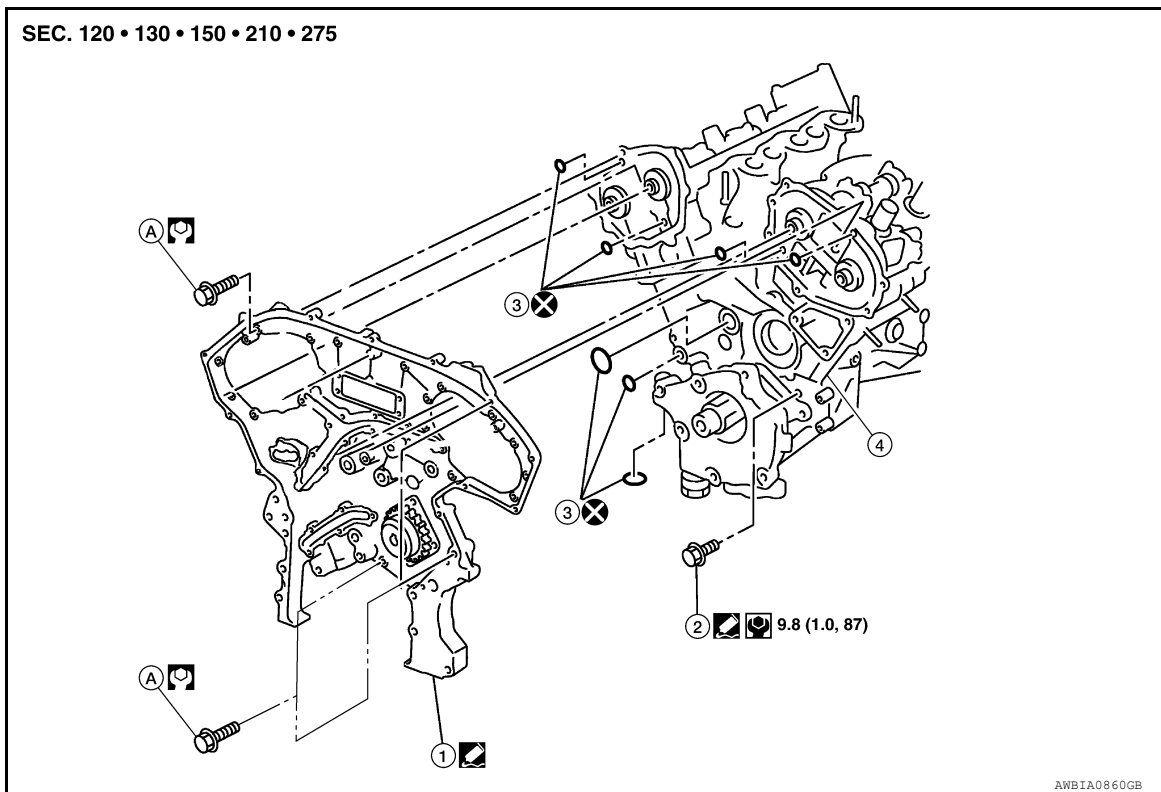

- | | | |
|---------------------------|-----------------------------|------------|
| 1. Rear timing chain case | 2. Water drain plug (front) | 3. O-rings |
| 4. Cylinder block | A. Refer to installation | |

Removal and Installation

INFOID:000000011069718

CAUTION:

- After removing timing chain, do not turn the crankshaft and camshaft separately, or the valves will strike the pistons.
- Before removing the upper oil pan, remove the crankshaft position sensor (POS).
- Be careful not to damage sensor edges.

REMOVAL

1. Remove oil pan (lower) and (upper). Refer to [EM-34, "Removal and Installation"](#).
2. Remove front timing chain case. Refer to [EM-51, "Removal and Installation"](#).
3. Remove timing chains and related components. Refer to [EM-59, "Removal and Installation"](#) and [EM-68, "Removal and Installation \(Secondary Timing Chain Tensioner\)"](#).
4. Remove water pump, if necessary. Refer to [CO-21, "Removal and Installation"](#).
5. Remove rear timing chain case as follows:

REAR TIMING CHAIN CASE

[VQ40DE]

< REMOVAL AND INSTALLATION >

- Loosen and remove bolts using power tool in reverse order as shown.
- Cut liquid gasket using Tool and remove rear timing chain case.

Tool number : KV10111100 (J-37228)

CAUTION:

Do not damage the mating surfaces.

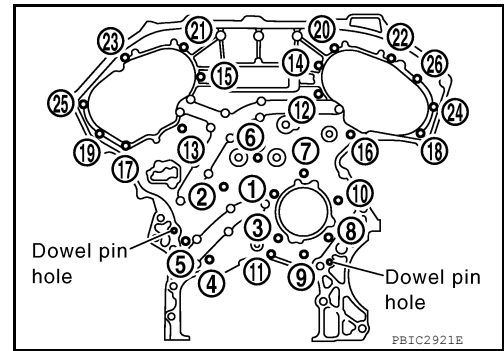

CAUTION:

- Do not remove plate metal cover of oil passage.
- After removal, handle rear timing chain case carefully so it does not twist, bend, or warp under a load.

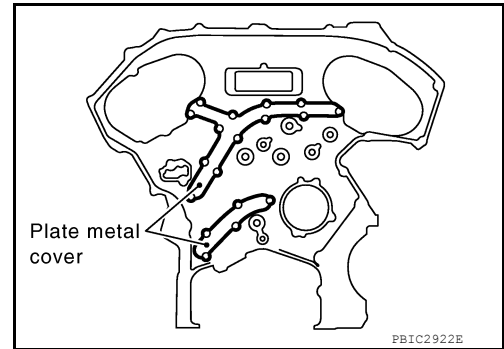

- Remove O-rings from cylinder head and camshaft bracket (No. 1).

CAUTION:

Do not reuse O-rings.

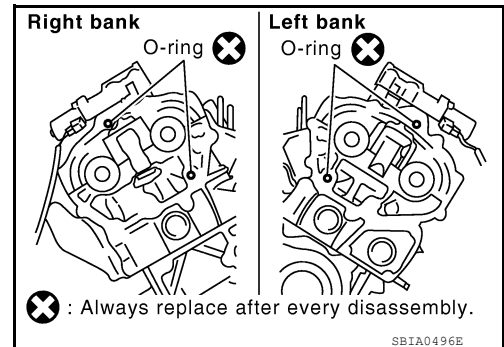

- Remove O-rings from cylinder block.

CAUTION:

Do not reuse O-rings.

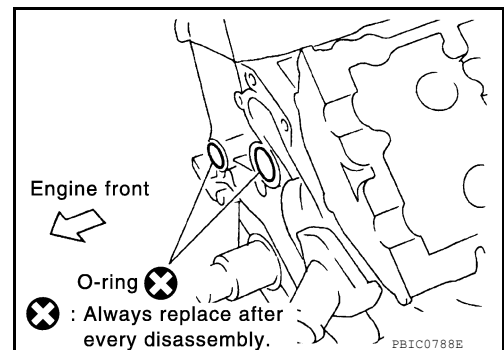

A
EM
C
D
E
F
G
H
I
J
K
L
M
N
O
P

REAR TIMING CHAIN CASE

[VQ40DE]

< REMOVAL AND INSTALLATION >

8. Use scraper to remove all traces of old liquid gasket from rear timing chain case, and opposite mating surfaces.

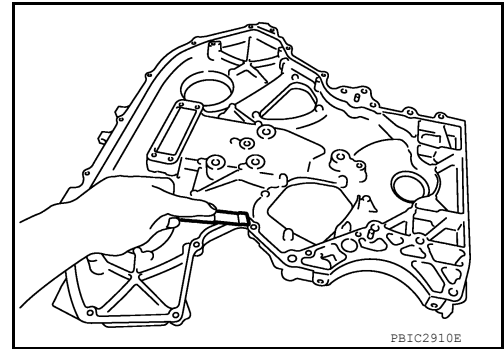

- Remove old liquid gasket from bolt hole and thread.

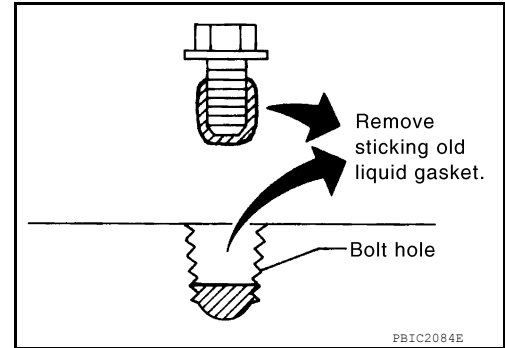

INSTALLATION

1. Install rear timing chain case as follows:
 - a. Install new O-rings onto cylinder block.

CAUTION:
Do not reuse O-rings.

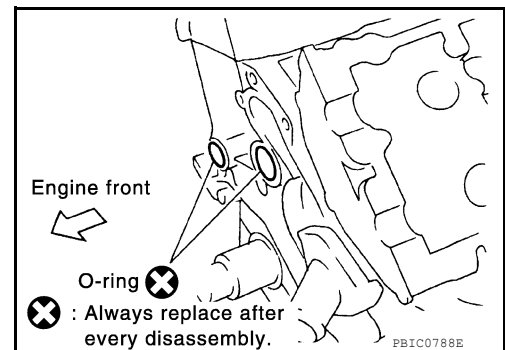

- b. Install new O-rings to cylinder head and camshaft bracket (No. 1).

CAUTION:
Do not reuse O-rings.

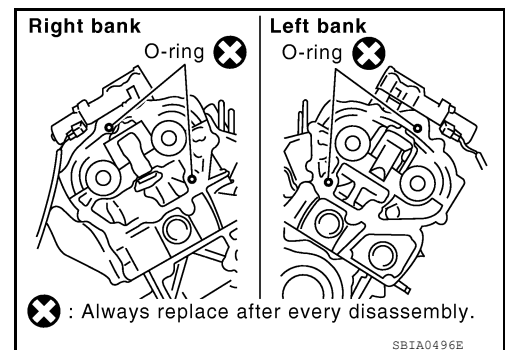

- c. Apply liquid gasket using suitable tool to rear timing chain case back side as shown. Use Genuine RTV Silicone Sealant or equivalent. Refer to [GI-21, "Recommended Chemical Products and Sealants"](#).

CAUTION:
• For "A", completely wipe off liquid gasket covering the area shown.

REAR TIMING CHAIN CASE

< REMOVAL AND INSTALLATION >

[VQ40DE]

- Apply liquid gasket on installation position of water pump and cylinder head very completely.

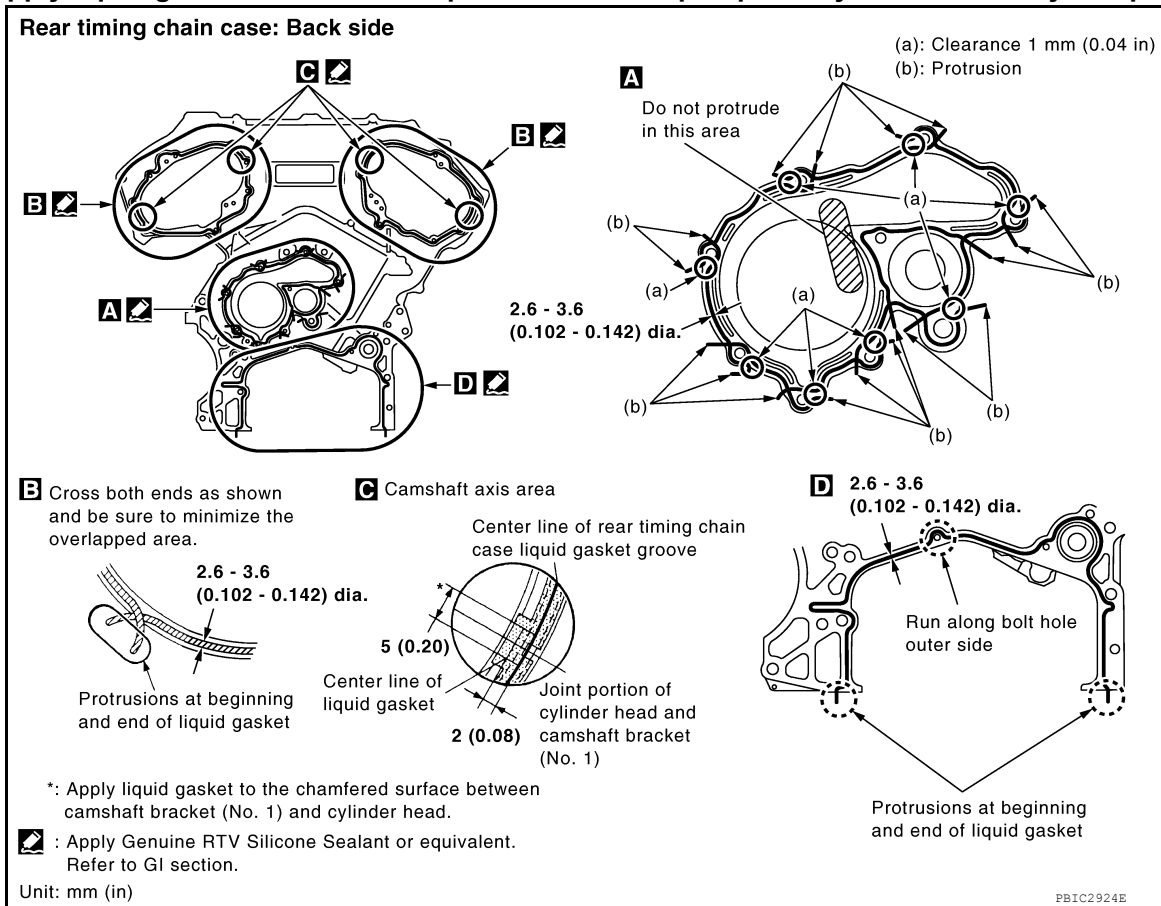

- d. Align rear timing chain case with dowel pins (right and left) on cylinder block and install rear timing chain case.
- Make sure O-rings stay in place during installation to cylinder block, cylinder head and camshaft bracket (No. 1).

CAUTION:

Do not reuse O-rings.

- e. Tighten bolts in numerical order as shown.
- There are two type of bolts with different torque specifications. Refer to the following for installing bolts.

Bolt length	Bolt position	Torque specification
20 mm (0.79 in)	1, 2, 3, 6, 7, 8, 9, 10	: 12.7 N·m (1.3 kg·m, 9 ft·lb)
16 mm (0.63 in)	4, 5, 11	: 12.7 N·m (1.3 kg·m, 9 ft·lb)
16 mm (0.63 in)	12 through 26	: 15.0 N·m (1.5 kg·m, 11 ft·lb)

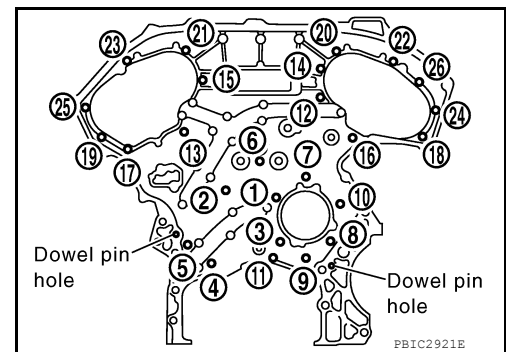

- f. After all bolts are tightened, retighten them to the specified torque in numerical order as shown.
- If liquid gasket protrudes, wipe it off immediately.

REAR TIMING CHAIN CASE

< REMOVAL AND INSTALLATION >

[VQ40DE]

- g. After installing rear timing chain case, check the surface height difference between following parts on oil pan (upper) mounting surface.

Standard

**Rear timing chain case to lower cylinder block:
-0.24 to 0.14 mm (-0.0094 to 0.0055 in)**

- If not within the standard, repeat the installation procedure.

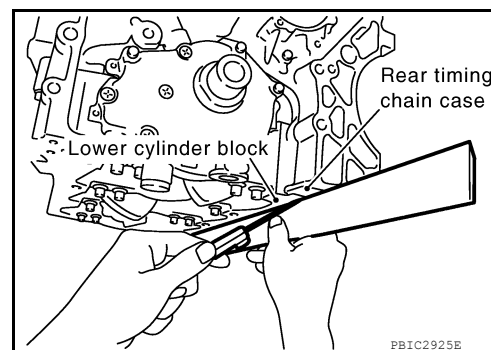

2. Install water pump with new O-rings, if removed. Refer to [CO-21. "Removal and Installation"](#).
CAUTION:
Do not reuse O-rings.
3. Install timing chains and related components. Refer to [EM-59. "Removal and Installation"](#) and [EM-68. "Removal and Installation \(Secondary Timing Chain Tensioner\)"](#).
4. Install front timing chain case. Refer to [EM-51. "Removal and Installation"](#).
5. Install oil pan (upper) and (lower). Refer to [EM-34. "Removal and Installation"](#).

INSPECTION AFTER INSTALLATION

- Before starting engine, check oil/fluid levels including engine coolant and engine oil. If less than required quantity, fill to the specified level. Refer to [MA-12. "Fluids and Lubricants"](#).
- Use procedure below to check for fuel leakage.
- Turn ignition switch ON (with engine stopped). With fuel pressure applied to fuel piping, check for fuel leakage at connection points.
- Start engine. With engine speed increased, check again for fuel leakage at connection points.
- Run engine to check for unusual noise and vibration.

NOTE:

If hydraulic pressure inside timing chain tensioner drops after removal and installation, slack in the guide may generate a pounding noise during and just after engine start. However, this is normal. Noise will stop after hydraulic pressure rises.

- Warm up engine thoroughly to make sure there is no leakage of fuel, exhaust gas, or any oils/fluids including engine oil and engine coolant.
- Bleed air from passages in lines and hoses, such as in cooling system.
- After cooling down engine, again check oil/fluid levels including engine oil and engine coolant. Refill to specified level, if necessary.
- Summary of the inspection items:

Item		Before starting engine	Engine running	After engine stopped
Engine coolant		Level	Leakage	Level
Engine oil		Level	Leakage	Level
Transmission/ transaxle fluid	A/T and CVT Models	Leakage	Level/Leakage	Leakage
	M/T Models	Level/Leakage	Leakage	Level/Leakage
Other oils and fluids*		Level	Leakage	Level
Fuel		Leakage	Leakage	Leakage
Exhaust gas		—	Leakage	—

*Power steering fluid, brake fluid, etc.

CAMSHAFT

< REMOVAL AND INSTALLATION >

[VQ40DE]

CAMSHAFT

Exploded View

INFOID:000000011069719

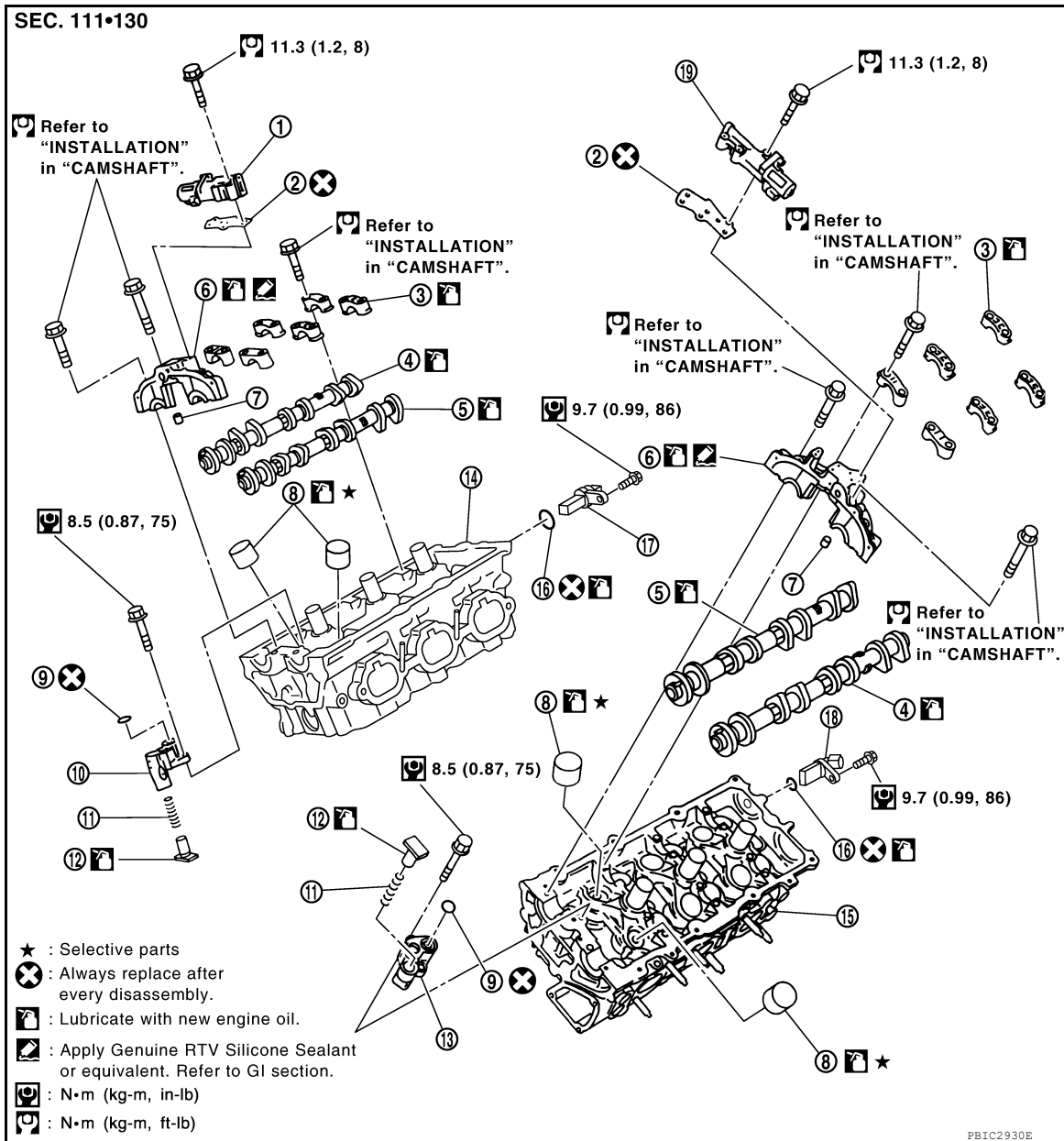

- | | | |
|----------------------------------------------------------|------------------------------------------------|------------------------------------------------|
| 1. Intake valve timing control solenoid valve (RH bank) | 2. Gasket | 3. Camshaft bracket (No. 2 to 4) |
| 4. Camshaft (EXH) | 5. Camshaft (INT) | 6. Camshaft bracket (No. 1) |
| 7. Dowel pin | 8. Valve lifter | 9. O-ring |
| 10. Timing chain tensioner (secondary) (RH bank) | 11. Spring | 12. Plunger |
| 13. Timing chain tensioner (secondary) (LH bank) | 14. Cylinder head (RH bank) | 15. Cylinder head (LH bank) |
| 16. O-ring | 17. Camshaft position sensor (PHASE) (RH bank) | 18. Camshaft position sensor (PHASE) (LH bank) |
| 19. Intake valve timing control solenoid valve (LH bank) | | |

A
C
D
E
F
G
H
I
J
K
L
M
N
O
P

EM

Removal and Installation

REMOVAL

1. Release the fuel pressure. Refer to [EC-502, "Fuel Pressure Check"](#).
2. Disconnect the battery negative terminal. Refer to [PG-77, "Removal and Installation"](#).
3. Remove front wheels and tires. Refer to [WT-48, "Adjustment"](#).
4. Remove front fender protectors. Refer to [EXT-22, "Removal and Installation"](#).
5. Remove intake manifold collector. Refer to [EM-25, "Removal and Installation"](#).
6. Remove rocker covers. Refer to [EM-41, "Removal and Installation"](#).
7. Remove front timing chain case, camshaft sprockets, timing chains and rear timing chain case. Refer to [EM-51, "Removal and Installation"](#) and [EM-76, "Removal and Installation"](#) and [EM-59, "Removal and Installation"](#) and [EM-70, "Removal and Installation"](#).
8. Remove camshaft position sensor (PHASE) (right and left banks) from cylinder head back side.

CAUTION:

- Handle carefully to avoid dropping and shocks.
- Do not disassemble.
- Do not allow metal powder to adhere to magnetic part at sensor tip.
- Do not place sensors in a location where they are exposed to magnetism.

Example: Left bank

Keep off any magnetic materials.

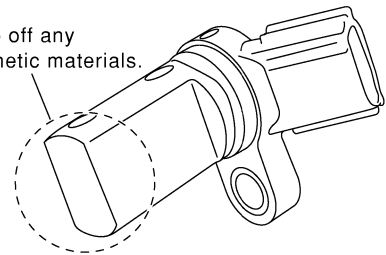

KBIA1046E

9. Remove intake valve timing control solenoid valves.
 - Discard intake valve timing control solenoid valve gaskets and use new gaskets for installation.

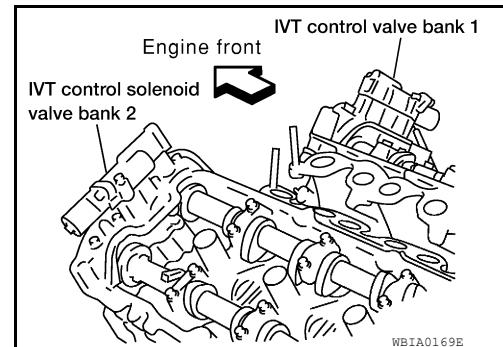

WBIA0169E

10. Remove camshaft brackets.
 - Mark camshafts, camshaft brackets and bolts so they are placed in the same position and direction for installation.

CAMSHAFT

[VQ40DE]

< REMOVAL AND INSTALLATION >

- Equally loosen camshaft bracket bolts in several steps in reverse order as shown.

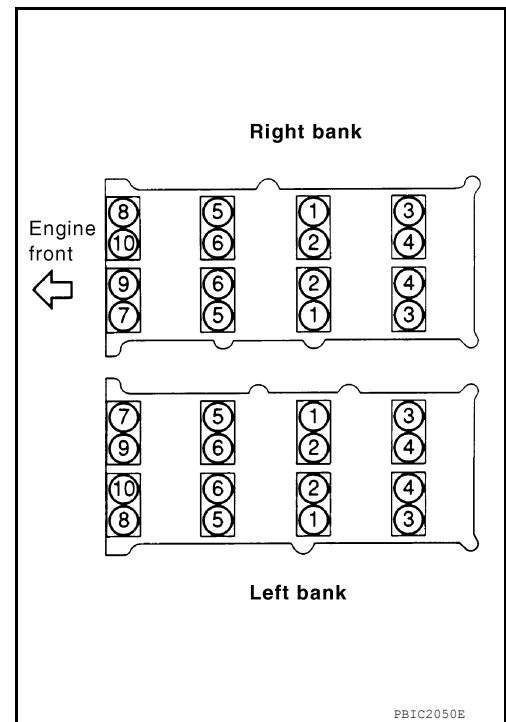

- Remove camshafts.
- Remove valve lifters, if necessary.
 - Identify installation positions, and store them without mixing them up.
- Remove timing chain tensioner (secondary) from cylinder head.
 - Remove timing chain tensioner (secondary) with its stopper pin attached.

NOTE:

Stopper pin was attached when timing chain (secondary) was removed.

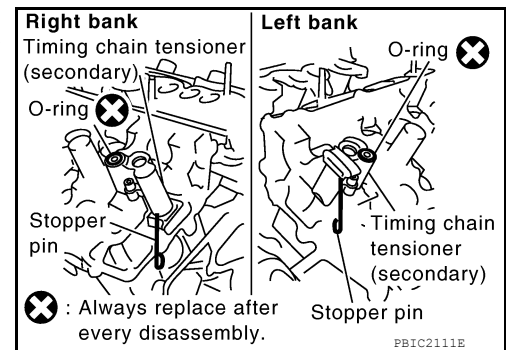

INSPECTION AFTER REMOVAL

Camshaft Runout

- Put V-block on precise flat table, and support No. 2 and 4 journal of camshaft.

CAUTION:
Do not support journal No. 1 (on the side of camshaft sprocket) because it has a different diameter from the other three locations.
- Set dial indicator vertically to No. 3 journal.
- Turn camshaft to one direction with hands, and measure the camshaft runout on dial indicator. (Total indicator reading)

Standard : Less than 0.02 mm (0.0008 in)

Limit : 0.05 mm (0.0020 in)

- If it exceeds the limit, replace camshaft.

Camshaft Cam Height

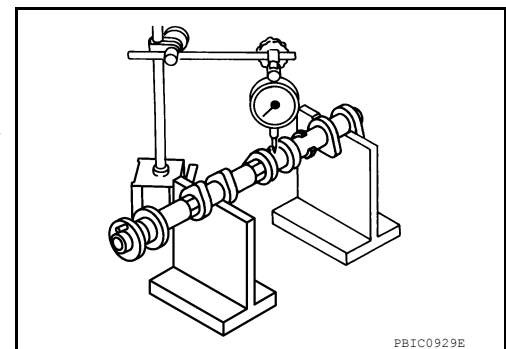

CAMSHAFT

< REMOVAL AND INSTALLATION >

[VQ40DE]

1. Measure the camshaft cam height with micrometer.

Standard:

Intake : 45.465 - 45.655 mm (1.7900 - 1.7974 in)

Exhaust : 45.075 - 45.265 mm (1.7746 - 1.7821 in)

Limit:

Intake : 45.265 mm (1.7821 in)

Exhaust : 44.875 mm (1.7667 in)

2. If wear exceeds the limit, replace camshaft.

Camshaft Journal Oil Clearance

CAMSHAFT JOURNAL DIAMETER

- Measure the outer diameter of camshaft journal with micrometer.

Standard:

No. 1 : 25.935 - 25.955 mm (1.0211 - 1.0218 in)

No. 2, 3, 4 : 23.445 - 23.465 mm (0.9230 - 0.9238 in)

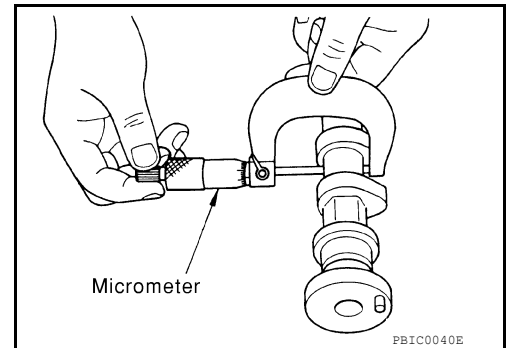
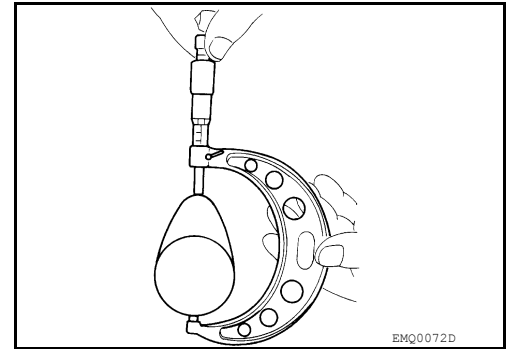

CAMSHAFT BRACKET INNER DIAMETER

- Tighten camshaft bracket bolt with the specified torque.
- Measure the inner diameter "A" of camshaft bracket with bore gauge.

Standard:

No. 1 : 26.000 - 26.021 mm (1.0236 - 1.0244 in)

No. 2, 3, 4 : 23.500 - 23.521 mm (0.9252 - 0.9260 in)

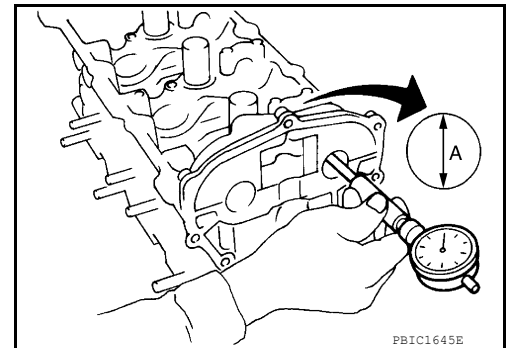

CAMSHAFT JOURNAL OIL CLEARANCE

- (Oil clearance) = (Camshaft bracket inner diameter) – (Camshaft journal diameter).

Standard:

No. 1 : 0.045 - 0.086 mm (0.0018 - 0.0034 in)

No. 2, 3, 4 : 0.035 - 0.076 mm (0.0014 - 0.0030 in)

Limit : 0.15 mm (0.0059 in)

- If the calculated value exceeds the limit, replace either or both camshaft and cylinder head.

NOTE:

Camshaft bracket cannot be replaced as a single part, because it is machined together with cylinder head. Replace whole cylinder head assembly.

Camshaft End Play

CAMSHAFT

[VQ40DE]

< REMOVAL AND INSTALLATION >

- Install dial indicator in thrust direction on front end of camshaft. Measure the end play of dial indicator when camshaft is moved forward/backward (in direction to axis).

Standard : 0.115 - 0.188 mm (0.0045 - 0.0074 in)
Limit : 0.24 mm (0.0094 in)

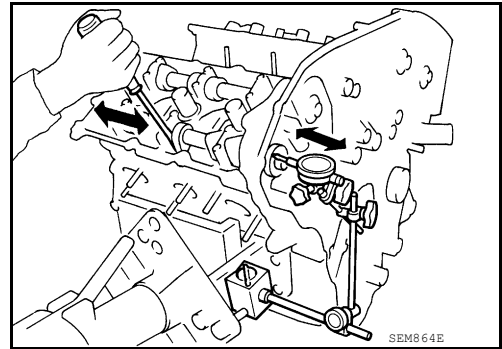

- Measure the following parts if out of the limit.
 - Dimension "A" for camshaft No. 1 journal

Standard : 27.500 - 27.548 mm (1.0827 - 1.0846 in)

- Dimension "B" for cylinder head No. 1 journal bearing

Standard : 27.360 - 27.385 mm (1.0772 - 1.0781 in)

- Following the standards above, replace camshaft and/or cylinder head.

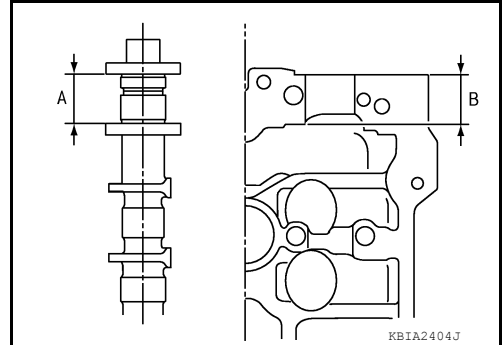

Camshaft Sprocket Runout

1. Put V-block on precise flat table, and support No. 2 and 4 journal of camshaft.

CAUTION:

Do not support journal No. 1 (on the side of camshaft sprocket) because it has a different diameter from the other three locations.

2. Measure the camshaft sprocket runout with dial indicator. (Total indicator reading)

Limit : 0.15 mm (0.0059 in)

- If it exceeds the limit, replace camshaft sprocket.

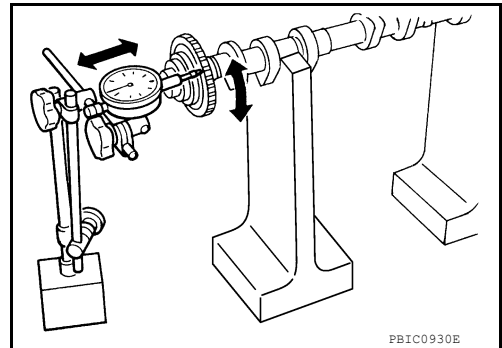

Valve Lifter

Check if surface of valve lifter has any wear or cracks.

- If anything above is found, replace valve lifter. Refer to [EM-130](#), "[Standard and Limit](#)".

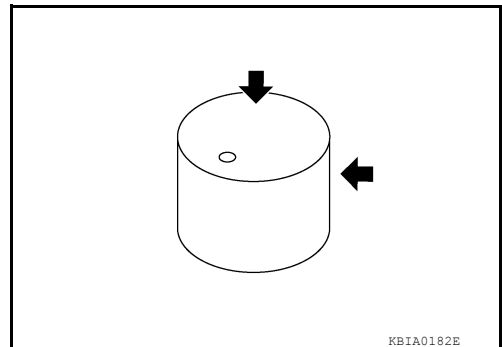

Valve Lifter Clearance

VALVE LIFTER OUTER DIAMETER

CAMSHAFT

[VQ40DE]

< REMOVAL AND INSTALLATION >

- Measure the outer diameter at 1/2 height of valve lifter with micrometer since valve lifter is in barrel shape.

Standard (Intake and exhaust)

: 33.977 - 33.987 mm (1.3377 - 1.3381 in)

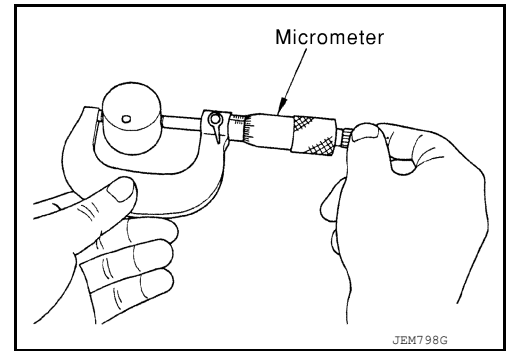

VALVE LIFTER HOLE DIAMETER

- Measure the inner diameter of valve lifter hole of cylinder head with inside micrometer.

Standard (Intake and exhaust)

: 34.000 - 34.016 mm (1.3386 - 1.3392 in)

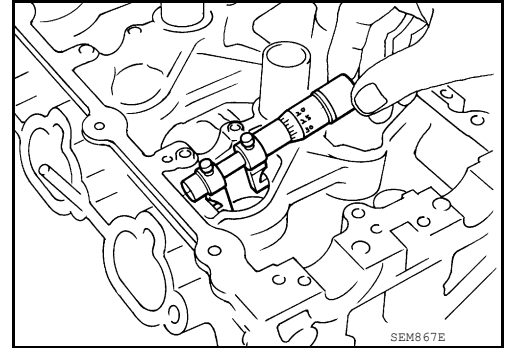

VALVE LIFTER CLEARANCE

- (Valve lifter clearance) = (Valve lifter hole diameter) – (Valve lifter outer diameter), Refer to [EM-130. "Standard and Limit"](#).

Standard (Intake and exhaust)

: 0.013 - 0.039 mm (0.0005 - 0.0015 in)

- If the calculated value is out of the standard, referring to each standard of valve lifter outer diameter and valve lifter hole diameter, replace either or both valve lifter and cylinder head.

INSTALLATION

1. Install timing chain tensioners (secondary) on both sides of cylinder head.
 - Install timing chain tensioner with its stopper pin attached.
 - Install timing chain tensioner with sliding part facing downward on right-side cylinder head, and with sliding part facing upward on left-side cylinder head.
 - Install new O-rings as shown.

CAUTION:

Do not reuse O-rings.

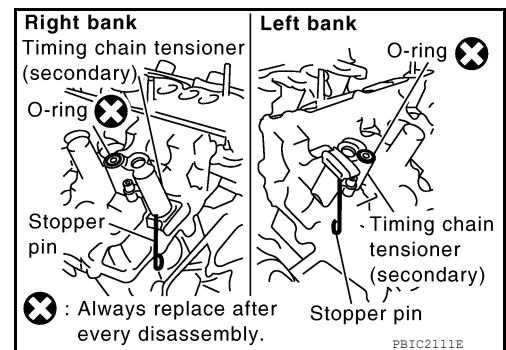

2. Install valve lifters.
 - Install it in the original position.
3. Install camshafts.

CAMSHAFT

[VQ40DE]

< REMOVAL AND INSTALLATION >

- Install camshaft with dowel pin attached to its front end face on the exhaust side.

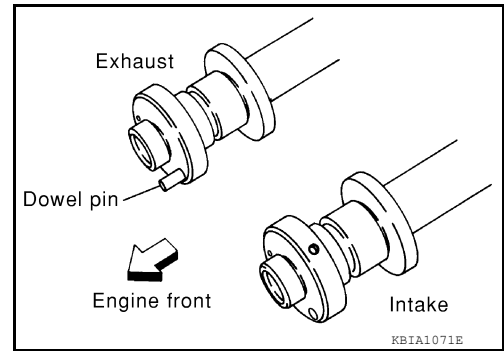

- Follow your identification marks made during removal, or follow the identification marks that are present on new camshafts for proper placement and direction.

Bank	INT/EXH	Dowel pin	Paint marks		Identification mark
			M1	M2	
RH	INT	No	Green	No	RE
	EXH	Yes	No	White	RE
LH	INT	No	Green	No	LH
	EXH	Yes	No	White	LH

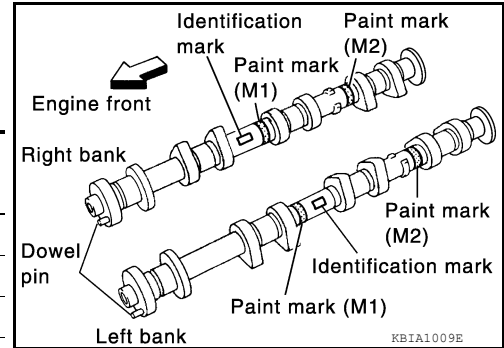

- Install camshaft so that dowel pin hole and dowel pin on front end face are positioned as shown. (No. 1 cylinder TDC on its compression stroke)

NOTE:

- Large and small pin holes are located on front end face of camshaft (INT), at intervals of 180°. Face small dia. side pin hole upward (in cylinder head upper face direction).
- Though camshaft does not stop at the portion as shown, for the placement of cam nose, it is generally accepted camshaft is placed for the same direction as shown.

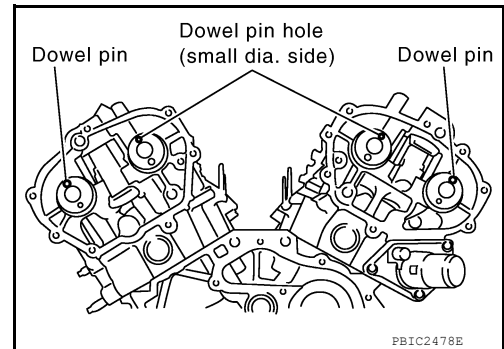

A
EM
C
D
E
F
G
H
I
J
K
L
M
N
O
P

CAMSHAFT

[VQ40DE]

< REMOVAL AND INSTALLATION >

4. Install camshaft brackets.

- Remove foreign material completely from camshaft bracket backside and from cylinder head installation face.
- Install camshaft bracket in original position and direction as shown.

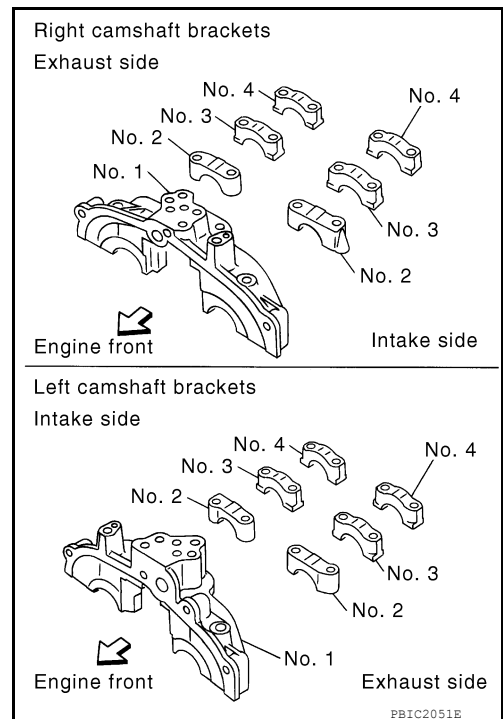

- Install camshaft brackets (No. 2 to 4) aligning the stamp marks as shown.

NOTE:

There are no identification marks indicating left and right for camshaft bracket (No. 1).

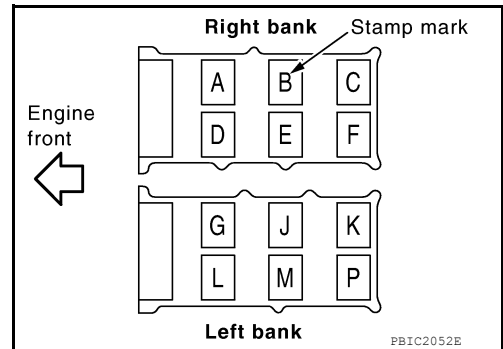

- Apply liquid gasket to mating surface of camshaft bracket (No. 1) as shown on right and left banks.

Use **Genuine RTV Silicone Sealant or equivalent**. Refer to [GI-21, "Recommended Chemical Products and Sealants"](#).

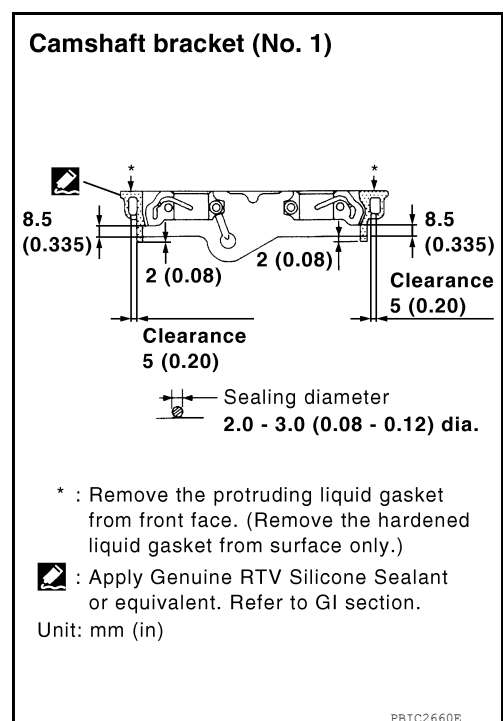

CAMSHAFT

< REMOVAL AND INSTALLATION >

[VQ40DE]

5. Tighten camshaft bracket bolts in the following steps, in numerical order as shown.

Camshaft bracket bolts

Step 1 (bolts 7 - 10) : 1.96 N·m (0.2 kg-m, 17 in-lb)

Step 2 (bolts 1 - 6) : 1.96 N·m (0.2 kg-m, 17 in-lb)

Step 3 (bolts 1 - 10) : 5.88 N·m (0.6 kg-m, 52 in-lb)

Step 4 (bolts 1 - 10) : 10.4 N·m (1.1 kg-m, 92 in-lb)

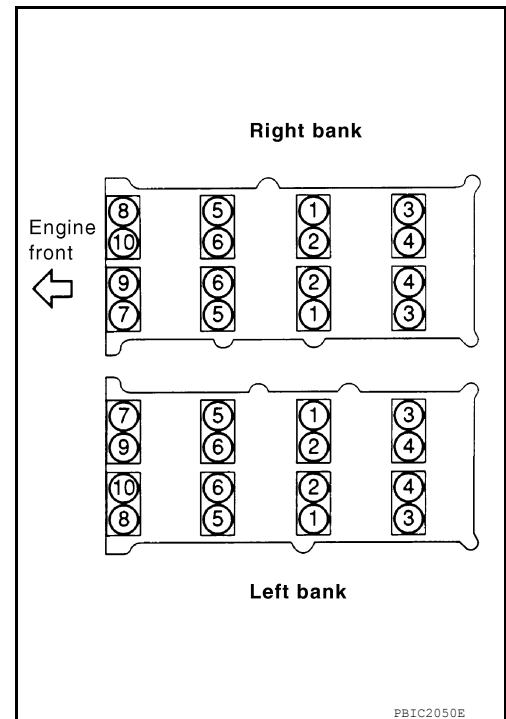

6. Measure the difference in levels between front end faces of camshaft bracket (No. 1) and cylinder head.

Standard : -0.14 to 0.14 mm (-0.0055 to 0.0055 in)

- Measure two positions (both intake and exhaust side) for a single bank.
- If the measured value is out of the standard, re-install camshaft bracket (No. 1).

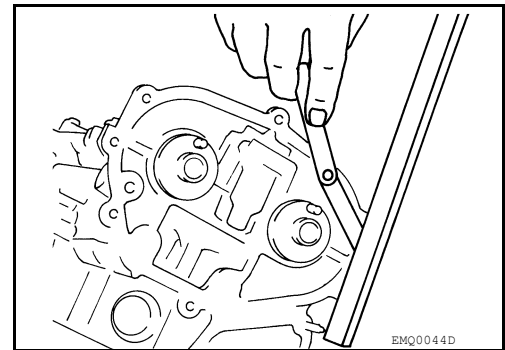

7. Check and adjust the valve clearance. Refer to [EM-130. "Standard and Limit"](#).
8. Installation of the remaining components is in the reverse order of removal.

INSPECTION AFTER INSTALLATION

Inspection of Camshaft Sprocket (INT) Oil Groove

WARNING:

- Check when engine is cold so as to prevent burns from any splashing engine oil.

CAUTION:

- Perform this inspection only when DTC P0011 or P0021 are detected in self-diagnostic results of CONSULT and it is directed according to inspection procedure of EC section. Refer to [EC-178. "DTC Confirmation Procedure"](#).

1. Check the engine oil level. Refer to [LU-7. "Inspection"](#).
2. Perform the following procedure so as to prevent the engine from being unintentionally started while checking.
 - a. Release fuel pressure. Refer to [EC-502. "Fuel Pressure Check"](#).
 - b. Disconnect the harness connectors from ignition coil and injector.
3. Remove intake valve timing control solenoid valve. Refer to [EM-51. "Removal and Installation"](#).

CAMSHAFT

[VQ40DE]

< REMOVAL AND INSTALLATION >

4. Crank the engine, and then make sure that engine oil comes out from camshaft bracket (No. 1) oil hole. End cranking after checking.

WARNING:

- Be careful not to touch rotating parts (drive belts, idler pulley, and crankshaft pulley, etc.).

CAUTION:

- Engine oil may squirt from intake valve timing control solenoid valve installation hole during cranking. Use a shop cloth to prevent the engine components and the vehicle.
- Do not allow engine oil to get on rubber components such as drive belt or engine mount insulators. Immediately wipe off any splashed engine oil.

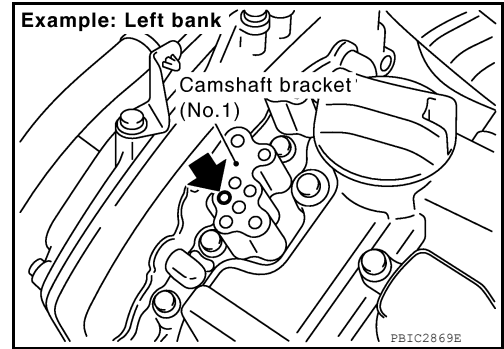

- Clean oil groove between oil strainer and intake valve timing control solenoid valve if engine oil does not come out from camshaft bracket (No. 1) oil hole. Refer to [LU-6, "Lubrication Circuit"](#), [LU-6, "System Chart"](#).
5. Remove components between intake valve timing control solenoid valve and camshaft sprocket (INT), and then check each oil groove for clogging.
 - Clean oil groove if necessary. Refer to [LU-6, "Lubrication Circuit"](#), [LU-6, "System Chart"](#).
 6. After inspection, installation of the remaining components is in the reverse order of removal.

INSPECTION AFTER INSTALLATION

- Before starting engine, check oil/fluid levels including engine coolant and engine oil. If less than required quantity, fill to the specified level. Refer to [MA-12, "Fluids and Lubricants"](#).
- Use procedure below to check for fuel leakage.
- Turn ignition switch ON (with engine stopped). With fuel pressure applied to fuel piping, check for fuel leakage at connection points.
- Start engine. With engine speed increased, check again for fuel leakage at connection points.
- Run engine to check for unusual noise and vibration.

NOTE:

If hydraulic pressure inside timing chain tensioner drops after removal and installation, slack in the guide may generate a pounding noise during and just after engine start. However, this is normal. Noise will stop after hydraulic pressure rises.

- Warm up engine thoroughly to make sure there is no leakage of fuel, exhaust gas, or any oils/fluids including engine oil and engine coolant.
- Bleed air from passages in lines and hoses, such as in cooling system.
- After cooling down engine, again check oil/fluid levels including engine oil and engine coolant. Refill to specified level, if necessary.
- Summary of the inspection items:

Item		Before starting engine	Engine running	After engine stopped
Engine coolant		Level	Leakage	Level
Engine oil		Level	Leakage	Level
Transmission/transaxle fluid	A/T and CVT Models	Leakage	Level/Leakage	Leakage
	M/T Models	Level/Leakage	Leakage	Level/Leakage
Other oils and fluids*		Level	Leakage	Level
Fuel		Leakage	Leakage	Leakage
Exhaust gas		—	Leakage	—

*Power steering fluid, brake fluid, etc.

OIL SEAL

Removal and Installation of Valve Oil Seal

INFOID:000000011069721

REMOVAL

1. Turn crankshaft until the cylinder requiring new oil seals is at TDC. This will prevent valve from dropping into cylinder.
2. Remove camshaft relating to valve oil seal to be removed. Refer to [EM-76. "Removal and Installation"](#).
3. Remove valve lifters. Refer to [EM-76. "Removal and Installation"](#).
4. Remove valve collet, valve spring retainer and valve spring using Tool.

CAUTION:

When working, take care not to damage valve lifter holes.

- Tool numbers** : KV10116200 (J-26336-B)
 : KV10115900 (J-26336-20)
 : KV10109220 (—)

- Compress valve spring using Tool attachment, adapter. Remove valve collet with magnet hand.

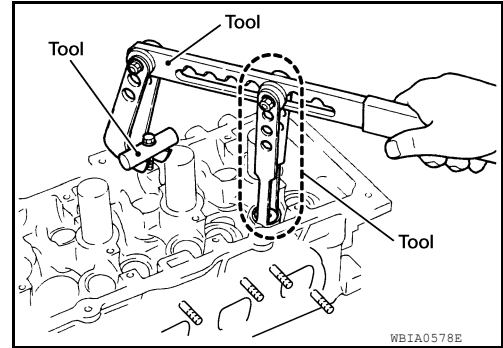

5. Remove valve oil seal using Tool.

- Tool number** : KV10107902 (J-38959)

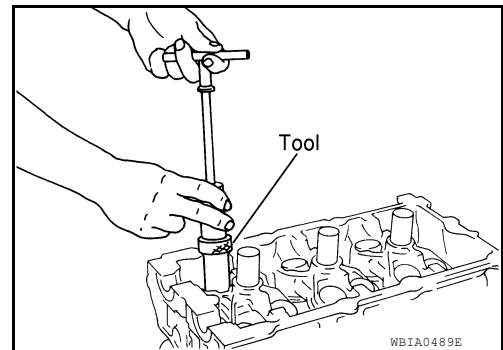

INSTALLATION

1. Apply new engine oil to new valve oil seal joint surface and seal lip.
2. Press in valve oil seal to specified height (H) using Tool.

- Tool number** : — (J-39386)

NOTE:

Dimension (H): height measured before valve spring seat installation.

- Intake and exhaust** : 14.3 - 14.9 mm (0.563 - 0.587 in)

3. Installation of the remaining components is in the reverse order of removal.

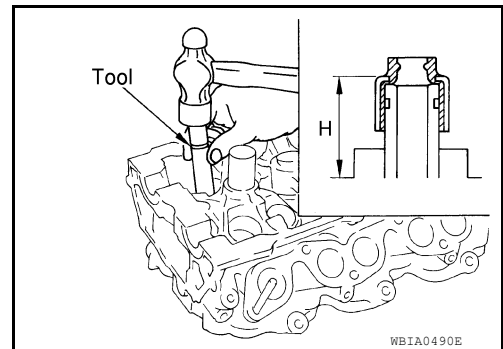

Removal and Installation of Front Oil Seal

INFOID:000000011069722

REMOVAL

1. Remove engine under cover. Refer to [EXT-15. "Removal and Installation"](#).
2. Remove drive belt. Refer to [EM-13. "Removal and Installation"](#).
3. Remove engine cooling fan assembly. Refer to [CO-18. "Removal and Installation \(Crankshaft driven type\)"](#).
4. Remove crankshaft pulley. Refer to [EM-51. "Removal and Installation"](#).

A
EM
C
D
E
F
G
H
I
J
K
L
M
N
O
P

OIL SEAL

< REMOVAL AND INSTALLATION >

[VQ40DE]

5. Remove front oil seal using suitable tool.

CAUTION:

Be careful not to damage front timing chain case and crankshaft.

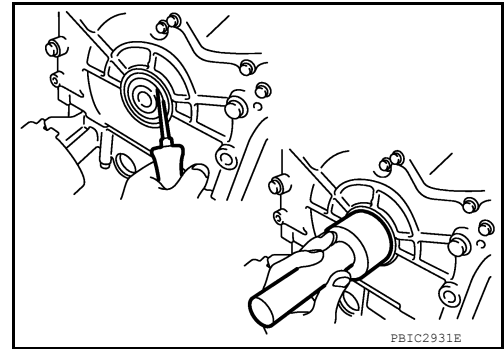

INSTALLATION

1. Apply new engine oil to both oil seal lip and dust seal lip of new front oil seal.
2. Install front oil seal.
 - Install front oil seal so that each seal lip is oriented as shown.

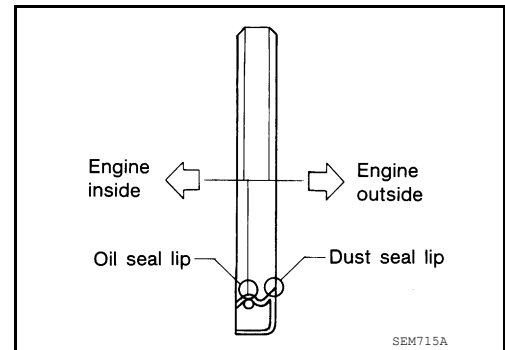

- Press-fit until the height of front oil seal is level with the mounting surface using suitable tool.
- Suitable drift: outer diameter 60 mm (2.36 in), inner diameter 50 mm (1.97 in).

CAUTION:

- **Be careful not to damage front timing chain case and crankshaft.**
- **Press-fit straight and avoid causing burrs or tilting oil seal.**

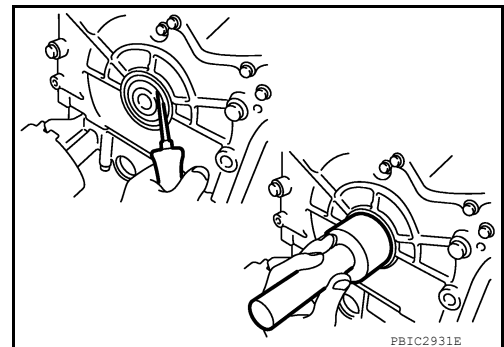

3. Installation is in the reverse order of removal after this step.

Removal and Installation of Rear Oil Seal

INFOID:000000011069723

REMOVAL

1. Remove transmission assembly. Refer to [TM-250. "Removal and Installation \(2WD\)"](#) or [TM-21. "Removal and Installation from Vehicle"](#)(2WD models), [TM-252. "Removal and Installation \(4WD\)"](#) or [TM-21. "Removal and Installation from Vehicle"](#)(4WD models).
2. Remove drive plate. Refer to [EM-102. "Exploded View"](#).

OIL SEAL

[VQ40DE]

< REMOVAL AND INSTALLATION >

3. Remove rear oil seal with a suitable tool.

CAUTION:

Be careful not to damage crankshaft and cylinder block.

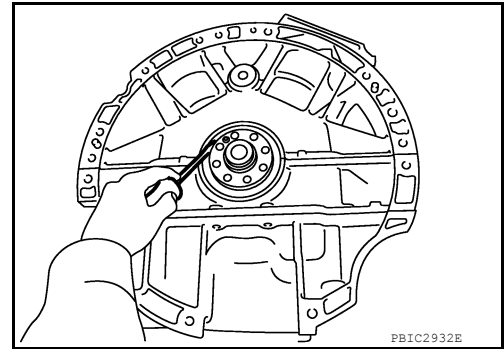

INSTALLATION

1. Apply new engine oil to new rear oil seal joint surface and seal lip.
2. Install rear oil seal so that each seal lip is oriented as shown.

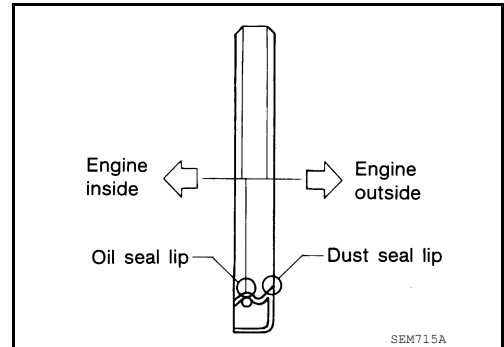

- Install new rear oil seal using Tool.

Tool number : — (J-49815)

: — (J-8092)

CAUTION:

- Be careful not to damage crankshaft and cylinder block.
- Press-fit oil seal straight to avoid causing burrs or tilting.
- Do not touch grease applied onto oil seal lip.

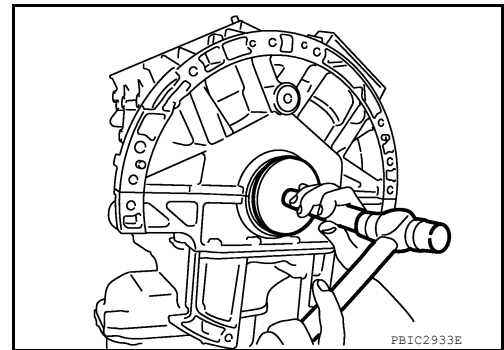

- Press in rear oil seal to the position as shown.

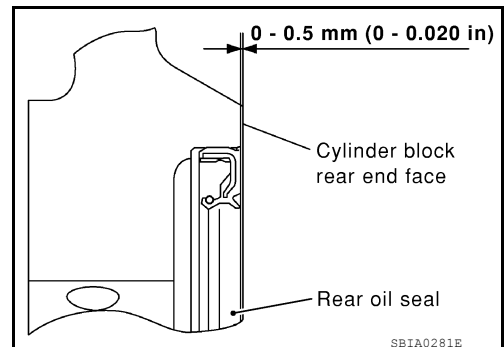

3. Installation of the remaining components is in the reverse order of removal.

CAUTION:

- When replacing an engine or transmission you must make sure the dowels are installed correctly during reassembly.
- Improper alignment caused by missing dowels may cause vibration, oil leaks or breakage of drivetrain components.

CYLINDER HEAD

< REMOVAL AND INSTALLATION >

[VQ40DE]

CYLINDER HEAD

Exploded View

INFOID:000000011069724

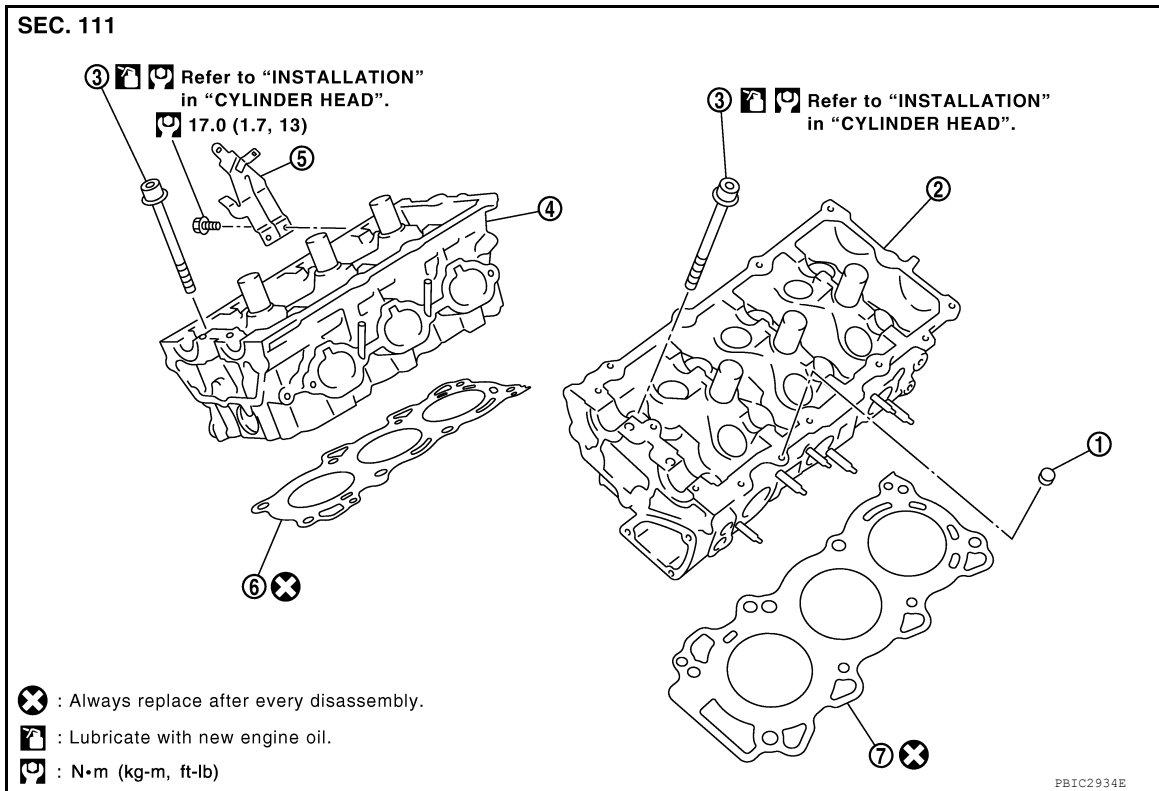

- | | | |
|-------------------------------------|------------------------------|--------------------------------------|
| 1. Rubber plug | 2. Cylinder head (left bank) | 3. Cylinder head bolt |
| 4. Cylinder head (right bank) | 5. Harness bracket | 6. Cylinder head gasket (right bank) |
| 7. Cylinder head gasket (left bank) | | |

Removal and Installation

INFOID:000000011069725

NOTE:

When removing components such as hoses, tubes/lines, etc., cap or plug openings to prevent fluid from spilling.

REMOVAL

1. Remove camshaft. Refer to [EM-76, "Removal and Installation"](#).
2. Remove intake manifold. Refer to [EM-28, "Removal and Installation"](#).
3. Remove exhaust manifold. Refer to [EM-31, "Removal and Installation \(Exhaust Manifold\)"](#).
4. Remove front final drive assembly (4WD models). Refer to [DLN-165, "Removal and Installation"](#).
5. Remove water inlet and thermostat assembly (left bank). Refer to [CO-26, "Removal and Installation"](#).
6. Remove water outlet, water pipe and heater pipe (left bank). Refer to [CO-28, "Removal and Installation"](#).

CYLINDER HEAD

< REMOVAL AND INSTALLATION >

[VQ40DE]

- Remove cylinder head bolts in reverse order as shown using suitable tool and power tool to remove cylinder heads (right and left banks).

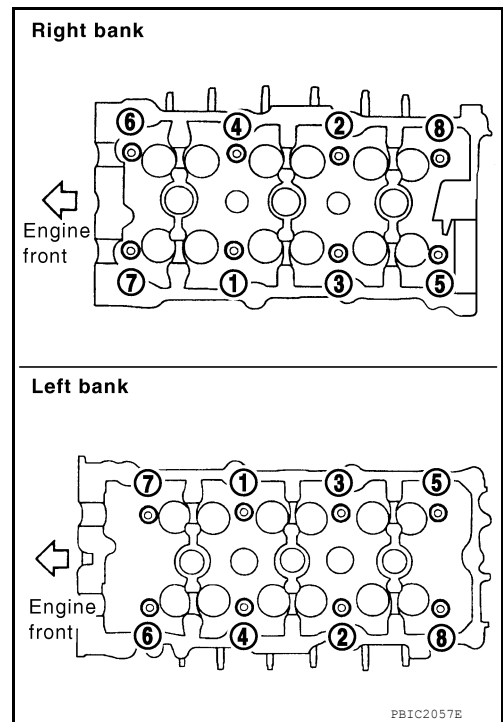

- Remove cylinder head gaskets.

INSPECTION AFTER REMOVAL

Cylinder Head Bolts Outer Diameter

- Cylinder head bolts are tightened by plastic zone tightening method. Whenever the size difference between (d1) and (d2) exceeds the limit, replace the bolt with a new one.

Limit [(d1) - (d2)] : 0.11 mm (0.0043 in)

- If reduction of outer diameter appears in a position other than (d2), use it as (d2) point.

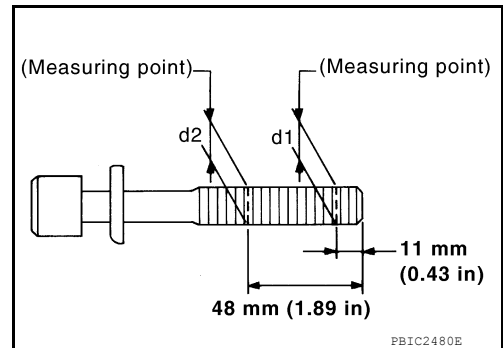

Cylinder Head Distortion

NOTE:

When performing this inspection, cylinder block distortion should be also checked. Refer to [EM-112. "Inspection After Disassembly"](#).

- Using suitable tool, wipe off oil, scale, gasket, sealant and carbon deposits from surface of cylinder head.

CAUTION:

Do not allow gasket fragments to enter engine oil or engine coolant passages.

- At each of several locations on bottom surface of cylinder head, measure the distortion in six directions.

Limit : 0.1 mm (0.004 in)

- Replace cylinder head if measured distortion exceeds the limit.

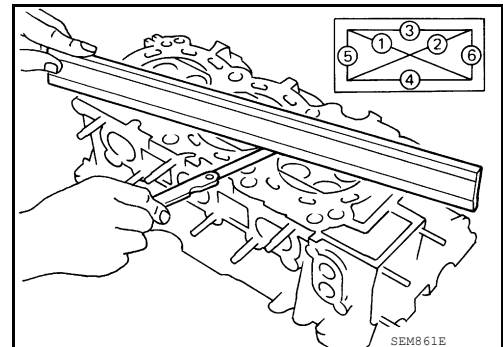

INSTALLATION

CYLINDER HEAD

[VQ40DE]

< REMOVAL AND INSTALLATION >

1. Install new cylinder head gasket.
2. Turn crankshaft until No. 1 piston is set at TDC.
 - Crankshaft key should line up with the right bank cylinder center line as shown.

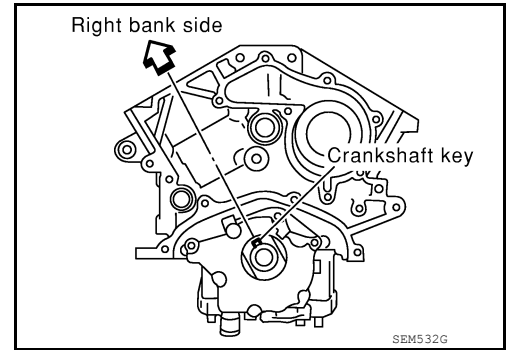

3. Install cylinder head follow the steps below to tighten cylinder head bolts in numerical order as shown.

CAUTION:

If cylinder head bolts are re-used, check their outer diameters before installation. Refer to [EM-88, "Removal and Installation"](#) (Cylinder Head Bolts Outer Diameter).

Step a : 98.1 N·m (10 kg-m, 72 ft-lb)

Step b : Loosen to 0 N·m in the reverse order of tightening.

Step c : 39.2 N·m (4.0 kg-m, 29 ft-lb)

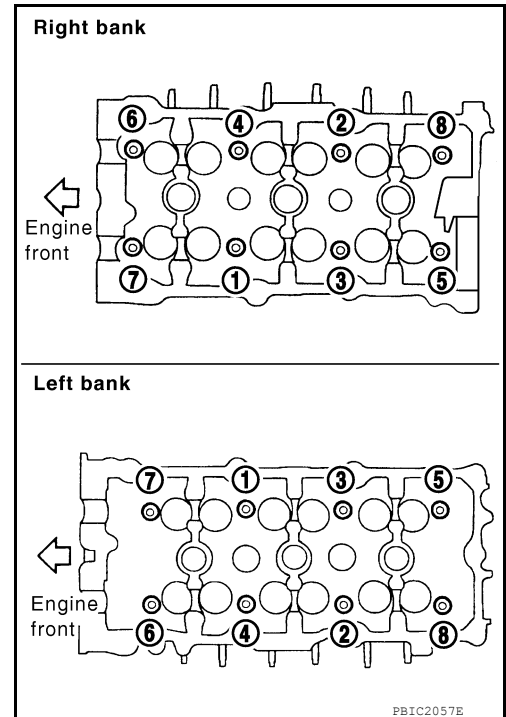

Measure the tightening angle using Tool.

Tool number : KV10112100 (BT-8653-A)

Step d : 90° clockwise

Step e : 90° clockwise

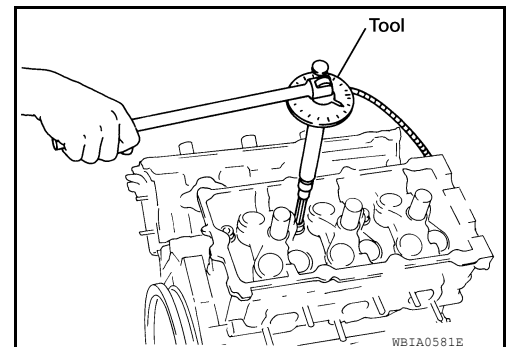

CYLINDER HEAD

< REMOVAL AND INSTALLATION >

[VQ40DE]

- After installing cylinder head, measure distance between front end faces of cylinder block and cylinder head (left and right banks).

Standard : 14.1 - 14.9 mm (0.555 - 0.587 in)

- If the measured value is out of the standard, re-install cylinder head.

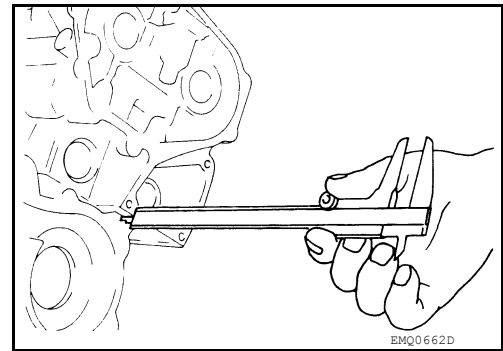

- Installation of the remaining parts is in the reverse order of removal.

INSPECTION AFTER INSTALLATION

- Before starting engine, check oil/fluid levels including engine coolant and engine oil. If less than required quantity, fill to the specified level. Refer to [MA-12, "Fluids and Lubricants"](#).
- Use procedure below to check for fuel leakage.
- Turn ignition switch ON (with engine stopped). With fuel pressure applied to fuel piping, check for fuel leakage at connection points.
- Start engine. With engine speed increased, check again for fuel leakage at connection points.
- Run engine to check for unusual noise and vibration.

NOTE:

If hydraulic pressure inside timing chain tensioner drops after removal and installation, slack in the guide may generate a pounding noise during and just after engine start. However, this is normal. Noise will stop after hydraulic pressure rises.

- Warm up engine thoroughly to make sure there is no leakage of fuel, exhaust gas, or any oils/fluids including engine oil and engine coolant.
- Bleed air from passages in lines and hoses, such as in cooling system.
- After cooling down engine, again check oil/fluid levels including engine oil and engine coolant. Refill to specified level, if necessary.
- Summary of the inspection items:

Item		Before starting engine	Engine running	After engine stopped
Engine coolant		Level	Leakage	Level
Engine oil		Level	Leakage	Level
Transmission/ transaxle fluid	A/T and CVT Models	Leakage	Level/Leakage	Leakage
	M/T Models	Level/Leakage	Leakage	Level/Leakage
Other oils and fluids*		Level	Leakage	Level
Fuel		Leakage	Leakage	Leakage
Exhaust gas		—	Leakage	—

*Power steering fluid, brake fluid, etc.

CYLINDER HEAD

< REMOVAL AND INSTALLATION >

[VQ40DE]

Exploded View

INFOID:000000011069726

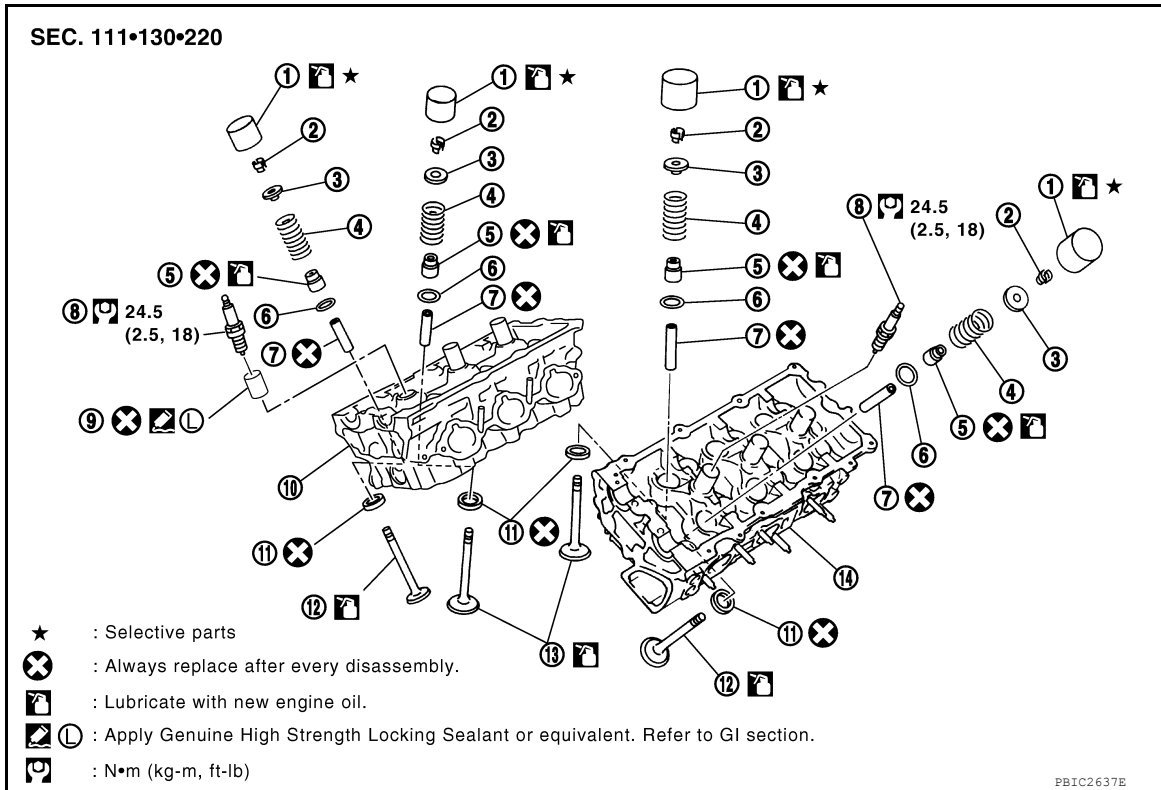

- | | | |
|--------------------------------|-------------------------------|--------------------------|
| 1. Valve lifter | 2. Valve collet | 3. Valve spring retainer |
| 4. Valve spring | 5. Valve oil seal | 6. Valve spring seat |
| 7. Valve guide | 8. Spark plug | 9. Spark plug tube |
| 10. Cylinder head (right bank) | 11. Valve seat | 12. Valve (EXH) |
| 13. Valve (INT) | 14. Cylinder head (left bank) | |

Disassembly and Assembly

INFOID:000000011069727

DISASSEMBLY

- Remove spark plug.
- Remove valve lifter.
 - Identify installation positions, and store them without mixing them up.
- Remove valve collet.
 - Compress valve spring and remove valve collet with magnet hand using Tool.

CAUTION:
 When working, take care not to damage valve lifter holes.

Tool numbers : KV10109220 (—)
 : KV10116200 (J-26336-B)
 : KV10115900 (J-26336-20)

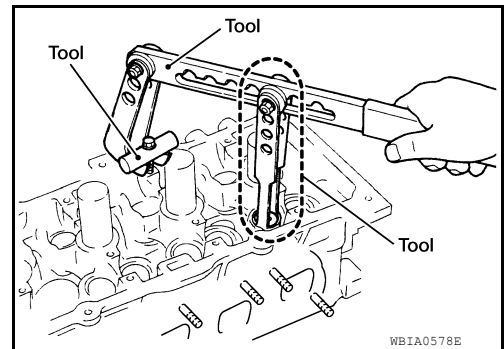

- Remove valve spring retainer, valve spring and valve spring seat.
- Push valve stem to combustion chamber side, and remove valve.
 - Identify installation positions, and store them without mixing them up.

CYLINDER HEAD

< REMOVAL AND INSTALLATION >

[VQ40DE]

6. Remove valve oil seals using Tool.

Tool number : KV10107902 (J-38959)

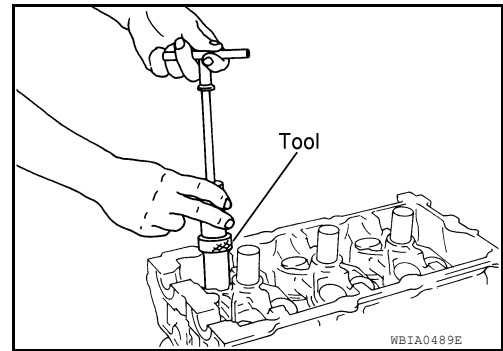

7. If valve seat must be replaced, refer to [EM-94, "Inspection After Disassembly"](#).
8. If valve guide must be replaced, refer to [EM-94, "Inspection After Disassembly"](#).
9. Remove spark plug tube, as necessary.
- Pull spark plug tube out of cylinder head using a suitable tool.
- CAUTION:**
- **Take care not to damage cylinder head.**
 - **Once removed, spark plug tube will be deformed and cannot be reused. Do not remove it unless absolutely necessary.**

ASSEMBLY

1. When valve guide is removed, install it. Refer to [EM-94, "Inspection After Disassembly"](#).
2. When valve seat is removed, install it. Refer to [EM-94, "Inspection After Disassembly"](#).
3. Install valve oil seals using Tool.

Tool number : — (J-39386)

Height (H) (Without valve spring seat installed)

Intake and exhaust : 14.3 - 14.9 mm (0.563 - 0.587 in)

4. Install valve spring seat.
5. Install valves.
- Install it in the original position.
- NOTE:**
Larger diameter valves are for intake side.

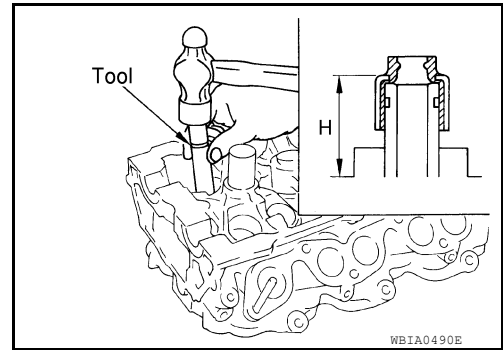

6. Install valve spring (uneven pitch type).
- Install narrow pitch end (paint mark) to cylinder head side (valve spring seat side).

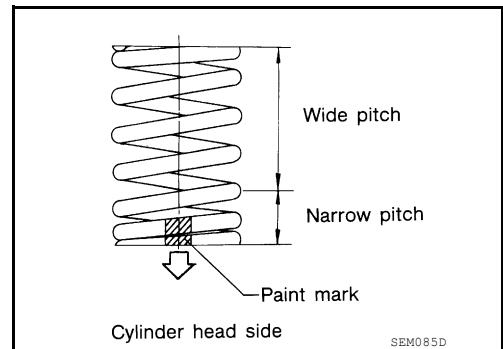

7. Install valve spring retainer.

CYLINDER HEAD

< REMOVAL AND INSTALLATION >

[VQ40DE]

8. Install valve collet.
- Compress valve spring using Tool, attachment and adapter using Tool. Install valve collet with magnet hand.

Tool numbers : KV10109220 (—)
: KV10116200 (J-26336-B)
: KV10115900 (J-26336-20)

CAUTION:

When working, take care not to damage valve lifter holes or valve stems.

- Tap valve stem edge lightly with plastic hammer after installation to check its installed condition.

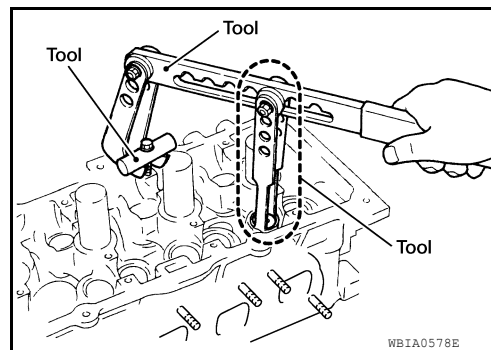

9. Install valve lifter.
- Install it in the original position.
10. Install spark plug tube.
- Press-fit spark plug tube as follows:
- a. Remove old liquid gasket adhering to cylinder head mounting hole.
- b. Apply sealant to area within approximately 12 mm (0.47 in) from edge of spark plug tube press-fit side. **Use Genuine High Strength Locking Sealant or equivalent. Refer to [GI-21, "Recommended Chemical Products and Sealants"](#).**
- c. Press-fit spark plug tube so that its height (H) is as specified using suitable drift.

Standard press-fit height (H)
: 38.1 - 39.1 mm (1.500 - 1.539 in)

CAUTION:

- When press-fitting, take care not to deform spark plug tube.
- After press-fitting, wipe off liquid gasket protruding onto cylinder-head upper face.

11. Install spark plug. Refer to [EM-16, "Removal and Installation"](#).

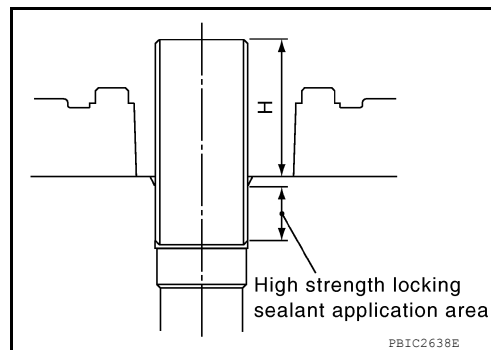

Inspection After Disassembly

INFOID:000000011069728

VALVE DIMENSIONS

- Check dimensions of each valve. Refer to [EM-130, "Standard and Limit"](#).
- If dimensions are out of the standard, replace valve and check the valve seat contact.

VALVE GUIDE CLEARANCE

Valve Stem Diameter

Measure the diameter of valve stem with micrometer.

Standard

Intake : 5.965 - 5.980 mm (0.2348 - 0.2354 in)
Exhaust : 5.955 - 5.970 mm (0.2344 - 0.2350 in)

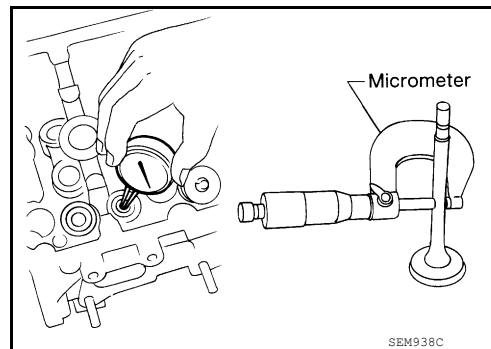

Valve Guide Inner Diameter

Measure the inner diameter of valve guide with inside micrometer.

CYLINDER HEAD

< REMOVAL AND INSTALLATION >

[VQ40DE]

Standard

Intake and Exhaust : 6.000 - 6.018 mm (0.2362 - 0.2369 in)

Valve Guide Clearance

(Valve guide clearance) = (Valve guide inner diameter) – (Valve stem diameter).

Valve guide clearance:

Standard

Intake : 0.020 - 0.053 mm (0.0008 - 0.0021 in)

Exhaust : 0.030 - 0.063 mm (0.0012 - 0.0025 in)

Limit

Intake : 0.08 mm (0.003 in)

Exhaust : 0.09 mm (0.004 in)

- If the calculated value exceeds the limit, replace valve and/or valve guide.

VALVE GUIDE REPLACEMENT

When valve guide is removed, replace with oversized [0.2 mm (0.008 in)] valve guide.

1. To remove valve guide, heat cylinder head to 110° to 130°C (230° to 266°F) by soaking in heated oil.

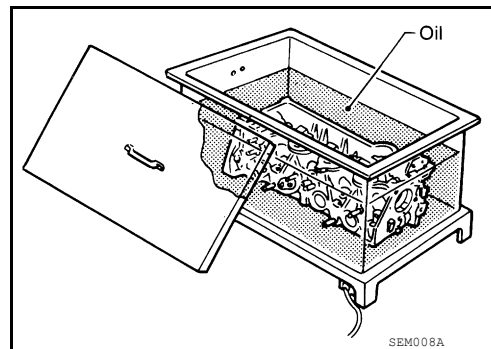

2. Drive out valve guide with a press [under a 20 kN (2 ton, 2.2 US ton, 2.0 Imp ton) pressure] or hammer and suitable tool.

WARNING:

Cylinder head contains heat. When working, wear protective equipment to avoid getting burned.

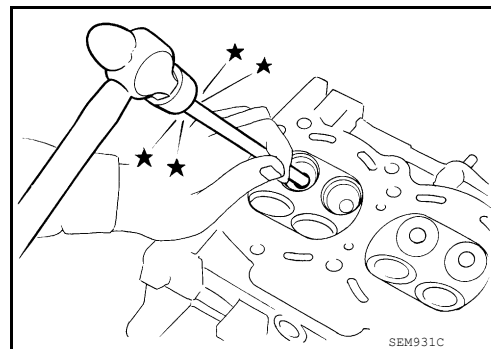

3. Ream cylinder head valve guide hole using suitable tool.

Valve guide hole diameter (for service parts):

Intake and exhaust

: 10.175 - 10.196 mm (0.4006 - 0.4014 in)

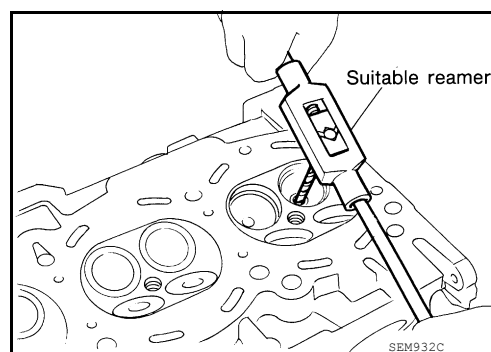

CYLINDER HEAD

[VQ40DE]

< REMOVAL AND INSTALLATION >

- Heat cylinder head to 110° to 130°C (230° to 266°F) by soaking in heated oil.

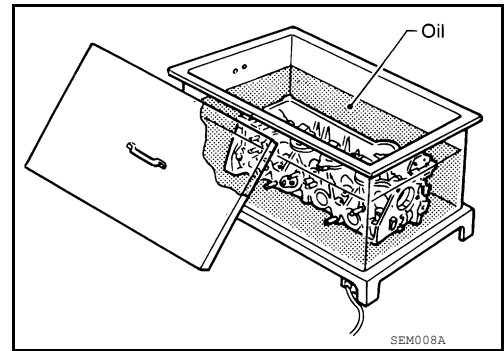

- Press valve guide from camshaft side to the dimensions as shown using suitable tool.

Projection "L"

Intake and exhaust

: 12.6 - 12.8 mm (0.496 - 0.504 in)

WARNING:

Cylinder head contains heat. When working, wear protective equipment to avoid getting burned.

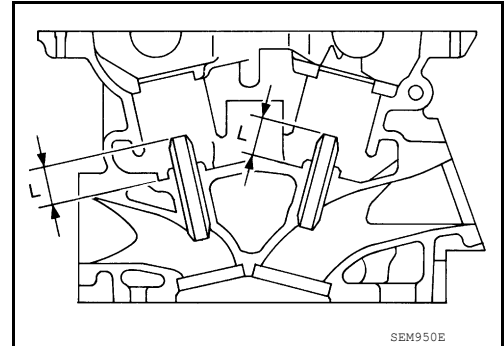

- Apply reamer finish to valve guide using suitable tool.

Standard:

Intake and exhaust

: 6.000 - 6.018 mm (0.2362 - 0.2369 in)

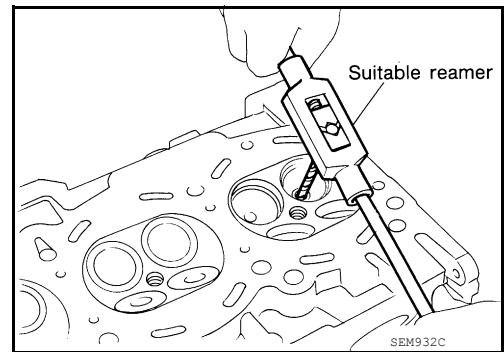

VALVE SEAT CONTACT

- After confirming that the dimensions of valve guides and valves are within the specifications, perform this procedure.
- Apply prussian blue (or white lead) onto contacting surface of valve seat to check the condition of the valve contact on the surface.
- Check if the contact area band is continuous all around the circumference.
- If not, grind to adjust valve fitting and check again. If the contacting surface still has "NG" conditions even after the re-check, replace valve seat.

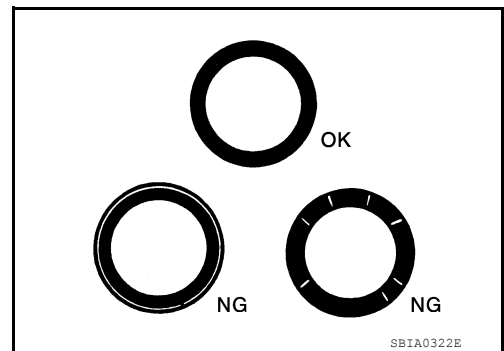

VALVE SEAT REPLACEMENT

When valve seat is removed, replace with oversized [0.5 mm (0.020 in)] valve seat.

- Bore out old seat until it collapses. Boring should not continue beyond the bottom face of the seat recess in cylinder head. Set the machine depth stop to ensure this. Refer to [EM-130, "Standard and Limit"](#).

CAUTION:

Do not scratch cylinder head by excessive boring.

CYLINDER HEAD

< REMOVAL AND INSTALLATION >

[VQ40DE]

2. Ream cylinder head recess diameter for service valve seat.

Oversize [0.5 mm (0.020 in)]

Intake : 38.500 - 38.516 mm (1.5157 - 1.5164 in)

Exhaust : 32.700 - 32.716 mm (1.2874 - 1.2880 in)

- Be sure to ream in circles concentric to valve guide center. This will enable valve to fit correctly.

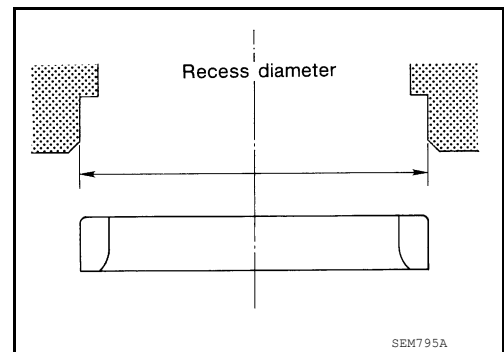

3. Heat cylinder head to 110° to 130°C (230° to 266°F) by soaking in heated oil.

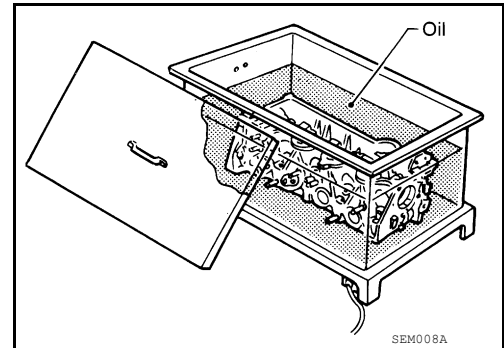

4. Provide valve seats cooled well with dry ice. Force fit valve seat into cylinder head.

WARNING:

- **Cylinder head contains heat. When working, wear protective equipment to avoid getting burned.**

CAUTION:

- **Avoid directly touching cold valve seats.**

5. Finish seat to the specified dimensions using suitable tool. Refer to [EM-130, "Standard and Limit"](#).

CAUTION:

- **When using valve seat cutter, firmly grip cutter handle with both hands. Then, press on the contacting surface all around the circumference to cut in a single drive. Improper pressure on cutter or cutting many different times may result in staged valve seat.**

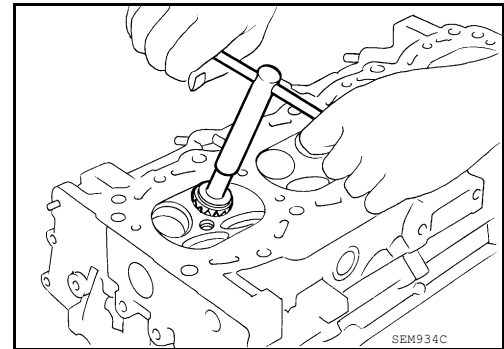

6. Using compound, grind to adjust valve fitting.

7. Check again for normal contact.

VALVE SPRING SQUARENESS

- Set try square along the side of valve spring and rotate spring. Measure the maximum clearance between the top face of spring and try square.

Limit : 2.1 mm (0.083 in)

- If it exceeds the limit, replace valve spring.

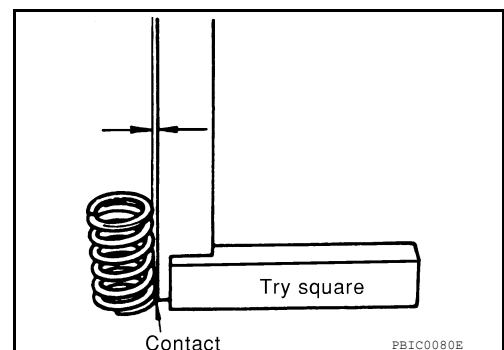

VALVE SPRING DIMENSIONS AND VALVE SPRING PRESSURE LOAD

CYLINDER HEAD

< REMOVAL AND INSTALLATION >

[VQ40DE]

- Check valve spring pressure at the specified spring height.

Standard:

Intake and exhaust

Free height

: 47.07 mm (1.8531 in)

Installation height

: 37.00 mm (1.4567 in)

Installation load

: 166 - 188 N (16.9 - 19.2 kg, 37 - 42 lb)

Height during valve open

: 27.20 mm (1.0709 in)

Load with valve open

: 373 - 421 N (38.0 - 42.9 kg, 84 - 95 lb)

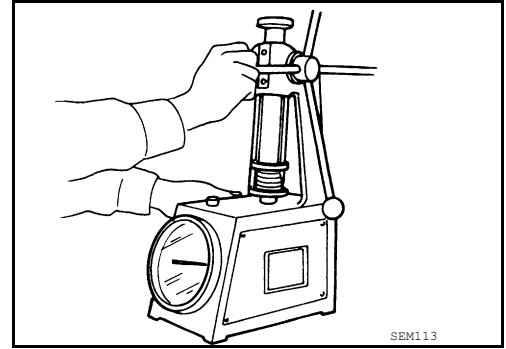

- If the installation load or load with valve open is out of the standard, replace valve spring.

UNIT REMOVAL AND INSTALLATION

ENGINE ASSEMBLY

Exploded View

INFOID:000000011069729

A

EM

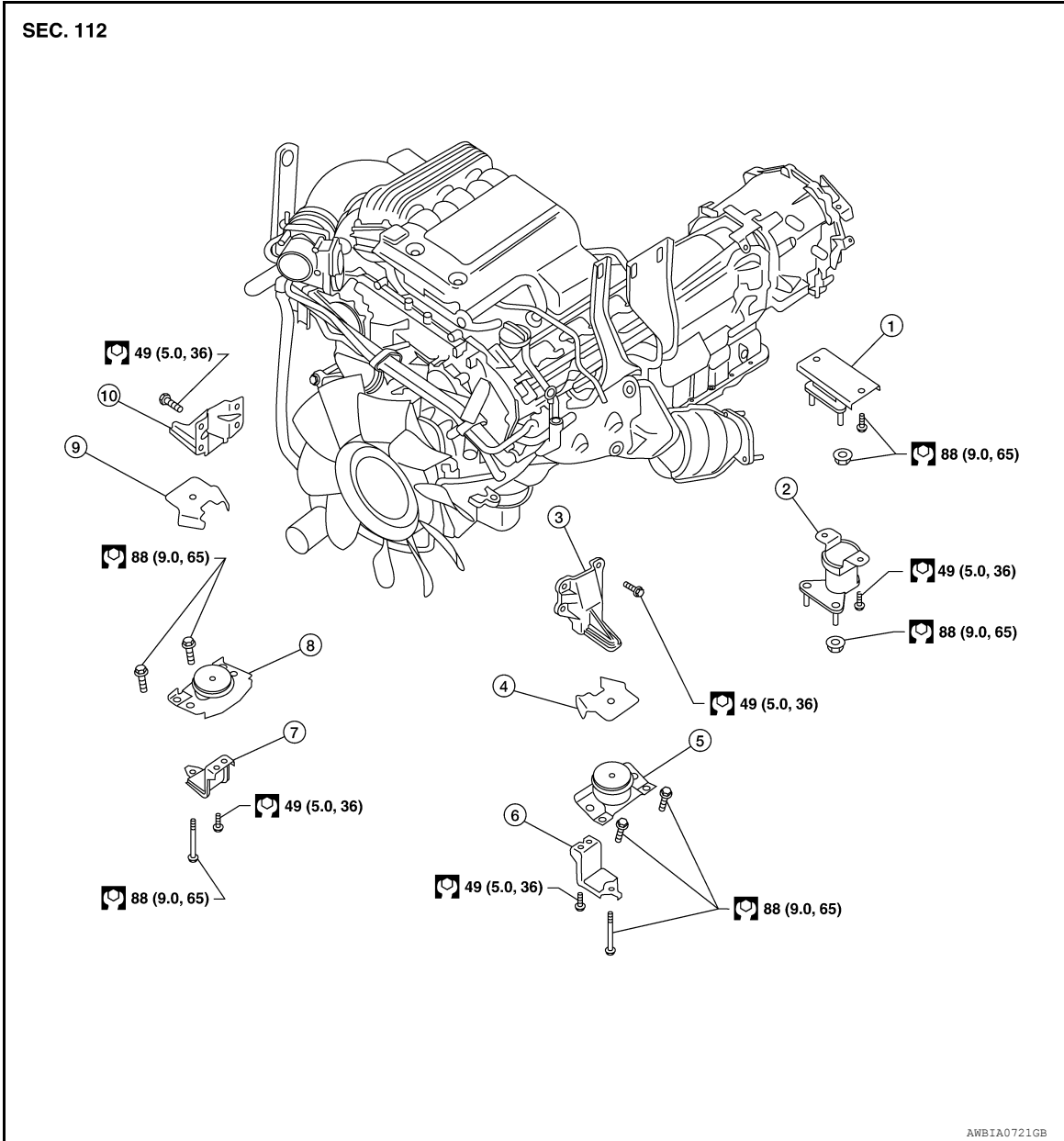

C

D

E

F

G

H

I

J

K

L

M

N

O

P

- | | | |
|----------------------------------------|---------------------------------------|---------------------------------------|
| 1. Rear engine mounting insulator 4WD | 2. Rear engine mounting insulator 2WD | 3. LH engine mounting bracket (upper) |
| 4. LH heat shield plate | 5. LH engine mounting insulator | 6. LH engine mounting bracket (lower) |
| 7. RH engine mounting bracket (lower) | 8. RH engine mounting insulator | 9. RH heat shield plate |
| 10. RH engine mounting bracket (upper) | | |

Removal and Installation

INFOID:000000011069730

WARNING:

- Situate vehicle on a flat and solid surface.
- Place chocks at front and back of rear wheels.
- For engines not equipped with engine slingers, attach proper slingers and bolts described in PARTS CATALOG.

ENGINE ASSEMBLY

< UNIT REMOVAL AND INSTALLATION >

[VQ40DE]

- When lifting vehicle ensure that the front and rear of the vehicle are balanced.

CAUTION:

- Always be careful to work safely, avoid forceful or uninstructed operations.
- Do not start working until exhaust system and engine coolant are cooled sufficiently.
- If items or work required are not covered by the engine section, follow the procedures in the applicable sections.
- Always use the support point specified for lifting.
- Use either 2-point lift type or separate type lift. If board-on type is used for unavoidable reasons, support at the rear axle jacking point with transmission jack or similar tool before starting work, in preparation for the backward shift of center of gravity.
- For supporting points for lifting and jacking point at rear axle. Refer to [GI-32, "Garage Jack and Safety Stand"](#).

NOTE:

When removing components such as hoses, tubes/lines, etc., cap or plug openings to prevent fluid from spilling.

REMOVAL

Preparation

1. Remove engine under cover (If equipped). Refer to [EXT-15, "Removal and Installation"](#).
2. Drain engine coolant. Refer to [CO-11, "Changing Engine Coolant"](#).
3. Release fuel pressure. Refer to [EC-502, "Fuel Pressure Check"](#).
4. Remove the engine hood. Refer to [DLK-104, "Removal and Installation of Hood Assembly"](#).
5. Disconnect the battery negative terminal. Refer to [PG-77, "Removal and Installation"](#).
6. Remove the air duct and resonator assembly and air cleaner case assembly. Refer to [EM-24, "Removal and Installation"](#).
7. Disconnect brake booster vacuum hose between vehicle and engine and set it aside.
8. Remove the radiator assembly and hoses. Refer to [CO-15, "Removal and Installation"](#).
9. Remove the drive belt. Refer to [EM-13, "Removal and Installation"](#).
10. Remove the engine cooling fan (crankshaft driven type) and shroud. Refer to [CO-18, "Removal and Installation \(Crankshaft driven type\)"](#).
11. Disconnect the engine room harness from the engine side and set it aside.
12. Disconnect the engine harness grounds.
13. Reposition the power steering reservoir tank aside in the engine compartment.
14. Disconnect power steering oil pump from engine. Move it from its location and secure with a rope. Refer to [ST-17, "Removal and Installation"](#).
15. Remove the A/C compressor bolts and reposition the A/C compressor without disconnecting the A/C hoses. Refer to [HA-27, "Removal and Installation of Compressor"](#).
16. Disconnect EVAP line.
17. Disconnect the fuel hose at the engine side connection. Refer to [EM-45, "Removal and Installation"](#).
18. Disconnect the heater hoses at cowl, and install plugs to avoid leakage of engine coolant.
19. Remove the A/T oil level indicator and indicator tube (A/T models).
20. Remove front final drive assembly (4WD models). Refer to [DLN-165, "Removal and Installation"](#).
21. Remove three way catalyst. Refer to [EM-30, "Removal and Installation \(Three Way Catalyst\)"](#).
22. Install engine slingers into left bank and right bank.

Engine slinger torque: 28.0 N·m (2.9 kg-m, 21 ft-lb)



ENGINE ASSEMBLY

< UNIT REMOVAL AND INSTALLATION >

[VQ40DE]

23. Remove front frame crossmember.
24. Remove transmission. Refer to [TM-21, "Removal and Installation from Vehicle"](#) (4WD M/T models), [TM-250, "Removal and Installation \(2WD\)"](#) (2WD A/T models), [TM-252, "Removal and Installation \(4WD\)"](#) (4WD A/T models).
25. Remove engine mounting insulator bracket (upper) with power tool.
26. Lift with hoist and secure the engine in position.
27. Remove engine mount bracket bolts.
28. Remove engine assembly from vehicle, avoiding interference with vehicle body.

CAUTION:

Repeatedly check to ensure all harnesses are disconnected before and during engine lifting.

INSTALLATION

Installation is in the reverse order of removal.

CAUTION:

- **When replacing an engine or transmission you must make sure the dowels are installed correctly during reassembly.**
- **Improper alignment caused by missing dowels may cause vibration, oil leaks or breakage of drivetrain components.**

INSPECTION AFTER INSTALLATION

- Before starting engine, check oil/fluid levels including engine coolant and engine oil. If less than required quantity, fill to the specified level. Refer to [MA-12, "Fluids and Lubricants"](#).
- Use procedure below to check for fuel leakage.
- Turn ignition switch ON (with engine stopped). With fuel pressure applied to fuel piping, check for fuel leakage at connection points.
- Start engine. With engine speed increased, check again for fuel leakage at connection points.
- Run engine to check for unusual noise and vibration.

NOTE:

If hydraulic pressure inside timing chain tensioner drops after removal and installation, slack in the guide may generate a pounding noise during and just after engine start. However, this is normal. Noise will stop after hydraulic pressure rises.

- Warm up engine thoroughly to make sure there is no leakage of fuel, exhaust gas, or any oils/fluids including engine oil and engine coolant.
- Bleed air from passages in lines and hoses, such as in cooling system.
- After cooling down engine, again check oil/fluid levels including engine oil and engine coolant. Refill to specified level, if necessary.
- Summary of the inspection items:

Item		Before starting engine	Engine running	After engine stopped
Engine coolant		Level	Leakage	Level
Engine oil		Level	Leakage	Level
Transmission/ transaxle fluid	A/T and CVT Models	Leakage	Level/Leakage	Leakage
	M/T Models	Level/Leakage	Leakage	Level/Leakage
Other oils and fluids*		Level	Leakage	Level
Fuel		Leakage	Leakage	Leakage
Exhaust gas		—	Leakage	—

*Power steering fluid, brake fluid, etc.

ENGINE UNIT

< UNIT DISASSEMBLY AND ASSEMBLY >

[VQ40DE]

UNIT DISASSEMBLY AND ASSEMBLY

ENGINE UNIT

Exploded View

INFOID:000000011069731

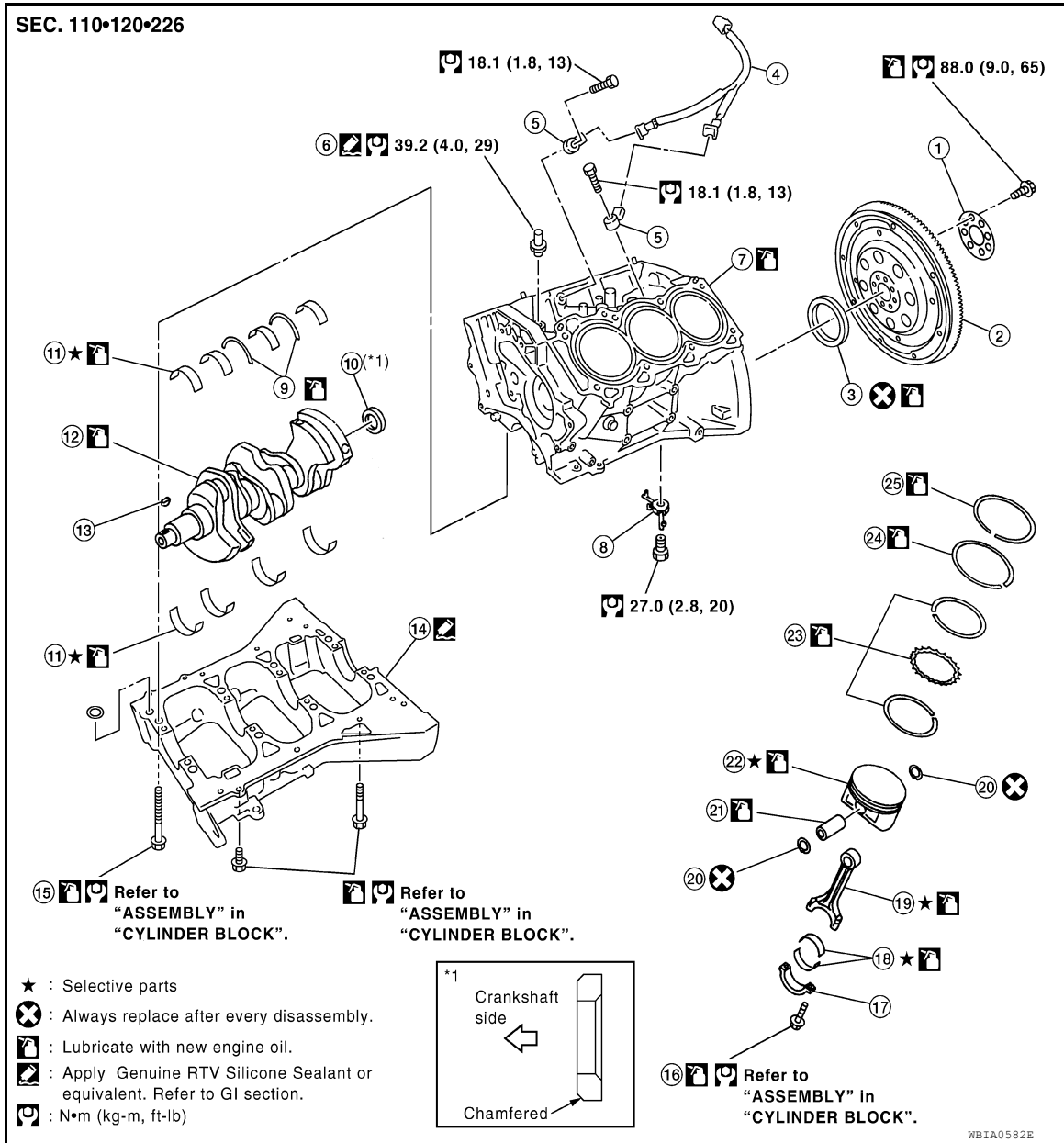

- | | | |
|----------------------------------|----------------------------------------------------|-------------------------------|
| 1. Reinforcement plate | 2. Drive plate (A/T models), Flywheel (M/T models) | 3. Rear oil seal |
| 4. Sub harness | 5. Knock sensor | 6. Water connector |
| 7. Cylinder block | 8. Oil jet | 9. Thrust bearing |
| 10. Pilot converter (A/T models) | 11. Main bearing | 12. Crankshaft |
| 13. Crankshaft key | 14. Lower cylinder block | 15. Lower cylinder block bolt |
| 16. Connecting rod bolt | 17. Connecting rod bearing cap | 18. Connecting rod bearing |
| 19. Connecting rod | 20. Snap ring | 21. Piston pin |
| 22. Piston | 23. Oil ring | 24. Second ring |
| 25. Top ring | | |

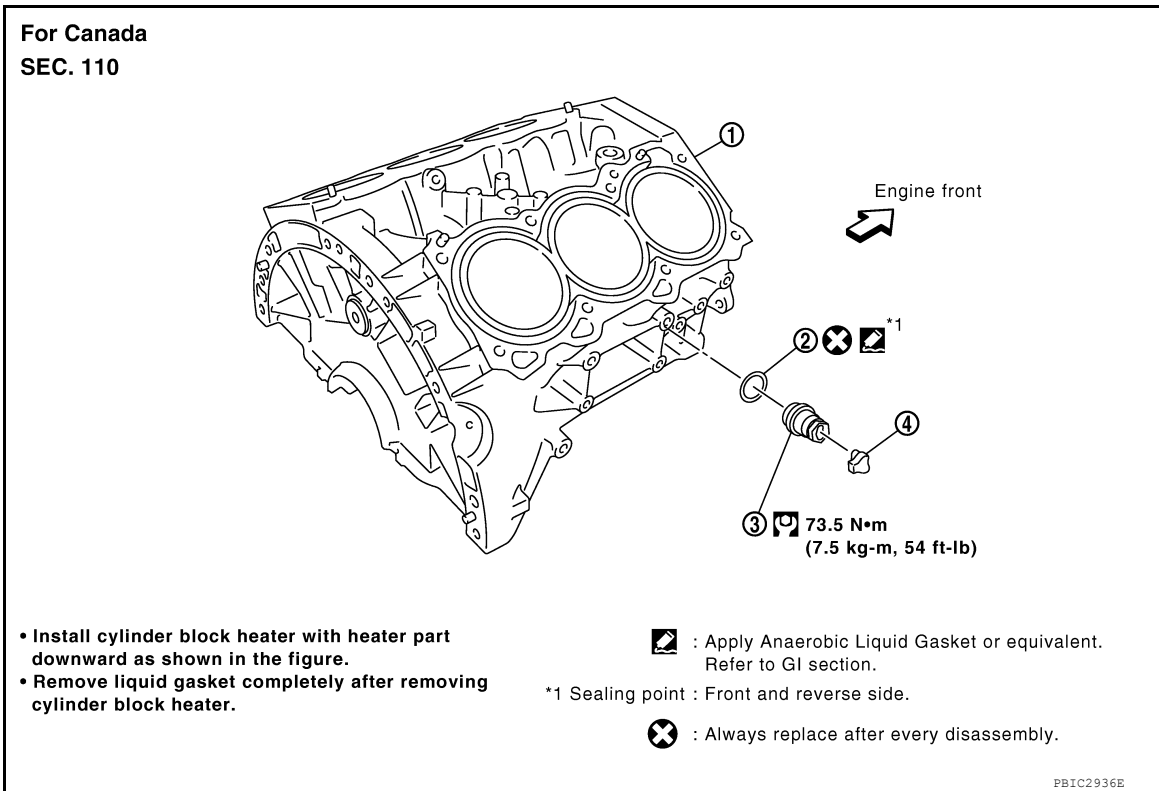

- | | | |
|----------------------------|-----------|--------------------------|
| 1. Cylinder block | 2. Gasket | 3. Cylinder block heater |
| 4. Connector protector cap | | |

Disassembly and Assembly

INFOID:000000011069732

DISASSEMBLY

NOTE:

The following procedures explain how to disassemble the engine with the engine stand fastened to the bell housing. Some steps may be different if using a different type of engine stand.

1. Remove engine assembly from vehicle. Refer to [EM-99. "Removal and Installation"](#).
2. Remove both exhaust manifolds. Refer to [EM-31. "Removal and Installation \(Exhaust Manifold\)"](#).
3. Remove the generator. Refer to [CHG-27. "Removal and Installation"](#).
4. Remove the parts that may restrict installation of engine to engine stand.
 - a. Remove clutch cover and clutch disc (M/T models). Refer to [CL-15. "Removal and Installation"](#).
 - b. Remove flywheel (M/T models) or drive plate (A/T models).
 - Holding crankshaft pulley bolts, lock crankshaft to remove flywheel or drive plate bolts.
 - Loosen bolts diagonally.

CAUTION:

- Be careful not to damage or scratch drive plate (A/T models) and contact surface for clutch disc of flywheel (M/T models). Especially avoid deforming and damaging of signal plate teeth (circumference position).
- Do not disassemble drive plate.
- Place the drive plate with signal plate surface facing other than downward.
- Keep magnetic materials away from signal plate.

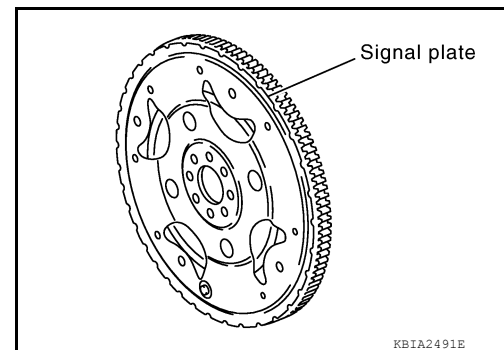

ENGINE UNIT

< UNIT DISASSEMBLY AND ASSEMBLY >

[VQ40DE]

5. Remove pilot converter (A/T models) using Tool as necessary.

Tool number : ST16610001 (J-23907)

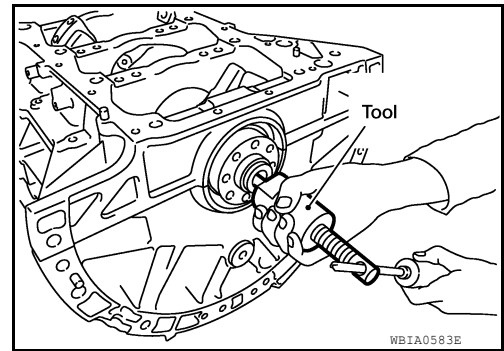

6. Lift engine, and mount to engine stand.

- Any widely used commercially available engine stand can be used.

CAUTION:

- Before removing the hanging chains, make sure engine stand is stable and there is no risk of overturning.
- Use engine stand that has a load capacity large enough to support the engine's weight [approximately 220 kg (441 lb) or more].
- If the load capacity of the stand is not adequate, remove the following parts to reduce the potential risk of overturning the stand.
- Remove fuel tube and fuel injector assembly. Refer to [EM-45, "Removal and Installation"](#).
- Remove intake manifold. Refer to [EM-28, "Removal and Installation"](#).
- Remove rocker cover. Refer to [EM-41, "Removal and Installation"](#).
- Other removable brackets.

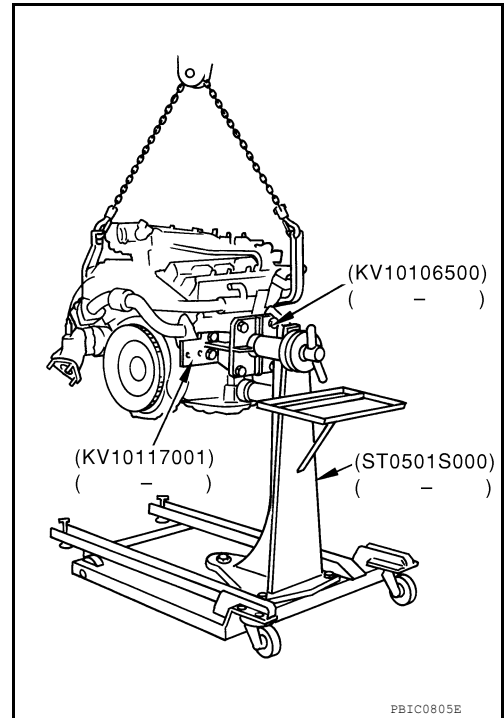

7. Drain engine coolant by removing the cylinder block drain plugs (A), (B), (C) and (D) from cylinder block as shown.

NOTE:

For Canada, (D) is not plug but block heater.

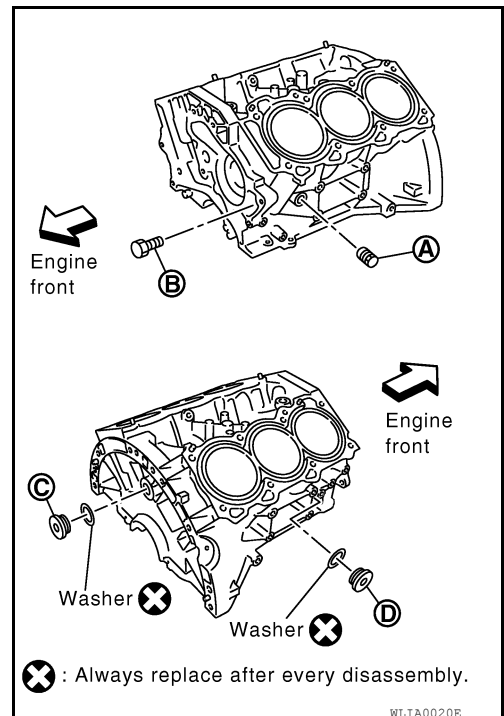

ENGINE UNIT

< UNIT DISASSEMBLY AND ASSEMBLY >

[VQ40DE]

8. Remove cylinder heads. Refer to [EM-88. "Removal and Installation"](#).
9. Remove sub harness, and remove knock sensors.
CAUTION:
Handle sensor carefully; do not shock or drop.
10. Remove piston and connecting rod assembly as follows:
 - Before removing piston and connecting rod assembly, check the connecting rod side clearance. Refer to [EM-112. "Inspection After Disassembly"](#).

CAUTION:

Be careful not to drop connecting rod bearing or to scratch the bearing surface.

11. Position crankshaft pin corresponding to connecting rod to be removed onto the bottom dead center.
12. Remove connecting rod bearing cap.
13. Push piston and connecting rod assembly out of the cylinder head side using suitable tool.

CAUTION:

Be careful not to damage the cylinder wall or crankshaft pin resulting from an interference of the connecting rod big end.

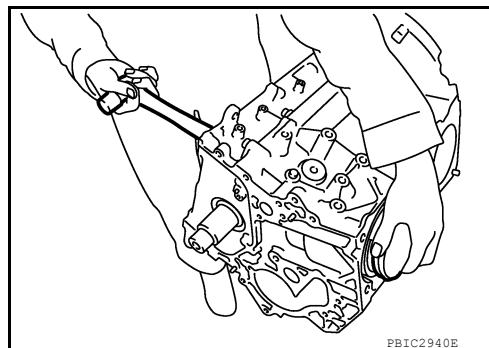

14. Remove connecting rod bearings from connecting rod and connecting rod bearing cap.

CAUTION:

Identify installation position, and store them without mixing them up.

15. Remove piston rings from piston.
 - Before removing piston rings, check the piston ring side clearance. Refer to [EM-112. "Inspection After Disassembly"](#).
 - Remove piston rings using piston ring expander or suitable tool.

CAUTION:

- **When removing piston rings, be careful not to damage piston.**
- **Be careful not to damage piston rings by expanding them excessively.**

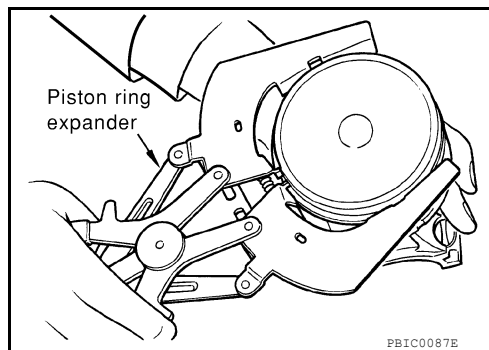

16. Remove piston from connecting rod as follows:

- a. Remove snap ring using snap ring pliers.

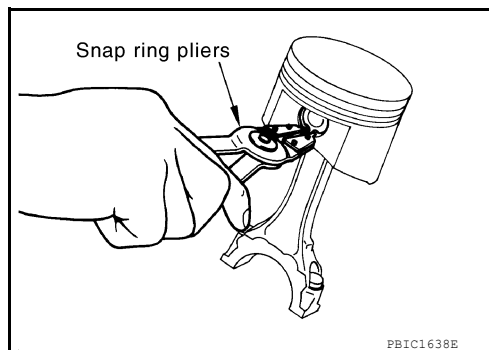

ENGINE UNIT

< UNIT DISASSEMBLY AND ASSEMBLY >

[VQ40DE]

- b. Heat piston to 60° to 70°C (140° to 158°F) with industrial use drier or equivalent.

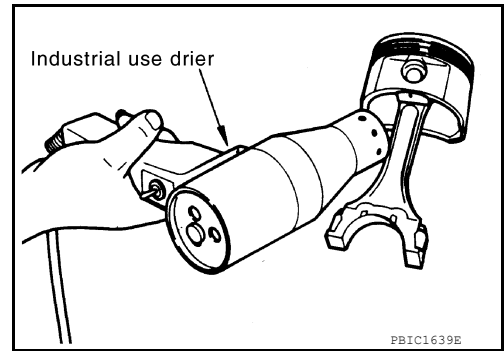

- c. Push out piston pin with drift which has an outer diameter of approximately 20 mm (0.79 in).

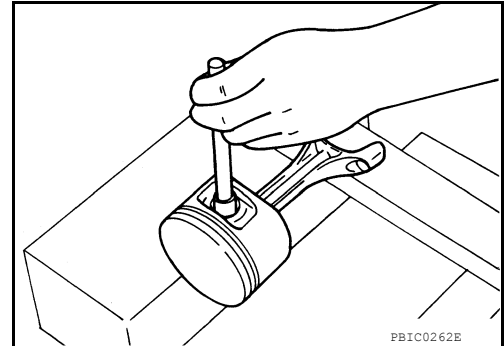

17. Remove lower cylinder block bolts.
- Before loosening lower cylinder block bolts, measure the crankshaft end play. Refer to [EM-112. "Inspection After Disassembly"](#).
 - Loosen lower cylinder block bolts in reverse order as shown in several different steps.

NOTE:

Use socket (size E14) for bolts No. 1 to 16 (M10 bolt).

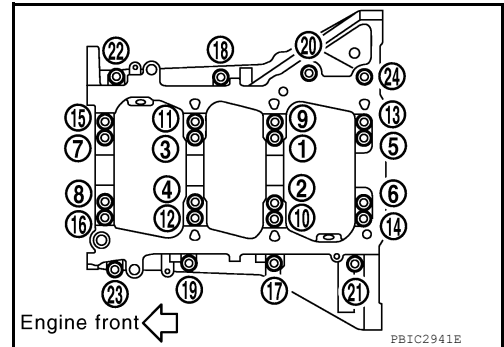

18. Remove lower cylinder block.
- Cut liquid gasket for removal using Tool. Refer to [EM-4. "Precaution for Liquid Gasket"](#).

Tool number : KV10111100 (J-37228)

CAUTION:

Be careful not to damage the mounting surfaces.

19. Remove crankshaft.
20. Pull rear oil seal out from rear end of crankshaft.

NOTE:

When replacing rear oil seal without removing lower cylinder block, use a suitable tool to pull the rear oil seal installed between crankshaft and cylinder block out.

CAUTION:

Be careful not to damage crankshaft or cylinder block.

21. Remove main bearings and thrust bearings from cylinder block and lower cylinder block.

CAUTION:

- **Do not drop main bearing, and to scratch the surface.**
- **Identify installation positions, and store them without mixing them up.**

22. Remove oil jet.

ASSEMBLY

ENGINE UNIT

< UNIT DISASSEMBLY AND ASSEMBLY >

[VQ40DE]

1. Fully air-blow engine coolant and engine oil passages in cylinder block, cylinder bore and crankcase to remove any foreign material.

WARNING:

Use goggles to protect your eyes.

2. Install each plug to cylinder block as shown.
 - Apply sealant to the thread of water drain plugs (A) and (B).
Use Genuine RTV Silicone Sealant or equivalent. Refer to [GI-21, "Recommended Chemical Products and Sealants"](#).
 - Apply sealant to the thread of plugs (C).
Use Genuine High Strength Thread Locking Sealant or equivalent. Refer to [GI-21, "Recommended Chemical Products and Sealants"](#).
 - Apply sealant to the thread of plug (D).
Use Anaerobic Liquid Gasket or equivalent. Refer to [GI-21, "Recommended Chemical Products and Sealants"](#).
 - Replace washers with new washers.

CAUTION:

Do not reuse copper sealing washers.

NOTE:

For Canada, (D) is not plug but block heater. Refer to [EM-103, "Disassembly and Assembly"](#).

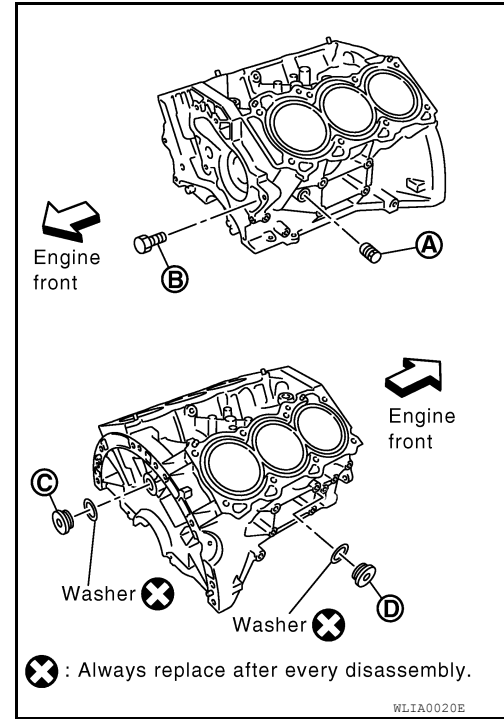

- Tighten each plug as specified below.

Block Plug and Block Heater Installation

Part	Washer	Tightening Torque
A	No	19.6 N·m (2.0 kg-m, 14 ft-lb)
B	Reuse	9.8 N·m (1.0 kg-m, 87 in-lb)
	New	6.0 N·m (0.61 kg-m, 53 in-lb)
C	Yes	116 N·m (11.8 kg-m, 86 ft-lb)
D	Plug	62 N·m (6.3 kg-m, 46 ft-lb)
	Block heater	73.5 N·m (7.5 kg-m, 54 ft-lb)

3. Install oil jet.
 - Insert oil jet dowel pin into cylinder block dowel pin hole, and tighten bolts to specification.

Oil jet bolts : 27.0 N·m (2.8 kg-m, 20 ft-lb)

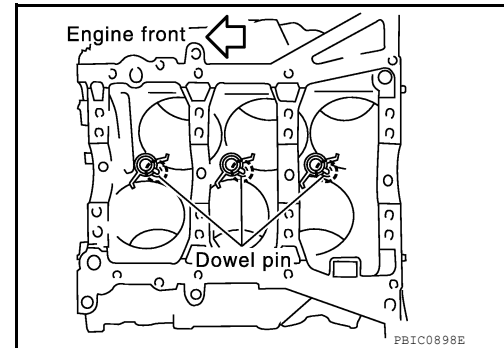

4. Install main bearings and thrust bearings as follows:
 - a. Remove dust, dirt, and engine oil on bearing mating surfaces of cylinder block and main bearing caps.

ENGINE UNIT

[VQ40DE]

< UNIT DISASSEMBLY AND ASSEMBLY >

- b. Install thrust bearings to the both sides of the No. 3 journal housing on cylinder block.
 - Install thrust bearings with the oil groove facing crankshaft arm (outside).
 - Install thrust bearing with a projection on one end on cylinder block. Align projection with mating notch.

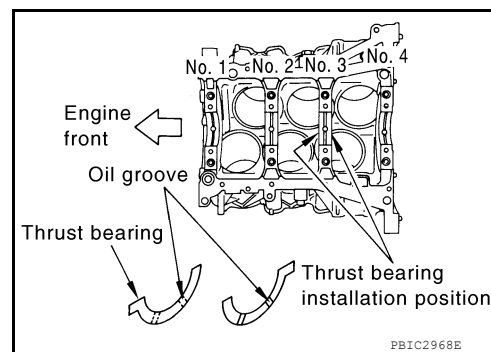

- c. Install main bearings paying attention to the direction.
 - Main bearing with oil hole and groove goes on cylinder block. The one without them goes on lower cylinder block.
 - Before installing main bearings, apply engine oil to the bearing surface (inside). Do not apply engine oil to the back surface, but thoroughly clean it.
 - When installing, align main bearing stopper protrusion to cut-out of cylinder block and lower cylinder block.
 - Ensure the oil holes on cylinder block and those on the corresponding bearing are aligned.

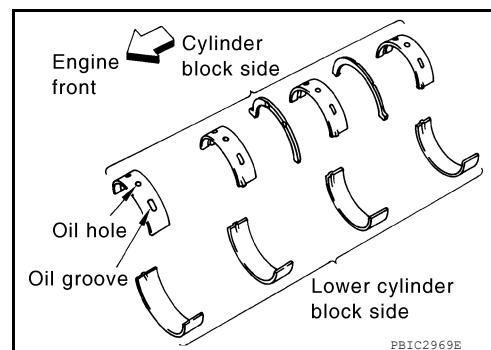

5. Install crankshaft to cylinder block.
 - While turning crankshaft by hand, check that it turns smoothly.
6. Inspect the outer diameter of lower cylinder block bolt. Refer to [EM-112. "Inspection After Disassembly"](#).
7. Install lower cylinder block as follows:

NOTE:

Lower cylinder block cannot be replaced as a single part, because it is machined together with cylinder block.

- a. Apply a continuous bead of liquid gasket using suitable tool to lower cylinder block as shown.

Use Genuine RTV Silicone Sealant or equivalent. Refer to [GI-21. "Recommended Chemical Products and Sealants"](#).

CAUTION:

After liquid gasket is applied, rear oil seal installation must be finished within 5 minutes. Therefore, the following procedure must be performed quickly.

- b. Tighten lower cylinder block as follows:
 - i. Apply new engine oil to threads and seat surfaces of the bolts.
 - ii. Tighten M8 bolts in numerical order as shown from No. 17 to 24.

Bolts 17 - 24 : 22.1 N·m (2.3 kg·m, 16 ft·lb)

CAUTION:

Wipe off completely any protruding liquid gasket on rear oil seal installation surface.

NOTE:

There are more processes to complete the tightening bolts. However stop procedure here to install rear oil seal.

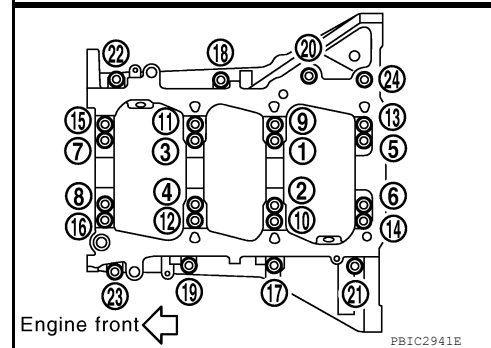
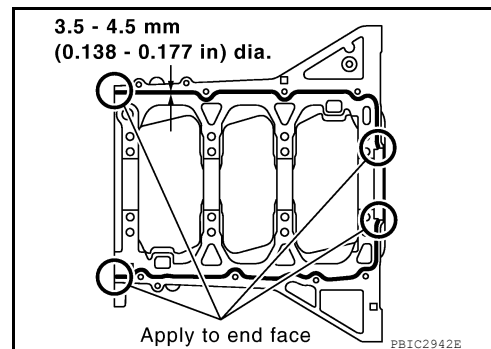

- c. Install rear oil seal. Refer to [EM-86. "Removal and Installation of Rear Oil Seal"](#).
- d. Restart tightening of lower cylinder block bolts as follows:

ENGINE UNIT

< UNIT DISASSEMBLY AND ASSEMBLY >

[VQ40DE]

- i. Tighten M10 bolts in numerical order as shown from No. 1 to 16.

NOTE:

Use socket (size E14) for bolts No. 1 to 16 (M10 bolt).

Bolts 1 - 16 : 35.3 N-m (3.6 kg-m, 26 ft-lb)

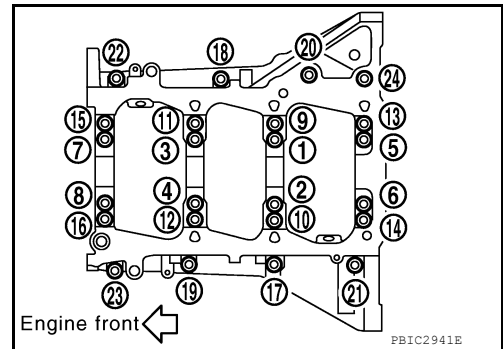

- ii. Turn M10 bolts 90° clockwise in numerical order from No. 1 to 16 using Tool.

Tool number : KV10112100 (BT-8653-A)

CAUTION:

Use angle wrench Tool to check tightening angle. Do not make judgement by visual inspection.

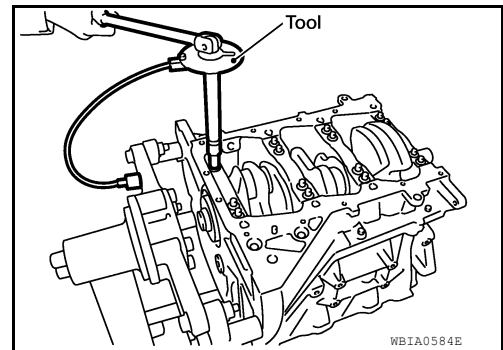

- After installing the bolts, make sure that crankshaft can be rotated smoothly by hand.
- Wipe off completely any protruding liquid gasket on front side of the engine.
- Check the crankshaft end play. Refer to [EM-112. "Inspection After Disassembly"](#).

8. Inspect the outer diameter of connecting rod bolt. Refer to [EM-112. "Inspection After Disassembly"](#).

9. Install piston to connecting rod as follows:

- a. Install new snap ring to the groove of piston rear side using suitable tool.
- Insert it fully into groove to install.

- b. Install piston to connecting rod.

- Using industrial use drier or similar tool, heat piston until piston pin can be pushed in by hand without excess force [approximately 60° to 70 °C (140° to 158 °F)]. From the front to the rear, insert piston pin into piston and connecting rod.
- Assemble so that the front mark on the piston head and the cylinder number on connecting rod are positioned as shown.

- c. Install new snap ring to the groove of the piston front side.

- Insert it fully into groove to install.
- After installing, make sure that connecting rod moves smoothly.

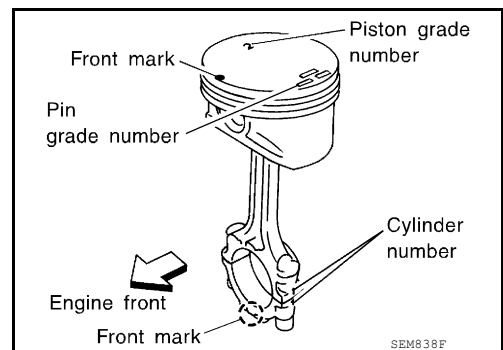

10. Install piston rings using piston ring expander or suitable tool.

CAUTION:

- When installing piston rings, be careful not to damage piston.
- Be careful not to damage piston rings by expending them excessively.

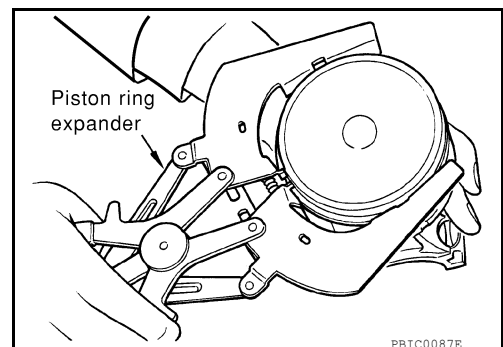

ENGINE UNIT

< UNIT DISASSEMBLY AND ASSEMBLY >

[VQ40DE]

- If there is stamped mark on ring, mount it with marked side up.

NOTE:

If there is no stamp on ring, no specific orientation is required for installation.

Stamped mark:

Top ring : —

Second ring : R

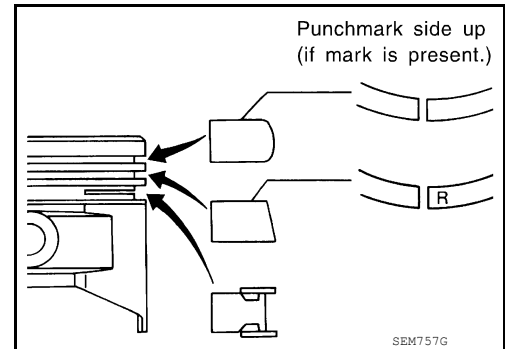

- Position each ring with the gap as shown referring to the piston front mark.

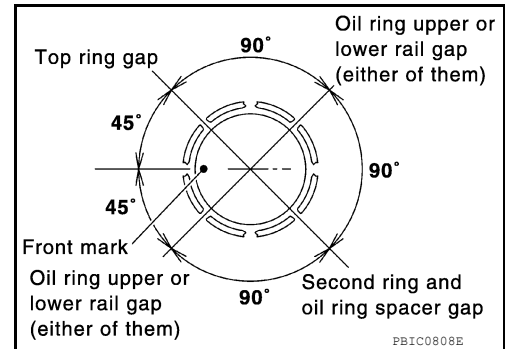

- Check the piston ring side clearance. Refer to [EM-112, "Inspection After Disassembly"](#).

11. Install connecting rod bearings to connecting rod and connecting rod bearing cap.
 - Before installing connecting rod bearings, apply engine oil to the bearing surface (inside). Do not apply engine oil to the back surface, but thoroughly clean it.
 - When installing, align connecting rod bearing stopper protrusion with cutout of connecting rods and connecting rod bearing caps to install.
 - Ensure the oil hole on connecting rod and that on the corresponding bearing are aligned.

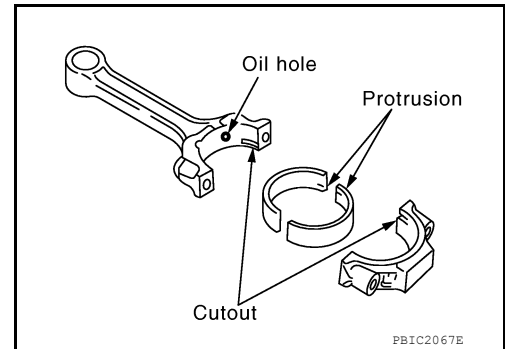

12. Install piston and connecting rod assembly to crankshaft.
13. Position crankshaft pin corresponding to connecting rod to be installed onto the bottom dead center.
14. Apply engine oil sufficiently to the cylinder bore, piston and crankshaft pin journal.
15. Match the cylinder position with the cylinder number on connecting rod to install.

NOTE:

Be sure that front mark on piston head is facing front of engine.

16. Install piston with the front mark on the piston head facing the front of engine using Tool.

Tool number : EM03470000 (J-8037)

CAUTION:

Be careful not to damage the cylinder wall and crankshaft pin, resulting from an interference of the connecting rod big end.

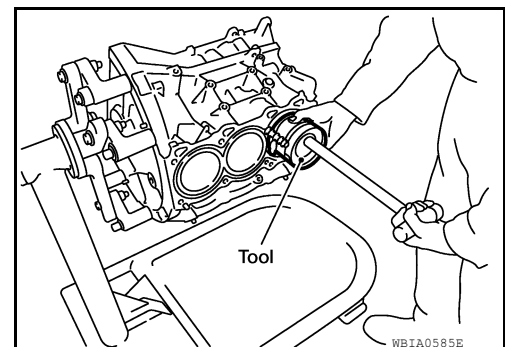

ENGINE UNIT

< UNIT DISASSEMBLY AND ASSEMBLY >

[VQ40DE]

17. Install connecting rod bearing cap.

- Match the stamped cylinder number marks on connecting rod with those on connecting rod bearing cap to install.
- Be sure that front mark on connecting rod bearing cap is facing front of engine.

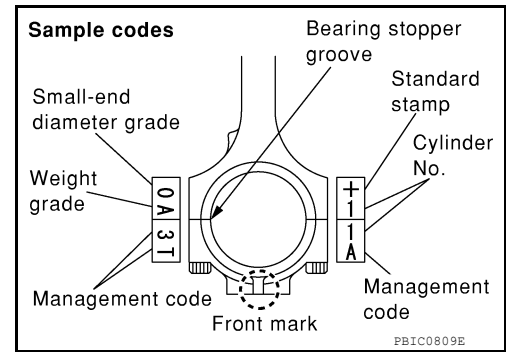

18. Tighten connecting rod bolts in two steps as follows:

- a. Apply engine oil to the threads and seats of connecting rod bolts. Tighten the connecting rod bolts to specification

Connecting rod bolt : 19.6 N·m (2.0 kg-m, 14 ft-lb)

- b. Then tighten (turning clockwise) all connecting rod bolts 90° using Tool.

Tool number : KV10112100 (BT-8653-A)

CAUTION:

Always use Tool. Avoid tightening based on visual check alone.

- After tightening connecting rod bolts, make sure that crankshaft rotates smoothly.
- Check the connecting rod side clearance. Refer to [EM-112](#), "[Inspection After Disassembly](#)".

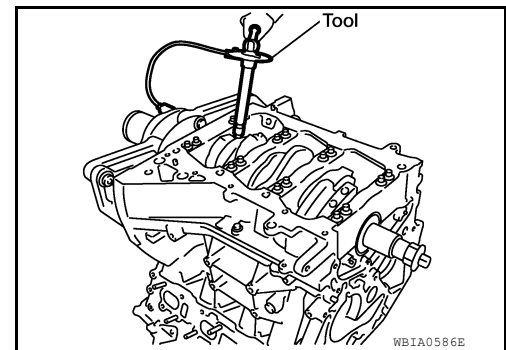

19. Install knock sensors.

- Install knock sensor so that harness connector faces rear of engine.
- After installing knock sensor, connect harness connector, and lay it out to rear of engine.

Knock sensor bolts : 18.1 N·m (1.8 kg-m, 13 ft-lb)

CAUTION:

- Do not tighten bolts while holding harness connector.
- If knock sensor is dropped, replace it with new one.

NOTE:

- Make sure that there is no foreign material on the cylinder block mating surface and the back surface of knock sensor.
- Make sure that knock sensor does not interfere with other parts.

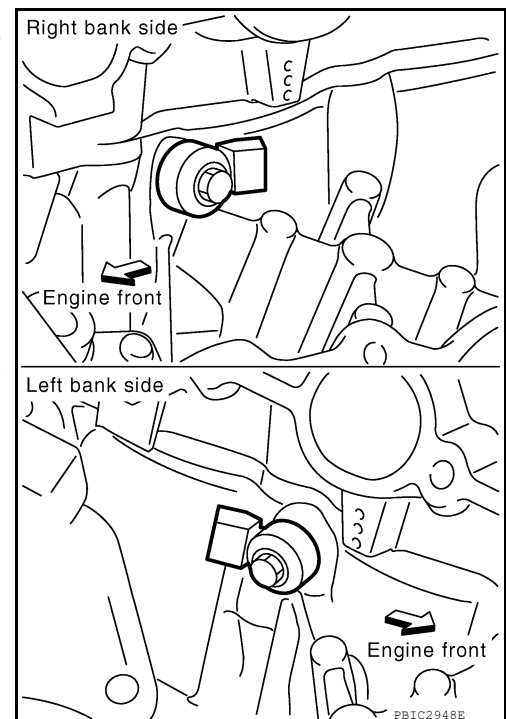

20. Assembly is in the reverse order of disassembly after this step.

Flywheel (M/T models)

- Install flywheel.

ENGINE UNIT

< UNIT DISASSEMBLY AND ASSEMBLY >

[VQ40DE]

Pilot converter (A/T models)

- Install pilot converter.
- With drift of the following outer diameter, press-fit as far as it will go.

Pilot converter : Approximately 33 mm (1.30 in)

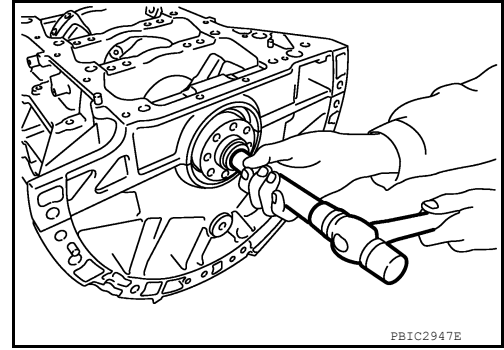

- Press-fit pilot converter with its chamfer facing crankshaft as shown.

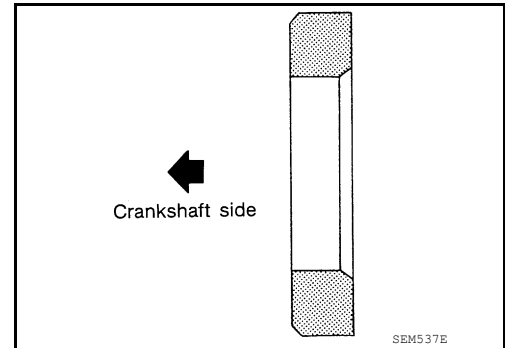

Drive plate (A/T models)

- Install drive plate and reinforcement plate as shown.
- Hold ring gear using Ring Gear Stopper Tool.

Tool number : KV11105210 (J-44716)

- Tighten bolts crosswise over several times.

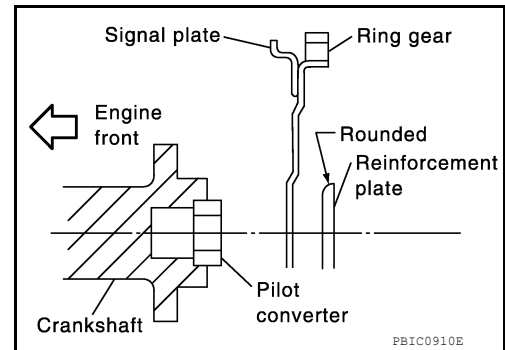

INFOID:000000011069733

Inspection After Disassembly

CRANKSHAFT END PLAY

- Measure the clearance between thrust bearings and crankshaft arm when crankshaft is moved fully forward or backward with dial indicator.

Standard : 0.10 - 0.25 mm (0.0039 - 0.0098 in)

Limit : 0.30 mm (0.0118 in)

- If the measured value exceeds the limit, replace thrust bearings, and measure again. If it still exceeds the limit, replace crankshaft also.

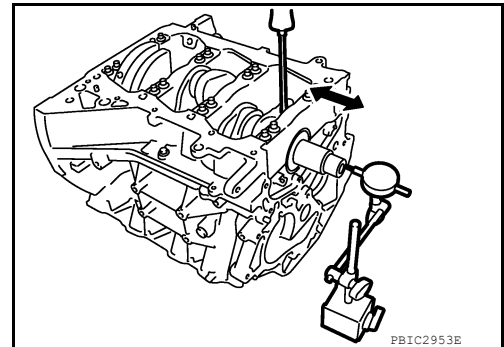

CONNECTING ROD SIDE CLEARANCE

ENGINE UNIT

[VQ40DE]

< UNIT DISASSEMBLY AND ASSEMBLY >

- Measure the side clearance between connecting rod and crankshaft arm with feeler gauge.

Standard : 0.20 - 0.35 mm (0.0079 - 0.0138 in)

Limit : 0.40 mm (0.0157 in)

- If the measured value exceeds the limit, replace connecting rod, and measure again. If it still exceeds the limit, replace crankshaft also.

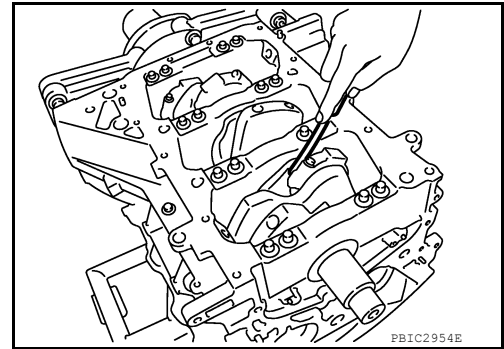

PISTON TO PISTON PIN CLEARANCE

Piston Pin Hole Diameter

Measure the inner diameter of piston pin hole with inside micrometer.

Standard : 21.993 - 22.005 mm (0.8659 - 0.8663 in)

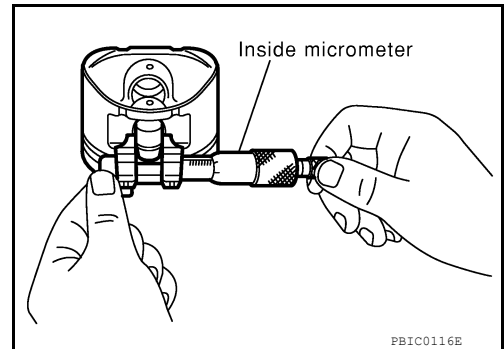

Piston Pin Outer Diameter

Measure the outer diameter of piston pin with micrometer.

Standard : 21.989 - 22.001 mm (0.8657 - 0.8662 in)

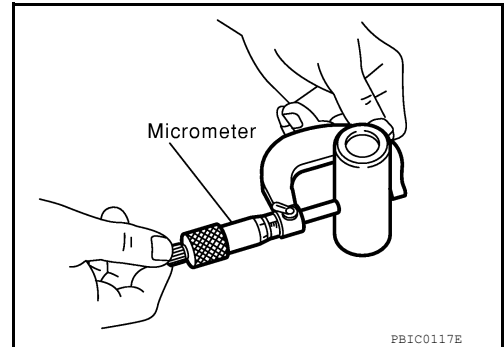

Piston to Piston Pin Oil Clearance

(Piston to piston pin oil clearance) = (Piston pin hole diameter) – (Piston pin outer diameter)

Standard : 0.002 - 0.006 mm (0.0001 - 0.0002 in)

- If the calculated value is out of the standard, replace piston and piston pin assembly.
- When replacing piston and piston pin assembly. Refer to [EM-125. "How to Select Piston and Bearing"](#).

NOTE:

- Piston is available together with piston pin as assembly.
- Piston pin (piston pin hole) grade is provided only for the parts installed at the plant. For service parts, no piston pin grades can be selected. (Only "0" grade is available.)

PISTON RING SIDE CLEARANCE

ENGINE UNIT

< UNIT DISASSEMBLY AND ASSEMBLY >

[VQ40DE]

- Measure side clearance of piston ring and piston ring groove with feeler gauge.

Standard:

- Top ring** : 0.045 - 0.080 mm (0.0018 - 0.0031 in)
- 2nd ring** : 0.030 - 0.070 mm (0.0012 - 0.0028 in)
- Oil ring** : 0.065 - 0.135 mm (0.0026 - 0.0053 in)

Limit:

- Top ring** : 0.11 mm (0.0043 in)
- 2nd ring** : 0.10 mm (0.0039 in)

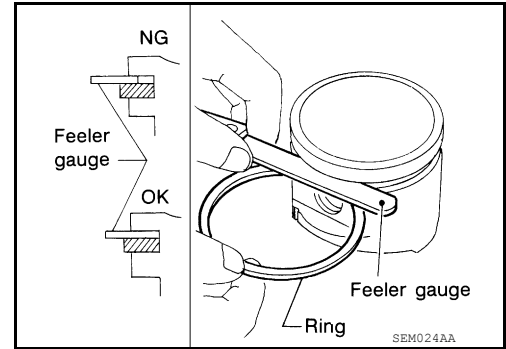

- If the measured value exceeds the limit, replace piston ring, and measure again. If it still exceeds the limit, replace piston also.

PISTON RING END GAP

- Make sure that the cylinder bore inner diameter is within the specification. Follow the "Cylinder Bore Inner Diameter" procedure.
- Lubricate with new engine oil to piston and piston ring, and then insert piston ring until middle of cylinder with piston, and measure the piston ring end gap with feeler gauge.

Standard:

- Top ring** : 0.23 - 0.33 mm (0.0091 - 0.0130 in)
- 2nd ring** : 0.33 - 0.48 mm (0.0130 - 0.0189 in)
- Oil ring** : 0.20 - 0.50 mm (0.0079 - 0.0197 in)

Limit:

- Top ring** : 0.56 mm (0.0220 in)
- 2nd ring** : 0.68 mm (0.0268 in)
- Oil ring** : 0.85 mm (0.0335 in)

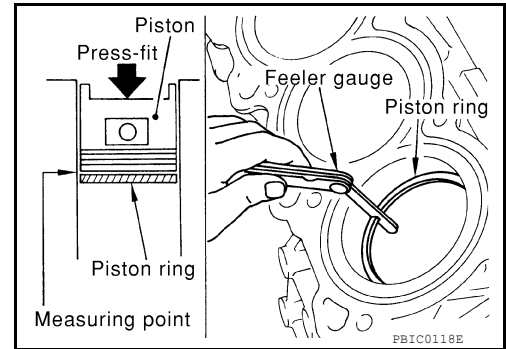

- If the measured value exceeds the limit, replace piston ring, and measure again.

CONNECTING ROD BEND AND TORSION

ENGINE UNIT

< UNIT DISASSEMBLY AND ASSEMBLY >

[VQ40DE]

- Check with connecting rod aligner.

Bend:

Limit: 0.15 mm (0.0059 in) per 100 mm (3.94 in) length

Torsion:

Limit: 0.30 mm (0.0118 in) per 100 mm (3.94 in) length

- If it exceeds the limit, replace connecting rod assembly.

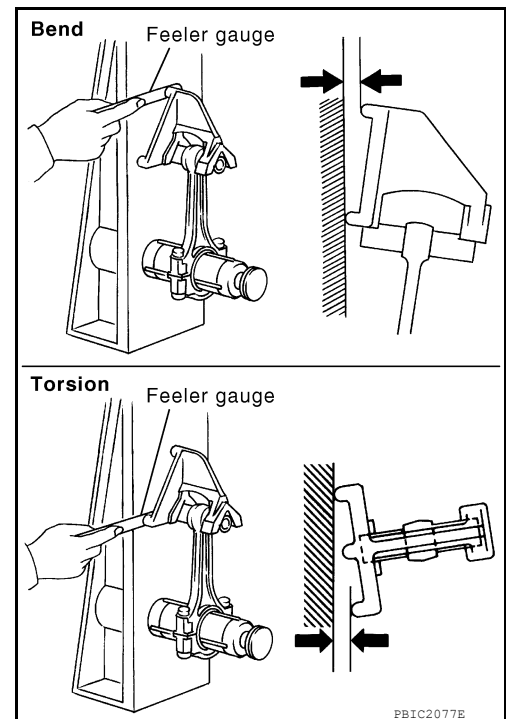

CONNECTING ROD DIAMETER (BIG END)

- Install connecting rod bearing cap without installing connecting rod bearing, and tightening connecting rod bolts to the specified torque. Refer to [EM-103, "Disassembly and Assembly"](#) for the tightening procedure.
- Measure the inner diameter of connecting rod big end with inside micrometer.

Standard : 57.000 - 57.013 mm (2.2441 - 2.2446 in)

- If out of the standard, replace connecting rod assembly.

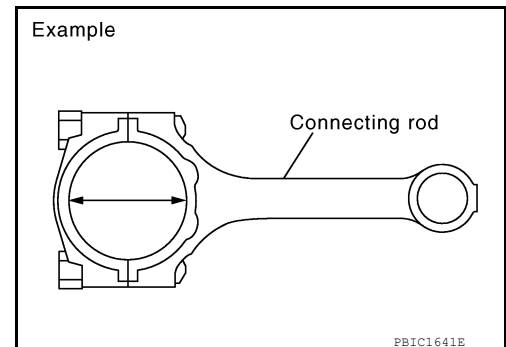

CONNECTING ROD BUSHING OIL CLEARANCE (SMALL END)

Connecting Rod Bushing Inside Diameter (Small End)

Measure inside diameter of connecting rod bushing using suitable tool.

Standard : 22.000 - 22.012 mm (0.8661 - 0.8666 in)

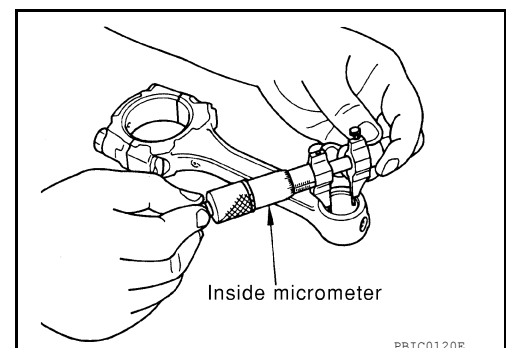

Piston Pin Diameter

ENGINE UNIT

< UNIT DISASSEMBLY AND ASSEMBLY >

[VQ40DE]

Measure diameter of piston pin using suitable tool.

Standard : 21.989 - 22.001 mm (0.8657 - 0.8662 in)

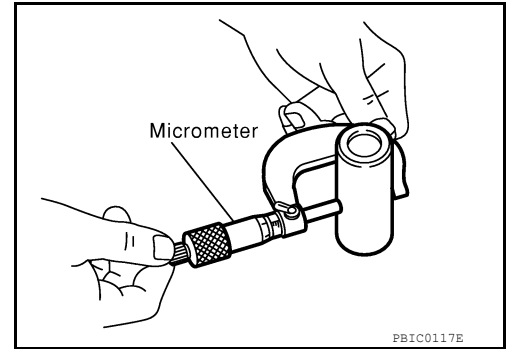

Connecting Rod Bushing Oil Clearance (Small End)

(Connecting rod bushing oil clearance) = (Connecting rod bushing inner diameter) – (Piston pin outer diameter)

Standard : 0.005 - 0.017 mm (0.0002 - 0.0007 in)

Limit : 0.030 mm (0.0012 in)

- If the calculated value exceeds the limit, replace connecting rod assembly and/or piston and piston pin assembly.
- If replacing piston and piston pin assembly. Refer to [EM-125. "How to Select Piston and Bearing"](#).
- If replacing connecting rod assembly, follow the "CONNECTING ROD BEARING OIL CLEARANCE" procedure to select the connecting rod bearing.

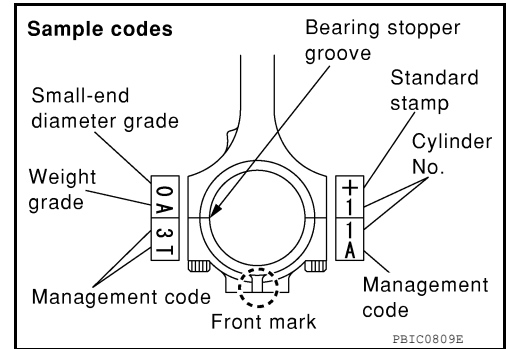

Factory installed parts grading:

- Only grade "0".

Grade	Unit: mm (in)	
	0	1
Connecting rod bushing inner diameter *	22.000 - 22.006 (0.8661 - 0.8664)	22.006 - 22.012 (0.8664 - 0.8666)
Piston pin hole diameter	21.993 - 21.999 (0.8659 - 0.8661)	21.999 - 22.005 (0.8661 - 0.8663)
Piston pin outer diameter	21.989 - 21.995 (0.8657 - 0.8659)	21.995 - 22.001 (0.8659 - 0.8662)

*: After installing in connecting rod

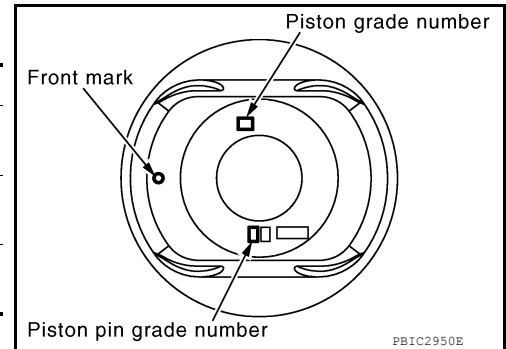

CYLINDER BLOCK DISTORTION

- Remove any oil, scale, gasket, sealant and carbon deposits from the cylinder block surface.

CAUTION:

Do not allow any debris to enter engine oil or engine coolant passages.

ENGINE UNIT

< UNIT DISASSEMBLY AND ASSEMBLY >

[VQ40DE]

- Measure the distortion on the cylinder block upper face at some different points in six directions with straightedge and feeler gauge.

Limit : 0.1 mm (0.004 in)

- If it exceeds the limit, replace cylinder block.

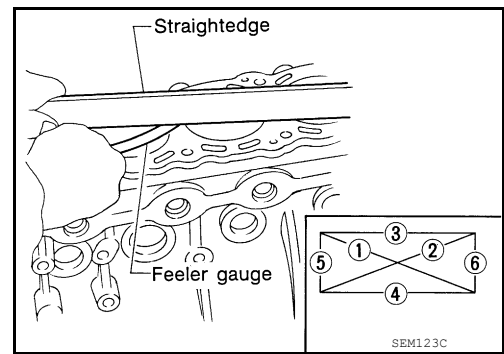

MAIN BEARING HOUSING INNER DIAMETER

- Install lower cylinder block without installing main bearings, and tighten lower cylinder block bolts to the specified torque. Refer to [EM-103, "Disassembly and Assembly"](#) for the tightening procedure.
- Measure the inner diameter of main bearing housing with bore gauge.

Standard : 74.993 - 75.017 mm (2.9525 - 2.9534 in)

- If out of the standard, replace cylinder block and lower cylinder block as assembly.

NOTE:

Cylinder block cannot be replaced as a single part, because it is machined together with lower cylinder block.

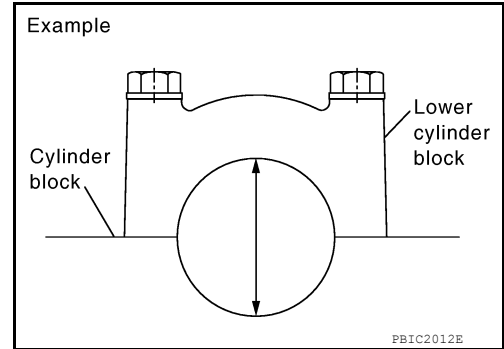

PISTON TO CYLINDER BORE CLEARANCE

Cylinder Bore Inner Diameter

- Using bore gauge, measure cylinder bore for wear, out-of-round and taper at six different points on each cylinder. [(X) and (Y) directions at (A), (B) and (C)] [(X) is in longitudinal direction of engine].

Standard inner diameter:

95.500 - 95.530 mm (3.7598 - 3.7610 in)

Out-of-round [Difference between (X) and (Y)]:

0.015 mm (0.0006 in)

Taper limit [Difference between (A) and (C)]:

0.01 mm (0.0004 in)

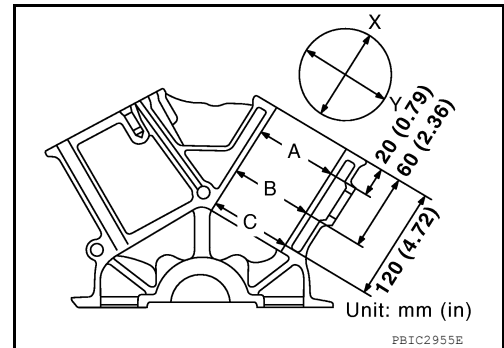

- If the measured value exceeds the limit, or if there are scratches and/or seizure on the cylinder inner wall, hone or re-bore the inner wall.

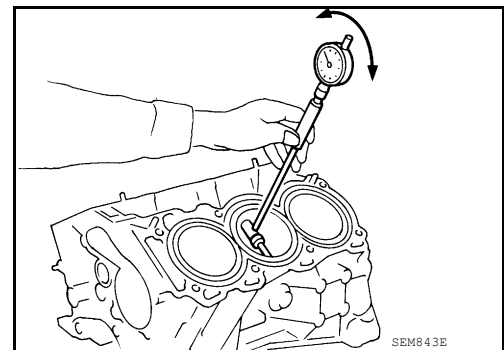

Piston Skirt Diameter

ENGINE UNIT

< UNIT DISASSEMBLY AND ASSEMBLY >

[VQ40DE]

Measure the outer diameter of piston skirt with micrometer.

Measure point

: Distance from the top 43.03 mm (1.6941 in)

Standard

: 95.480 - 95.510 mm (3.7590 - 3.7602 in)

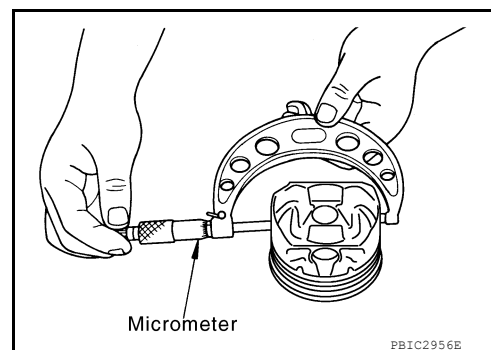

Piston to Cylinder Bore Clearance

Calculate by piston skirt diameter and cylinder bore inner diameter [direction (X), position (B)].

(Clearance) = (Cylinder bore inner diameter) – (Piston skirt diameter).

Standard : 0.010 - 0.030 mm (0.0004 - 0.0012 in)

Limit : 0.08 mm (0.0031 in)

- If the calculated value exceeds the limit, replace piston and piston pin assembly. Refer to [EM-125, "How to Select Piston and Bearing"](#).

Re-boring Cylinder Bore

1. Cylinder bore size is determined by adding piston to cylinder bore clearance to piston skirt diameter.

Re-bored size calculation: $D = A + B - C$

where,

D: Bored diameter

A: Piston skirt diameter as measured

B: Piston to cylinder bore clearance (standard value)

C: Honing allowance 0.02 mm (0.0008 in)

2. Install lower cylinder block, and tighten to the specified torque. Otherwise, cylinder bores may be distorted in final assembly.
3. Cut cylinder bores.
NOTE:
 - When any cylinder needs boring, all other cylinders must also be bored.
 - Do not cut too much out of cylinder bore at a time. Cut only 0.05 mm (0.0020 in) or so in diameter at a time.
4. Hone cylinders to obtain the specified piston to cylinder bore clearance.
5. Measure finished the cylinder bore for out-of-round and taper.

NOTE:

Measurement should be done after cylinder bore cools down.

CRANKSHAFT MAIN JOURNAL DIAMETER

- Measure the outer diameter of crankshaft main journals with micrometer.

Standard : 69.951 - 69.975 mm (2.7540 - 2.7549 in) dia.

- If out of the standard, measure the main bearing oil clearance. Then use undersize bearing.

CRANKSHAFT PIN JOURNAL DIAMETER

ENGINE UNIT

< UNIT DISASSEMBLY AND ASSEMBLY >

[VQ40DE]

- Measure the outer diameter of crankshaft pin journal with micrometer.

Standard : 53.956 - 53.974 mm (2.1242 - 2.1250 in) dia.

- If out of the standard, measure the connecting rod bearing oil clearance. Then use undersize bearing.

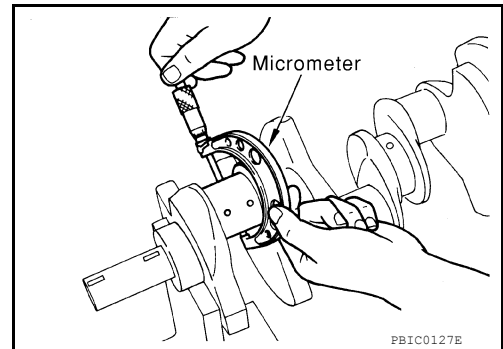

OUT-OF-ROUND AND TAPER OF CRANKSHAFT

- Measure the dimensions at four different points as shown on each main journal and pin journal with micrometer.
- Out-of-round is indicated by the difference in the dimensions between (X) and (Y) at (A) and (B).
- Taper is indicated by the difference in the dimensions between (A) and (B) at (X) and (Y).

Limit:

**Out-of-round [Difference between (X) and (Y)]
: 0.002 mm (0.0001 in)**

**Taper [Difference between (A) and (B)]
: 0.002 mm (0.0001 in)**

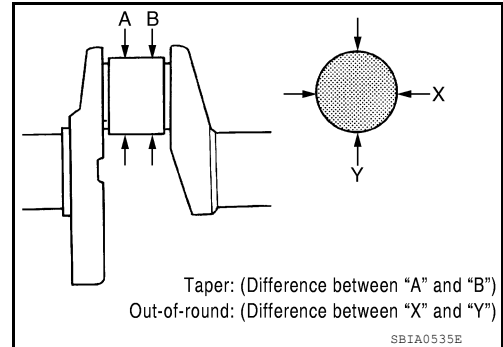

- If the measured value exceeds the limit, correct or replace crankshaft.
- If corrected, measure the bearing oil clearance of the corrected main journal and/or pin journal. Then select the main bearing and/or connecting rod bearing.

CRANKSHAFT RUNOUT

- Place V-block on precise flat table, and support the journals on both ends of crankshaft.
- Place dial indicator straight up on the No. 3 journal.
- While rotating crankshaft, read the movement of the pointer on dial indicator. (Total indicator reading)

Standard : Less than 0.05 mm (0.002 in)

Limit : 0.10 mm (0.0039 in)

- If it exceeds the limit, replace crankshaft.

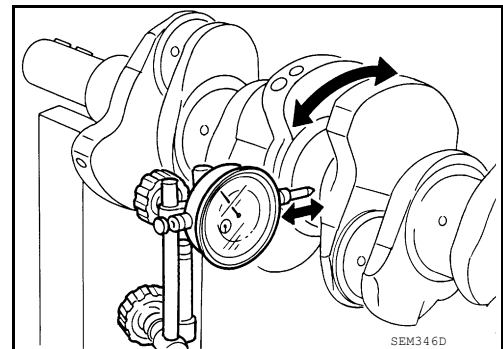

CONNECTING ROD BEARING OIL CLEARANCE

Method by Calculation

- Install connecting rod bearings to connecting rod and cap, and tighten connecting rod bolts to the specified torque. Refer to [EM-103, "Disassembly and Assembly"](#) for the tightening procedure.
- Measure the inner diameter of connecting rod bearing with inside micrometer.

(Bearing oil clearance) = (Connecting rod bearing inner diameter) – (Crankshaft pin journal diameter)

Standard : 0.034 - 0.059 mm (0.0013 - 0.0023 in) (actual clearance)

Limit : 0.070 mm (0.0028 in)

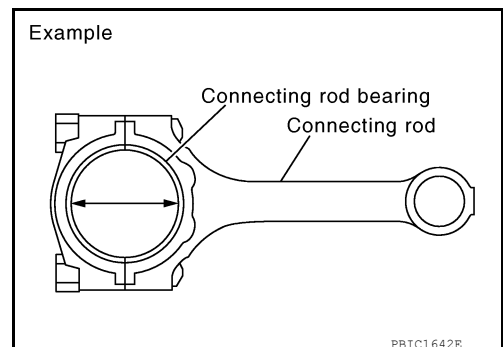

- If the calculated value exceeds the limit, select proper connecting rod bearing according to connecting rod big end diameter and crankshaft pin journal diameter to obtain the specified bearing oil clearance. Refer to [EM-125, "How to Select Piston and Bearing"](#).

ENGINE UNIT

< UNIT DISASSEMBLY AND ASSEMBLY >

[VQ40DE]

Method of Using Plastigage

- Remove oil and dust on crankshaft pin journal and the surfaces of each bearing completely.
- Cut plastigage slightly shorter than the bearing width, and place it in crankshaft axial direction, avoiding oil holes.
- Install connecting rod bearings to connecting rod and cap, and tighten connecting rod bolts to the specified torque. Refer to [EM-103, "Disassembly and Assembly"](#) for the tightening procedure.

CAUTION:

Do not rotate crankshaft.

- Remove connecting rod bearing cap and bearing, and using scale on plastigage bag, measure the plastigage width.

NOTE:

The procedure when the measured value exceeds the limit is same as that described in the "Method by Calculation".

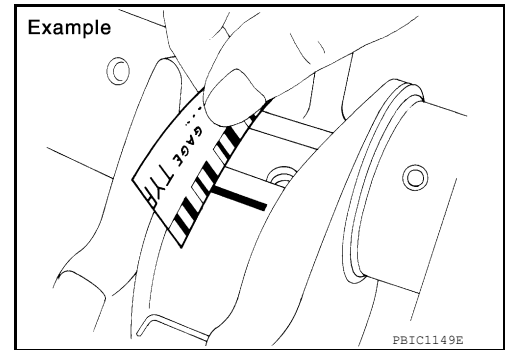

MAIN BEARING OIL CLEARANCE

Method by Calculation

- Install main bearings to cylinder block and lower cylinder block, and tighten lower cylinder block bolts to the specified torque. Refer to [EM-103, "Disassembly and Assembly"](#) for the tightening procedure.
- Measure the inner diameter of main bearing with bore gauge.
(Bearing clearance) = (Main bearing inner diameter) – (Crankshaft main journal diameter)

Standard : 0.035 - 0.045 mm (0.0014 - 0.0018 in)
(actual clearance)

Limit : 0.065 mm (0.0026 in)

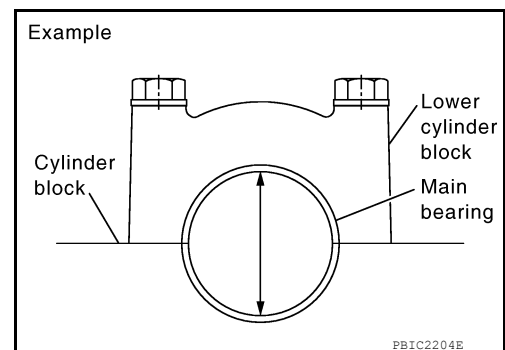

- If the calculated value exceeds the limit, select proper main bearing according to main bearing inner diameter and crankshaft main journal diameter to obtain specified bearing oil clearance. Refer to [EM-125, "How to Select Piston and Bearing"](#).

Method of Using Plastigage

- Remove engine oil and dust on crankshaft main journal and the surfaces of each bearing completely.
- Cut plastigage slightly shorter than the bearing width, and place it in crankshaft axial direction, avoiding oil holes.
- Install main bearings to cylinder block and lower cylinder block, and tighten lower cylinder block bolts to the specified torque. Refer to [EM-103, "Disassembly and Assembly"](#) for the tightening procedure.

CAUTION:

Do not rotate crankshaft.

- Remove lower cylinder block and bearings, and using scale on plastigage bag, measure the plastigage width.

NOTE:

The procedure when the measured value exceeds the limit is same as that described in the "Method by Calculation".

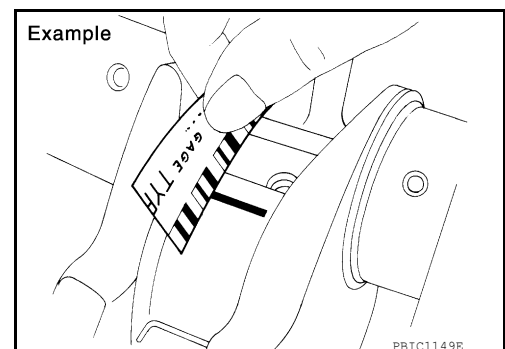

CRUSH HEIGHT OF MAIN BEARING

ENGINE UNIT

< UNIT DISASSEMBLY AND ASSEMBLY >

[VQ40DE]

- When lower cylinder block is removed after being tightened to the specified torque with main bearings installed, the tip end of bearing must protrude. Refer to [EM-103. "Disassembly and Assembly"](#) for the tightening procedure.

Standard : There must be crush height.

- If the standard is not met, replace main bearings.

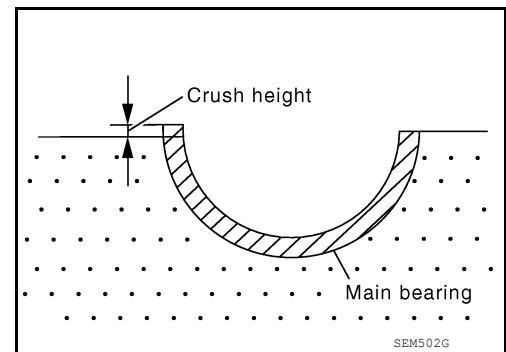

CRUSH HEIGHT OF CONNECTING ROD BEARING

- When connecting rod bearing cap is removed after being tightened to the specified torque with connecting rod bearings installed, the tip end of bearing must protrude. Refer to [EM-103. "Disassembly and Assembly"](#) for the tightening procedure.

Standard : There must be crush height.

- If the standard is not met, replace connecting rod bearings.

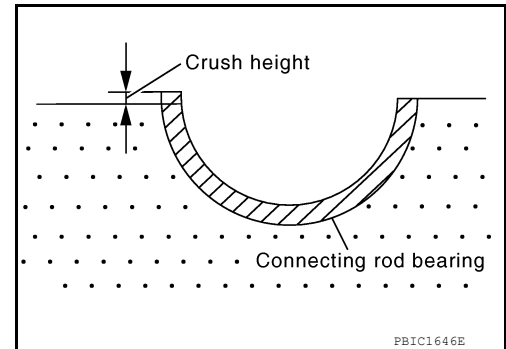

LOWER CYLINDER BLOCK BOLT OUTER DIAMETER

- Measure the outer diameters [(d1), (d2)] at two positions as shown.
- If reduction appears in (A) range, regard it as (d2).

Limit [(d1) – (d2)] : 0.11 mm (0.0051 in)

- If it exceeds the limit (large difference in dimensions), replace lower cylinder block bolt with new one.

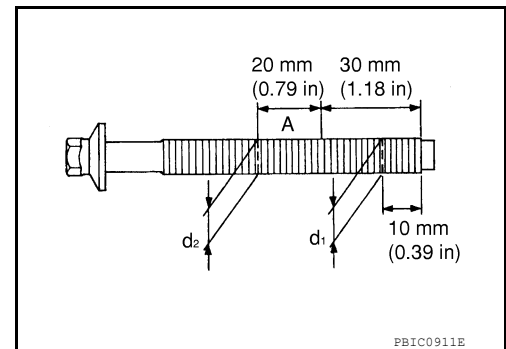

CONNECTING ROD BOLT OUTER DIAMETER

- Measure the outer diameter (d) at position shown.
- If the reduction appears in a position other than (d), regard it as (d).

Limit : 7.75 mm (0.3051 in)

- When (d) exceeds the limit (when it becomes thinner), replace connecting rod bolt with new one.

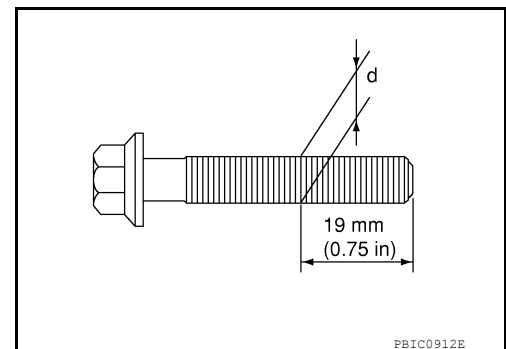

FLYWHEEL RUNOUT (M/T MODELS)

NOTE:

- This inspection is for double mass flywheel only.
- Do not disassemble the double mass flywheel.

Flywheel Deflection

ENGINE UNIT

[VQ40DE]

< UNIT DISASSEMBLY AND ASSEMBLY >

- Measure the deflection of the flywheel contact surface to the clutch with a dial gauge.
- Measure the runout at 210 mm (8.27 in) diameter.

Limit : 0.45 mm (0.0177 in) or less

- When measured value exceeds the limit, replace the flywheel with a new one.

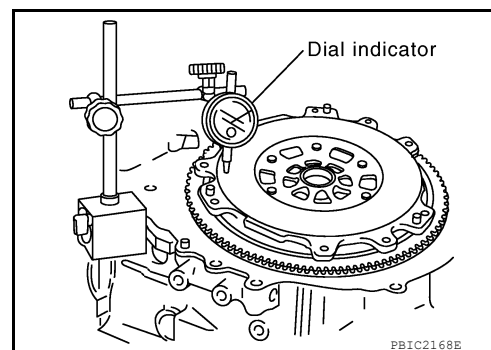

MOVEMENT AMOUNT OF FLYWHEEL (M/T MODELS)

CAUTION:

Do not disassemble double mass flywheel.

Movement Amount of Thrust (Fore-and-Aft) Direction

- Measure the movement amount of thrust (fore-and-aft) direction when 100 N (10.2 kg, 22 lb) force is added at the portion of 125 mm (4.92 in) radius from the center of flywheel.

Standard : 1.3 mm (0.051 in) or less

- If measured value is out of the standard, replace flywheel.

Movement Amount in Radial (Rotation) Direction

Check the movement amount of radial (rotation) direction with the following procedure:

1. Install a bolt to clutch cover mounting hole, and place a torque wrench on the extended line of the flywheel center line.
 - Tighten bolt at a force of 9.8 N·m (1.0 kg-m, 87 in-lb) to keep it from loosening.
2. Put a mating mark on circumferences of the two flywheel masses without applying any load (Measurement standard points).
3. Apply a force of 9.8 N·m (1.0 kg-m, 87 in-lb) in each direction, and mark the movement amount on the mass on the transmission side.
4. Measure the dimensions of movement amounts (A) and (B) on circumference of flywheel on the transmission side.

Standard: 44.3 mm (1.744 in) or less.

- If measured value is out of the standard, replace flywheel.

DRIVE PLATE (A/T MODELS)

- Check drive plate and signal plate for deformation or cracks.

CAUTION:

- **Do not disassemble drive plate.**
- **Do not place drive plate with signal plate facing down.**
- **When handling signal plate, take care not to damage or scratch it.**
- **Handle signal plate in a manner that prevents it from becoming magnetized.**
- If anything is found, replace drive plate.

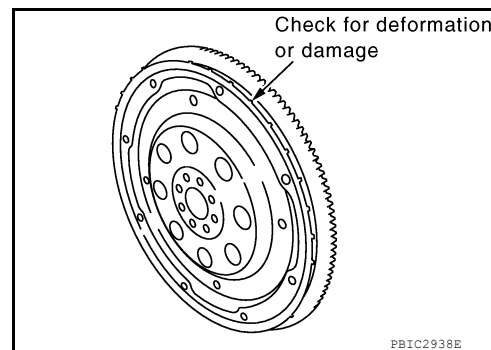
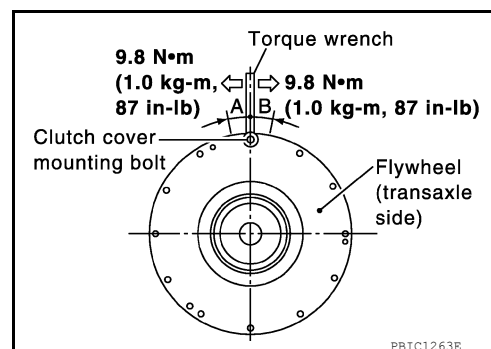

OIL JET

- Check nozzle for deformation and damage.
- Blow compressed air from nozzle, and check for clogs.
- If it is not satisfied, clean or replace oil jet.

OIL JET RELIEF VALVE

ENGINE UNIT

< UNIT DISASSEMBLY AND ASSEMBLY >

[VQ40DE]

- Using clean plastic stick, press check valve in oil jet relief valve. Make sure that valve moves smoothly with proper reaction force.
- If it is not satisfied, replace oil jet relief valve.

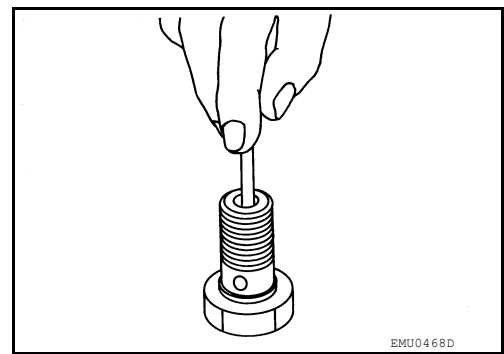

INFOID:000000011069734

Dowel Pin Alignment

REMOVAL

1. Use suitable tool to lock the drive plate (A/T models) or flywheel (M/T models) and match mark (A) the drive plate or flywheel before removing the bolts.

CAUTION:

Do not damage the ring gear teeth, or the signal plate teeth behind the ring gear.

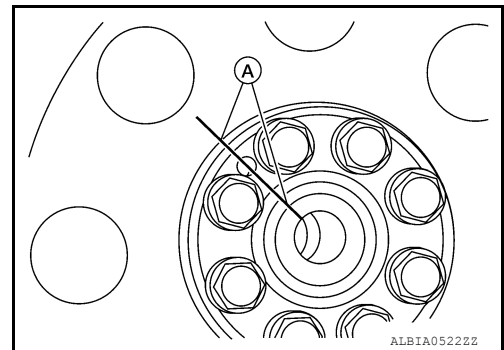

2. Remove drive plate (A/T models) or flywheel (M/T models).
 - Loosen the drive plate or flywheel bolts in a diagonal order.

CAUTION:

- **Do not place drive plate (A/T models) or flywheel (M/T models) with signal plate facing down.**
- **When handling the signal plate, take care not to damage or scratch it.**
- **Handle the signal plate in a manner that prevents it from becoming magnetized**

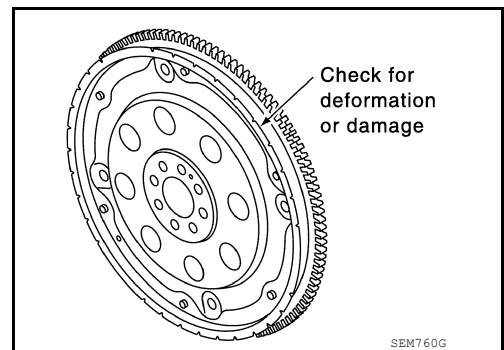

INSTALLATION (A/T MODELS)

1. Installation is in the reverse order of removal.
 - When installing the drive plate to the crankshaft, use the match mark (A) as shown to correctly align the crankshaft side dowel pin to the drive plate side dowel pin hole.

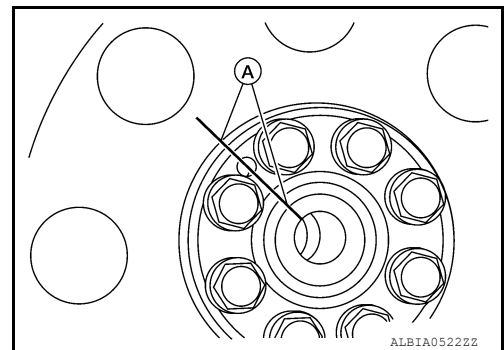

A
EM
C
D
E
F
G
H
I
J
K
L
M
N
O
P

ENGINE UNIT

< UNIT DISASSEMBLY AND ASSEMBLY >

[VQ40DE]

- Install the drive plate and the reinforcement plate in the direction as shown.

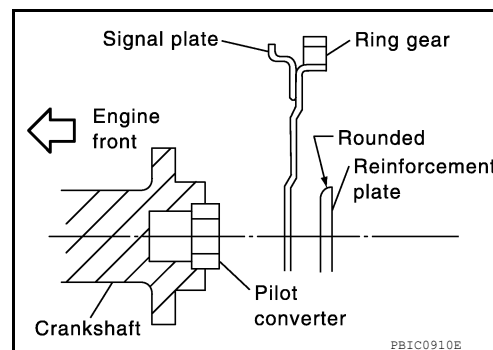

- Tighten the drive plate bolts in a diagonal pattern in two steps. Refer to [EM-102. "Exploded View"](#).

INSTALLATION (M/T MODELS)

1. Installation is in the reverse order of removal after the following.
 - Be sure the dowel pin is installed in the crankshaft.

- When installing the flywheel (3) to the crankshaft (2), be sure to correctly align crankshaft side dowel pin (1) to the flywheel side dowel pin hole (A) as shown.
- Oil seal (4)

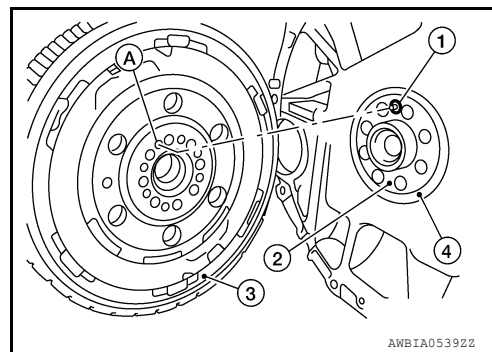

- There is a locator mark (B) on the clutch cover side of the flywheel (4). Refer to this for ease of installation.
- Crankshaft dowel pin (1)
- Oil seal (2)
- Crankshaft (3)
- Flywheel (4)
- Dowel pin hole (A)
- Dowel pin locator mark (B)

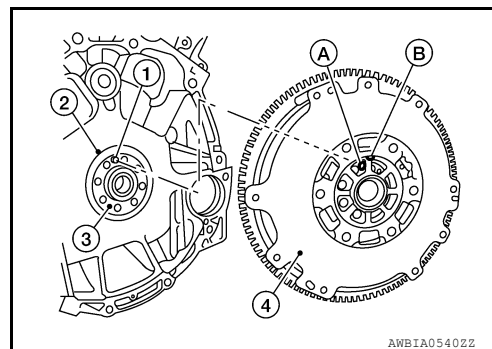

- Tighten the flywheel bolts in a diagonal pattern in two steps. Refer to [EM-103. "Disassembly and Assembly"](#).

HOW TO SELECT PISTON AND BEARING

< UNIT DISASSEMBLY AND ASSEMBLY >

[VQ40DE]

HOW TO SELECT PISTON AND BEARING

How to Select Piston and Bearing

INFOID:0000000011069735

DESCRIPTION

Selection points	Selection parts	Selection items	Selection methods
Between cylinder block and crankshaft	Main bearing	Main bearing grade (bearing thickness)	Determined by match of cylinder block bearing housing grade (inner diameter of housing) and crankshaft journal grade (outer diameter of journal)
Between crankshaft and connecting rod	Connecting rod bearing	Connecting rod bearing grade (bearing thickness)	Combining service grades for connecting rod big end diameter and crankshaft pin outer diameter determine connecting rod bearing selection.
Between cylinder block and piston	Piston and piston pin assembly (Piston is available together with piston pin as assembly.)	Piston grade (piston skirt diameter)	Piston grade = cylinder bore grade (inner diameter of bore)
Between piston and connecting rod*	—	—	—

*: For the service parts, the grade for fitting cannot be selected between piston pin and connecting rod. (Only "0" grade is available.) The information at the shipment from the plant is described as a reference.

- The identification grade stamped on each part is the grade for the dimension measured in new condition. This grade cannot apply to reused parts.
- For reused or repaired parts, measure the dimension accurately. Determine the grade by comparing the measurement with the values of each selection table.
- For details of the measurement method of each part, the reuse standards and the selection method of the selective fitting parts, follow the applicable procedures.

HOW TO SELECT PISTON

When New Cylinder Block is Used

Check the cylinder bore grade [(1), (2), or (3)] on rear side of cylinder block, and select piston of the same grade.

NOTE:

Piston is available with piston pin as a set for the service part. (Only (0) grade piston pin is available.)

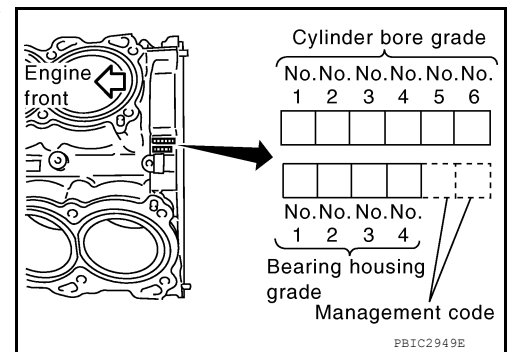

When Cylinder Block is Reused

1. Measure the cylinder bore inner diameter. Refer to [EM-112. "Inspection After Disassembly"](#).
2. Determine the bore grade by comparing the measurement with the values under the cylinder bore inner diameter of the "Piston Selection Table".

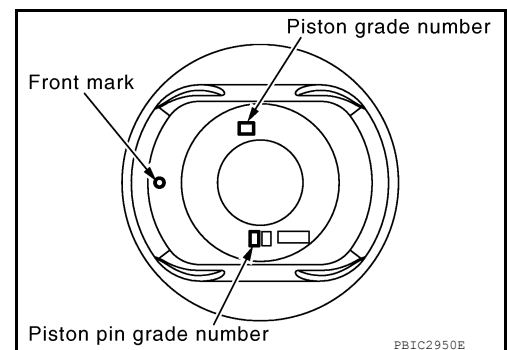

HOW TO SELECT PISTON AND BEARING

< UNIT DISASSEMBLY AND ASSEMBLY >

[VQ40DE]

3. Select piston of the same grade.

Piston Selection Table

Unit: mm (in)

Grade	1	2 (or no mark)	3
Cylinder bore inner diameter	95.500 - 95.510 (3.7598 - 3.7602)	95.510 - 95.520 (3.7602 - 3.7606)	95.520 - 95.530 (3.7606 - 3.7610)
Piston skirt diameter	95.480 - 95.490 (3.7590 - 3.7594)	95.490 - 95.500 (3.7594 - 3.7598)	95.500 - 95.510 (3.7598 - 3.7602)

NOTE:

- Piston is available together with piston pin as assembly.
- Piston pin (piston pin hole) grade is provided only for the parts installed at the plant. For service parts, no piston pin grades can be selected. (Only “0” grade is available.)
- No second grade mark is available on piston.

HOW TO SELECT CONNECTING ROD BEARING

When New Connecting Rod and Crankshaft are Used

Check pin journal grade [(0), (1), or (2)] on front of crankshaft, and select connecting rod bearing of the same grade.

NOTE:

There is no grading for connecting rod big end diameter.

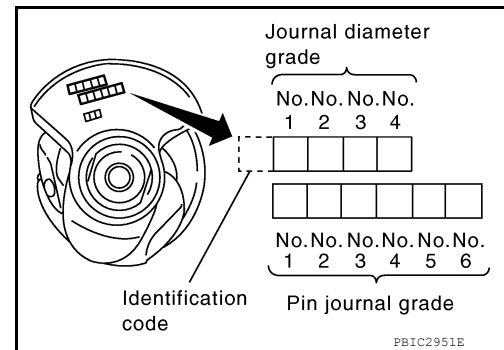

When Crankshaft and Connecting Rod are Reused

1. Measure the connecting rod big end diameter. Refer to [EM-112, "Inspection After Disassembly"](#).
2. Make sure that the connecting rod big end diameter is within the standard value.
3. Measure the crankshaft pin journal diameter. Refer to [EM-112, "Inspection After Disassembly"](#).
4. Determine the grade of crankshaft pin journal grade by corresponding to the measured dimension in “Crankshaft pin journal diameter” column of “Connecting Rod Bearing Selection Table”.
5. Select connecting rod bearing of the same grade.

Connecting Rod Bearing Selection Table

Unit: mm (in)

Connecting rod big end diameter	57.000 - 57.013 (2.2441 - 2.2446)
---------------------------------	-----------------------------------

Unit: mm (in)

Crankshaft		Connecting rod bearing		
Crankshaft pin journal diameter	Grade (Mark)	Dimension (Bearing thickness range)	Bearing grade No.	Color
53.968 - 53.974 (2.1247 - 2.1250)	0	1.500 - 1.503 (0.0591 - 0.0592)	STD 0	Black
53.962 - 53.968 (2.1245 - 2.1247)	1	1.503 - 1.506 (0.0592 - 0.0593)	STD 1	Brown
53.956 - 53.962 (2.1242 - 2.1245)	2	1.506 - 1.509 (0.0593 - 0.0594)	STD 2	Green

Undersize Bearings Usage Guide

- When the specified connecting rod bearing oil clearance is not obtained with standard size connecting rod bearings, use undersize (US) bearings.
- When using undersize (US) bearing, measure the connecting rod bearing inner diameter with bearing installed, and grind crankshaft pin so that the connecting rod bearing oil clearance satisfies the standard.

CAUTION:

HOW TO SELECT PISTON AND BEARING

< UNIT DISASSEMBLY AND ASSEMBLY >

[VQ40DE]

In grinding crankshaft pin to use undersize bearings, keep the fillet R [1.5 - 1.7 mm (0.059 - 0.067 in)].

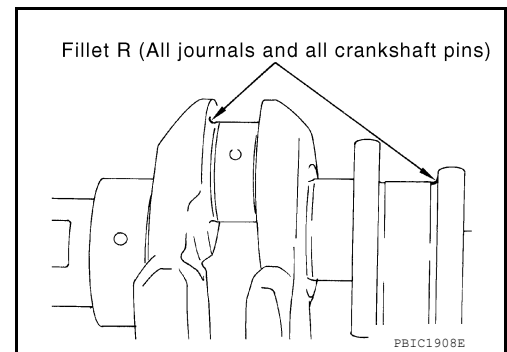

Bearing undersize table

Unit: mm (in)

Size	Thickness
US 0.25 (0.0098)	1.626 - 1.634 (0.0640 - 0.0643)

HOW TO SELECT MAIN BEARING

When New Cylinder Block and Crankshaft are Used

1. "Main Bearing Selection Table" rows correspond to bearing housing grade on rear left side of cylinder block.

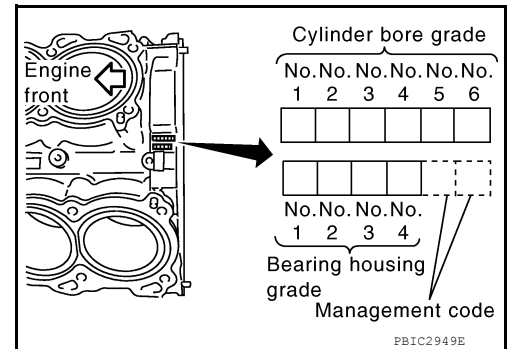

2. "Main Bearing Selection Table" columns correspond to journal diameter grade on front side of crankshaft.

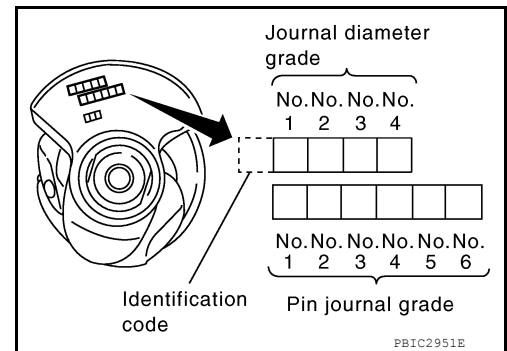

3. Select main bearing grade at the point where selected row and column meet in "Main Bearing Selection Table".

When Cylinder Block and Crankshaft are Reused

1. Measure cylinder block main bearing housing inner diameter and crankshaft main journal diameter. Refer to [EM-112, "Inspection After Disassembly"](#) and [EM-112, "Inspection After Disassembly"](#).
2. Correspond the measured dimension in "Cylinder block main bearing housing inner diameter" row of "Main Bearing Selection Table".
3. Correspond the measured dimension in "Crankshaft main journal diameter" column of "Main Bearing Selection Table".
4. Select main bearing grade at the point where selected row and column meet in following selection table.

HOW TO SELECT PISTON AND BEARING

< UNIT DISASSEMBLY AND ASSEMBLY >

[VQ40DE]

Main Bearing Selection Table

Mark	Axle diameter Unit: mm (in)	Cylinder block main bearing housing inner diameter Unit: mm (in)		Hole diameter																							
		A	B	A	B	C	D	E	F	G	H	J	K	L	M	N	P	R	S	T	U	V	W	X	4	7	
A	69.975 - 69.974 (2.7549 - 2.7549)	0	0	0	0	0	1	0	1	1	1	1	1	1	1	1	1	1	1	1	1	1	1	1	1	1	1
B	69.974 - 69.973 (2.7549 - 2.7548)	0	0	0	1	0	1	1	1	1	1	1	1	1	1	1	1	1	1	1	1	1	1	1	1	1	1
C	69.973 - 69.972 (2.7548 - 2.7548)	0	0	1	0	1	1	1	1	1	1	1	1	1	1	1	1	1	1	1	1	1	1	1	1	1	1
D	69.972 - 69.971 (2.7548 - 2.7548)	0	1	0	1	1	1	1	1	1	1	1	1	1	1	1	1	1	1	1	1	1	1	1	1	1	1
E	69.971 - 69.970 (2.7548 - 2.7547)	0	1	1	1	1	1	1	1	1	1	1	1	1	1	1	1	1	1	1	1	1	1	1	1	1	1
F	69.970 - 69.969 (2.7547 - 2.7547)	0	1	1	1	1	1	1	1	1	1	1	1	1	1	1	1	1	1	1	1	1	1	1	1	1	1
G	69.969 - 69.968 (2.7547 - 2.7546)	1	1	1	1	1	1	1	1	1	1	1	1	1	1	1	1	1	1	1	1	1	1	1	1	1	1
H	69.968 - 69.967 (2.7546 - 2.7546)	1	1	1	1	1	1	1	1	1	1	1	1	1	1	1	1	1	1	1	1	1	1	1	1	1	1
J	69.967 - 69.966 (2.7546 - 2.7546)	1	1	1	1	1	1	1	1	1	1	1	1	1	1	1	1	1	1	1	1	1	1	1	1	1	1
K	69.966 - 69.965 (2.7546 - 2.7545)	1	1	1	1	1	1	1	1	1	1	1	1	1	1	1	1	1	1	1	1	1	1	1	1	1	1
L	69.965 - 69.964 (2.7545 - 2.7545)	1	1	1	1	1	1	1	1	1	1	1	1	1	1	1	1	1	1	1	1	1	1	1	1	1	1
M	69.964 - 69.963 (2.7545 - 2.7544)	1	1	1	1	1	1	1	1	1	1	1	1	1	1	1	1	1	1	1	1	1	1	1	1	1	1
N	69.963 - 69.962 (2.7544 - 2.7544)	2	2	2	2	2	2	2	2	2	2	2	2	2	2	2	2	2	2	2	2	2	2	2	2	2	2
P	69.962 - 69.961 (2.7544 - 2.7544)	2	2	2	2	2	2	2	2	2	2	2	2	2	2	2	2	2	2	2	2	2	2	2	2	2	2
R	69.961 - 69.960 (2.7544 - 2.7543)	2	2	2	2	2	2	2	2	2	2	2	2	2	2	2	2	2	2	2	2	2	2	2	2	2	2
S	69.960 - 69.959 (2.7543 - 2.7543)	2	2	2	2	2	2	2	2	2	2	2	2	2	2	2	2	2	2	2	2	2	2	2	2	2	2
T	69.959 - 69.958 (2.7543 - 2.7542)	2	2	2	2	2	2	2	2	2	2	2	2	2	2	2	2	2	2	2	2	2	2	2	2	2	2
U	69.958 - 69.957 (2.7542 - 2.7542)	2	2	2	2	2	2	2	2	2	2	2	2	2	2	2	2	2	2	2	2	2	2	2	2	2	2
V	69.957 - 69.956 (2.7542 - 2.7542)	3	3	3	3	3	3	3	3	3	3	3	3	3	3	3	3	3	3	3	3	3	3	3	3	3	3
W	69.956 - 69.955 (2.7542 - 2.7541)	3	3	3	3	3	3	3	3	3	3	3	3	3	3	3	3	3	3	3	3	3	3	3	3	3	3
X	69.955 - 69.954 (2.7541 - 2.7541)	3	3	3	3	3	3	3	3	3	3	3	3	3	3	3	3	3	3	3	3	3	3	3	3	3	3
Y	69.954 - 69.953 (2.7541 - 2.7540)	3	3	3	3	3	3	3	3	3	3	3	3	3	3	3	3	3	3	3	3	3	3	3	3	3	3
4	69.953 - 69.952 (2.7540 - 2.7540)	3	3	3	3	3	3	3	3	3	3	3	3	3	3	3	3	3	3	3	3	3	3	3	3	3	3
7	69.952 - 69.951 (2.7540 - 2.7540)	3	3	3	3	3	3	3	3	3	3	3	3	3	3	3	3	3	3	3	3	3	3	3	3	3	3

WBIA0625E

Main Bearing Grade Table (All Journals)

Grade number	Thickness Unit: mm (in)	Width Unit: mm (in)	Identification color	Remarks

HOW TO SELECT PISTON AND BEARING

< UNIT DISASSEMBLY AND ASSEMBLY >

[VQ40DE]

Code	Type	Size Range (mm)	Thickness Range (mm)	Color	Notes
0		2.500 - 2.503 (0.0984 - 0.0985)	19.9 - 20.1 (0.783 - 0.791)	Black	Grade is the same for upper and lower bearings.
1		2.503 - 2.506 (0.0985 - 0.0987)		Brown	
2		2.506 - 2.509 (0.0987 - 0.0988)		Green	
3		2.509 - 2.512 (0.0988 - 0.0989)		Yellow	
4		2.512 - 2.515 (0.0989 - 0.0990)		Blue	
5		2.515 - 2.518 (0.0990 - 0.0991)		Pink	
6		2.518 - 2.521 (0.0991 - 0.0993)		Purple	
7		2.521 - 2.524 (0.0993 - 0.0994)		White	
01	UPR	2.503 - 2.506 (0.0985 - 0.0987)	19.9 - 20.1 (0.783 - 0.791)	Brown	Grade is different for upper and lower bearings.
	LWR	2.500 - 2.503 (0.0984 - 0.0985)		Black	
12	UPR	2.506 - 2.509 (0.0987 - 0.0988)		Green	
	LWR	2.503 - 2.506 (0.0985 - 0.0987)		Brown	
23	UPR	2.509 - 2.512 (0.0988 - 0.0989)		Yellow	
	LWR	2.506 - 2.509 (0.0987 - 0.0988)		Green	
34	UPR	2.512 - 2.515 (0.0989 - 0.0990)		Blue	
	LWR	2.509 - 2.512 (0.0988 - 0.0989)		Yellow	
45	UPR	2.515 - 2.518 (0.0990 - 0.0991)		Pink	
	LWR	2.512 - 2.515 (0.0989 - 0.0990)		Blue	
56	UPR	2.518 - 2.521 (0.0991 - 0.0993)		Purple	
	LWR	2.515 - 2.518 (0.0990 - 0.0991)		Pink	
67	UPR	2.521 - 2.524 (0.0993 - 0.0994)		White	
	LWR	2.518 - 2.521 (0.0991 - 0.0993)		Purple	

Undersize Bearing Usage Guide

- When the specified main bearing oil clearance is not obtained with standard size main bearings, use undersize (US) bearing.
- When using undersize (US) bearing, measure the main bearing inner diameter with bearing installed, and grind main journal so that the main bearing oil clearance satisfies the standard.

CAUTION:

In grinding crankshaft main journal to use undersize bearings, keep the fillet R [1.5 - 1.7 mm (0.059 - 0.067 in)].

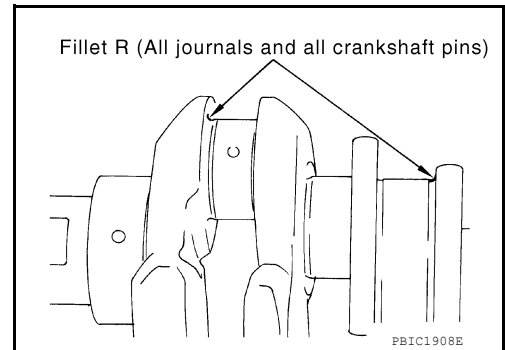

Bearing undersize table

Unit: mm (in)

Size	Thickness
US 0.25 (0.0098)	2.633 - 2.641 (0.1037 - 0.1040)

SERVICE DATA AND SPECIFICATIONS (SDS)

< SERVICE DATA AND SPECIFICATIONS (SDS)

[VQ40DE]

SERVICE DATA AND SPECIFICATIONS (SDS)

SERVICE DATA AND SPECIFICATIONS (SDS)

Standard and Limit

INFOID:0000000011069736

GENERAL SPECIFICATIONS

Cylinder arrangement	V-6	
Displacement cm ³ (cu in)	3,954 (241.30)	
Bore and stroke mm (in)	95.5 × 92.0 (3.76 × 3.622)	
Valve arrangement	DOHC	
Firing order	1-2-3-4-5-6	
Number of piston rings	Compression	2
	Oil	1
Number of main bearings	4	
Compression ratio	9.7	
Compression pressure kPa (kg/cm ² , psi)/300 rpm	Standard	1,275 (13.0, 185)
	Minimum	981 (10.0, 142)
	Differential limit between cylinders	98 (1.0, 14)

Cylinder number

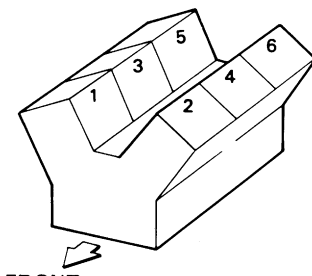

SEM713A

Valve timing
(Intake valve timing control - "OFF")

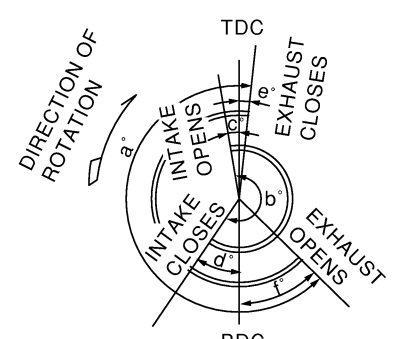

PBIC0187E

Unit: degree

a	b	c	d	e	f
244	240	-4	64	6	58

DRIVE BELT

Tension of drive belts	Auto adjustment by auto-tensioner
------------------------	-----------------------------------

INTAKE MANIFOLD COLLECTOR, INTAKE MANIFOLD AND EXHAUST MANIFOLD

SERVICE DATA AND SPECIFICATIONS (SDS)

< SERVICE DATA AND SPECIFICATIONS (SDS)

[VQ40DE]

Unit: mm (in)

Items	Limit	
Surface distortion	Intake manifold collector	0.1 (0.004)
	Intake manifold	0.1 (0.004)
	Exhaust manifold	0.3 (0.012)

SPARK PLUG

Make	NGK
Standard type*	DILFR5A-11
Gap (nominal)	1.1 mm (0.043 in)

*: Always check with the Parts Department for the latest parts information.

CAMSHAFT AND CAMSHAFT BEARING

Unit: mm (in)

Items		Standard	Limit
Camshaft journal oil clearance	No. 1	0.045 - 0.086 (0.0018 - 0.0034)	0.15 (0.0059)
	No. 2, 3, 4	0.035 - 0.076 (0.0014 - 0.0030)	
Camshaft journal length	No. 1	27.500 - 27.548 (1.0827 - 1.0846)	—
Camshaft bracket inner diameter	No. 1	26.000 - 26.021 (1.0236 - 1.0244)	—
	No. 2, 3, 4	23.500 - 23.521 (0.9252 - 0.9260)	—
Camshaft journal diameter	No. 1	25.935 - 25.955 (1.0211 - 1.0218)	—
	No. 2, 3, 4	23.445 - 23.465 (0.9230 - 0.9238)	—
Camshaft end play		0.115 - 0.188 (0.0045 - 0.0074)	0.24 (0.0094)
Camshaft cam height (A)	Intake	45.465 - 45.655 (1.7900 - 1.7974)	45.265 (1.7821)
	Exhaust	45.075 - 45.265 (1.7746 - 1.7821)	44.875 (1.7667)
Camshaft runout [TIR* ¹]		Less than 0.02 (0.0008)	0.05 (0.002)
Camshaft sprocket runout [TIR* ²]		—	0.15 (0.0059)

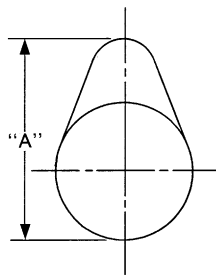

SEM671

*¹: Total indicator reading

Valve Seal

Unit: mm (in)

Items	Standard
Valve seal installed height (H)	14.3 - 14.9 (0.563 - 0.587)

Valve Lifter

Unit: mm (in)

Items	Standard
Valve lifter outer diameter	33.977 - 33.987 (1.3377 - 1.3381)

SERVICE DATA AND SPECIFICATIONS (SDS)

< SERVICE DATA AND SPECIFICATIONS (SDS)

[VQ40DE]

Valve lifter hole diameter	34.000 - 34.016 (1.3386 - 1.3392)
Valve lifter clearance	0.013 - 0.039 (0.0005 - 0.0015)

Valve Clearance

Unit: mm (in)

Items	Cold ¹	Hot ² (reference data)
Intake	0.26 - 0.34 (0.010 - 0.013)	0.304 - 0.416 (0.012 - 0.016)
Exhaust	0.29 - 0.37 (0.011 - 0.015)	0.308 - 0.432 (0.012 - 0.017)

1 : Approximately 20°C (68°F)

2 : Approximately 80°C (176°F)

Available Valve Lifter

Unit: mm (in)

Identification (stamped) mark*		Thickness
Intake	Exhaust	
788U	N788	7.88 (0.3102)
790U	N790	7.90 (0.3110)
792U	N792	7.92 (0.3118)
794U	N794	7.94 (0.3126)
796U	N796	7.96 (0.3134)
798U	N798	7.98 (0.3142)
800U	N800	8.00 (0.3150)
802U	N802	8.02 (0.3157)
804U	N804	8.04 (0.3165)
806U	N806	8.06 (0.3173)
808U	N808	8.08 (0.3181)
810U	N810	8.10 (0.3189)
812U	N812	8.12 (0.3197)
814U	N814	8.14 (0.3205)
816U	N816	8.16 (0.3213)
818U	N818	8.18 (0.3220)
820U	N820	8.20 (0.3228)
822U	N822	8.22 (0.3236)
824U	N824	8.24 (0.3244)
826U	N826	8.26 (0.3252)
828U	N828	8.28 (0.3260)
830U	N830	8.30 (0.3268)
832U	N832	8.32 (0.3276)
834U	N834	8.34 (0.3283)
836U	N836	8.36 (0.3291)
838U	—	8.38 (0.3299)

SERVICE DATA AND SPECIFICATIONS (SDS)

< SERVICE DATA AND SPECIFICATIONS (SDS)

[VQ40DE]

Identification (stamped) mark*		Thickness
Intake	Exhaust	
840U	—	8.40 (0.3307)

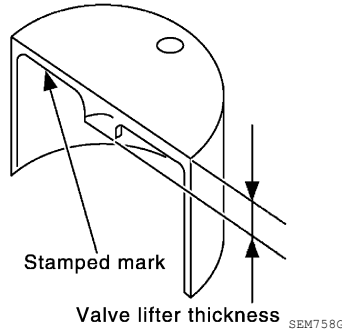

*: Always check with the Parts Department for the latest parts information.

CYLINDER HEAD

Unit: mm (in)

Items	Standard	Limit
Head surface distortion	Less than 0.03 (0.0012)	0.1 (0.004)
Normal cylinder head height (H)	126.3 - 126.5 (4.972 - 4.980)	—
Cylinder head No. 1 camshaft journal bearing length	27.360 - 27.385 (1.0772 - 1.0781)	—

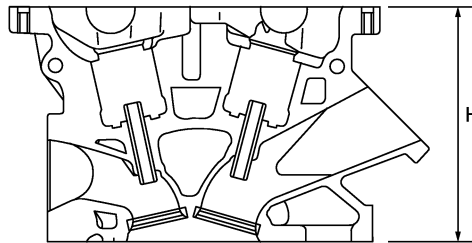

PBIC0924E

Valve Dimensions

Unit: mm (in)

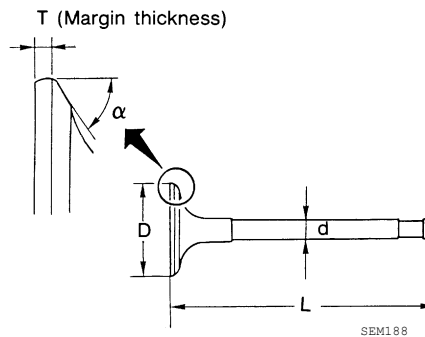

Valve head diameter (D)	Intake	37.0 - 37.3 (1.4567 - 1.4685)
	Exhaust	31.2 - 31.5 (1.228 - 1.240)
Valve length (L)	Intake	96.46 (3.7976)
	Exhaust	93.99 (3.7004)

SERVICE DATA AND SPECIFICATIONS (SDS)

< SERVICE DATA AND SPECIFICATIONS (SDS)

[VQ40DE]

Valve stem diameter (d)	Intake	5.965 - 5.980 (0.2348 - 0.2354)
	Exhaust	5.955 - 5.970 (0.2344 - 0.2350)
Valve seat angle (α)	Intake	45°15' - 45°45'
	Exhaust	
Valve margin (T)	Intake	1.1 (0.043)
	Exhaust	1.3 (0.051)

Valve Guide

Unit: mm (in)

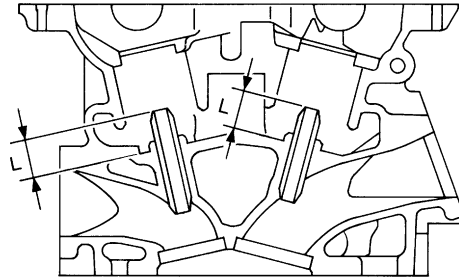

SEM950E

Items	Standard	0.2 (0.008) oversize (Service)
Valve guide	Outer diameter	10.023 - 10.034 (0.3946 - 0.3950) 10.223 - 10.234 (0.4025 - 0.4029)
	Inner diameter (Finished size)	6.000 - 6.018 (0.2362 - 0.2369)
Cylinder head valve guide hole diameter	9.975 - 9.996 (0.3927 - 0.3935)	10.175 - 10.196 (0.4006 - 0.4014)
Interference fit of valve guide	0.027 - 0.059 (0.0011 - 0.0023)	
Items	Standard	Limit
Valve guide clearance	Intake	0.020 - 0.053 (0.0008 - 0.0021) 0.08 (0.003)
	Exhaust	0.030 - 0.063 (0.0012 - 0.0025) 0.09 (0.004)
Projection length (L)	12.6 - 12.8 (0.496 - 0.504)	

Valve Seat

Unit: mm (in)

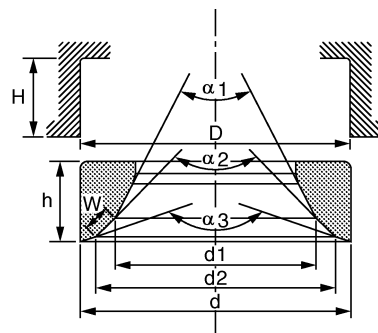

PBIC2745E

Items	Standard	Oversize [0.5 (0.020)] (Service)
Cylinder head seat recess diameter (D)	Intake	38.000 - 38.016 (1.4961 - 1.4967) 38.500 - 38.516 (1.5157 - 1.5164)
	Exhaust	32.200 - 32.216 (1.2677 - 1.2683) 32.700 - 32.716 (1.2874 - 1.2880)
Valve seat outer diameter (d)	Intake	38.097 - 38.113 (1.4999 - 1.5005) 38.597 - 38.613 (1.5196 - 1.5202)
	Exhaust	32.280 - 32.296 (1.2709 - 1.2715) 32.780 - 32.796 (1.2905 - 1.2912)
Valve seat interference fit	Intake	0.081 - 0.113 (0.0032 - 0.0044)
	Exhaust	0.064 - 0.096 (0.0025 - 0.0038)

SERVICE DATA AND SPECIFICATIONS (SDS)

< SERVICE DATA AND SPECIFICATIONS (SDS)

[VQ40DE]

Diameter (d1)* ¹	Intake	35 (1.38)	
	Exhaust	28.7 (1.130)	
Diameter (d2)* ²	Intake	36.3 - 36.8 (1.429 - 1.449)	
	Exhaust	30.3 - 30.8 (1.193 - 1.213)	
Angle α 1)	Intake	60°	
	Exhaust	60°	
Angle α 2)	Intake	88°45' - 90°15'	
	Exhaust	88°45' - 90°15'	
Angle α 3)	Intake	120°	
	Exhaust	120°	
Contacting width (W)* ³	Intake	1.0 - 1.4 (0.039-0.055)	
	Exhaust	1.2 - 1.6 (0.047-0.063)	
Height (h)	Intake	5.9 - 6.0 (0.232 - 0.236)	5.05 - 5.15 (0.1988 - 0.2028)
	Exhaust	5.9 - 6.0 (0.232 - 0.236)	4.95 - 5.05 (0.1949 - 0.1988)
Depth (H)	6.0 (0.236)		

*1: Diameter made by intersection point of conic angles (α and α 2)

*2: Diameter made by intersection point of conic angles α 2) and (α 3)

*3: Machining data

Valve Spring

Free height mm (in)	47.07 (1.8531)	
Pressure N (kg, lb) at height mm (in)	Installation	166 - 188 (16.9 - 19.2, 37 - 42) at 37.00 (1.4567)
	Valve open	373 - 421 (38.0 - 42.9, 84 - 95) at 27.20 (1.0709)
Squareness mm (in)	Limit	2.1 (0.083)

Spark Plug Tube

Unit: mm (in)

Items	Standard
Spark plug tube press-fit height (H)	38.1 - 39.1 (1.500 - 1.539)

CYLINDER BLOCK

Unit: mm (in)

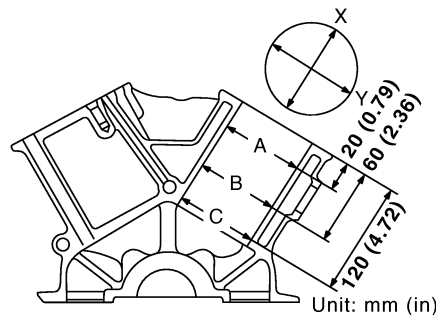

PBIC2955E

Surface flatness	Standard		Less than 0.03 (0.0012)	
	Limit		0.1 (0.004)	
Main bearing housing inner diameter	Standard		74.993 - 75.017 (2.9525 - 2.9534)	
Cylinder bore	Inner diameter	Standard*	Grade No. 1	95.500 - 95.510 (3.7598 - 3.7602)
			Grade No. 2	95.510 - 95.520 (3.7602 - 3.7606)
			Grade No. 3	95.520 - 95.530 (3.7606 - 3.7610)

SERVICE DATA AND SPECIFICATIONS (SDS)

< SERVICE DATA AND SPECIFICATIONS (SDS)

[VQ40DE]

Out-of-round [Difference between (X) and (Y)]	Limit	0.015 (0.0006)
Taper [Difference between (A) and (C)]		0.01 (0.0004)
Main bearing housing inner diameter (Without bearing) grades*	Grade No. A	74.993 - 74.994 (2.9525 - 2.9525)
	Grade No. B	74.994 - 74.995 (2.9525 - 2.9526)
	Grade No. C	74.995 - 74.996 (2.9526 - 2.9526)
	Grade No. D	74.996 - 74.997 (2.9526 - 2.9526)
	Grade No. E	74.997 - 74.998 (2.9526 - 2.9527)
	Grade No. F	74.998 - 74.999 (2.9527 - 2.9527)
	Grade No. G	74.999 - 75.000 (2.9527 - 2.9528)
	Grade No. H	75.000 - 75.001 (2.9528 - 2.9528)
	Grade No. J	75.001 - 75.002 (2.9528 - 2.9528)
	Grade No. K	75.002 - 75.003 (2.9528 - 2.9529)
	Grade No. L	75.003 - 75.004 (2.9529 - 2.9529)
	Grade No. M	75.004 - 75.005 (2.9529 - 2.9529)
	Grade No. N	75.005 - 75.006 (2.9529 - 2.9530)
	Grade No. P	75.006 - 75.007 (2.9530 - 2.9530)
	Grade No. R	75.007 - 75.008 (2.9530 - 2.9531)
	Grade No. S	75.008 - 75.009 (2.9530 - 2.9531)
	Grade No. T	75.009 - 75.010 (2.9531 - 2.9531)
Grade No. U	75.010 - 75.011 (2.9531 - 2.9532)	
Grade No. V	75.011 - 75.012 (2.9532 - 2.9532)	
Grade No. W	75.012 - 75.013 (2.9532 - 2.9533)	
Grade No. X	75.013 - 75.014 (2.9533 - 2.9533)	
Grade No. Y	75.014 - 75.015 (2.9533 - 2.9533)	
Grade No. 4	75.015 - 75.016 (2.9533 - 2.9534)	
Grade No. 7	75.016 - 75.017 (2.9534 - 2.9534)	
Difference in inner diameter between cylinders	Standard	Less than 0.03 (0.0012)

* : Always check with the Parts Department for the latest parts information.

PISTON, PISTON RING AND PISTON PIN

Available Piston

Unit: mm (in)

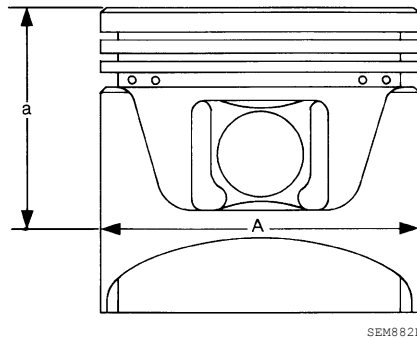

Items	Grade*	Standard	—
Piston skirt diameter (A)	Grade No. 1	95.480 - 95.490 (3.7590 - 3.7594)	—
	Grade No. 2	95.490 - 95.500 (3.7594 - 3.7598)	—
	Grade No. 3	95.500 - 95.510 (3.7598 - 3.7602)	—
Items		Standard	Limit
(a) dimension		43.03 (1.6941)	—
Piston pin hole diameter	Grade No. 0	21.993 - 21.999 (0.8659 - 0.8661)	—
	Grade No. 1	21.999 - 22.005 (0.8661 - 0.8663)	—
Piston to cylinder bore clearance		0.010 - 0.030 (0.0004 - 0.0012)	0.08 (0.0031)

*: Always check with the Parts Department for the latest parts information.

Piston Ring

SERVICE DATA AND SPECIFICATIONS (SDS)

< SERVICE DATA AND SPECIFICATIONS (SDS)

[VQ40DE]

Unit: mm (in)

Items		Standard	Limit
Side clearance	Top	0.045 - 0.080 (0.0018 - 0.0031)	0.11 (0.0043)
	2nd	0.030 - 0.070 (0.0012 - 0.0028)	0.10 (0.0039)
	Oil ring	0.065 - 0.135 (0.0026 - 0.0053)	—
End gap	Top	0.23 - 0.33 (0.0091 - 0.0130)	0.56 (0.0220)
	2nd	0.33 - 0.48 (0.0130 - 0.0189)	0.68 (0.0268)
	Oil (rail ring)	0.20 - 0.50 (0.0079 - 0.0197)	0.85 (0.0335)

Piston Pin

Unit: mm (in)

Items	Grade*	Standard	Limit
Piston pin outer diameter	Grade No. 0	21.989 - 21.995 (0.8657 - 0.8659)	—
	Grade No. 1	21.995 - 22.001 (0.8659 - 0.8662)	—
Piston to piston pin oil clearance		0.002 - 0.006 (0.0001 - 0.0002)	—
Connecting rod bushing oil clearance		0.005 - 0.017 (0.0002 - 0.0007)	0.030 (0.0012)

*: Always check with the Parts Department for the latest parts information.

CONNECTING ROD

Unit: mm (in)

Items	Grade ¹	Standard	Limit
Center distance		165.82 - 165.92 (6.5283 - 6.5323)	—
Bend [per 100 (3.94)]		—	0.15 (0.0059)
Torsion [per 100 (3.94)]		—	0.30 (0.0118)
Connecting rod bushing inner diameter ²	Grade No. 0	22.000 - 22.006 (0.8661 - 0.8664)	—
	Grade No. 1	22.006 - 22.012 (0.8664 - 0.8666)	—
Connecting rod big end diameter (Without bearing)		57.000 - 57.013 (2.2441 - 2.2446)	—
Side clearance		0.20 - 0.35 (0.0079 - 0.0138)	40 (0.0157)

¹: Always check with the Parts Department for the latest parts information.

²: After installing in connecting rod

CRANKSHAFT

Unit: mm (in)

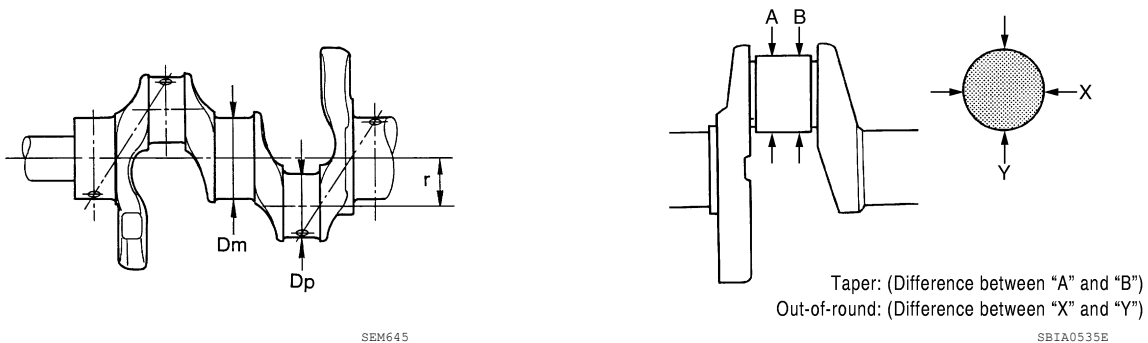

SERVICE DATA AND SPECIFICATIONS (SDS)

< SERVICE DATA AND SPECIFICATIONS (SDS)

[VQ40DE]

		Grade ¹	Dimension
Main journal diameter. (Dm) grade	Standard	Grade No. A	69.975 - 69.974 (2.7549 - 2.7549)
		Grade No. B	69.974 - 69.973 (2.7549 - 2.7548)
		Grade No. C	69.973 - 69.972 (2.7548 - 2.7548)
		Grade No. D	69.972 - 69.971 (2.7548 - 2.7548)
		Grade No. E	69.971 - 69.970 (2.7548 - 2.7547)
		Grade No. F	69.970 - 69.969 (2.7547 - 2.7547)
		Grade No. G	69.969 - 69.968 (2.7547 - 2.7546)
		Grade No. H	69.968 - 69.967 (2.7546 - 2.7546)
		Grade No. J	69.967 - 69.966 (2.7546 - 2.7546)
		Grade No. K	69.966 - 69.965 (2.7546 - 2.7545)
		Grade No. L	69.965 - 69.964 (2.7545 - 2.7545)
		Grade No. M	69.964 - 69.963 (2.7545 - 2.7544)
		Grade No. N	69.963 - 69.962 (2.7544 - 2.7544)
		Grade No. P	69.962 - 69.961 (2.7544 - 2.7544)
		Grade No. R	69.961 - 69.960 (2.7544 - 2.7543)
		Grade No. S	69.960 - 69.959 (2.7543 - 2.7543)
		Grade No. T	69.959 - 69.958 (2.7543 - 2.7542)
		Grade No. U	69.958 - 69.957 (2.7542 - 2.7542)
		Grade No. V	69.957 - 69.956 (2.7542 - 2.7542)
		Grade No. W	69.956 - 69.955 (2.7542 - 2.7541)
Grade No. X	69.955 - 69.954 (2.7541 - 2.7541)		
Grade No. Y	69.954 - 69.953 (2.7541 - 2.7540)		
Grade No. 4	69.953 - 69.952 (2.7540 - 2.7540)		
Grade No. 7	69.952 - 69.951 (2.7540 - 2.7540)		
Pin journal diameter. (Dp) grade	Standard	Grade No. 0	53.968 - 53.974 (2.1247 - 2.1250)
		Grade No. 1	53.962 - 53.968 (2.1245 - 2.1247)
		Grade No. 2	53.956 - 53.962 (2.1242 - 2.1245)
Center distance (r)			45.96 - 46.04 (1.8094 - 1.8126)
Taper [Difference between (A) and (B)]	Limit		0.002 (0.0001)
Out-of-round [Difference between (X) and (Y)]			0.002 (0.0001)
Crankshaft runout [TIR ²]	Standard		Less than 0.05 (0.002)
	Limit		0.10 (0.0039)
Crankshaft end play	Standard		0.10 - 0.25 (0.0039 - 0.0098)
	Limit		0.30 (0.0118)

¹: Always check with the Parts Department for the latest parts information.

²: Total indicator reading

MAIN BEARING

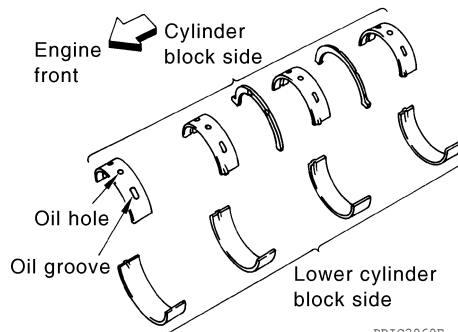

PBIC2969E

Grade number*	UPR/LWR	Thickness	mm (in)	Width	mm (in)	Identification color	Remarks

SERVICE DATA AND SPECIFICATIONS (SDS)

< SERVICE DATA AND SPECIFICATIONS (SDS)

[VQ40DE]

0	—	2.500 - 2.503 (0.0984 - 0.0985)	19.9 - 20.1 (0.783 - 0.791)	Black	Grade is the same for upper and lower bearings.	A			
1	—	2.503 - 2.506 (0.0985 - 0.0987)		Brown			EM		
2	—	2.506 - 2.509 (0.0987 - 0.0988)		Green				C	
3	—	2.509 - 2.512 (0.0988 - 0.0989)		Yellow					
4	—	2.512 - 2.515 (0.0989 - 0.0990)		Blue					
5	—	2.515 - 2.518 (0.0990 - 0.0991)		Pink					
6	—	2.518 - 2.521 (0.0991 - 0.0993)		Purple					
7	—	2.521 - 2.524 (0.0993 - 0.0994)		White	D				
01	UPR	2.503 - 2.506 (0.0985 - 0.0987)		Brown		Grade is different for upper and lower bearings.	E		
	LWR	2.500 - 2.503 (0.0984 - 0.0985)		Black					
12	UPR	2.506 - 2.509 (0.0987 - 0.0988)		Green				F	
	LWR	2.503 - 2.506 (0.0985 - 0.0987)		Brown					
23	UPR	2.509 - 2.512 (0.0988 - 0.0989)		Yellow					G
	LWR	2.506 - 2.509 (0.0987 - 0.0988)		Green					
34	UPR	2.512 - 2.515 (0.0989 - 0.0990)	Blue	H					
	LWR	2.509 - 2.512 (0.0988 - 0.0989)	Yellow						
45	UPR	2.515 - 2.518 (0.0990 - 0.0991)	Pink		I				
	LWR	2.512 - 2.515 (0.0989 - 0.0990)	Blue						
56	UPR	2.518 - 2.521 (0.0991 - 0.0993)	Purple			J			
	LWR	2.515 - 2.518 (0.0990 - 0.0991)	Pink						
67	UPR	2.521 - 2.524 (0.0993 - 0.0994)	White				K		
	LWR	2.518 - 2.521 (0.0991 - 0.0993)	Purple						

*: Always check with the Parts Department for the latest parts information.

Undersize

Unit: mm (in)

Items	Thickness	Main journal diameter
0.25 (0.0098)	2.633 - 2.641 (0.1037 - 0.1040)	Grind so that bearing clearance is the specified value.

Main Bearing Oil Clearance

Unit: mm (in)

Items	Standard	Limit
Main bearing oil clearance	0.035 - 0.045 (0.0014 - 0.0018)*	0.065 (0.0026)

*: Actual clearance

CONNECTING ROD BEARING

Grade number*	Thickness mm (in)	Identification color (mark)
0	1.500 - 1.503 (0.0591 - 0.0592)	Black
1	1.503 - 1.506 (0.0592 - 0.0593)	Brown
2	1.506 - 1.509 (0.0593 - 0.0594)	Green

*: Always check with the Parts Department for the latest parts information.

Undersize

Unit: mm (in)

Items	Thickness	Crank pin journal diameter
0.25 (0.0098)	1.626 - 1.634 (0.0640 - 0.0643)	Grind so that bearing clearance is the specified value.

Connecting Rod Bearing Oil Clearance

SERVICE DATA AND SPECIFICATIONS (SDS)

< SERVICE DATA AND SPECIFICATIONS (SDS)

[VQ40DE]

Unit: mm (in)

Items	Standard	Limit
Connecting rod bearing oil clearance	0.034 - 0.059 (0.0013 - 0.0023)*	0.070 (0.0028)

*: Actual clearance