

SECTION **INL**

INTERIOR LIGHTING SYSTEM

A
B
C
D
E
F
G
H
I
J
K
INL
M
N
O
P

CONTENTS

<p>BASIC INSPECTION 3</p> <p>DIAGNOSIS AND REPAIR WORKFLOW 3</p> <p style="padding-left: 20px;">Work Flow3</p> <p>SYSTEM DESCRIPTION 6</p> <p>INTERIOR ROOM LAMP CONTROL SYSTEM</p> <p style="text-align: right; padding-right: 20px;">..... 6</p> <p style="padding-left: 20px;">System Diagram6</p> <p style="padding-left: 20px;">System Description6</p> <p style="padding-left: 20px;">Component Parts Location7</p> <p style="padding-left: 20px;">Component Description8</p> <p>ILLUMINATION CONTROL SYSTEM 9</p> <p style="padding-left: 20px;">System Diagram9</p> <p style="padding-left: 20px;">System Description9</p> <p style="padding-left: 20px;">Component Parts Location10</p> <p style="padding-left: 20px;">Component Description10</p> <p>DIAGNOSIS SYSTEM (BCM)11</p> <p>COMMON ITEM11</p> <p style="padding-left: 20px;">COMMON ITEM : CONSULT Function (BCM - COMMON ITEM)11</p> <p>INT LAMP11</p> <p style="padding-left: 20px;">INT LAMP : CONSULT Function (BCM - INT LAMP)12</p> <p>BATTERY SAVER12</p> <p style="padding-left: 20px;">BATTERY SAVER : CONSULT Function (BCM - BATTERY SAVER)13</p> <p>DTC/CIRCUIT DIAGNOSIS14</p> <p>POWER SUPPLY AND GROUND CIRCUIT14</p> <p>BCM14</p> <p style="padding-left: 20px;">BCM : Diagnosis Procedure14</p> <p>BATTERY SAVER OUTPUT/POWER SUPPLY CIRCUIT16</p>	<p style="padding-left: 20px;">Description16</p> <p style="padding-left: 20px;">Component Function Check16</p> <p style="padding-left: 20px;">Diagnosis Procedure16</p> <p>INTERIOR ROOM LAMP CONTROL CIRCUIT18</p> <p style="text-align: right; padding-right: 20px;">.....18</p> <p style="padding-left: 20px;">Description18</p> <p style="padding-left: 20px;">Component Function Check18</p> <p style="padding-left: 20px;">Diagnosis Procedure18</p> <p>CARGO LAMP CONTROL CIRCUIT20</p> <p style="padding-left: 20px;">Description20</p> <p style="padding-left: 20px;">Component Function Check20</p> <p style="padding-left: 20px;">Diagnosis Procedure20</p> <p>IGNITION KEYHOLE ILLUMINATION CONTROL CIRCUIT22</p> <p style="padding-left: 20px;">Description22</p> <p style="padding-left: 20px;">Component Function Check22</p> <p style="padding-left: 20px;">Diagnosis Procedure22</p> <p>ECU DIAGNOSIS INFORMATION24</p> <p>BCM (BODY CONTROL MODULE)24</p> <p style="padding-left: 20px;">Reference Value24</p> <p style="padding-left: 20px;">Terminal Layout27</p> <p style="padding-left: 20px;">Physical Values27</p> <p style="padding-left: 20px;">Fail Safe32</p> <p style="padding-left: 20px;">DTC Inspection Priority Chart32</p> <p style="padding-left: 20px;">DTC Index33</p> <p>WIRING DIAGRAM35</p> <p>INTERIOR ROOM LAMP35</p> <p style="padding-left: 20px;">Wiring Diagram35</p> <p>ILLUMINATION46</p> <p style="padding-left: 20px;">Wiring Diagram46</p> <p>SYMPTOM DIAGNOSIS56</p> <p>INTERIOR LIGHTING SYSTEM SYMPTOMS ...56</p>
---	---

Symptom Table	56	REMOVAL AND INSTALLATION	59
PRECAUTION	57	INTERIOR ROOM LAMP	59
PRECAUTIONS	57	Removal and Installation	59
Precaution for Supplemental Restraint System (SRS) "AIR BAG" and "SEAT BELT PRE-TEN- SIONER"	57	ILLUMINATION	62
Precaution for Work	57	Removal and Installation	62
PREPARATION	58	SERVICE DATA AND SPECIFICATIONS (SDS)	64
PREPARATION	58	BULB SPECIFICATIONS	64
Special Service Tool	58	Bulb Specifications	64

DIAGNOSIS AND REPAIR WORKFLOW

< BASIC INSPECTION >

BASIC INSPECTION

DIAGNOSIS AND REPAIR WORKFLOW

Work Flow

INFOID:000000011068469

OVERALL SEQUENCE

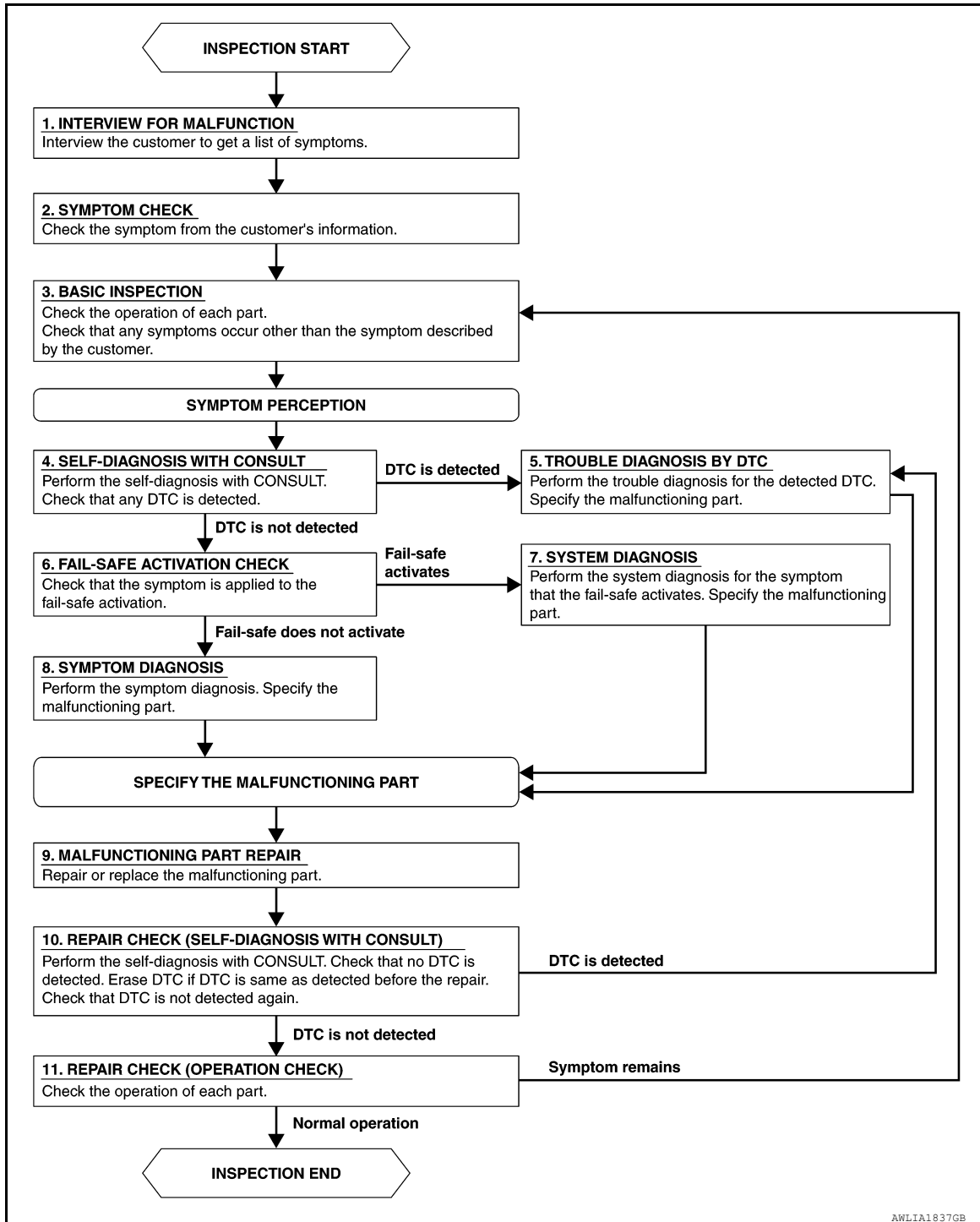

AWLIA1837GB

A
B
C
D
E
F
G
H
I
J
K
INL
M
N
O
P

DIAGNOSIS AND REPAIR WORKFLOW

< BASIC INSPECTION >

DETAILED FLOW

1. INTERVIEW FOR MALFUNCTION

Find out what the customer's concerns are.

>> GO TO 2.

2. SYMPTOM CHECK

Verify the symptom from the customer's information.

>> GO TO 3.

3. BASIC INSPECTION

Check the operation of each part. Check that any concerns occur other than those mentioned in the customer interview.

>> GO TO 4.

4. SELF-DIAGNOSIS WITH CONSULT

Perform the self-diagnosis with CONSULT. Check that any DTC is detected.

Is any DTC detected?

YES >> GO TO 5.

NO >> GO TO 6.

5. TROUBLE DIAGNOSIS BY DTC

Perform the trouble diagnosis for the detected DTC. Specify the malfunctioning part.

>> GO TO 9.

6. FAIL-SAFE ACTIVATION CHECK

Determine if the customer's concern is related to fail-safe activation.

Does the fail-safe activate?

YES >> GO TO 7.

NO >> GO TO 8.

7. SYSTEM DIAGNOSIS

Perform the system diagnosis for the system in which the fail-safe activates. Specify the malfunctioning part.

>> GO TO 9.

8. SYMPTOM DIAGNOSIS

Perform the symptom diagnosis. Specify the malfunctioning part.

>> GO TO 9.

9. MALFUNCTION PART REPAIR

Repair or replace the malfunctioning part.

>> GO TO 10.

10. REPAIR CHECK (SELF-DIAGNOSIS WITH CONSULT)

Perform the self-diagnosis with CONSULT. Verify that no DTCs are detected. Erase all DTCs detected prior to the repair. Verify that DTC is not detected again.

Is any DTC detected?

YES >> GO TO 5.

DIAGNOSIS AND REPAIR WORKFLOW

< BASIC INSPECTION >

NO >> GO TO 11.

11. REPAIR CHECK (OPERATION CHECK)

Check the operation of each part.

Does it operate normally?

YES >> Inspection End.

NO >> GO TO 3.

A

B

C

D

E

F

G

H

I

J

K

INL

M

N

O

P

INTERIOR ROOM LAMP CONTROL SYSTEM

< SYSTEM DESCRIPTION >

SYSTEM DESCRIPTION

INTERIOR ROOM LAMP CONTROL SYSTEM

System Diagram

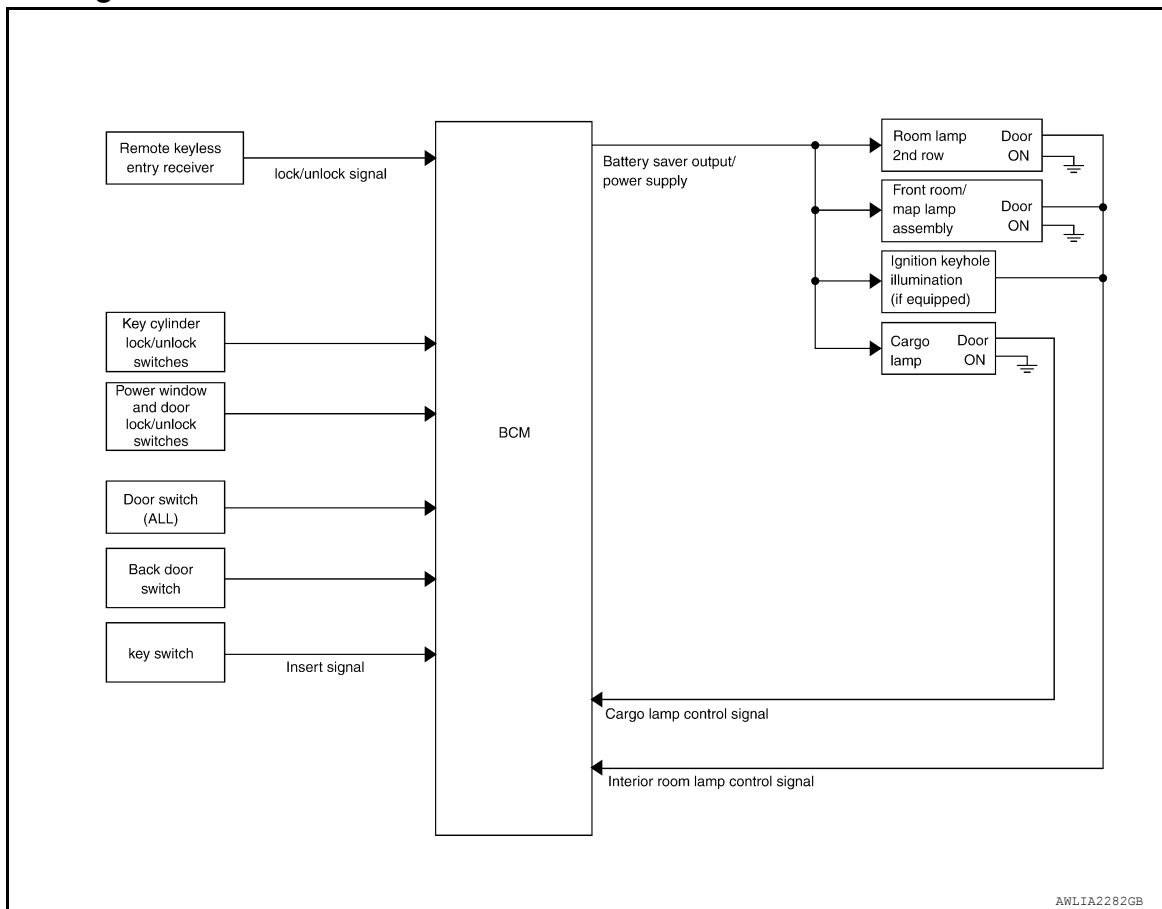

System Description

INFOID:000000011068471

OUTLINE

- Front room/map lamp and room lamp 2nd row are controlled by the interior room lamp timer control function of the BCM.

- Cargo lamp is controlled by the cargo lamp control function of the BCM.

The timer control functions of the BCM activate based on inputs from the remote keyless entry receiver, the key cylinder lock/unlock switches, the door switches, the key switch and the power window and door lock/unlock switches.

ROOM LAMP TIMER OPERATION

When the interior room lamp switch is in the DOOR position, the BCM begins timer control (maximum 30 seconds) for interior room lamp ON/OFF and when all of the following conditions are met:

- When the front door LH is unlocked [with main power window and door lock/unlock switch, or front door lock assembly LH (key cylinder switch)].
- When a door opens → closes.

Timer control is cancelled under the following conditions:

- When the front door LH is locked [with main power window and door lock/unlock switch, or front door lock assembly LH (key cylinder switch)].
- A door is opened (door switch turns ON).
- The ignition switch is placed the ON position.

Interior lamp operational settings can be changed with the CONSULT.

INTERIOR LAMP BATTERY SAVER CONTROL

INTERIOR ROOM LAMP CONTROL SYSTEM

< SYSTEM DESCRIPTION >

If an interior lamp is left ON and does not turn OFF even when the doors are closed, the BCM turns off power to the interior lamps automatically to save the battery 10 minutes after the ignition switch is turned OFF. The BCM controls power and ground to all interior lamps.

After the battery saver system turns the lamps OFF, the lamps will illuminate again when the following conditions are met:

- A signal is received from a main power window and door lock/unlock switch, or when the front door lock assembly LH (key cylinder switch) is locked or unlocked.
- A door is opened or closed.

The interior lamp battery saver control time period can be changed with the CONSULT.

Component Parts Location

INFOID:000000011068472

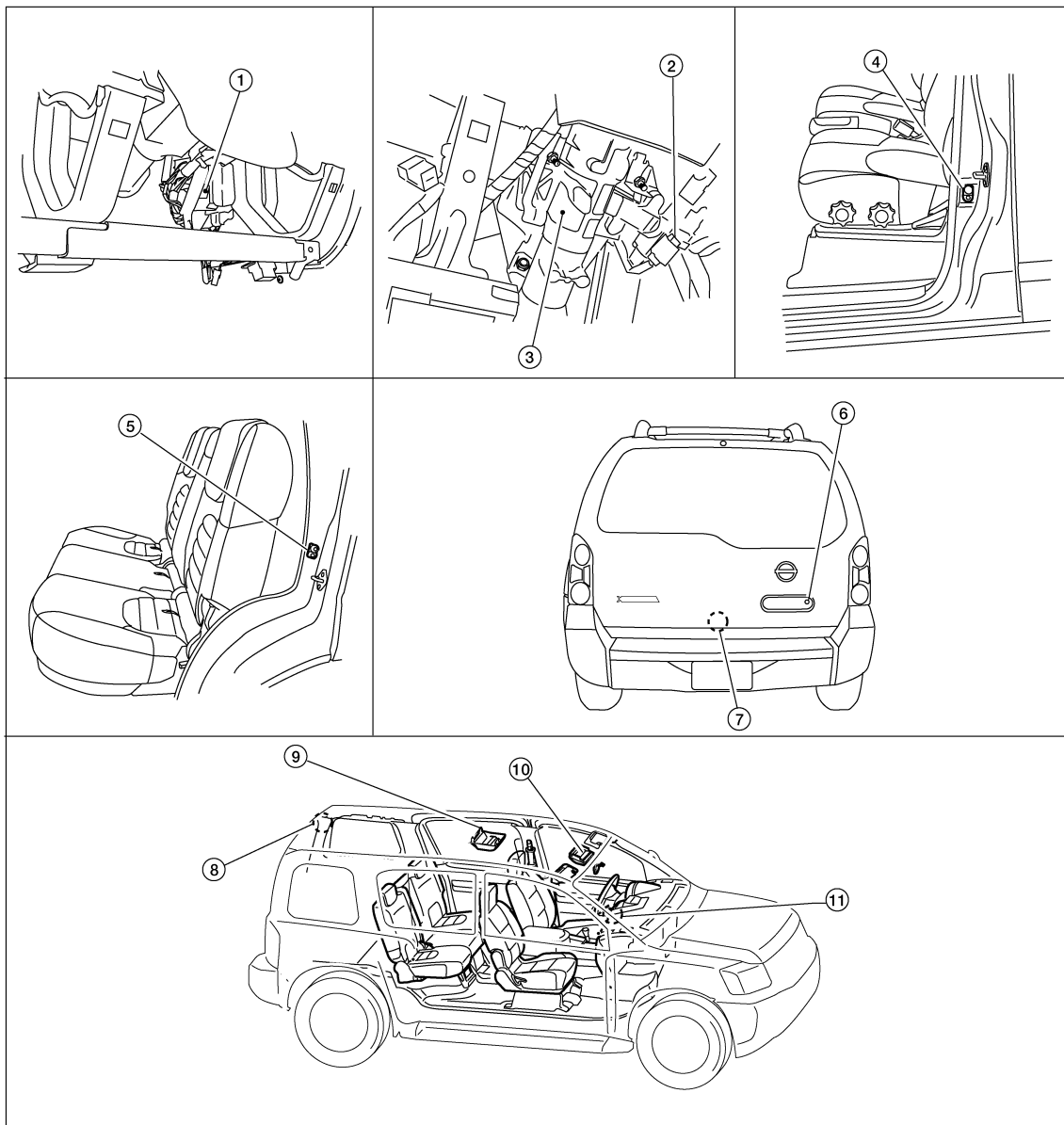

- | | | |
|--|--|---------------------------------------|
| 1. BCM M18, M19, M20 (view with lower instrument panel LH removed) | 2. Key switch M27 | 3. Steering column assembly |
| 4. Front door switch
LH B8
RH B108 | 5. Rear door switch
LH B18
RH B116 | 6. Back door key cylinder switch D505 |

INTERIOR ROOM LAMP CONTROL SYSTEM

< SYSTEM DESCRIPTION >

- | | | |
|-------------------------------------|--|--------------------------|
| 7. Back door switch D502 | 8. Cargo lamp R11 | 9. Room lamp 2nd row R12 |
| 10. Front room/map lamp assembly R9 | 11. Ignition keyhole illumination M150 (if equipped) | |

Component Description

INFOID:000000011068473

Part name	Description
BCM	Provides power and ground and controls timer functions for the interior room lamps and cargo lamp.
Key switch	Provides key in ignition status to the BCM.
Door switches	Provides door OPEN/CLOSED status to the BCM.
Back door switch	Provides back door OPEN/CLOSED status to the BCM.
Main power window and door lock/unlock switch	Provides door lock/unlock position switch status to the BCM.
Power window and door lock/unlock switch RH	
Front door lock assembly LH (key cylinder switch)	Provides door lock/unlock status to the BCM.
Back door key cylinder switch	

ILLUMINATION CONTROL SYSTEM

< SYSTEM DESCRIPTION >

ILLUMINATION CONTROL SYSTEM

System Diagram

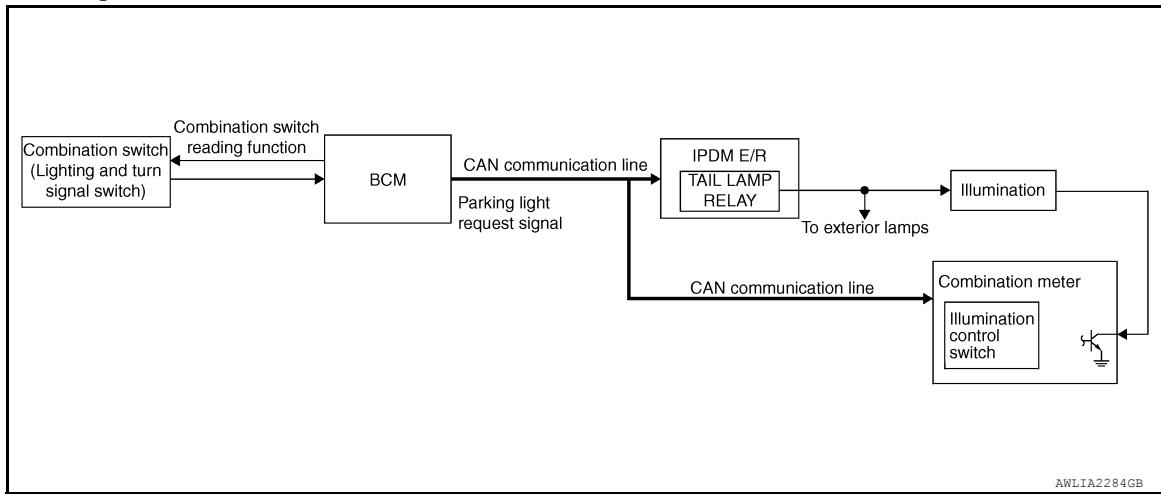

System Description

INFOID:000000011068475

The illumination lamps operation is dependent upon the position of the combination switch (lighting and turn signal switch). When the combination switch (lighting and turn signal switch) is placed in the 1ST or 2ND position the BCM (body control module) receives input requesting the parking lamps to illuminate. This input is communicated to the IPDM E/R (intelligent power distribution module engine room) via the CAN communication lines. The CPU (central processing unit) of the IPDM E/R controls the tail lamp relay coil. When energized, this relay directs power to the parking and illumination lamps, which then illuminate.

BATTERY SAVER CONTROL

When the combination switch (lighting and turn signal switch) is in the 1ST or 2ND position and the ignition switch is turned from ON or ACC to OFF, the battery saver control feature is activated. Under this condition, the illumination lamps remain illuminated for 10 minutes unless the combination switch (lighting and turn signal switch) position is changed. If the combination switch (lighting and turn signal switch) position is changed, then the illumination lamps are turned off after a 30 second delay. When the combination switch (lighting and turn signal switch) is turned from OFF to 1ST or 2ND position after illumination lamps have been turned off by the battery saver control, the illumination lamps illuminate again.

A
B
C
D
E
F
G
H
I
J
K
M
N
O
P

INL

ILLUMINATION CONTROL SYSTEM

< SYSTEM DESCRIPTION >

Component Parts Location

INFOID:000000011068476

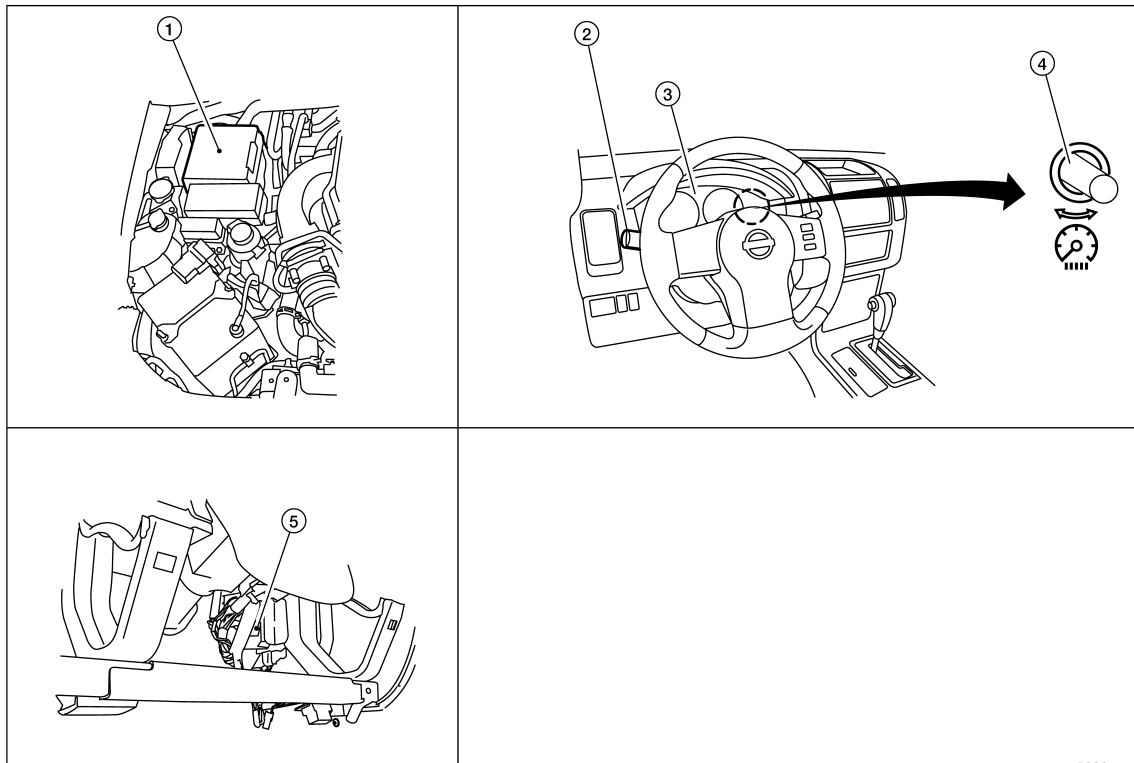

WKIA5029E

1. IPDM E/R E122, E124
2. Combination switch (lighting and turn signal switch) M28
3. Combination meter M24
4. Illumination control switch (built into combination meter)
5. BCM M18, M20 (view with lower instrument panel LH removed)

Component Description

INFOID:000000011068477

Part name	Description
BCM	The BCM monitors the lighting switch position with the combination switch reading function. The BCM requests, via CAN communication, that the IPDM E/R activate the tail lamp relay.
IPDM E/R	The IPDM E/R activates the tail lamp relay based on inputs received from the BCM via the CAN communication network.
Combination meter (illumination control switch)	The illumination control switch is a part of the combination meter. The combination meter controls illumination intensity by varying ground to the illumination lamps based on the illumination control switch position.
Combination switch (lighting and turn signal switch)	The combination switch (lighting and turn signal switch) provides input to the BCM about the lighting switch position.

DIAGNOSIS SYSTEM (BCM)

< SYSTEM DESCRIPTION >

DIAGNOSIS SYSTEM (BCM)

COMMON ITEM

COMMON ITEM : CONSULT Function (BCM - COMMON ITEM)

INFOID:0000000011376543

APPLICATION ITEM

CONSULT performs the following functions via CAN communication with BCM.

Direct Diagnostic Mode	Description
ECU Identification	The BCM part number is displayed.
Self Diagnostic Result	The BCM self diagnostic results are displayed.
Data Monitor	The BCM input/output data is displayed in real time.
Active Test	The BCM activates outputs to test components.
Work support	The settings for BCM functions can be changed.
Configuration	<ul style="list-style-type: none"> • The vehicle specification can be read and saved. • The vehicle specification can be written when replacing BCM.
CAN Diag Support Mntr	The result of transmit/receive diagnosis of CAN communication is displayed.

SYSTEM APPLICATION

BCM can perform the following functions.

System	Sub System	Direct Diagnostic Mode						
		ECU Identification	Self Diagnostic Result	Data Monitor	Active Test	Work support	Configuration	CAN Diag Support Mntr
Door lock	DOOR LOCK			x	x	x		
Rear window defogger	REAR DEFOGGER			x	x			
Warning chime	BUZZER			x	x			
Interior room lamp timer	INT LAMP			x	x	x		
Remote keyless entry system	MULTI REMOTE ENT			x	x	x		
Exterior lamp	HEAD LAMP			x	x	x		
Wiper and washer	WIPER			x	x	x		
Turn signal and hazard warning lamps	FLASHER			x	x			
Air conditioner	AIR CONDITIONER			x				
Combination switch	COMB SW			x				
BCM	BCM	x	x			x	x	x
Immobilizer	IMMU		x	x	x			
Interior room lamp battery saver	BATTERY SAVER			x	x	x		
Back door open	TRUNK			x	x			
Vehicle security system	THEFT ALM			x	x	x		
RAP system	RETAINED PWR			x	x	x		
Signal buffer system	SIGNAL BUFFER			x	x			
TPMS	AIR PRESSURE MONITOR		x	x	x	x		
Panic alarm system	PANIC ALARM				x			

INT LAMP

DIAGNOSIS SYSTEM (BCM)

< SYSTEM DESCRIPTION >

INT LAMP : CONSULT Function (BCM - INT LAMP)

INFOID:000000011376544

DATA MONITOR

Monitor Item [Unit]	Description
IGN ON SW [On/Off]	Indicates condition of ignition switch ON position.
KEY ON SW [On/Off]	Indicates condition of key switch.
DOOR SW-DR [On/Off]	Indicates condition of front door switch LH.
DOOR SW-AS [On/Off]	Indicates condition of front door switch RH.
DOOR SW-RR [On/Off]	Indicates condition of rear door switch RH.
DOOR SW-RL [On/Off]	Indicates condition of rear door switch LH.
BACK DOOR SW [On/Off]	Indicates condition of back door switch.
KEY CYL LK-SW [On/Off]	Indicates condition of lock signal from door key cylinder switch.
KEY CYL UN-SW [On/Off]	Indicates condition of unlock signal from door key cylinder switch.
CDL LOCK SW [On/Off]	Indicates condition of lock signal from door lock and unlock switch.
CDL UNLOCK SW [On/Off]	Indicates condition of unlock signal from door lock and unlock switch.
KEYLESS LOCK [On/Off]	Indicates condition of lock signal from keyfob.
KEYLESS UNLOCK [On/Off]	Indicates condition of unlock signal from keyfob.

ACTIVE TEST

Test Item	Description
IGN ILLUM	This test is able to check ignition keyhole illumination operation [Off/On].
INT LAMP	This test is able to check interior room lamp operation [Off/On].
LUGGAGE LAMP TEST	This test is able to check cargo lamp operation [Off/On].

WORK SUPPORT

Support Item	Setting	Description
SET I/L D-UNLCK INTCON	Off	Interior room lamp timer function OFF.
	On*	Interior room lamp timer function ON.
ROOM LAMP ON TIME SET	MODE7	0 sec.
	MODE6	5 sec.
	MODE5	4 sec.
	MODE4	3 sec.
	MODE3	2 sec.
	MODE2*	1 sec.
	MODE1	0.5 sec.
ROOM LAMP OFF TIME SET	MODE7	0 sec.
	MODE6	5 sec.
	MODE5	4 sec.
	MODE4	3 sec.
	MODE3	2 sec.
	MODE2*	1 sec.
	MODE1	0.5 sec.

* : Initial setting

BATTERY SAVER

DIAGNOSIS SYSTEM (BCM)

< SYSTEM DESCRIPTION >

BATTERY SAVER : CONSULT Function (BCM - BATTERY SAVER)

INFOID:0000000011376545

DATA MONITOR

Monitor Item [Unit]	Description
IGN ON SW [On/Off]	Indicates condition of ignition switch ON position.
KEY ON SW [On/Off]	Indicates condition of key switch.
DOOR SW-DR [On/Off]	Indicates condition of front door switch LH.
DOOR SW-AS [On/Off]	Indicates condition of front door switch RH.
DOOR SW-RR [On/Off]	Indicates condition of rear door switch RH.
DOOR SW-RL [On/Off]	Indicates condition of rear door switch LH.
BACK DOOR SW [On/Off]	Indicates condition of back door switch.
KEY CYL LK SW [On/Off]	Indicates condition of lock signal from door key cylinder switch.
KEY CYL UN SW [On/Off]	Indicates condition of unlock signal from door key cylinder switch.
CDL LOCK SW [On/Off]	Indicates condition of lock signal from door lock and unlock switch.
CDL UNLOCK SW [On/Off]	Indicates condition of unlock signal from door lock and unlock switch.
KEYLESS LOCK [On/Off]	Indicates condition of lock signal from keyfob.
KEYLESS UNLOCK [On/Off]	Indicates condition of unlock signal from keyfob.

ACTIVE TEST

Test item	Description
BATTERY SAVER	This test is able to check battery saver operation [Off/On].

WORK SUPPORT

Support Item	Setting		Description
ROOM LAMP TIMER SET	MODE2	60 min	Sets the interior room lamp battery saver timer operating time.
	MODE1*	10 min	

*: Initial setting

A
B
C
D
E
F
G
H
I
J
K

INL

POWER SUPPLY AND GROUND CIRCUIT

< DTC/CIRCUIT DIAGNOSIS >

DTC/CIRCUIT DIAGNOSIS

POWER SUPPLY AND GROUND CIRCUIT

BCM

BCM : Diagnosis Procedure

INFOID:000000011376546

Regarding Wiring Diagram information, refer to [BCS-45, "Wiring Diagram"](#).

1. CHECK FUSES AND FUSIBLE LINK

Check that the following fuses and fusible link are not blown.

Terminal No.	Signal name	Fuses and fusible link No.
57	Battery power supply	21 (10A)
70		G (50A)
11	Ignition ACC or ON	4 (10A)
38	Ignition ON or START	1 (10A)

Is the fuse blown?

YES >> Replace the blown fuse or fusible link after repairing the affected circuit.

NO >> GO TO 2.

2. CHECK POWER SUPPLY CIRCUIT

- Turn ignition switch OFF.
- Disconnect BCM.
- Check voltage between BCM harness connector and ground.

Connector	Terminals		Power source	Condition	Voltage (V) (Approx.)
	(+)	(-)			
M18	11	Ground	ACC power supply	Ignition switch ACC or ON	Battery voltage
	38	Ground	Ignition power supply	Ignition switch ON or START	Battery voltage
M20	57	Ground	Battery power supply	Ignition switch OFF	Battery voltage
	70	Ground	Battery power supply	Ignition switch OFF	Battery voltage

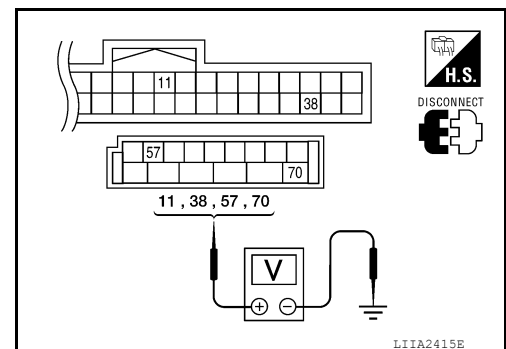

Is the measurement value normal?

YES >> GO TO 3.

NO >> Repair or replace harness.

3. CHECK GROUND CIRCUIT

POWER SUPPLY AND GROUND CIRCUIT

< DTC/CIRCUIT DIAGNOSIS >

Check continuity between BCM harness connector and ground.

BCM		Ground	Continuity
Connector	Terminal		
M20	67		Yes

Does continuity exist?

- YES >> Inspection End.
- NO >> Repair or replace harness.

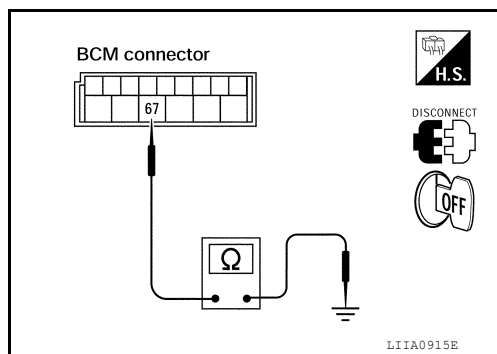

A
B
C
D
E
F
G
H
I
J
K
L
M
N
O
P

INL

BATTERY SAVER OUTPUT/POWER SUPPLY CIRCUIT

< DTC/CIRCUIT DIAGNOSIS >

BATTERY SAVER OUTPUT/POWER SUPPLY CIRCUIT

Description

INFOID:000000011068482

Provides the battery saver output/power supply. Also cuts the power supply when the interior room lamp battery saver is activating.

Component Function Check

INFOID:000000011068483

1. CHECK BATTERY SAVER OUTPUT/POWER SUPPLY FUNCTION

CONSULT

1. Turn ignition switch ON.
2. Turn each interior room lamp ON:
 - Front room/map lamp assembly
 - Cargo lamp
 - Room lamp 2nd row
3. Select "BATTERY SAVER" of BCM (BATTERY SAVER) active test item.
4. While operating the test item, check that each interior room lamp turns ON/OFF.

OFF : Interior room lamp OFF

ON : Interior room lamp ON

Is the inspection result normal?

YES >> Battery saver output/power supply circuit is normal.

NO >> Refer to [INL-16, "Diagnosis Procedure"](#).

Diagnosis Procedure

INFOID:000000011068484

Regarding Wiring Diagram information, refer to [INL-35, "Wiring Diagram"](#).

1. CHECK BATTERY SAVER OUTPUT/POWER SUPPLY OUTPUT

CONSULT

1. Turn ignition switch ON.
2. Select "BATTERY SAVER" of BCM (BATTERY SAVER) active test item.
3. While operating the test item, check voltage between BCM connector M20 terminal 56 and ground.

(+)		(-)	Test item	Voltage
Connector	Terminal		BATTERY SAVER	
M20	56	Ground	OFF	0V
			ON	Battery voltage

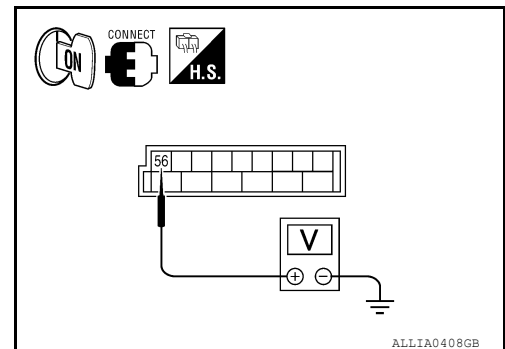

Is the inspection result normal?

YES >> GO TO 2.

NO >> Replace BCM after making sure the battery saver output/power supply circuit is not shorted to voltage. Refer to [BCS-51, "Removal and Installation"](#).

2. CHECK BATTERY SAVER OUTPUT/POWER SUPPLY OPEN CIRCUIT

1. Turn ignition switch OFF.
2. Disconnect the following connectors:
 - BCM M20
 - Ignition keyhole illumination
 - Front room/map lamp assembly
 - Cargo lamp
 - Room lamp 2nd row

BATTERY SAVER OUTPUT/POWER SUPPLY CIRCUIT

< DTC/CIRCUIT DIAGNOSIS >

3. Check continuity between BCM connector and each interior room lamp connector.

BCM		Interior room lamp			Continuity
Connector	Terminal	Connector		Terminal	
M20	56	Ignition keyhole illumination	M150	1	Yes
		Front room/map lamp assembly	R9	1	
		Cargo lamp	R11	2	
		Room lamp 2nd row	R12	2	

Is the inspection result normal?

YES >> GO TO 3.

NO >> Repair the harness or connectors.

3.CHECK BATTERY SAVER OUTPUT/POWER SUPPLY SHORT CIRCUIT

Check continuity between BCM connector M20 terminal 56 and ground.

Connector	Terminal	-	Continuity
M20	56	Ground	No

Is the inspection result normal?

YES >> Replace the interior room lamp. Refer to [INL-59](#).
"Removal and Installation".

NO >> Repair the harness or connectors.

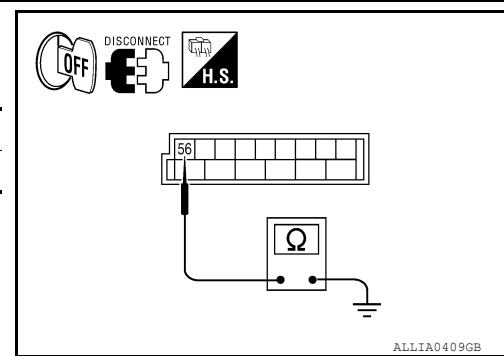

ALLIA0409GB

A
B
C
D
E
F
G
H
I
J
K
L
M
N
O
P

INL

INTERIOR ROOM LAMP CONTROL CIRCUIT

< DTC/CIRCUIT DIAGNOSIS >

INTERIOR ROOM LAMP CONTROL CIRCUIT

Description

INFOID:000000011068485

Controls the following interior room lamps (ground side) by PWM signal:

- Front room/map lamp assembly
- Room lamp 2nd row

NOTE:

PWM signal control period is approximately 250 Hz (in the gradual brightening/dimming).

Component Function Check

INFOID:000000011068486

CAUTION:

Before performing the diagnosis, check that the following is normal:

- Battery saver output/power supply
- Front room/map lamp bulbs
- Room lamp 2nd row bulb

1. CHECK INTERIOR ROOM LAMP CONTROL FUNCTION

CONSULT

1. Switch the front room/map lamp assembly and room lamp 2nd row switches to DOOR.
2. Turn ignition switch ON.
3. Select "INT LAMP" of BCM (INT LAMP) active test item.
4. While operating the test item, check that each interior room lamp turns ON/OFF (gradual brightening/dimming).

ON : Interior room lamp gradual brightening

OFF : Interior room lamp gradual dimming

Is the inspection result normal?

YES >> Interior room lamp control circuit is normal.

NO >> Refer to [INL-18, "Diagnosis Procedure"](#).

Diagnosis Procedure

INFOID:000000011068487

Regarding Wiring Diagram information, refer to [INL-35, "Wiring Diagram"](#).

1. CHECK INTERIOR ROOM LAMP CONTROL OUTPUT

CONSULT

1. Turn ignition switch ON.
2. Select "INT LAMP" of BCM (INT LAMP) active test item.
3. While operating the test item, check voltage between BCM connector M20 terminal 63 and ground.

(+)		(-)	INT LAMP	Voltage
Connector	Terminal			
M20	63	Ground	ON	0V
			OFF	Battery voltage

Is the inspection result normal?

YES >> Interior room lamp control circuit is operating normally.

Fixed ON >> GO TO 3.

Fixed OFF >> GO TO 2.

2. CHECK INTERIOR ROOM LAMP CONTROL OPEN CIRCUIT

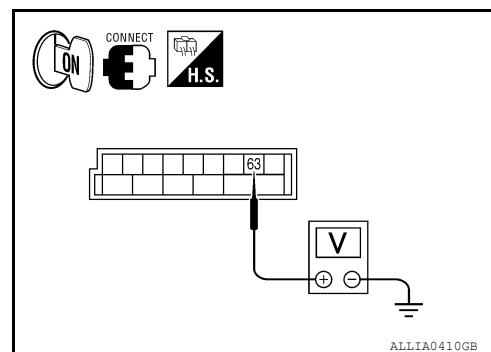

INTERIOR ROOM LAMP CONTROL CIRCUIT

< DTC/CIRCUIT DIAGNOSIS >

1. Turn ignition switch OFF.
2. Disconnect BCM connector M20, room lamp 2nd row connector and front room/map lamp connector.
3. Check continuity between BCM connector M20 (A) terminal 63 and interior room lamp connectors.

Terminal		Terminal			Continuity
Connector	Terminal	Component	Connector	Terminal	
M20 (A)	63	Room lamp 2nd row	R12 (B)	1	Yes
		Front room/map lamp	R9 (C)	2	

Is the inspection result normal?

- YES >> Check interior room lamp for an open. If OK, replace the BCM. Refer to [BCS-51, "Removal and Installation"](#). If NG, replace the interior room lamp. Refer to [INL-59, "Removal and Installation"](#).
- NO >> Repair the harness or connectors.

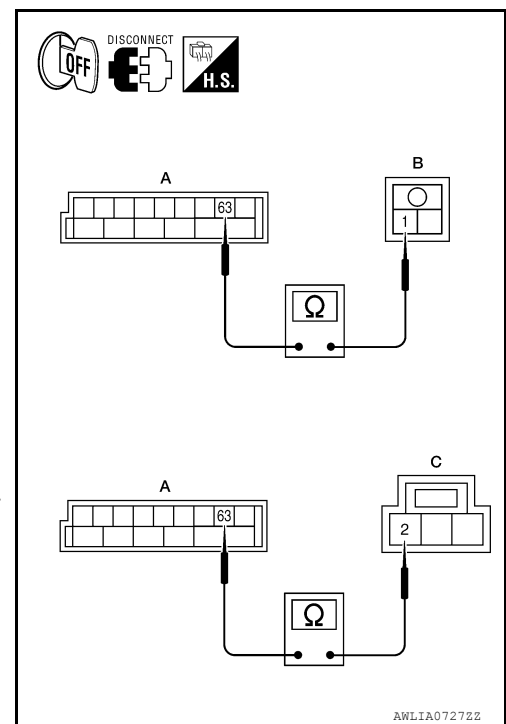

3. CHECK INTERIOR ROOM LAMP CONTROL SHORT CIRCUIT

1. Turn ignition switch OFF.
2. Disconnect BCM connector M20, room lamp 2nd row connector and front room/map lamp connector.
3. Check continuity between BCM connector M20 terminal 63 and ground.

Connector	Terminal	-	Continuity
M20	63	Ground	No

Is the inspection result normal?

- YES >> Check interior room lamp for a short circuit. If OK, replace the BCM. Refer to [BCS-51, "Removal and Installation"](#). If NG, replace the interior room lamp. Refer to [INL-59, "Removal and Installation"](#).
- NO >> Repair the harness or connectors.

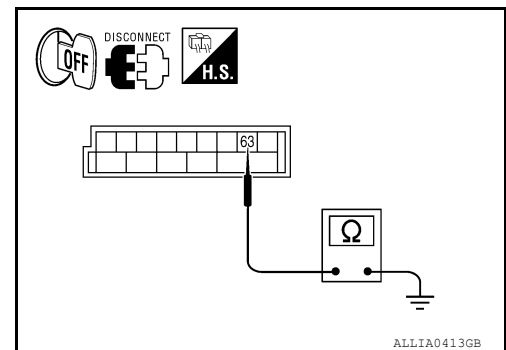

A
B
C
D
E
F
G
H
I
J
K
L
M
N
O
P

INL

CARGO LAMP CONTROL CIRCUIT

< DTC/CIRCUIT DIAGNOSIS >

CARGO LAMP CONTROL CIRCUIT

Description

INFOID:000000011068488

Controls the cargo lamp (ground side) to turn the cargo lamp ON and OFF.

Component Function Check

INFOID:000000011068489

CAUTION:

Before performing the diagnosis, check that the following is normal:

- Battery saver output/power supply
- Cargo lamp bulb

1.CHECK CARGO LAMP OPERATION

CONSULT

1. Turn ignition switch ON.
2. Select "LUGGAGE LAMP TEST" of BCM (INT LAMP) active test item.
3. While operating the test item, check that cargo lamp turns ON/OFF.

ON : Cargo lamp ON

OFF : Cargo lamp OFF

Is the inspection result normal?

- YES >> Cargo lamp circuit is normal.
NO >> Refer to [INL-20, "Diagnosis Procedure"](#).

Diagnosis Procedure

INFOID:000000011068490

Regarding Wiring Diagram information, refer to [INL-35, "Wiring Diagram"](#).

1.CHECK CARGO LAMP OUTPUT

CONSULT

1. Turn ignition switch ON.
2. Select "LUGGAGE LAMP TEST" of BCM (INT LAMP) active test item.
3. While operating the test item, check voltage between BCM connector M19 terminal 49 and ground.

Connector	Terminal	-	LUGGAGE LAMP TEST	Voltage
M19	49	Ground	ON	0V
			OFF	Battery voltage

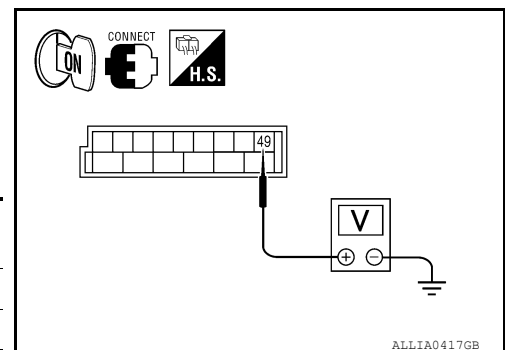

Is the inspection result normal?

- YES >> Cargo lamp control circuit is operating normally.
Fixed ON>> GO TO 3.
Fixed OFF>> GO TO 2.

2.CHECK CARGO LAMP OPEN CIRCUIT

CARGO LAMP CONTROL CIRCUIT

< DTC/CIRCUIT DIAGNOSIS >

1. Turn ignition switch OFF.
2. Disconnect BCM connector M19 and cargo lamp connector.
3. Check continuity between BCM connector M19 (A) terminal 49 and cargo lamp connector R11 (B) terminal 1.

BCM		Cargo lamp		Continuity
Connector	Terminal	Connector	Terminal	
M19 (A)	49	R11 (B)	1	Yes

Is the inspection result normal?

- YES >> Check cargo lamp for an open. If OK, replace BCM. Refer to [BCS-51, "Removal and Installation"](#). If NG, replace cargo lamp. Refer to [INL-59, "Removal and Installation"](#).
- NO >> Repair harness or connectors.

3. CHECK CARGO LAMP SHORT CIRCUIT

1. Turn ignition switch OFF.
2. Disconnect BCM connector M19 and cargo lamp connector.
3. Check continuity between BCM connector M19 terminal 49 and ground.

Connector	Terminal	-	Continuity
M19	49	Ground	No

Is the inspection result normal?

- YES >> Check cargo lamp for a short circuit. If OK, replace BCM. Refer to [BCS-51, "Removal and Installation"](#). If NG, replace cargo lamp. Refer to [INL-59, "Removal and Installation"](#).
- NO >> Repair harness or connectors.

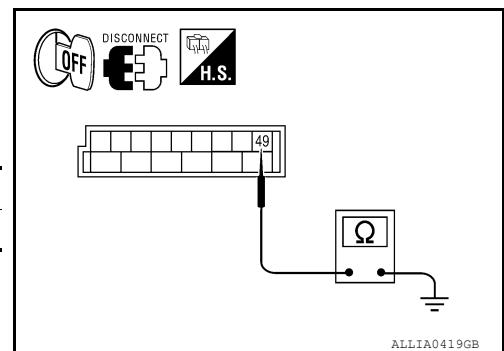
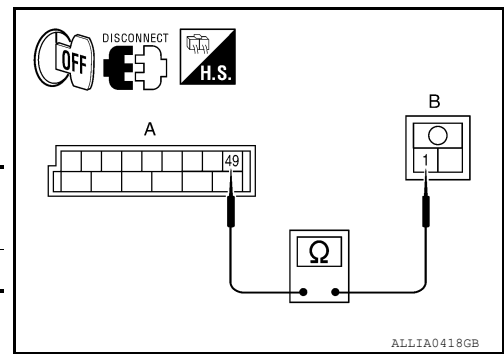

A
B
C
D
E
F
G
H
I
J
K
L
M
N
O
P

INL

IGNITION KEYHOLE ILLUMINATION CONTROL CIRCUIT

< DTC/CIRCUIT DIAGNOSIS >

IGNITION KEYHOLE ILLUMINATION CONTROL CIRCUIT

Description

INFOID:000000011068491

Controls the ignition keyhole illumination (ground side) to turn the ignition keyhole illumination ON and OFF.

Component Function Check

INFOID:000000011068492

CAUTION:

Before performing the diagnosis, check that the following is normal:

- Battery saver output/power supply circuit
- Ignition keyhole illumination bulb

1.CHECK IGNITION KEYHOLE ILLUMINATION OPERATION

CONSULT

1. Turn the ignition switch ON.
2. Select "IGN ILLUM" of BCM (INT LAMP) active test item.
3. While operating the test item, check that the ignition keyhole illumination turns ON/OFF

ON : Ignition keyhole illumination ON

OFF : Ignition keyhole illumination OFF

Is the inspection result normal?

- YES >> Ignition keyhole illumination circuit is normal.
NO >> Refer to [INL-22, "Diagnosis Procedure"](#).

Diagnosis Procedure

INFOID:000000011068493

Regarding Wiring Diagram information, refer to [INL-35, "Wiring Diagram"](#).

1.CHECK IGNITION KEYHOLE OUTPUT

CONSULT

1. Turn ignition switch ON.
2. Select "IGN ILLUM" of BCM (INT LAMP) active test item.
3. While operating the test item, check voltage between BCM connector M18 terminal 1 and ground.

Connector	Terminal	—	IGN ILLUM	Voltage
M18	1	Ground	ON	0V
			OFF	Battery voltage

Is the inspection result normal?

- YES >> Ignition keyhole illumination control circuit is operating normally.
Fixed ON>> GO TO 3.
Fixed OFF>> GO TO 2.

2.CHECK IGNITION KEYHOLE ILLUMINATION OPEN CIRCUIT

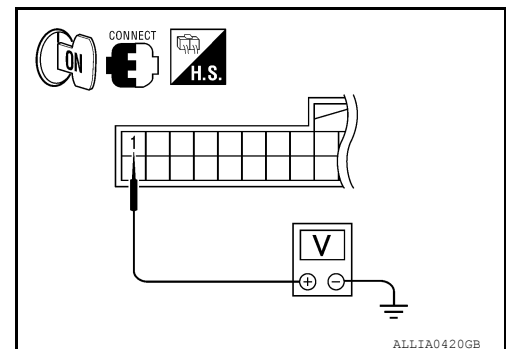

IGNITION KEYHOLE ILLUMINATION CONTROL CIRCUIT

< DTC/CIRCUIT DIAGNOSIS >

1. Turn ignition switch OFF.
2. Disconnect BCM connector M18 and ignition keyhole illumination connector.
3. Check continuity between BCM connector M18 (A) terminal 1 and ignition keyhole illumination connector M150 (B) terminal 2.

BCM		Ignition keyhole illumination		Continuity
Connector	Terminal	Connector	Terminal	
M18 (A)	1	M150 (B)	2	Yes

Is the inspection result normal?

YES >> Check the ignition keyhole illumination for an open. If OK, replace the BCM. Refer to [BCS-51, "Removal and Installation"](#). If NG, replace ignition keyhole illumination. Refer to [INL-62, "Removal and Installation"](#).

NO >> Repair harness or connectors.

3. CHECK IGNITION KEYHOLE ILLUMINATION SHORT CIRCUIT

1. Turn ignition switch OFF.
2. Disconnect BCM connector M18 and ignition keyhole illumination connector.
3. Check continuity between BCM connector M18 terminal 1 and ground.

Connector	Terminal	-	Continuity
M18	1	Ground	No

Is the inspection result normal?

YES >> Check the ignition keyhole illumination for a short circuit. If OK, replace the BCM. Refer to [BCS-51, "Removal and Installation"](#). If NG, replace ignition keyhole illumination. Refer to [INL-62, "Removal and Installation"](#).

NO >> Repair harness or connectors.

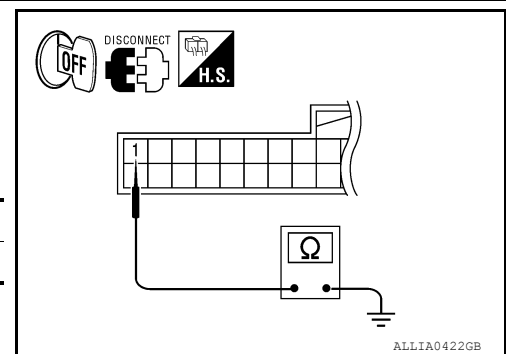
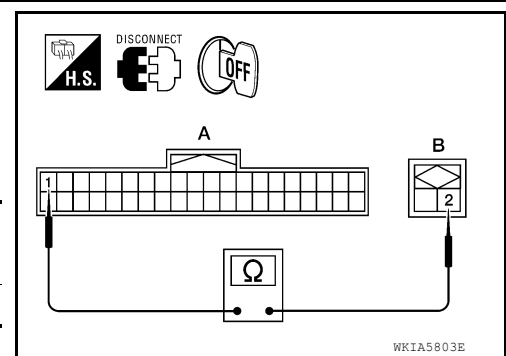

A
B
C
D
E
F
G
H
I
J
K
L
M
N
O
P

INL

BCM (BODY CONTROL MODULE)

< ECU DIAGNOSIS INFORMATION >

ECU DIAGNOSIS INFORMATION

BCM (BODY CONTROL MODULE)

Reference Value

INFOID:0000000011376552

NOTE:

The Signal Tech II Tool [– (J-50190)] can be used to perform the following functions. Refer to the Signal Tech II User Guide for additional information.

- Activate and display TPMS transmitter IDs
- Display tire pressure reported by the TPMS transmitter
- Read TPMS DTCs
- Register TPMS transmitter IDs

VALUES ON THE DIAGNOSIS TOOL

Monitor Item	Condition	Value/Status
ACC ON SW	Ignition switch OFF or ON	Off
	Ignition switch ACC	On
AIR COND SW	A/C switch OFF	Off
	A/C switch ON	On
AIR PRESS FL	Front left tire air pressure value	kPa, kg/cm ² , psi
AIR PRESS FR	Front right tire air pressure value	kPa, kg/cm ² , psi
AIR PRESS RL	Rear left tire air pressure value	kPa, kg/cm ² , psi
AIR PRESS RR	Rear right tire air pressure value	kPa, kg/cm ² , psi
AUTO LIGHT SW	Lighting switch OFF	Off
	Lighting switch AUTO	On
BACK DOOR SW	Back door closed	Off
	Back door opened	On
BRAKE SW	Brake pedal released	Off
	Brake pedal applied	On
BUCKLE SW	Seat belt buckle unfastened	Off
	Seat belt buckle fastened	On
BUZZER	Buzzer in combination meter OFF	Off
	Buzzer in combination meter ON	On
CARGO LAMP SW	Cargo lamp switch OFF	Off
	Cargo lamp switch ON	On
CDL LOCK SW	Door lock/unlock switch does not operate	Off
	Press door lock/unlock switch to the LOCK side	On
CDL UNLOCK SW	Door lock/unlock switch does not operate	Off
	Press door lock/unlock switch to the UNLOCK side	On
DOOR SW-AS	Front door RH closed	Off
	Front door RH opened	On
DOOR SW-DR	Front door LH closed	Off
	Front door LH opened	On
DOOR SW-RL	Rear door LH closed	Off
	Rear door LH opened	On
DOOR SW-RR	Rear door RH closed	Off
	Rear door RH opened	On

BCM (BODY CONTROL MODULE)

< ECU DIAGNOSIS INFORMATION >

Monitor Item	Condition	Value/Status	
ENGINE RUN	Engine stopped	Off	A
	Engine running	On	
FAN ON SIG	Blower motor fan switch OFF	Off	B
	Blower motor fan switch ON	On	
FR FOG SW	Front fog lamp switch OFF	Off	C
	Front fog lamp switch ON	On	
FR WASHER SW	Front washer switch OFF	Off	D
	Front washer switch ON	On	
FR WIPER LOW	Front wiper switch OFF	Off	E
	Front wiper switch LO	On	
FR WIPER HI	Front wiper switch OFF	Off	F
	Front wiper switch HI	On	
FR WIPER INT	Front wiper switch OFF	Off	G
	Front wiper switch INT	On	
FR WIPER STOP	Any position other than front wiper stop position	Off	H
	Front wiper stop position	On	
HAZARD SW	When hazard switch is not pressed	Off	I
	When hazard switch is pressed	On	
HEAD LAMP SW 1	Headlamp switch OFF	Off	J
	Headlamp switch 1st	On	
HEAD LAMP SW 2	Headlamp switch OFF	Off	K
	Headlamp switch 1st	On	
HI BEAM SW	High beam switch OFF	Off	L
	High beam switch HI	On	
ID REGST FL1	ID registration of front left tire incomplete	YET	M
	ID registration of front left tire complete	DONE	
ID REGST FR1	ID registration of front right tire incomplete	YET	N
	ID registration of front right tire complete	DONE	
ID REGST RL1	ID registration of rear left tire incomplete	YET	O
	ID registration of rear left tire complete	DONE	
ID REGST RR1	ID registration of rear right tire incomplete	YET	P
	ID registration of rear right tire complete	DONE	
IGN ON SW	Ignition switch OFF or ACC	Off	
	Ignition switch ON	On	
IGN SW CAN	Ignition switch OFF or ACC	Off	
	Ignition switch ON	On	
INT VOLUME	Wiper intermittent dial is in a dial position 1 - 7	1 - 7	
KEY CYL LK-SW	Door key cylinder LOCK position	Off	
	Door key cylinder other than LOCK position	On	
KEY CYL UN-SW	Door key cylinder UNLOCK position	Off	
	Door key cylinder other than UNLOCK position	On	
KEY ON SW	Mechanical key is removed from key cylinder	Off	
	Mechanical key is inserted to key cylinder	On	

BCM (BODY CONTROL MODULE)

< ECU DIAGNOSIS INFORMATION >

Monitor Item	Condition	Value/Status
KEYLESS LOCK	LOCK button of key fob is not pressed	Off
	LOCK button of key fob is pressed	On
KEYLESS PANIC	PANIC button of key fob is not pressed	Off
	PANIC button of key fob is pressed	On
KEYLESS UNLOCK	UNLOCK button of key fob is not pressed	Off
	UNLOCK button of key fob is pressed	On
LIGHT SW 1ST	Lighting switch OFF	Off
	Lighting switch 1st	On
OIL PRESS SW	<ul style="list-style-type: none"> • Ignition switch OFF or ACC • Engine running 	Off
	Ignition switch ON	On
OPTICAL SENSOR	Bright outside of the vehicle	Close to 5V
	Dark outside of the vehicle	Close to 0V
PASSING SW	Other than lighting switch PASS	Off
	Lighting switch PASS	On
PKB SW	Parking brake released	Off
	Parking brake engaged	On
REAR DEF SW	Rear window defogger switch OFF	Off
	Rear window defogger switch ON	On
RR WASHER SW	Rear washer switch OFF	Off
	Rear washer switch ON	On
RR WIPER INT	Rear wiper switch OFF	Off
	Rear wiper switch INT	On
RR WIPER ON	Rear wiper switch OFF	Off
	Rear wiper switch ON	On
RR WIPER STOP	Rear wiper stop position	Off
	Other than rear wiper stop position	On
TURN SIGNAL L	Turn signal switch OFF	Off
	Turn signal switch LH	On
TURN SIGNAL R	Turn signal switch OFF	Off
	Turn signal switch RH	On
VEHICLE SPEED	While driving	Equivalent to speedometer reading
WARNING LAMP	Low tire pressure warning lamp in combination meter OFF	Off
	Low tire pressure warning lamp in combination meter ON	On

BCM (BODY CONTROL MODULE)

< ECU DIAGNOSIS INFORMATION >

Terminal Layout

INFOID:0000000011376553

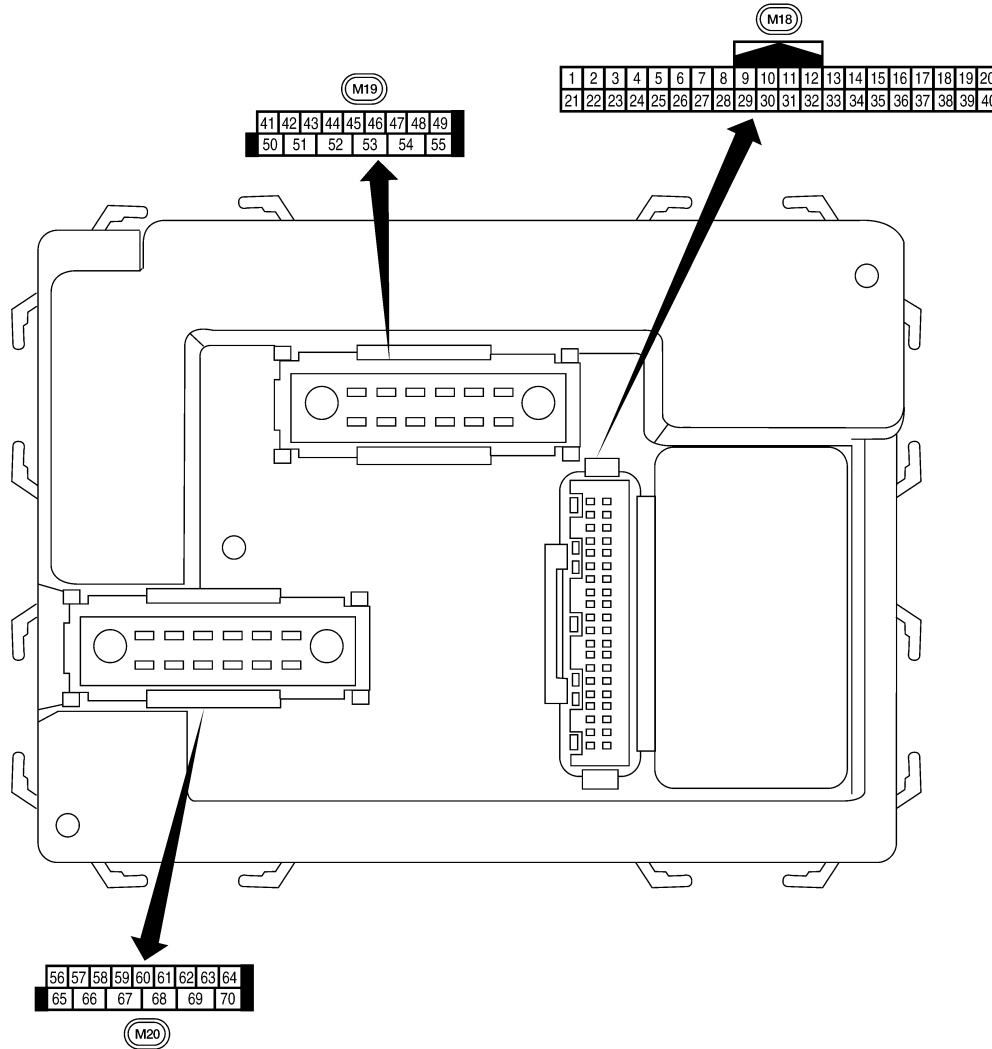

A
B
C
D
E
F
G
H
I
J
K
L
M
N
O
P

INL



Physical Values

LIIA2443E

INFOID:0000000011376554

BCM (BODY CONTROL MODULE)

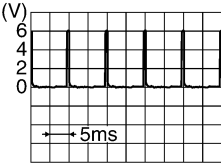
< ECU DIAGNOSIS INFORMATION >

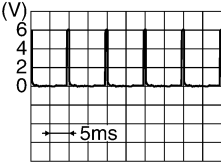
Terminal	Wire color	Signal name	Signal input/output	Measuring condition		Reference value or waveform (Approx.)
				Ignition switch	Operation or condition	
1	BR	Ignition keyhole illumination	Output	OFF	Door is locked (SW OFF)	Battery voltage
					Door is unlocked (SW ON)	0V
2	P	Combination switch input 5	Input	ON	Lighting, turn, wiper OFF Wiper dial position 4	 <p style="text-align: right; font-size: small;">SKIA5291E</p>
3	SB	Combination switch input 4	Input	ON	Lighting, turn, wiper OFF Wiper dial position 4	 <p style="text-align: right; font-size: small;">SKIA5292E</p>
4	V	Combination switch input 3	Input	ON	Lighting, turn, wiper OFF Wiper dial position 4	 <p style="text-align: right; font-size: small;">SKIA5291E</p>
5	L	Combination switch input 2	Input	ON	Lighting, turn, wiper OFF Wiper dial position 4	 <p style="text-align: right; font-size: small;">SKIA5292E</p>
6	R	Combination switch input 1				
7	GR	Front door lock assembly LH (key cylinder switch) and back door key cylinder switch (unlock)	Input	OFF	ON (open, 2nd turn)	Momentary 1.5V
					OFF (closed)	0V
8	SB	Front door lock assembly LH (key cylinder switch) and back door key cylinder switch (lock)	Input	OFF	ON (open)	Momentary 1.5V
					OFF (closed)	0V
9	LG	Stop lamp switch	Input	OFF	Brake pedal depressed	Battery voltage
					Brake pedal released	0V
11	G/B	Ignition switch (ACC or ON)	Input	ACC or ON	Ignition switch ACC or ON	Battery voltage
12	LG	Front door switch RH	Input	OFF	ON (open)	0V
					OFF (closed)	Battery voltage
13	L	Rear door switch RH	Input	OFF	ON (open)	0V
					OFF (closed)	Battery voltage

BCM (BODY CONTROL MODULE)

< ECU DIAGNOSIS INFORMATION >

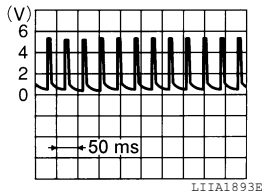
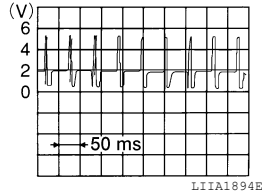
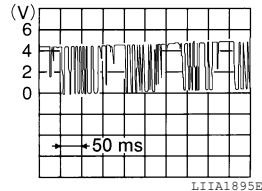



Terminal	Wire color	Signal name	Signal input/output	Measuring condition		Reference value or waveform (Approx.)
				Ignition switch	Operation or condition	
15	W	Tire pressure warning check connector	Input	OFF	—	5V
18	BR	Remote keyless entry receiver and optical sensor (ground)	Output	OFF	—	0V
19	V	Remote keyless entry receiver (power supply)	Output	OFF	Ignition switch OFF	
20	G	Remote keyless entry receiver (signal)	Input	OFF	Stand-by (keyfob buttons released)	
					When remote keyless entry receiver receives signal from keyfob (keyfob buttons pressed)	
21	GR	NATS antenna amp.	Input	OFF → ON	Ignition switch (OFF → ON)	Just after turning ignition switch ON: Pointer of tester should move for approx. 1 second, then return to battery voltage.
23	G	Security indicator lamp	Output	OFF	Goes OFF → illuminates (Every 2.4 seconds)	Battery voltage → 0V
25	BR	NATS antenna amp.	Input	OFF → ON	Ignition switch (OFF → ON)	Just after turning ignition switch ON: Pointer of tester should move for approx. 1 second, then return to battery voltage.
27	W	Compressor ON signal	Input	ON	A/C switch OFF	5V
					A/C switch ON	0V
28	R	Front blower monitor	Input	ON	Front blower motor OFF	Battery voltage
					Front blower motor ON	0V
29	G	Hazard switch	Input	OFF	ON	0V
					OFF	5V
31	R	Off-road lamps switch	Input	ON	ON	0V
					OFF	5V

A
B
C
D
E
F
G
H
I
J
K
M
N
O
P

INL

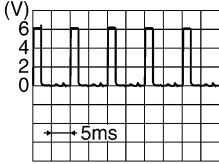
BCM (BODY CONTROL MODULE)

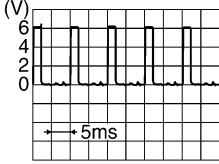
< ECU DIAGNOSIS INFORMATION >

Terminal	Wire color	Signal name	Signal input/output	Measuring condition		Reference value or waveform (Approx.)
				Ignition switch	Operation or condition	
32	BG	Combination switch output 5	Output	ON	Lighting, turn, wiper OFF Wiper dial position 4	 <p style="text-align: right; font-size: small;">SKIA5291E</p>
33	GR	Combination switch output 4	Output	ON	Lighting, turn, wiper OFF Wiper dial position 4	 <p style="text-align: right; font-size: small;">SKIA5292E</p>
34	G	Combination switch output 3	Output	ON	Lighting, turn, wiper OFF Wiper dial position 4	 <p style="text-align: right; font-size: small;">SKIA5291E</p>
35	BR	Combination switch output 2	Output	ON	Lighting, turn, wiper OFF Wiper dial position 4	 <p style="text-align: right; font-size: small;">SKIA5292E</p>
36	LG	Combination switch output 1				
37	B	Key switch and key lock solenoid	Input	OFF	Key inserted	Battery voltage
					Key removed	0V
38	W/R	Ignition switch (ON)	Input	ON	—	Battery voltage
39	L	CAN high	—	—	—	—
40	P	CAN low	—	—	—	—
41	Y	Rear window defogger switch	Input	ON	Rear window defogger switch ON	0V
					Rear window defogger switch OFF	5V
42	L	Off-road lamps	Output	ON	Off-road lamps switch ON	0V
					Off-road lamps switch OFF	Battery voltage
43	Y	Back door switch	Input	OFF	ON (open)	0V
					OFF (closed)	Battery voltage

BCM (BODY CONTROL MODULE)

< ECU DIAGNOSIS INFORMATION >

Terminal	Wire color	Signal name	Signal input/output	Measuring condition		Reference value or waveform (Approx.)
				Ignition switch	Operation or condition	
44	BG	Rear wiper auto stop switch	Input	ON	Rise up position (rear wiper arm on stopper)	0V
					A Position (full clockwise stop position)	Battery voltage
					Forward sweep (counterclockwise direction)	Fluctuating
					B Position (full counterclockwise stop position)	0V
					Reverse sweep (clockwise direction)	Fluctuating
45	V	Lock switch	Input	OFF	ON (lock)	0V
					OFF	Battery voltage
46	LG	Unlock switch	Input	OFF	ON (unlock)	0V
					OFF	Battery voltage
47	GR	Front door switch LH	Input	OFF	ON (open)	0V
					OFF (closed)	Battery voltage
48	P	Rear door switch LH	Input	OFF	ON (open)	0V
					OFF (closed)	Battery voltage
49	L	Cargo lamp	Output	OFF	Any door open (ON)	0V
					All doors closed (OFF)	Battery voltage
50	W	Off-road lamps relay	Output	ON	Off-road lamps switch	ON
					OFF	Battery voltage
51	BG	Trailer turn signal (right)	Output	ON	Turn right ON	<p style="text-align: right; font-size: small;">SKIA3009J</p>
52	LG	Trailer turn signal (left)	Output	ON	Turn left ON	<p style="text-align: right; font-size: small;">SKIA3009J</p>
55	W	Rear wiper output circuit 1	Output	ON	OFF	0
					ON	Battery voltage
56	R/Y	Battery saver output	Output	OFF	10 minutes after ignition switch is turned OFF	0V
				ON	—	Battery voltage
57	R/Y	Battery power supply	Input	OFF	—	Battery voltage
58	W	Optical sensor	Input	ON	When optical sensor is illuminated	3.1V or more
					When optical sensor is not illuminated	0.6V or less

A
B
C
D
E
F
G
H
I
J
K
INL
M
N
O
P

BCM (BODY CONTROL MODULE)

< ECU DIAGNOSIS INFORMATION >

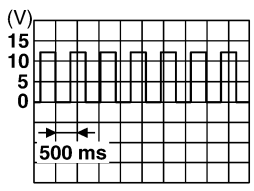
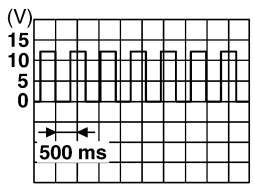
Terminal	Wire color	Signal name	Signal input/output	Measuring condition		Reference value or waveform (Approx.)
				Ignition switch	Operation or condition	
59	GR	Front door lock assembly LH actuator (unlock)	Output	OFF	OFF (neutral)	0V
					ON (unlock)	Battery voltage
60	LG	Turn signal (left)	Output	ON	Turn left ON	 <small>SKIA3009J</small>
61	G	Turn signal (right)	Output	ON	Turn right ON	 <small>SKIA3009J</small>
63	BR	Interior room/map lamp	Output	OFF	Any door switch ON (open)	0V
					OFF (closed)	Battery voltage
65	V	All door lock actuators (lock)	Output	OFF	OFF (neutral)	0V
					ON (lock)	Battery voltage
66	L	Front door lock actuator RH, rear door lock actuators LH/RH and back door lock actuator (unlock)	Output	OFF	OFF (neutral)	0V
					ON (unlock)	Battery voltage
67	B	Ground	Input	ON	—	0V
68	SB	Power window power supply (RAP)	Output	—	Ignition switch ON	Battery voltage
					Within 45 seconds after ignition switch OFF	Battery voltage
					More than 45 seconds after ignition switch OFF	0V
					When front door LH or RH is open or power window timer operates	0V
70	W	Battery power supply	Input	OFF	—	Battery voltage

Fail Safe

INFOID:000000011376555

Fail-safe index

BCM performs fail-safe control when any DTC listed below is detected.

Display contents of CONSULT	Fail-safe	Cancellation
U1000: CAN COMM CIRCUIT	Inhibit engine cranking	When the BCM re-establishes communication with the other modules.

DTC Inspection Priority Chart

INFOID:000000011376556

If some DTCs are displayed at the same time, perform inspections one by one based on the following priority chart.

BCM (BODY CONTROL MODULE)

< ECU DIAGNOSIS INFORMATION >

Priority	DTC	
1	• U1000: CAN COMM CIRCUIT	A
2	• B2190: NATS ANTENNA AMP • B2191: DIFFERENCE OF KEY • B2192: ID DISCORD BCM-ECM • B2193: CHAIN OF BCM-ECM	B
3	• C1729: VHCL SPEED SIG ERR • C1735: IGNITION SIGNAL	C
4	• C1704: LOW PRESSURE FL • C1705: LOW PRESSURE FR • C1706: LOW PRESSURE RR • C1707: LOW PRESSURE RL • C1708: [NO DATA] FL • C1709: [NO DATA] FR • C1710: [NO DATA] RR • C1711: [NO DATA] RL • C1712: [CHECKSUM ERR] FL • C1713: [CHECKSUM ERR] FR • C1714: [CHECKSUM ERR] RR • C1715: [CHECKSUM ERR] RL • C1716: [PRESSDATA ERR] FL • C1717: [PRESSDATA ERR] FR • C1718: [PRESSDATA ERR] RR • C1719: [PRESSDATA ERR] RL • C1720: [CODE ERR] FL • C1721: [CODE ERR] FR • C1722: [CODE ERR] RR • C1723: [CODE ERR] RL • C1724: [BATT VOLT LOW] FL • C1725: [BATT VOLT LOW] FR • C1726: [BATT VOLT LOW] RR • C1727: [BATT VOLT LOW] RL	D E F G H I J

DTC Index

INFOID:000000011376557

NOTE:

- Details of time display
- CRNT: Displays when there is a malfunction now or after returning to the normal condition until turning ignition switch OFF → ON again.
- 1 - 39: Displayed if any previous malfunction is present when current condition is normal. It increases like 1 → 2 → 3...38 → 39 after returning to the normal condition whenever ignition switch OFF → ON. The counter remains at 39 even if the number of cycles exceeds it. It is counted from 1 again when turning ignition switch OFF → ON after returning to the normal condition if the malfunction is detected again.

CONSULT display	Fail-safe	Low tire pressure warning lamp ON	Reference page
No DTC is detected. further testing may be required.	—	—	—
U1000: CAN COMM CIRCUIT	X	—	BCS-27
B2190: NATS ANTENNA AMP	—	—	SEC-18
B2191: DIFFERENCE OF KEY	—	—	SEC-21
B2192: ID DISCORD BCM-ECM	—	—	SEC-22
B2193: CHAIN OF BCM-ECM	—	—	SEC-24
C1708: [NO DATA] FL	—	X	WT-15
C1709: [NO DATA] FR	—	X	WT-15
C1710: [NO DATA] RR	—	X	WT-15
C1711: [NO DATA] RL	—	X	WT-15

BCM (BODY CONTROL MODULE)

< ECU DIAGNOSIS INFORMATION >

CONSULT display	Fail-safe	Low tire pressure warning lamp ON	Reference page
C1712: [CHECKSUM ERR] FL	—	X	WT-17
C1713: [CHECKSUM ERR] FR	—	X	WT-17
C1714: [CHECKSUM ERR] RR	—	X	WT-17
C1715: [CHECKSUM ERR] RL	—	X	WT-17
C1716: [PRESSDATA ERR] FL	—	X	WT-19
C1717: [PRESSDATA ERR] FR	—	X	WT-19
C1718: [PRESSDATA ERR] RR	—	X	WT-19
C1719: [PRESSDATA ERR] RL	—	X	WT-19
C1720: [CODE ERR] FL	—	X	WT-17
C1721: [CODE ERR] FR	—	X	WT-17
C1722: [CODE ERR] RR	—	X	WT-17
C1723: [CODE ERR] RL	—	X	WT-17
C1724: [BATT VOLT LOW] FL	—	X	WT-17
C1725: [BATT VOLT LOW] FR	—	X	WT-17
C1726: [BATT VOLT LOW] RR	—	X	WT-17
C1727: [BATT VOLT LOW] RL	—	X	WT-17
C1729: VHCL SPEED SIG ERR	—	X	WT-21
C1735: IGNITION SIGNAL	—	X	WT-22

INTERIOR ROOM LAMP

< WIRING DIAGRAM >

WIRING DIAGRAM

INTERIOR ROOM LAMP

Wiring Diagram

INFOID:000000011068500

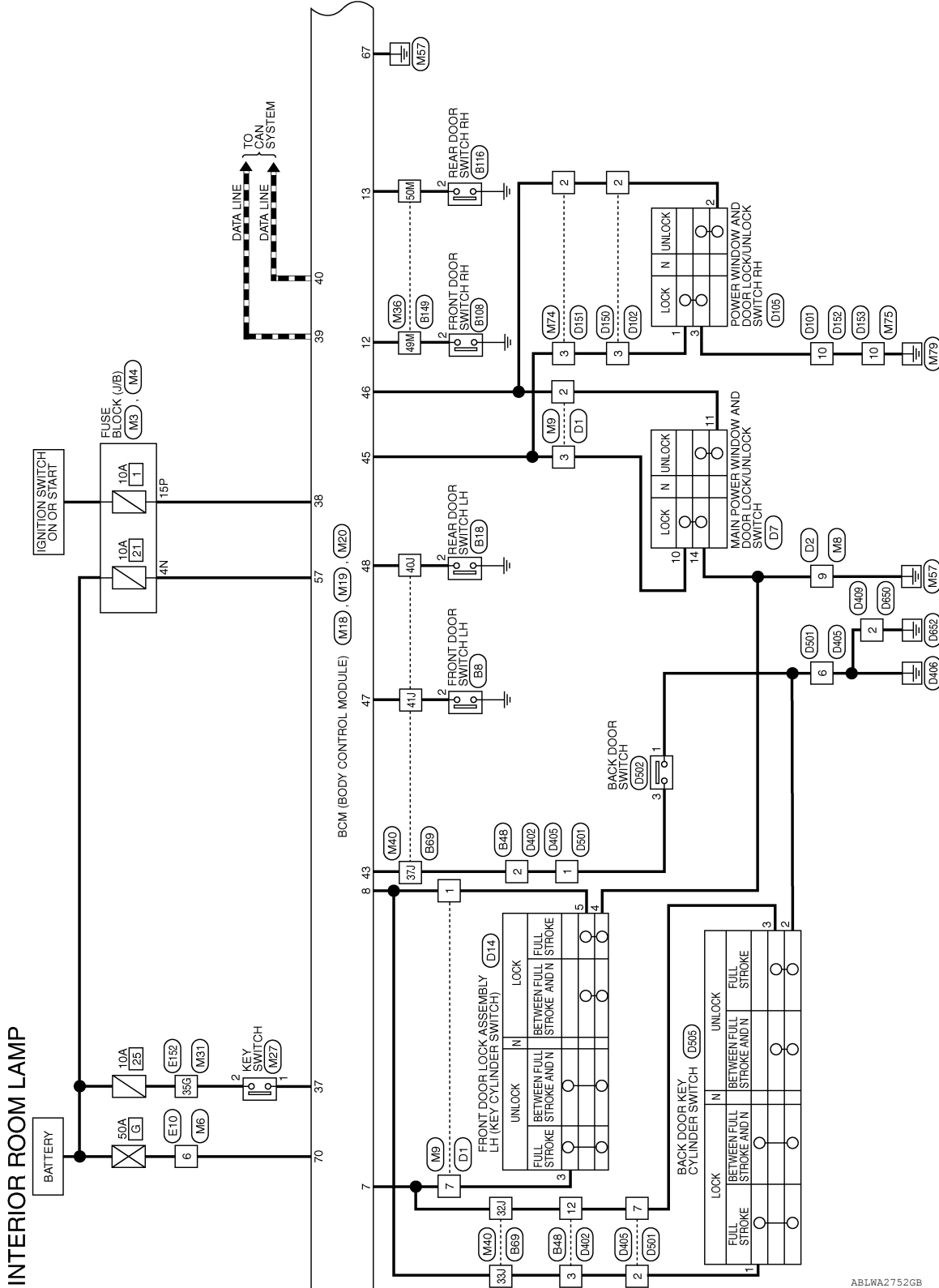

ABLWA2752GB

A
B
C
D
E
F
G
H
I
J
K
L
M
N
O
P

INL

INTERIOR ROOM LAMP

< WIRING DIAGRAM >

IN : WITH IGNITION KEYHOLE ILLUMINATION

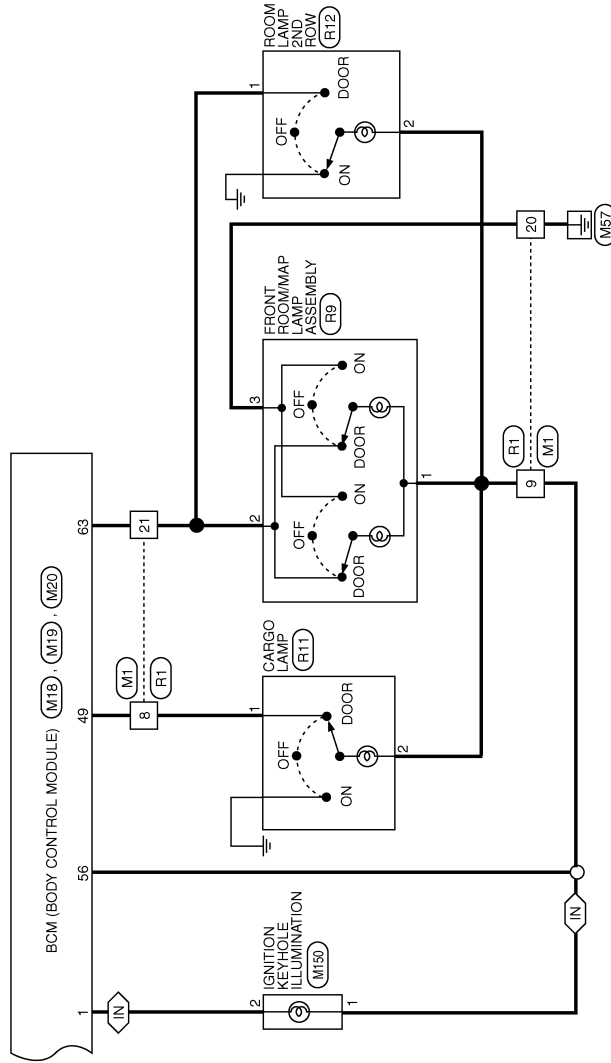

ABLWA2415GB

INTERIOR ROOM LAMP

< WIRING DIAGRAM >

INTERIOR ROOM LAMP CONNECTORS

Connector No.	M1
Connector Name	WIRE TO WIRE
Connector Color	WHITE

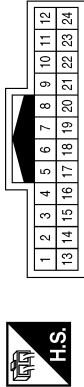

Terminal No.	Color of Wire	Signal Name
8	L	-
9	R/Y	-
20	B	-
21	BR	-

Connector No.	M3
Connector Name	FUSE BLOCK (J/B)
Connector Color	WHITE

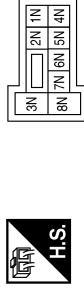

Terminal No.	Color of Wire	Signal Name
4N	R/Y	-

Connector No.	M4
Connector Name	FUSE BLOCK (J/B)
Connector Color	WHITE

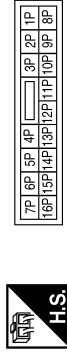

Terminal No.	Color of Wire	Signal Name
15P	W/R	-

Connector No.	M6
Connector Name	WIRE TO WIRE
Connector Color	WHITE



Terminal No.	Color of Wire	Signal Name
6	W	-

Connector No.	M8
Connector Name	WIRE TO WIRE
Connector Color	BROWN

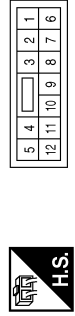

Terminal No.	Color of Wire	Signal Name
9	B	-

Connector No.	M9
Connector Name	WIRE TO WIRE
Connector Color	WHITE

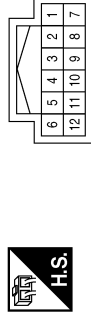

Terminal No.	Color of Wire	Signal Name
1	SB	-
2	LG	-
3	V	-
7	GR	-

ABLIA6700GB

A
B
C
D
E
F
G
H
I
J
K
INL
M
N
O
P

INTERIOR ROOM LAMP

< WIRING DIAGRAM >

Connector No.	M19
Connector Name	BCM (BODY CONTROL MODULE)
Connector Color	WHITE



41	42	43	44	45	46	47	48	49
50	51	52	53	54	55			

Terminal No.	Color of Wire	Signal Name
12	LG	DOOR SW (AS)
13	L	DOOR SW (RR)
37	B	KEY SW
38	W/R	IGN SW
39	L	CAN-H
40	P	CAN-L

Connector No.	M18
Connector Name	BCM (BODY CONTROL MODULE)
Connector Color	WHITE



1	2	3	4	5	6	7	8	9	10	11	12	13	14	15	16	17	18	19	20
21	22	23	24	25	26	27	28	29	30	31	32	33	34	35	36	37	38	39	40

Terminal No.	Color of Wire	Signal Name
43	Y	BACK DOOR SW
45	V	CDL LOCK SW
46	LG	CDL UNLOCK SW
47	GR	DOOR SW (DR)
48	P	DOOR SW (RL)
49	L	CARGO LAMP OUTPUT

Terminal No.	Color of Wire	Signal Name
1	BR	KEY RING OUTPUT
7	GR	KEY CYLINDER UNLOCK SW
8	SB	KEY CYLINDER LOCK SW

Connector No.	M27
Connector Name	KEY SWITCH
Connector Color	WHITE



2	1
---	---

Connector No.	M20
Connector Name	BCM (BODY CONTROL MODULE)
Connector Color	BLACK



56	57	58	59	60	61	62	63	64
65	66	67	68	69	70			

Terminal No.	Color of Wire	Signal Name
1	B	-
2	Y	-

Terminal No.	Color of Wire	Signal Name
56	R/Y	BATTERY SAVER OUTPUT
57	R/Y	BAT (FUSE)
63	BR	ROOM LAMP OUTPUT
67	B	GND (POWER)
70	W	BAT (F/L)

ABLIA6701GB

INTERIOR ROOM LAMP

< WIRING DIAGRAM >

Connector No.	M31
Connector Name	WIRE TO WIRE
Connector Color	WHITE

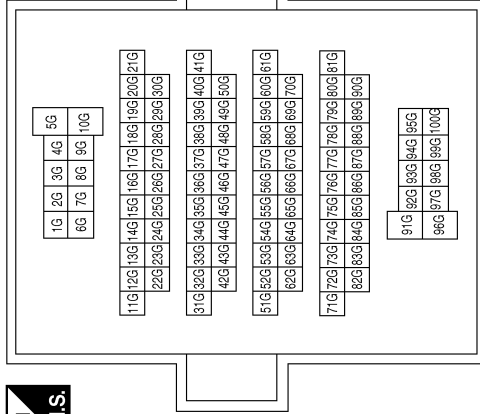

Terminal No.	Color of Wire	Signal Name
35G	Y	-

Connector No.	M36
Connector Name	WIRE TO WIRE
Connector Color	WHITE

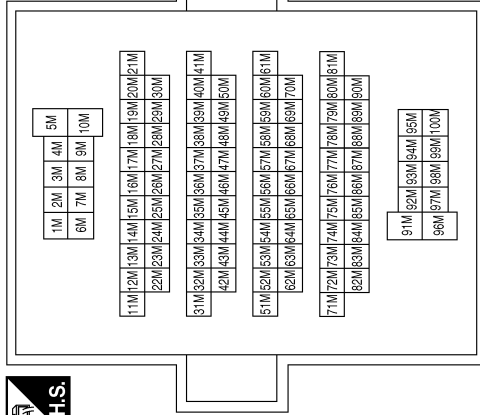

Terminal No.	Color of Wire	Signal Name
49M	LG	-
50M	L	-

Connector No.	M40
Connector Name	WIRE TO WIRE
Connector Color	WHITE

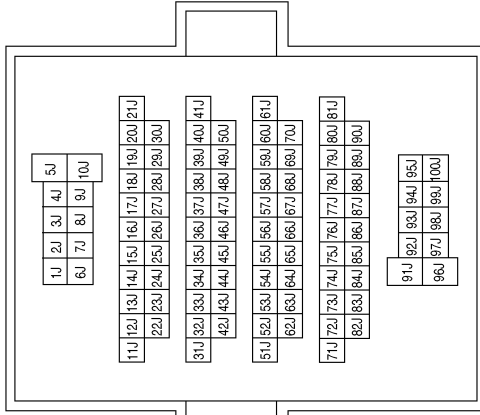

Terminal No.	Color of Wire	Signal Name
32J	GR	-
33J	SB	-
37J	Y	-
40J	P	-
41J	GR	-

Connector No.	M74
Connector Name	WIRE TO WIRE
Connector Color	WHITE

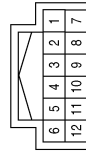

Terminal No.	Color of Wire	Signal Name
2	LG	-
3	P	-

Connector No.	M75
Connector Name	WIRE TO WIRE
Connector Color	WHITE



Terminal No.	Color of Wire	Signal Name
10	B	-

A
B
C
D
E
F
G
H
I
J
K
L
M
N
O
P

INL

INTERIOR ROOM LAMP

< WIRING DIAGRAM >

Connector No.	M150
Connector Name	IGNITION KEY-HOLE ILLUMINATION
Connector Color	WHITE



Terminal No.	Color of Wire	Signal Name
1	R/Y	-
2	BR	-

Connector No.	E10
Connector Name	WIRE TO WIRE
Connector Color	WHITE



Terminal No.	Color of Wire	Signal Name
6	W	-

Connector No.	E152
Connector Name	WIRE TO WIRE
Connector Color	WHITE

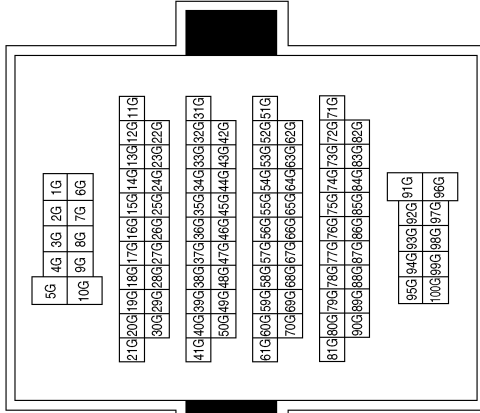

Terminal No.	Color of Wire	Signal Name
35G	Y	-

Connector No.	B8
Connector Name	FRONT DOOR SWITCH LH
Connector Color	WHITE

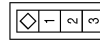

Terminal No.	Color of Wire	Signal Name
2	GR	-

Connector No.	B18
Connector Name	REAR DOOR SWITCH LH
Connector Color	WHITE

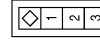

Terminal No.	Color of Wire	Signal Name
2	P	-

Connector No.	B48
Connector Name	WIRE TO WIRE
Connector Color	WHITE



Terminal No.	Color of Wire	Signal Name
2	Y	-
3	SB	-
12	GR	-

ABLIA5774GB

INTERIOR ROOM LAMP

< WIRING DIAGRAM >

Connector No.	B108
Connector Name	FRONT DOOR SWITCH RH
Connector Color	WHITE

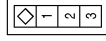

Terminal No.	Color of Wire	Signal Name
2	LG	-

Terminal No.	Color of Wire	Signal Name
32J	GR	-
33J	SB	-
37J	Y	-
40J	P	-
41J	GR	-

Connector No.	B69
Connector Name	WIRE TO WIRE
Connector Color	WHITE

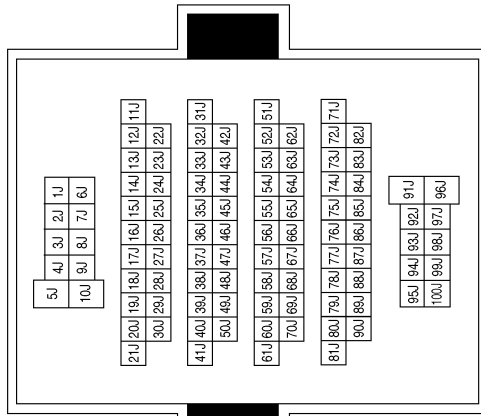

Connector No.	B116
Connector Name	REAR DOOR SWITCH RH
Connector Color	WHITE

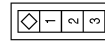

Terminal No.	Color of Wire	Signal Name
2	L	-

ABLIA5775GB

A
B
C
D
E
F
G
H
I
J
K
L
M
N
O
P

INL

INTERIOR ROOM LAMP

< WIRING DIAGRAM >

Connector No.	D14
Connector Name	FRONT DOOR LOCK ASSEMBLY LH
Connector Color	GRAY



Terminal No.	Color of Wire	Signal Name
3	R/W	-
4	B	-
5	SB	-

Connector No.	D7
Connector Name	MAIN POWER WINDOW AND DOOR LOCK/UNLOCK SWITCH
Connector Color	WHITE

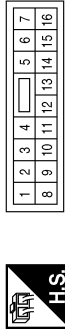

Terminal No.	Color of Wire	Signal Name
10	LG	-
11	W	-
14	B	-

Connector No.	D2
Connector Name	WIRE TO WIRE
Connector Color	BROWN

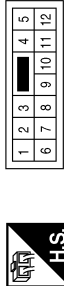

Terminal No.	Color of Wire	Signal Name
9	B	-

Connector No.	D105
Connector Name	POWER WINDOW AND DOOR LOCK/UNLOCK SWITCH RH
Connector Color	WHITE

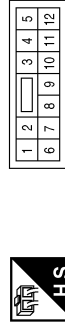

Terminal No.	Color of Wire	Signal Name
1	LG	-
2	W	-
3	B	-

Connector No.	D102
Connector Name	WIRE TO WIRE
Connector Color	WHITE

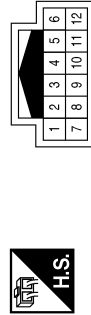

Terminal No.	Color of Wire	Signal Name
2	W	-
3	LG	-

Connector No.	D101
Connector Name	WIRE TO WIRE
Connector Color	WHITE



Terminal No.	Color of Wire	Signal Name
10	B	-

ABLIA6704GB

A
B
C
D
E
F
G
H
I
J
K
INL
M
N
O
P

INTERIOR ROOM LAMP

< WIRING DIAGRAM >

Connector No.	D152
Connector Name	WIRE TO WIRE
Connector Color	WHITE

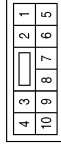

Terminal No.	Color of Wire	Signal Name
10	B	-

Connector No.	D151
Connector Name	WIRE TO WIRE
Connector Color	WHITE

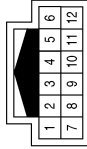

Terminal No.	Color of Wire	Signal Name
2	P	-
3	W	-

Connector No.	D150
Connector Name	WIRE TO WIRE
Connector Color	WHITE

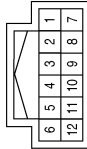

Terminal No.	Color of Wire	Signal Name
2	P	-
3	W	-

Connector No.	D405
Connector Name	WIRE TO WIRE
Connector Color	WHITE

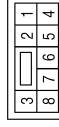

Terminal No.	Color of Wire	Signal Name
1	Y	-
2	SB	-
6	B	-
7	GR	-

Connector No.	D402
Connector Name	WIRE TO WIRE
Connector Color	WHITE

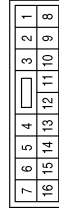

Terminal No.	Color of Wire	Signal Name
2	Y	-
3	SB	-
12	GR	-

Connector No.	D153
Connector Name	WIRE TO WIRE
Connector Color	WHITE



Terminal No.	Color of Wire	Signal Name
10	B	-

ABLIA6705GB

INTERIOR ROOM LAMP

< WIRING DIAGRAM >

Connector No.	D502
Connector Name	BACK DOOR SWITCH
Connector Color	WHITE

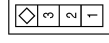

Terminal No.	Color of Wire	Signal Name
1	B	-
3	Y	-

Connector No.	D501
Connector Name	WIRE TO WIRE
Connector Color	WHITE

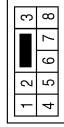

Terminal No.	Color of Wire	Signal Name
1	Y	-
2	SB	-
6	B	-
7	GR	-

Connector No.	D409
Connector Name	WIRE TO WIRE
Connector Color	WHITE



Terminal No.	Color of Wire	Signal Name
2	B	-

Connector No.	D650
Connector Name	WIRE TO WIRE
Connector Color	WHITE



Terminal No.	Color of Wire	Signal Name
2	B	-

Connector No.	D505
Connector Name	BACK DOOR KEY CYLINDER SWITCH
Connector Color	BROWN



Terminal No.	Color of Wire	Signal Name
1	SB	-
2	B	-
3	GR	-

ABLIA5779GB

A
B
C
D
E
F
G
H
I
J
K
L
M
N
O
P

INL

ILLUMINATION

< WIRING DIAGRAM >

ILLUMINATION

Wiring Diagram

INFOID:000000011068501

⬡ : WITH OFF-ROAD LAMPS

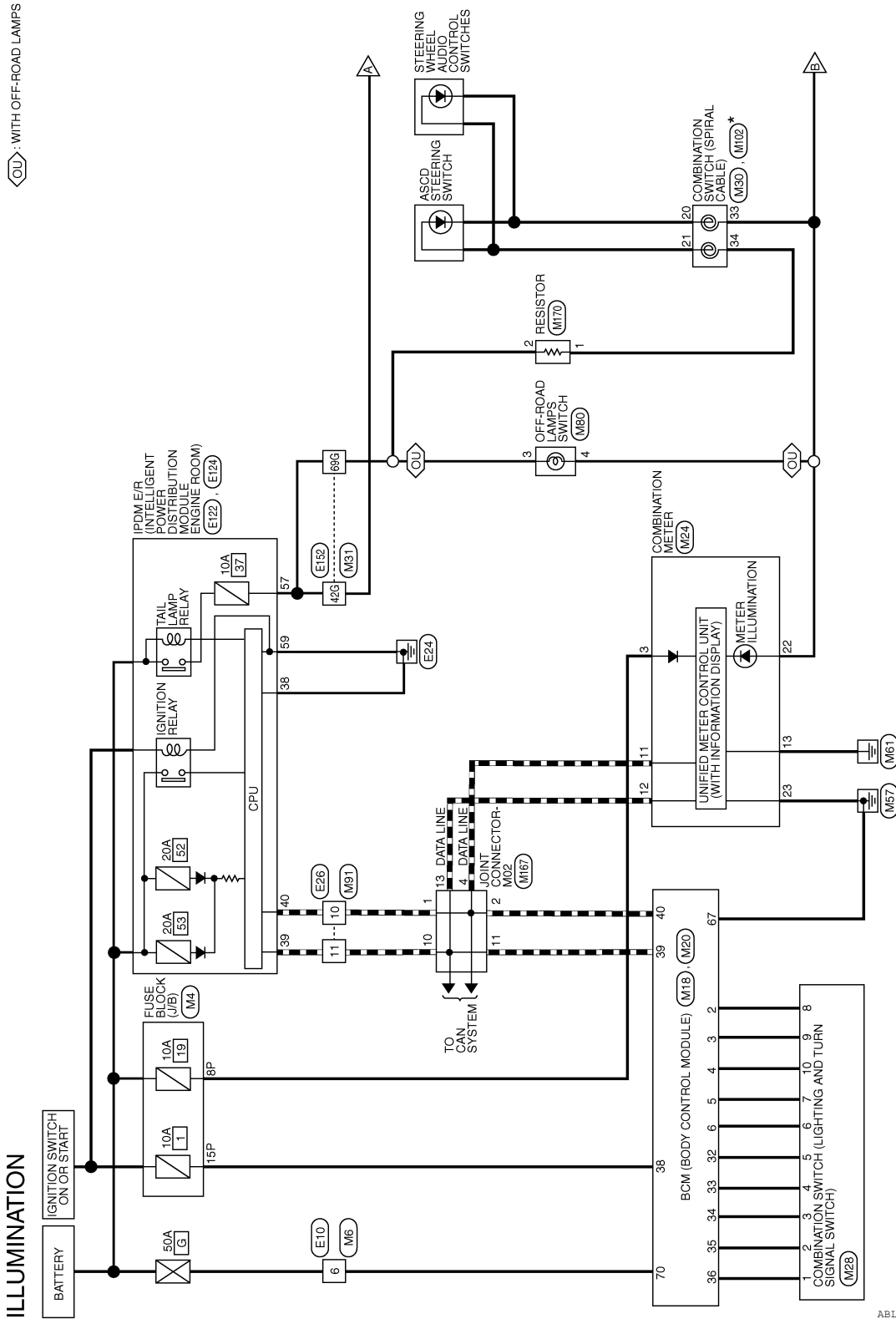

*: THIS CONNECTOR IS NOT SHOWN IN "HARNES LAYOUT" OF PG SECTION.

ABLWA2753GB

ILLUMINATION

< WIRING DIAGRAM >

- <4W> : WITH 4-WHEEL DRIVE
- <BA> : WITH BASE AUDIO SYSTEM
- <CI> : WITH CLUTCH INTERLOCK CANCEL SWITCH
- <DL> : WITH ELECTRONIC LOCKING REAR DIFFERENTIAL
- <EN> : WITHOUT NAVI
- <NQ> : WITH DISPLAY AUDIO SYSTEM
- <NV> : WITH NAVI
- <PM> : WITH POWER OUTSIDE MIRRORS

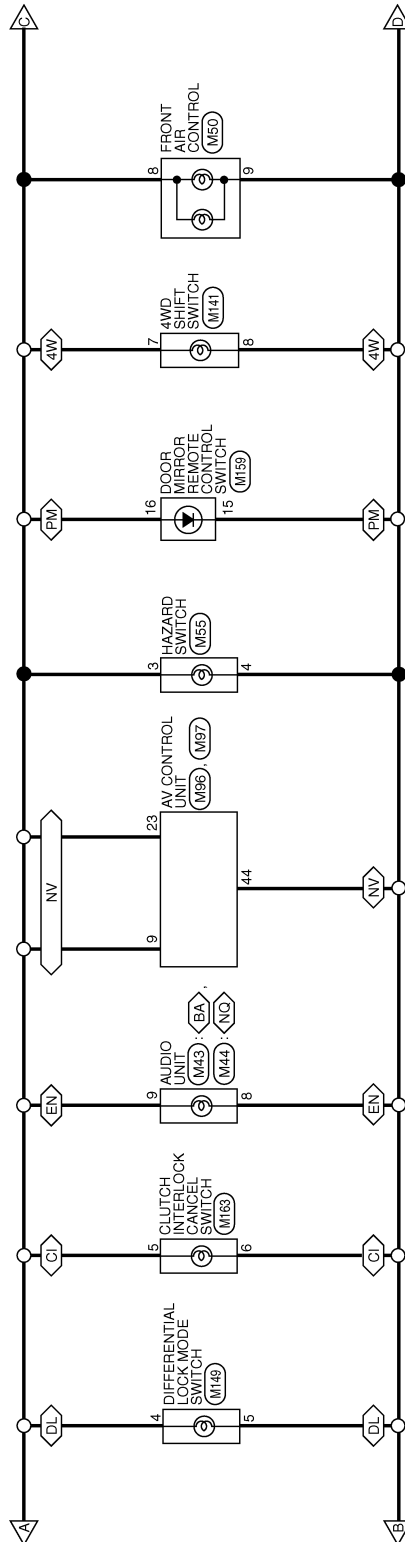

ABLWA2420GB

A
B
C
D
E
F
G
H
I
J
K
INL
M
N
O
P

ILLUMINATION

< WIRING DIAGRAM >

-  : WITH A/T
-  : WITH HILL DESCENT CONTROL AND HILL START ASSIST
-  : WITH HEATED SEATS

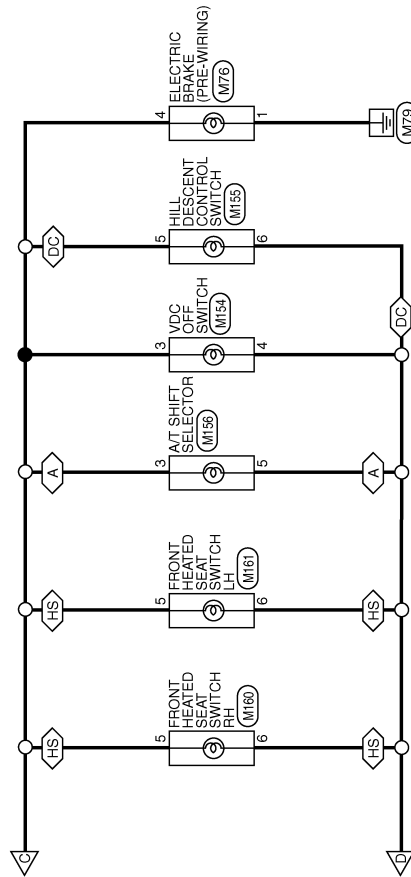

ABLWA2425GB

ILLUMINATION CONNECTORS

Connector No.	M4
Connector Name	FUSE BLOCK (J/B)
Connector Color	WHITE



Terminal No.	Color of Wire	Signal Name
8P	R/Y	-
15P	W/R	-

Connector No.	M6
Connector Name	WIRE TO WIRE
Connector Color	WHITE



Terminal No.	Color of Wire	Signal Name
6	W	-

Connector No.	M18
Connector Name	BCM (BODY CONTROL MODULE)
Connector Color	WHITE

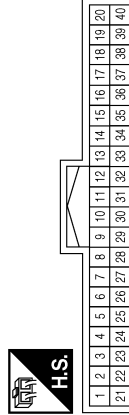

Terminal No.	Color of Wire	Signal Name
2	P	INPUT 5
3	SB	INPUT 4
4	V	INPUT 3
5	L	INPUT 2
6	R	INPUT 1
32	BG	OUTPUT 5
33	GR	OUTPUT 4
34	G	OUTPUT 3
35	BR	OUTPUT 2
36	LG	OUTPUT 1

Terminal No.	Color of Wire	Signal Name
38	W/R	IGN SW
39	L	CAN-H
40	P	CAN-L

Connector No.	M20
Connector Name	BCM (BODY CONTROL MODULE)
Connector Color	BLACK



Terminal No.	Color of Wire	Signal Name
67	B	GND (POWER)
70	W	BAT (F/L)

ABLIA6706GB

A
B
C
D
E
F
G
H
I
J
K
L
M
N
O
P

INL

ILLUMINATION

< WIRING DIAGRAM >

Terminal No.	Color of Wire	Signal Name
5	BG	-
6	R	-
7	L	-
8	P	-
9	SB	-
10	V	-

Connector No.	M28
Connector Name	COMBINATION SWITCH
Connector Color	WHITE

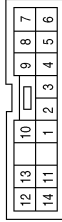

Terminal No.	Color of Wire	Signal Name
1	LG	-
2	BR	-
3	G	-
4	GR	-

Connector No.	M24
Connector Name	COMBINATION METER
Connector Color	WHITE

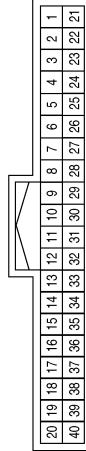

Terminal No.	Color of Wire	Signal Name
3	R/Y	BATTERY
11	P	CAN-L
12	L	CAN-H
13	GR	GROUND
22	BR	ILLUMINATION CONTROL
23	B	POWER GND

Terminal No.	Color of Wire	Signal Name
42G	R	-
69G	V	-

Connector No.	M31
Connector Name	WIREF TO WIRE
Connector Color	WHITE

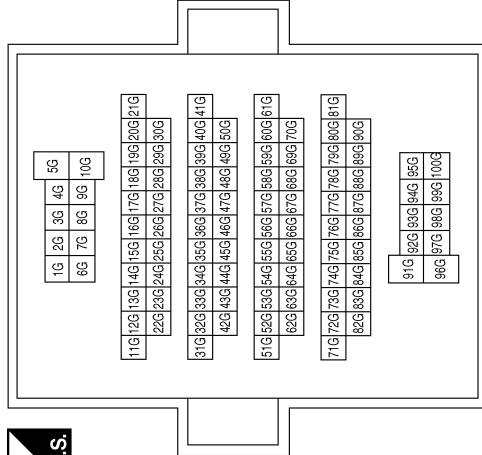

Connector No.	M30
Connector Name	COMBINATION SWITCH (SPIRAL CABLE)
Connector Color	GRAY

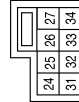

Terminal No.	Color of Wire	Signal Name
33	V	-
34	LG	-

ABLIA5786GB

ILLUMINATION

< WIRING DIAGRAM >

Connector No.	M50
Connector Name	FRONT AIR CONTROL
Connector Color	BLACK

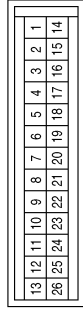

Terminal No.	Color of Wire	Signal Name
8	G	ILLUM+
9	BR	ILLUM-

Connector No.	M44
Connector Name	AUDIO UNIT (WITH DISPLAY AUDIO SYSTEM)
Connector Color	WHITE

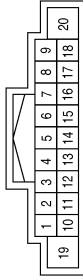

Terminal No.	Color of Wire	Signal Name
8	GR	ILL (-)
9	R	ILL (+)

Connector No.	M43
Connector Name	AUDIO UNIT (WITH BASE AUDIO SYSTEM)
Connector Color	WHITE

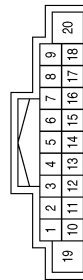

Terminal No.	Color of Wire	Signal Name
8	GR	ILL (-)
9	R	ILL (+)

Connector No.	M80
Connector Name	OFF-ROAD LAMPS SWITCH
Connector Color	GRAY

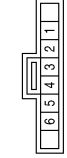

Terminal No.	Color of Wire	Signal Name
3	V	-
4	BR	-

Connector No.	M76
Connector Name	ELECTRIC BRAKE (PRE-WIRING)
Connector Color	WHITE



Terminal No.	Color of Wire	Signal Name
1	B	-
4	R	-

Connector No.	M55
Connector Name	HAZARD SWITCH
Connector Color	WHITE



Terminal No.	Color of Wire	Signal Name
3	R	-
4	BR	-

ABLIA5787GB

A
B
C
D
E
F
G
H
I
J
K
L
M
N
O
P

INL

ILLUMINATION

< WIRING DIAGRAM >

Connector No.	M97
Connector Name	AV CONTROL UNIT (WITH NAVI)
Connector Color	WHITE

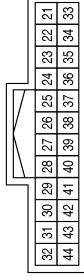

Terminal No.	Color of Wire	Signal Name
23	P	MR OUTPUT
44	GR	ILL CONT

Connector No.	M96
Connector Name	AV CONTROL UNIT (WITH NAVI)
Connector Color	WHITE

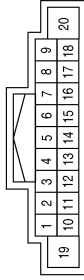

Terminal No.	Color of Wire	Signal Name
9	R	LIGHT SW

Connector No.	M91
Connector Name	WIRE TO WIRE
Connector Color	WHITE

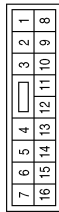

Terminal No.	Color of Wire	Signal Name
10	P	-
11	L	-

Connector No.	M149
Connector Name	DIFFERENTIAL LOCK MODE SWITCH
Connector Color	WHITE



Terminal No.	Color of Wire	Signal Name
4	R	-
5	BR	-

Connector No.	M141
Connector Name	4WD SHIFT SWITCH
Connector Color	GRAY

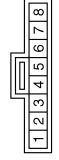

Terminal No.	Color of Wire	Signal Name
7	R	-
8	BR	-

Connector No.	M102
Connector Name	COMBINATION SWITCH (SPIRAL CABLE)
Connector Color	GRAY



Terminal No.	Color of Wire	Signal Name
20	W	-
21	R	-

ABLIA5788GB

ILLUMINATION

< WIRING DIAGRAM >

Connector No.	M156
Connector Name	A/T SHIFT SELECTOR
Connector Color	WHITE

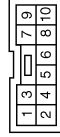

Terminal No.	Color of Wire	Signal Name
3	R	-
5	BR	-

Connector No.	M155
Connector Name	HILL DESCENT CONTROL SWITCH
Connector Color	WHITE

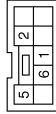

Terminal No.	Color of Wire	Signal Name
5	R	-
6	BR	-

Connector No.	M154
Connector Name	VDC OFF SWITCH
Connector Color	GRAY

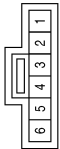

Terminal No.	Color of Wire	Signal Name
3	R	-
4	BR	-

Connector No.	M161
Connector Name	FRONT HEATED SEAT SWITCH LH
Connector Color	WHITE



Terminal No.	Color of Wire	Signal Name
5	R	-
6	BR	-

Connector No.	M160
Connector Name	FRONT HEATED SEAT SWITCH RH
Connector Color	BROWN



Terminal No.	Color of Wire	Signal Name
5	SB	-
6	BG	-

Connector No.	M159
Connector Name	DOOR MIRROR REMOTE CONTROL SWITCH
Connector Color	WHITE

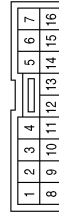

Terminal No.	Color of Wire	Signal Name
15	BR	-
16	R	-

ABLIA5789GB

A
B
C
D
E
F
G
H
I
J
K
INL
M
N
O
P

ILLUMINATION

< WIRING DIAGRAM >

Connector No.	M170
Connector Name	RESISTOR
Connector Color	BLACK



Terminal No.	Color of Wire	Signal Name
1	LG	-
2	R	-

Connector No.	M167
Connector Name	JOINT CONNECTOR-M02
Connector Color	BLUE

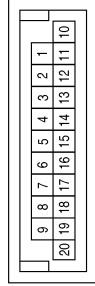

Terminal No.	Color of Wire	Signal Name
1	P	-
2	P	-
4	P	-
10	L	-
11	L	-
13	L	-

Connector No.	M163
Connector Name	CLUTCH INTERLOCK CANCEL SWITCH
Connector Color	WHITE

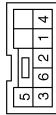

Terminal No.	Color of Wire	Signal Name
5	R	-
6	BR	-

Connector No.	E122
Connector Name	IPDM E/R (INTELLIGENT POWER DISTRIBUTION MODULE ENGINE ROOM)
Connector Color	WHITE

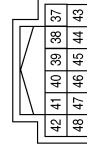

Terminal No.	Color of Wire	Signal Name
38	B	GND (SIGNAL)
39	L	CAN-H
40	P	CAN-L

Connector No.	E26
Connector Name	WIRE TO WIRE
Connector Color	WHITE



Terminal No.	Color of Wire	Signal Name
10	P	-
11	L	-

Connector No.	E10
Connector Name	WIRE TO WIRE
Connector Color	WHITE



Terminal No.	Color of Wire	Signal Name
6	W	-

ABLIA5790GB

ILLUMINATION

< WIRING DIAGRAM >

Terminal No.	Color of Wire	Signal Name
42G	R	-
69G	V	-

Connector No.	E152
Connector Name	WIRE TO WIRE
Connector Color	WHITE

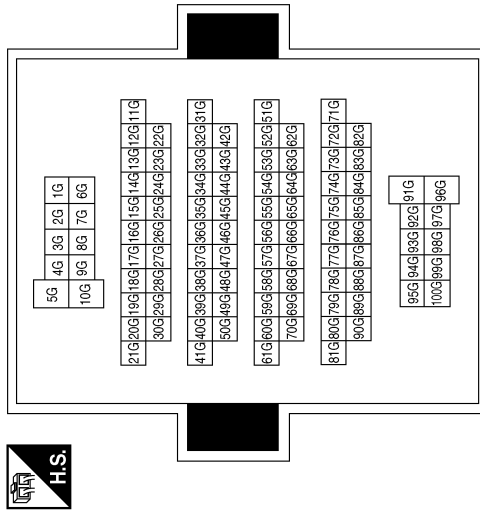

Connector No.	E124
Connector Name	IPDM E/R (INTELLIGENT POWER DISTRIBUTION MODULE ENGINE ROOM)
Connector Color	BLACK



Terminal No.	Color of Wire	Signal Name
57	GR	TAIL LAMP
59	B	GND (POWER)

A
B
C
D
E
F
G
H
I
J
K
L
M
N
O
P

INL

ABLIA5791GB

INTERIOR LIGHTING SYSTEM SYMPTOMS

< SYMPTOM DIAGNOSIS >

SYMPTOM DIAGNOSIS

INTERIOR LIGHTING SYSTEM SYMPTOMS

Symptom Table

INFOID:000000011068502

CAUTION:

Perform the self-diagnosis with CONSULT before the symptom diagnosis. Perform the trouble diagnosis if any DTC is detected.

Symptom	Possible cause	Inspection item
All of the following lamps do not turn ON <ul style="list-style-type: none"> • Front room/map lamp assembly • Room lamp 2nd row • Cargo room lamp • Ignition keyhole illumination 	<ul style="list-style-type: none"> • Harness between BCM and each interior room lamp • Harness between BCM and each door switch • BCM 	Battery saver output/power supply circuit Refer to INL-16 .
Some or all of the following interior room lamps do not turn ON/OFF <ul style="list-style-type: none"> • Front room/map lamp assembly • Room lamp 2nd row 	<ul style="list-style-type: none"> • Harness between BCM and each door switch • Harness between BCM and each interior room lamp • BCM 	Door switch circuit Refer to DLK-24 . Interior room lamp control circuit Refer to INL-18 .
Cargo lamp does not turn ON/OFF	<ul style="list-style-type: none"> • Harness between BCM and cargo lamp • BCM 	Cargo lamp circuit Refer to INL-20 .
Ignition keyhole illumination (if equipped) does not turn ON/OFF	<ul style="list-style-type: none"> • Harness between BCM and ignition keyhole illumination • BCM 	Ignition keyhole illumination circuit Refer to INL-22
Interior room lamp timer does not activate. (It turns ON/ OFF when the door opens/closes.)	—	Check the interior room lamp setting. Refer to BCS-17 , "INT LAMP : CONSULT Function (BCM - INT LAMP)".
Interior room lamp battery saver does not activate.	—	Check the interior room lamp battery saver setting. Refer to BCS-23 , "BATTERY SAVER : CONSULT Function (BCM - BATTERY SAVER)".

PRECAUTIONS

< PRECAUTION >

PRECAUTION

PRECAUTIONS

Precaution for Supplemental Restraint System (SRS) "AIR BAG" and "SEAT BELT PRE-TENSIONER"

INFOID:000000011068503

The Supplemental Restraint System such as "AIR BAG" and "SEAT BELT PRE-TENSIONER", used along with a front seat belt, helps to reduce the risk or severity of injury to the driver and front passenger for certain types of collision. This system includes seat belt switch inputs and dual stage front air bag modules. The SRS system uses the seat belt switches to determine the front air bag deployment, and may only deploy one front air bag, depending on the severity of a collision and whether the front occupants are belted or unbelted. Information necessary to service the system safely is included in the SR and SB section of this Service Manual.

WARNING:

- To avoid rendering the SRS inoperative, which could increase the risk of personal injury or death in the event of a collision which would result in air bag inflation, all maintenance must be performed by an authorized NISSAN/INFINITI dealer.
- Improper maintenance, including incorrect removal and installation of the SRS, can lead to personal injury caused by unintentional activation of the system. For removal of Spiral Cable and Air Bag Module, see the SR section.
- Do not use electrical test equipment on any circuit related to the SRS unless instructed to in this Service Manual. SRS wiring harnesses can be identified by yellow and/or orange harnesses or harness connectors.

PRECAUTIONS WHEN USING POWER TOOLS (AIR OR ELECTRIC) AND HAMMERS

WARNING:

- When working near the Airbag Diagnosis Sensor Unit or other Airbag System sensors with the Ignition ON or engine running, DO NOT use air or electric power tools or strike near the sensor(s) with a hammer. Heavy vibration could activate the sensor(s) and deploy the air bag(s), possibly causing serious injury.
- When using air or electric power tools or hammers, always switch the Ignition OFF, disconnect the battery and wait at least three minutes before performing any service.

Precaution for Work

INFOID:000000011068504

- When removing or disassembling each component, be careful not to damage or deform it. If a component may be subject to interference, be sure to protect it with a shop cloth.
- When removing (disengaging) components with a screwdriver or similar tool, be sure to wrap the component with a shop cloth or vinyl tape to protect it.
- Protect the removed parts with a shop cloth and prevent them from being dropped.
- Replace a deformed or damaged clip.
- If a part is specified as a non-reusable part, always replace it with a new one.
- Be sure to tighten bolts and nuts securely to the specified torque.
- After installation is complete, be sure to check that each part works properly.
- Follow the steps below to clean components:
 - Water soluble dirt:
 - Dip a soft cloth into lukewarm water, wring the water out of the cloth and wipe the dirty area.
 - Then rub with a soft, dry cloth.
 - Oily dirt:
 - Dip a soft cloth into lukewarm water with mild detergent (concentration: within 2 to 3%) and wipe the dirty area.
 - Then dip a cloth into fresh water, wring the water out of the cloth and wipe the detergent off.
 - Then rub with a soft, dry cloth.
 - Do not use organic solvent such as thinner, benzene, alcohol or gasoline.
 - For genuine leather seats, use a genuine leather seat cleaner.

PREPARATION

< PREPARATION >

PREPARATION

PREPARATION

Special Service Tool

INFOID:000000011068505

The actual shape of the tools may differ from those illustrated here.

Tool number (TechMate No.) Tool name	Description
— (J-46534) Trim Tool Set	Removing trim components

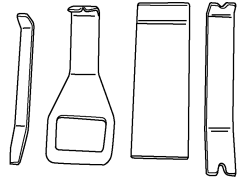

AWJIA0483ZZ

INTERIOR ROOM LAMP

< REMOVAL AND INSTALLATION >

REMOVAL AND INSTALLATION

INTERIOR ROOM LAMP

Removal and Installation

INFOID:000000011068506

FRONT ROOM/MAP LAMP ASSEMBLY

Removal

1. Using a suitable tool, release the metal clips and drop the front room/map lamp assembly away from the headlining.
↳: Front
☐: Metal clip
2. Disconnect the harness connectors from the front room/map lamp assembly and remove.

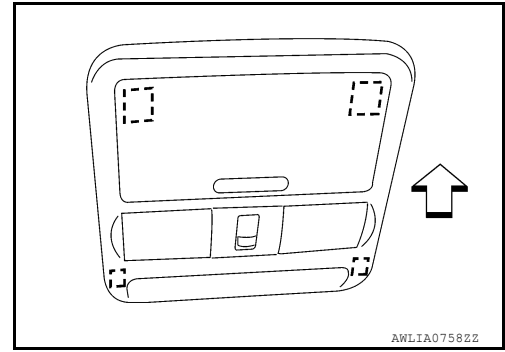

Installation

Installation is in the reverse order of removal.

Bulb Replacement

1. Using a suitable tool (A), remove front room/map lamp assembly lens (1).
↳: Front
○: Pawl
2. Release one side of the bulb (2) from the tab, then pull straight downward to remove.
3. Install the bulb (2).
4. Install front room/map lamp lens (1).

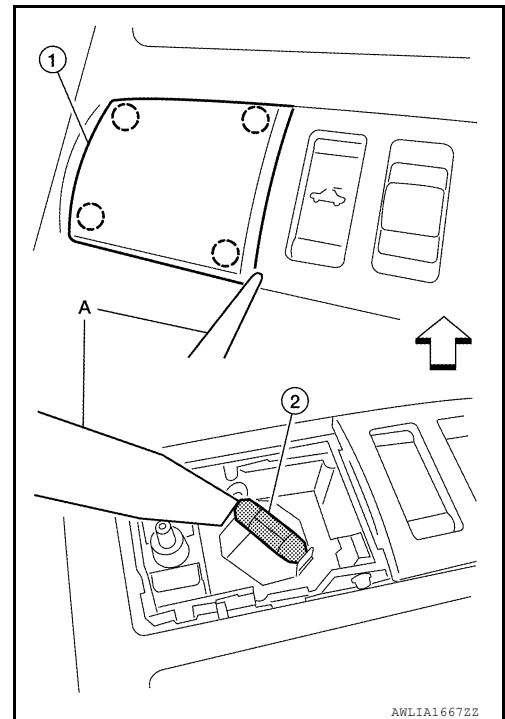

ROOM LAMP 2ND ROW

Removal

A
B
C
D
E
F
G
H
I
J
K
INL
M
N
O
P

INTERIOR ROOM LAMP

< REMOVAL AND INSTALLATION >

1. Using a suitable tool (A), release the pawls and remove the room lamp 2nd row lens (1).
○: Pawl
2. Remove room lamp 2nd row screws (2).
3. Disconnect the harness connector from the room lamp 2nd row and remove.

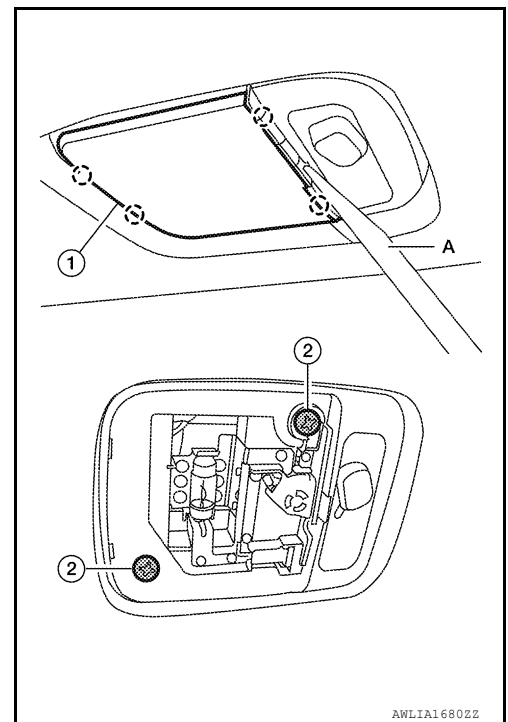

Installation

Installation is in the reverse order of removal.

Bulb Replacement

1. Using a suitable tool, release the pawls and remove the room lamp 2nd row lens.
2. Release the room lamp 2nd row bulb retainers (1), then pull bulb (2) straight out to remove.
3. Install the bulb (2).
4. Install the room lamp 2nd row lens.

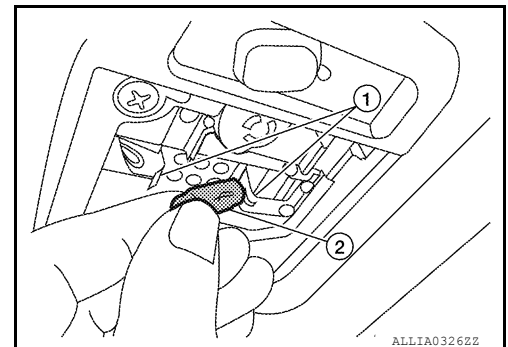

CARGO LAMP

Removal

INTERIOR ROOM LAMP

< REMOVAL AND INSTALLATION >

1. Using a suitable tool (A), release the pawls and remove the cargo lamp lens (1).
2. Remove cargo lamp screws (2).
3. Disconnect the harness connector from the cargo lamp and remove.

○: Pawl

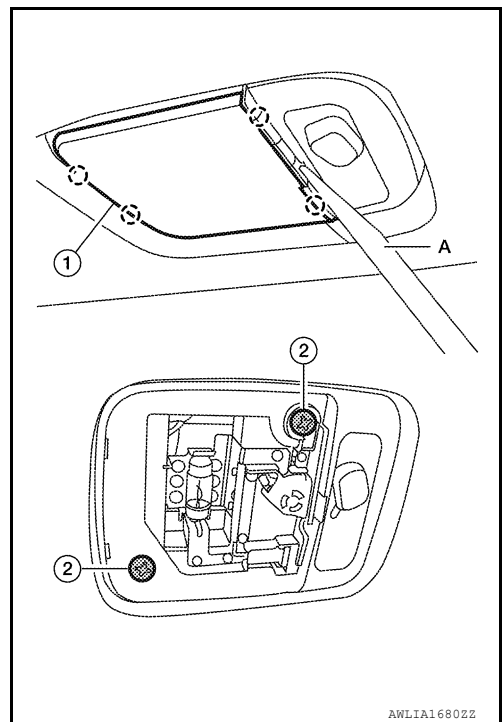

Installation

Installation is in the reverse order of removal.

Bulb Replacement

1. Using a suitable tool, release the pawls and remove the cargo lamp lens.
2. Release the cargo lamp bulb retainers (1), then pull bulb (2) straight out to remove.
3. Install the bulb (2).
4. Install the cargo lamp lens.

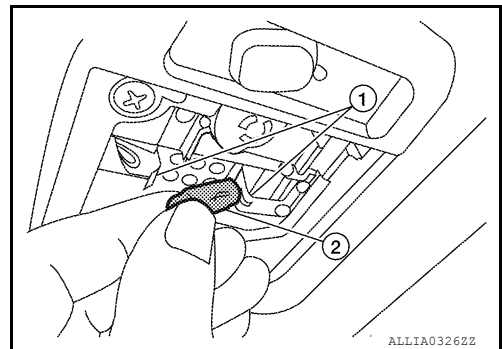

A
B
C
D
E
F
G
H
I
J
K
INL
M
N
O
P

ILLUMINATION

< REMOVAL AND INSTALLATION >

ILLUMINATION

Removal and Installation

INFOID:000000011068507

ILLUMINATION CONTROL SWITCH

Removal

The illumination control switch is replaced as a part of the combination meter. Refer to [MWI-84, "Removal and Installation"](#).

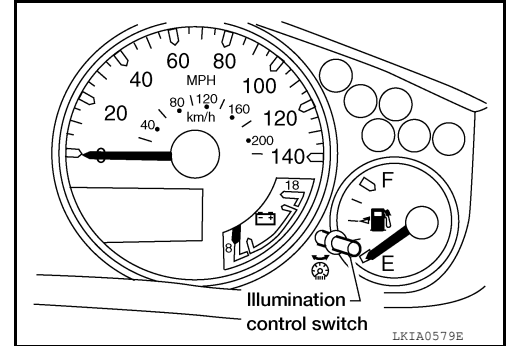

Installation

Installation is in the reverse order of removal.

SHIFT SELECTOR FINISHER LAMP

Removal

1. Remove shift selector finisher from center console. Refer to [IP-20, "Removal and Installation"](#).
2. Rotate shift selector finisher lamp socket (2) with bulb (3) counterclockwise, then pull away from shift selector (1).

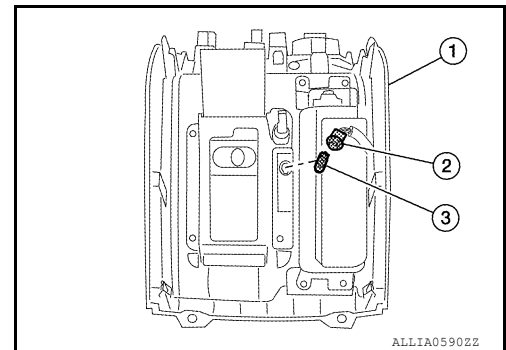

Installation

Installation is in the reverse order of removal.

Bulb Replacement

1. Remove shift selector finisher from center console. Refer to [IP-20, "Removal and Installation"](#).
2. Remove shift selector finisher lamp socket (1), then pull bulb (2) straight out away from socket.
3. Install the bulb (2) to the shift selector finisher lamp socket (1).
4. Install shift selector to center console. Refer to [IP-20, "Removal and Installation"](#).

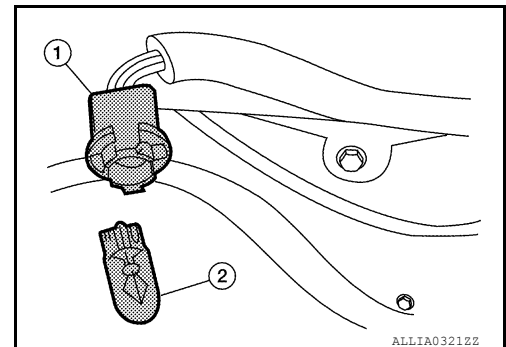

IGNITION KEYHOLE ILLUMINATION LAMP

Removal

1. Partially remove LH front door welt and position aside. Refer to [INT-18, "Removal and Installation"](#).
2. Remove front pillar lower finisher. Refer to [INT-18, "Removal and Installation"](#).
3. Remove instrument lower panel LH. Refer to [IP-14, "Removal and Installation"](#).

ILLUMINATION

< REMOVAL AND INSTALLATION >

4. Partially remove the BCM and position aside.
5. Remove ignition keyhole illumination lamp.

Installation

Installation is in the reverse order of removal.

Bulb Replacement

1. Remove keyhole illumination lamp.
2. Pull bulb (2) straight out from keyhole illumination lamp socket (1) to remove.
3. Install the bulb (2) to keyhole illumination lamp socket (1).
4. Install keyhole illumination lamp.

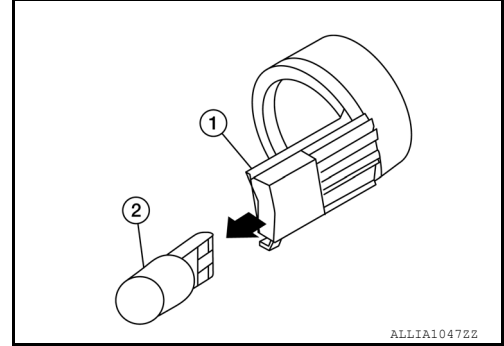

A
B
C
D
E
F
G
H
I
J
K
L
M
N
O
P

INL

BULB SPECIFICATIONS

< SERVICE DATA AND SPECIFICATIONS (SDS)

SERVICE DATA AND SPECIFICATIONS (SDS)

BULB SPECIFICATIONS

Bulb Specifications

INFOID:0000000011068508

Item	Wattage (W)*
Front room/map lamp	8
Room lamp 2nd row	8
Cargo lamp	8
Shift selector finisher lamp	2.3
Ignition Keyhole Illumination	-

*: Always check with the Parts Department for the latest parts information.